



HSK TOOLING SYSTEM

BIG DAISHOWA SEIKI CO LTD

CATALOG No. **EXi181-3**

TOOLING SYSTEM



In Accordance To ISO12164 & DIN69893
HSK-A40,50,63,100 E25,32,40,50 F63



INDEX



Clamping Range:
ø.018" - ø.238"

Ultra slim design eliminates any interference.
MEGA MICRO CHUCK®

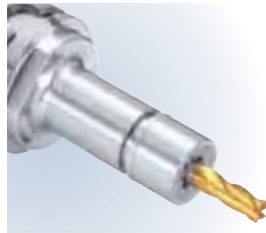

Clamping Range:
ø.010" - ø.787"

Most reliable high precision collet chuck in the world.
MEGA NEW BABY CHUCK®



Clamping Range:
ø1/8" - ø1/2"

World's first! BIG original designed holder for small dia. end milling.
MEGA E CHUCK®

A Type

40 50 63 PG. 6-7

40 50 63 100 PG. 9-11

40 50 63 100 PG. 14-15

E Type

25 32 40 50 PG. 25-26

25 32 40 50 PG. 27

F Type

63 PG. 29

63 PG. 29

63 PG. 30

ACCESSORIES

MEGA WRENCH PG. 6
MEGA NUT PG. 6
MEGA MICRO COLLET PG. 8
COOLANT PIPE PG. 17

MEGA WRENCH PG. 10
ADJUSTING SCREW PG. 10
MEGA NUT PG. 10
COLLET EJECTOR PG. 11
NEW BABY COLLET PG. 12
MEGA PERFECT SEAL PG. 13
COOLANT PIPE PG. 17

MEGA E COLLET PG. 15
MEGA WRENCH PG. 14
ADJUSTING SCREW PG. 14
MEGA E NUT PG. 14
COOLANT PIPE PG. 17



Clamping Range:
ø5/8" - ø1-1/4"

Specialist for heavy-duty cutting.
MEGA DOUBLE POWER CHUCK®



Original & No. 1 modular boring system in the world.
KAB TOOL SHANKS



Tapping Range:
No.2 - AU3/4

Unique feature to compensate for synchronization errors.
MEGA SYNCHRO Tapping Holder **NEW**



Cutter Dia:
ø.630" - ø1.969"

Indexable insert end mill offering both accuracy and toughness.
FULLCUT MILL
Type FCM / FCR

63 100 PG. 16

63 100 PG. 17

40 50 63 100 PG. 18

40 50 63 PG. 21, 23

40 50 PG. 28

25 32 40 PG. 28

63 PG. 30

MEGA WRENCH PG. 16
PSC COLLET PG. 16
(High Precision Type)
STRAIGHT COLLET PG. 16
(Type "C")
COOLANT PIPE PG. 17

COOLANT PIPE PG. 17

TAP HOLDER PG. 19
MGT SET SCREW PG. 20
SYNCHRO ADJUSTER PG. 20
O RING SET PG. 20
MGT NUT PG. 20
MEGA WRENCH PG. 20
COOLANT PIPE PG. 17

(FCM)
INDEXABLE INSERTS PG. 22
SPARE PARTS PG. 22
(FCR)
INDEXABLE INSERTS PG. 24
SPARE PARTS PG. 24
COOLANT PIPE PG. 17

High Quality HSK Tooling by **BIG** BIG DAISHOWA

1 Premium Material Selection

Since HSK is a hollow taper shank, the material has a critical role for optimum performance. BIG uses carefully selected high grade alloy steels. Particularly, BIG uses die steel materials for HSK 40 and smaller where the cross section of shank taper is very thin.

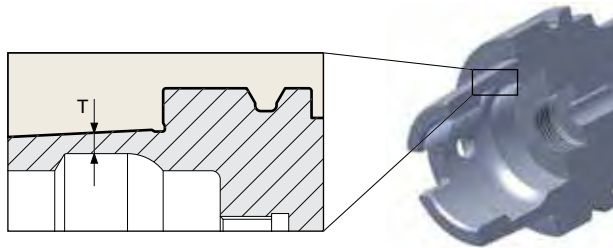

HSK Size	25	32	40	50	63	100
T	.043	.049	.076	.102	.137	.204

2 Important Tool Retention Feature

Internal clamping of HSK tools is defined by the location of highly concentrated forces from the machine tool. Accuracy and position of this form will affect the rigidity, repeatability, and precision of the tool holders. BIG provides finish machining of this area after heat treatment.

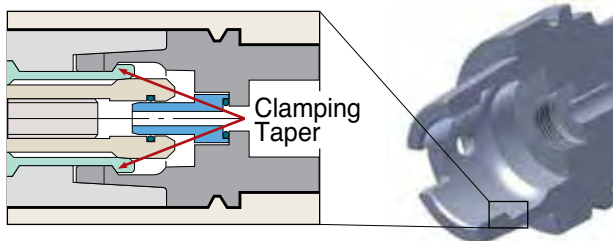

3 Drive Key Form

HSK shanks according to Form A are designed to carry out torque transmission by the round shaped key-way at the end of the taper. Because of the importance of this round shaped geometry, BIG provides finishing of this feature after heat treatment.

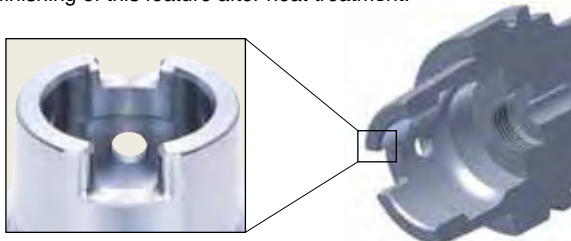

4 Pre-Balanced Design

Since HSK Form A has non-symmetric keyways, it is not balanced. BIG Form A holders are pre-balanced near the tool change V-Groove recommended by ISO standard and can therefore be used for high speed applications.

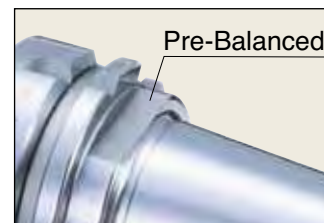

5 With Hole for Manual Clamping

BIG HSK Form A holders have a manual clamping hole as a standard and can therefore be used in place of HSK Form C which is manually mounted in spindles.

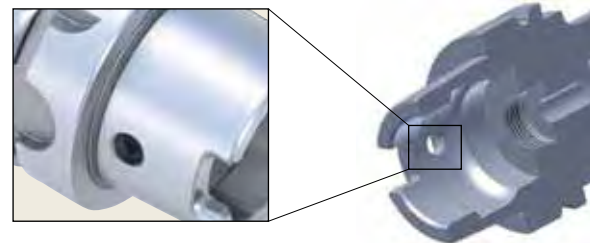

6 With IC-Data Chip Holes

A hole (Dia.10mm) is provided on the flange for an IC data chip. Tool management can be carried out by using this ID chip in order to minimize downtime, and to improve current capacity utilization.

(Note: IC chips are not included as a standard item)



IC Data Chip

High precision, high rigidity & high quality performance

MEGA CHUCK[®] SERIES

Clamping Range: ϕ .010" - ϕ 1-1/4"



Four types of Mega Chuck series holders optimize high speed and precise cutting with drills and end mills. Depending on the application, the ideal chuck can be selected to enhance cutting performance.

For micro drills & end mills

MEGA MICRO CHUCK[®]

Clamping Range: ϕ .018" - ϕ .238"



Form A PG. 6

Form E PG. 25

Form F PG. 29

"Taper Type" For Micro End Milling

The super slim taper type of the Mega Micro Chuck makes it suitable for micro end mills.



MEGA MICRO COLLET

Interval of clamping dia. is .004". Just fitting for micro cutting tools.

Collet Class	T.I.R.		.00004" .00012"
	At nose	At end of test bar	
AA	.00004"	.00012"	

For end mills, drills, taps, reamers, etc.

MEGA NEW BABY CHUCK[®]

Clamping Range: ϕ .010" - ϕ .787"

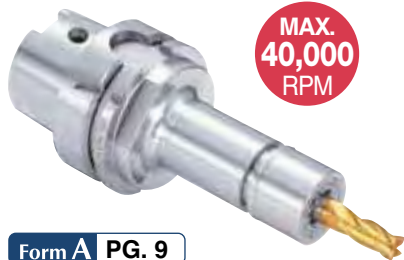

Guaranteed Accuracy of .00004" T.I.R. at the Collet Nose

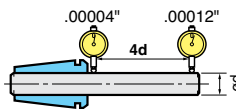

NEW BABY COLLET

Collet Class	T.I.R.	
	At nose	At end of test bar
AA	.00004"	.00012"

Form A PG. 9

Form E PG. 27

Form F PG. 29

For High Pressure Coolant Supply

Nut with seal for Mega New Baby Chuck. Performance of the seal improves with higher coolant pressure.

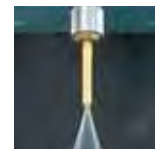
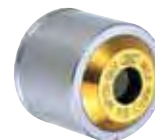

Through Tools

Jet Through

MEGA PERFECT SEAL PAT.
US Patent No. 5975817

MAX. COOLANT PRESSURE
1,000 PSI

ORIGINAL DESIGN OF NOTCH-FREE NUT PREVENTS VIBRATION AND NOISE

Vibration at high speeds is eliminated by a notch-free nut which offers superior balance and concentricity. This ideal nut design not only eliminates whistling noise and coolant splattering, but also assures increased strength of the nut itself.

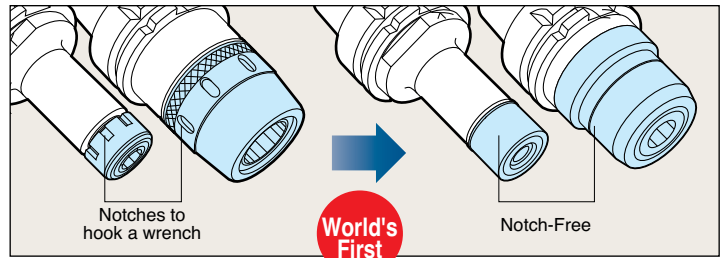

EASY AND FIRM CLAMPING WITH THE MEGA WRENCH

The Mega Wrench has a uniquely designed one-way clutch system with a roller bearing and ratchet function and is capable of safely and evenly applying force on the entire nut periphery.

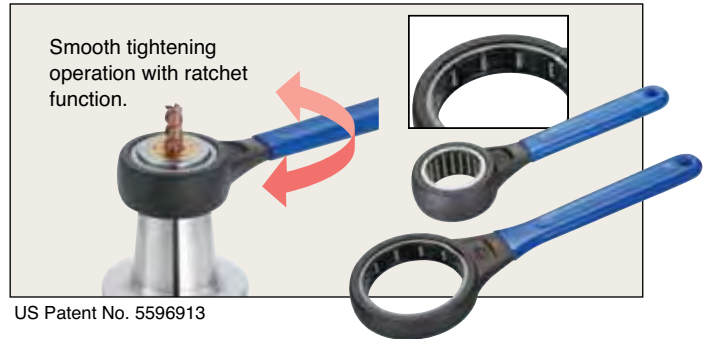

For end mills MEGA E CHUCK®

Clamping Range: $\varnothing 1/8''$ - $\varnothing 1/2''$



Form A PG. 14

Form F PG. 30

Slit-Through Coolant

Coolant is securely directed to the cutting tool through slits in the collet, even at high spindle speeds. Tool life and surface finish is improved as a result of efficient chip evacuation. Rubber seals are provided within the nut and body in order to prevent coolant leakage.



High Clamping Force

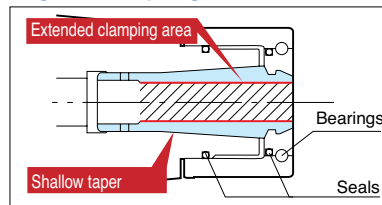

Collet Class	T.I.R.	
	At nose	At end of test bar
AA	.00004"	.00012"

.00004" .00012"

4d

\varnothing

For end mills MEGA DOUBLE POWER CHUCK®

Clamping Range: $\varnothing 5/8''$ - $\varnothing 1-1/4''$



Form A PG. 16

Complete Fit of Nut and Body Achieves High Rigidity as an Integral Body.

In the case of a conventional milling chuck, the inner taper of the nut contacts only with the body when tightened. However, there is still a gap between the nut and body. Large fit diameter of the nut provides higher rigidity as if the chuck and nut were an integral body. This superior rigidity assures heavy cutting without chatter.

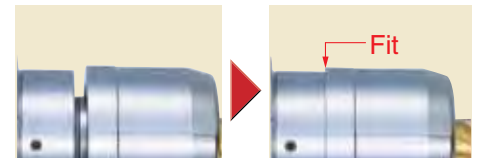

Effective Coolant Supply

- For improved surface finish
- Extended tool life
- Smoother chip evacuation
- Cooling & lubricating of tools

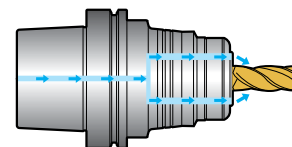

Coolant-Through Nozzles



Tool holder for rigid tapping

License **EMUGE**

NEW

MEGA SYNCHRO Tapping Holder

Tapping Range: No.2 - AU3/4



Comparison of Surface Finish

● Spiral Tap (No.10 - 24 Material: 4130)



Collet Chuck

BIG MEGA SYNCHRO

Form A PG. 18

Wide Variation of Bodies and Tap Holders

Unique feature to compensate for synchronization errors.

Improves thread quality and tool life by reducing thrust loads caused by synchronization errors up to 90%.

For Mega Synchro Tapping Holder, please refer to catalog

No. 163

Indexable Insert End Mill

FULLCUT MILL FCM / FCR

Cutter Dia: ϕ .630" - ϕ 1.969"

Type **FCM**

Square shoulder & slot milling cutter



Form A PG. 21

Form E PG. 28

For Fullcut Mill Type FCM, please refer to catalog

No. 134

Type **FCR**

Ramping & helical milling cutter



Form A PG. 23

For Fullcut Mill Type FCR, please refer to catalog

No. 135

Indexable insert end mills with both excellent sharpness and toughness, achieving the performance of solid end mills.

Sharp cutting edge by both high radial and axial rake angles

Positive high rake cutting edge for both radial and axial directions achieves smooth and quiet end milling.

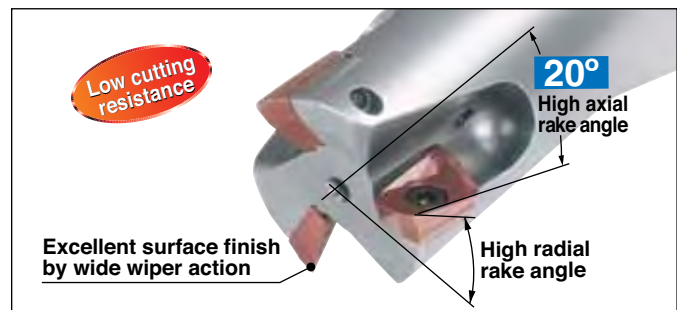

Micro diameter design is ideal for high speed applications in tight areas with small diameter cutting tools.



**MAX.
35,000
RPM**

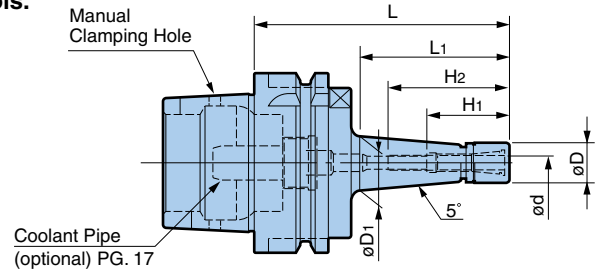

Type T Form A (DIN 69893-1) (ISO 12164)

Model	$\varnothing d$	$\varnothing D$	$\varnothing D1$	L	L1	H1	H2	Max. RPM	Collet	Weight (lbs)
HSK-A40-MEGA3S-75T	.018 - .128	.394	.571	2.95	1.57	.87	1.50	32,000	NBC3S-□	.62
-90T			.681	3.54	2.20			28,000		.68
-MEGA4S-60T	.018 - .159	.472	.547	2.36	1.02	1.04	1.73	35,000	NBC4S-□	.59
-75T			.657	2.95	1.65			32,000		.66
-90T			.760	3.54	2.28			28,000		.73
-105T			.870	4.13	2.87			25,000		.81
-MEGA6S-60T ※			.018 - .238	.551	.614			2.36		1.06
-75T	.724	2.95			1.69	32,000	.68			
-90T	.831	3.54			2.32	28,000	.75			
-105T	.941	4.13			2.91	25,000	.86			
HSK-A50-MEGA3S-105T	.018 - .128	.394	.744	4.13	2.56	.87	1.50	28,000	NBC3S-□	1.21
-MEGA4S-105T	.018 - .159	.472	.811	4.13	2.56	1.04	1.85	25,000	NBC4S-□	1.28
-MEGA6S-105T	.018 - .238	.551	.874	4.13	2.56	1.12	1.93	25,000	NBC6S-□	1.32
HSK-A63-MEGA3S-75T	.018 - .128	.394	.535	2.95	1.38	.87	1.50	32,000	NBC3S-□	1.76
-90T			.638	3.54	1.97			28,000		1.83
-120T			.846	4.72	3.15			25,000		1.98
-MEGA4S-60T	.018 - .159	.472	.512	2.36	.91	1.04	1.46	35,000	NBC4S-□	1.76
-75T			.606	2.95	1.38			32,000		1.81
-90T			.709	3.54	1.97			28,000		1.87
-105T			.811	4.13	2.56			25,000		1.98
-120T			.917	4.72	3.15			22,000		2.05
-135T			1.020	5.31	3.74			20,000		2.20
-MEGA6S-60T	.018 - .238	.551	.606	2.36	.91	1.12	1.46	35,000	NBC6S-□	1.76
-75T			.669	2.95	1.38			32,000		1.83
-90T			.772	3.54	1.97			28,000		1.89
-105T			.874	4.13	2.56			25,000		1.98
-120T			.976	4.72	3.15			22,000		2.09
-135T			1.083	5.31	3.74			20,000		2.20

1. Nut is included. Collet and wrench must be ordered separately.

2. Coolant pipe must be ordered separately.



3. For models marked ※, there is no internal thread.

The dimension H₂ in () shows how deep a tool can be inserted.

4. Maximum operating speeds are directly influenced by the rigidity of the machine.

Therefore, when determining the optimum cutting conditions, increase the cutting parameters gradually.

5. Weight does not include collet.

Accessories			Spare Parts	
	Mega Wrench 	Collet  PG. 8	Mega Nut 	
Mega Micro Chuck	Model	Model	Model	
MEGA3S	MGR10	NBC3S-□	MGN3S	
MEGA4S	MGR12	NBC4S-□	MGN4S	
MEGA6S	MGR14	NBC6S-□	MGN6S	



**MAX.
30,000
RPM**

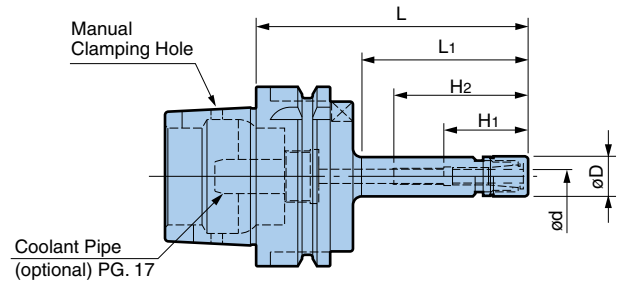

Type S Form A (DIN 69893-1) (ISO 12164)

Model	ød	øD	L	L1	H1	H2	Max. RPM	Collet	Weight (lbs)
HSK-A40-MEGA3S-60	.018 - .128	.394	2.36	.98	.87	1.54	30,000	NBC3S-□	.57
-MEGA4S-60	.018 - .159	.472	2.36	.98	1.04	1.73	30,000	NBC4S-□	.57
-90			3.54			2.17			
-MEGA6S-60 ※	.018 - .238	.551	2.36	1.02	1.12	(1.57)	30,000	NBC6S-□	.59
-90			3.54			2.20			
HSK-A50-MEGA3S-75	.018 - .128	.394	2.95	1.38	.87	1.50	30,000	NBC3S-□	1.08
-MEGA4S-75	.018 - .159	.472	2.95	1.38	1.04	1.85	30,000	NBC4S-□	1.10
-MEGA6S-75	.018 - .238	.551	2.95	1.38	1.12	1.93	30,000	NBC6S-□	1.12
HSK-A63-MEGA3S-60	.018 - .128	.394	2.36	.87	.87	1.38	30,000	NBC3S-□	1.76
-MEGA4S-75	.018 - .159	.472	2.95	1.38	1.04	1.89	30,000	NBC4S-□	1.76
-105			4.13			2.36			
-MEGA6S-75	.018 - .238	.551	2.95	1.38	1.12	1.89	30,000	NBC6S-□	1.81
-105			4.13			2.36			

1. Nut is included. Collet and wrench must be ordered separately.
2. Coolant pipe must be ordered separately.
3. For models marked ※, there is no internal thread.
The dimension H2 in () shows how deep a tool can be inserted.
4. Maximum operating speeds are directly influenced by the rigidity of the machine.
Therefore, when determining the optimum cutting conditions, increase the cutting parameters gradually.
5. Weight does not include collet.

For ACCESSORIES and SPARE PARTS PG. 6

Clamping Range: ø.018" - ø.238"

STRAIGHT SHANK TYPE

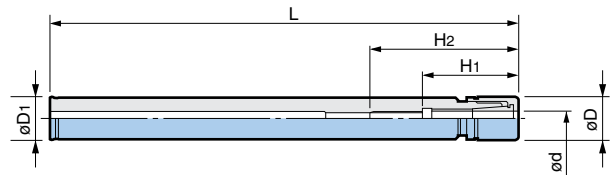
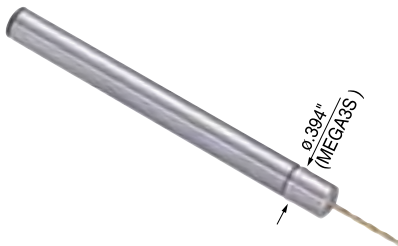

Model	ød	øD	øD1	L	H1	H2	Collet	Weight (lbs)
ST.375-MEGA3S-120	.018 - .128	.394	.375	4.724	.87	1.50	NBC3S-□	.13
ST.500-MEGA4S-130	.018 - .159	.472	.500	5.118	1.04	1.85	NBC4S-□	.24
-160				6.299				
ST.625-MEGA6S-160	.018 - .238	.551	.625	6.299	1.12	1.93	NBC6S-□	.40
-200				7.874				

1. MGNS Nut is included. Collet and wrench must be ordered separately.
2. Weight does not include collet.

For ACCESSORIES and SPARE PARTS PG. 6

MEGA MICRO COLLET



Ultra Small High Precision Collet

Concentricity is better than .00004" at the collet nose. This high precision is achieved by the innovative design of combining taper and straight body contact.

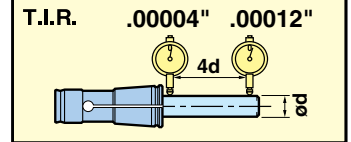
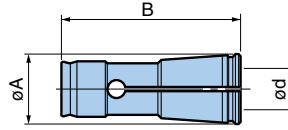

MEGA3S	
Model	Clamping Range $\varnothing d$
NBC3S-0.5AA	.018 - .022
-0.6AA	.022 - .026
-0.7AA	.026 - .030
-0.8AA	.030 - .033
-0.9AA	.033 - .037
-1.0AA	.037 - .041
-1.1AA	.041 - .045
-1.2AA	.045 - .049
-1.3AA	.049 - .053
-1.4AA	.053 - .057
-1.5AA	.057 - .061
-1.6AA	.061 - .065
-1.7AA	.065 - .069
-1.8AA	.069 - .073
-1.9AA	.073 - .077
-2.0AA	.077 - .081
-2.1AA	.081 - .085
-2.2AA	.085 - .089
-2.3AA	.089 - .093
-2.4AA	.093 - .096
-2.5AA	.096 - .100
-2.6AA	.100 - .104
-2.7AA	.104 - .108
-2.8AA	.108 - .112
-2.9AA	.112 - .116
-3.0AA	.116 - .120
-3.1AA	.120 - .124
-3.175AA	.123 - .127
-3.2AA	.124 - .128

$\varnothing A = .239$ $B = .740$

MEGA4S	
Model	Clamping Range $\varnothing d$
NBC4S-0.5AA	.018 - .022
-0.6AA	.022 - .026
-0.7AA	.026 - .030
-0.8AA	.030 - .033
-0.9AA	.033 - .037
-1.0AA	.037 - .041
-1.1AA	.041 - .045
-1.2AA	.045 - .049
-1.3AA	.049 - .053
-1.4AA	.053 - .057
-1.5AA	.057 - .061
-1.6AA	.061 - .065
-1.7AA	.065 - .069
-1.8AA	.069 - .073
-1.9AA	.073 - .077
-2.0AA	.077 - .081
-2.1AA	.081 - .085
-2.2AA	.085 - .089
-2.3AA	.089 - .093
-2.4AA	.093 - .096
-2.5AA	.096 - .100
-2.6AA	.100 - .104
-2.7AA	.104 - .108
-2.8AA	.108 - .112
-2.9AA	.112 - .116
-3.0AA	.116 - .120
-3.1AA	.120 - .124
-3.175AA	.123 - .127
-3.2AA	.124 - .128
-3.3AA	.128 - .132
-3.4AA	.132 - .136
-3.5AA	.136 - .140
-3.6AA	.140 - .144
-3.7AA	.144 - .148
-3.8AA	.148 - .152
-3.9AA	.152 - .156
-4.0AA	.156 - .159

$\varnothing A = .291$ $B = .886$

MEGA6S			
Model	Clamping Range $\varnothing d$	Model	Clamping Range $\varnothing d$
NBC6S-0.5AA	.018 - .022	NBC6S-4.1AA	.159 - .163
-0.6AA	.022 - .026	-4.2AA	.163 - .167
-0.7AA	.026 - .030	-4.3AA	.167 - .171
-0.8AA	.030 - .033	-4.4AA	.171 - .175
-0.9AA	.033 - .037	-4.5AA	.175 - .179
-1.0AA	.037 - .041	-4.6AA	.179 - .183
-1.1AA	.041 - .045	-4.7AA	.183 - .187
-1.2AA	.045 - .049	-4.7625AA	.186 - .189
-1.3AA	.049 - .053	-4.8AA	.187 - .191
-1.4AA	.053 - .057	-4.9AA	.191 - .195
-1.5AA	.057 - .061	-5.0AA	.195 - .199
-1.6AA	.061 - .065	-5.1AA	.199 - .203
-1.7AA	.065 - .069	-5.2AA	.203 - .207
-1.8AA	.069 - .073	-5.3AA	.207 - .211
-1.9AA	.073 - .077	-5.4AA	.211 - .215
-2.0AA	.077 - .081	-5.5AA	.215 - .219
-2.1AA	.081 - .085	-5.6AA	.219 - .222
-2.2AA	.085 - .089	-5.7AA	.222 - .226
-2.3AA	.089 - .093	-5.8AA	.226 - .230
-2.4AA	.093 - .096	-5.9AA	.230 - .234
-2.5AA	.096 - .100	-6.0AA	.234 - .238
-2.6AA	.100 - .104		
-2.7AA	.104 - .108		
-2.8AA	.108 - .112		
-2.9AA	.112 - .116		
-3.0AA	.116 - .120		
-3.1AA	.120 - .124		
-3.175AA	.123 - .127		
-3.2AA	.124 - .128		
-3.3AA	.128 - .132		
-3.4AA	.132 - .136		
-3.5AA	.136 - .140		
-3.6AA	.140 - .144		
-3.7AA	.144 - .148		
-3.8AA	.148 - .152		
-3.9AA	.152 - .156		
-4.0AA	.156 - .159		

$\varnothing A = .370$ $B = .965$

Form A MEGA NEW BABY CHUCK® for high speed

The body, collet, nut and wrench are specifically designed to be ideal for high speed operations.



**MAX.
35,000
RPM**

Coolant-through hole

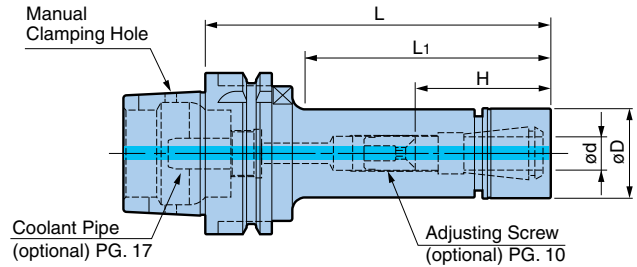

Form A (DIN 69893-1) (ISO 12164)

Model	ød	øD	L	L1	H	Max. RPM	Collet	Weight (lbs)	
HSK-A40-MEGA6N-60 ✱	.010 - .236	.787	2.36	1.18	1.30	35,000	NBC6-□	.68	
-75			2.95	1.77	.91 - 1.50	30,000		.75	
-90			3.54	2.36	.91 - 1.69			.81	
-MEGA8N-60 ✱	.020 - .315	.984	2.36	1.18	1.61	35,000	NBC8-□	.77	
-75			2.95	1.77	1.02 - 1.50	30,000		.86	
-90			3.54	2.36	1.02 - 1.73			.97	
-MEGA10N-60 ✱	.059 - .394	1.181	2.36	1.02	1.57	35,000	NBC10-□	.93	
-75 ✱			2.95	1.54	2.17	30,000		1.08	
-90			3.54	2.13	1.50 - 1.89			1.23	
-MEGA13N-75 ✱	.098 - .512	1.378	2.95	2.17	2.17	25,000	NBC13-□	1.21	
-90 ✱			3.54	2.76	2.52			1.41	
-MEGA16N-75 ✱	.098 - .630	1.654	2.95	2.17	2.09	20,000	NBC16-□	1.43	
-90 ✱			3.54	2.76	2.48	15,000		1.72	
-MEGA20N-90 ✱	.098 - .787	1.811	3.54	2.76	2.60	15,000	NBC20-□	1.89	
HSK-A50-MEGA6N-60 ✱	.010 - .236	.787	2.36	1.02	1.38	35,000	NBC6-□	1.10	
-75			2.95	1.34	.91 - 1.69	30,000		1.32	
-100			3.94	2.32		25,000		1.32	
-120			4.72	3.11		23,000		1.54	
-135			5.31	3.70		20,000		1.54	
-165			6.50	4.80		15,000		1.76	
-MEGA8N-60 ✱	.020 - .315	.984	2.36	1.02		1.34	35,000	NBC8-□	1.10
-75			2.95	1.46	1.02 - 1.46	30,000	1.32		
-100			3.94	2.32	1.02 - 1.77	28,000	1.54		
-120			4.72	3.11		25,000	1.76		
-135			5.31	3.70		20,000	1.76		
-165			6.50	4.88		15,000	1.98		
-MEGA10N-60 ✱	.059 - .394	1.181	2.36	1.02		1.38	35,000	NBC10-□	1.32
-75 ✱			2.95	1.42		1.81	33,000		1.54
-100			3.94	2.40	1.50 - 1.89	25,000	1.76		
-120			4.72	3.19		20,000	1.98		
-135			5.31	3.78		15,000	2.20		
-165			6.50	4.96		10,000	2.42		
-MEGA13N-65 ✱	.098 - .512	1.378	2.56	1.17		1.54	30,000	NBC13-□	1.54
-75 ✱			2.95	1.50		1.81	28,000		1.54
-100			3.94	2.48	1.73 - 2.20	25,000	1.98		
-120			4.72	3.27	1.73 - 2.87	20,000	2.20		
-135			5.31	3.86		18,000	2.42		
-165			6.50	5.04		15,000	3.08		
-MEGA16N-75 ✱	.098 - .630	1.654	2.95	1.93		1.89	28,000	NBC16-□	2.20
-100			3.94	2.83	1.89 - 2.17	20,000	2.42		
-120			4.72	3.62	1.89 - 2.68	15,000	2.86		
-135			5.31	4.29		10,000	3.08		
-165			6.50	5.39		10,000	3.74		
-MEGA20N-75 ✱			.098 - .787	1.811		2.95	1.93		2.72
-100	3.94	2.91			2.01 - 2.68	15,000	2.86		
-120	4.72	3.70				13,000	3.52		
-135	5.31	4.29				10,000	3.96		
-165	6.50	5.47				8,000	4.85		







- Nut is included. Adjusting screw, collet and wrench must be ordered separately.
- Coolant pipe must be ordered separately.
- Maximum operating speeds are directly influenced by the rigidity of the machine. Therefore, when determining the optimum cutting conditions, increase the cutting parameters gradually.
- Adjusting screws cannot be used with models marked ✱.
H "max" is the maximum tool shank length that can be inserted into the holder.
- Weight does not include collet.

For ACCESSORIES and SPARE PARTS PG. 10

Model	$\varnothing d$	$\varnothing D$	L	L ₁	H	Max. RPM	Collet	Weight (lbs)
HSK-A63-MEGA6N-75	.010 - .236	.787	2.95	1.38	.91 - 1.50	35,000	NBC6-□	1.98
-90			3.54	2.01	.91 - 1.69	30,000		1.98
-105			4.13	2.60		1.98		
-120			4.72	3.19		2.20		
-135			5.31	3.78		2.20		
-165			6.50	4.96	15,000	2.20		
-MEGA8N-75	.020 - .315	.984	2.95	1.50	1.02 - 1.50	35,000	NBC8-□	1.98
-90			3.54	2.01	1.02 - 1.77	30,000		2.20
-105			4.13	2.60		2.20		
-120			4.72	3.19		2.42		
-135			5.31	3.78		2.42		
-165			6.50	4.96	15,000	2.64		
-MEGA10N-75 ※	.059 - .394	1.181	2.95	1.50	1.97	33,000	NBC10-□	2.20
-90			3.54	2.01	1.50 - 1.77			2.20
-105			4.13	2.60	1.50 - 1.89	25,000		2.42
-120			4.72	3.19		2.64		
-135			5.31	3.78		2.86		
-165			6.50	0.47		15,000		3.08
-MEGA13N-75 ※	.098 - .512	1.378	2.95	1.54	1.93	30,000	NBC13-□	2.20
-90 ※			3.54	2.01	2.52			2.42
-105			4.13	2.60	1.73 - 2.20	25,000		2.64
-120			4.72	3.19	1.73 - 2.48	20,000		2.86
-135			5.31	3.78		3.08		
-165			6.50	4.96		15,000		3.74
-MEGA16N-75 ※	.098 - .630	1.654	2.95	1.54		1.89	30,000	NBC16-□
-90 ※			3.54	2.09	2.48	25,000		
-105			4.13	2.68	1.89 - 2.13	20,000	3.08	
-120			4.72	3.27	1.89 - 2.68	15,000	3.30	
-135			5.31	3.86		3.74		
-165			6.50	5.04		10,000	4.41	
-200	7.87	6.42	8,000	5.29				
-MEGA20N-75 ※	.098 - .787	1.811	2.95	1.54	2.01	30,000	NBC20-□	2.64
-90 ※			3.54	2.09	2.40			25,000
-105			4.13	2.68	2.01 - 2.13	20,000		3.30
-120			4.72	3.27	2.01 - 2.68	15,000		3.74
-135			5.31	3.86		3.96		
-165			6.50	5.04		10,000		5.07
-200	7.87	6.42	8,000	5.95				

- Nut is included. Adjusting screw, collet and wrench must be ordered separately.
- Coolant pipe must be ordered separately.
- Adjusting screws cannot be used with models marked ※. H "max" is the maximum tool shank length that can be inserted into the holder.

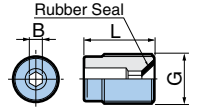
- Maximum operating speeds are directly influenced by the rigidity of the machine. Therefore, when determining the optimum cutting conditions, increase the cutting parameters gradually.
- Weight does not include collet.

Accessories								Spare Parts	
	Mega Wrench 	Collet  PG. 12	Sealing Nut Mega Perfect Seal  PG. 13	Adjusting Screw 	Rubber Seal 			Mega Nut 	
Mega New Baby Chuck	Model	Model	Model	Model	G	L	B(mm)	Model	
MEGA6N	MGR20	NBC6-□	MPS6-□	NBA6B	M7	.47	2	MGN6	
MEGA8N	MGR25	NBC8-□	MPS8-□	NBA8B	M9	.51	2.5	MGN8	
MEGA10N	MGR30	NBC10-□	MPS10-□	NBA10B	M11	.63	3	MGN10	
MEGA13N	MGR35	NBC13-□	MPS13-□	NBA13B	M14	.79	4	MGN13	
MEGA16N	MGR42	NBC16-□	MPS16-□	NBA16B	M18	.79	4	MGN16	
MEGA20N	MGR46	NBC20-□	MPS20-□	NBA20B	M21	.79	4	MGN20	

- For HSK Form E and F, Mega Perfect Seal cannot be used.



**MAX.
20,000
RPM**

(HSK-A100)

Coolant-through hole

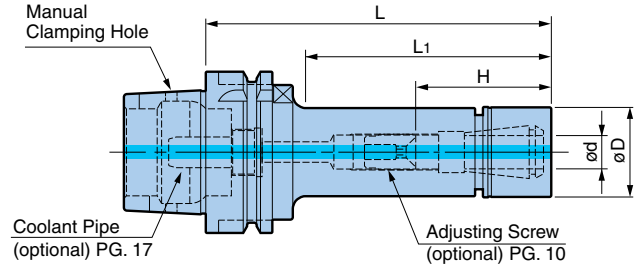

Form A (DIN 69893-1) (ISO 12164)

Model	ød	øD	L	L1	H	Max. RPM	Collet	Weight (lbs)
HSK-A100-MEGA6N-90	.010 - .236	.787	3.54	1.89	.91 - 1.69	20,000	NBC6-□	5.51
-105			4.13	2.48		18,000		5.51
-120			4.72	3.07		14,000		5.51
-135			5.31	3.66		12,000		5.73
-165			6.50	4.84		20,000		5.51
-MEGA8N-90	.020 - .315	.984	3.54	1.89	1.02 - 1.77	20,000	NBC8-□	5.51
-105			4.13	2.48		18,000		5.73
-120			4.72	3.07		14,000		5.73
-135			5.31	3.66		20,000		5.95
-165			6.50	4.84		18,000		5.95
-MEGA10N-90	.059 - .394	1.181	3.54	1.89	1.50 - 1.77	20,000	NBC10-□	5.73
-105			4.13	2.48		18,000		5.95
-120			4.72	3.07		14,000		5.95
-135			5.31	3.66		20,000		6.17
-165			6.50	4.84		18,000		6.61
-MEGA13N-90 ※	.098 - .512	1.378	3.54	1.89	2.17	18,000	NBC13-□	5.95
-105※			4.13	2.48	2.76	16,000		6.17
-120			4.72	3.07	1.73 - 2.48	14,000		6.39
-135			5.31	3.66		6.61		
-165			6.50	4.84		7.05		
-200			7.87	6.22		10,000		7.71
-MEGA16N-90 ※	.098 - .630	1.654	3.54	1.89	2.17	15,000	NBC16-□	6.17
-105※			4.13	2.48	2.76	14,000		6.39
-120			4.72	3.07	1.89 - 2.68	13,000		6.83
-135			5.31	3.66		7.93		
-165			6.50	4.84		10,000		8.81
-200			7.87	6.22		15,000		6.39
-MEGA20N-90 ※	.098 - .787	1.811	3.54	1.89	2.17	15,000	NBC20-□	6.39
-105※			4.13	2.48	2.76	14,000		6.61
-120			4.72	3.07	2.01 - 2.68	13,000		7.05
-135			5.31	3.66		7.27		
-165			6.50	4.84		8.37		
-200			7.87	6.22		10,000		9.47

1. Nut is included. Adjusting screw, collet and wrench must be ordered separately.
2. Coolant pipe must be ordered separately.
3. Adjusting screws cannot be used with models marked ※. H "max" is the maximum tool shank length that can be inserted into the holder.

4. Maximum operating speeds are directly influenced by the rigidity of the machine. Therefore, when determining the optimum cutting conditions, increase the cutting parameters gradually.
5. Weight does not include collet.

COLLET EJECTOR

Collet Ejector can easily and quickly remove New Baby Collets from Mega Nuts.



Model	Nut	Collet
NBC6-CE	MGN6	NBC6
NBC8-CE	MGN8	NBC8
NBC10-CE	MGN10	NBC10
NBC13-CE	MGN13	NBC13

NEW BABY COLLET



(BIG) The New Baby Collet is world renowned for its unmatched accuracy and precision. It offers runout accuracy of .00004" T.I.R. at the collet nose.

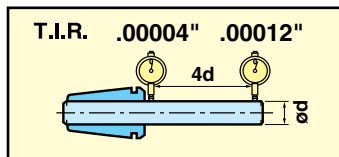
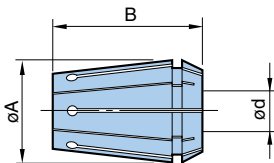

MEGA6N	
Model	Clamping Range $\varnothing d$
NBC6-0.5AA	.010 - .020
-0.75AA	.020 - .030
-1AA	.030 - .039
-1.25AA	.039 - .049
-1.5AA	.049 - .059
-1.75AA	.059 - .069
-2AA	.069 - .079
-2.25AA	.079 - .089
-2.5AA	.089 - .098
-2.75AA	.098 - .108
-3AA	.108 - .118
-3.175AA	.115 - .125
-3.25AA	.118 - .128
-3.5AA	.128 - .138
-3.75AA	.138 - .148
-4AA	.148 - .157
-4.25AA	.157 - .167
-4.5AA	.167 - .177
-4.75AA	.177 - .187
-5AA	.187 - .197
-5.25AA	.197 - .207
-5.5AA	.207 - .217
-5.75AA	.217 - .226
-6AA	.226 - .236

MEGA8N	
Model	Clamping Range $\varnothing d$
NBC8-0.75AA	.020 - .030
-1AA	.030 - .039
-1.25AA	.039 - .049
-1.5AA	.049 - .059
-1.75AA	.059 - .069
-2AA	.069 - .079
-2.25AA	.079 - .089
-2.5AA	.089 - .098
-2.75AA	.098 - .108
-3AA	.108 - .118
-3.175AA	.115 - .125
-3.5AA	.118 - .138
-4AA	.138 - .157
-4.5AA	.157 - .177
-5AA	.177 - .197
-5.5AA	.197 - .217
-6AA	.217 - .236
-6.5AA	.236 - .256
-7AA	.256 - .276
-7.5AA	.276 - .295
-8AA	.295 - .315

MEGA10N	
Model	Clamping Range $\varnothing d$
NBC10-1.75AA	.059 - .069
-2AA	.069 - .079
-2.25AA	.079 - .089
-2.5AA	.089 - .098
-2.75AA	.098 - .108
-3AA	.108 - .118
-3.175AA	.115 - .125
-3.5AA	.118 - .138
-4AA	.138 - .157
-4.5AA	.157 - .177
-5AA	.177 - .197
-5.5AA	.197 - .217
-6AA	.217 - .236
-6.5AA	.236 - .256
-7AA	.256 - .276
-7.5AA	.276 - .295
-8AA	.295 - .315
-8.5AA	.315 - .335
-9AA	.335 - .354
-9.5AA	.354 - .374
-10AA	.374 - .394

$\varnothing A = .492$ $B = .709$

$\varnothing A = .650$ $B = 1.063$

$\varnothing A = .374$ $B = .551$

MEGA13N	
Model	Clamping Range $\varnothing d$
NBC13-3AA	.098 - .118
-3.175AA	.115 - .125
-3.5AA	.118 - .138
-4AA	.138 - .157
-4.5AA	.157 - .177
-5AA	.177 - .197
-5.5AA	.197 - .217
-6AA	.217 - .236
-6.5AA	.236 - .256
-7AA	.256 - .276
-7.5AA	.276 - .295
-8AA	.295 - .315
-8.5AA	.315 - .335
-9AA	.335 - .354
-9.5AA	.354 - .375
-10AA	.376 - .394
-10.5AA	.394 - .413
-11AA	.413 - .433
-11.5AA	.433 - .453
-12AA	.453 - .472
-12.5AA	.472 - .492
-13AA	.492 - .512

MEGA16N	
Model	Clamping Range $\varnothing d$
NBC16-3AA	.098 - .118
-3.5AA	.118 - .138
-4AA	.138 - .157
-4.5AA	.157 - .177
-5AA	.177 - .197
-5.5AA	.197 - .217
-6AA	.217 - .236
-6.5AA	.236 - .256
-7AA	.256 - .276
-7.5AA	.276 - .295
-8AA	.295 - .315
-8.5AA	.315 - .335
-9AA	.335 - .354
-9.5AA	.354 - .375
-10AA	.376 - .394
-10.5AA	.394 - .413
-11AA	.413 - .433
-11.5AA	.433 - .453
-12AA	.453 - .472
-12.5AA	.472 - .492
-13AA	.492 - .512
-13.5AA	.512 - .531
-14AA	.531 - .551
-14.5AA	.551 - .571
-15AA	.571 - .591
-15.5AA	.591 - .610
-16AA	.610 - .630

$\varnothing A = 1.004$ $B = 1.378$

$\varnothing A = .807$ $B = 1.220$

MEGA20N	
Model	Clamping Range $\varnothing d$
NBC20-3AA	.098 - .118
-3.5AA	.118 - .138
-4AA	.138 - .157
-4.5AA	.157 - .177
-5AA	.177 - .197
-5.5AA	.197 - .217
-6AA	.217 - .236
-6.5AA	.236 - .256
-7AA	.256 - .276
-7.5AA	.276 - .295
-8AA	.295 - .315
-8.5AA	.315 - .335
-9AA	.335 - .354
-9.5AA	.354 - .375
-10AA	.376 - .394
-10.5AA	.394 - .413
-11AA	.413 - .433
-11.5AA	.433 - .453
-12AA	.453 - .472
-12.5AA	.472 - .492
-13AA	.492 - .512
-13.5AA	.512 - .531
-14AA	.531 - .551
-14.5AA	.551 - .571
-15AA	.571 - .591
-15.5AA	.591 - .610
-16AA	.610 - .630
-16.5AA	.630 - .650
-17AA	.650 - .669
-17.5AA	.669 - .689
-18AA	.689 - .709
-18.5AA	.709 - .728
-19AA	.728 - .750
-19.5AA	.751 - .768
-20AA	.768 - .787

$\varnothing A = 1.122$ $B = 1.496$

NEW BABY END MILL COLLET



For END MILL

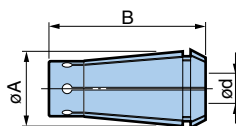

MEGA6N	
Model	$\varnothing d$
NBC6-1/8EAA	.125
-3/16EAA	.187

$\varnothing A = .362$ $B = .669$

MEGA8N	
Model	$\varnothing d$
NBC8-1/8EAA	.125
-3/16EAA	.187
-1/4 EAA	.250

$\varnothing A = .472$ $B = .787$

MEGA10N	
Model	$\varnothing d$
NBC10-1/8EAA	.125
-3/16EAA	.187
-1/4EAA	.250
-3/8EAA	.375

$\varnothing A = .630$ $B = 1.260$

MEGA13N	
Model	$\varnothing d$
NBC13-1/8EAA	.125
-3/16EAA	.187
-1/4EAA	.250
-3/8EAA	.375
-1/2EAA	.500

$\varnothing A = .787$ $B = 1.496$

MEGA16N	
Model	$\varnothing d$
NBC16-1/8EAA	.125
-3/16EAA	.187
-1/4EAA	.250
-3/8EAA	.375
-1/2EAA	.500
-5/8EAA	.625

$\varnothing A = .984$ $B = 1.654$

MEGA20N	
Model	$\varnothing d$
NBC20-1/8EAA	.125
-3/16EAA	.187
-1/4EAA	.250
-3/8EAA	.375
-1/2EAA	.500
-5/8EAA	.625
-3/4EAA	.750

$\varnothing A = 1.102$ $B = 1.772$

The tolerance of the cutting tool shank must be within h7.

MEGA PERFECT SEAL PAT. US Patent No. 5975817



MAX. COOLANT PRESSURE
1,000 PSI

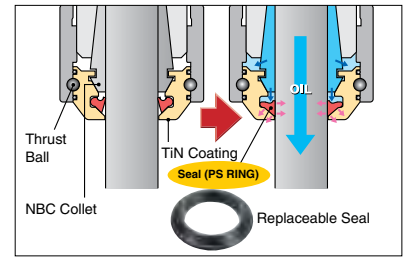
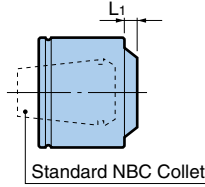

Reliable coolant supply to the tool tip!

Unique design increases sealing performance with higher coolant pressure to create a "perfect seal".

Remove the PS Ring to supply coolant to the cutting tool periphery.

2-Way Coolant

Through Tools

Jet Through



With PS Ring



Without PS Ring

Model	Cutter Shank Dia.	L1	Collet Model
MPS6-03035	.118 - .138	.091	NBC6-3-3.75
-0304	.118 - .157		-3-4.25
-04045	.157 - .177		-4-4.75
-0405	.157 - .197		-4-5.25
-05055	.197 - .217		-5-5.75
-0506	.197 - .236		-5-6
MPS8-03035	.118 - .138	.154	NBC8-3-4
-0304	.118 - .157		-3-4.5
-04045	.157 - .177		-4-5
-0405	.157 - .197		-4-5.5
-05055	.197 - .217		-5-6
-0506	.197 - .236		-5-6.5
MPS8-03035	.118 - .138	.134	NBC8-3-4
-0304	.118 - .157		-3-4.5
-04045	.157 - .177		-4-5
-0405	.157 - .197		-4-5.5
-05055	.197 - .217		-5-6
-0506	.197 - .236		-5-6.5
MPS10-03035	.118 - .138	.169	NBC10-3-4
-0304	.118 - .157		-3-4.5
-04045	.157 - .177		-4-5
-0405	.157 - .197		-4-5.5
-05055	.197 - .217		-5-6
-0506	.197 - .236		-5-6.5
MPS10-03035	.118 - .138	.138	NBC10-3-4
-0304	.118 - .157		-3-4.5
-04045	.157 - .177		-4-5
-0405	.157 - .197		-4-5.5
-05055	.197 - .217		-5-6
-0506	.197 - .236		-5-6.5
MPS13-03035	.118 - .138	.181	NBC13-3-4
-0304	.118 - .157		-3-4.5
-04045	.157 - .177		-4-5
-0405	.157 - .197		-4-5.5
-05055	.197 - .217		-5-6
-0506	.197 - .236		-5-6.5
MPS13-03035	.118 - .138	.169	NBC13-3-4
-0304	.118 - .157		-3-4.5
-04045	.157 - .177		-4-5
-0405	.157 - .197		-4-5.5
-05055	.197 - .217		-5-6
-0506	.197 - .236		-5-6.5
MPS13-03035	.118 - .138	.181	NBC13-3-4
-0304	.118 - .157		-3-4.5
-04045	.157 - .177		-4-5
-0405	.157 - .197		-4-5.5
-05055	.197 - .217		-5-6
-0506	.197 - .236		-5-6.5
MPS13-03035	.118 - .138	.193	NBC13-3-4
-0304	.118 - .157		-3-4.5
-04045	.157 - .177		-4-5
-0405	.157 - .197		-4-5.5
-05055	.197 - .217		-5-6
-0506	.197 - .236		-5-6.5
MPS13-03035	.118 - .138	.165	NBC13-3-4
-0304	.118 - .157		-3-4.5
-04045	.157 - .177		-4-5
-0405	.157 - .197		-4-5.5
-05055	.197 - .217		-5-6
-0506	.197 - .236		-5-6.5

Model	Cutter Shank Dia.	L1	Collet Model
MPS16-03035	.118 - .138	.157	NBC16-3-4
-0304	.118 - .157		-3-4.5
-04045	.157 - .177		-4-5
-0405	.157 - .197		-4-5.5
-05055	.197 - .217		-5-6
-0506	.197 - .236		-5-6.5
MPS16-03035	.118 - .138	.169	NBC16-3-4
-0304	.118 - .157		-3-4.5
-04045	.157 - .177		-4-5
-0405	.157 - .197		-4-5.5
-05055	.197 - .217		-5-6
-0506	.197 - .236		-5-6.5
MPS16-03035	.118 - .138	.181	NBC16-3-4
-0304	.118 - .157		-3-4.5
-04045	.157 - .177		-4-5
-0405	.157 - .197		-4-5.5
-05055	.197 - .217		-5-6
-0506	.197 - .236		-5-6.5
MPS16-03035	.118 - .138	.201	NBC16-3-4
-0304	.118 - .157		-3-4.5
-04045	.157 - .177		-4-5
-0405	.157 - .197		-4-5.5
-05055	.197 - .217		-5-6
-0506	.197 - .236		-5-6.5
MPS16-03035	.118 - .138	.161	NBC16-3-4
-0304	.118 - .157		-3-4.5
-04045	.157 - .177		-4-5
-0405	.157 - .197		-4-5.5
-05055	.197 - .217		-5-6
-0506	.197 - .236		-5-6.5
MPS20-03035	.118 - .138	.157	NBC20-3-4
-0304	.118 - .157		-3-4.5
-04045	.157 - .177		-4-5
-0405	.157 - .197		-4-5.5
-05055	.197 - .217		-5-6
-0506	.197 - .236		-5-6.5
MPS20-03035	.118 - .138	.169	NBC20-3-4
-0304	.118 - .157		-3-4.5
-04045	.157 - .177		-4-5
-0405	.157 - .197		-4-5.5
-05055	.197 - .217		-5-6
-0506	.197 - .236		-5-6.5
MPS20-03035	.118 - .138	.181	NBC20-3-4
-0304	.118 - .157		-3-4.5
-04045	.157 - .177		-4-5
-0405	.157 - .197		-4-5.5
-05055	.197 - .217		-5-6
-0506	.197 - .236		-5-6.5
MPS20-03035	.118 - .138	.201	NBC20-3-4
-0304	.118 - .157		-3-4.5
-04045	.157 - .177		-4-5
-0405	.157 - .197		-4-5.5
-05055	.197 - .217		-5-6
-0506	.197 - .236		-5-6.5
MPS20-03035	.118 - .138	.205	NBC20-3-4
-0304	.118 - .157		-3-4.5
-04045	.157 - .177		-4-5
-0405	.157 - .197		-4-5.5
-05055	.197 - .217		-5-6
-0506	.197 - .236		-5-6.5
MPS20-03035	.118 - .138	.181	NBC20-3-4
-0304	.118 - .157		-3-4.5
-04045	.157 - .177		-4-5
-0405	.157 - .197		-4-5.5
-05055	.197 - .217		-5-6
-0506	.197 - .236		-5-6.5

- 1 pc. of PS Ring is included.
- To supply coolant to the periphery of the cutting tool, Adjusting Screw should not be mounted.

PS RING PAT.

Replaceable seal used in Mega Perfect Seal

(Spare seal is recommended when coolant leaks due to damage of PS Ring.)



1 package contains
5 pcs. (1 size)

US Patent No. 5975817

Model	MPS Model	Model	MPS Model	Model	MPS Model
PS-0304	MPS□-03035, 0304	PS-0809	MPS□-08085, 0809	PS-1314	MPS□-1314
0405	04045, 0405	0910	09095, 0910	1415	1415
0506	05055, 0506	1011	10105, 1011	1516	1516
0607	06065, 0607	1112	11115, 1112	1617	1617
0708	07075, 0708	1213	12125, 1213	1718	1718
				1819	1819
				1920	1920

Collet chuck designed exclusively for end milling with high concentricity and rigidity.



**MAX.
35,000
RPM**

Coolant-through hole

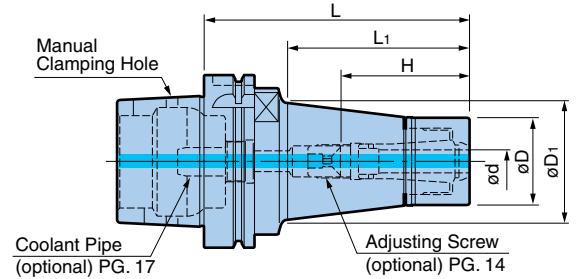

Form A (DIN 69893-1) (ISO 12164)

Model	ød	øD	øD1	L	L1	H	Max. RPM	Collet	Weight (lbs)		
HSK-A40-MEGA6E-60 ※	.125 - .250	.984	1.008	2.36	.94	1.61	35,000	MEC6-□	.86		
-75 ※			1.110	2.95	1.54	2.17			.99		
-90			1.114	3.54	2.13	1.46 - 1.77			25,000	1.15	
-MEGA8E-65 ※	.125 - .250	1.181	1.323	2.56	1.18	1.73	35,000	MEC8-□	1.01		
-75 ※				2.95	1.57	2.13			30,000	1.12	
-90				3.54	2.17	1.65 - 2.01			25,000	1.34	
-MEGA10E-70 ※	.125 - .375	1.378	1.378	2.76	1.38	1.89	30,000	MEC10-□	1.15		
-90				3.54	2.17	1.89 - 2.05			25,000	1.48	
-MEGA13E-70 ※	.125 - .500	1.654	1.654	2.76	1.38	1.97	30,000	MEC13-□	1.37		
-90 ※				3.54	2.17	2.64			25,000	1.78	
HSK-A50-MEGA6E-75	.125 - .250	.984	1.122	2.95	1.38	1.46 - 1.69	30,000	MEC6-□	1.32		
-100			1.291	3.94	2.48	1.46 - 1.77	28,000	1.76			
-MEGA8E-75 ※	.125 - .250	1.181	1.307	2.95	1.50	1.65	30,000	MEC8-□	1.54		
-100			1.425	3.94	2.20	1.65 - 2.01			28,000	1.98	
-MEGA10E-75 ※	.125 - .375	1.378	1.500	2.95	1.56	1.89	30,000	MEC10-□	1.76		
-100			1.567	3.94	2.20	1.89 - 2.28			25,000	1.98	
-MEGA13E-75 ※	.125 - .500	1.654	—	2.95	1.93	1.97	30,000	MEC13-□	1.98		
-100			—	3.94	2.91	1.97 - 2.17			25,000	2.42	
HSK-A63-MEGA6E-65 ※	.125 - .250	.984	1.031	2.56	1.10	1.77	30,000	MEC6-□	1.98		
-90			1.181	3.54	1.97	1.46 - 1.77			29,000	2.20	
-105			1.283	4.13	2.56					2.42	
-120			1.390	4.72	3.15					2.64	
-135			1.492	5.31	3.74					27,000	3.08
-MEGA8E-67 ※	.125 - .250	1.181	1.232	2.64	1.18		1.77	30,000		MEC8-□	1.98
-90			1.370	3.54	1.97	1.46 - 1.77	29,000		2.42		
-105			1.480	4.13	2.60	1.65 - 2.01	28,000		2.64		
-120			1.591	4.72	3.23				28,000		3.08
-135			1.701	5.31	3.86				27,000		3.52
-MEGA10E-75 ※	.125 - .375	1.378	1.472	2.95	1.46			1.89	30,000	MEC10-□	2.42
-90 ※			1.575	3.54	2.05			2.52			29,000
-105			1.685	4.13	2.68	1.89 - 2.28	28,000	3.08			
-120			1.705	4.72	3.27			28,000			3.30
-135			1.685	5.31	3.86			27,000			3.74
-MEGA13E-75 ※	.125 - .500	1.654	1.693	2.95	1.22			1.93	30,000	MEC13-□	2.64
-90 ※			1.764	3.54	1.77			2.52			29,000
-105			1.799	4.13	2.36	1.97 - 2.24	28,000	3.52			
-120			1.862	4.72	2.99			28,000			3.96
-135			1.835	5.31	3.58			26,000			4.19

1. Nut is included. Adjusting screw, collet and wrench must be ordered separately.
2. Coolant pipe must be ordered separately.
3. Adjusting screws cannot be used with models marked ※. H "max" is the maximum tool shank length that can be inserted into the holder.

4. Maximum operating speeds are directly influenced by the rigidity of the machine. Therefore, when determining the optimum cutting conditions, increase the cutting parameters gradually.
5. Weight does not include collet.

Accessories						
Mega E Chuck	Model	Model	Model	G	L	B (mm)
	MGR25	MEC6-□	NBA6B	M7	.47	2
	MGR30	MEC8-□	NBA8B	M9	.51	2.5
	MGR35	MEC10-□	NBA10B	M11	.63	3
	MGR42	MEC13-□	NBA13B	M14	.79	4

Spare Parts	
Mega E Nut	
Model	
MEN6	
MEN8	
MEN10	
MEN13	



**MAX.
24,000
RPM**

(HSK-A100)

Coolant-through hole

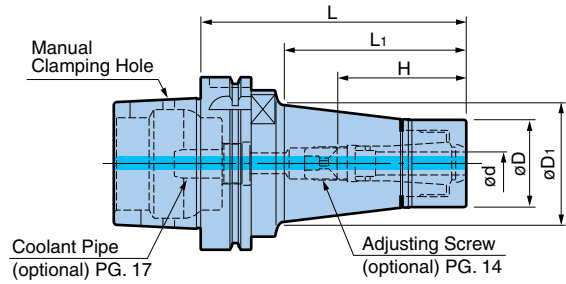

Form A (DIN 69893-1) (ISO 12164)

Model	$\varnothing d$	$\varnothing D$	$\varnothing D1$	L	L1	H	Max. RPM	Collet	Weight (lbs)
HSK-A100-MEGA6E-75 ※	.125 - .250	.984	1.079	2.95	1.30	1.81	24,000	MEC6-□	5.51
-90			1.161	3.54	1.89	1.46 - 1.77	20,000		5.73
-105			1.264	4.13	2.48		18,000		5.95
-120			1.366	4.72	3.07		14,000		6.17
-135			1.472	5.31	3.66		6.39		
-165			1.677	6.50	4.80	7.05			
-MEGA8E-75 ※	.125 - .250	1.181	1.264	2.95	1.30	1.81	24,000	MEC8-□	5.51
-90			1.346	3.54	1.89	1.65 - 2.01	20,000		5.73
-105			1.453	4.13	2.48		18,000		6.17
-120			1.555	4.72	3.07		16,000		6.39
-135			1.657	5.31	3.66		6.83		
-165			1.866	6.50	4.84	7.49			
-MEGA10E-80 ※	.125 - .375	1.378	1.472	3.15	1.50	2.01	22,000	MEC10-□	5.73
-90 ※			1.539	3.54	1.89	2.40	20,000		5.95
-105			1.646	4.13	2.48	1.89 - 2.28	18,000		6.39
-120			1.748	4.72	3.07		16,000		6.83
-135			1.850	5.31	3.66		7.27		
-165			2.059	6.50	4.84		8.15		
-MEGA13E-82 ※	.125 - .500	1.654	1.748	3.23	1.57	2.09	20,000	MEC13-□	6.17
-90 ※			1.803	3.54	1.89	2.40	18,000		6.39
-105			1.909	4.13	2.48	1.97 - 2.68	16,000		6.83
-120			2.012	4.72	3.07		14,000		7.27
-135			2.114	5.31	3.66		7.93		
-165			2.323	6.50	4.84		9.25		

1. Nut is included. Adjusting screw, collet and wrench must be ordered separately.
2. Coolant pipe must be ordered separately.
3. Adjusting screws cannot be used with models marked ※. H "max" is the maximum tool shank length that can be inserted into the holder.

4. Maximum operating speeds are directly influenced by the rigidity of the machine. Therefore, when determining the optimum cutting conditions, increase the cutting parameters gradually.
5. Weight does not include collet.

For ACCESSORIES and SPARE PARTS PG. 14

MEGA E COLLET

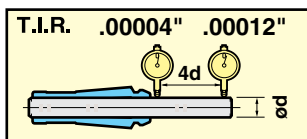
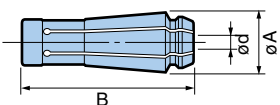

	$\varnothing d$	MEGA6E	MEGA8E	MEGA10E	MEGA13E
		$\varnothing A = .445$ B=1.374	$\varnothing A = .555$ B=1.551	$\varnothing A = .673$ B=1.799	$\varnothing A = .811$ B=1.886
		Model	Model	Model	Model
INCH SIZE	.125	MEC6-1/8AA	MEC8-1/8AA	MEC10-1/8AA	MEC13-1/8AA
	.187	-3/16AA	-3/16AA	-3/16AA	-3/16AA
	.250	-1/4AA	-1/4AA	-1/4AA	-1/4AA
	.312			-5/16AA	-5/16AA
	.375			-3/8AA	-3/8AA
	.437				-7/16AA
METRIC SIZE	.500				-1/2AA
	3.0	MEC6-3AA	MEC8-3AA	MEC10-3AA	MEC13-3AA
	4.0	-4AA	-4AA	-4AA	-4AA
	5.0	-5AA	-5AA	-5AA	-5AA
	6.0	-6AA	-6AA	-6AA	-6AA
	7.0		-7AA	-7AA	-7AA
	8.0		-8AA	-8AA	-8AA
	9.0			-9AA	-9AA
	10.0			-10AA	-10AA
	12.0				-12AA

1. Use only a cutting tool shank with exactly the same diameter as collet bore diameter. The tolerance of the cutting tool shank must be h7.

Simultaneous fit is achieved on the nut as well as the taper shank to obtain rigidity close to an integral body.



**MAX.
28,000
RPM**

Coolant-through hole
For coolant to cutting tool periphery

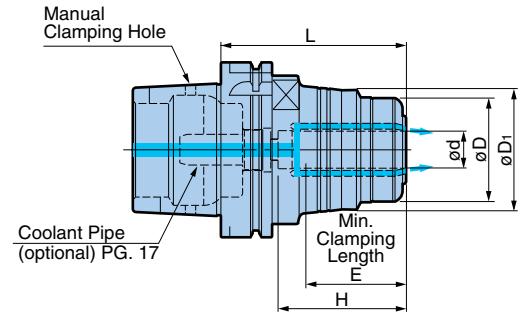

Form A (DIN 69893-1) (ISO 12164)

Model	$\varnothing d$	$\varnothing D$	$\varnothing D1$	L	H	Min. Clamping Length E	Max. RPM	Weight (lbs)
HSK-A63-MEGA.625DS-3.5	.750	1.811	2.165	3.59	2.61	2.1	28,000	3.39
-MEGA.750DS-3.5		2.165	2.193	3.59	2.61	2.3	28,000	3.74
-MEGA.750DS-5		2.165	2.193	5.09	3.44	2.3	25,000	4.85
-MEGA1.000DS-4	1.000	2.441	2.469	4.09	3.11	2.3	24,000	4.41
-MEGA1.250DS-4.5	1.250	2.756	2.783	4.59	3.61	2.7	24,000	4.85
HSK-A100-MEGA.750DS-4	.750	2.362	2.717	4.09	2.85	2.3	18,000	9.03
-MEGA1.000DS-4	1.000	2.756	3.031	4.09	2.87	2.4	18,000	9.91
-MEGA1.250DS-4.5	1.250	3.150	3.386	4.59	3.35	2.9	16,000	11.01

1. Wrench must be ordered separately.
2. Coolant pipe must be ordered separately.

Accessories

Mega Wrench	Mega Double Power Chuck		Mega Double Power Chuck	
	Model	Mega Double Power Chuck	Model	Mega Double Power Chuck
	HSK-A63-MEGA.625DS	MGR46	HSK-A100-MEGA.750DS	MGR60
	-MEGA.750DS	MGR55	-MEGA1.000DS	MGR70
	-MEGA1.000DS	MGR62	-MEGA1.250DS	MGR80
	-MEGA1.250DS	MGR70		

PSC COLLET PAT. US Patent No.6746023

High Precision

For coolant-through tools

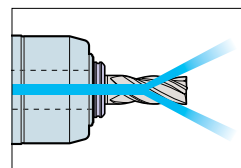

OIL HOLE COLLET

Model	Mega DS Chuck Model
PSC.75-1/4, 3/8, 1/2, 5/8	MEGA.750DS
PSC1.25-1/2, 5/8, 3/4, 7/8, 1	MEGA1.250DS

STRAIGHT COLLET (Type "C")

Reduction sleeve for smaller diameter cutters.



Model		Mega DS Chuck Model
INCH SIZE	C.75-1/4, 5/16, 3/8, 7/16, 1/2, 9/16, 5/8	MEGA.750DS
	C1.00-1/4, 3/8, 1/2, 5/8, 3/4	MEGA1.000DS
	C1.25-1/4, 5/16, 3/8, 7/16, 1/2, 9/16, 5/8, 11/16, 3/4, 13/16, 7/8, 15/16, 1	MEGA1.250DS
METRIC SIZE	C.75-6, 8, 9, 10, 12, 16	MEGA.750DS
	C1.25-12, 14, 16, 20, 25	MEGA1.250DS

Form A KAB TOOL SHANKS

For roughing, finish boring and rigid tapping.



Coolant-through hole

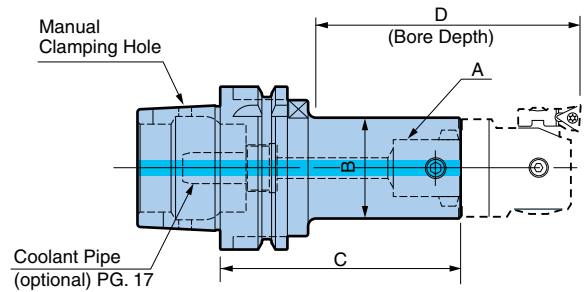

Form A (DIN 69893-1) (ISO 12164)

Catalog Number	Model	A	B	C	D	Weight (lbs)
10.324.331	HSK-A63xKA3xD3.15	KAB3	1.220	2.795	3.149	1.9
10.324.332	xD5.12			4.764	5.118	2.3
10.324.341	xKA4xD4.33	KAB4	1.535	3.700	4.331	2.5
10.324.342	xD5.12			4.488	5.118	2.6
10.324.352	xKA5xD3.35	KAB5	1.968	2.322	3.346	2.1
10.324.353	xD4.53			3.504	4.527	2.9
10.324.361	xKA6xD4.33	KAB6	2.520	2.756	4.331	2.8
10.324.362	xD5.51			3.937	5.512	4.0
10.324.551	HSK-A100xKA5xD5.12	KAB5	1.968	4.213	5.118	5.8
10.324.561	xKA6xD4.53	KAB6	2.520	3.071	4.528	6.4
10.324.563	xD5.71			4.252	5.709	7.6
10.324.571	xKA7xD6.69	KAB7	3.543	3.452	6.693	8.9
10.324.572	xD8.27			5.000	8.268	12.8

1. Dimension "D" with boring head length included.

2. Coolant pipe must be ordered separately.

For KAB system details, please refer to catalog

NO. 308

COOLANT PIPE for Form A and Form E



For machines capable of supplying coolant through the spindle, the Coolant Pipe should be fitted to all HSK holders to protect against accidental selection of coolant.

● Mono Block Type

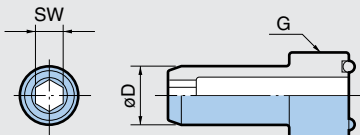

Model	øD	G	SW (mm)
HSK25-CP	.197	M8xP1	2.5
32-CP	.236	M10xP1	3
40-CP	.315	M12xP1	4
50-CP	.394	M16xP1	5
63-CP	.472	M18xP1	6
80-CP	.551	M20xP1.5	8
100-CP	.630	M24xP1.5	8

● 1° Swing Type

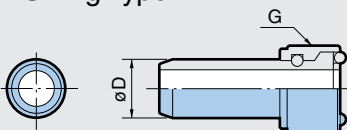

Model	øD	G	Wrench (Optional)
HSK40-CPM	.315	M12xP1	CPW40
50-CPM	.394	M16xP1	CPW50
63-CPM	.472	M18xP1	CPW63
80-CPM	.551	M20xP1.5	CPW80
100-CPM	.630	M24xP1.5	CPW100

Unique feature to compensate for synchronization errors.

License **EMUGE**



Coolant-through hole

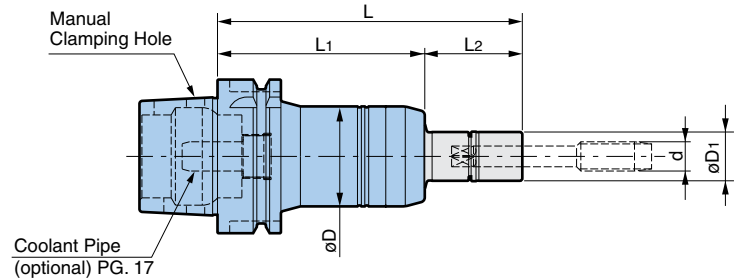
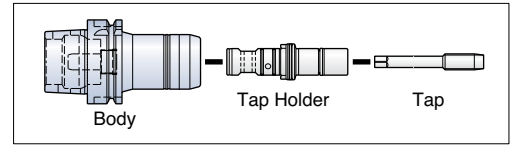

Form A (DIN 69893-1) (ISO 12164)

HSK No.	Model	Tap Holder Model	Tapping Range d*	øD	øD1	L	L1	L2
HSK-A40	HSK-A40-MGT6-80	MGT6-d-1.25S	No.2 - No.12	1.417 (36mm)	.551 (14mm)	4.40	3.150 (80mm)	1.25
		-3S				6.15		3.00
		-4S				7.15		4.00
	-MGT12-85	MGT12-d-1.25	AU1/4 - AU7/16	1.614 (41mm)	.787 (20mm)	4.59	3.346 (85mm)	1.25
		-3				6.34		3.00
		-4				7.34		4.00
HSK-A50	HSK-A50-MGT6-85	MGT6-d-1.25S	No.2 - No.12	1.417 (36mm)	.551 (14mm)	4.59	3.346 (85mm)	1.25
		-3S				6.34		3.00
		-4S				7.34		4.00
	-MGT12-85	MGT12-d-1.25	AU1/4 - AU7/16	1.614 (41mm)	.787 (20mm)	4.59	3.346 (85mm)	1.25
		-3				6.34		3.00
		-4				7.34		4.00
	-MGT20-125	MGT20-d-1.5	AU1/2 - AU3/4 AP1/8 - AP1/4	2.126 (54mm)	1.181 (30mm)	6.42	4.921 (125mm)	1.50
		-3.5				8.42		3.50
		-4.5				9.42		4.50
HSK-A63	HSK-A63-MGT6-85	MGT6-d-1.25S	No.2 - No.12	1.417 (36mm)	.551 (14mm)	4.59	3.346 (85mm)	1.25
		-3S				6.34		3.00
		-4S				7.34		4.00
	-MGT12-85	MGT12-d-1.25	AU1/4 - AU7/16	1.614 (41mm)	.787 (20mm)	4.59	3.346 (85mm)	1.25
		-3				6.34		3.00
		-4				7.34		4.00
	-MGT20-110	MGT20-d-1.5	AU1/2 - AU3/4 AP1/8 - AP1/4	2.126 (54mm)	1.181 (30mm)	5.83	4.331 (110mm)	1.50
		-3.5				7.83		3.50
		-4.5				9.83		4.50
HSK-A100	HSK-A100-MGT6-95	MGT6-d-1.25S	No.2 - No.12	1.417 (36mm)	.551 (14mm)	4.99	3.740 (95mm)	1.25
		-3S				6.74		3.00
		-4S				7.74		4.00
	-MGT12-95	MGT12-d-1.25	AU1/4 - AU7/16	1.614 (41mm)	.787 (20mm)	4.99	3.740 (95mm)	1.25
		-3				6.74		3.00
		-4				7.74		4.00
	-MGT20-115	MGT20-d-1.5	AU1/2 - AU3/4 AP1/8 - AP1/4	2.126 (54mm)	1.181 (30mm)	6.02	4.528 (115mm)	1.50
		-3.5				8.02		3.50
		-4.5				9.02		4.50

1. Tap holder and wrench must be ordered separately.
 2. Rigid tapping function is required on the machine tool.
 3. Coolant pipe must be ordered separately.
- * AU3/8 is included in the MGT20 series.

For TAP HOLDER PG. 19
For MEGA WRENCH PG. 20

■ **TAP HOLDER** (MGT6, MGT12, MGT20)

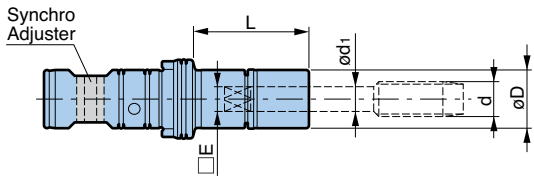

MGT Type	Tap Holder Model	Tapping Range d	ød ₁	□E	L	
MGT6 (D=.472)	MGT6-No.6-1.25S	No.2-6	.141	.110	1.25	
	-3S				3.00	
	-4S				4.00	
	-No.8-1.25S	No.8	.168	.131	1.25	
					-3S	3.00
					-4S	4.00
	-No.10-1.25S	No.10	.194	.152	1.25	
					-3S	3.00
					-4S	4.00
	-No.12-1.25S	No.12	.220	.165	1.25	
					-3S	3.00
					-4S	4.00
MGT12 (D=.787)	MGT12-AU1/4-1.25	AU1/4	.255	.191	1.25	
	-3				3.00	
	-4				4.00	
	-AU5/16-1.25	AU5/16	.318	.238	1.25	
					-3	3.00
	-4	AU7/16	.323	.242	1.25	
					-3	3.00
	-4				4.00	
MGT20 (D=1.181)		MGT20-AU1/2-1.5	AU1/2	.367	.275	1.50
	-3.5	3.50				
	-4.5	4.50				
	-AU3/8-1.5	AU3/8	.381	.286	1.50	
					-3.5	3.50
					-4.5	4.50
	-AU9/16-1.5	AU9/16	.429	.322	1.50	
					-3.5	3.50
					-4.5	4.50
	-AU5/8-1.5	AU5/8	.480	.360	1.50	
					-3.5	3.50
					-4.5	4.50
	-AU11/16-1.5	AU11/16	.542	.406	1.50	
					-3.5	3.50
					-4.5	4.50
	-AU3/4-1.5	AU3/4	.590	.442	1.50	
					-3.5	3.50
					-4.5	4.50
	-AP1/8-1.5	AP1/8	.4375	.328	1.50	
					-3.5	3.50
-4.5					4.50	
-AP1/4-1.5	AP1/4	.5625	.421	1.50		
				-3.5	3.50	
				-4.5	4.50	

1. Nut is included. Wrench must be ordered separately.

Tap Holders with other standards such as JIS or DIN are available from stock upon request. Please contact us for order information.

Accessories

■ MGT SET SCREW (Made of high-strength material)

Secures the Tap Holder into body.

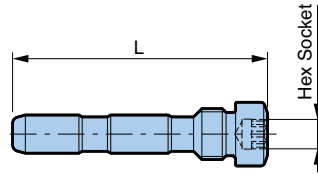

Model	Hex Socket Size	L	Body
MGT6SS	4mm	35mm	MGT6
MGT12SS	4mm	40mm	MGT12
MGT20SS	5mm	53mm	MGT20

■ SYNCHRO ADJUSTER (Made of special material)

Replaceable bushing in Tap Holder

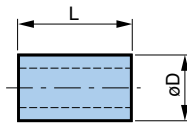

Model	øD	L	Body
MGT6SA	9mm	11mm	MGT6
MGT12SA	10mm	15mm	MGT12
MGT20SA	14mm	24mm	MGT20

1. Sold in packages of 5 pcs.

■ O RING SET

Set includes 1 small, 1 large, 2 middle sizes

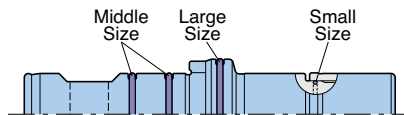

Set Model	Tap Holder
MGT6SOR	MGT6-d-□S
MGT12OR	MGT12-d-□
MGT20OR	MGT20-d-□

■ MGT NUT

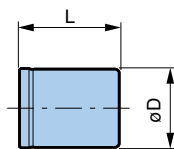

Model	øD	L	Tap Holder
MGN6TS	14mm	19mm	MGT6-d-□S
MGN12T	20mm	21mm	MGT12-d-□
MGN20T	30mm	24mm	MGT20-d-□

■ MEGA WRENCH

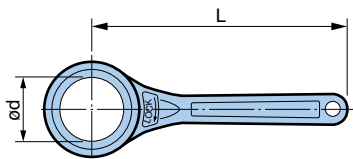

Model	ød	L	Nut
MGR14	14mm	3.54	MGN6TS
MGR20L	20mm	6.30	MGN12T
MGR30L	30mm	8.66	MGN20T

The indexable end mill that combines sharpness and rigidity for smooth, chatter-free cutting.

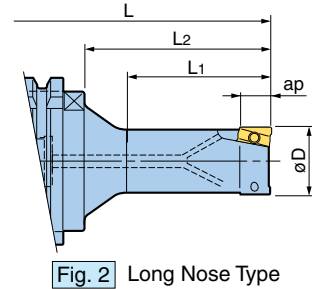
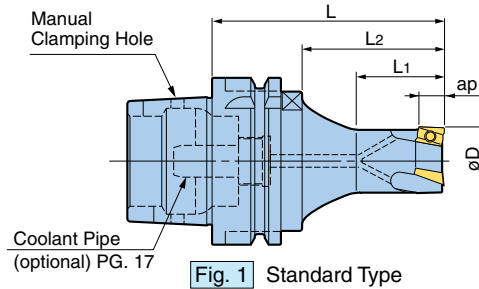

Standard Type Form A (DIN 69893-1) (ISO 12164)

Cutter Dia. øD (inch)	Model	Fig.	ap	L	L1	L2	No. of Inserts	Insert Size	Weight (lbs)			
16mm (.630)	HSK-A40-FCM16092-65	1	.354	2.56	.91	1.46	2	ARG16	.7			
20mm (.787)	-FCM20093-65				1.10			ARG20	.7			
25mm (.984)	-FCM25093-65				1.38		ARG25	.9				
32mm (1.260)	-FCM32113-65				.433	1.77	—	4	ARG40	1.3		
40mm (1.575)	-FCM40114-65							5	ARG40	1.5		
50mm (1.969)	-FCM50115-65											
16mm (.630)	HSK-A50-FCM16092-75	1	.354	2.95	.91	1.61	2	ARG16	1.3			
20mm (.787)	-FCM20093-75				1.10			ARG20	1.3			
25mm (.984)	-FCM25093-75				1.30		ARG25	1.3				
32mm (1.260)	-FCM32113-75				.433	1.54	—	3	ARG32	1.5		
40mm (1.575)	-FCM40114-75							4	ARG40	2.0		
50mm (1.969)	-FCM50115-75	5	ARG40	2.2								
16mm (.630)	HSK-A63-FCM16092-85	1	.354	3.35	.91	2.01	2	ARG16	2.0			
	-105				4.13	1.18			2.80	2.2		
	-120				4.72	.98			3.39	2.4		
	-150				5.91	.98			4.57	2.9		
20mm (.787)	-FCM20093-85		.354	3.35	1.10	2.01	3	ARG20	2.2			
	-105								4.13	1.38	2.80	2.4
	-120								4.72	1.18	3.39	2.6
	-150								5.91	1.18	4.57	3.1
25mm (.984)	-FCM25093-85		.354	3.35	1.30	2.01	3	ARG25	2.2			
	-120								4.72	1.77	3.39	2.6
	-135								5.32	1.58	3.98	2.9
	-165								6.50	1.58	5.16	3.3
32mm (1.260)	-FCM32113-85		.433	3.35	1.45	2.01	3	ARG32	2.4			
	-120								4.72	2.36	3.39	2.9
	-135								5.32	1.97	3.98	3.1
	-165								6.50	1.58	5.16	3.7
40mm (1.575)	-FCM40114-85	.433	3.35	1.69	2.01	4	ARG40	2.9				
	-120							4.72	2.56	3.39	3.3	
	-135							5.32	2.36	3.98	3.7	
	-165							6.50	1.97	5.16	4.6	
50mm (1.969)	-FCM50115-70	.433	2.75	1.10	1.10	5	ARG40	2.9				
	-120							4.72	3.07	3.07	4.2	
	-135							5.32	3.66	3.66	4.8	
	-165							6.50	4.84	4.84	6.2	

1. Coolant pipe must be ordered separately.

2. Inserts must be ordered separately.

3. ap= Length of effective cutting edge.

Long Nose Type Form A (DIN 69893-1) (ISO 12164)

Cutter Dia. øD (inch)	Model	Fig.	ap	L	L1	L2	No. of Inserts	Insert Size	Weight (lbs)
16mm (.630)	HSK-A63-FCM16092L-85	2	.354	3.35	1.57	2.01	2	ARG16	2.0
	-120			4.72	1.77	3.39			2.2
20mm (.787)	-FCM20092L-105		.354	4.13	1.97	2.80	2	ARG20	2.4
	-120				4.72	2.36			3.39
25mm (.984)	-FCM25092L-105		.354	4.13	2.17	2.80	2	ARG25	2.4
	-120				4.72	2.56			3.39
32mm (1.260)	-FCM32112L-120		.433	4.72	2.76	3.39	2	ARG32	2.9
	-135				5.32	3.15			3.98

1. Coolant pipe must be ordered separately.

2. Inserts must be ordered separately.

3. ap= Length of effective cutting edge.

INDEXABLE INSERTS



Marking Description

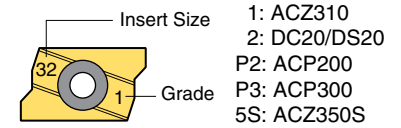

Cutter Dia. \varnothing D (inch)	Insert Model	ap	Nose Radius (inch)	P		M	K	N	
				ACP200	ACP300	ACZ350S	ACZ310	DC20	DS20
16mm (.630)	ARG160902	.354	R0.2 (.008)		○	○	○	○	
	ARG160904		R0.4 (.016)	○	○	○	○		○
20mm (.787)	ARG200902	.354	R0.2 (.008)		○	○	○	○	
	ARG200904		R0.4 (.016)	○	○	○	○		○
25mm (.984)	ARG250902	.354	R0.2 (.008)		○	○	○	○	
	ARG250904		R0.4 (.016)	○	○	○	○		○
32mm (1.260)	ARG321102	.433	R0.2 (.008)		○	○	○	○	
	ARG321104		R0.4 (.016)	○	○	○	○		○
40mm (1.575) 50mm (1.969)	ARG401102	.433	R0.2 (.008)		○	○	○	○	
	ARG401104		R0.4 (.016)	○	○	○	○		○

1. Inserts are available in packets of 10 pcs.
2. Please clarify the insert type and grade when ordering.
For example, use ordering code: ARG160902ACP200.

Caution

Fullcut Mill uses a different insert for each cutter diameter (except for dia. 40mm and 50mm).
If an incorrect insert is used, a problem will result.
There is no compatibility with those of FCR Type.

Insert Classifications

ISO Material	Grade	Material	Coating
P20	ACP200	Prehardened Steel	TiAlN / AlCrN
P30	ACP300	General Steel	
M30	ACZ350S	Stainless Steel	TiAlN / TiCN
K10	ACZ310	Cast Iron	
N20	DC20	Aluminum	DLC
	DS20		

Selection between ACP300 and ACP200 for steel.

ACP200 is superior in anti-wear resistance, while ACP300 is superior in its anti-chipping property. ACP300 is the first recommendation for cutting steel.
Choose ACP200 over ACP300 in cases where further speed or wear-resistance is needed. ACP200 is not, however, recommended for either heavily-interrupted or heavy-duty cutting.

SPARE PARTS

		Insert Clamping Screw Set (10) screws & (1) wrench	Wrench	Anti-Seizure Lubricant 5g included
Cutter Dia. (inch)	Insert	Model	Model	Model
16mm (.630)	ARG1609□□	S2506DS	DA-T8	BN-5
20mm (.787)	ARG2009□□			
25mm (.984)	ARG2509□□			
32mm (1.260)	ARG3211□□	S3508DS	DA-T15	
40mm (1.575)	ARG4011□□			
50mm (1.969)				



Note

It is recommended to regularly replace clamping screws and wrench to ensure the correct clamping force is maintained.

Form A FULLCUT MILL Type FCR

Unique inserts designed for ramping make multi-functional cutting possible.

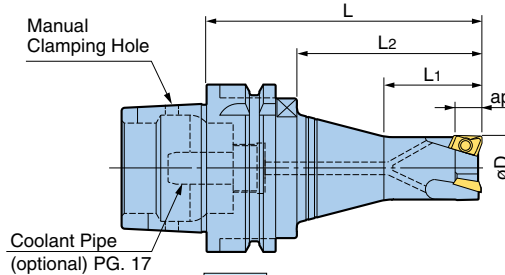
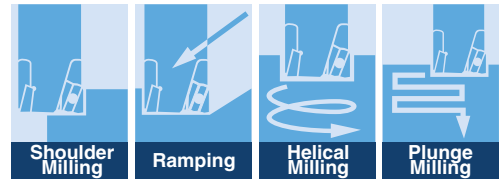

Fig. 1 Standard Type

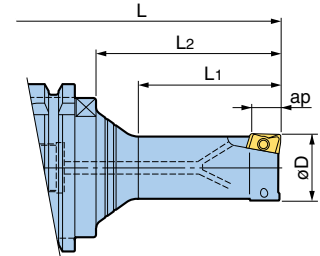

Fig. 2 Long Nose Type

Standard Type Form A (DIN 69893-1) (ISO 12164)

Cutter Dia. øD (inch)	Model	Fig.	ap	L	L1	L2	No. of Inserts	Insert Size	Weight (lbs)		
16mm (.630)	HSK-A50-FCR16082-75	1	.315	2.95	1.06	1.61	2	BRG16	1.1		
20mm (.787)	-FCR20083-75				1.10		3	BRG20	1.3		
25mm (.984)	-FCR25083-75				1.30		3	BRG25	1.3		
32mm (1.260)	-FCR32103-75				1.54		3	BRG32	1.5		
16mm (.630)	HSK-A63-FCR16082-85	1	.315	3.35	.98	2.01	2	BRG16	2.0		
	-120				1.18	3.39			2.4		
	-135				.98	3.98			2.6		
20mm (.787)	-FCR20083-85				.315	3.35	1.26	2.01	3	BRG20	2.2
	-120						1.18	3.39			2.6
	-135						1.18	3.98			2.9
25mm (.984)	-FCR25083-85				.315	3.35	1.38	2.01	3	BRG25	2.2
	-120						1.77	3.39			2.6
	-135						1.38	3.98			3.1
32mm (1.260)	-FCR32103-85	.394	3.35	1.58	2.01	3	BRG32	2.4			
	-120			1.97	3.39			3.1			
	-135			1.58	3.98			3.3			

- Coolant pipe must be ordered separately.
- Inserts must be ordered separately.
- ap= Length of effective cutting edge.

Long Nose Type Form A (DIN 69893-1) (ISO 12164)

Cutter Dia. øD (inch)	Model	Fig.	ap	L	L1	L2	No. of Inserts	Insert Size	Weight (lbs)
16mm (.630)	HSK-A63-FCR16082L-85	2	.315	3.35	1.57	2.01	2	BRG16	2.0
	-120			4.72	1.77	3.39			2.2
20mm (.787)	-FCR20082L-105		.315	4.13	1.97	2.80	2	BRG20	2.4
	-120				2.36	3.39			2.6
25mm (.984)	-FCR25082L-105		.315	4.13	2.17	2.80	2	BRG25	2.4
	-120				2.56	3.39			2.4
32mm (1.260)	-FCR32102L-120		.394	4.72	2.76	3.39	2	BRG32	3.1
	-135				3.15	3.98			3.1

- Coolant pipe must be ordered separately.
- Inserts must be ordered separately.
- ap= Length of effective cutting edge.

INDEXABLE INSERTS



Marking Description

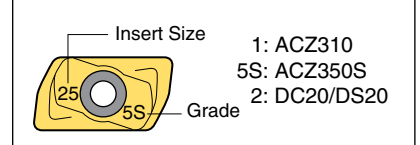

Cutter Dia. \varnothing D (inch)	Insert Model	ap	Nose Radius (inch)	P	M	K	N	
				ACZ350S	ACZ310	DC20	DS20	
16mm (.630)	BRG160808	.315	R0.8 (.031)	○		○		○
20mm (.787)	BRG200808	.315	R0.8 (.031)	○		○		○
25mm (.984)	BRG250808	.315	R0.8 (.031)	○		○		○
32mm (1.260)	BRG321008	.394	R0.8 (.031)	○		○		○
	BRG321032	.394	R3.2 (.125)				○	

1. Inserts are available in packets of 10 pcs.
2. Please clarify the insert type and grade when ordering.
For example, use ordering code: BRG160808ACZ350S.

⚠ Caution

Fullcut Mill uses a different insert for each cutter diameter. If an incorrect insert is used, a problem will result.

There is no compatibility with those of FCM Type.

Insert Classifications

ISO Material	Grade	Material	Coating
P30	ACZ350S	General Steel	TiAlN / TiCN
M30		Stainless Steel	
K10	ACZ310	Cast Iron	
N20	DC20	Aluminum	DLC
	DS20		

SPARE PARTS

		Insert Clamping Screw Set	Wrench	Anti-Seizure Lubricant
		<p>(10) screws & (1) wrench</p>		<p>5g included</p>
Cutter Dia. (inch)	Insert	Model	Model	Model
16mm (.630)	BRG1608 □□	S2506DS	DA-T8	BN-5
20mm (.787)	BRG2008 □□			
25mm (.984)	BRG2508 □□			
32mm (1.260)	BRG3210 □□	S3508DS	DA-T15	



Note

It is recommended to regularly replace clamping screws and wrench to ensure the correct clamping force is maintained.

Extremely slim design of nut and tapered body provides superior balance and concentricity and is ideal for reaching into confined areas.



**MAX.
50,000
RPM**

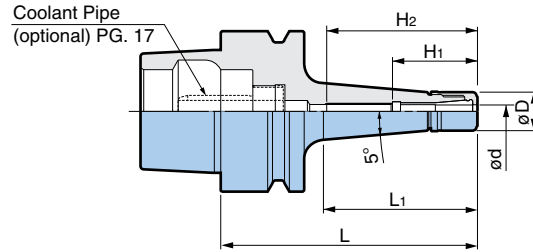

Type T Form E (DIN V 69893-5)

Model	ød	øD	L	L1	H1	H2	Max. RPM	Collet	Weight (lbs)
HSK-E25-MEGA3S-45T ※	.018 - .128	.394	1.77	1.26	.87	(1.26)	50,000	NBC3S-□	.13
-60T			2.36	1.89		1.50	40,000		.18
-MEGA4S-45T ※	.018 - .159	.472	1.77	1.26	1.04	(1.26)	50,000	NBC4S-□	.15
-60T			2.36	1.89		1.61	40,000		.22
-MEGA6S-45T ※	.018 - .238	.551	1.77	1.26	1.12	(1.22)	50,000	NBC6S-□	.18
-60T			2.36	1.89		1.57	40,000		.22
HSK-E32-MEGA3S-60T	.018 - .128	.394	2.36	1.34	.87	1.50	40,000	NBC3S-□	.33
-75T			2.95	1.93					.37
-MEGA4S-45T ※	.018 - .159	.472	1.77	.91	1.04	(1.02)	50,000	NBC4S-□	.31
-60T			2.36	1.34		1.81	40,000		.35
-MEGA6S-45T ※	.018 - .238	.551	1.77	.91	1.12	(1.10)	50,000	NBC6S-□	.31
-60T			2.36	1.38		1.50	40,000		.37
HSK-E40-MEGA3S-60T	.018 - .128	.394	2.36	1.34	.87	1.54	40,000	NBC3S-□	.51
-75T			2.95	1.93		1.50			.55
-MEGA4S-60T	.018 - .159	.472	2.36	1.34	1.04	1.73	40,000	NBC4S-□	.53
-75T			2.95	1.93		1.85			.59
-MEGA6S-60T ※	.018 - .238	.551	2.36	1.34	1.12	(1.10)	40,000	NBC6S-□	.53
-75T			2.95	1.93		1.93			.62
-90T			3.54	2.52		.70			
HSK-E50-MEGA3S-80T	.018 - .128	.394	3.15	1.89	.87	1.50	40,000	NBC3S-□	1.01
-MEGA4S-80T	.018 - .159	.472	3.15	1.89	1.04	1.85	40,000	NBC4S-□	1.04
-MEGA6S-80T	.018 - .238	.551	3.15	1.89	1.12	1.93	40,000	NBC6S-□	1.06

1. Nut is included. Collet and wrench must be ordered separately.
2. For models marked ※, there is no internal thread.
The dimension H2 in () shows how deep a tool can be inserted.
3. Maximum operating speeds are directly influenced by the rigidity of the machine.
Therefore, when determining the optimum cutting conditions, increase the cutting parameters gradually.
4. Coolant pipe must be ordered separately.
5. Weight does not include collet.

For ACCESSORIES and SPARE PARTS PG. 6



MAX.
50,000
RPM

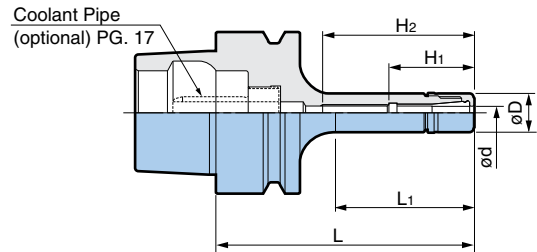

Type S Form E (DIN V 69893-5)

Model	$\varnothing d$	$\varnothing D$	L	L1	H1	H2	Max. RPM	Collet	Weight (lbs)
HSK-E25-MEGA3S-35 ●	.018 - .128	.394	1.38	.87	.87	.94	50,000	NBC3S-□	.11
-MEGA4S-35 ※ ●	.018 - .159	.472	1.38	.87	1.02	(1.02)	50,000	NBC4S-□	.13
-45 ※			1.77	1.18	1.04	(1.26)	40,000		.13
-60			2.36	1.77	1.85	40,000	.18		
-MEGA6S-45 ※	.018 - .238	.551	1.77	1.26	1.10	(1.22)	50,000	NBC6S-□	.15
-60			2.36	1.81	1.12	1.61	40,000		.18
HSK-E32-MEGA3S-45 ※	.018 - .128	.394	1.77	.87	.87	(1.22)	50,000	NBC3S-□	.29
-MEGA4S-45	.018 - .159	.472	1.77	.87	1.04	1.22	50,000	NBC4S-□	.31
-60			2.36	1.30		1.81	40,000		.33
-MEGA6S-45 ※	.018 - .238	.551	1.77	.87	1.12	(1.10)	50,000	NBC6S-□	.31
-60			2.36	1.34		1.50	40,000		.33
HSK-E40-MEGA3S-40 ※	.018 - .128	.394	1.57	.75	.87	(.94)	50,000	NBC3S-□	.46
-MEGA4S-40 ●	.018 - .159	.472	1.57	.75	1.04	1.06	50,000	NBC4S-□	.46
-60			2.36	1.30		1.73	40,000		.51
-MEGA6S-45 ※	.018 - .238	.551	1.77	.91	1.12	(1.06)	50,000	NBC6S-□	.48
-60			2.36	1.34		1.10	40,000		.51
HSK-E50-MEGA3S-50 ※	.018 - .128	.394	1.97	.79	.87	(1.38)	45,000	NBC3S-□	.93
-MEGA4S-50 ※	.018 - .159	.472	1.97	.83	1.04	(1.18)	45,000	NBC4S-□	.95
-80			3.15	1.69		1.85	40,000		.99
-MEGA6S-55 ※	.018 - .238	.551	2.17	1.02	1.12	(1.38)	45,000	NBC6S-□	.95
-80			3.15	1.69		1.93	40,000		1.01

- Nut is included. Collet and wrench must be ordered separately.
- For models marked ※, there is no internal thread.
The dimension H₂ in () shows how deep a tool can be inserted.
- Maximum operating speeds are directly influenced by the rigidity of the machine.
Therefore, when determining the optimum cutting conditions, increase the cutting parameters gradually.
- Coolant pipe must be ordered separately.
- Coolant pipe cannot be used with models marked ●.
- Weight does not include collet.

For ACCESSORIES and SPARE PARTS PG. 6

High speed design utilizes ultra precision New Baby Collet which guarantees a runout at the collet nose of less than .00004".

MAX.
40,000
RPM

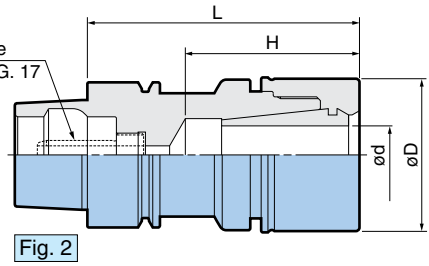
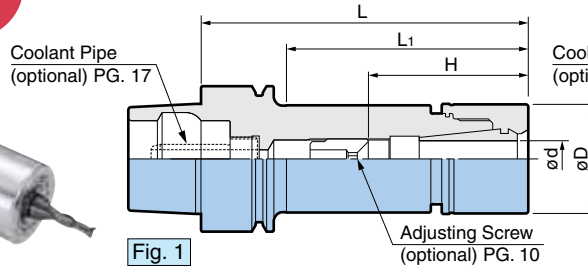

Form E (DIN V 69893-5)

Model	Fig.	ød	øD	L	L1	H	Max. RPM	Collet	Weight (lbs)
HSK-E25-MEGA6N-40 ※	1	.010 - .236	.787	1.57	1.10	1.10	30,000	NBC6-□	.22
-MEGA8N-45 ※	2	.020 - .315	.984	1.77	—	1.26	25,000	NBC8-□	.26
-MEGA10N-60 ※		.059 - .394	1.181	2.36	—	1.38	20,000	NBC10-□	.37
HSK-E32-MEGA6N-45 ※	1	.010 - .236	.787	1.77	.94	1.18	40,000	NBC6-□	.37
-60				2.36	1.42	.91 - 1.18	35,000		.44
-MEGA8N-50 ※	1	.020 - .315	.984	1.97	1.14	1.46	40,000	NBC8-□	.48
-65				2.56	1.69	1.02 - 1.38	35,000		.59
-MEGA10N-65 ※	2	.059 - .394	1.181	2.56	1.77	1.97	30,000	NBC10-□	.62
-MEGA13N-70 ※	2	.098 - .512	1.378	2.76	1.77	1.73	25,000	NBC13-□	.68
HSK-E40-MEGA6N-50 ※	1	.010 - .236	.787	1.97	1.02	1.38	40,000	NBC6-□	.57
-60				2.36	1.30	.91 - 1.30	35,000		.62
-75				2.95	1.89	.91 - 1.62	30,000		.68
-90				3.54	2.48	—	28,000		.77
-120				4.72	3.66	.91 - 1.69	25,000		.90
-MEGA8N-55 ※	1	.020 - .315	.984	2.17	1.22	1.57	40,000	NBC8-□	.68
-75				2.95	1.97	1.02 - 1.77	30,000		.84
-90				3.54	2.56	—	28,000		.95
-MEGA10N-60 ※	1	.059 - .394	1.181	2.36	1.42	1.77	35,000	NBC10-□	.86
-75 ※				2.95	2.01	2.24	30,000		1.01
-90				3.54	2.60	1.50 - 1.89	28,000		1.17
-MEGA13N-65 ※	1	.098 - .512	1.378	2.56	1.69	1.73	30,000	NBC13-□	.99
-75 ※				2.95	2.09	2.28	25,000		1.17
-90				3.54	2.68	1.73 - 2.09	25,000		1.37
-120				4.72	3.86	—	20,000		1.76
-150	5.91	5.04	1.73 - 2.48	15,000	2.20				
-MEGA16N-65 ※	2	.098 - .630	1.654	2.56	—	1.81	25,000	NBC16-□	.95
-75 ※				2.95	—	1.89	20,000		1.32
				2.17	1.06	1.38	40,000		1.04
HSK-E50-MEGA6N-55 ※	1	.010 - .236	.787	2.76	1.46	.91 - 1.54	30,000	NBC6-□	1.10
-70				3.94	2.48	—	25,000		1.23
-100				5.12	3.66	.91 - 1.69	20,000		1.39
-130				2.36	1.18	1.47	40,000		1.15
-MEGA8N-60 ※	1	.020 - .315	.984	3.54	2.17	1.02 - 1.69	30,000	NBC8-□	1.37
-90				2.36	1.18	1.38	35,000		1.23
-MEGA10N-60 ※	1	.059 - .394	1.181	3.54	2.24	1.50 - 1.89	30,000	NBC10-□	1.54
-90				2.36	1.22	1.73	30,000		1.32
-MEGA13N-60 ※ ●	1	.098 - .512	1.378	2.76	1.57	1.77	28,000	NBC13-□	1.47
-70 ※				3.54	2.32	1.73 - 2.64	25,000		1.76
-90				4.72	3.50	—	20,000		2.20
-120				5.91	4.69	1.73 - 2.48	15,000		2.73
-150				2.56	1.54	1.89	30,000		1.61
-MEGA16N-65 ※ ●	1	.098 - .630	1.654	2.95	1.89	2.05	28,000	NBC16-□	1.87
-75 ※				3.54	2.44	2.56	25,000		2.20
-90 ※				2.95	—	1.93	25,000		1.76
-MEGA20N-75 ※	2	.098 - .787	1.811	3.94	—	2.01 - 2.13	20,000	NBC20-□	2.42
-100				5.12	—	—	18,000		3.30
-130				6.30	—	2.01 - 2.68	15,000		3.96
-160				—	—	—	—		—

- Nut is included. Adjusting screw, collet and wrench must be ordered separately.
- Adjusting screws cannot be used with models marked ※. H "max" is the maximum tool shank length that can be inserted into the holder.
- Maximum operating speeds are directly influenced by the rigidity of the machine. Therefore, when determining the optimum cutting conditions, increase the cutting parameters gradually.
- Coolant pipe must be ordered separately.
- Coolant pipe cannot be used with models marked ●.
- Weight does not include collet.

➡ For ACCESSORIES and SPARE PARTS PG. 10

Form E KAB TOOL SHANKS

For roughing and finish boring.

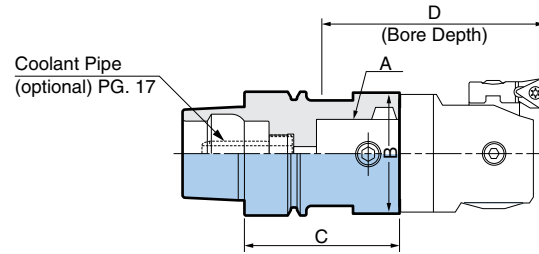

Form E (DIN V 69893-5)

Catalog Number	Model	A	B	C	D	Weight (lbs)
10.324.141	HSK-E40xKA4xD2.84	KAB4	1.535	1.968	2.835	1.0
10.324.251	HSK-E50xKA5xD3.43	KAB5	1.968	2.402	3.425	1.1

1. Dimension "D" with boring head length included.
2. Coolant pipe must be ordered separately.

For KAB system details, please refer to catalog

NO. 308

Form E FULLCUT MILL Type FCM

Cutter Dia: \varnothing .630"

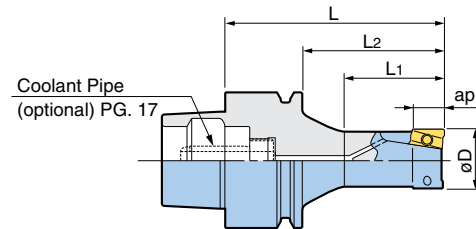

Standard Type Form E (DIN V 69893-5)

Cutter Dia. $\varnothing D$ (inch)	Model	ap	L	L1	L2	No. of Inserts	Insert Size	Weight (lbs)
16mm (.630)	HSK-E25-FCM16092-45	.354	1.77	.91	1.38	2	ARG16	.4
	-E32-FCM16092-55		2.17	.91	1.38			.4
	-E40-FCM16092-65		2.56	1.10	1.77			1.0

1. Coolant pipe must be ordered separately.
2. Inserts must be ordered separately.
3. ap= Length of effective cutting edge.

For INSERTS PG. 22



Caution

As the HSK-E type interface does not have drive key-ways, there is a possibility that it may slip in the machine tool spindle if the cutting load exceeds the gripping force of the machine tool.

Please try to choose proper cutting conditions for the Fullcut Mill because its performance is affected by the machine tool.

Extremely slim design of nut and tapered body provides superior balance and concentricity and is ideal for reaching into confined areas.



MAX.
32,000
RPM

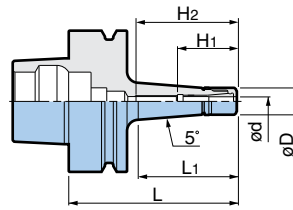

Fig. 1 Type T

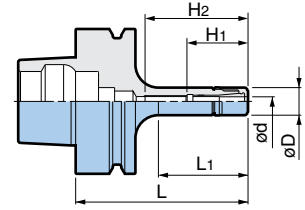

Fig. 2 Type S

Form F (DIN V 69893-6)

Model	Fig.	ød	øD	L	L1	H1	H2	Max. RPM	Collet	Weight (lbs)
HSK-F63-MEGA4S-75T	1	.018 - .159	.472	2.95	1.69	1.04	1.61	32,000	NBC4S-□	1.54
-MEGA6S-75T		.018 - .238	.551	2.95	1.69	1.12	1.61	32,000	NBC6S-□	1.54
HSK-F63-MEGA4S-75	2	.018 - .159	.472	2.95	1.50	1.04	1.61	30,000	NBC4S-□	1.54
-105				4.13	2.68		1.85	25,000		1.54
HSK-F63-MEGA6S-75		.018 - .238	.551	2.95	1.50	1.04	1.61	30,000	NBC6S-□	1.54
				-90	3.54		2.13	1.12		1.93
-105				4.13	2.68			25,000		1.65

- Nut is included. Collet and wrench must be ordered separately.
- Maximum operating speeds are directly influenced by the rigidity of the machine. Therefore, when determining the optimum cutting conditions, increase the cutting parameters gradually.
- Weight does not include collet.
- Models ending in T designates Taper Type.

➡ For ACCESSORIES and SPARE PARTS PG. 6

The body, collet, nut and wrench are specifically designed for high speed operations.



MAX.
35,000
RPM

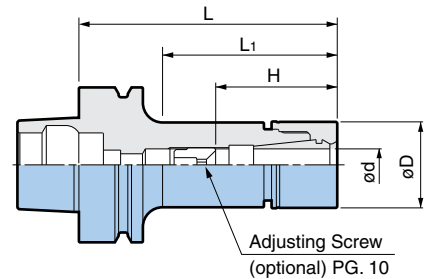

Adjusting Screw (optional) PG. 10

Form F (DIN V 69893-6)

Model	ød	øD	L	L1	H	Max. RPM	Collet Model	Weight (lbs)
HSK-F63-MEGA6N-75	.010 - .236	.787	2.95	1.65	.91 - 1.22	35,000	NBC6-□	1.54
-90			3.54	2.09		30,000		1.76
-105			4.13	2.68	.91 - 1.69	25,000		1.76
-135			5.31	3.86		20,000		1.98
-MEGA8N-75			.020 - .315	.984	2.95	1.65		1.02 - 1.50
-90	3.54	2.09			30,000	1.98		
-105	4.13	2.68			1.02 - 1.77	25,000	1.98	
-120	4.72	3.27					1.98	
-135	5.31	3.86					2.20	
-165	6.50	5.04				15,000	2.42	
-MEGA10N-75 ※	.059 - .354	1.181			2.95	1.65	1.89	32,000
-90			3.54	2.09	30,000	1.98		
-105			4.13	2.68	1.50 - 1.69	25,000	2.20	
-120			4.72	3.27			2.42	
-MEGA13N-75 ※	.098 - .512	1.378	2.95	1.65	1.85	30,000	NBC13-□	1.98
-90 ※			3.54	2.17				2.40
-105			4.13	2.76	1.73 - 2.09	25,000		2.42
-120			4.72	3.35				20,000
-65			6.50	5.12	1.73 - 2.48	15,000		3.52
-MEGA16N-75 ※	.098 - .630	1.654	2.95	1.65	1.89	30,000	NBC16-□	2.20
-90 ※			3.54	2.24		2.40		25,000
-105			4.13	2.83	1.89 - 2.20	20,000		2.86
-MEGA20N-75 ※	.098 - .787	1.811	2.95	1.73	2.01	30,000	NBC20-□	2.42
-90 ※			3.54	2.32		2.40		25,000
-105			4.13	2.91	2.01 - 2.28	20,000		3.08

- Nut is included. Adjusting screw, collet and wrench must be ordered separately.
- Adjusting screws cannot be used with models marked ※. H "max" is the maximum tool shank length that can be inserted into the holder.
- Maximum operating speeds are directly influenced by the rigidity of the machine. Therefore, when determining the optimum cutting conditions, increase the cutting parameters gradually.
- Weight does not include collet.

➡ For ACCESSORIES and SPARE PARTS PG. 10

Collet chuck designed exclusively for end milling with high concentricity and rigidity.



MAX.
30,000
RPM

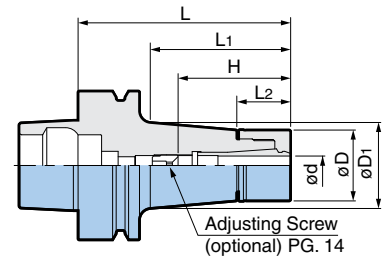

Form F (DIN V 69893-6)

Model	ød	øD	øD1	L	L1	H	Max. RPM	Collet	Weight (lbs)
HSK-F63-MEGA6E-65 ✱	.125 - .250	.984	1.106	2.56	1.34	1.54	30,000	MEC6-□	1.76
-90			1.228	3.54	2.24	1.46 - 1.77			1.98
-MEGA8E-65 ✱	.125 - .250	1.181	1.291	2.56	1.34	1.61	30,000	MEC8-□	1.76
-90			1.425	3.54	2.28	1.65 - 1.81			2.20
-MEGA10E-75 ✱	.125 - .375	1.378	1.512	2.95	1.69	1.89	30,000	MEC10-□	2.20
-90 ✱			1.618	3.54	2.28	2.64			2.64
-105			1.728	4.13	2.91	1.89 - 2.28	29,000		2.86
-120			1.838	4.72	3.54				3.52
-135			1.925	5.31	4.06				3.96
-MEGA13E-75 ✱			.125 - .500	1.654	1.799	2.95	1.81		1.97
-90 ✱	1.902	3.54			2.40	2.52	3.08		
-105	2.008	4.13			3.03	1.97 - 2.28	29,000	3.52	
-135	2.039	5.31			4.13	1.97 - 2.36	26,000	4.41	

1. Nut is included. Adjusting screw, collet and wrench must be ordered separately.
2. Adjusting screws cannot be used with models marked ✱.
3. Maximum operating speeds are directly influenced by the rigidity of the machine. Therefore, when determining the optimum cutting conditions, increase the cutting parameters gradually.
4. Weight does not include collet.

➔ For ACCESSORIES and SPARE PARTS PG. 14

Form F **KAB TOOL SHANKS**

For roughing and finish boring.

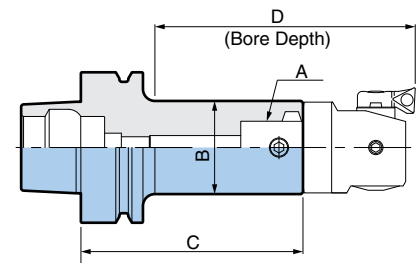

Form F (DIN V 69893-6)

Model	A	B	C	D	Weight (lbs)
HSK-F63-CK1-78	KAB1	.750	3.051	2.874	1.8
-CK2-90	KAB2	.944	3.523	3.700	1.8
-CK3-100	KAB3	1.220	3.973	4.252	2.3
-CK4-93	KAB4	1.535	3.661	4.252	2.8
-CK5-83	KAB5	1.969	3.267	4.488	3.0

1. Dimension "D" with boring head length included.

For KAB system details, please refer to catalog **NO. 308**

ACCESSORIES

■ KOMBI GRIP® for Form A, Form E & Form F

Innovative two-way clutch and needle roller clamping system assures secure clamping at the tool flange periphery. Safe design eliminates any possibility of damage to the shank taper during the tightening process.

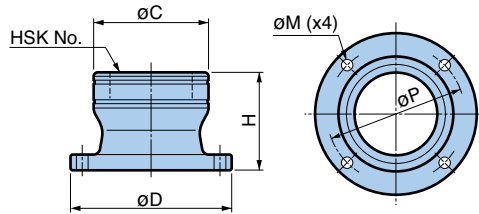

Model	HSK No.	øC	øD	H	øP	øM	
KG25R	25	1.890	3.110	2.56	2.441	.276 (for unc 1/4)	
32R	32	2.165	3.346		2.717		
40R	40	2.480	3.661	2.76	3.031		
50R	50	2.953	4.134		3.504		
63R	63	3.465	4.862	2.95	4.154		.354 (for unc 5/16)
80R	80	4.213	5.591	3.54	4.882		
100R	100	5.000	6.378	3.94	5.669		

1. Mounting bolts (4 pcs) are not included.

⚠ Caution
Kombi Grip must be securely fixed to a bench with 4 mounting bolts.

■ DYNA TEST (Test Arbor)

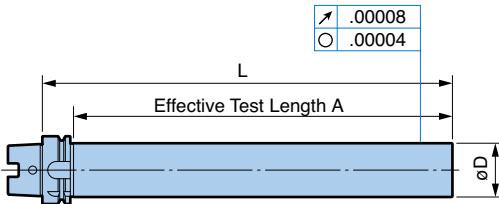

HSK Form	Model	L	A	øD
HSK-A	HSK-A40-32-L180SD	180mm (7.09")	157mm (6.18")	32mm (1.26")
	-A50-32-L240SD	240mm (9.45")	211mm (8.31")	
	-A63-50-L200SD	200mm (7.87")	171mm (6.73")	50mm (1.97")
	-L350SD	350mm (13.78")	321mm (12.64")	
	HSK-A100-50-L200SD	200mm (7.87")	168mm (6.61")	
HSK-E	-L350SD	350mm (13.78")	318mm (12.52")	20mm (.79")
	HSK-E25-20-L175	175mm (6.89")	163mm (6.42")	
	-E32-20-L180	180mm (7.09")	158mm (6.22")	32mm (1.26")
	-E40-32-L180	180mm (7.09")	157mm (6.18")	
HSK-F	-E50-32-L240	240mm (9.45")	211mm (8.31")	32mm (1.26")
	HSK-F63-50-L200	200mm (7.87")	171mm (6.73")	
	-L350	350mm (13.78")	321mm (12.64")	50mm (1.97")

Aluminum Case



An aluminum case is provided to protect and store the test bar.