

Click Change Tooling Systems

Introducing Click Change 2.0

"K" Series Negative Angle Turning Tools

Catalog 6000

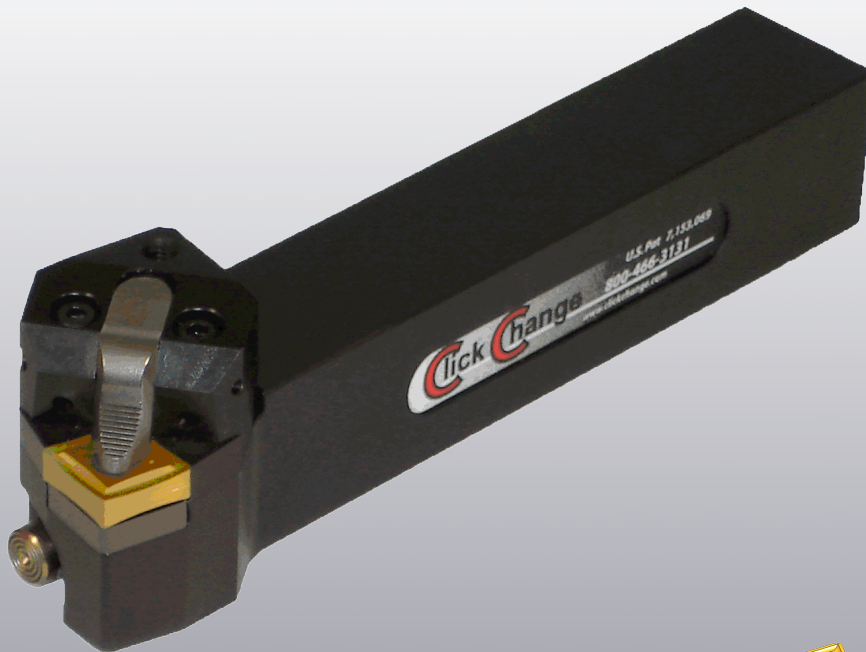

AHB Tooling & Machinery, Inc.
Complete Metalworking Solutions
Roseville Saginaw & Jackson, MI

ISO Certified
(800) 991-4225
www.ahbinc.com
customerservice@ahbinc.com

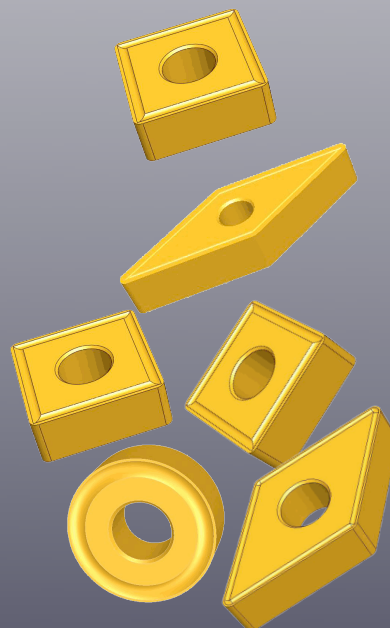

**Change Inserts
In 4 Seconds Flat
Cut Your Labor Costs
Keep Your Machines Running**

Click Change Tooling Systems

Click Change 2.0: the Latest Revolution in Toolholder Technology

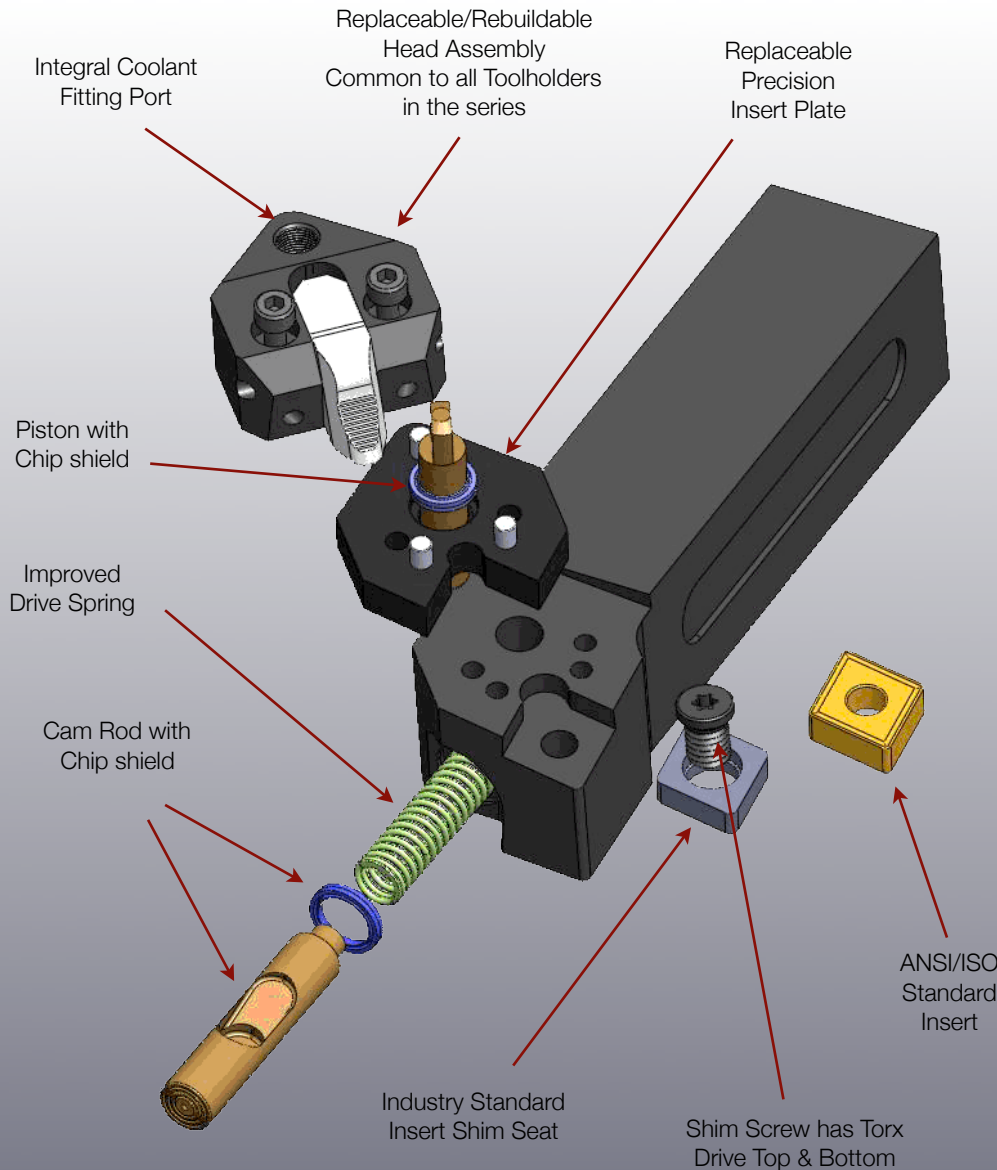

More Features

- Replaceable insert plate
- Modular construction
- Sealed mechanism
- More maintainable
- Built-in coolant

More Styles

- 100° Diamond
- 80° Diamond
- 55° Diamond
- 35° Diamond
- 90° Square
- Round

More Sizes

- Inch Sizes from: .625" - 1.500"
- Metric Sizes from: 16 mm - 32 mm

Lower Cost

- Common spare parts
- Lower maintenance
- Lower initial cost
- Longer lifetime

4 Second Insert Changes, Payback in Days !

Click Change Lathe Turning Tool Catalog

U.S. Patent 7153069 other US & foreign patents



80° Diamond 1/2" I.C. Insert

For: CNGA, CNGN, CNGP, CNMA, CNMG, CNMM, CNMN, & CNMP
All tools have a replaceable rear insert wall, and built-in coolant.

80° Profile
40° Lead
KCMNN
See Page 7

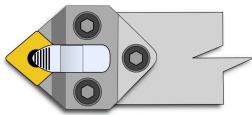

Inch Sizes (L/R)
0.625" 4", 4.5"
0.750" 4", 4.5", 5"
1.000" 4", 4.5", 5", 6"
1.250" 6"
1.500" 6"
Metric Sizes (L/R)
16 mm 100, 125
20 mm 125, 150
25 mm 125, 150
32 mm 170

80° Turn/Face
-5° Lead
KCLNR/L
See Page 8

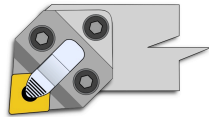

Inch Sizes
0.625" 4", 4.5"
0.750" 4", 4.5", 5"
1.000" 4", 4.5", 5", 6"
1.250" 6"
1.500" 6"
Metric Sizes
16 mm 100, 125
20 mm 125, 150
25 mm 125, 150
32 mm 170

100° Turn
15° Lead
KCRNR/L
See Page 9

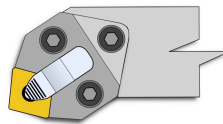

Inch Sizes (L/R)
0.625" 4", 4.5"
0.750" 4", 4.5", 5"
1.000" 4", 4.5", 5", 6"
1.250" 6"
1.500" 6"
Metric Sizes (L/R)
16 mm 100, 125
20 mm 125, 150
25 mm 125, 150
32 mm 170

100° Face
15° Lead
KCKNR/L
See Page 10

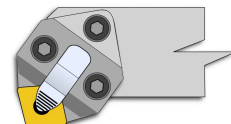

Inch Sizes (L/R)
0.625" 4", 4.5"
0.750" 4", 4.5", 5"
1.000" 4", 4.5", 5", 6"
1.250" 6"
1.500" 6"
Metric Sizes (L/R)
16 mm 100, 125
20 mm 125, 150
25 mm 125, 150
32 mm 170



55° Diamond 1/2" I.C. Insert

For: DNGA, DNGM, DNGN, DNGP, DNMA, DNMG, DNMM, DNMN, & DNMP
All tools have a replaceable rear insert wall, and built-in coolant.

55° Profile
27.5° Lead
KDPNN
See Page 11

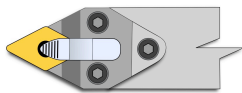

Inch Sizes (L/R)
0.625" 4", 4.5"
0.750" 4", 4.5", 5"
1.000" 4", 4.5", 5", 6"
1.250" 6"
1.500" 6"
Metric Sizes (L/R)
16 mm 100, 125
20 mm 125, 150
25 mm 125, 150
32 mm 170

55° Turn
-3° Lead
KDJNR/L
See Page 12

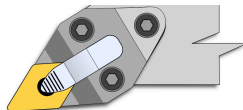

Inch Sizes
0.625" 4", 4.5"
0.750" 4", 4.5", 5"
1.000" 4", 4.5", 5", 6"
1.250" 6"
1.500" 6"
Metric Sizes
16 mm 100, 125
20 mm 125, 150
25 mm 125, 150
32 mm 170

55° Turn/Face
-17.5° Lead
KDQNR/L
See Page 13

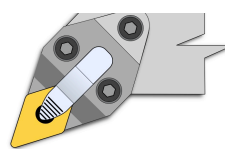

Inch Sizes (L/R)
0.625" 4", 4.5"
0.750" 4", 4.5", 5"
1.000" 4", 4.5", 5", 6"
1.250" 6"
1.500" 6"
Metric Sizes (L/R)
16 mm 100, 125
20 mm 125, 150
25 mm 125, 150
32 mm 170

55° Face
-32° Lead
KDUNR/L
See Page 14

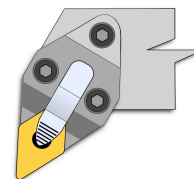

Inch Sizes (L/R)
0.625" 4", 4.5"
0.750" 4", 4.5", 5"
1.000" 4", 4.5", 5", 6"
1.250" 6"
1.500" 6"
Metric Sizes (L/R)
16 mm 100, 125
20 mm 125, 150
25 mm 125, 150
32 mm 170



35° Diamond 3/8" I.C. Insert

For: VNGA, VNGM, VNGP, VNMA, VNMG, VNMN, & VNMP
All tools have a replaceable rear insert wall, and built-in coolant.

35° Profile
17.5° Lead
KVVNN
See Page 15

35° Turn/Profile
-3° Lead
KVJNR/L
See Page 16

35° Turn/Face
15° Lead
KVQNR/L
See Page 17

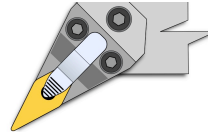
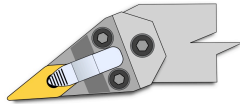
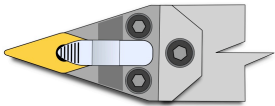

Inch Sizes (L/R)
0.625" 4", 4.5"
0.750" 4", 4.5", 5"
1.000" 4", 4.5", 5", 6"
1.250" 6"
1.500" 6"
Metric Sizes (L/R)
16 mm 100,125
20 mm 125,150
25 mm 125,150
32 mm 170

Inch Sizes
0.625" 4", 4.5"
0.750" 4", 4.5", 5"
1.000" 4", 4.5", 5", 6"
1.250" 6"
1.500" 6"
Metric Sizes
16 mm 100,125
20 mm 125,150
25 mm 125,150
32 mm 170

Inch Sizes (L/R)
0.625" 4", 4.5"
0.750" 4", 4.5", 5"
1.000" 4", 4.5", 5", 6"
1.250" 6"
1.500" 6"
Metric Sizes (L/R)
16 mm 100,125
20 mm 125,150
25 mm 125,150
32 mm 170



90° Square 1/2" I.C. Insert

For: SNG, SNGA, SNGN, SNMA, SNMG, SNMM, SNMN, SNMP, & SNU
All tools have a replaceable rear insert wall, and built-in coolant.

90° Profile
45° Lead
KSDNN
See Page 18

90° Turn/Face
15° Lead
KSRNR/L
See Page 19

90° Turn
15° Lead
KSKNR/L
See Page 20

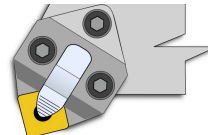
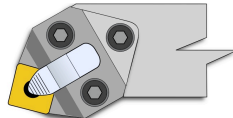
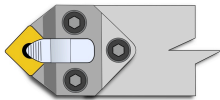

Inch Sizes (L/R)
0.625" 4", 4.5"
0.750" 4", 4.5", 5"
1.000" 4", 4.5", 5", 6"
1.250" 6"
1.500" 6"
Metric Sizes (L/R)
16 mm 100,125
20 mm 125,150
25 mm 125,150
32 mm 170

Inch Sizes
0.625" 4", 4.5"
0.750" 4", 4.5", 5"
1.000" 4", 4.5", 5", 6"
1.250" 6"
1.500" 6"
Metric Sizes
16 mm 100,125
20 mm 125,150
25 mm 125,150
32 mm 170

Inch Sizes (L/R)
0.625" 4", 4.5"
0.750" 4", 4.5", 5"
1.000" 4", 4.5", 5", 6"
1.250" 6"
1.500" 6"
Metric Sizes (L/R)
16 mm 100,125
20 mm 125,150
25 mm 125,150
32 mm 170



Round 1/2" I.C. Insert

For: RNGN, RNMA, RNMG, & RNMN

All tools have a replaceable rear insert wall, and built-in coolant.

Turn/Face

KRGNR/L

See Page 20

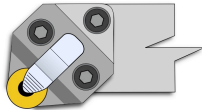

Inch Sizes (L/R)

0.625" 4", 4.5"
 0.750" 4", 4.5", 5"
 1.000" 4", 4.5", 5", 6"
 1.250" 6"
 1.500" 6"

Metric Sizes (L/R)

16 mm 100,125
 20 mm 125,150
 25 mm 125,150
 32 mm 170

Inch Sizes

0.625" 4", 4.5"
 0.750" 4", 4.5", 5"
 1.000" 4", 4.5", 5", 6"
 1.250" 6"
 1.500" 6"

Metric Sizes

16 mm 100,125
 20 mm 125,150
 25 mm 125,150
 32 mm 170

Inch Sizes (L/R)

0.625" 4", 4.5"
 0.750" 4", 4.5", 5"
 1.000" 4", 4.5", 5", 6"
 1.250" 6"
 1.500" 6"

Metric Sizes (L/R)

16 mm 100,125
 20 mm 125,150
 25 mm 125,150
 32 mm 170

Inch Sizes (L/R)

0.625" 4", 4.5"
 0.750" 4", 4.5", 5"
 1.000" 4", 4.5", 5", 6"
 1.250" 6"
 1.500" 6"

Metric Sizes (L/R)

16 mm 100,125
 20 mm 125,150
 25 mm 125,150
 32 mm 170

KCMNN

For use with: CNGA, CNGN, CNGP, CNMA, CNMG, CNMM, CNMN, & CNMP Inserts

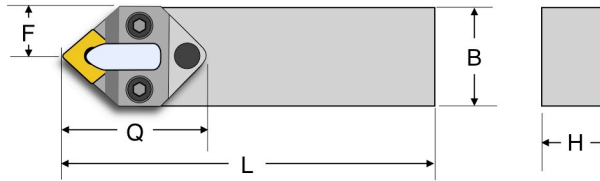
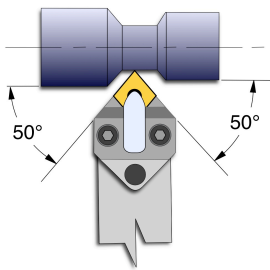

Gage insert is a CNMG-432
Insert height same as shank "H"

Front Side Rake 5.0° Back Side Rake 5.0°
Compound insert angle is 7.75°
measured along the insert centerline

Available Sizes

Catalog Number	Dimensions					Components		
	H	L	B	F	Q	Piston	Shim	Seal
KCMNN-104A	.625"	4.00"	1.13"	.565"	1.72"	PS-6000-079	none	none
KCMNN-104B	.625"	4.50"	1.13"	.565"	1.72"	PS-6000-079	none	none
KCMNN-124A	.750"	4.00"	1.13"	.565"	1.72"	PS-6000-090	none	none
KCMNN-124B	.750"	4.50"	1.13"	.565"	1.72"	PS-6000-090	none	none
KCMNN-124C	.750"	5.00"	1.13"	.565"	1.72"	PS-6000-090	none	none
KCMNN-164A	1.00"	4.00"	1.13"	.565"	1.72"	PS-6000-110	ICSN-432	VS-3125
KCMNN-164B	1.00"	4.50"	1.13"	.565"	1.72"	PS-6000-110	ICSN-432	VS-3125
KCMNN-164C	1.00"	5.00"	1.13"	.565"	1.72"	PS-6000-110	ICSN-432	VS-3125
KCMNN-164D	1.00"	6.00"	1.13"	.565"	1.72"	PS-6000-110	ICSN-432	VS-3125
KCMNN-204D	1.25"	6.00"	1.25"	.625"	1.72"	PS-6000-136	ICSN-432	VS-3125
KCMNN-244D	1.50"	6.00"	1.50"	.750"	1.72"	PS-6000-136	ICSN-432	VS-3125
KCMNN-1625H-12	16 mm	100 mm	29 mm	14.3 mm	44 mm	PS-6000-079	none	none
KCMNN-1625K-12	16 mm	125 mm	29 mm	14.3 mm	44 mm	PS-6000-079	none	none
KCMNN-2025K-12	20 mm	125 mm	29 mm	14.3 mm	44 mm	PS-6000-090	none	VS-3125
KCMNN-2025M-12	20 mm	150 mm	29 mm	14.3 mm	44 mm	PS-6000-090	none	VS-3125
KCMNN-2525K-12	25 mm	125 mm	29 mm	14.3 mm	44 mm	PS-6000-110	ICSN-432	VS-3125
KCMNN-2525M-12	25 mm	150 mm	29 mm	14.3 mm	44 mm	PS-6000-110	ICSN-432	VS-3125
KCMNN-3225P-12	32 mm	170 mm	29 mm	14.3 mm	44 mm	PS-6000-136	ICSN-432	VS-3125

Spare Parts

Shim Seat	Shim Screw	Insert Plate	Clamp Head	Piston	Cam Rod	Drive Spring	Front Seal
ICSN-432	SR-6000	IP-6001	HA-6001	see above	CR-6001	DS-1008	VS-3125

Clamp Head Spare Parts

Head Body	Clamp Lever	Axle Pin	Spring Pins	Cl Springs	Set Screws	Cap Screws
CV-6001	CL-6001	HDPM-2.5x20	SP-6000	CS-6000	HSSM-3x3	HCSM-3x20

Click Change Lathe Turning Toolholders

U.S. Patent 7153069 other US & foreign patents pending

KCLNR/L For use with: CNGA, CNGN, CNGP, CNMA, CNMG, CNMM, CNMN, & CNMP Inserts

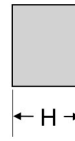
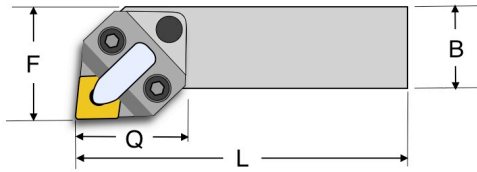
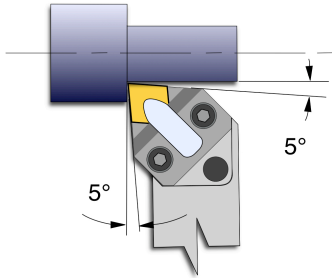

Right Hand Toolholder Shown
Gage insert is a CNMG-432
Insert height same as shank "H"

Front Side Rake 5.0° Back Side Rake 5.0°
Compound insert angle is 7.75°
measured along the insert centerline

Available Sizes

Catalog Number		Dimensions					Components		
Right Hand	Left Hand	H	L	B	F	Q	Piston	Shim	Seal
KCLNR-104A	KCLNL-104A	.625"	4.00"	1.00"	1.25"	1.26"	PS-6000-079	ICSN-432	none
KCLNR-104B	KCLNL-104B	.625"	4.50"	1.00"	1.25"	1.26"	PS-6000-079	ICSN-432	none
KCLNR-124A	KCLNL-124A	.750"	4.00"	1.00"	1.25"	1.26"	PS-6000-090	ICSN-432	VS-3125
KCLNR-124B	KCLNL-124B	.750"	4.50"	1.00"	1.25"	1.26"	PS-6000-090	ICSN-432	VS-3125
KCLNR-124C	KCLNL-124C	.750"	5.00"	1.00"	1.25"	1.26"	PS-6000-090	ICSN-432	VS-3125
KCLNR-164A	KCLNL-164A	1.00"	4.00"	1.00"	1.25"	1.26"	PS-6000-110	ICSN-432	VS-3125
KCLNR-164B	KCLNL-164B	1.00"	4.50"	1.00"	1.25"	1.26"	PS-6000-110	ICSN-432	VS-3125
KCLNR-164C	KCLNL-164C	1.00"	5.00"	1.00"	1.25"	1.26"	PS-6000-110	ICSN-432	VS-3125
KCLNR-164D	KCLNL-164D	1.00"	6.00"	1.00"	1.25"	1.26"	PS-6000-110	ICSN-432	VS-3125
KCLNR-204D	KCLNL-204D	1.25"	6.00"	1.25"	1.50"	1.26"	PS-6000-136	ICSN-432	VS-3125
KCLNR-244D	KCLNL-244D	1.50"	6.00"	1.50"	1.75"	1.26"	PS-6000-136	ICSN-432	VS-3125
KCLNR-1625H-12	KCLNL-1625H-12	16 mm	100 mm	25 mm	20 mm	32 mm	PS-6000-079	ICSN-432	none
KCLNR-1625K-12	KCLNL-1625K-12	16 mm	125 mm	25 mm	20 mm	32 mm	PS-6000-079	ICSN-432	none
KCLNR-2025K-12	KCLNL-2025K-12	20 mm	125 mm	25 mm	20 mm	32 mm	PS-6000-090	ICSN-432	VS-3125
KCLNR-2025M-12	KCLNL-2025M-12	20 mm	150 mm	25 mm	20 mm	32 mm	PS-6000-090	ICSN-432	VS-3125
KCLNR-2525K-12	KCLNL-2525K-12	25 mm	125 mm	25 mm	25 mm	32 mm	PS-6000-110	ICSN-432	VS-3125
KCLNR-2525M-12	KCLNL-2525M-12	25 mm	150 mm	25 mm	25 mm	32 mm	PS-6000-110	ICSN-432	VS-3125
KCLNR-3225P-12	KCLNL-3225P-12	32 mm	170 mm	25 mm	32 mm	32 mm	PS-6000-136	ICSN-432	VS-3125

Spare Parts

Shim Seat	Shim Screw	Insert Plate	Clamp Head	Piston	Cam Rod	Drive Spring	Front Seal
ICSN-432	SR-6000	IP-6001	HA-6001	see above	CR-6001	DS-1008	VS-3125

Clamp Head Spare Parts

Head Body	Clamp Lever	Axle Pin	Spring Pins	Cl Springs	Set Screws	Cap Screws
CV-6001	CL-6001	HDPM-2.5x20	SP-6000	CS-6000	HSSM-3x3	HCSM-3x20

Click Change Lathe Turning Toolholders

U.S. Patent 7153069 other US & foreign patents pending

KCRNR/L For use with: CNGA, CNGN, CNGP, CNMA, CNMG, CNMM, CNMN, & CNMP Inserts

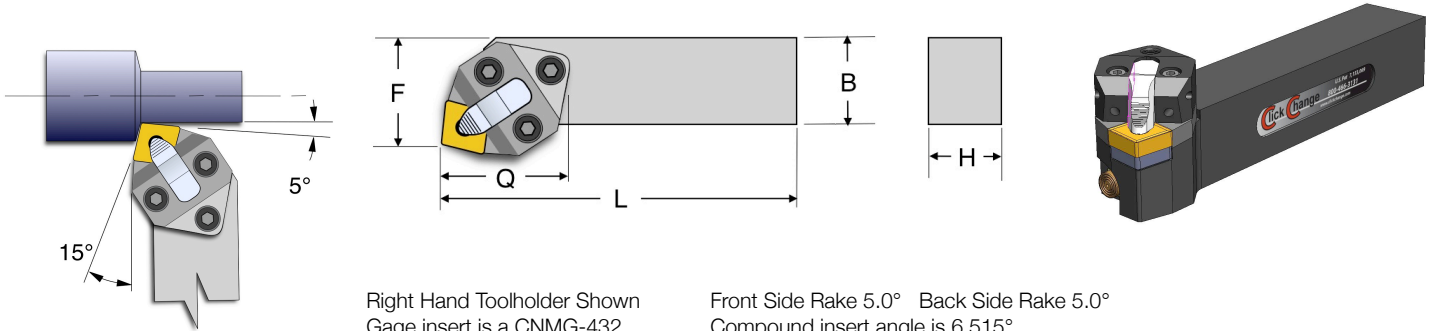

Right Hand Toolholder Shown
Gage insert is a CNMG-432
Insert height same as shank "H"

Front Side Rake 5.0° Back Side Rake 5.0°
Compound insert angle is 6.515°
measured along the insert centerline

Available Sizes

Catalog Number		Dimensions					Components		
Right Hand	Left Hand	H	L	B	F	Q	Piston	Shim	Seal
KCRNR-104A	KCRNL-104A	.625"	4.00"	1.00"	1.15"	1.40"	PS-6000-079	ICSN-432	none
KCRNR-104B	KCRNL-104B	.625"	4.50"	1.00"	1.15"	1.40"	PS-6000-079	ICSN-432	none
KCRNR-124A	KCRNL-124A	.750"	4.00"	1.00"	1.15"	1.40"	PS-6000-090	ICSN-432	none
KCRNR-124B	KCRNL-124B	.750"	4.50"	1.00"	1.15"	1.40"	PS-6000-090	ICSN-432	none
KCRNR-124C	KCRNL-124C	.750"	5.00"	1.00"	1.15"	1.40"	PS-6000-090	ICSN-432	none
KCRNR-164A	KCRNL-164A	1.00"	4.00"	1.00"	1.15"	1.40"	PS-6000-110	ICSN-432	VS-3125
KCRNR-164B	KCRNL-164B	1.00"	4.50"	1.00"	1.15"	1.40"	PS-6000-110	ICSN-432	VS-3125
KCRNR-164C	KCRNL-164C	1.00"	5.00"	1.00"	1.15"	1.40"	PS-6000-110	ICSN-432	VS-3125
KCRNR-164D	KCRNL-164D	1.00"	6.00"	1.00"	1.15"	1.40"	PS-6000-110	ICSN-432	VS-3125
KCRNR-204D	KCRNL-204D	1.25"	6.00"	1.25"	1.30"	1.40"	PS-6000-136	ICSN-432	VS-3125
KCRNR-244D	KCRNL-244D	1.50"	6.00"	1.50"	1.55"	1.40"	PS-6000-136	ICSN-432	VS-3125
KCRNR-1625H-12	KCRNL-1625H-12	16 mm	100 mm	25 mm	29 mm	36 mm	PS-6000-079	ICSN-432	none
KCRNR-1625K-12	KCRNL-1625K-12	16 mm	125 mm	25 mm	29 mm	36 mm	PS-6000-079	ICSN-432	none
KCRNR-2025K-12	KCRNL-2025K-12	20 mm	125 mm	25 mm	29 mm	36 mm	PS-6000-090	ICSN-432	VS-3125
KCRNR-2025M-12	KCRNL-2025M-12	20 mm	150 mm	25 mm	29 mm	36 mm	PS-6000-090	ICSN-432	VS-3125
KCRNR-2525K-12	KCRNL-2525K-12	25 mm	125 mm	25 mm	29 mm	36 mm	PS-6000-110	ICSN-432	VS-3125
KCRNR-2525M-12	KCRNL-2525M-12	25 mm	150 mm	25 mm	29 mm	36 mm	PS-6000-110	ICSN-432	VS-3125
KCRNR-3225P-12	KCRNL-3225P-12	32 mm	170 mm	25 mm	29 mm	36 mm	PS-6000-136	ICSN-432	VS-3125

Spare Parts

Shim Seat	Shim Screw	Insert Plate	Clamp Head	Piston	Cam Rod	Drive Spring	Front Seal
ICSN-432	SR-6000	IP-6006	HA-6001	see above	CR-6001	DS-1008	VS-3125

Clamp Head Spare Parts

Head Body	Clamp Lever	Axle Pin	Spring Pins	Cl Springs	Set Screws	Cap Screws
CV-6001	CL-6001	HDPM-2.5x20	SP-6000	CS-6000	HSSM-3x3	HCSM-3x20

Click Change Lathe Turning Toolholders

U.S. Patent 7153069 other US & foreign patents pending

KCKNR/L For use with: CNGA, CNGN, CNGP, CNMA, CNMG, CNMM, CNMN, & CNMP Inserts

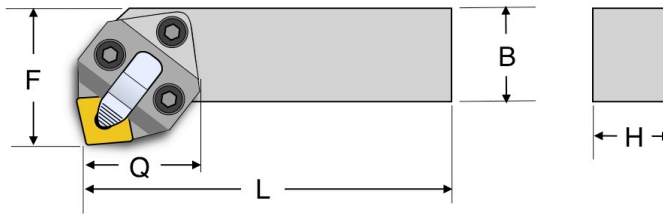
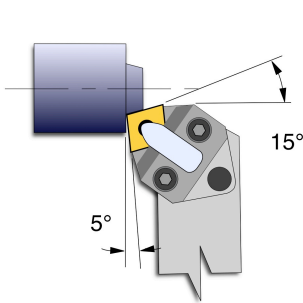

Right Hand Toolholder Shown
Gage insert is a CNMG-432
Insert height same as shank "H"

Front Side Rake 5.0° Back Side Rake 5.0°
Compound insert angle is 6.515°
measured along the insert centerline

Available Sizes

Catalog Number		Dimensions					Components		
Right Hand	Left Hand	H	L	B	F	Q	Piston	Shim	Seal
KCKNR-104A	KCKNL-104A	.625"	4.00"	1.00"	1.42"	1.25"	PS-6000-079	ICSN-432	none
KCKNR-104B	KCKNL-104B	.625"	4.50"	1.00"	1.42"	1.25"	PS-6000-079	ICSN-432	none
KCKNR-124A	KCKNL-124A	.750"	4.00"	1.00"	1.42"	1.25"	PS-6000-090	ICSN-432	none
KCKNR-124B	KCKNL-124B	.750"	4.50"	1.00"	1.42"	1.25"	PS-6000-090	ICSN-432	none
KCKNR-124C	KCKNL-124C	.750"	5.00"	1.00"	1.42"	1.25"	PS-6000-090	ICSN-432	none
KCKNR-164A	KCKNL-164A	1.00"	4.00"	1.00"	1.42"	1.25"	PS-6000-110	ICSN-432	VS-3125
KCKNR-164B	KCKNL-164B	1.00"	4.50"	1.00"	1.42"	1.25"	PS-6000-110	ICSN-432	VS-3125
KCKNR-164C	KCKNL-164C	1.00"	5.00"	1.00"	1.42"	1.25"	PS-6000-110	ICSN-432	VS-3125
KCKNR-164D	KCKNL-164D	1.00"	6.00"	1.00"	1.42"	1.25"	PS-6000-110	ICSN-432	VS-3125
KCKNR-204D	KCKNL-204D	1.25"	6.00"	1.25"	1.54"	1.25"	PS-6000-136	ICSN-432	VS-3125
KCKNR-244D	KCKNL-244D	1.50"	6.00"	1.50"	1.79"	1.25"	PS-6000-136	ICSN-432	VS-3125
KCKNR-1625H-12	KCKNL-1625H-12	16 mm	100 mm	25 mm	36 mm	32 mm	PS-6000-079	ICSN-432	none
KCKNR-1625K-12	KCKNL-1625K-12	16 mm	125 mm	25 mm	36 mm	32 mm	PS-6000-079	ICSN-432	none
KCKNR-2025K-12	KCKNL-2025K-12	20 mm	125 mm	25 mm	36 mm	32 mm	PS-6000-090	ICSN-432	VS-3125
KCKNR-2025M-12	KCKNL-2025M-12	20 mm	150 mm	25 mm	36 mm	32 mm	PS-6000-090	ICSN-432	VS-3125
KCKNR-2525K-12	KCKNL-2525K-12	25 mm	125 mm	25 mm	36 mm	32 mm	PS-6000-110	ICSN-432	VS-3125
KCKNR-2525M-12	KCKNL-2525M-12	25 mm	150 mm	25 mm	36 mm	32 mm	PS-6000-110	ICSN-432	VS-3125
KCKNR-3225P-12	KCKNL-3225P-12	32 mm	170 mm	25 mm	36 mm	32 mm	PS-6000-136	ICSN-432	VS-3125

Spare Parts

Shim Seat	Shim Screw	Insert Plate	Clamp Head	Piston	Cam Rod	Drive Spring	Front Seal
ICSN-432	SR-6000	IP-6006	HA-6001	see above	CR-6001	DS-1008	VS-3125

Clamp Head Spare Parts

Head Body	Clamp Lever	Axle Pin	Spring Pins	Cl Springs	Set Screws	Cap Screws
CV-6001	CL-6001	HDPM-2.5x20	SP-6000	CS-6000	HSSM-3x3	HCSM-3x20

Click Change Lathe Turning Toolholders

U.S. Patent 7153069 other US & foreign patents pending

KDPNN For use with: DNGA, DNGM, DNGN, DNGP, DNMA, DNMG, DNMM, DNMM, & DNMP inserts

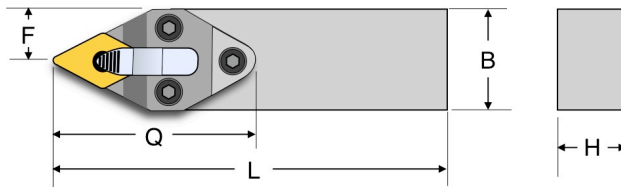
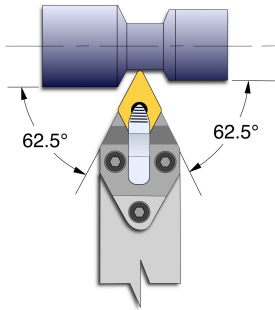

Gage insert is a DNMG-432
Insert height same as shank "H"

Front Side Rake 5.0° Back Side Rake 5.0°
Compound insert angle is 10.73°
measured along the insert centerline

Available Sizes

Catalog Number	Dimensions					Components		
	H	L	B	F	Q	Piston	Shim	Seal
KDPNN-104A	.625"	4.00"	1.13"	.565"	2.09"	PS-6000-087	none	none
KDPNN-104B	.625"	4.50"	1.13"	.565"	2.09"	PS-6000-087	none	none
KDPNN-124A	.750"	4.00"	1.13"	.565"	2.09"	PS-6000-097	none	none
KDPNN-124B	.750"	4.50"	1.13"	.565"	2.09"	PS-6000-097	none	none
KDPNN-124C	.750"	5.00"	1.13"	.565"	2.09"	PS-6000-097	none	none
KDPNN-164A	1.00"	4.00"	1.13"	.565"	2.09"	PS-6000-119	IDSN-432	VS-3125
KDPNN-164B	1.00"	4.50"	1.13"	.565"	2.09"	PS-6000-119	IDSN-432	VS-3125
KDPNN-164C	1.00"	5.00"	1.13"	.565"	2.09"	PS-6000-119	IDSN-432	VS-3125
KDPNN-164D	1.00"	6.00"	1.13"	.565"	2.09"	PS-6000-119	IDSN-432	VS-3125
KDPNN-204D	1.25"	6.00"	1.25"	.625"	2.09"	PS-6000-144	IDSN-432	VS-3125
KDPNN-244D	1.50"	6.00"	1.50"	.750"	2.09"	PS-6000-144	IDSN-432	VS-3125
KDPNN-1625H-15	16 mm	100 mm	29 mm	14.3 mm	53 mm	PS-6000-087	none	none
KDPNN-1625K-15	16 mm	125 mm	29 mm	14.3 mm	53 mm	PS-6000-087	none	none
KDPNN-2025K-15	20 mm	125 mm	29 mm	14.3 mm	53 mm	PS-6000-097	none	VS-3125
KDPNN-2025M-15	20 mm	150 mm	29 mm	14.3 mm	53 mm	PS-6000-097	none	VS-3125
KDPNN-2525K-15	25 mm	125 mm	29 mm	14.3 mm	53 mm	PS-6000-119	IDSN-432	VS-3125
KDPNN-2525M-15	25 mm	150 mm	29 mm	14.3 mm	53 mm	PS-6000-119	IDSN-432	VS-3125
KDPNN-3225P-15	32 mm	170 mm	29 mm	14.3 mm	53 mm	PS-6000-144	IDSN-432	VS-3125

Spare Parts

Shim Seat	Shim Screw	Insert Plate	Clamp Head	Piston	Cam Rod	Drive Spring	Front Seal
IDSN-432	SR-6000	IP-6041	HA-6040	see above	CR-6001	DS-1008	VS-3125

Clamp Head Spare Parts

Head Body	Clamp Lever	Axle Pin	Spring Pins	Cl Springs	Set Screws	Cap Screws
CV-6040	CL-6041	HDPM-2.5x20	SP-6000	CS-6000	HSSM-3x3	HCSM-3x20

Click Change Lathe Turning Toolholders

U.S. Patent 7153069 other US & foreign patents pending

KDJNR/L For use with: DNGA, DNGM, DNGN, DNGP, DNMA, DNMG, DNMM, DNMM, & DNMP inserts

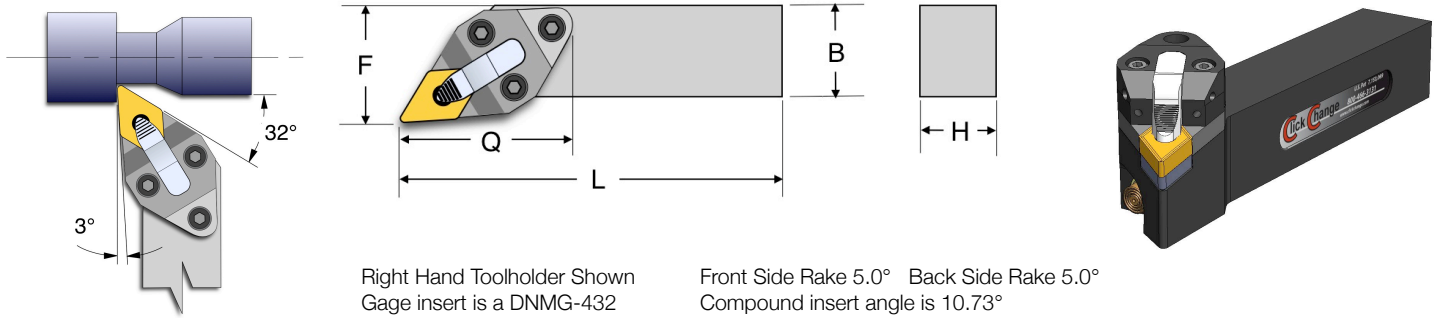

Available Sizes

Catalog Number		Dimensions					Components		
Right Hand	Left Hand	H	L	B	F	Q	Piston	Shim	Seal
KDJNR-104A	KDJNL-104A	.625"	4.00"	1.00"	1.25"	1.85"	PS-6000-087	ICSN-432	VS-3125
KDJNR-104B	KDJNL-104B	.625"	4.50"	1.00"	1.25"	1.85"	PS-6000-087	ICSN-432	VS-3125
KDJNR-124A	KDJNL-124A	.750"	4.00"	1.00"	1.25"	1.85"	PS-6000-097	ICSN-432	VS-3125
KDJNR-124B	KDJNL-124B	.750"	4.50"	1.00"	1.25"	1.85"	PS-6000-097	ICSN-432	VS-3125
KDJNR-124C	KDJNL-124C	.750"	5.00"	1.00"	1.25"	1.85"	PS-6000-097	ICSN-432	VS-3125
KDJNR-164A	KDJNL-164A	1.00"	4.00"	1.00"	1.25"	1.85"	PS-6000-119	ICSN-432	VS-3125
KDJNR-164B	KDJNL-164B	1.00"	4.50"	1.00"	1.25"	1.85"	PS-6000-119	ICSN-432	VS-3125
KDJNR-164C	KDJNL-164C	1.00"	5.00"	1.00"	1.25"	1.85"	PS-6000-119	ICSN-432	VS-3125
KDJNR-164D	KDJNL-164D	1.00"	6.00"	1.00"	1.25"	1.85"	PS-6000-119	ICSN-432	VS-3125
KDJNR-204D	KDJNL-204D	1.25"	6.00"	1.25"	1.50"	1.85"	PS-6000-144	ICSN-432	VS-3125
KDJNR-244D	KDJNL-244D	1.50"	6.00"	1.50"	1.75"	1.85"	PS-6000-144	ICSN-432	VS-3125
KDJNR-1625H-15	KDJNL-1625H-15	16 mm	100 mm	25 mm	32 mm	47 mm	PS-6000-087	ICSN-432	VS-3125
KDJNR-1625K-15	KDJNL-1625K-15	16 mm	125 mm	25 mm	32 mm	47 mm	PS-6000-087	ICSN-432	VS-3125
KDJNR-2025K-15	KDJNL-2025K-15	20 mm	125 mm	25 mm	32 mm	47 mm	PS-6000-097	ICSN-432	VS-3125
KDJNR-2025M-15	KDJNL-2025M-15	20 mm	150 mm	25 mm	32 mm	47 mm	PS-6000-097	ICSN-432	VS-3125
KDJNR-2525K-15	KDJNL-2525K-15	25 mm	125 mm	25 mm	32 mm	47 mm	PS-6000-119	ICSN-432	VS-3125
KDJNR-2525M-15	KDJNL-2525M-15	25 mm	150 mm	25 mm	32 mm	47 mm	PS-6000-119	ICSN-432	VS-3125
KDJNR-3225P-15	KDJNL-3225P-15	32 mm	170 mm	25 mm	32 mm	47 mm	PS-6000-144	ICSN-432	VS-3125

Spare Parts

Shim Seat	Shim Screw	Insert Plate	Clamp Head	Piston	Cam Rod	Drive Spring	Front Seal
IDSN-432	SR-6000	IP-6041	HA-6040	see above	CR-6001	DS-1008	VS-3125

Clamp Head Spare Parts

Head Body	Clamp Lever	Axle Pin	Spring Pins	Cl. Springs	Set Screws	Cap Screws
CV-6040	CL-6041	HDPM-2.5x20	SP-6000	CS-6000	HSSM-3x3	HCSM-3x20

Click Change Lathe Turning Toolholders

U.S. Patent 7153069 other US & foreign patents pending

KDQNR/L For use with: DNGA, DNGM, DNGN, DNGP, DNMA, DNMG, DNMM, DNMP, & DNMP inserts

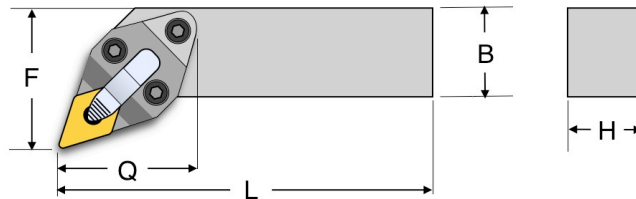
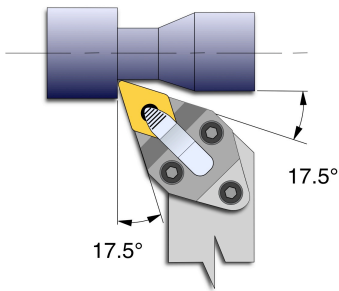

Right Hand Toolholder Shown
Gage insert is a DNMG-432
Insert height same as shank "H"

Front Side Rake 5.0° Back Side Rake 5.0°
Compound insert angle is 10.73°
measured along the insert centerline

Available Sizes

Catalog Number		Dimensions					Components		
Right Hand	Left Hand	H	L	B	F	Q	Piston	Shim	Seal
KDQNR-104A	KDQNL-104A	.625"	4.00"	1.00"	1.60"	1.57"	PS-6000-087	ICSN-432	none
KDQNR-104B	KDQNL-104B	.625"	4.50"	1.00"	1.60"	1.57"	PS-6000-087	ICSN-432	none
KDQNR-124A	KDQNL-124A	.750"	4.00"	1.00"	1.60"	1.57"	PS-6000-097	ICSN-432	VS-3125
KDQNR-124B	KDQNL-124B	.750"	4.50"	1.00"	1.60"	1.57"	PS-6000-097	ICSN-432	VS-3125
KDQNR-124C	KDQNL-124C	.750"	5.00"	1.00"	1.60"	1.57"	PS-6000-097	ICSN-432	VS-3125
KDQNR-164A	KDQNL-164A	1.00"	4.00"	1.00"	1.60"	1.57"	PS-6000-119	ICSN-432	VS-3125
KDQNR-164B	KDQNL-164B	1.00"	4.50"	1.00"	1.60"	1.57"	PS-6000-119	ICSN-432	VS-3125
KDQNR-164C	KDQNL-164C	1.00"	5.00"	1.00"	1.60"	1.57"	PS-6000-119	ICSN-432	VS-3125
KDQNR-164D	KDQNL-164D	1.00"	6.00"	1.00"	1.60"	1.57"	PS-6000-119	ICSN-432	VS-3125
KDQNR-204D	KDQNL-204D	1.25"	6.00"	1.25"	1.80"	1.57"	PS-6000-144	ICSN-432	VS-3125
KDQNR-244D	KDQNL-244D	1.50"	6.00"	1.50"	2.05"	1.57"	PS-6000-144	ICSN-432	VS-3125
KDQNR-1625H-15	KDQNL-1625H-15	16 mm	100 mm	25 mm	41 mm	40 mm	PS-6000-087	ICSN-432	none
KDQNR-1625K-15	KDQNL-1625K-15	16 mm	125 mm	25 mm	41 mm	40 mm	PS-6000-087	ICSN-432	none
KDQNR-2025K-15	KDQNL-2025K-15	20 mm	125 mm	25 mm	41 mm	40 mm	PS-6000-097	ICSN-432	VS-3125
KDQNR-2025M-15	KDQNL-2025M-15	20 mm	150 mm	25 mm	41 mm	40 mm	PS-6000-097	ICSN-432	VS-3125
KDQNR-2525K-15	KDQNL-2525K-15	25 mm	125 mm	25 mm	41 mm	40 mm	PS-6000-119	ICSN-432	VS-3125
KDQNR-2525M-15	KDQNL-2525M-15	25 mm	150 mm	25 mm	41 mm	40 mm	PS-6000-119	ICSN-432	VS-3125
KDQNR-3225P-15	KDQNL-3225P-15	32 mm	170 mm	25 mm	41 mm	40 mm	PS-6000-144	ICSN-432	VS-3125

Spare Parts

Shim Seat	Shim Screw	Insert Plate	Clamp Head	Piston	Cam Rod	Drive Spring	Front Seal
IDSN-432	SR-6000	IP-6041	HA-6040	see above	CR-6001	DS-1008	VS-3125

Clamp Head Spare Parts

Head Body	Clamp Lever	Axle Pin	Spring Pins	Cl Springs	Set Screws	Cap Screws
CV-6040	CL-6041	HDCM-2.5x20	SP-6000	CS-6000	HSSM-3x3	HCSM-3x20

Click Change Lathe Turning Toolholders

U.S. Patent 7153069 other US & foreign patents pending

KDUNR/L For use with: DNGA, DNGM, DNGN, DNGP, DNMA, DNMG, DNMM, DNMN, & DNMP inserts

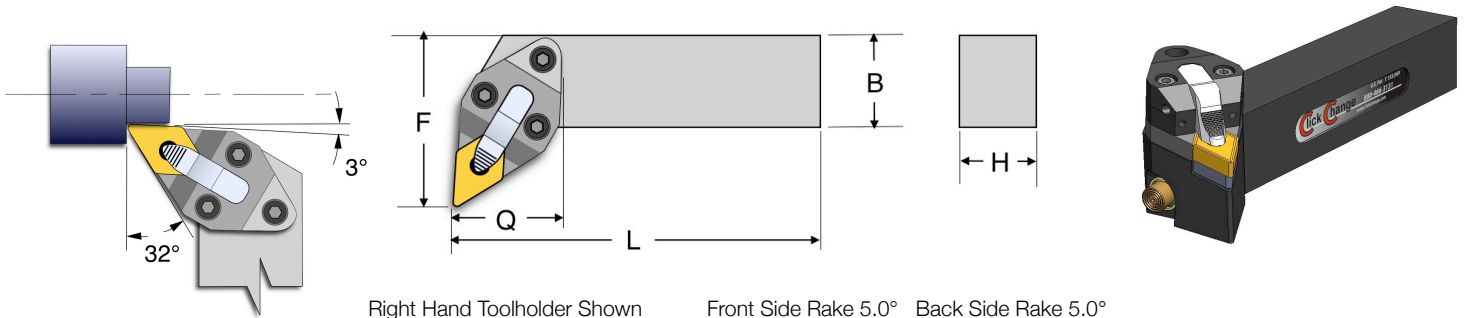

Right Hand Toolholder Shown
Gage insert is a DNMG-432
Insert height same as shank "H"

Front Side Rake 5.0° Back Side Rake 5.0°
Compound insert angle is 10.73°
measured along the insert centerline

Available Sizes

Catalog Number		Dimensions					Components		
Right Hand	Left Hand	H	L	B	F	Q	Piston	Shim	Seal
KDUNR-104A	KDUNL-104A	.625"	4.00"	1.00"	1.88"	1.21"	PS-6000-087	ICSN-432	VS-3125
KDUNR-104B	KDUNL-104B	.625"	4.50"	1.00"	1.88"	1.21"	PS-6000-087	ICSN-432	VS-3125
KDUNR-124A	KDUNL-124A	.750"	4.00"	1.00"	1.88"	1.21"	PS-6000-097	ICSN-432	VS-3125
KDUNR-124B	KDUNL-124B	.750"	4.50"	1.00"	1.88"	1.21"	PS-6000-097	ICSN-432	VS-3125
KDUNR-124C	KDUNL-124C	.750"	5.00"	1.00"	1.88"	1.21"	PS-6000-097	ICSN-432	VS-3125
KDUNR-164A	KDUNL-164A	1.00"	4.00"	1.00"	1.88"	1.21"	PS-6000-119	ICSN-432	VS-3125
KDUNR-164B	KDUNL-164B	1.00"	4.50"	1.00"	1.88"	1.21"	PS-6000-119	ICSN-432	VS-3125
KDUNR-164C	KDUNL-164C	1.00"	5.00"	1.00"	1.88"	1.21"	PS-6000-119	ICSN-432	VS-3125
KDUNR-164D	KDUNL-164D	1.00"	6.00"	1.00"	1.88"	1.21"	PS-6000-119	ICSN-432	VS-3125
KDUNR-204D	KDUNL-204D	1.25"	6.00"	1.25"	2.00"	1.21"	PS-6000-144	ICSN-432	VS-3125
KDUNR-244D	KDUNL-244D	1.50"	6.00"	1.50"	2.25"	1.21"	PS-6000-144	ICSN-432	VS-3125
KDUNR-1625H-15	KDUNL-1625H-15	16 mm	100 mm	25 mm	48 mm	31 mm	PS-6000-087	ICSN-432	VS-3125
KDUNR-1625K-15	KDUNL-1625K-15	16 mm	125 mm	25 mm	48 mm	31 mm	PS-6000-087	ICSN-432	VS-3125
KDUNR-2025K-15	KDUNL-2025K-15	20 mm	125 mm	25 mm	48 mm	31 mm	PS-6000-097	ICSN-432	VS-3125
KDUNR-2025M-15	KDUNL-2025M-15	20 mm	150 mm	25 mm	48 mm	31 mm	PS-6000-097	ICSN-432	VS-3125
KDUNR-2525K-15	KDUNL-2525K-15	25 mm	125 mm	25 mm	48 mm	31 mm	PS-6000-119	ICSN-432	VS-3125
KDUNR-2525M-15	KDUNL-2525M-15	25 mm	150 mm	25 mm	48 mm	31 mm	PS-6000-119	ICSN-432	VS-3125
KDUNR-3225P-15	KDUNL-3225P-15	32 mm	170 mm	25 mm	48 mm	31 mm	PS-6000-144	ICSN-432	VS-3125

Spare Parts

Shim Seat	Shim Screw	Insert Plate	Clamp Head	Piston	Cam Rod	Drive Spring	Front Seal
IDSN-432	SR-6000	IP-6041	HA-6040	see above	CR-6001	DS-1008	VS-3125

Clamp Head Spare Parts

Head Body	Clamp Lever	Axle Pin	Spring Pins	Cl. Springs	Set Screws	Cap Screws
CV-6040	CL-6041	HDPM-2.5x20	SP-6000	CS-6000	HSSM-3x3	HCSM-3x20

Click Change Lathe Turning Toolholders

U.S. Patent 7153069 other US & foreign patents pending

KVVNN

For use with: For: VNGA, VNGM, VNGP, VNMA, VNMG, VNMN, & VNMP inserts

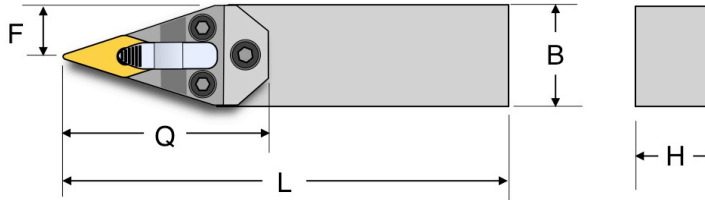
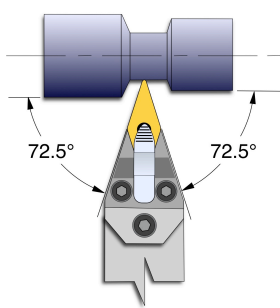

Gage insert is a VNMG-332
Insert height same as shank "H"

Front Side Rake 4.0° Back Side Rake 4.0°
Compound insert angle is 13.091°
measured along the insert centerline

Available Sizes

Catalog Number	Dimensions					Components		
	H	L	B	F	Q	Piston	Shim	Seal
KVVNN-104A	.625"	4.00"	1.00"	.500"	2.00"	PS-6000-073	none	none
KVVNN-104B	.625"	4.50"	1.00"	.500"	2.00"	PS-6000-073	none	none
KVVNN-124A	.750"	4.00"	1.00"	.500"	2.00"	PS-6000-110	none	none
KVVNN-124B	.750"	4.50"	1.00"	.500"	2.00"	PS-6000-110	none	none
KVVNN-124C	.750"	5.00"	1.00"	.500"	2.00"	PS-6000-110	none	none
KVVNN-164A	1.00"	4.00"	1.00"	.500"	2.00"	PS-6000-105	IVSN-322	VS-3125
KVVNN-164B	1.00"	4.50"	1.00"	.500"	2.00"	PS-6000-105	IVSN-322	VS-3125
KVVNN-164C	1.00"	5.00"	1.00"	.500"	2.00"	PS-6000-105	IVSN-322	VS-3125
KVVNN-164D	1.00"	6.00"	1.00"	.500"	2.00"	PS-6000-105	IVSN-322	VS-3125
KVVNN-204D	1.25"	6.00"	1.25"	.625"	2.00"	PS-6000-120	IVSN-322	VS-3125
KVVNN-244D	1.50"	6.00"	1.50"	.750"	2.00"	PS-6000-140	IVSN-322	VS-3125
KVVNN-1625H-16	16 mm	100 mm	25 mm	12.5 mm	51 mm	PS-6000-073	none	none
KVVNN-1625K-16	16 mm	125 mm	25 mm	12.5 mm	51 mm	PS-6000-073	none	none
KVVNN-2025K-16	20 mm	125 mm	25 mm	12.5 mm	51 mm	PS-6000-110	IVSN-322	VS-3125
KVVNN-2025M-16	20 mm	150 mm	25 mm	12.5 mm	51 mm	PS-6000-110	IVSN-322	VS-3125
KVVNN-2525K-16	25 mm	125 mm	25 mm	12.5 mm	51 mm	PS-6000-105	IVSN-322	VS-3125
KVVNN-2525M-16	25 mm	150 mm	25 mm	12.5 mm	51 mm	PS-6000-105	IVSN-322	VS-3125
KVVNN-3225P-16	32 mm	170 mm	25 mm	12.5 mm	51 mm	PS-6000-120	IVSN-322	VS-3125

Spare Parts

Shim Seat	Shim Screw	Insert Plate	Clamp Head	Piston	Cam Rod	Drive Spring	Front Seal
IVSN-322	SR-6050	IP-6051	HA-6050	see above	CR-6051	DS-1008	VS-3125

Clamp Head Spare Parts

Head Body	Clamp Lever	Axle Pin	Spring Pins	Cl. Springs	Set Screws	Cap Screws
CV-6050	CL-6050	HDPM-2.5x20	SP-6000	CS-6000	HSSM-3x3	HCSM-3x20

Click Change Lathe Turning Toolholders

U.S. Patent 7153069 other US & foreign patents pending

KVJNR/L For use with: For: VNGA, VNGM, VNGP, VNMA, VNMG, VNMN, & VNMP inserts

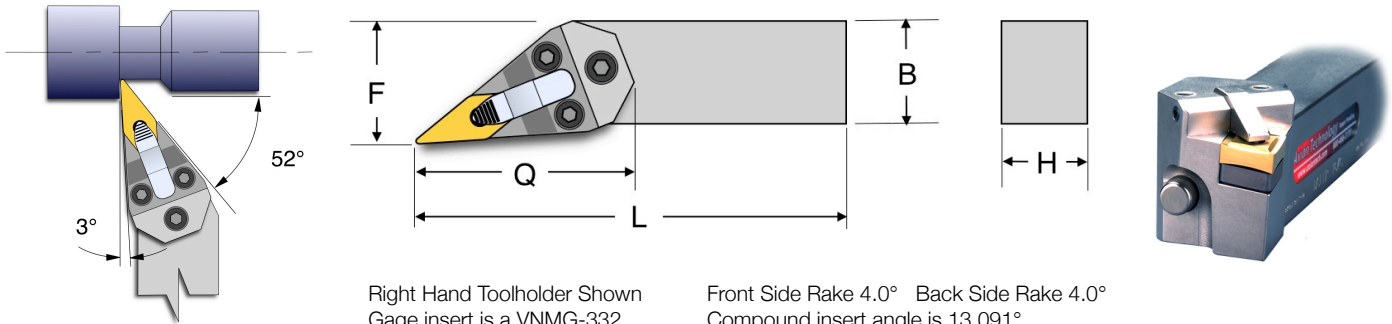

Right Hand Toolholder Shown
Gage insert is a VNMG-332
Insert height same as shank "H"

Front Side Rake 4.0° Back Side Rake 4.0°
Compound insert angle is 13.091°
measured along the insert centerline

Available Sizes

Catalog Number		Dimensions					Components		
Right Hand	Left Hand	H	L	B	F	Q	Piston	Shim	Seal
KVJNR-104A	KVJNL-104A	.625"	4.00"	1.00"	1.25"	1.95"	PS-6000-073	IVSN-322	none
KVJNR-104B	KVJNL-104B	.625"	4.50"	1.00"	1.25"	1.95"	PS-6000-073	IVSN-322	none
KVJNR-124A	KVJNL-124A	.750"	4.00"	1.00"	1.25"	1.95"	PS-6000-110	IVSN-322	none
KVJNR-124B	KVJNL-124B	.750"	4.50"	1.00"	1.25"	1.95"	PS-6000-110	IVSN-322	none
KVJNR-124C	KVJNL-124C	.750"	5.00"	1.00"	1.25"	1.95"	PS-6000-110	IVSN-322	none
KVJNR-164A	KVJNL-164A	1.00"	4.00"	1.00"	1.25"	1.95"	PS-6000-105	IVSN-322	VS-3125
KVJNR-164B	KVJNL-164B	1.00"	4.50"	1.00"	1.25"	1.95"	PS-6000-105	IVSN-322	VS-3125
KVJNR-164C	KVJNL-164C	1.00"	5.00"	1.00"	1.25"	1.95"	PS-6000-105	IVSN-322	VS-3125
KVJNR-164D	KVJNL-164D	1.00"	6.00"	1.00"	1.25"	1.95"	PS-6000-105	IVSN-322	VS-3125
KVJNR-204D	KVJNL-204D	1.25"	6.00"	1.25"	1.50"	1.95"	PS-6000-120	IVSN-322	VS-3125
KVJNR-244D	KVJNL-244D	1.50"	6.00"	1.50"	1.75"	1.95"	PS-6000-140	IVSN-322	VS-3125
KVJNR-1625H-16	KVJNL-1625H-16	16 mm	100 mm	25 mm	32 mm	49.5 mm	PS-6000-073	IVSN-322	none
KVJNR-1625K-16	KVJNL-1625K-16	16 mm	125 mm	25 mm	32 mm	49.5 mm	PS-6000-073	IVSN-322	none
KVJNR-2025K-16	KVJNL-2025K-16	20 mm	125 mm	25 mm	32 mm	49.5 mm	PS-6000-110	IVSN-322	VS-3125
KVJNR-2025M-16	KVJNL-2025M-16	20 mm	150 mm	25 mm	32 mm	49.5 mm	PS-6000-110	IVSN-322	VS-3125
KVJNR-2525K-16	KVJNL-2525K-16	25 mm	125 mm	25 mm	32 mm	49.5 mm	PS-6000-105	IVSN-322	VS-3125
KVJNR-2525M-16	KVJNL-2525M-16	25 mm	150 mm	25 mm	32 mm	49.5 mm	PS-6000-105	IVSN-322	VS-3125
KVJNR-3225P-16	KVJNL-3225P-16	32 mm	170 mm	25 mm	32 mm	49.5 mm	PS-6000-120	IVSN-322	VS-3125

Spare Parts

Shim Seat	Shim Screw	Insert Plate	Clamp Head	Piston	Cam Rod	Drive Spring	Front Seal
IVSN-322	SR-6050	IP-6051	HA-6050	see above	CR-6051	DS-1008	VS-3125

Clamp Head Spare Parts

Head Body	Clamp Lever	Axle Pin	Spring Pins	Cl Springs	Set Screws	Cap Screws
CV-6050	CL-6050	HDPM-2.5x20	SP-6000	CS-6000	HSSM-3x3	HCSM-3x20

Click Change Lathe Turning Toolholders

U.S. Patent 7153069 other US & foreign patents pending

KVQNR/L For use with: For: VNGA, VNGM, VNGP, VNMA, VNMG, VNMN, & VNMP inserts

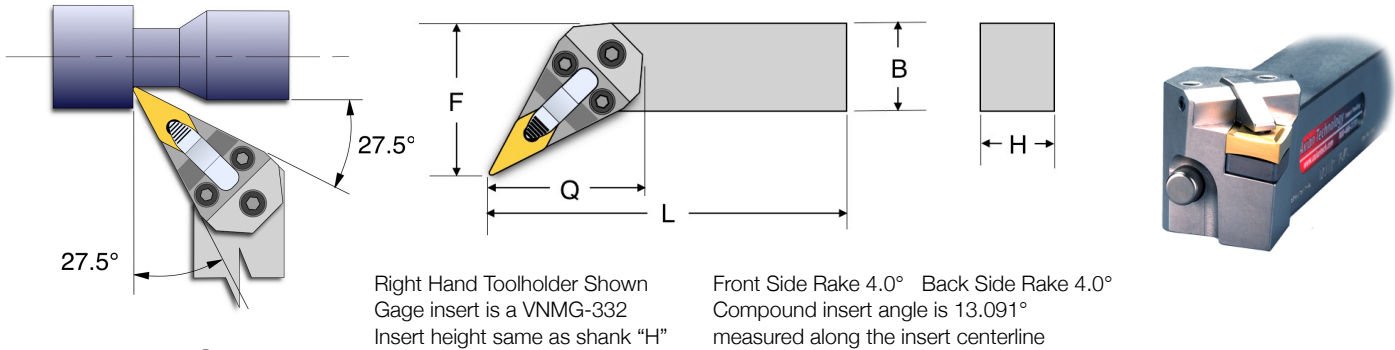

Available Sizes

Catalog Number		Dimensions					Components		
Right Hand	Left Hand	H	L	B	F	Q	Piston	Shim	Seal
KVQNR-104A	KVQNL-104A	.625"	4.00"	1.00"	1.63"	1.60"	PS-6000-073	IVSN-322	none
KVQNR-104B	KVQNL-104B	.625"	4.50"	1.00"	1.63"	1.60"	PS-6000-073	IVSN-322	none
KVQNR-124A	KVQNL-124A	.750"	4.00"	1.00"	1.63"	1.60"	PS-6000-110	IVSN-322	VS-3125
KVQNR-124B	KVQNL-124B	.750"	4.50"	1.00"	1.63"	1.60"	PS-6000-110	IVSN-322	VS-3125
KVQNR-124C	KVQNL-124C	.750"	5.00"	1.00"	1.63"	1.60"	PS-6000-110	IVSN-322	VS-3125
KVQNR-164A	KVQNL-164A	1.00"	4.00"	1.00"	1.63"	1.60"	PS-6000-105	IVSN-322	VS-3125
KVQNR-164B	KVQNL-164B	1.00"	4.50"	1.00"	1.63"	1.60"	PS-6000-105	IVSN-322	VS-3125
KVQNR-164C	KVQNL-164C	1.00"	5.00"	1.00"	1.63"	1.60"	PS-6000-105	IVSN-322	VS-3125
KVQNR-164D	KVQNL-164D	1.00"	6.00"	1.00"	1.63"	1.60"	PS-6000-105	IVSN-322	VS-3125
KVQNR-204D	KVQNL-204D	1.25"	6.00"	1.25"	1.50"	1.60"	PS-6000-120	IVSN-322	VS-3125
KVQNR-244D	KVQNL-244D	1.50"	6.00"	1.50"	1.75"	1.60"	PS-6000-140	IVSN-322	VS-3125
KVQNR-1625H-16	KVQNL-1625H-16	16 mm	100 mm	25 mm	41.5 mm	41 mm	PS-6000-073	IVSN-322	none
KVQNR-1625K-16	KVQNL-1625K-16	16 mm	125 mm	25 mm	41.5 mm	41 mm	PS-6000-073	IVSN-322	none
KVQNR-2025K-16	KVQNL-2025K-16	20 mm	125 mm	25 mm	41.5 mm	41 mm	PS-6000-110	IVSN-322	VS-3125
KVQNR-2025M-16	KVQNL-2025M-16	20 mm	150 mm	25 mm	41.5 mm	41 mm	PS-6000-110	IVSN-322	VS-3125
KVQNR-2525K-16	KVQNL-2525K-16	25 mm	125 mm	25 mm	41.5 mm	41 mm	PS-6000-105	IVSN-322	VS-3125
KVQNR-2525M-16	KVQNL-2525M-16	25 mm	150 mm	25 mm	41.5 mm	41 mm	PS-6000-105	IVSN-322	VS-3125
KVQNR-3225P-16	KVQNL-3225P-16	32 mm	170 mm	25 mm	41.5 mm	41 mm	PS-6000-120	IVSN-322	VS-3125

Spare Parts

Shim Seat	Shim Screw	Insert Plate	Clamp Head	Piston	Cam Rod	Drive Spring	Front Seal
IVSN-322	SR-6050	IP-6051	HA-6050	see above	CR-6051	DS-1008	VS-3125

Clamp Head Spare Parts

Head Body	Clamp Lever	Axle Pin	Spring Pins	Cl. Springs	Set Screws	Cap Screws
CV-6050	CL-6050	HDPM-2.5x20	SP-6000	CS-6000	HSSM-3x3	HCSM-3x20

Click Change Lathe Turning Toolholders

U.S. Patent 7153069 other US & foreign patents pending

KSDNN

For use with: SNG, SNGA, SNGN, SNMA, SNMG, SNMM, SNMN, SNMP, & SNU Inserts

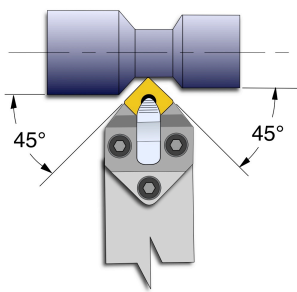

Gage insert is an SNMG-432
Insert height same as shank "H"

Front Side Rake 5.0° Back Side Rake 5.0°
Compound insert angle is 7.053°
measured along the insert centerline

Available Sizes

Catalog Number	Dimensions					Components		
	H	L	B	F	Q	Piston	Shim	Seal
KSDNN-104A	.625"	4.00"	1.13"	.565"	1.69"	PS-6000-079	none	none
KSDNN-104B	.625"	4.50"	1.13"	.565"	1.69"	PS-6000-079	none	none
KSDNN-124A	.750"	4.00"	1.13"	.565"	1.69"	PS-6000-090	none	none
KSDNN-124B	.750"	4.50"	1.13"	.565"	1.69"	PS-6000-090	none	none
KSDNN-124C	.750"	5.00"	1.13"	.565"	1.69"	PS-6000-090	none	none
KSDNN-164A	1.00"	4.00"	1.13"	.565"	1.69"	PS-6000-110	ISSN-433	VS-3125
KSDNN-164B	1.00"	4.50"	1.13"	.565"	1.69"	PS-6000-110	ISSN-433	VS-3125
KSDNN-164C	1.00"	5.00"	1.13"	.565"	1.69"	PS-6000-110	ISSN-433	VS-3125
KSDNN-164D	1.00"	6.00"	1.13"	.565"	1.69"	PS-6000-110	ISSN-433	VS-3125
KSDNN-204D	1.25"	6.00"	1.25"	.625"	1.69"	PS-6000-136	ISSN-433	VS-3125
KSDNN-244D	1.50"	6.00"	1.50"	.750"	1.69"	PS-6000-136	ISSN-433	VS-3125
KSDNN-1625H-12	16 mm	100 mm	29 mm	14.5 mm	43 mm	PS-6000-079	none	none
KSDNN-1625K-12	16 mm	125 mm	29 mm	14.5 mm	43 mm	PS-6000-079	none	none
KSDNN-2025K-12	20 mm	125 mm	29 mm	14.5 mm	43 mm	PS-6000-090	none	VS-3125
KSDNN-2025M-12	20 mm	150 mm	29 mm	14.5 mm	43 mm	PS-6000-090	none	VS-3125
KSDNN-2525K-12	25 mm	125 mm	29 mm	14.5 mm	43 mm	PS-6000-110	ISSN-433	VS-3125
KSDNN-2525M-12	25 mm	150 mm	29 mm	14.5 mm	43 mm	PS-6000-110	ISSN-433	VS-3125
KSDNN-3225P-12	32 mm	170 mm	29 mm	14.5 mm	43 mm	PS-6000-136	ISSN-433	VS-3125

Spare Parts

Shim Seat	Shim Screw	Insert Plate	Clamp Head	Piston	Cam Rod	Drive Spring	Front Seal
ISSN-433	SR-6000	IP-6011	HA-6001	see above	CR-6001	DS-1008	VS-3125

Clamp Head Spare Parts

Head Body	Clamp Lever	Axle Pin	Spring Pins	Cl Springs	Set Screws	Cap Screws
CV-6001	CL-6001	HDPM-2.5x20	SP-6000	CS-6000	HSSM-3x3	HCSM-3x20

Click Change Lathe Turning Toolholders

U.S. Patent 7153069 other US & foreign patents pending

KSRNR/L For use with: SNG, SNGA, SNGN, SNMA, SNMG, SNMM, SNMN, SNMP, & SNU Inserts

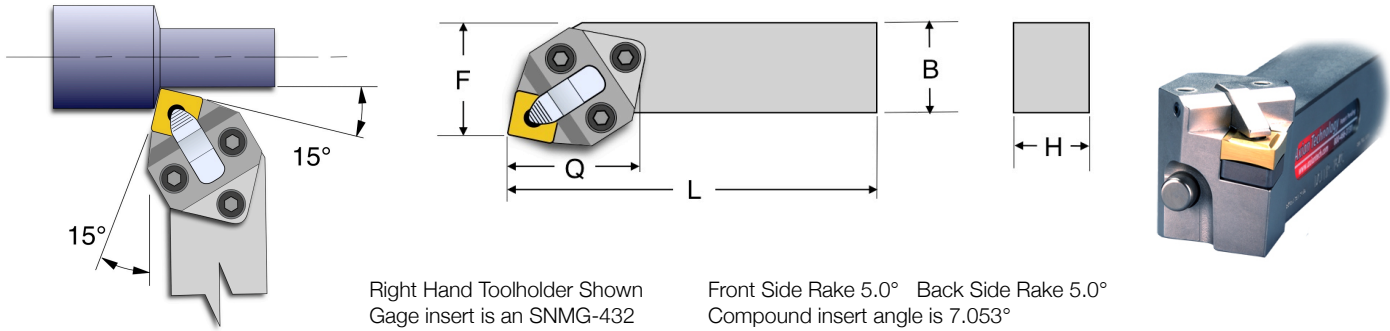

Right Hand Toolholder Shown
Gage insert is an SNMG-432
Insert height same as shank "H"

Front Side Rake 5.0° Back Side Rake 5.0°
Compound insert angle is 7.053°
measured along the insert centerline

Available Sizes

Catalog Number		Dimensions					Components		
Right Hand	Left Hand	H	L	B	F	Q	Piston	Shim	Seal
KSRNR-104A	KSRNL-104A	.625"	4.00"	1.00"	1.13"	1.49"	PS-6000-079	ISSN-433	none
KSRNR-104B	KSRNL-104B	.625"	4.50"	1.00"	1.13"	1.49"	PS-6000-079	ISSN-433	none
KSRNR-124A	KSRNL-124A	.750"	4.00"	1.00"	1.13"	1.49"	PS-6000-090	ISSN-433	none
KSRNR-124B	KSRNL-124B	.750"	4.50"	1.00"	1.13"	1.49"	PS-6000-090	ISSN-433	none
KSRNR-124C	KSRNL-124C	.750"	5.00"	1.00"	1.13"	1.49"	PS-6000-090	ISSN-433	none
KSRNR-164A	KSRNL-164A	1.00"	4.00"	1.00"	1.13"	1.49"	PS-6000-110	ISSN-433	VS-3125
KSRNR-164B	KSRNL-164B	1.00"	4.50"	1.00"	1.13"	1.49"	PS-6000-110	ISSN-433	VS-3125
KSRNR-164C	KSRNL-164C	1.00"	5.00"	1.00"	1.13"	1.49"	PS-6000-110	ISSN-433	VS-3125
KSRNR-164D	KSRNL-164D	1.00"	6.00"	1.00"	1.13"	1.49"	PS-6000-110	ISSN-433	VS-3125
KSRNR-204D	KSRNL-204D	1.25"	6.00"	1.25"	1.38"	1.49"	PS-6000-136	ISSN-433	VS-3125
KSRNR-244D	KSRNL-244D	1.50"	6.00"	1.50"	1.63"	1.49"	PS-6000-136	ISSN-433	VS-3125
KSRNR-1625H-12	KSRNL-1625H-12	16 mm	100 mm	25 mm	29 mm	38 mm	PS-6000-079	ISSN-433	none
KSRNR-1625K-12	KSRNL-1625K-12	16 mm	125 mm	25 mm	29 mm	38 mm	PS-6000-079	ISSN-433	none
KSRNR-2025K-12	KSRNL-2025K-12	20 mm	125 mm	25 mm	29 mm	38 mm	PS-6000-090	ISSN-433	VS-3125
KSRNR-2025M-12	KSRNL-2025M-12	20 mm	150 mm	25 mm	29 mm	38 mm	PS-6000-090	ISSN-433	VS-3125
KSRNR-2525K-12	KSRNL-2525K-12	25 mm	125 mm	25 mm	29 mm	38 mm	PS-6000-110	ISSN-433	VS-3125
KSRNR-2525M-12	KSRNL-2525M-12	25 mm	150 mm	25 mm	29 mm	38 mm	PS-6000-110	ISSN-433	VS-3125
KSRNR-3225P-12	KSRNL-3225P-12	32 mm	170 mm	25 mm	29 mm	38 mm	PS-6000-136	ISSN-433	VS-3125

Spare Parts

Shim Seat	Shim Screw	Insert Plate	Clamp Head	Piston	Cam Rod	Drive Spring	Front Seal
ISSN-433	SR-6000	IP-6011	HA-6001	see above	CR-6001	DS-1008	VS-3125

Clamp Head Spare Parts

Head Body	Clamp Lever	Axle Pin	Spring Pins	Cl Springs	Set Screws	Cap Screws
CV-6001	CL-6001	HDPM-2.5x20	SP-6000	CS-6000	HSSM-3x3	HCSM-3x20

Click Change Lathe Turning Toolholders

U.S. Patent 7153069 other US & foreign patents pending

KSKNR/L For use with: SNG, SNGA, SNGN, SNMA, SNMG, SNMM, SNMN, SNMP, & SNU Inserts

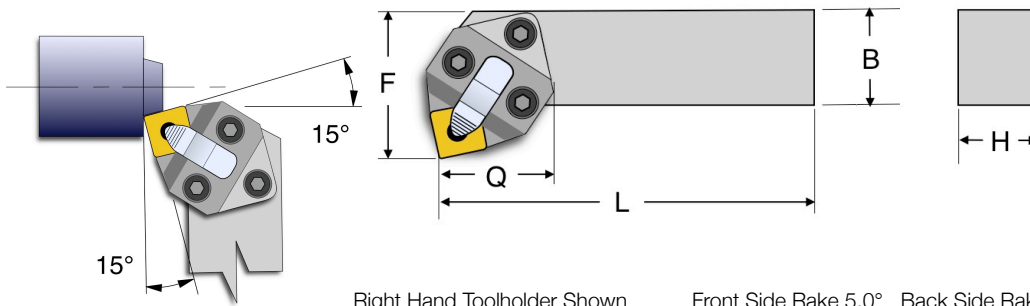

Right Hand Toolholder Shown
Gage insert is an SNMG-432
Insert height same as shank "H"

Front Side Rake 5.0° Back Side Rake 5.0°
Compound insert angle is 7.053°
measured along the insert centerline







Available Sizes

Catalog Number		Dimensions					Components		
Right Hand	Left Hand	H	L	B	F	Q	Piston	Shim	Seal
KSKNR-104A	KSKNL-104A	.625"	4.00"	1.00"	1.53"	1.10"	PS-6000-079	ISSN-433	none
KSKNR-104B	KSKNL-104B	.625"	4.50"	1.00"	1.53"	1.10"	PS-6000-079	ISSN-433	none
KSKNR-124A	KSKNL-124A	.750"	4.00"	1.00"	1.53"	1.10"	PS-6000-090	ISSN-433	none
KSKNR-124B	KSKNL-124B	.750"	4.50"	1.00"	1.53"	1.10"	PS-6000-090	ISSN-433	none
KSKNR-124C	KSKNL-124C	.750"	5.00"	1.00"	1.53"	1.10"	PS-6000-090	ISSN-433	none
KSKNR-164A	KSKNL-164A	1.00"	4.00"	1.00"	1.53"	1.10"	PS-6000-110	ISSN-433	VS-3125
KSKNR-164B	KSKNL-164B	1.00"	4.50"	1.00"	1.53"	1.10"	PS-6000-110	ISSN-433	VS-3125
KSKNR-164C	KSKNL-164C	1.00"	5.00"	1.00"	1.53"	1.10"	PS-6000-110	ISSN-433	VS-3125
KSKNR-164D	KSKNL-164D	1.00"	6.00"	1.00"	1.53"	1.10"	PS-6000-110	ISSN-433	VS-3125
KSKNR-204D	KSKNL-204D	1.25"	6.00"	1.25"	1.75"	1.10"	PS-6000-136	ISSN-433	VS-3125
KSKNR-244D	KSKNL-244D	1.50"	6.00"	1.50"	2.00"	1.10"	PS-6000-136	ISSN-433	VS-3125
KSKNR-1625H-12	KSKNL-1625H-12	16 mm	100 mm	25 mm	39 mm	28 mm	PS-6000-079	ISSN-433	none
KSKNR-1625K-12	KSKNL-1625K-12	16 mm	125 mm	25 mm	39 mm	28 mm	PS-6000-079	ISSN-433	none
KSKNR-2025K-12	KSKNL-2025K-12	20 mm	125 mm	25 mm	39 mm	28 mm	PS-6000-090	ISSN-433	VS-3125
KSKNR-2025M-12	KSKNL-2025M-12	20 mm	150 mm	25 mm	39 mm	28 mm	PS-6000-090	ISSN-433	VS-3125
KSKNR-2525K-12	KSKNL-2525K-12	25 mm	125 mm	25 mm	39 mm	28 mm	PS-6000-110	ISSN-433	VS-3125
KSKNR-2525M-12	KSKNL-2525M-12	25 mm	150 mm	25 mm	39 mm	28 mm	PS-6000-110	ISSN-433	VS-3125
KSKNR-3225P-12	KSKNL-3225P-12	32 mm	170 mm	25 mm	39 mm	28 mm	PS-6000-136	ISSN-433	VS-3125

Spare Parts

Shim Seat	Shim Screw	Insert Plate	Clamp Head	Piston	Cam Rod	Drive Spring	Front Seal
							
ISSN-433	SR-6000	IP-6011	HA-6001	see above	CR-6001	DS-1008	VS-3125

Clamp Head Spare Parts

Head Body	Clamp Lever	Axle Pin	Spring Pins	Cl Springs	Set Screws	Cap Screws
						
CV-6001	CL-6001	HDPM-2.5x20	SP-6000	CS-6000	HSSM-3x3	HCSM-3x20

Click Change Lathe Turning Toolholders

U.S. Patent 7153069 other US & foreign patents pending

KRGNR/L For use with: RNGN, RNMA, RNMG, & RNMN Inserts

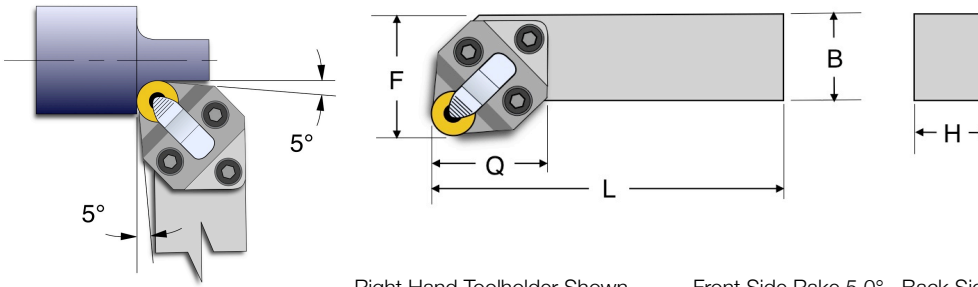

Right Hand Toolholder Shown
Gage insert is an RNMG-43
Insert height same as shank "H"

Front Side Rake 5.0° Back Side Rake 5.0°
Compound insert angle is 7.053°
measured along the insert centerline

Available Sizes

Catalog Number		Dimensions					Components		
Right Hand	Left Hand	H	L	B	F	Q	Piston	Shim	Seal
KRGNR-104A	KRGNL-104A	.625"	4.00"	1.00"	1.23"	1.23"	PS-6000-079	IRSN-43	none
KRGNR-104B	KRGNL-104B	.625"	4.50"	1.00"	1.23"	1.23"	PS-6000-079	IRSN-43	none
KRGNR-124A	KRGNL-124A	.750"	4.00"	1.00"	1.23"	1.23"	PS-6000-090	IRSN-43	none
KRGNR-124B	KRGNL-124B	.750"	4.50"	1.00"	1.23"	1.23"	PS-6000-090	IRSN-43	none
KRGNR-124C	KRGNL-124C	.750"	5.00"	1.00"	1.23"	1.23"	PS-6000-090	IRSN-43	none
KRGNR-164A	KRGNL-164A	1.00"	4.00"	1.00"	1.23"	1.23"	PS-6000-110	IRSN-43	VS-3125
KRGNR-164B	KRGNL-164B	1.00"	4.50"	1.00"	1.23"	1.23"	PS-6000-110	IRSN-43	VS-3125
KRGNR-164C	KRGNL-164C	1.00"	5.00"	1.00"	1.23"	1.23"	PS-6000-110	IRSN-43	VS-3125
KRGNR-164D	KRGNL-164D	1.00"	6.00"	1.00"	1.23"	1.23"	PS-6000-110	IRSN-43	VS-3125
KRGNR-204D	KRGNL-204D	1.25"	6.00"	1.25"	1.50"	1.23"	PS-6000-136	IRSN-43	VS-3125
KRGNR-244D	KRGNL-244D	1.50"	6.00"	1.50"	1.75"	1.23"	PS-6000-136	IRSN-43	VS-3125
KRGNR-1625H-12	KRGNL-1625H-12	16 mm	100 mm	25 mm	32 mm	32 mm	PS-6000-079	IRSN-43	none
KRGNR-1625K-12	KRGNL-1625K-12	16 mm	125 mm	25 mm	32 mm	32 mm	PS-6000-079	IRSN-43	none
KRGNR-2025K-12	KRGNL-2025K-12	20 mm	125 mm	25 mm	32 mm	32 mm	PS-6000-090	IRSN-43	VS-3125
KRGNR-2025M-12	KRGNL-2025M-12	20 mm	150 mm	25 mm	32 mm	32 mm	PS-6000-090	IRSN-43	VS-3125
KRGNR-2525K-12	KRGNL-2525K-12	25 mm	125 mm	25 mm	32 mm	32 mm	PS-6000-110	IRSN-43	VS-3125
KRGNR-2525M-12	KRGNL-2525M-12	25 mm	150 mm	25 mm	32 mm	32 mm	PS-6000-110	IRSN-43	VS-3125
KRGNR-3225P-12	KRGNL-3225P-12	32 mm	170 mm	25 mm	32 mm	32 mm	PS-6000-136	IRSN-43	VS-3125

Spare Parts

Shim Seat	Shim Screw	Insert Plate	Clamp Head	Piston	Cam Rod	Drive Spring	Front Seal
IRSN-43	SR-6000	IP-6021	HA-6001	see above	CR-6001	DS-1008	VS-3125

Clamp Head Spare Parts

Head Body	Clamp Lever	Axle Pin	Spring Pins	Cl Springs	Set Screws	Cap Screws
CV-6001	CL-6001	HDPM-2.5x20	SP-6000	CS-6000	HSSM-3x3	HCSM-3x20