



SHORT
CAPTO



E | CLASS

SHORT
CAPTO



Short Capto

- ▶ More than 20,000 different tool holders are available for machine operators, including VDI tool holders with shaft diameters of 16-80 mm, machine-specific holders for Mazak, Okuma or Mori Seiki. In addition to standard holders, you will also find Capto, HSK, KM and ABS.

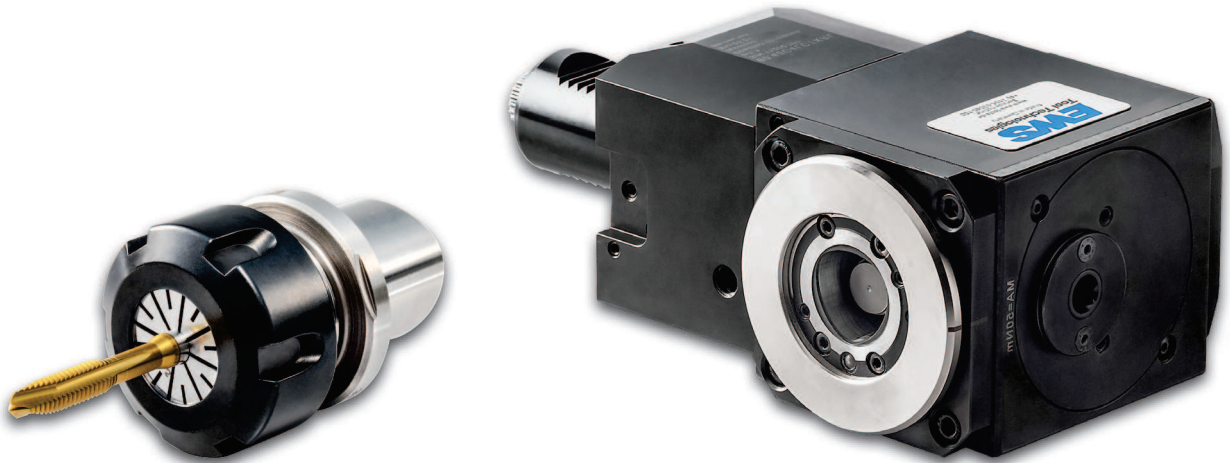

MORE AVAILABLE CUTTING TOOL LENGTH

- + Short toolholder projection with no gripper groove

HIGHER ACCURACY

- + Smaller run-out error through reduced projection length

HIGHER STABILITY

- + Lower vibrations through reduced tool projection length

LONGER LIFETIME

- + Lower load on the bearings through shorter torsion

AVAILABLE INSERTS

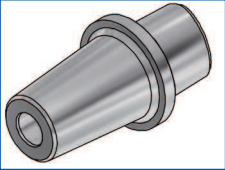
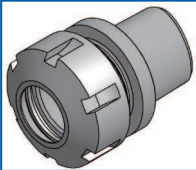
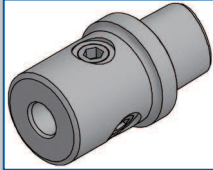
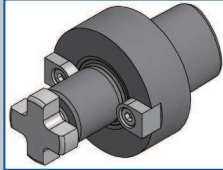
			
SHRINK CHUCK	COLLET CHUCK	U-DRILL HOLDER	MILLING ARBOR