



ETP HYDRO-FIX®

Hydraulic high precision clamping unit



TOOLING & MACHINERY

COMPLETE METALWORKING SOLUTIONS

(800) 991-4225
ISO Certified

www.ahbinc.com
customerservice@ahbinc.com

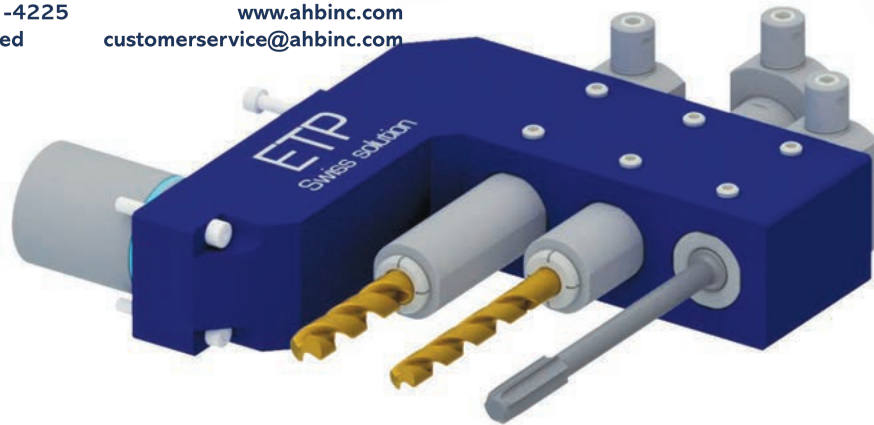

Swiss type
Lathes

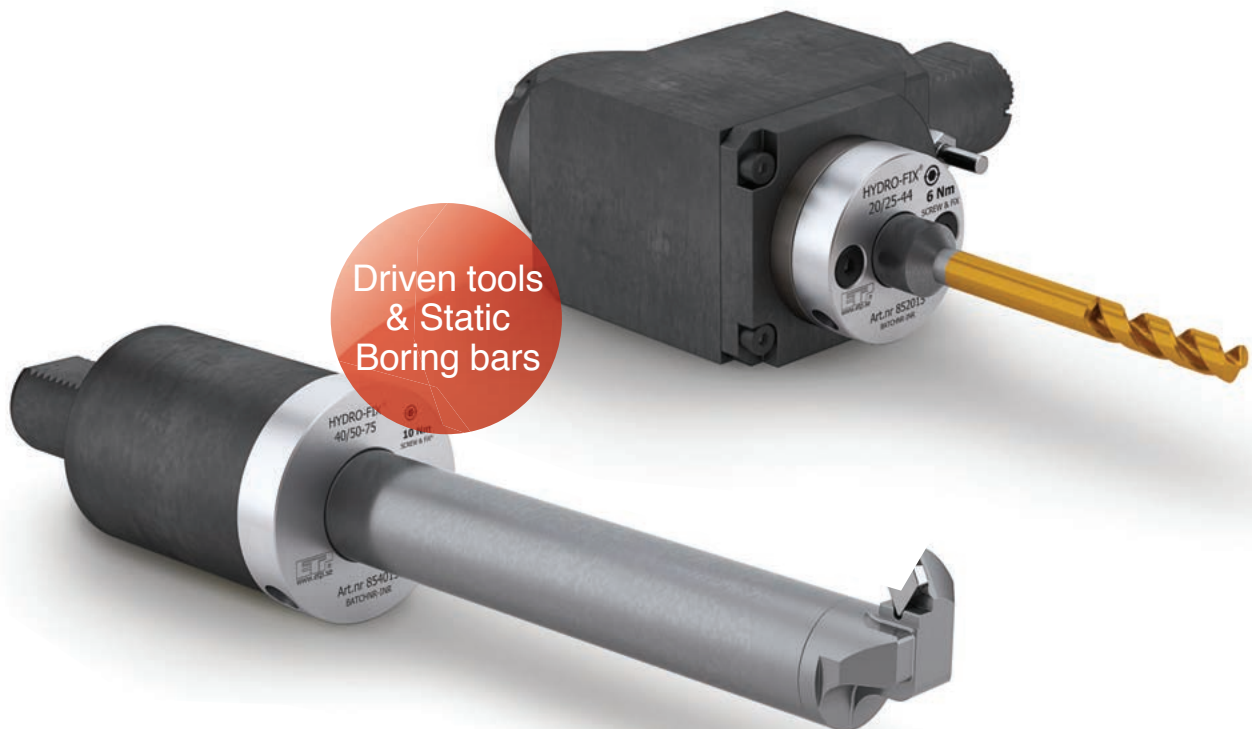

Driven tools
& Static
Boring bars



ETP HYDRO-FIX S[®]

Hydraulic high precision clamping unit

Increases your productivity!



ETP HYDRO-FIX S clamping units are excellent for static front and back drilling operations. With the one screw fix system it is quick and easy to handle. Precision hydraulic tool centering is achieved and therefore the tool life and setup time is improved. The clamping unit allows for larger/deeper drilling, quick tool changes, absorbs/reduces vibration, improves surface quality and best of all: increases your productivity!

BENEFITS & FEATURES

- Reduced vibrations
- Improved surface quality
- Increased tool life
- Quick and easy handling

Versions

Front activation

HYDRO-FIX S clamps around the tool and simultaneously inside the static block/holder for a perfect centering. Block/holder set screws are **NOT** used!



Back activation

HYDRO-FIX S clamps around the tool. The static block's set screws are used to clamp on the milled flat of HYDRO-FIX S, after adjusting the length of the assembly.



Swiss machine turning – with ETP HYDRO-FIX S hydraulic high precision clamping unit



Front activation version in Drill arm application. Tool change in 30 seconds!



Back activation version in Drill arm application. Tool change in 30 seconds!

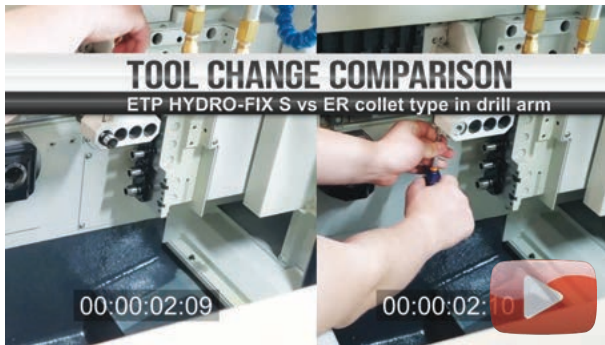

HYDRO-FIX S vs ER collet type tool holder in Drill arm application. Save valuable time in set-up and tool changes!

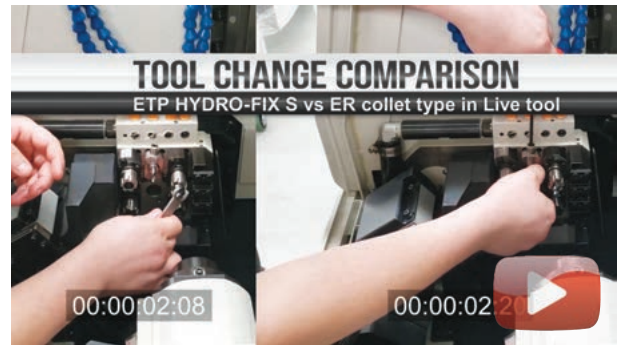

HYDRO-FIX S vs ER collet type tool holder in Live tool station for static drilling. Save valuable time in set-up and tool changes!

youtube.com/etptransmission

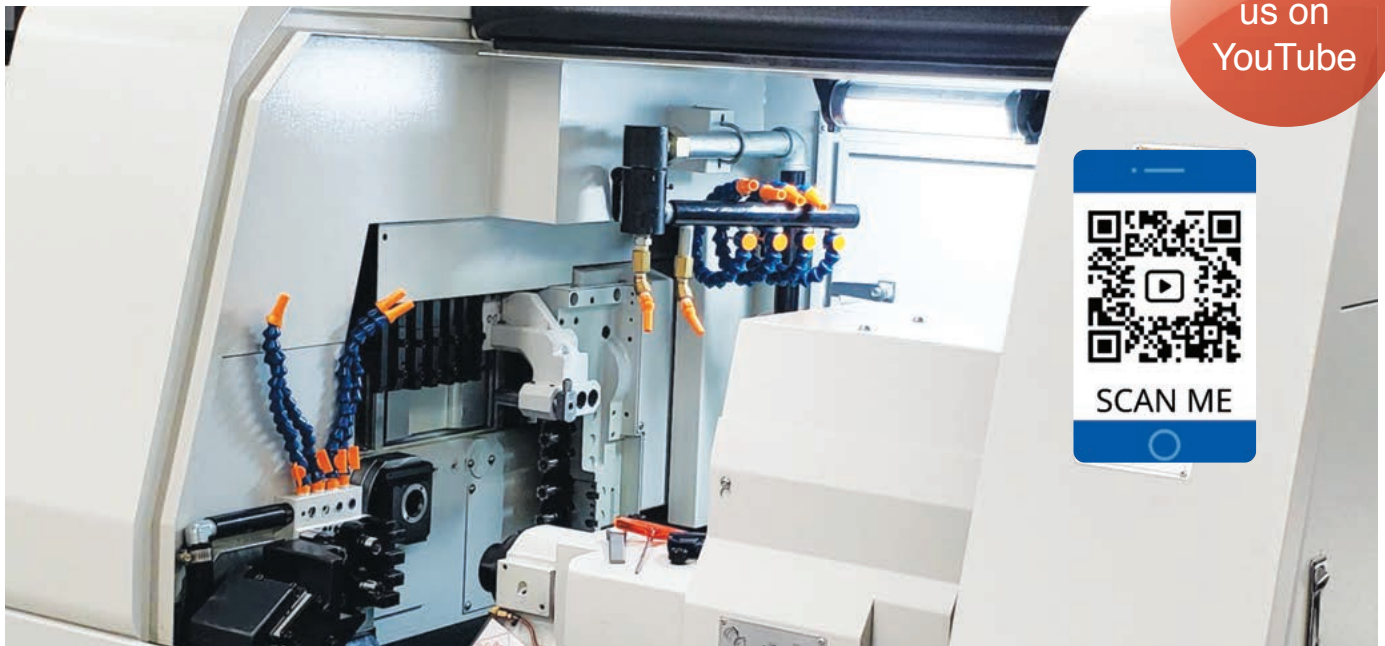

ETP HYDRO-FIX S®

Front activation version

For
Swiss type
Lathes

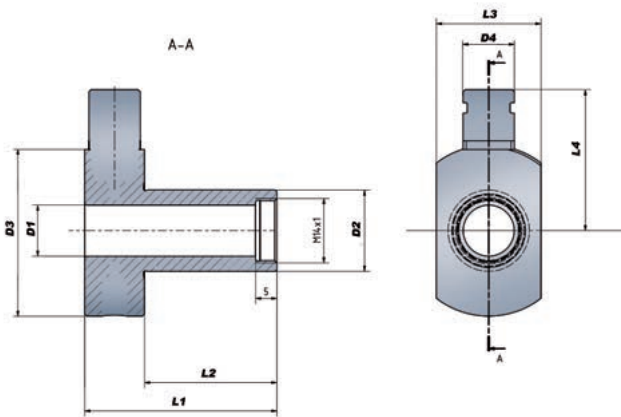

Static front & back working tools

BENEFITS & FEATURES

- Perfect centering in the block
- Replaces ER11 – ER32 collet holders
- Use larger and longer tools
- Shank clamping range: 25 to 1 mm and to 1/8" with reduction sleeves
- Quick and easy handling
- Reduced vibrations
- Improved surface quality
- Increased tool life

Back stop/Coolant port G 1/8" – to be ordered separately

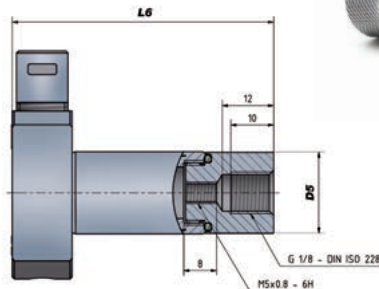

Block/holder set screws are **NOT** used!

Technical Specification

Part no.	Item description	Dimensions, mm								Dimensions with Back stop/Coolant port G 1/8"		
		D1*	D2**	D3	D4	L1	L2	L3	L4	L6	D5	Part no. - Back stop/Coolant port G 1/8" Includes adjustment screw M5x0.8-16***
○ 664090	HYDRO-FIX S-12/3/4"-31	12	19.05	40	12	45	31	24.5	33	61	18.85	664000-10
○ 664100	HYDRO-FIX S-12/20-31	12	20	40	12	45	31	24.5	33	61	18.85	664000-10
● 663740	HYDRO-FIX S-12/22-31	12	22	40	12	45	31	24.5	33	61	18.85	664000-10
○ 664110	HYDRO-FIX S-12/25-31	12	25	40	12	45	31	27.5	33	61	18.85	664000-10
○ 664120	HYDRO-FIX S-12/1"-31	12	25.4	40	12	45	31	27.5	33	61	18.85	664000-10
● 663750	HYDRO-FIX S-20/25-30*	20	25	44	12	44	30	27.5	35			
○ 664130	HYDRO-FIX S-20/1"-30*	20	25.4	44	12	44	30	27.5	35			
● 663760	HYDRO-FIX S-25/32-34*	25	32	44	12	48	34	34.5	38			

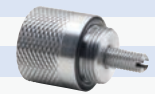

- From stock
- On request

*) These sizes are **NOT** threaded with an M14x1 for a Back stop/coolant port. Pressure screw angled 15".



Information:

- *) Tool/toolbar shank h6 or h7 can be used.
- **) Recommended tolerance of toolholder bore - H7.
- ***) Adjustment screw M5x0.8-16 can also be ordered separately as spare part. Part no. S041

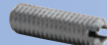

Accessories:

Use preset Torque Wrench to ensure correct mounting of tools. 6 Nm - Part no. 19055



ETP HYDRO-FIX can be used with reduction sleeves. For additional information see section Accessories.



Adaptors:

Male G 1/8" to Female 1/4" NPT Part no. 19151
Male G 1/8" to Male 1/4" JIC Part no. 19150

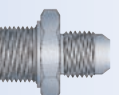
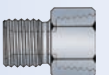

ETP HYDRO-FIX S[®]

Back activation version

For
Swiss type
Lathes



Static front & back
working tools

BENEFITS & FEATURES

- Length adjustability with 4 flats
- Replaces ER11 – ER32 collet holders
- Use larger and longer tools
- Shank clamping range: 25 to 1 mm and to 1/8" with reducing sleeves
- Quick and easy handling
- Reduced vibrations
- Improved surface quality
- Increased tool life

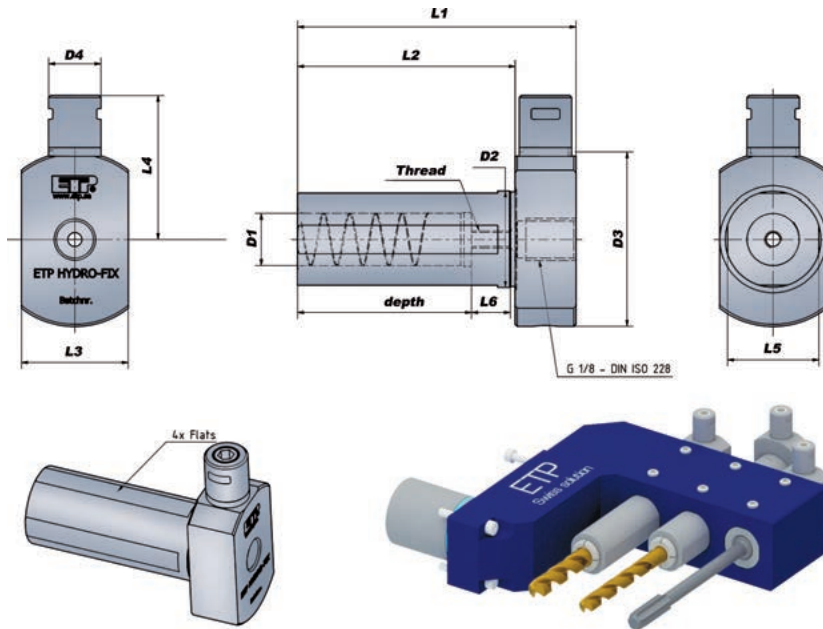

Set screws are used to clamp on the milled flat, after adjusting the length of the assembly.

Technical Specification

Part no.	Item description	Dimensions, mm												Thread	L6
		D1	D2	D3	D4	L1	L2	depth	L3	L4	L5				
● 664000	HYDRO-FIX S-12/3/4"-50	12	19.05	40	12	64	50	40	24.5	33	21	M5x0.8 - 6H	9		
● 664010	HYDRO-FIX S-12/3/4"-75	12	19.05	40	12	89	75	40	24.5	33	21	M5x0.8 - 6H	10		
○ 664020	HYDRO-FIX S-12/3/4"-100	12	19.05	40	12	114	100	40	24.5	33	21	M5x0.8 - 6H	10		
○ 664030	HYDRO-FIX S-12/20-75	12	20	40	12	89	75	40	24.5	33	21	M5x0.8 - 6H	10		
○ 664040	HYDRO-FIX S-12/20-100	12	20	40	12	114	100	40	24.5	33	21	M5x0.8 - 6H	10		
● 663700	HYDRO-FIX S-12/22-50	12	22	40	12	64	50	40	24.5	33	21	M5x0.8 - 6H	9		
● 663770	HYDRO-FIX S-12/22-75	12	22	40	12	89	75	40	24.5	33	21	M5x0.8 - 6H	10		
● 663720	HYDRO-FIX S-12/22-100	12	22	40	12	114	100	40	24.5	33	21	M5x0.8 - 6H	10		
● 663780	HYDRO-FIX S-12/22-115	12	22	40	12	129	115	40	24.5	33	21	M5x0.8 - 6H	10		
● 663710	HYDRO-FIX S-12/25-50	12	25	40	12	64	50	40	27.5	33	24	M5x0.8 - 6H	9		
○ 663790	HYDRO-FIX S-12/25-75	12	25	40	12	89	75	40	27.5	33	24	M5x0.8 - 6H	10		
● 663730	HYDRO-FIX S-12/25-100	12	25	40	12	114	100	40	27.5	33	24	M5x0.8 - 6H	10		
● 664050	HYDRO-FIX S-12/1"-50	12	25.4	40	12	64	50	40	27.5	33	24	M5x0.8 - 6H	9		
○ 664060	HYDRO-FIX S-12/1"-75	12	25.4	40	12	89	75	40	27.5	33	24	M5x0.8 - 6H	10		
● 664070	HYDRO-FIX S-12/1"-100	12	25.4	40	12	114	100	40	27.5	33	24	M5x0.8 - 6H	10		
○ 664080	HYDRO-FIX S-20/32-50	20	32	40	12	64	50	52	34.5	33	30.8	M5x0.8 - 6H	9		
○ 663810	HYDRO-FIX S-20/32-75	20	32	40	12	89	75	52	34.5	33	30.8	M5x0.8 - 6H	10		
○ 663820	HYDRO-FIX S-20/32-100	20	32	40	12	114	100	52	34.5	33	30.8	M5x0.8 - 6H	10		

- From stock
- On request

Information:

- *) Tool/toolbar shank h6 or h7 can be used.
- **) Recommended tolerance of toolholder bore - H7.

Adjustment screw M5x0.8-16 included in shipment. It can also be ordered separately as spare part. Part no. S041

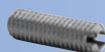

Accessories:

Use preset Torque Wrench to ensure correct mounting of tools. 6 Nm - Part no. 19055



ETP HYDRO-FIX can be used with reduction sleeves. For additional information see section Accessories.



Adaptors:

Male G 1/8" to Female 1/4" NPT Part no. 19151

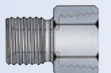

Male G 1/8" to Male 1/4" JIC Part no. 19150

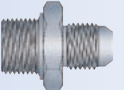

ETP HYDRO-FIX®

Hydraulic high precision clamping unit



New
Generation



ETP HYDRO-FIX clamping units are excellent for boring bars for internal and external turning as well as in driven toolholders. With the one screw fix system it is quick and easy to handle.

The clamping is uniform around the tool and therefore the tool life is improved. The clamping unit absorbs and reduces vibration, improves surface quality and best of all increases your productivity!

BENEFITS & FEATURES

- Reduced vibrations
- Increased speed and/or feed
- Improved surface quality
- Increased tool life
- Quick and easy handling
- Increased overhang possible
- Safe clamping of solid carbide tools. No risc of damages

ETP HYDRO-FIX®

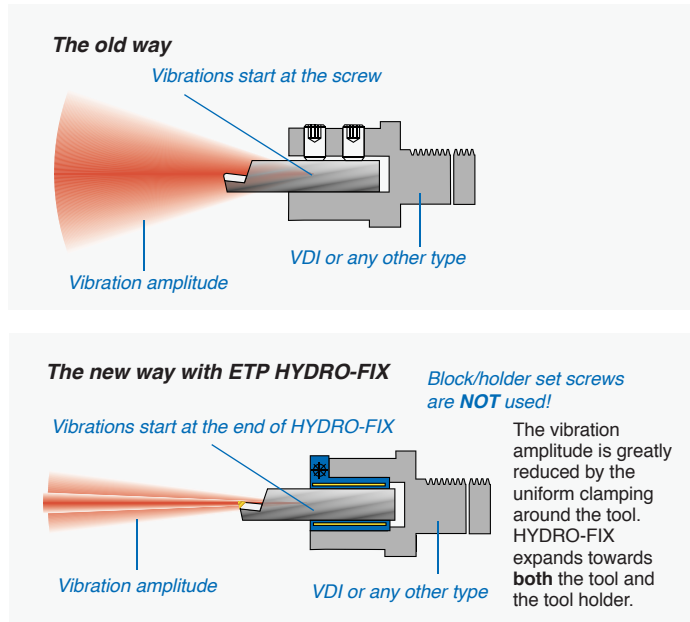
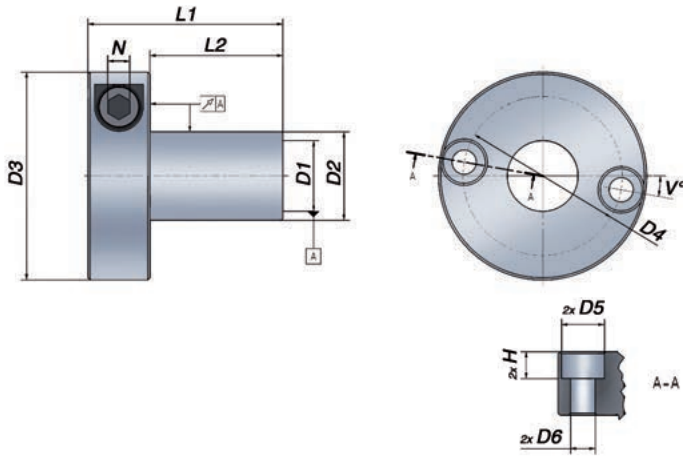

Metric range

Technical Specification

Part no.	Item description	Dimensions, mm					Recommended screws DIN 915, 12.9					Pressure screw		Runout mm	T* Nm	Weight kg
		D1*	D2**	D3	L1	L2	D4	D5	D6	H	V°	N	Tt*** Nm			
● 851215	HYDRO-FIX 12/16-38	12	16	43.5	38	24	28	9.5	5.5	6	5	5	6	0.006	60	0.15
● 851615	HYDRO-FIX 16/20-44	16	20	47	44	30	36	9.5	5.5	6	10	5	6	0.006	165	0.17
● 852015	HYDRO-FIX 20/25-44	20	25	52	44	30	36	11	6.5	7		5	6	0.006	260	0.21
● 852515	HYDRO-FIX 25/32-48	25	32	59	48	34	44	11	6.5	7		5	6	0.010	350	0.30
● 853215	HYDRO-FIX 32/40-53	32	40	69.5	53	39	52	11	6.5	7		5	6	0.010	630	0.43
○ 854015	HYDRO-FIX 40/50-69	40	50	79	69	55						5	6	0.015	320	0.96
○ 854215	HYDRO-FIX 42/50-76	42	50	89	76	56						8	10	0.015	800	0.94
○ 855015	HYDRO-FIX 50/60-80	50	60	98.5	80	60						8	10	0.015	800	1.23
○ 856015	HYDRO-FIX 60/80-90	60	80	115.5	90	70						8	10	0.015	800	2.34

Inch range

Technical Specification

Part no.	Item description	Dimensions, inch					Recommended screws DIN 915, 12.9					Pressure screw		Runout inch	T* ft·lb	Weight kg
		D1*	D2**	D3	L1	L2	D4	D5	D6	H	V°	N	Tt*** Nm			
● 851315	HYDRO-FIX 1/2"/5/8"-38	0.500	0.625	1.713	1.496	0.945	1.102	0.374	0.217	0.236	5	0.197	6	0.00024	44	0.15
● 851515	HYDRO-FIX 5/8"/3/4"-44	0.625	0.750	1.850	1.732	1.181	1.417	0.374	0.217	0.236	10	0.197	6	0.00024	121	0.17
● 851915	HYDRO-FIX 3/4"/1"-44	0.750	1.000	2.047	1.732	1.181	1.417	0.433	0.256	0.276		0.197	6	0.00039	191	0.21
● 852615	HYDRO-FIX 1"/1 1/4"-48	1.000	1.250	2.323	1.890	1.339	1.732	0.433	0.256	0.276		0.197	6	0.00039	258	0.30
● 853115	HYDRO-FIX 1 1/4"/1 1/2"-53	1.250	1.500	2.736	2.087	1.535	2.047	0.433	0.256	0.276		0.197	6	0.00039	465	0.43
● 853915	HYDRO-FIX 1 1/2"/2"-69	1.500	2.000	3.110	2.717	2.165						0.197	6	0.00059	118	1.06
○ 855115	HYDRO-FIX 2"/2 1/2"-80	2.000	2.500	3.996	3.150	2.362						0.315	10	0.00059	590	1.42
○ 856315	HYDRO-FIX 2 1/2"/3"-93	2.500	3.000	4.685	3.661	2.874						0.315	10	0.00059	885	1.98

***) T_t = Recommended tightening torque for the screw in Nm! Further tightening does not increase the pressure.

*) T = Transmittable torque using a h6 cylindrical tool, full depth (L1) insert.

For dimensions 12 mm (1/2") – 20 mm (3/4"):

When using a non-cylindrical tool/toolbar – we recommend the use of a reduction sleeve to avoid plastic deformation of ETP HYDRO-FIX.

- From stock
- On request

Information:

- *) Tool/toolbar shank h6 or h7 can be used.
 - **) Recommended tolerance of toolholder bore - H7.
- Balanced by design. For use above 3 000 rpm - we recommend individual balancing.

Accessories:

- Use preset Torque Wrench to ensure correct mounting of tools.
- 6 Nm - Part no. 19050
- 10 Nm - Part no. 19054



Digital Spirit Level

- For easy toolbar alignment use the ETP Digital Spirit Level
- Part no. 885010



Reduction Sleeves for ETP Clamping units



Reduction sleeve HS - for internal cooling

The reduction sleeves are designed to fit with the ETP clamping units. They are specially suited for high precision clamping of cylindrical tool shanks per DIN 6335 form HA, HB and HE, as well as tool shanks per DIN 1835 form B, C, D and E.

The special design of the reduction sleeves allows an efficient use of coolant through cutting tools.



Reduction sleeve HS-CF - for peripheral cooling.

Outer-Ø of reduction sleeve corresponds to the type.

- HS12 = Ø 12 mm
- HS20 = Ø 20 mm
- HS25 = Ø 25 mm
- HS32 = Ø 32 mm

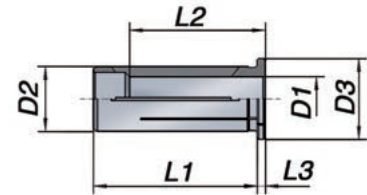

BENEFITS & FEATURES

- Standard version HS suited for internal cooling**
 Metal-to-metal seal for cutting tools with internal coolant channels.
- HS-CF version suited for peripheral cooling**
 The coolant flush reduction sleeves HS-CF can be used for peripheral cooling due to their coolant channels.
- Accurate precision**
 High runout accuracy < 3 µm.
- High flexibility**
 Clamping of different tool shank diameters. 12, 20, 25, 32 mm and 1/2", 3/4", 1", 1 1/4".
- Power increase**
 When using reduction sleeves the transmittable torque is increased.

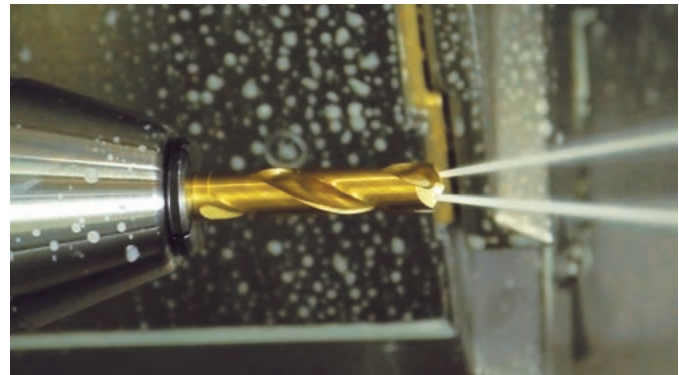

Using Reduction sleeve HS - for internal cooling.

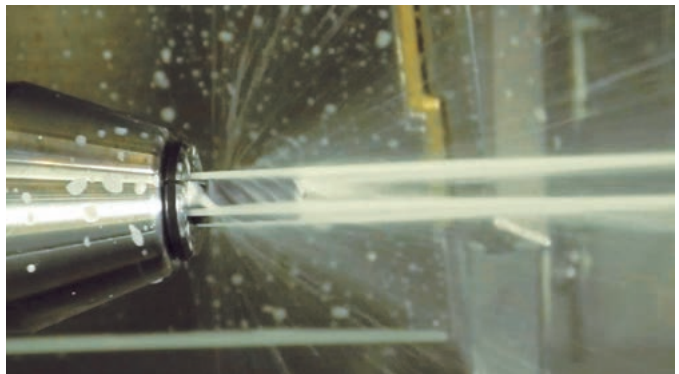

Using Reduction sleeve HS-CF - for peripheral cooling.

Reduction Sleeves Inch to inch

mm to inch

Reduction Sleeves inch to inch							
Part no.	Item description	D2 inch	D1 inch	D3 inch	L1 inch	L2 inch	L3 inch
Reduction Sleeves HS 1/2"							
● R1913.03182	HS 1/2" / 1/8"	0.500	0.1250	0.630	1.575	1.142	0.157
● R1913.04762	HS 1/2" / 3/16"	0.500	0.1875	0.630	1.575	1.142	0.157
● R1913.06352	HS 1/2" / 1/4"	0.500	0.2500	0.630	1.575	1.417	0.157
● R1913.07942	HS 1/2" / 5/16"	0.500	0.3125	0.630	1.575	1.457	0.157
● R1913.09522	HS 1/2" / 3/8"	0.500	0.3750	0.630	1.575	1.575	0.157
Reduction Sleeves HS 1/2"-CF							
● R1913.06353	HS 1/2"-CF / 1/4"	0.500	0.2500	0.630	1.575	1.417	0.157
● R1913.09523HS	1/2"-CF / 3/8"	0.500	0.3750	0.630	1.575	1.575	0.157
Reduction Sleeves HS 3/4"							
● R1919.03182	HS 3/4" / 1/8"	0.750	0.1250	0.984	1.969	1.102	0.157
● R1919.04762	HS 3/4" / 3/16"	0.750	0.1875	0.984	1.969	1.102	0.157
● R1919.06352	HS 3/4" / 1/4"	0.750	0.2500	0.984	1.969	1.417	0.157
● R1919.07942	HS 3/4" / 5/16"	0.750	0.3125	0.984	1.969	1.457	0.157
● R1919.09522	HS 3/4" / 3/8"	0.750	0.3750	0.984	1.969	1.417	0.157
● R1919.11112	HS 3/4" / 7/16"	0.750	0.4375	0.984	1.969	1.575	0.157
● R1919.12702	HS 3/4" / 1/2"	0.750	0.5000	0.984	1.969	1.772	0.157
● R1919.14292	HS 3/4" / 9/16"	0.750	0.5625	0.984	1.969	1.772	0.157
● R1919.15882	HS 3/4" / 5/8"	0.750	0.6250	0.984	1.969	1.890	0.157
Reduction Sleeves HS 3/4"-CF							
● R1919.06353	HS 3/4"-CF / 1/4"	0.750	0.2500	0.984	1.969	1.417	0.157
● R1919.09523	HS 3/4"-CF / 3/8"	0.750	0.3750	0.984	1.969	1.417	0.157
● R1919.12703	HS 3/4"-CF / 1/2"	0.750	0.5000	0.984	1.969	1.772	0.157
● R1919.15883	HS 3/4"-CF / 5/8"	0.750	0.6250	0.984	1.969	1.890	0.157
Reduction Sleeves HS 1"							
● R1926.03182	HS 1" / 1/8"	1.000	0.1250	1.181	2.205	1.142	0.157
○ R1926.04762	HS 1" / 3/16"	1.000	0.1875	1.181	2.205	1.142	0.157
● R1926.06352	HS 1" / 1/4"	1.000	0.2500	1.181	2.205	1.457	0.157
● R1926.07942	HS 1" / 5/16"	1.000	0.3125	1.181	2.205	1.457	0.157
● R1926.09522	HS 1" / 3/8"	1.000	0.3750	1.181	2.205	1.496	0.157
○ R1926.11112	HS 1" / 7/16"	1.000	0.4375	1.181	2.205	1.575	0.157
● R1926.12702	HS 1" / 1/2"	1.000	0.5000	1.181	2.205	1.811	0.157
○ R1926.14292	HS 1" / 9/16"	1.000	0.5625	1.181	2.205	1.850	0.157
● R1926.15882	HS 1" / 5/8"	1.000	0.6250	1.181	2.205	1.890	0.157
● R1926.17462	HS 1" / 11/16"	1.000	0.6875	1.181	2.205	1.890	0.157
● R1926.19052	HS 1" / 3/4"	1.000	0.7500	1.181	2.205	1.890	0.157
Reduction Sleeves HS 1"-CF							
● R1926.06353	HS 1"-CF / 1/4"	1.000	0.2500	1.181	2.205	1.457	0.157
● R1926.09523	HS 1"-CF / 3/8"	1.000	0.3750	1.181	2.205	1.496	0.157
● R1926.12703	HS 1"-CF / 1/2"	1.000	0.5000	1.181	2.205	1.811	0.157
● R1926.15883	HS 1"-CF / 5/8"	1.000	0.6250	1.181	2.205	1.890	0.157
● R1926.19053	HS 1"-CF / 3/4"	1.000	0.7500	1.181	2.205	1.890	0.157
Reduction Sleeves HS 1 1/4"							
○ R1931.04762	HS 1 1/4" / 3/16"	1.250	0.1875	1.417	2.362	1.142	0.157
○ R1931.06352	HS 1 1/4" / 1/4"	1.250	0.2500	1.417	2.362	1.417	0.157
○ R1931.07942	HS 1 1/4" / 5/16"	1.250	0.3125	1.417	2.362	1.417	0.157
● R1931.09522	HS 1 1/4" / 3/8"	1.250	0.3750	1.417	2.362	1.457	0.157
○ R1931.11112	HS 1 1/4" / 7/16"	1.250	0.4375	1.417	2.362	1.772	0.157
● R1931.12702	HS 1 1/4" / 1/2"	1.250	0.5000	1.417	2.362	1.772	0.157
○ R1931.14292	HS 1 1/4" / 9/16"	1.250	0.5625	1.417	2.362	1.811	0.157
● R1931.15882	HS 1 1/4" / 5/8"	1.250	0.6250	1.417	2.362	1.811	0.157
● R1931.17462	HS 1 1/4" / 11/16"	1.250	0.6875	1.417	2.362	1.890	0.157
● R1931.19052	HS 1 1/4" / 3/4"	1.250	0.7500	1.417	2.362	1.969	0.157
● R1931.25402	HS 1 1/4" / 1"	1.250	1.000	1.417	2.362	2.205	0.157
Reduction Sleeves HS 1 1/4"-CF							
● R1931.12703	HS 1 1/4"-CF / 1/2"	1.250	0.5000	1.417	2.362	1.772	0.157
● R1931.15883	HS 1 1/4"-CF / 5/8"	1.250	0.6250	1.417	2.362	1.811	0.157
● R1931.19053	HS 1 1/4"-CF / 3/4"	1.250	0.7500	1.417	2.362	1.969	0.157
● R1931.25403	HS 1 1/4"-CF / 1"	1.250	1.000	1.417	2.362	2.205	0.157

Reduction Sleeves mm to inch							
Part no.	Item description	D2 mm	D1 inch	D3 mm	L1 mm	L2 mm	L3 mm
Reduction Sleeves HS 12							
● R1912.03181	HS 12 / 1/8"	12	0.1250	16	40	29	4
● R1912.04761	HS 12 / 3/16"	12	0.1875	16	40	29	4
● R1912.06351	HS 12 / 1/4"	12	0.2500	16	40	29	4
● R1912.07941	HS 12 / 5/16"	12	0.3125	16	40	36	4
● R1912.09521	HS 12 / 3/8"	12	0.3750	16	40	37	4
Reduction Sleeves HS 20							
● R1920.03181	HS 20 / 1/8"	20	0.1250	25	50	28	4
● R1920.04761	HS 20 / 3/16"	20	0.1875	25	50	28	4
● R1920.06351	HS 20 / 1/4"	20	0.2500	25	50	36	4
● R1920.07941	HS 20 / 5/16"	20	0.3125	25	50	37	4
● R1920.09521	HS 20 / 3/8"	20	0.3750	25	50	36	4
● R1920.11111	HS 20 / 7/16"	20	0.4375	25	50	40	4
● R1920.12701	HS 20 / 1/2"	20	0.5000	25	50	45	4
● R1920.14291	HS 20 / 9/16"	20	0.5625	25	50	45	4
● R1920.15881	HS 20 / 5/8"	20	0.6250	25	50	48	4
Reduction Sleeves HS 25							
● R1925.03181	HS 25 / 1/8"	25	0.1250	30	56	29	4
○ R1925.04761	HS 25 / 3/16"	25	0.1875	30	56	29	4
● R1925.06351	HS 25 / 1/4"	25	0.2500	30	56	37	4
○ R1925.07941	HS 25 / 5/16"	25	0.3125	30	56	37	4
● R1925.09521	HS 25 / 3/8"	25	0.3750	30	56	38	4
○ R1925.11111	HS 25 / 7/16"	25	0.4375	30	56	40	4
● R1925.12701	HS 25 / 1/2"	25	0.5000	30	56	46	4
○ R1925.14291	HS 25 / 9/16"	25	0.5625	30	56	47	4
● R1925.15881	HS 25 / 5/8"	25	0.6250	30	56	48	4
○ R1925.17461	HS 25 / 11/16"	25	0.6875	30	56	48	4
● R1925.19051	HS 25 / 3/4"	25	0.7500	30	56	48	4
○ R1925.20631	HS 25 / 13/16"	25	0.8125	30	56	50	4
Reduction Sleeves HS 32							
○ R1932.04761	HS 32 / 3/16"	32	0.1875	36	60	29	4
○ R1932.06351	HS 32 / 1/4"	32	0.2500	36	60	36	4
○ R1932.07941	HS 32 / 5/16"	32	0.3125	36	60	36	4
● R1932.09521	HS 32 / 3/8"	32	0.3750	36	60	37	4
○ R1932.11111	HS 32 / 7/16"	32	0.4375	36	60	45	4
● R1932.12701	HS 32 / 1/2"	32	0.5000	36	60	45	4
○ R1932.14291	HS 32 / 9/16"	32	0.5625	36	60	46	4
● R1932.15881	HS 32 / 5/8"	32	0.6250	36	60	46	4
○ R1932.17461	HS 32 / 11/16"	32	0.6875	36	60	48	4
● R1932.19051	HS 32 / 3/4"	32	0.7500	36	60	50	4
○ R1932.20631	HS 32 / 13/16"	32	0.8125	36	60	50	4
● R1932.22221	HS 32 / 7/8"	32	0.8750	36	60	50	4
○ R1932.23811	HS 32 / 15/16"	32	0.9375	36	60	52	4
● R1932.25401	HS 32 / 1"	32	1.000	36	60	56	4

Reduction Sleeves

mm to mm

Reduction Sleeves mm to mm							
Part no.	Item description	D2 mm	D1 mm	D3 mm	L1 mm	L2 mm	L3 mm
Reduction Sleeves HS 12-MB (Micro Bore)							
○ R1912.01009	HS 12-MB / 1 mm	12	1.000	16	40	20	4
○ R1912.01509	HS 12-MB / 1,5 mm	12	1.500	16	40	20	4
○ R1912.02009	HS 12-MB / 2 mm	12	2.000	16	40	20	4
○ R1912.02509	HS 12-MB / 2,5 mm	12	2.500	16	40	20	4
Reduction Sleeves HS 12							
● R1912.03000	HS 12 / 3 mm	12	3.000	16	40	29	4
● R1912.04000	HS 12 / 4 mm	12	4.000	16	40	29	4
● R1912.05000	HS 12 / 5 mm	12	5.000	16	40	29	4
● R1912.06000	HS 12 / 6 mm	12	6.000	16	40	36	4
● R1912.07000	HS 12 / 7 mm	12	7.000	16	40	37	4
● R1912.08000	HS 12 / 8 mm	12	8.000	16	40	37	4
● R1912.09000	HS 12 / 9 mm	12	9.000	16	40	37	4
● R1912.10000	HS 12 / 10 mm	12	10.000	16	40	40	4
Reduction Sleeves HS 12-CF							
● R1912.03002	HS 12-CF / 3 mm	12	3.000	16	40	29	4
● R1912.04002	HS 12-CF / 4 mm	12	4.000	16	40	29	4
● R1912.05002	HS 12-CF / 5 mm	12	5.000	16	40	29	4
● R1912.06002	HS 12-CF / 6 mm	12	6.000	16	40	36	4
● R1912.08002	HS 12-CF / 8 mm	12	8.000	16	40	37	4
Reduction Sleeves HS 20							
● R1920.03000	HS 20 / 3 mm	20	3.000	25	50	28	4
● R1920.04000	HS 20 / 4 mm	20	4.000	25	50	28	4
● R1920.05000	HS 20 / 5 mm	20	5.000	25	50	28	4
● R1920.06000	HS 20 / 6 mm	20	6.000	25	50	36	4
● R1920.07000	HS 20 / 7 mm	20	7.000	25	50	38	4
● R1920.08000	HS 20 / 8 mm	20	8.000	25	50	37	4
● R1920.09000	HS 20 / 9 mm	20	9.000	25	50	38	4
● R1920.10000	HS 20 / 10 mm	20	10.000	25	50	40	4
● R1920.11000	HS 20 / 11 mm	20	11.000	25	50	40	4
● R1920.12000	HS 20 / 12 mm	20	12.000	25	50	45	4
● R1920.13000	HS 20 / 13 mm	20	13.000	25	50	45	4
● R1920.14000	HS 20 / 14 mm	20	14.000	25	50	45	4
● R1920.15000	HS 20 / 15 mm	20	15.000	25	50	45	4
● R1920.16000	HS 20 / 16 mm	20	16.000	25	50	48	4
● R1920.18000	HS 20 / 18 mm	20	18.000	25	50	48	4
Reduction Sleeves HS 20-CF							
○ R1920.03002	HS 20-CF / 3 mm	20	3.000	25	50	28	4
● R1920.04002	HS 20-CF / 4 mm	20	4.000	25	50	28	4
● R1920.05002	HS 20-CF / 5 mm	20	5.000	25	50	28	4
● R1920.06002	HS 20-CF / 6 mm	20	6.000	25	50	36	4
● R1920.08002	HS 20-CF / 8 mm	20	8.000	25	50	37	4
● R1920.10002	HS 20-CF / 10 mm	20	10.000	25	50	40	4
● R1920.12002	HS 20-CF / 12 mm	20	12.000	25	50	45	4
● R1920.14002	HS 20-CF / 14 mm	20	14.000	25	50	45	4
● R1920.16002	S 20-CF / 16 mm	20	16.000	25	50	48	4

Reduction Sleeves mm to mm							
Part no.	Item description	D2 mm	D1 mm	D3 mm	L1 mm	L2 mm	L3 mm
Reduction Sleeves HS 25							
● R1925.03000	HS 25 / 3 mm	25	3.000	30	56	29	4
● R1925.04000	HS 25 / 4 mm	25	4.000	30	56	29	4
● R1925.05000	HS 25 / 5 mm	25	5.000	30	56	29	4
● R1925.06000	HS 25 / 6 mm	25	6.000	30	56	37	4
● R1925.07000	HS 25 / 7 mm	25	7.000	30	56	37	4
● R1925.08000	HS 25 / 8 mm	25	8.000	30	56	37	4
● R1925.09000	HS 25 / 9 mm	25	9.000	30	56	38	4
● R1925.10000	HS 25 / 10 mm	25	10.000	30	56	40	4
● R1925.12000	HS 25 / 12 mm	25	12.000	30	56	46	4
● R1925.14000	HS 25 / 14 mm	25	14.000	30	56	47	4
● R1925.16000	HS 25 / 16 mm	25	16.000	30	56	48	4
● R1925.18000	HS 25 / 18 mm	25	18.000	30	56	48	4
● R1925.20000	HS 25 / 20 mm	25	20.000	30	56	50	4
Reduction Sleeves HS 32							
○ R1932.03000	HS 32 / 3 mm	32	3.000	36	60	29	4
○ R1932.04000	HS 32 / 4 mm	32	4.000	36	60	29	4
○ R1932.05000	HS 32 / 5 mm	32	5.000	36	60	29	4
● R1932.06000	HS 32 / 6 mm	32	6.000	36	60	36	4
● R1932.07000	HS 32 / 7 mm	32	7.000	36	60	37	4
● R1932.08000	HS 32 / 8 mm	32	8.000	36	60	36	4
● R1932.09000	HS 32 / 9 mm	32	9.000	36	60	37	4
● R1932.10000	HS 32 / 10 mm	32	10.000	36	60	40	4
○ R1932.11000	HS 32 / 11 mm	32	11.000	36	60	40	4
● R1932.12000	HS 32 / 12 mm	32	12.000	36	60	45	4
● R1932.13000	HS 32 / 13 mm	32	13.000	36	60	45	4
● R1932.14000	HS 32 / 14 mm	32	14.000	36	60	46	4
○ R1932.15000	HS 32 / 15 mm	32	15.000	36	60	46	4
● R1932.16000	HS 32 / 16 mm	32	16.000	36	60	48	4
○ R1932.17000	HS 32 / 17 mm	32	17.000	36	60	48	4
● R1932.18000	HS 32 / 18 mm	32	18.000	36	60	49	4
○ R1932.19000	HS 32 / 19 mm	32	19.000	36	60	49	4
● R1932.20000	HS 32 / 20 mm	32	20.000	36	60	50	4
● R1932.22000	HS 32 / 22 mm	32	22.000	36	60	50	4
● R1932.25000	HS 32 / 25 mm	32	25.000	36	60	56	4
Reduction Sleeves HS 32-CF							
○ R1932.06002	HS 32-CF / 6 mm	32	6.000	36	60	36	4
○ R1932.08002	HS 32-CF / 8 mm	32	8.000	36	60	36	4
○ R1932.10002	HS 32-CF / 10 mm	32	10.000	36	60	40	4
○ R1932.12002	HS 32-CF / 12 mm	32	12.000	36	60	45	4
○ R1932.14002	HS 32-CF / 14 mm	32	14.000	36	60	46	4
○ R1932.16002	HS 32-CF / 16 mm	32	16.000	36	60	48	4
○ R1932.18002	HS 32-CF / 18 mm	32	18.000	36	60	49	4
○ R1932.20002	HS 32-CF / 20 mm	32	20.000	36	60	50	4
○ R1932.25002	HS 32-CF / 25 mm	32	25.000	36	60	56	4

Accessories

Torque wrench and Extractor



Comparison of Transmittable Torque at Ø 20 mm

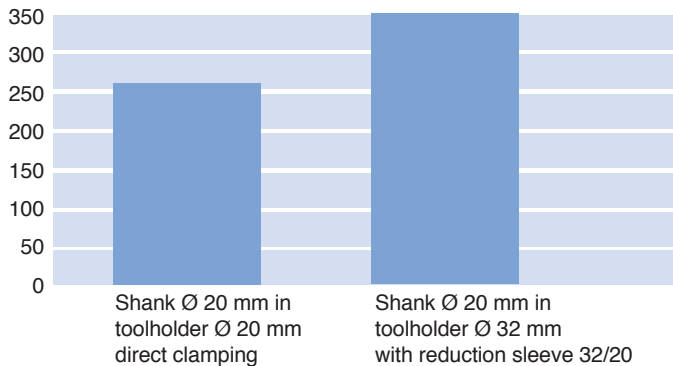

Torque wrench

Use torque wrench to ensure correct tightening independent on user. Should be used with all HYDRO-FIX® holders.

Item description	Tightening torque:		Part no.
	Nm	ft · lb	
• Torque wrench (4 mm Hex)	6	4.4	19055
• Torque wrench (5 mm Hex)	6	4.4	19050
• Torque wrench (8 mm Hex)	10	7.4	19054

Extractor

Item description	Part no.	For Sizes	A [mm]	B [mm]
• EHS 12 - 1/2"	E7321.12000	HS 12	24.6	100
• EHS 20 - 3/4"	E7321.20000	HS 20	38.0	160
• EHS 25 - 1"	E7321.25000	HS 25	51.0	180
• EHS 32 - 1 1/4"	E7321.32000	HS 32	63.0	200

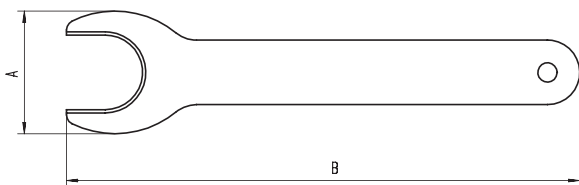

The extractor helps to remove the reduction sleeve from the clamping unit.

- Improper assembly can damage the concentricity of the reduction sleeve.
- Insert tools the full length of the reduction sleeve.
- Tool shank h6 or h7 can be used.
- Do not clamp reduction sleeve without a tool. Reduction Sleeve will be damaged.

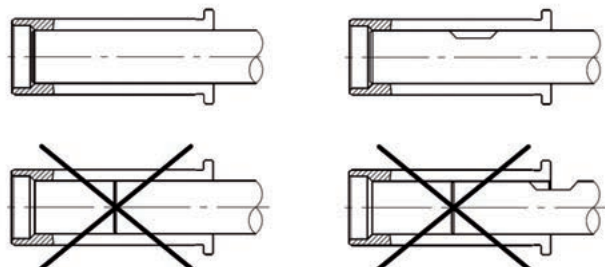



More Hydraulic high precision toolholders - see our main catalogue



Examples: Holders for rotary transfer machines

ETP HYDRO-GRIP®
HSK Form C - DIN 69893



ETP HYDRO-GRIP®
HSK Form C - For HYDROMAT®



**COMPLETE
METALWORKING
SOLUTIONS**

(800) 991-4225
www.ahbinc.com
ISO Certified
customerservice@ahbinc.com