

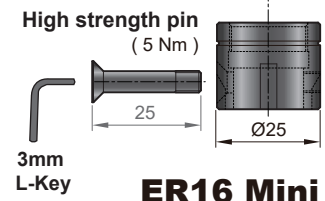

99816 System

Ergo system can apply on live spindle tool of turning centers and swiss type automatic lathes such as Star, Citizen, Tsugami, Doosan, Tornos, INDEX, EMAG...and so on.

Tool length setter
99816-ER16-LS6-M19
99816-ER16-LS6-M22



ER16 Mini Nut (30 Nm)
99816-ER16-M19
(Supplied with pin & key.)

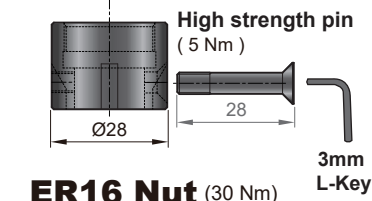

ER16 Nut (30 Nm)
99816-ER16-M22
(Supplied with pin & key.)



Open spanner
99816-SP28

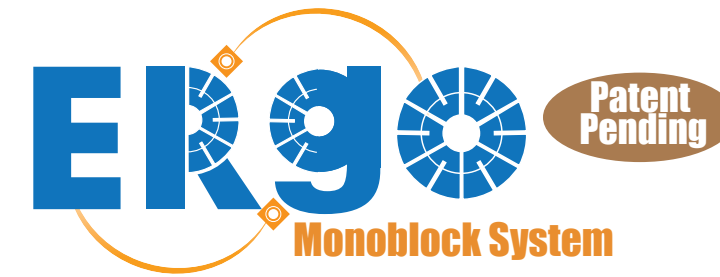

Apply for Swiss Type Automatic Lathe & CNC Turning Centers

Center coolant / Pre-balanced

- Better rigidity
- Tool size benefit
- Ultrashort tool length
- Minimize tool setting time

NC Spot Drill

G6.3 10000 r.p.m

Engraving Tool

G4.0 20000 r.p.m

Chamfer Mill

G6.3 10000 r.p.m

Power Mill

Center Coolant / G6.3 10000 r.p.m

i-Center

Center Coolant
G6.3 10000 r.p.m

Boring Tool

99816-09V 99816-606 99816-610 99816-614 99816-X060 99816-V045 99816-V060 99816-C10 99816-10A06 / 12A06 / 16A06 / 20A06 / 25A06 / 32A06 99816-IC10 On Request

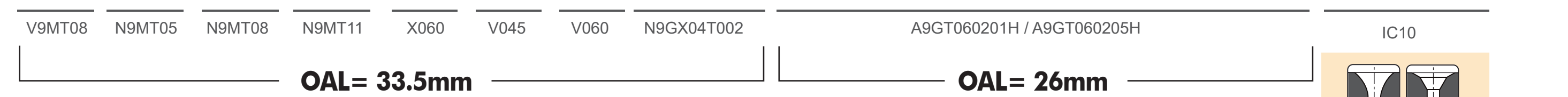
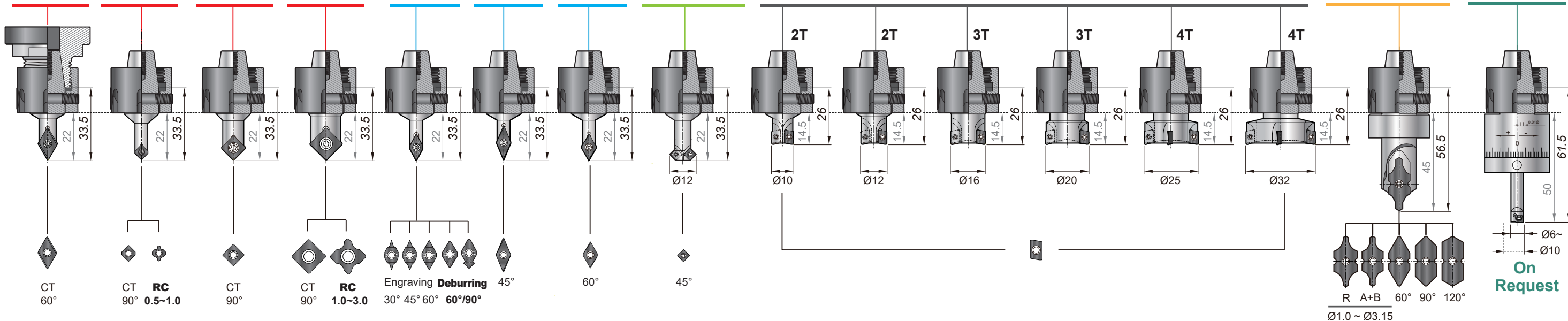

*Subject to change without notice. Copyright© Immore International Corp. All rights reserved. 201910



2019~2020

EVEREDE TOOL COMPANY
850 West Hawthorne Lane
West Chicago, Illinois 60185
331-871-5214
www.everede.net

Agent



ERgo just say “ergo”.
 The ERgo is a new trademark of Nine9 for ER style collet system.
 ERgo provides quick change capabilities,
 a unique tooling system for Swiss type automatic lathe,
 live spindle tool of CNC turning centers.

Concept:
Patent pending!
“ A simple way to maximize clamping force”

An integrated ER taper- shank cutter, eliminate assembly tolerance
 A clamping force from the 3 parts including ERgo nut,
 high strength pin and ER taper when ERgo nut drives the pin to push
 ERgo holder into ER taper.
 * ERgo nut: M19 ERgo mini nut / clamping torque: 30 Nm.
 M22 ERgo nut / clamping torque: 30 Nm.
 * Pin clamping torque: 5 Nm.

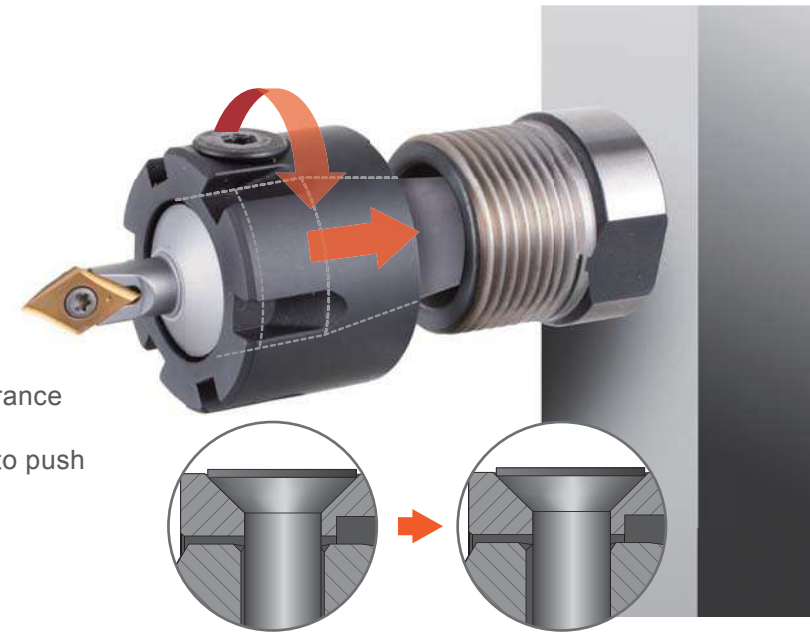

Inserts >> Quick Pick

Nine9 inserts apply for modern machining by its special geometry which is able to run at higher speed and feed rate. In addition, the indexable insert eliminates the tool's changing time. Carbide insert with latest coating technology extends tool life dramatically. Nine9-insert helps you to save money and increase productivity.

Products		Grade	Coating	P Steel	M Stainless Steel	K Cast Iron	N Non- Ferrous
NC Spot Drill	Spotting Ø1 ~ Ø14	NC10	TiAlN		●	●	⊙
		NC40	TiN	●	○	⊙	
		NC2071	TiN	●	⊙	●	⊙
		NC9076	DLC		⊙		●
Corner Rounding	R 0.5 ~ R 3.0	NC2071	TiN	●	○	●	
		NC9036	DLC		●		●
i-Center	Pilot Ø1.0 ~ Ø3.15	NC2057	ALL	●	○	⊙	○
V045 / V060 Engraving	Width 0.45 ~ 2.7	NC2032	TiAlN	●	○	●	
		NC2071	TiN	⊙	●		⊙
		NC9031	TiN		⊙		●
X060 Engraving	Width 0.2 ~ 1.39	NC2032	TiAlN	●	○	●	
		XP9001	Polished				●
NC Deburring	Width 0.3 ~ 3.5	NC2032	TiAlN	●	○	⊙	●
Chamfer Mill	Chamfering Ø7 ~ Ø11	NC2032	AlTiN	●	○	●	
		NC9071	TiN	○	●		●
Power mill	Cutter Ø10 ~ Ø32	NC5072	AlCrN	●	⊙	●	
		NC2033	TiAlN	●	⊙	●	
		NC9031	TiN				●
Boring Tool	Ø6 ~ Ø10	NC30	TiAlN	●	⊙	●	

● Best ⊙ Suit ○ Possible

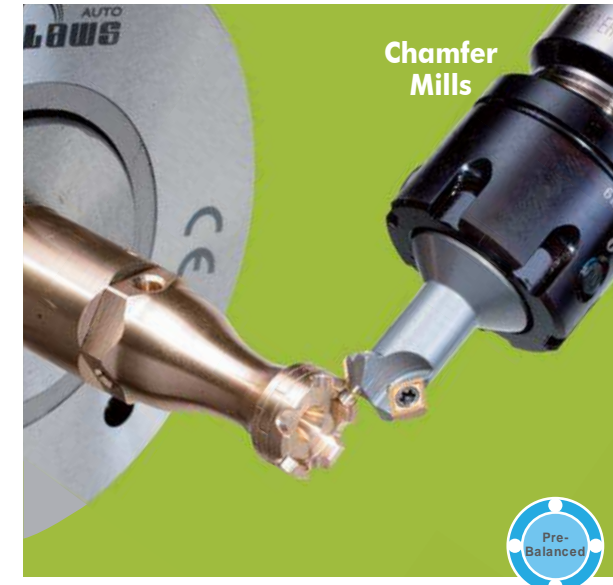
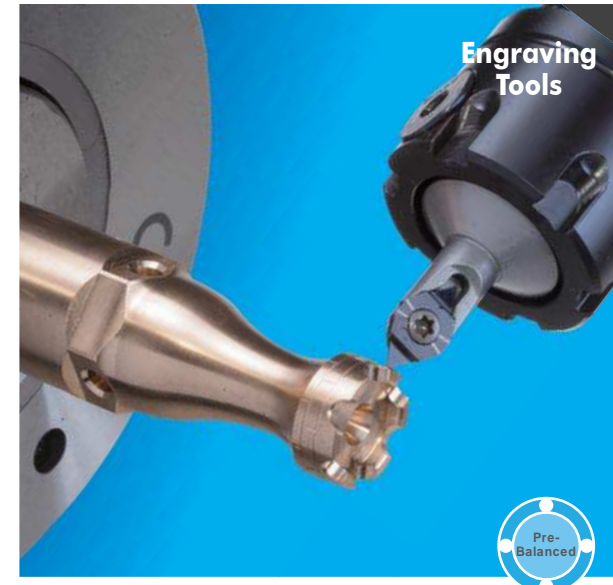

Tool size benefits

- Ultrashort tool length fits in a limited space.
- ERgo ER16 tool has milling cutter range from 10 to 32mm. Dimension of milling cutter is not limited by the ER16 collet clamping range.

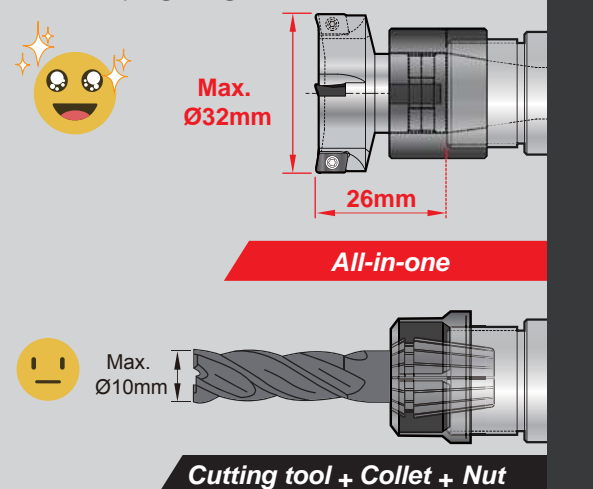

Easy adopt, simple and quick change

- ERgo tool provides an assembled set, changing tool takes just few seconds.
- Thanks to ER taper, when change same tool length tool, the tolerance is ±0.1mm.
- For the first time you can use **ERgo tool length setter** for checking the datum position.



Excellent repeatability, saving change time

- Indexable insert provide the greatest benefit of saving tool changing time and tool length setting time.

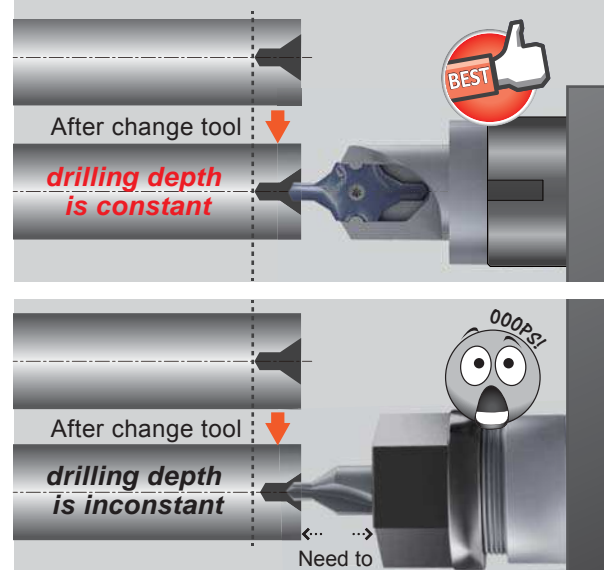

Increase tool rigidity and tool life

- The center coolant directed at the cutting edge.
- Pre-balanced tool, ready for high speed machining.
- Increase tool life 3 ~ 5 times is possible.

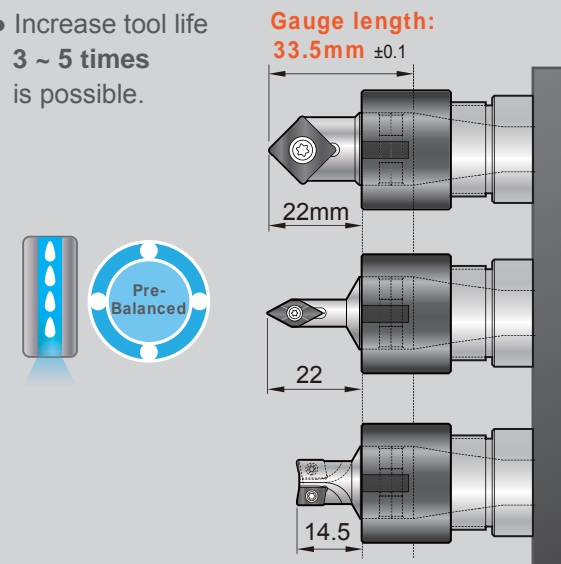

Tool length setter for your option

“ Simple tool length setting ”
 A easy tool length recorder while setting the tool length either on swiss type automatic lathe or CNC turning centers.

