

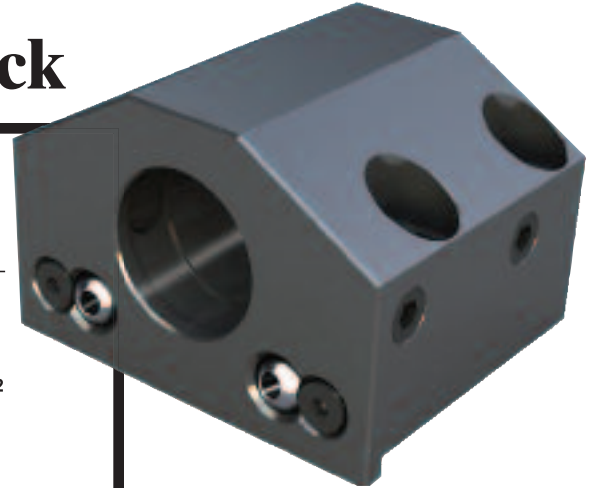

# Okuma Style Boring Bar Holder; ID Tool Block

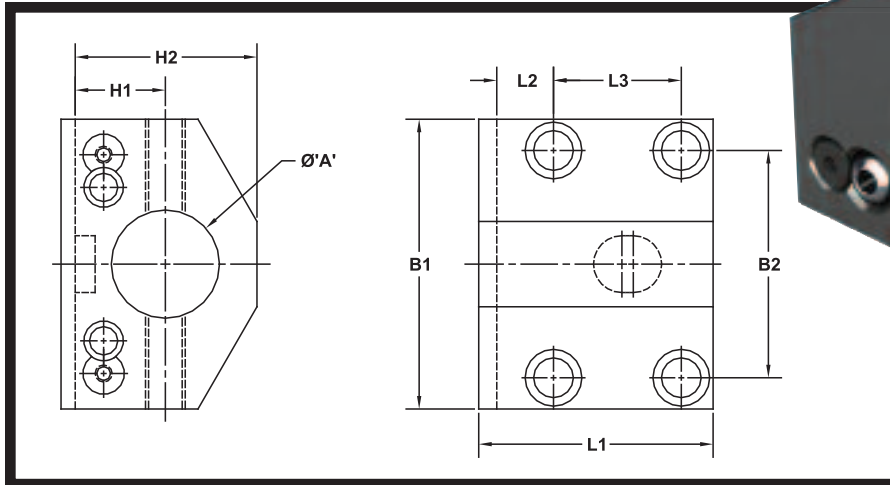

PART NUMBER	A	H1	H2 <sub>1</sub>	L1	L2	L3	B1	B2
CNC LB15-8435	1 1/2"	31.7	63	82.6	20	45	102	80
CNC LB15-8032	40MM	30	63	82.6	20	45	102	80
CNC LB15-8436	2"	34.9	66	82.6	20	45	102	80
CNC LB35-8436	2"	34.9	72	124	25	70	116	85
CNC LB45-8437	2 1/2"	41.3	90	126	25	70	134	105

# Okuma Style Turning Toolholder OD Tool Block

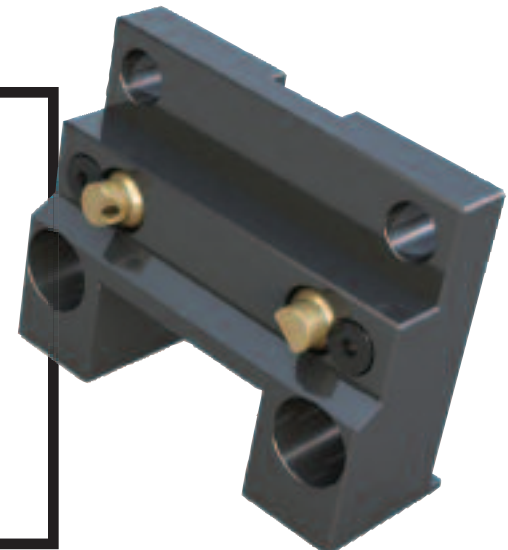
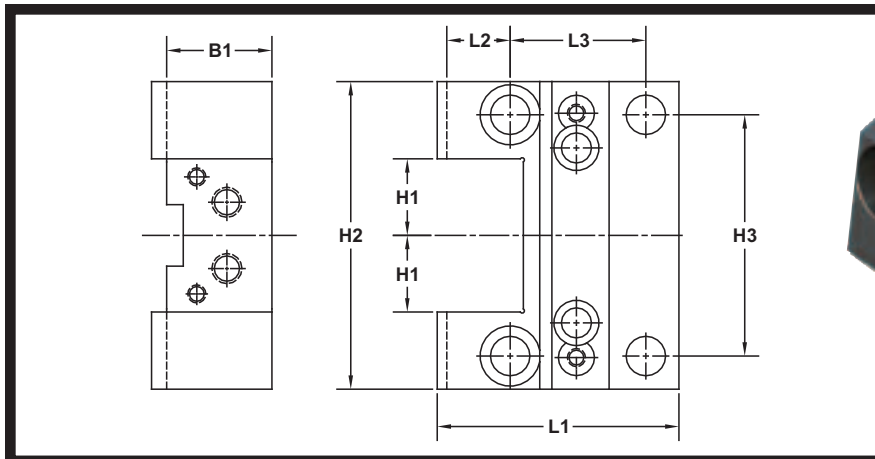

PART NUMBER	H1	H2	H3	L1	L2	L3	B1
CNC LB15-8007	25MM	102	80	80.2	20	45	35
CNC LB15-8212	1"	102	80	80.2	20	45	35
CNC LB15-8410	1"	102	80	82.6	20	45	35
CNC LB35-8212	1"	116	85	123.2	25	70	50.8
CNC LB45-8212	1 1/4"	134	105	123.2	25	70	69.8

**Global CNC Manufactures Tool Blocks for All Machines!**



# Okuma Style Square Toolholder OD Tool Block

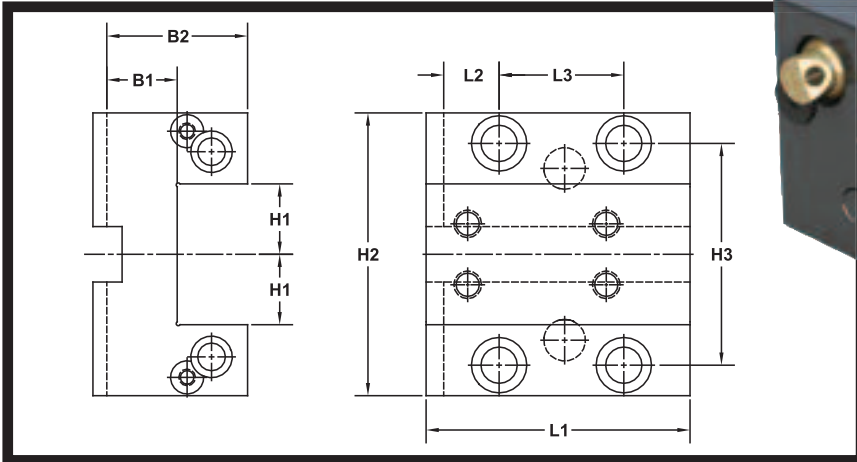

PART NUMBER	H1	H2	H3	L1	L2	L3	B1	B2
CNC LB15-8213	1 1/2"	102	80	82.6	20	45	25.4	50.8
CNC LB15-8008	25MM	102	80	83	20	45	25	50
CNC LB15-8411	1"	102	80	95.2	20	45	25.4	50.8
CNC LB35-8411	1"	116	85	123.8	25	70	25.4	50.8
CNC LB45-8411	1 1/4"	134	105	126	25	70	28.6	60

# HAAS Style ID Tool Block

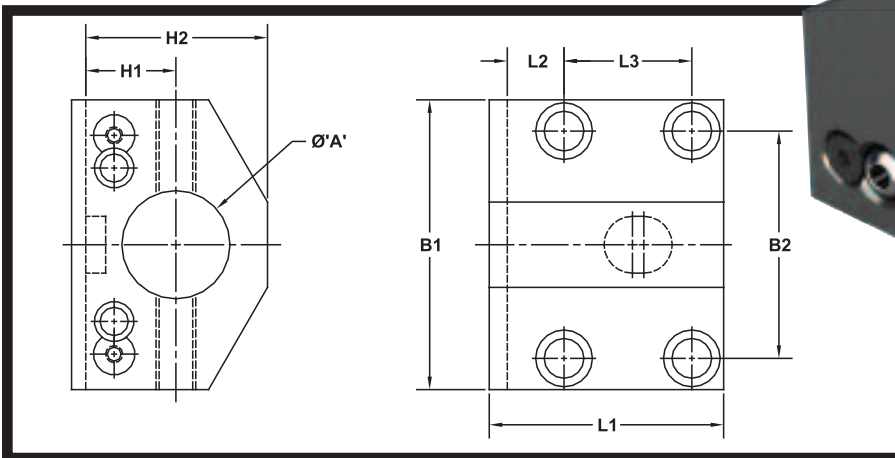
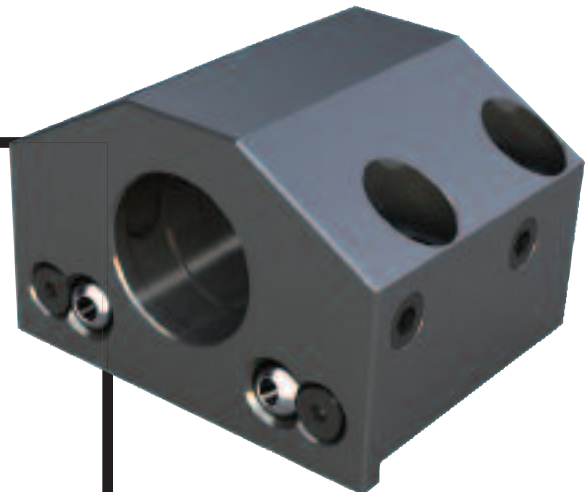

PART NUMBER	A	H1	H2	L1	L2	L3	B1	B2
CNC HSL10-8425	1"	25.4	50	77	15	45	90	70
CNC HSL10-8432	1 1/4"	25.4	50	77	15	45	90	70
CNC HSL20/30-8425	1"	31.8	65	82.6	20	45	102	80
CNC HSL20/30-8432	1 1/4"	31.8	65	82.6	20	45	102	80
CNC HSL20/30-8435	1 1/2"	31.8	65	82.6	20	45	102	80
CNC HSL40-8436	2"	41.3	90	122	25	70	134	105
CNC HSL40-8437	2 1/2"	41.3	90	122	25	70	134	105

**Global CNC Manufactures Tool Blocks for All Machines!**



Superior Design/Premium Quality



TOOL BLOCKS



# HAAS Style OD Tool Block

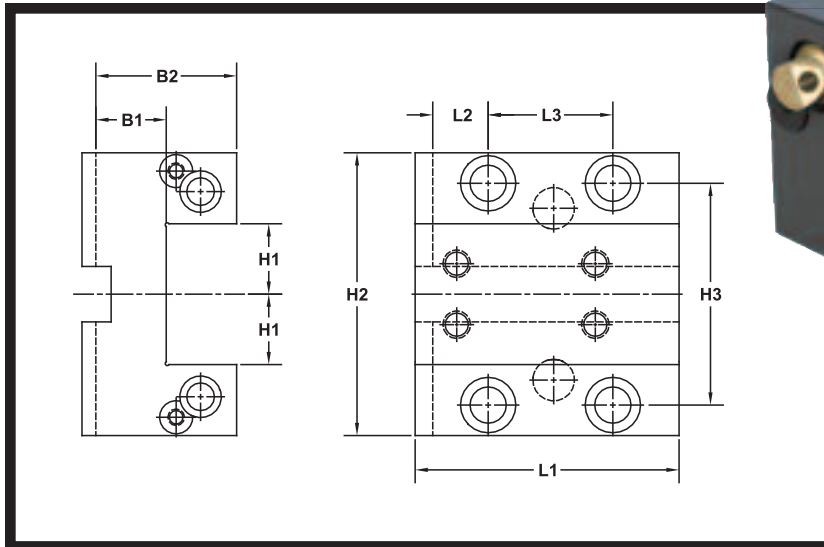

PART NUMBER	H1	H2	H3	L1	L2	L3	B1	B2
CNC HSL10-8411	3/4"	90	70	77	15	45	19	38.1
CNC HSL20/30-8411	1"	102	80	82.6	20	45	25.4	55.9
CNC HSL40-84111	1 1/4"	134	105	123	25	70	30.5	60

# MORI SEIKI Style ID Tool Block

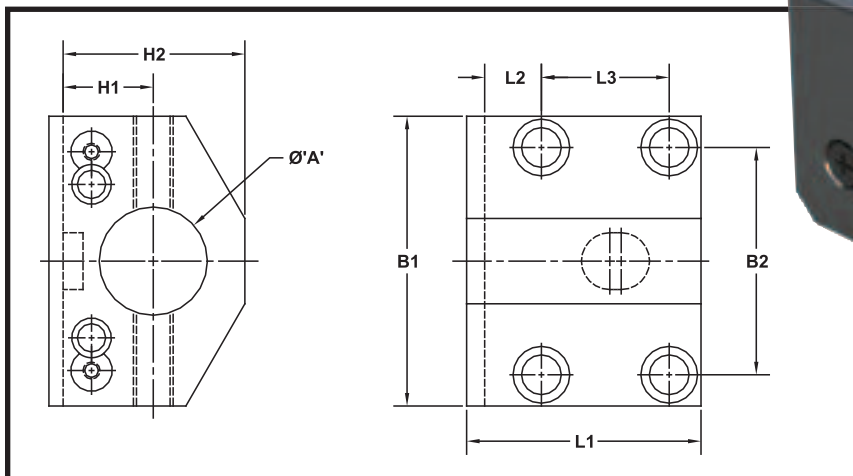

PART NUMBER	A	H1	H2	L1	L2	L3	B1	B2
CNC MSL20/30-8435	1-1/2"	400	73	90	20	35	106	76
CNC MSL25-8436	2"	40	85	113	27	63	118	88
CNC NL3000-8435	1-1/2"	80	120	18	94	135	108	84
CNC NL3000-8436	2"	80	120	18	94	135	108	84

TOOL BLOCKS





# MORI SEIKI Style OD Tool Block

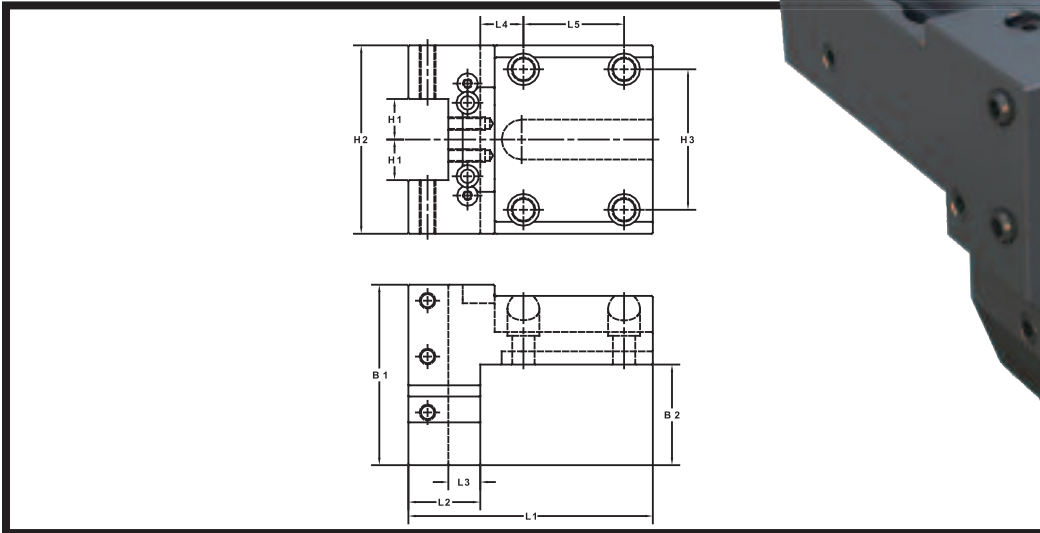

PART NUMBER	H1	L1	L2	L3	L4	L5	H2	H3	B	B2
CNC MSL20/30-8212	1"	153	70	45	20	35	106	76	90	50
CNC MSL25-8212	1"	153	45	20	27	63	118	88	113	63

# ROMI Style ID Tool Block

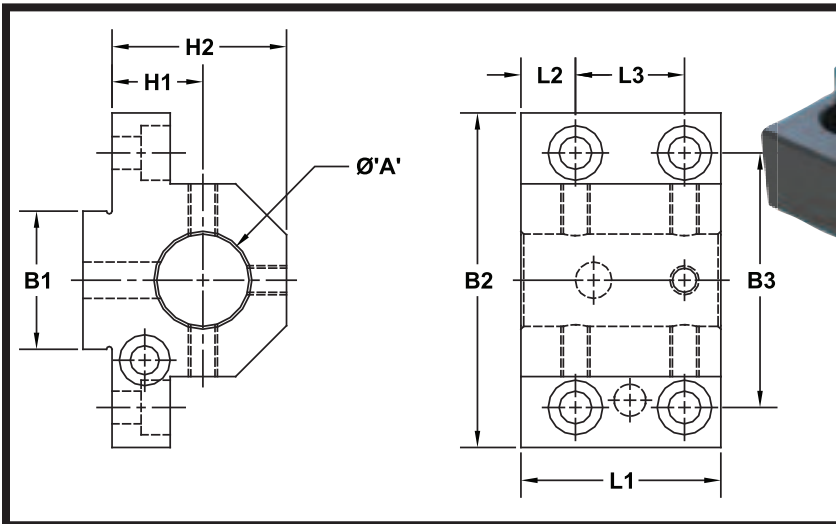
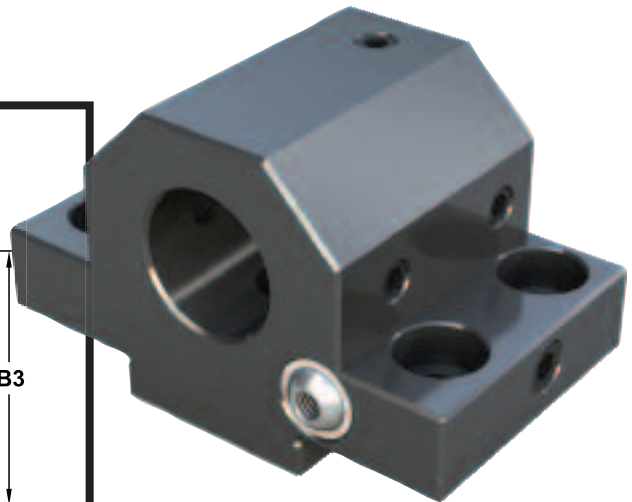

PART NUMBER	A	H1	H2	L1	L2	L3	B1	B2	B3
CNC ROM-86804M17	1"	25	48	55	15	30	38	92	70

TOOL BLOCKS





# ROMI Style ID Tool Block

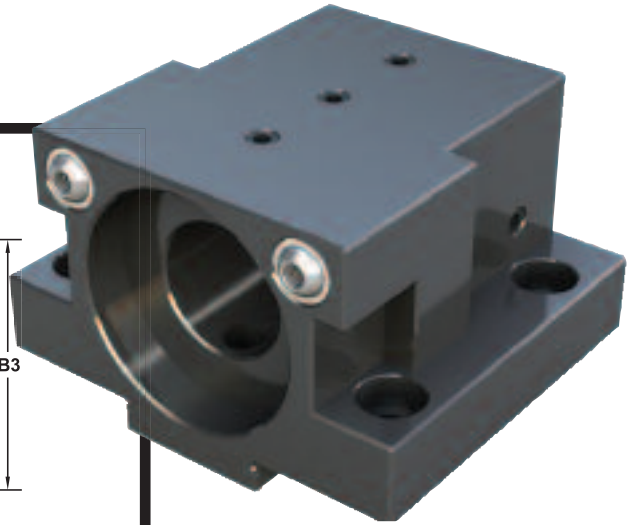
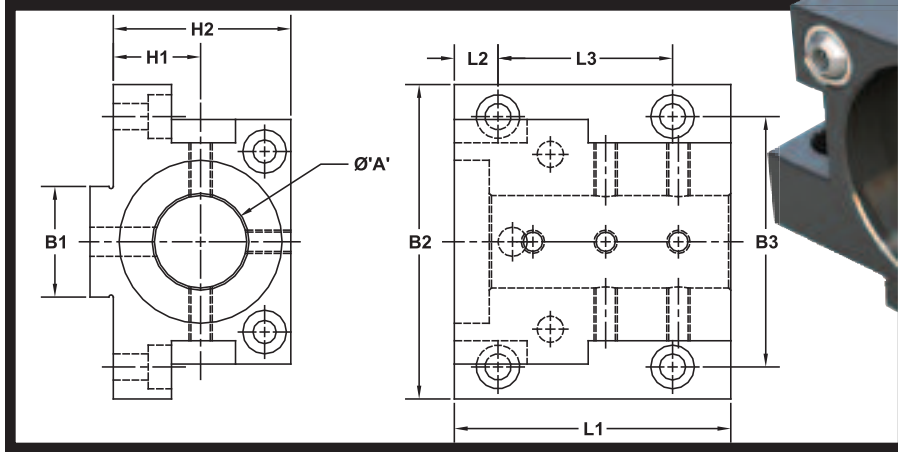

PART NUMBER	A	H1	H2	L1	L2	L3	B1	B2	B3
CNC ROM-21171M20	1.25"	30	61	95	15	60	38	108	86

# ROMI Style ID Tool Block

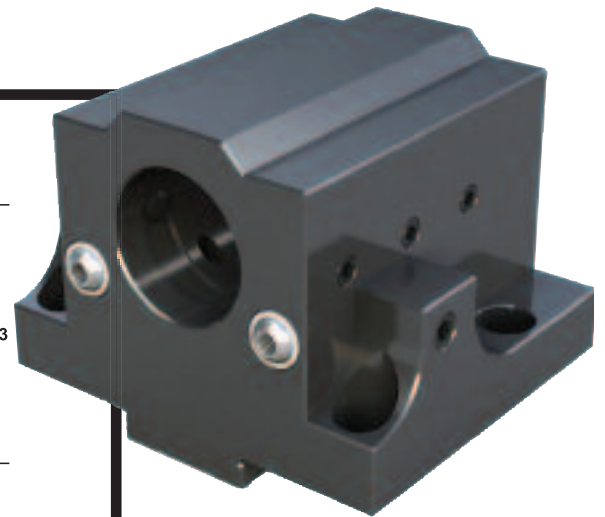
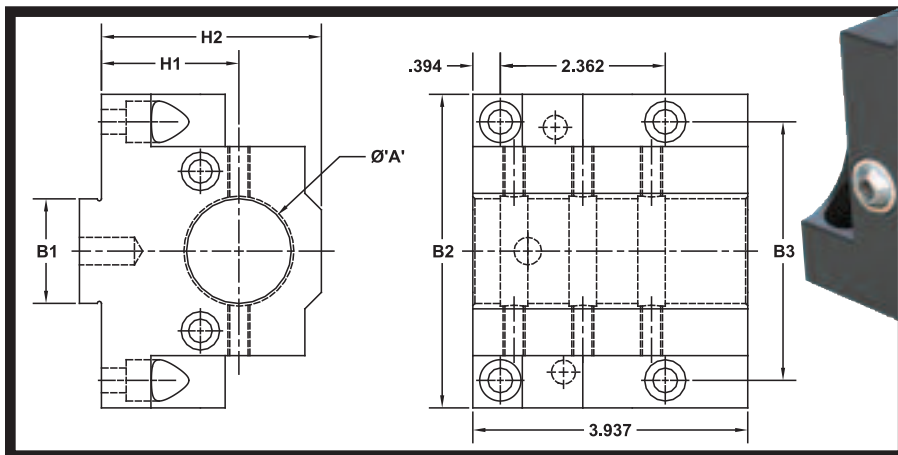

PART NUMBER	A	H1	H2	L1	L2	L3	B1	B2	B3
CNC ROM-83582M27	1-1/2"	50	80	90	20	35	38	114	94

TOOL BLOCKS





# OKUMA HOWA Style ID Tool Block

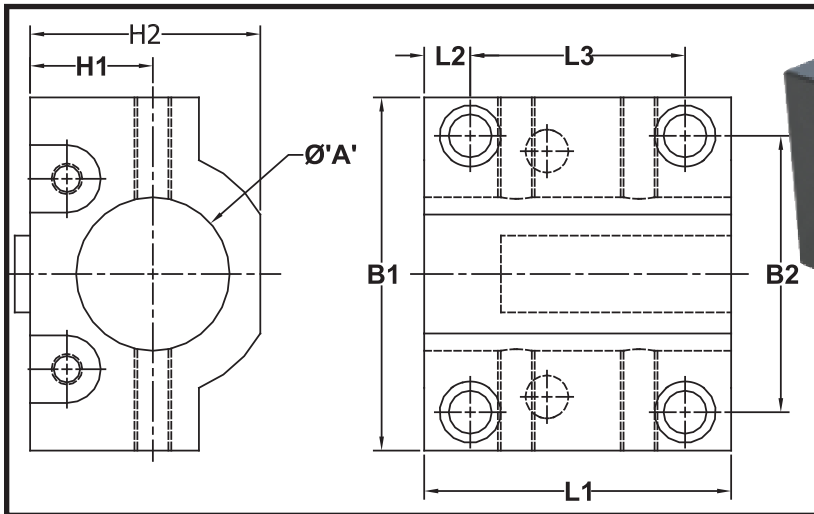

PART NUMBER	A	H1	H2	L1	L2	L3	B1	B2
CNC OHB4A-8435	1 1/2"	40	75	100	15	70	115	90
CNC OHB4A-8436	2"	40	75	100	15	70	115	90
CNC OHB6B-8435	1 1/2"	65	100	90	15	50	105	80
CNC OHB6B-8436	2"	65	100	90	15	50	105	80

# OKUMA HOWA Style OD Tool Block

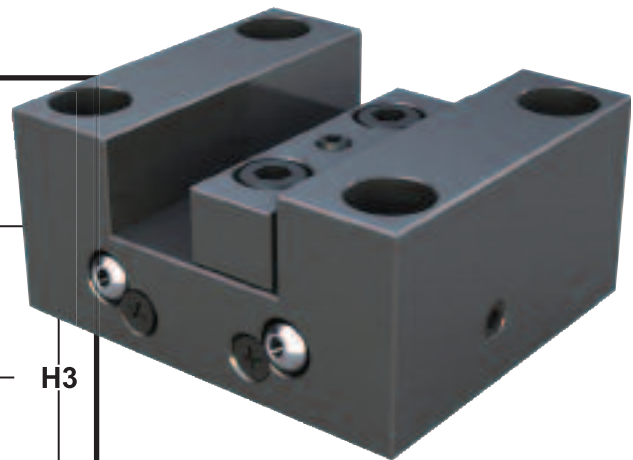
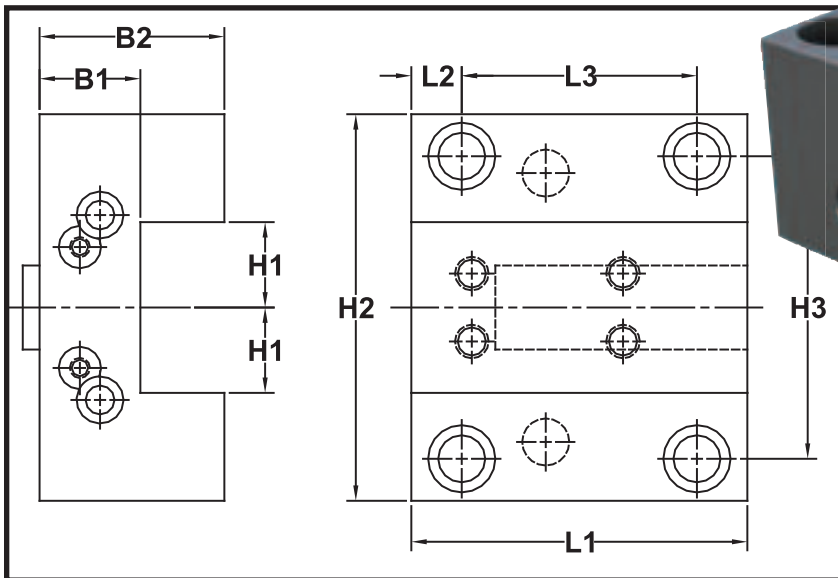

PART NUMBER	H1	H2	H3	L1	L2	L3	B1	B2
CNC OHF4A-8411	1"	115	90	100	15	70	30	55
CNC OHF6B-8611	1"	105	80	80	15	50	40	65

TOOL BLOCKS





# MAZAK Style ID Tool Block

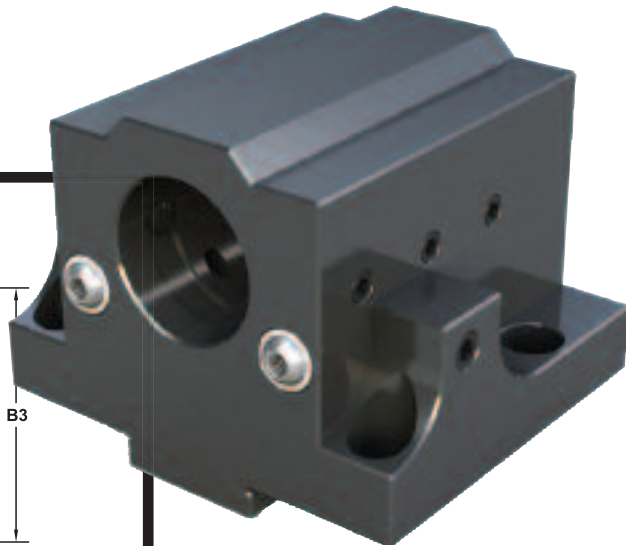
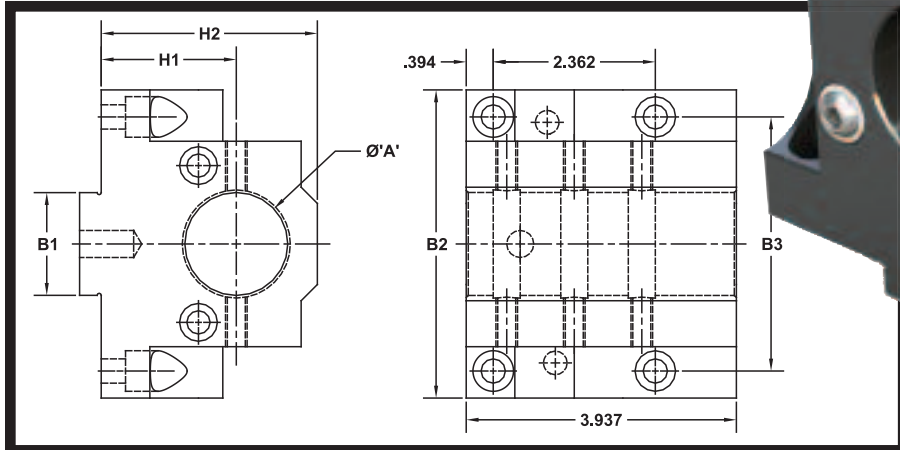

PART NUMBER	A	H1	H2	L1	L2	L3	B1	B2	B3
CNC NEX200/350-8435	1-1/2"	50	80	90	20	35	38	114	94

# MAZAK Style ID Tool Block

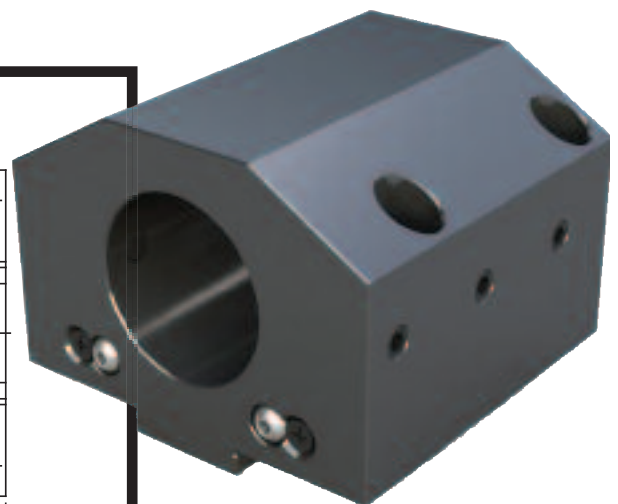
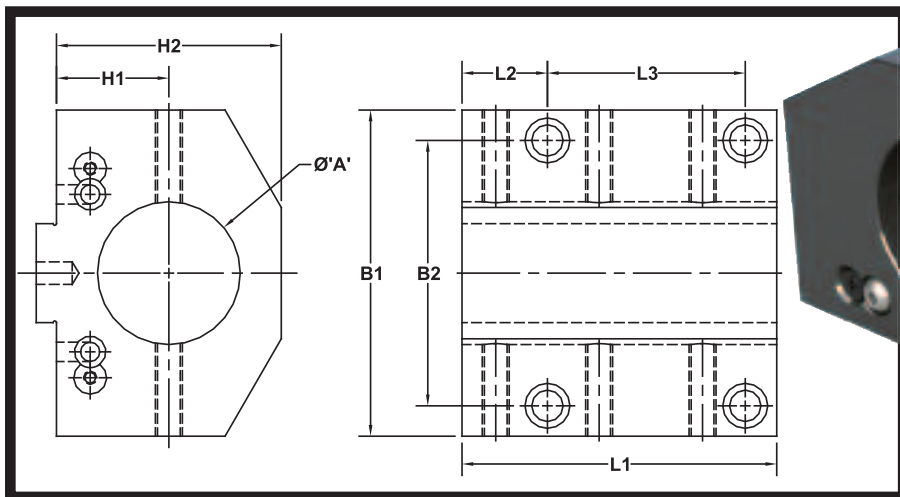

PART NUMBER	A	H1	H2	L1	L2	L3	B1	B2
CNC NEX450-8435	2-1/2"	50	100	140	38	88	124	118

TOOL BLOCKS

