

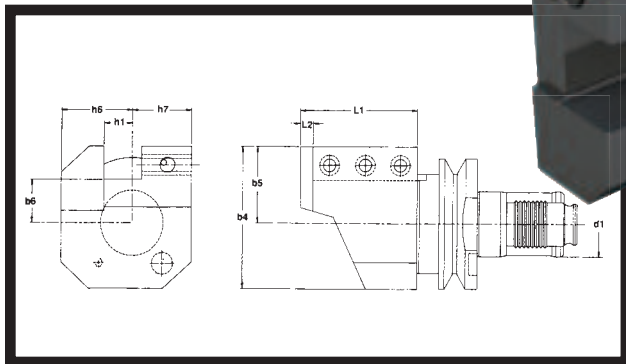

# Mazak Integrex Style Turning Toolholder

Right-Hand & Left-Hand –  
Form MC1 & MC2

For Mazak Integrex 50Y  
and 70Y Machines

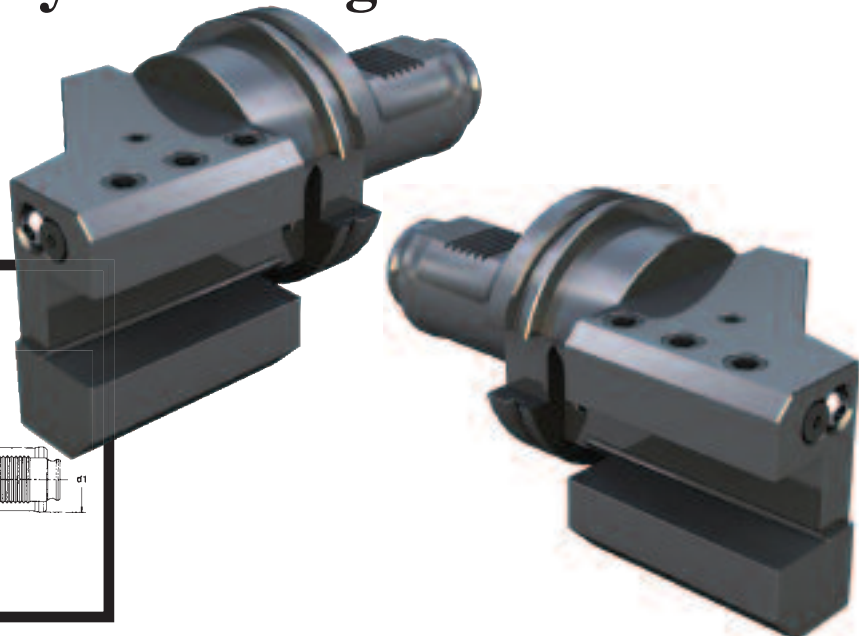

PART NUMBER	d <sub>1</sub>	b <sub>4</sub>	b <sub>5</sub>	b <sub>6</sub>	h <sub>1</sub>	h <sub>6</sub>	h <sub>7</sub>	L <sub>1</sub>	L <sub>2</sub>
CNC86 M31.5025R (Top)	50	107	57	31.8	1	50	29	135	10
CNC86 M31.6032R (Top)	60	122	72	40	1¼	56	335	155	10
CNC86 M32.5025L (Bottom)	50	107	57	31.8	1	50	29	135	10
CNC86 M32.6032L (Bottom)	60	122	72	40	1¼	56	335	155	10

# Mazak Integrex Style Turning Toolholder

Inverted – Form MC3  
& MC4

For Mazak Integrex 50Y  
and 70Y Machines

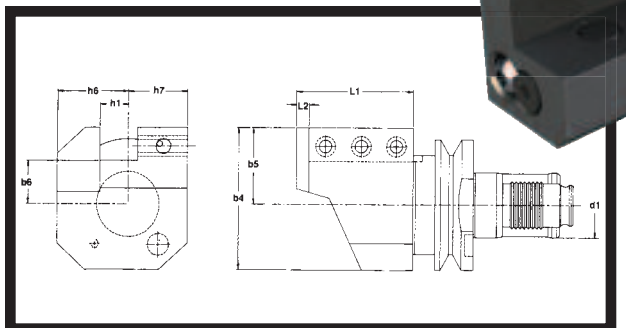

PART NUMBER	d <sub>1</sub>	b <sub>4</sub>	b <sub>5</sub>	b <sub>6</sub>	h <sub>1</sub>	h <sub>6</sub>	h <sub>7</sub>	L <sub>1</sub>	L <sub>2</sub>
CNC86 M33.5025R (Top)	50	107	57	31.8	1	50	29	135	10
CNC86 M33.6032R (Top)	60	122	72	40	1¼	56	335	155	10
CNC86 M34.5025L (Bottom)	50	107	57	31.8	1	50	29	135	10
CNC86 M34.6032L (Bottom)	60	122	72	40	1¼	56	335	155	10

Please note: All Standard VDI from "B" section available in MZK Style for Mazak Machines.





# Mazak Integrex Style Boring Bar Holder

Single External Coolant Flow –  
Form ME4

For Mazak Integrex 50Y and 70Y Machines

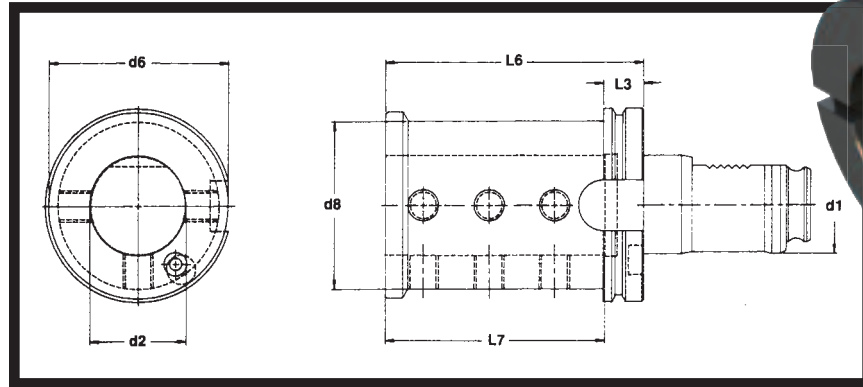

PART NUMBER	d <sub>1</sub>	d <sub>2</sub>	d <sub>6</sub>	d <sub>8</sub>	L <sub>3</sub>	L <sub>6</sub>	L <sub>7</sub>
CNC86 M54.5050	50	2	95.5	85	21	135	115
CNC86 M54.6050	60	2	120	98	25	128	112

# Mazak Integrex Style Collet Chuck

ER32 or TG100 – Form ME3

For Mazak Integrex 50Y and 70Y Machines

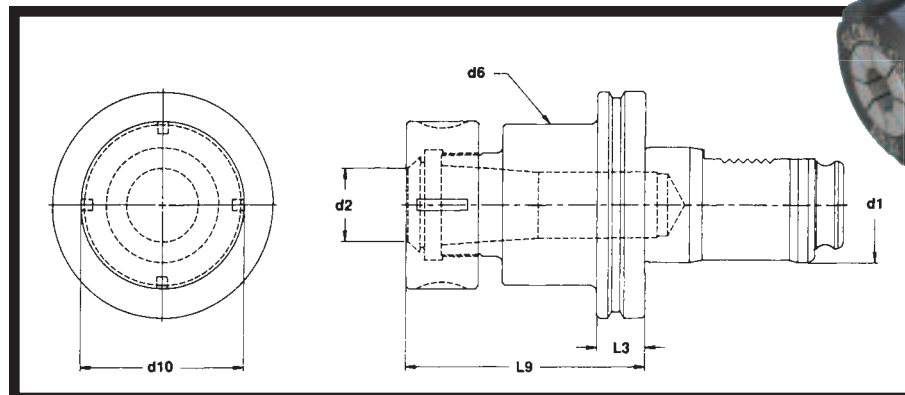

PART NUMBER	d <sub>1</sub>	COLLET	d <sub>2</sub>	d <sub>6</sub>	d <sub>10</sub>	L <sub>3</sub>	L <sub>9</sub>
CNC86 M53.5032	50	ER32	2-20	70	50	21	106.5
CNC86 M53.6032	60	ER32	2-20	70	50	21	106.5
CNC86 M53.50100TG	50	100TG	2-25	70	60	21	112
CNC86 M53.60100TG	60	100TG	2-25	70	60	32	112

Please note: All Standard VDI from "B" section available in MZK Style for Mazak Machines.

MAZAK





# Mazak SQT Style Forward Turning Toolholder

3/4" or 1" OD Holder  
Form SQT-C1

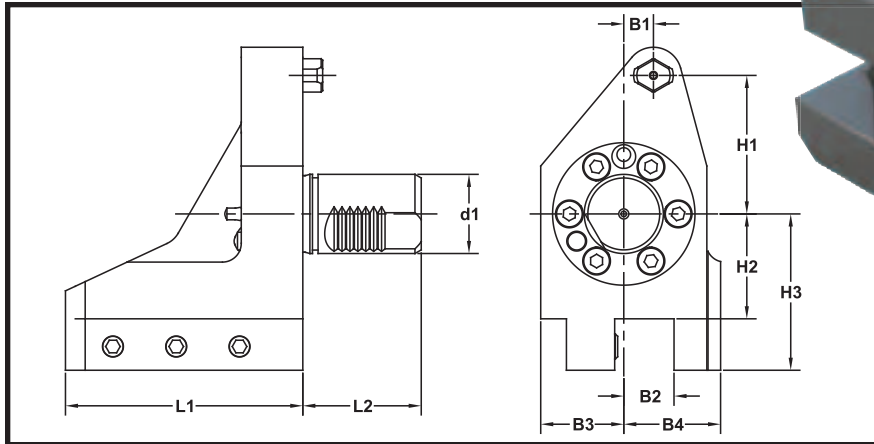
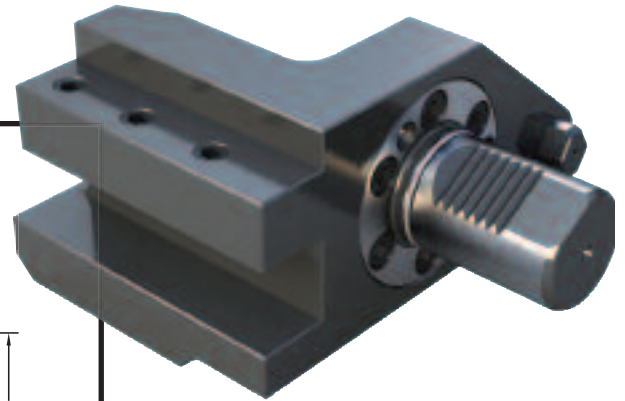

PART NUMBER	D1	B1	B2	B3	B4	L1	L2	H1	H2	H3
SQT31.1020	40	15	20	38	41	100	60	68	45	65
SQT31.1525	40	15	25	42	50	120	60	70	53	79

# Mazak SQT Style Reverse Turning Toolholder

3/4" or 1" OD Holder  
Form SQT-C2

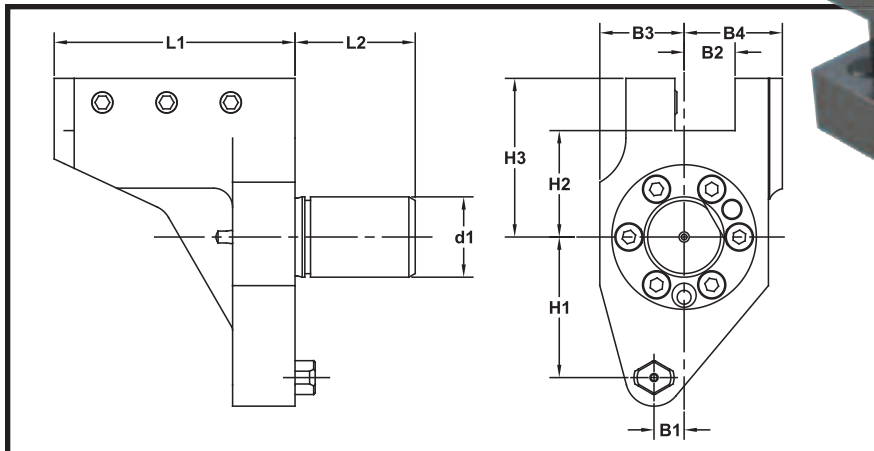
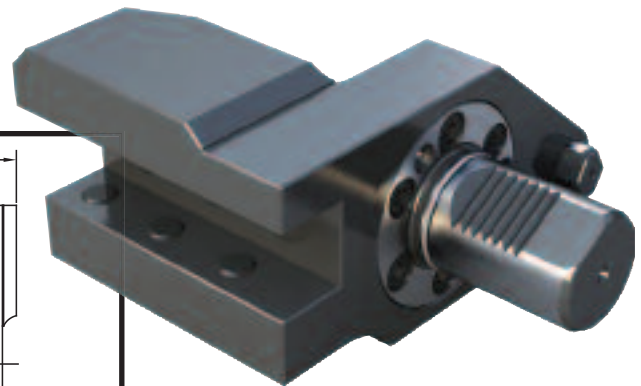

PART NUMBER	D1	B1	B2	B3	B4	L1	L2	H1	H2	H3
SQT32.1020	40	15	20	38	41	100	60	68	45	65
SQT32.1525	40	15	25	42	50	120	60	70	53	79

MAZAK





# Mazak SQT Style Double Turning Toolholder

Dual 3/4" or 1" OD Toolholder  
Form SQT-D1

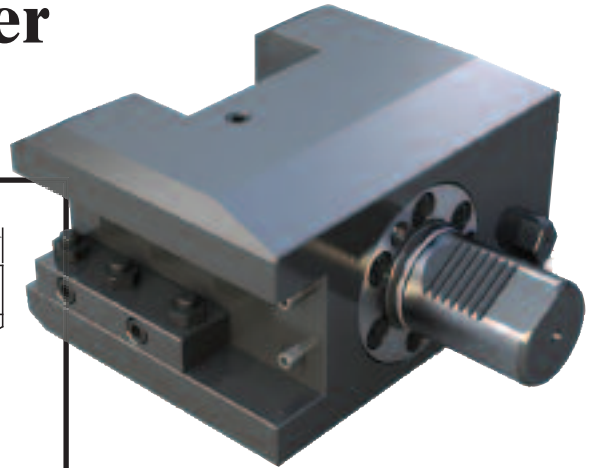
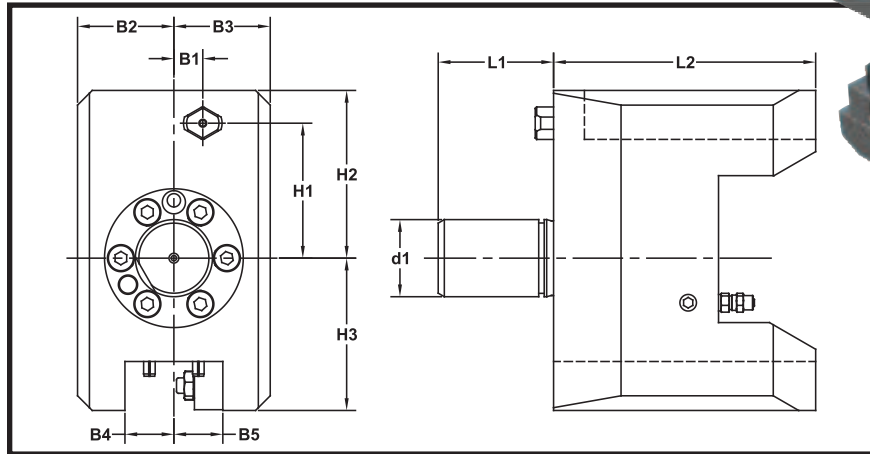

PART NUMBER	D1	B2	B3	B4	B5	L1	L2	H1	H2	H3
SQT41.1020	40	45	45	20	20	60	103	68	85	65
SQT41.1525	40	50	50	25	25	60	136	70	87	79

# Mazak SQT Style Cut-off Holder

Single Cut-off Blade  
Turning Toolholder

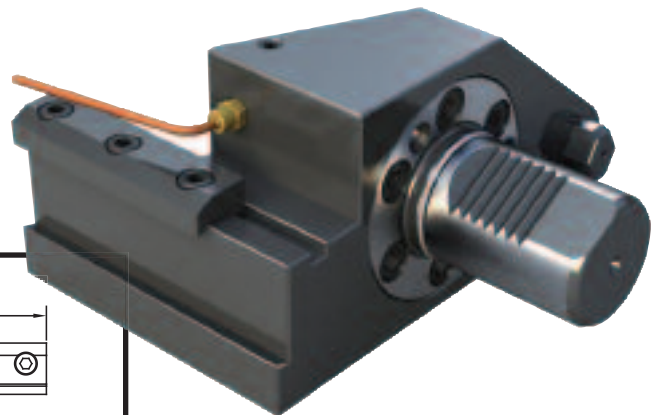
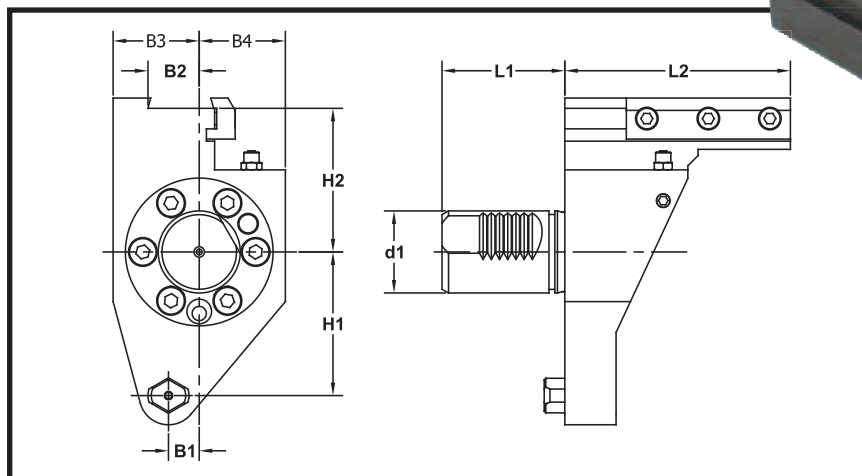

PART NUMBER	D1	B1	B2	B3	B4	L1	L2	H1	H2
SQT45.1020	40	15	21	38	38	60	92	68	62
SQT45.1525	40	15	25	42	42	60	110	70	75

MAZAK





# Mazak SQT Style Facing Holder

Form SQT-B1

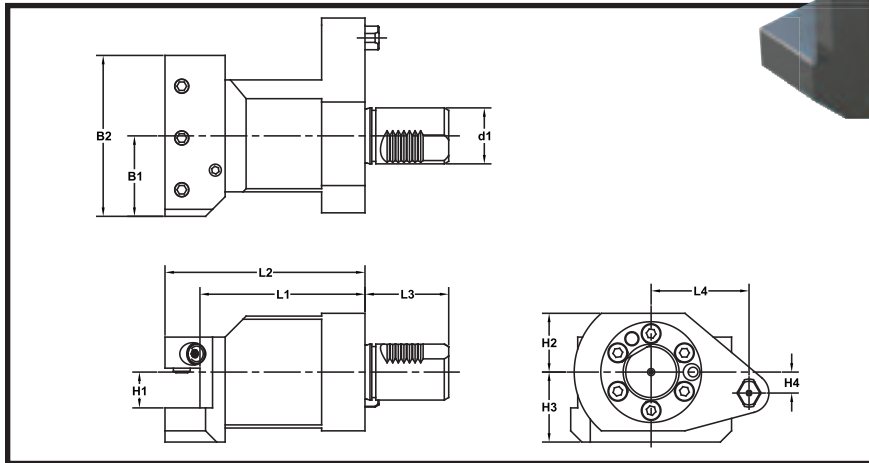
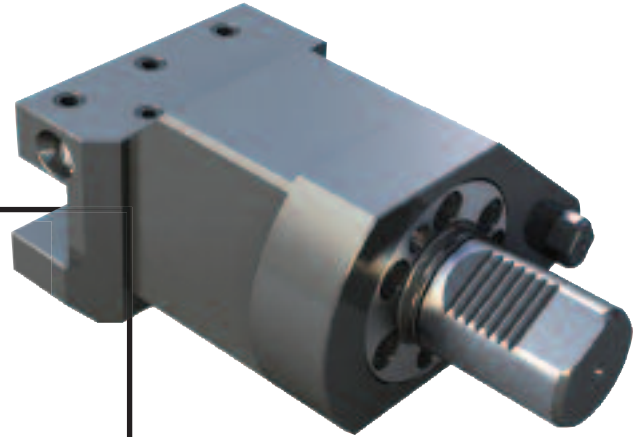

PART NUMBER	D1	B1	B2	L1	L2	L3	L4	H1	H2	H3
SQT21.1020	40	55	110	90	110	60	68	20	38	41
SQT21.1525	40	57.5	115	118	143	80	70	250	42	50

# Mazak SQT Style Single Boring Bar Holder

Peripheral Mounted ID Holder Form SQT-E1

Internal Coolant; Offset

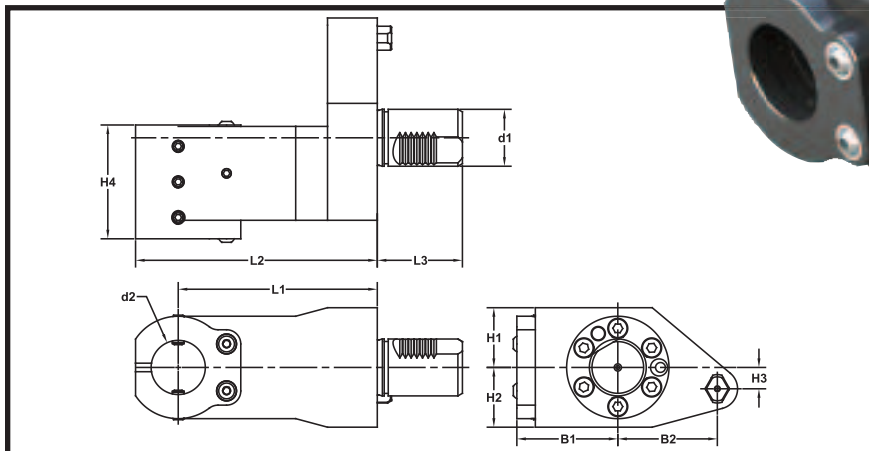
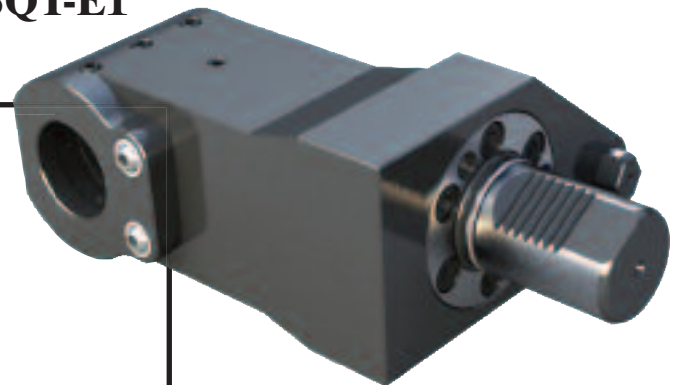

PART NUMBER	D1	D2	B1	B2	L1	L2	L3	H1	H2	H4
SQT51.1020	40	3/4	56	68	110	137	60	38	38	55
SQT51.1525	40	1	71	70	140	170	60	42	42	80

MAZAK





# Mazak SQT Style Double Boring Bar Holder

Dual 3/4" or 1" ID Holder

Form SQT-I1

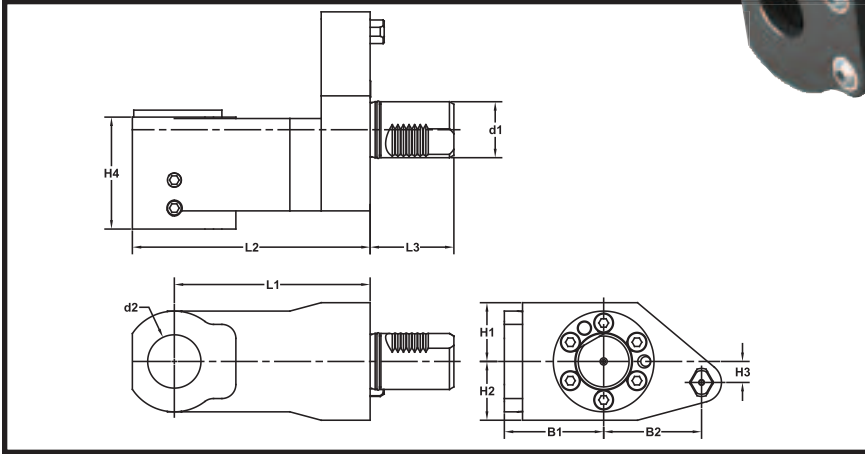
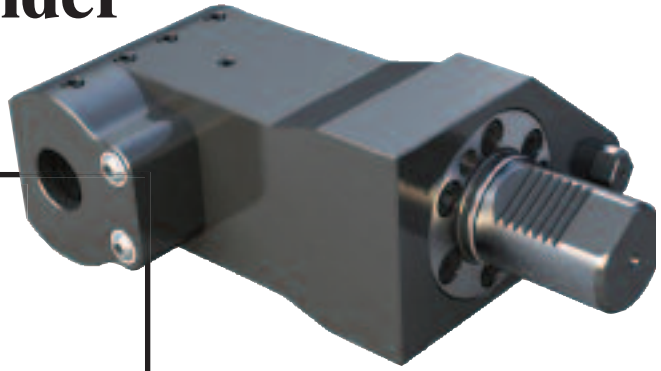

PART NUMBER	D1	D2	B1	B2	L1	L2	L3	H1	H2	H4
SQT91.1020	40	20	60	68	110	137	60	38	38	70
SQT91.1525	40	25	85	70	140	165	60	42	42	100

# Mazak SQT Style U-Drill Holder

Form SQT-E3

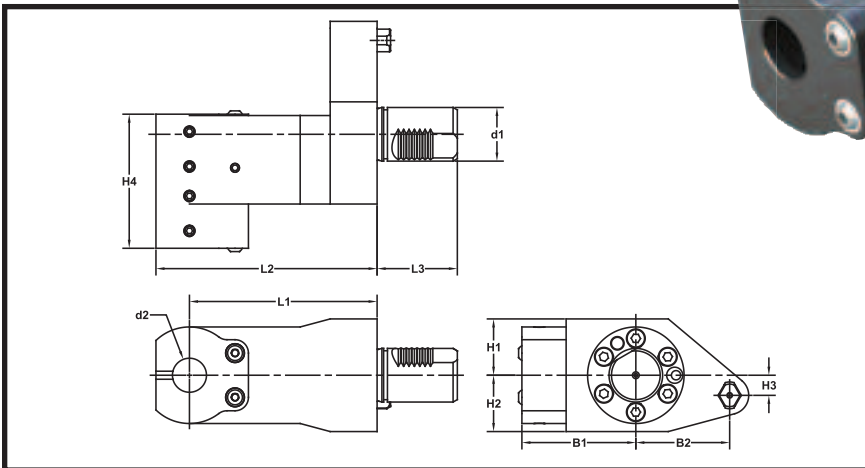

PART NUMBER	D1	D2	B1	B2	L1	L2	L3	H1	H2	H4
SQT53.1020	40	32	50	68	110	137	60	38	38	65
SQT53.1525	40	40	71	70	140	170	60	42	42	80

MAZAK

