

FAHRION®
PRÄZISION
And all runs smoothly.

ph HORN ph
Excellence in Technology



Wedge Collet CENTRO|P.WD
Innovative pull-out protection

FAHRION CENTRO|P.WD

An innovation for a more secure process



The danger of a micro creep is evident during roughing with high material removal rates or during cutting of difficult to machine materials, for example in the aircraft or in the mold making industry. High axial forces are resulting in a pull-out of the tool. Modern milling technologies as trochoidal milling necessitate either special cutting edge geometries or high clamping torques of the tool holder.

If these requirements are not fulfilled, the cutting parameters needs to be lowered or the work-piece has to be re-worked or completely produced again.

The newly developed wedge collet CENTRO|P.WD offers a 100% pull-out security and consequently the required process stability for demanding machining operations.

In connection with the Precision Collet Chuck CENTRO|P, an excellent concentricity of 6 μm within the system (at 3 x D) is reached at the same time as a high damping.

FAHRION CENTRO|P.WD wedge collet proves its positive effects by a fascinating straight, uncomplicated and easy-to-use technology.

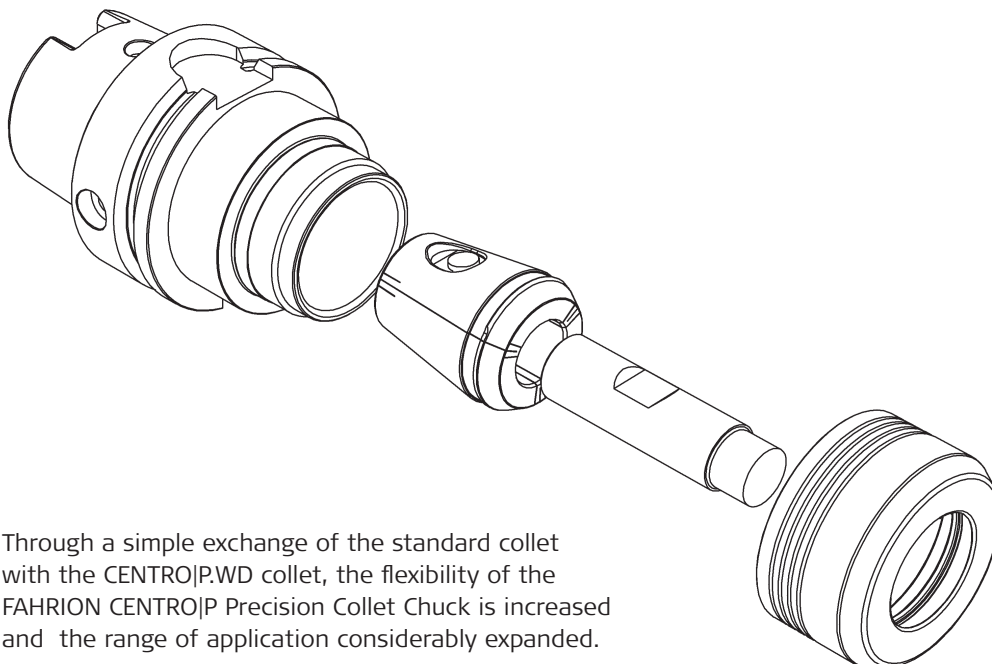

Through a simple exchange of the standard collet with the CENTRO|P.WD collet, the flexibility of the FAHRION CENTRO|P Precision Collet Chuck is increased and the range of application considerably expanded.

FAHRION CENTRO|P.WD

Easiest handling and maximum benefit

In combination with the Precision Collet Chuck CENTRO|P, the innovative wedge collet CENTRO|P.WD offers highest process security at minimal complexity.



The new wedge collet CENTRO|P.WD is an ER-collet based on DIN ISO 15488-B. This unique collet is designed for the use of standard cutting tools with Weldon shaft.

The functioning principle is easy to understand and the operator does not need specialized training. Additional investments in special devices, new chucks or special cutting tools are not needed.

The wedge collet FAHRION CENTRO|P.WD is compatible and can be used with all CENTRO|P Precision Collet Chucks.

FAHRION CENTRO|P.WD optimizes your work in multiple ways and offers:

- Highest process safety and prevention of defective parts
- Low investment costs with utilization of standard chucks
- Reduced tooling costs due to longer life-time of the tools
- Use of standard tools with Weldon shaft

The FAHRION Quality Guarantee

Pull-out protection with positive fit

- + High **stiffness**
- + Highest **concentricity**
- + Maximum **damping**
- + High **clamping torque**
- + High **balancing quality**

= FAHRION CENTRO|P Precision Collet Chuck with CENTRO|P.WD Collet

Product Range



Precision Collets GER-WD 5 µm

| Description | Part Number |  | D | L | Profile | Standard bore |
|------------------|-------------|---|----|----|---------|-----------------------|
| ® 4546E GER32-WD | 1391601 | 5 µm | 33 | 40 | ● | 12·14·16·18·1/2"·5/8" |
| ® 4726E GER40-WD | 1391701 | 5 µm | 41 | 46 | ● | 16·18·20·5/8"·3/4" |

FAHRION offers a wide selection of precision collets, precision collet chucks as well as precision products for workpiece clamping which fulfill maximum requirements in terms of concentricity, service life and manufacturing quality. In doing so, FAHRION pays particular attention to user-friendly technology oriented towards the practical requirements of the users, which is constantly advanced.

The latest catalog information is available
at any times at www.fahrion.de

FAHRION Vertriebs-GmbH
Forststraße 54
73667 Kaisersbach
Germany
Phone +49 7184 9282-0
Fax +49 7184 9282-92
info@fahrion.de
www.fahrion.de
www.shop.fahrion.de

Horn USA, Inc.
320 Premier Court, Suite 205
Franklin, TN 37067
Phone (888) 818-4676
Fax (615) 771-4101
sales@hornusa.com
www.hornusa.com