



Entwicklung
Development

Mitarbeiter
People

Kompetenz
Competence

Qualitätssicherung
Quality

Schulung
Training

Service
Service

TECHNOLOGIEVORSPRUNG IST HORN HORN - LEADERS IN GROOVING TECHNOLOGY



Modulares Werkzeugsystem HSK-T 63

zum Einsatz auf
Multi-Tasking Maschinen

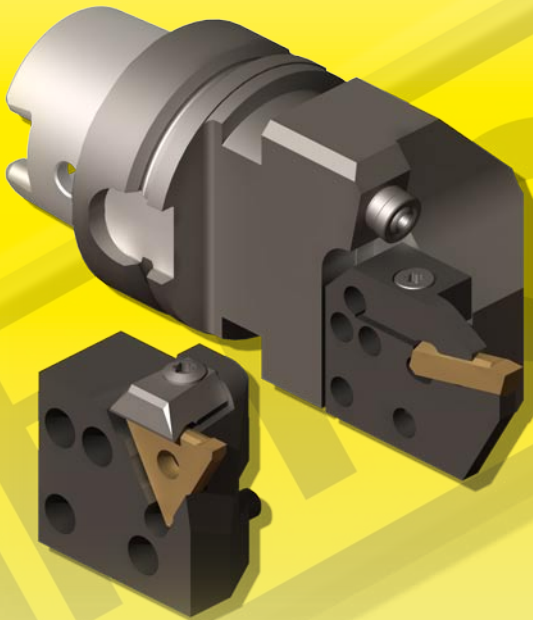

Modular Tooling System HSK-T 63

for using on multi-tasking machines



EINSTECHEN
GROOVING
ABSTECHEN
PARTING OFF
NUTFRÄSEN
GROOVE MILLING
NUTSTOSSEN
BROACHING
KOPIERFRÄSEN
PROFILE MILLING



Hartmetall-Werkzeugfabrik
Paul Horn GmbH
Unter dem Holz 33-35
72072 Tübingen
Tel.: +49 (0)7071 / 7004-0
Fax: +49 (0)7071 / 7 28 93
info@phorn.de
www.phorn.de

Kassettsitz 220 für Außenbearbeitung

Pocket seat 220 for external machining

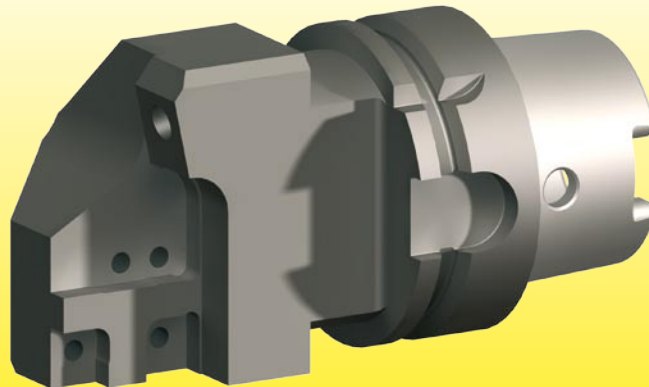

RNK360...



RNK356...



RAK224...



RAK220...



RNK100...

**Kassettsitz für Bohrstan-
gen ...B224... und ...B229...**

Pocket seat for boring bars
...B224... and ...B229...

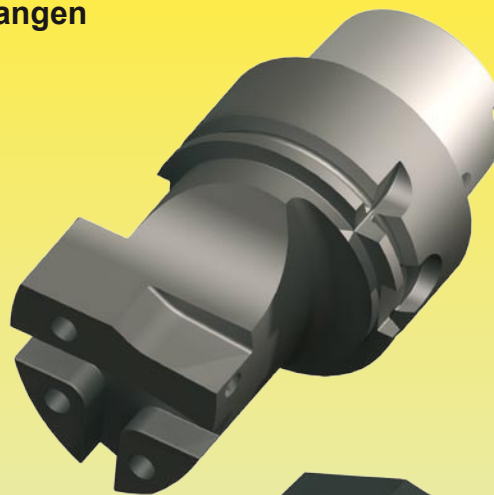

RBK229...

Details Kassetten siehe Katalog "Hartmetall-Einsteckwerkzeuge"
For details of the cassettes please see catalogue "Carbide Grooving Tools"

GRUNDHALTER Typ

BASIC TOOLHOLDER Type

HSK-T

mit innerer Kühlmittelzufuhr
with through coolant

zum Einsatz auf Multi-Tasking Maschinen
for using on multi-tasking machines



Abbildung = rechtsschneidend
Picture = right hand cutting version shown

Kassettsitz
System 220
Pocket seat system 220

Bestellnummer Part number	*	...NK224...			...NK220...			...NK356...			...NK360...		
		L	D	f	L	D	f	L	D	f	L	D	f
HSKT63.R220.110.K1	R	110	71,2	17	117	71,2	17	110	71,5	16,9	100	74,7	19,8
HSKT63.R220.120.K1	R	120			127			120			110		
HSKT63.R220.130.K1	R	130			137			130			120		
HSKT63.R220.150.K1	R	150			157			150			140		
HSKT63.R220.175.K1	R	175			182			175			165		
HSKT63.L220.110.K1	L	110			117			110			100		
HSKT63.L220.120.K1	L	120			127			120			110		
HSKT63.L220.130.K1	L	130			137			130			120		
HSKT63.L220.150.K1	L	150			157			150			140		
HSKT63.L220.175.K1	L	175			182			175			165		
WSP / Indexable Insert		S224			S229			315			312		

* Ausführung Kassetten
* Execution of cassettes

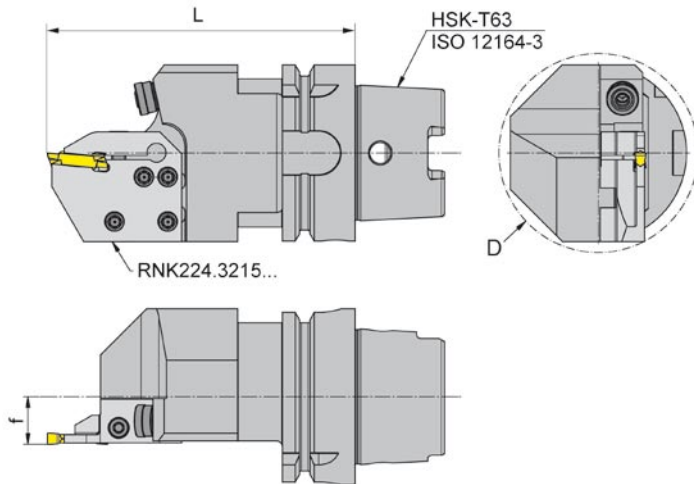
Details Kassetten siehe Katalog "Hartmetall-Einsteckwerkzeuge"
For details of the cassettes please see catalogue "Carbide Grooving Tools"

Abmessungen in mm
Dimensions in mm

Ersatzteile

Spare parts

Grundhalter Basic toolholder	Befest.schraube Screw	TORX PLUS®-Schlüssel TORX PLUS® Wrench	Kugelspritzdüse Coolant spray nozzle	Kühlmittelübergabesatz Coolant tube
HSKT63.R/L220...K1	5.12T20P	T20PQ	020.1008.2977	HSK63KMZ

GRUNDHALTER Typ

BASIC TOOLHOLDER Type

HSK-T

mit innerer Kühlmittelzufuhr
with through coolant

zum Einsatz auf Multi-Tasking Maschinen
for using on multi-tasking machines

für Axialbearbeitung
for face grooving

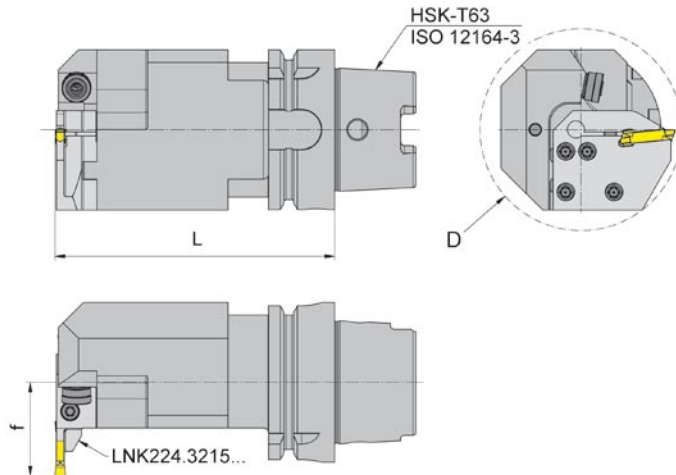

Kassettsensitz
System 220
Pocket seat system 220

Abbildung = rechtsschneidend
Picture = right hand cutting version shown

Bestellnummer Part number	*	...AK224...			...AK220...			...NK356...			...NK360...		
		L	D	f	L	D	f	L	D	f _{max}	L	D	f
HSKT63.R220.110.K2	L	110	79,5	37	110	88,1	44	109,9	74	37	112,8	79,2	27
HSKT63.R220.130.K2	L	130			130			129,9			132,8		
HSKT63.R220.150.K2	L	150			150			149,9			152,8		
HSKT63.R220.175.K2	L	175			175			174,9			177,8		
HSKT63.L220.110.K2	R	110			110			109,9			112,8		
HSKT63.L220.130.K2	R	130			130			129,9			132,8		
HSKT63.L220.150.K2	R	150			150			149,9			152,8		
HSKT63.L220.175.K2	R	175			175			174,9			177,8		
WSP / Indexable Insert		S224			S229			315			312		

* Ausführung Kassetten
* Execution of cassettes

Abmessungen in mm
Dimensions in mm

Details Kassetten siehe Katalog "Hartmetall-Einstechwerkzeuge"
For details of the cassettes please see catalogue "Carbide Grooving Tools"

Ersatzteile

Spare parts

Grundhalter Basic toolholder	Befest.schraube Screw	TORX PLUS®-Schlüssel TORX PLUS® Wrench	Kugelspritzdüse Coolant spray nozzle	Kühlmittelübergabesatz Coolant tube
HSKT63.R/L220...K2	5.12T20P	T20PQ	020.1008.2977	HSK63KMZ

GRUNDHALTER Typ

BASIC TOOLHOLDER Type

HSK-T

mit innerer Kühlmittelzufuhr
with through coolant

Kombihalter mit 10° Spindelstellung an Multi-Tasking Maschinen
Combined Toolholder with 10° orientation to spindle in multi-tasking machines



Abbildung = rechtsschneidend
Picture = right hand cutting version shown

Kassettsitz
System 220
Pocket seat system 220

Bestellnummer Part number	*	...NK224...			...NK220...			...NK365...			...NK360...		
		L	D	f	L	D	f	L	D	f	L	D	f
HSKT63.R220.110.K3	R	110	83,8	39,7	117	84,1	33,7	110	84,4	39,6	100	88,7	42,5
HSKT63.R220.120.K3	R	120			127			120			110		
HSKT63.R220.130.K3	R	130			137			130			120		
HSKT63.R220.150.K3	R	150			157			150			140		
HSKT63.R220.175.K3	R	175			182			175			165		
HSKT63.L220.110.K3	L	110			117			110			100		
HSKT63.L220.120.K3	L	120			127			120			110		
HSKT63.L220.130.K3	L	130			137			130			120		
HSKT63.L220.150.K3	L	150			157			150			140		
HSKT63.L220.175.K3	L	175			182			175			165		
WSP / Indexable Insert		S224			S229			315			312		

* Ausführung Kassetten
* Execution of cassettes

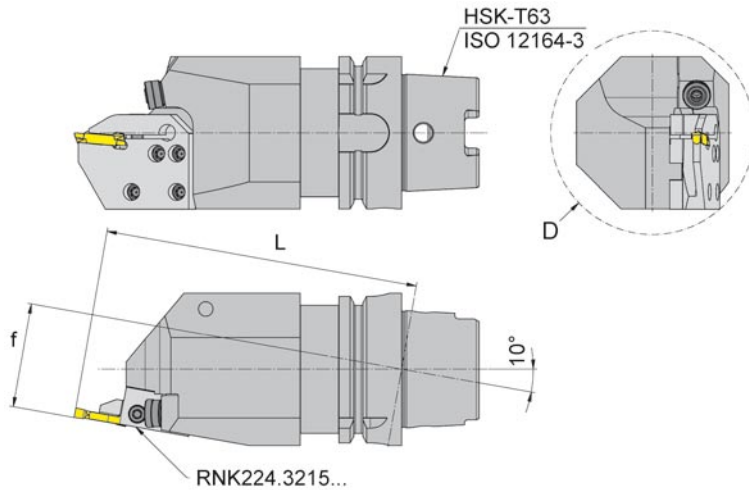
Details Kassetten siehe Katalog "Hartmetall-Einsteckwerkzeuge"
For details of the cassettes please see catalogue "Carbide Grooving Tools"

Abmessungen in mm
Dimensions in mm

Ersatzteile

Spare parts

Grundhalter Basic toolholder	Befest.schraube Screw	TORX PLUS®-Schlüssel TORX PLUS® Wrench	Kugelspritzdüse Coolant spray nozzle	Kühlmittelübergabesatz Coolant tube
HSKT63.R/L220...K3	5.12T20P	T20PQ	020.1008.2977	HSK63KMZ

GRUNDHALTER Typ

BASIC TOOLHOLDER Type

HSK-T

mit innerer Kühlmittelzufuhr
with through coolant

Kombihalter mit 10° Spindelstellung an Multi-Tasking Maschinen
Combined Toolholder with 10° orientation to spindle in multi-tasking machines

für Axialbearbeitung
for face grooving



Abbildung = rechtsschneidend
Picture = right hand cutting version shown

Kassettsenz
System 220
Pocket seat system 220

Bestellnummer Part number	*	...AK224...			...AK220...			...NK356...			...NK360...		
		L	D	f	L	D	f	L	D	f	L	D	f
HSKT63.R220.110.K4	L	110			110			109,9			112,8		
HSKT63.R220.130.K4	L	130			130			129,9			132,8		
HSKT63.R220.150.K4	L	150			150			149,9			152,8		
HSKT63.R220.175.K4	L	175			175			174,9			177,8		
HSKT63.L220.110.K4	R	110	75,8	53,2	110	83,7	60,2	109,9	72	33,2	112,8	76,5	43,2
HSKT63.L220.130.K4	R	130			130			129,9			132,8		
HSKT63.L220.150.K4	R	150			150			149,9			152,8		
HSKT63.L220.175.K4	R	175			175			174,9			177,8		
WSP / Indexable Insert			S224		S229			315			312		

* Ausführung Kassetten
* Execution of cassettes

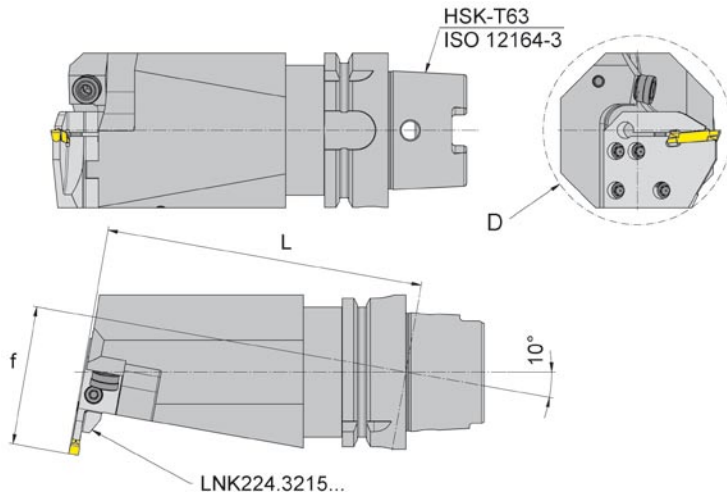
Abmessungen in mm
Dimensions in mm

Details Kassetten siehe Katalog "Hartmetall-Einsteckwerkzeuge"
For details of the cassettes please see catalogue "Carbide Grooving Tools"

Ersatzteile

Spare parts

Grundhalter Basic toolholder	Befest.schraube Screw	TORX PLUS®-Schlüssel TORX PLUS® Wrench	Kugelspritzdüse Coolant spray nozzle	Kühlmittelübergabesatz Coolant tube
HSKT63.R/L220...K4	5.12T20P	T20PQ	020.1008.2977	HSK63KMZ

GRUNDHALTER Typ

BASIC TOOLHOLDER Type

HSK-T

mit innerer Kühlmittelzufuhr
with through coolant

zum Einsatz auf Multi-Tasking Maschinen
for using on multi-tasking machines

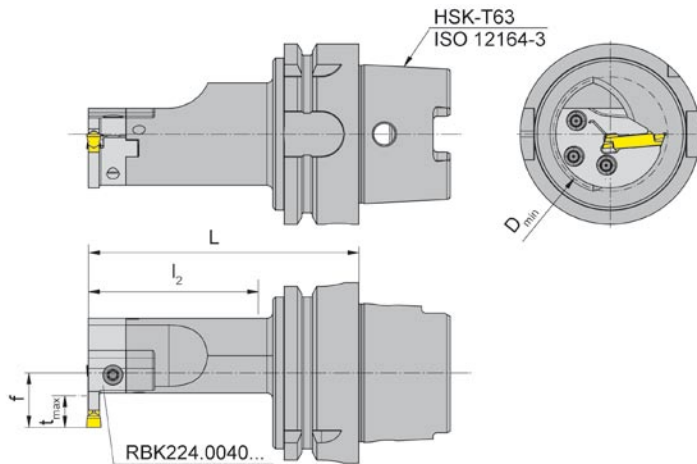

für Innenbearbeitung
for internal machining

Bestellnummer Part number	*	...BK224...					...BK229...								
		L	l ₂	f	D _{min1}	t _{max1}	L	l ₂	f	D _{min1}	t _{max1}	D _{min2}	t _{max2}		
HSKT63.RB224.095.K2	R	95	60	19	39	11									
HSKT63.RB224.115.K2	R	115	80												
HSKT63.LB224.095.K2	L	95	60												
HSKT63.LB224.115.K2	L	115	80												
HSKT63.RB229.095.K2	R						95	60	24,2	50	12	60	15		
HSKT63.RB229.115.K2	R						115	80							
HSKT63.LB229.095.K2	L						95	60							
HSKT63.LB229.115.K2	L						115	80							
WSP / Indexable Insert		S224					S229								

* Ausführung Kassetten
* Execution of cassettes

Abmessungen in mm
Dimensions in mm

Details Kassetten siehe Katalog "Hartmetall-Einstechwerkzeuge"
For details of the cassettes please see catalogue "Carbide Grooving Tools"

Ersatzteile

Spare parts

Grundhalter Basic toolholder	Spannschraube Screw	TORX PLUS®-Schlüssel TORX PLUS® Wrench	Kühlmittelübergabesatz Coolant tube
HSKT63.R/LB...K2	030.0518T20P	T20P	HSK63KMZ

- **EINSTECHDREHEN**
- **FORM-EINSTECHDREHEN**
- **GEWINDEDREHEN**
- **AXIAL-EINSTECHDREHEN**
- **ABSTECHE**
- **NUT-ZIRKULARFRÄSEN**
- **BOHR-ZIRKULARFRÄSEN**
- **GEWINDEFÄSEN**
- **T-NUTENFRÄSEN**
- **KOPIERFRÄSEN**
- **NUTSTOSSEN**
- **AUSSPINDELN**
- **GROOVING**
- **PROFILING**
- **THREADING**
- **FACE GROOVING**
- **PARTING OFF**
- **GROOVE MILLING BY CIRCULAR INTERPOLATION**
- **BORE MILLING BY CIRCULAR INTERPOLATION**
- **THREAD MILLING**
- **T-SLOT-MILLING**
- **PROFILE MILLING**
- **BROACHING**
- **BORING**



ISO 9001
ISO 14001

HARTMETALL WERKZEUGFABRIK

PAUL HORN GmbH

Unter dem Holz 33-35 Tel.: +49 (0)7071-7004 0
D-72072 Tübingen Fax: +49 (0)7071-7 28 93

E-mail: info@phorn.de
www.phorn.de

HORN CUTTING TOOLS Ltd.

32 New Street Tel.: +44 (0)1 425 481 800
Ringwood Fax: +44 (0)1 425 481 888
Hampshire
BH24 3AD

E-mail: info@phorn.co.uk
www.phorn.co.uk

HORN S.A.S.

665, av. Blaise Pascal Tel.: +33 (0)1 64 88 5958
Zone Industrielle Fax: +33 (0)1 64 88 6049
77127 Lieusaint

E-mail: infos@horn.fr
www.horn.fr

HORN USA, Inc.

320 Premier Court Tel.: +1 (888)818-HORN
Suite 205 Fax: +1 (615)771-4101
Franklin, TN 37067

E-mail: sales@hornusa.com
www.hornusa.com

HORN Magyarország Kft.

H-9021 Győr Tel.: +36 96 55 05 31
Szent István út 10/A Fax: +36 96 55 05 32

E-mail: technik@phorn.hu
www.phorn.hu

