





[www.ititooling.com](http://www.ititooling.com)



**ITI TOOLING COMPANY INC.** is a unique and experienced supply company, offering an extensive range of top-quality "Driven" and "Static" tool holding solutions for most CNC Lathes from around the world.

We supply the world's finest CNC Lathe Tool Holders, manufactured by companies who have been recognized as industry leaders for decades. Our clients have gained confidence in the quality and "know-how" that comes from our many years experience addressing a broad spectrum of applications in all industries. Applications that utilize not only our standard Tool Holders but also "Multi-Head" and "Multi-Spindle" Units, along with other custom designs, which have economically solved problems for today's more demanding, multi-tasking and highly competitive manufacturing environments.

We offer precision, top quality toolholders and spindle units designed as Bolt-on, VDI and other styles of mounting systems that are available and manufactured to meet the highest standards of quality using only the finest materials available.



**ITI TOOLING COMPANY INC.**

37 Orchard St., Ramsey, N.J. 07446 1-888-88-INDEX

## ITI - Turning Tool (Right Hand) - Face

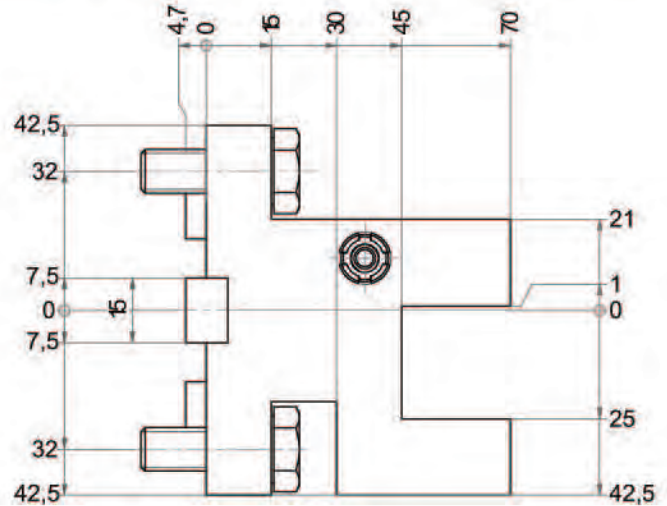
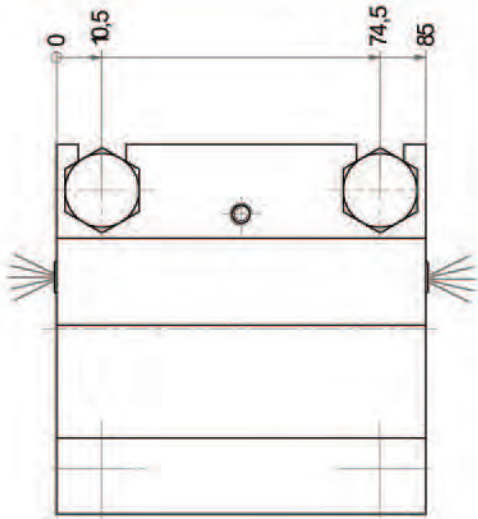

**Part No.**  
**# 5.BMT25P2000**

Subject to technical modifications

Coolant	For Square Tool	
Ext.	25mm (1.000")	X=(70mm)

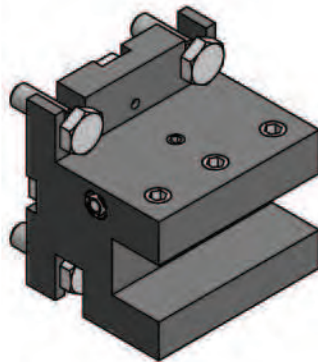

**ITI TOOLING COMPANY**

A Division of **INDEXING TECHNOLOGIES INC.**

37 Orchard Street., Ramsey, NJ. 07446 - Phone (201) 934-6333 - Fax (201) 934-6333 [www.indexingtechnologies.com](http://www.indexingtechnologies.com)  
[www.ititooling.com](http://www.ititooling.com)



ITI - Double OD Turning Tool Holder

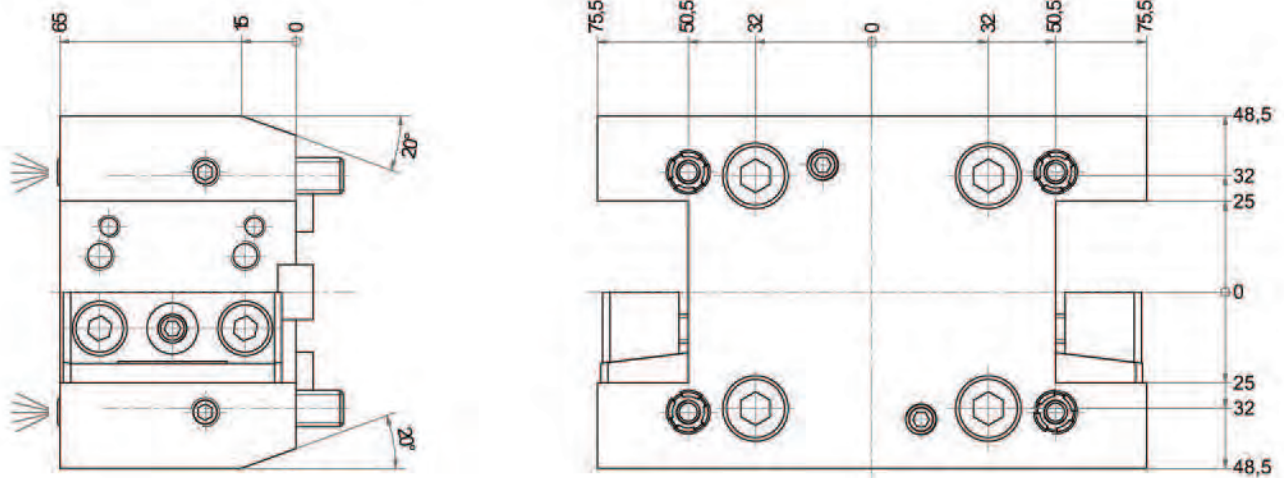

Part No.  
# 15.BMT25P2000

Subject to technical modifications

Coolant	For Square Tool	
Ext.	25mm (1.000")	X= 70mm.

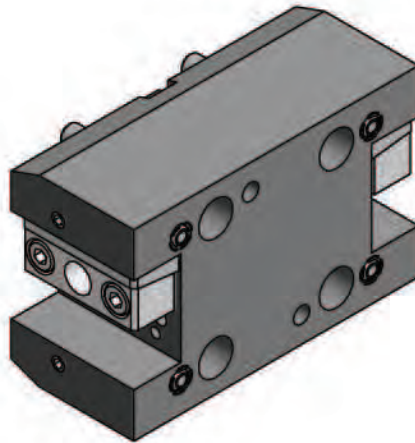

**ITI TOOLING COMPANY**

A Division of **INDEXING TECHNOLOGIES INC.**

37 Orchard Street., Ramsey, NJ. 07446 - Phone (201) 934-6333 - Fax (201) 934-6333 www.indexingtechnologies.com  
www.ititooling.com

## ITI - OD Turning Tool Holder

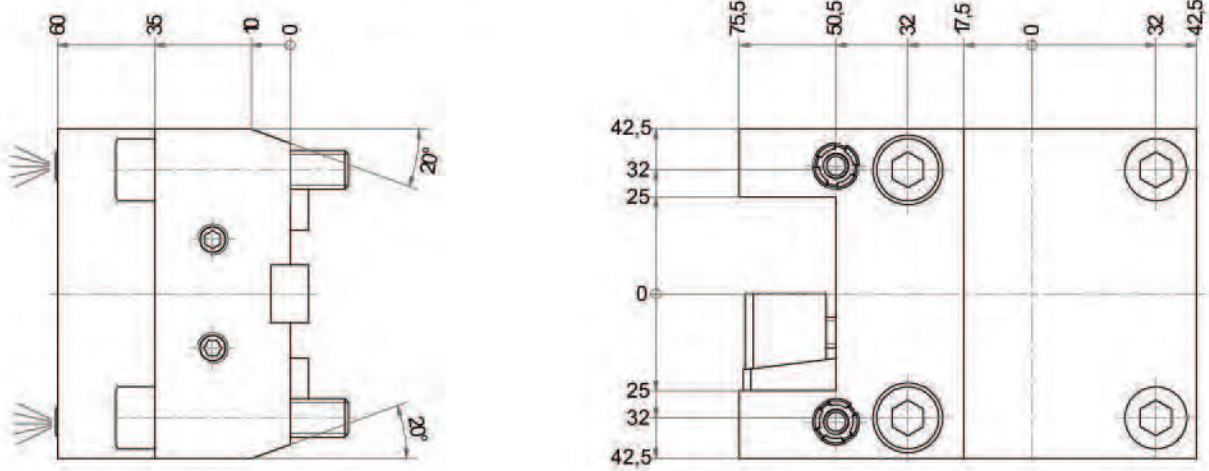

**Part No.**  
**# 4.BMT25P2000**

Subject to technical modifications

Coolant	For Square Tool	X
Ext.	25mm (1.000")	X=(75.5mm)

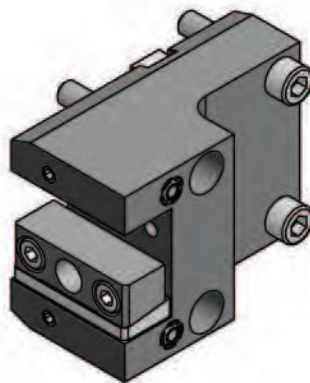

**ITI TOOLING COMPANY**

A Division of **INDEXING TECHNOLOGIES INC.**

37 Orchard Street., Ramsey, NJ. 07446 - Phone (201) 934-6333 - Fax (201) 934-6333 [www.indexingtechnologies.com](http://www.indexingtechnologies.com)  
[www.ititooling.com](http://www.ititooling.com)

## ITI - Boring Bar Holder

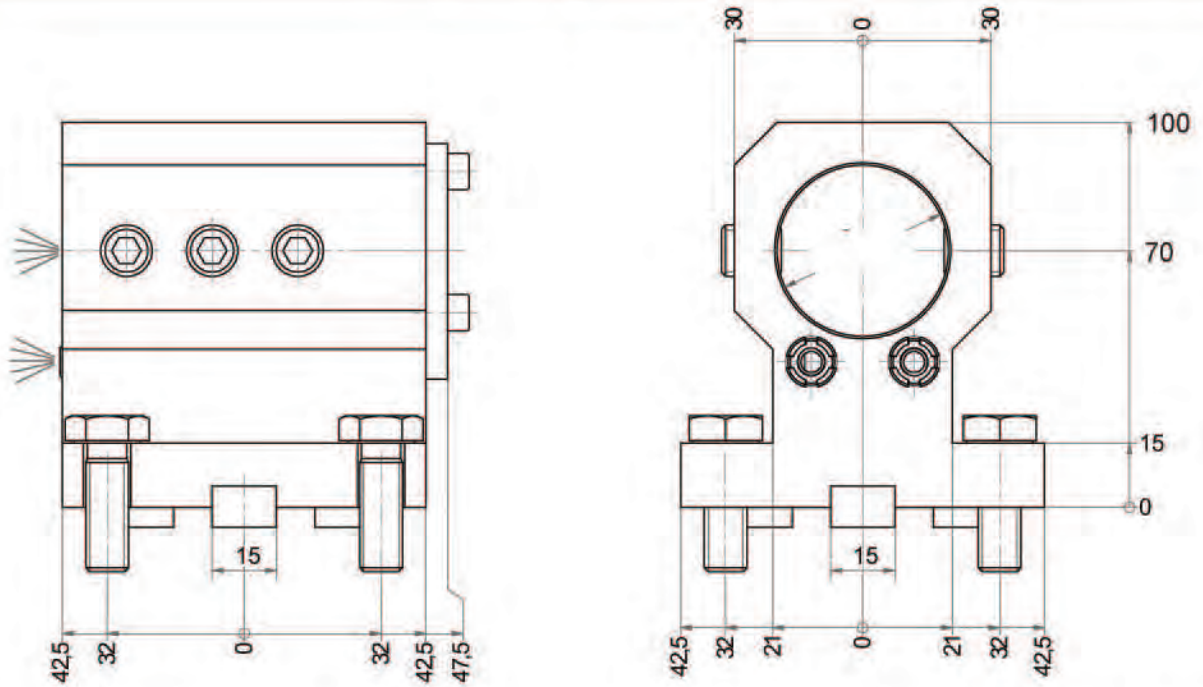

**Part No.**  
**# 19.BMT40P2000**

Subject to technical modifications

Coolant	For Round Tool	X
Ext.	40mm (Inch sizes available)	X= 70mm.

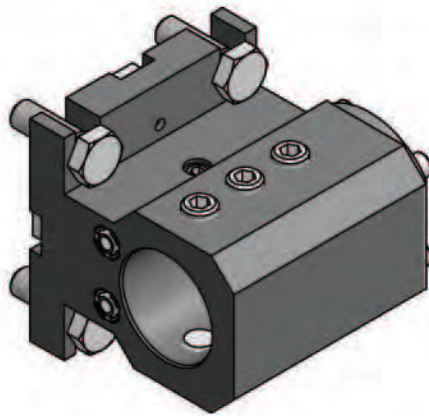

**ITI TOOLING COMPANY**

A Division of **INDEXING TECHNOLOGIES INC.**

37 Orchard Street., Ramsey, NJ. 07446 - Phone (201) 934-6333 - Fax (201) 934-6333 www.indexingtechnologies.com  
www.ititooling.com



## ITI - Axial (straight) Drilling and Milling Head

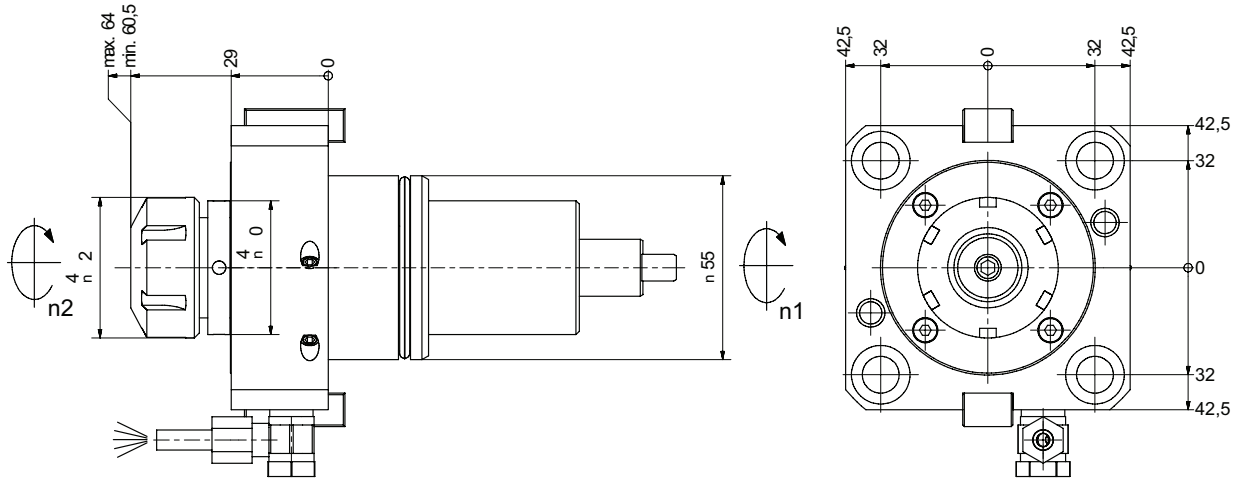

**Part No.**  
**# 40.55251809N4**

Subject to technical modifications

Coolant	i	M1	M2	n1	n2	Collet	Clamping range	Tapping Collet
Ext.	1:1	25 Nm	25 Nm	6000 1/min	6000 1/min	ER25	1.0 - 16.0	ET-1-25 M3-M10

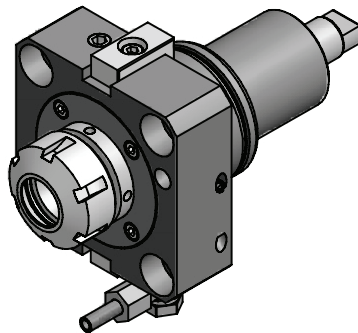

**ITI TOOLING COMPANY**

A Division of **INDEXING TECHNOLOGIES INC.**

37 Orchard Street., Ramsey, NJ. 07446 - Phone (201) 934-6333 - Fax (201) 934-6333 www.indexingtechnologies.com  
 www.ititooling.com

## ITI - Axial (straight) Drilling and Milling Head

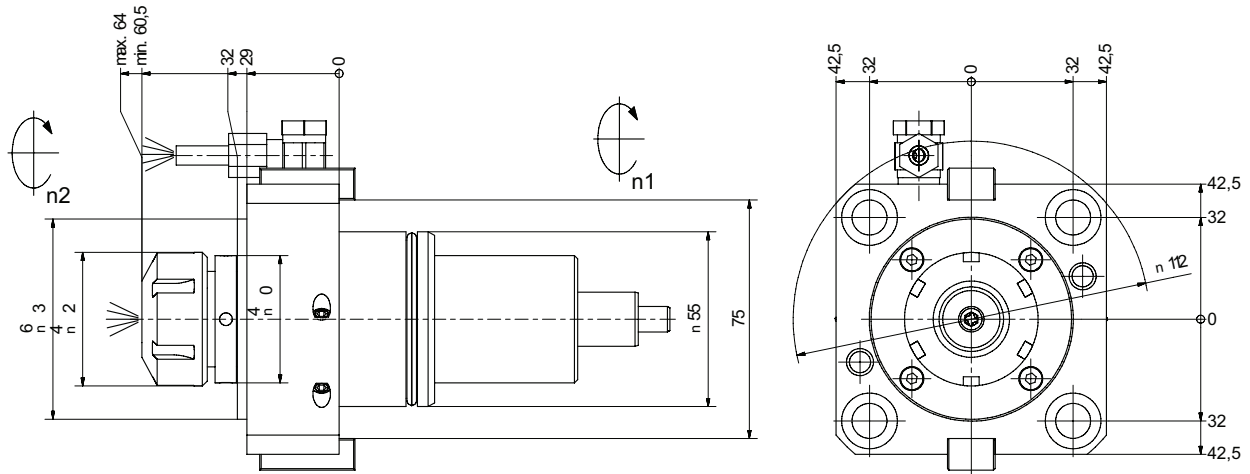

**Part No.**  
**# 40.55251809N4-IK**

Subject to technical modifications

Coolant	i	M1	M2	n1	n2	Collet	Clamping range	Tapping Collet
Int. / Ext.	1:1	25 Nm	25 Nm	6000 1/min	6000 1/min	ER25	1.0 - 16.0	ET-1-25 M3-M10

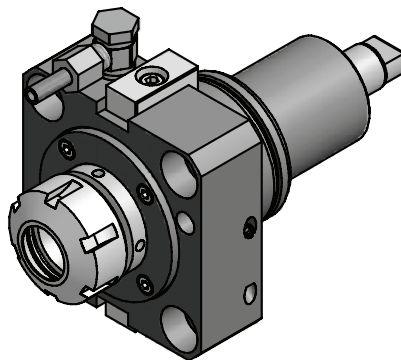

**ITI TOOLING COMPANY**

A Division of **INDEXING TECHNOLOGIES INC.**

37 Orchard Street., Ramsey, NJ. 07446 - Phone (201) 934-6333 - Fax (201) 934-6333 [www.indexingtechnologies.com](http://www.indexingtechnologies.com)  
[www.ititooling.com](http://www.ititooling.com)



## ITI - Axial (straight) Drilling and Milling Head

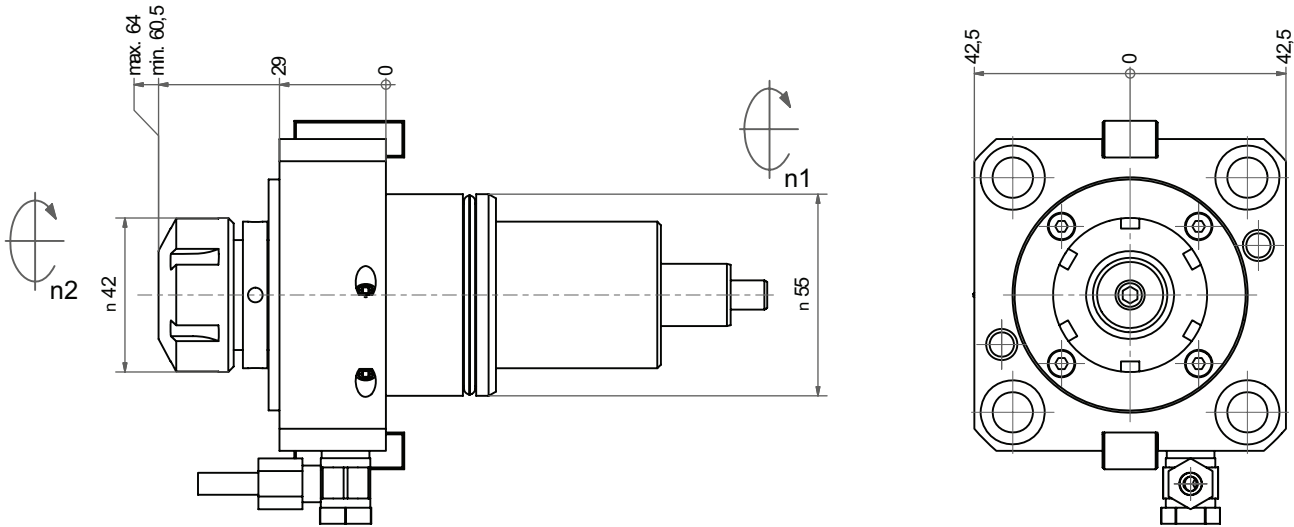

**Part No.**  
**# 40.5525KR1809N4**

Subject to technical modifications

Coolant	i	M1	M2	n1	n2	Collet	Clamping range	Tapping Collet
Ext.	1:1	25 Nm	25 Nm	5000 1/min	5000 1/min	ER25	1.0 - 16.0	ET-1-25 M3-M10

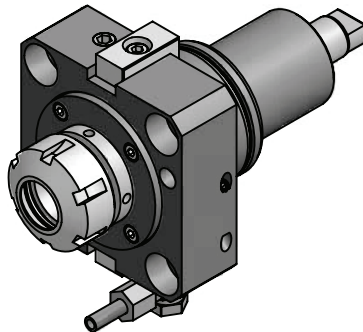

**ITI TOOLING COMPANY**

A Division of **INDEXING TECHNOLOGIES INC.**

37 Orchard Street., Ramsey, NJ. 07446 - Phone (201) 934-6333 - Fax (201) 934-6333 www.indexingtechnologies.com  
 www.ititooling.com

ITI - Swivel Head

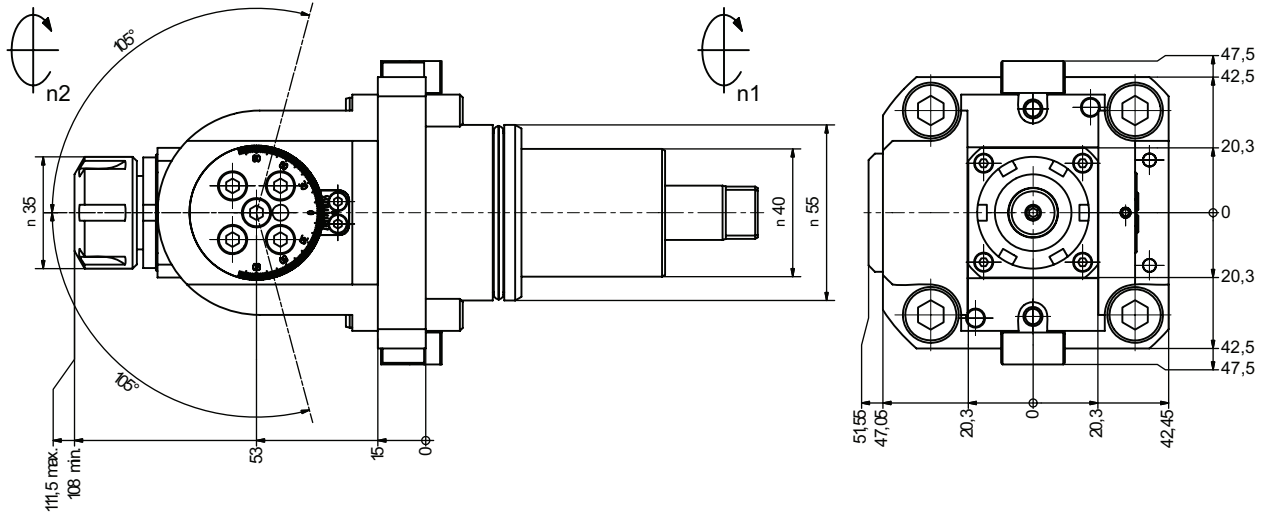

Part No.  
# 63.55201809

Subject to technical modifications

Coolant	i	M1	M2	n1	n2	Collet	Clamping range	Tapping Collet
Ext.	1:1	16 Nm	16 Nm	6000 1/min	6000 1/min	ER20	1.0 - 13.0	ET-1-20 M2-M6

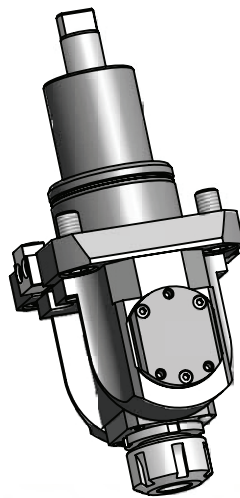

ITI TOOLING COMPANY

A Division of INDEXING TECHNOLOGIES INC.

37 Orchard Street., Ramsey, NJ. 07446 - Phone (201) 934-6333 - Fax (201) 934-6333 www.indexingtechnologies.com  
www.ititooling.com

## ITI - Radial (90°) Milling Head

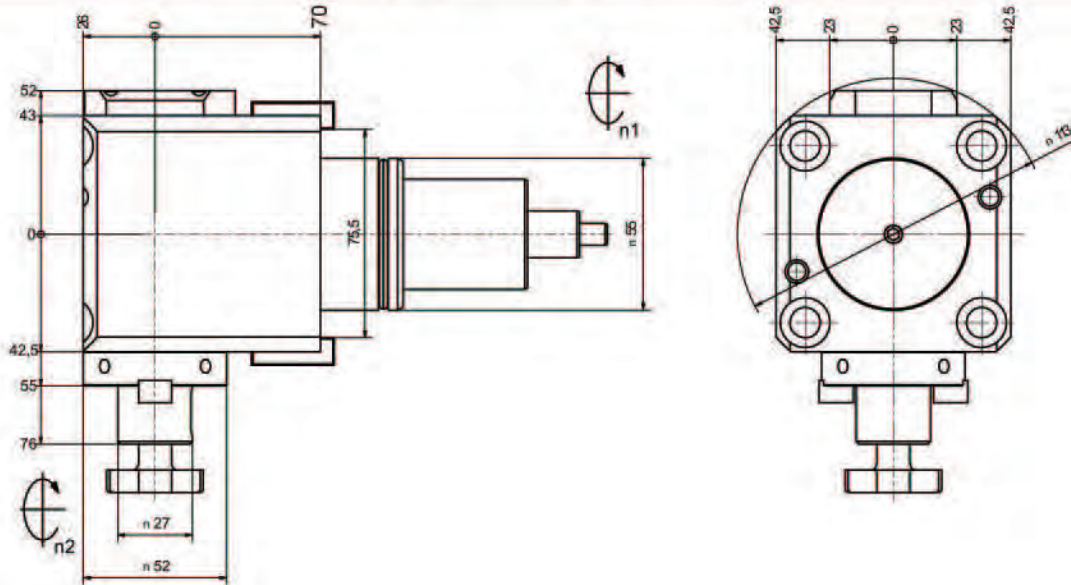

**Part No.**  
**# 62.55271809N4**

Subject to technical modifications

Coolant	i	M1	M2	n1	n2	Tooling System	X
Ext.	1:1	25 Nm	25 Nm	6000 1/min	6000 1/min	Shell Mill Holder (27mm)	X= 70mm.

Inch Size Arbors Available

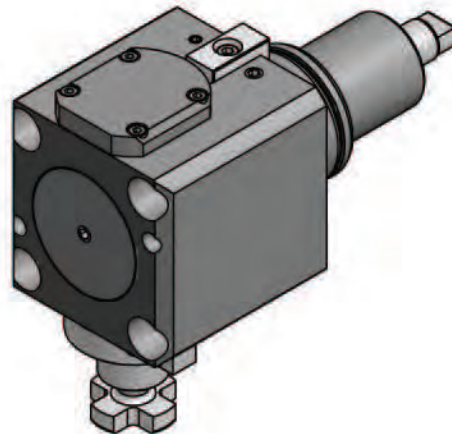

**ITI TOOLING COMPANY**

A Division of **INDEXING TECHNOLOGIES INC.**

37 Orchard Street., Ramsey, NJ. 07446 - Phone (201) 934-6333 - Fax (201) 934-6333 [www.indexingtechnologies.com](http://www.indexingtechnologies.com)  
[www.ititooling.com](http://www.ititooling.com)



## ITI - Radial (90°) Milling Head

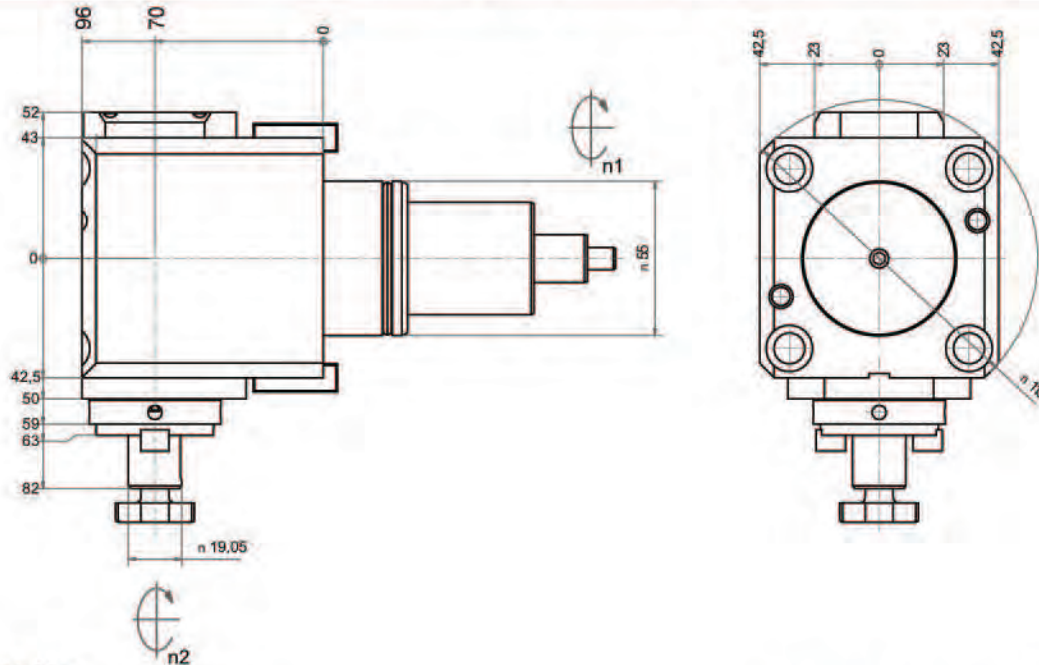

**Part No.**  
**# 62.5519.05KR1809i2N4**

Subject to technical modifications

Coolant	i	M1	M2	n1	n2	Tooling System	X
Ext.	2:1	20 Nm	40 Nm	6000 1/min	3000 1/min	Shell Mill Holder	X=70mm.

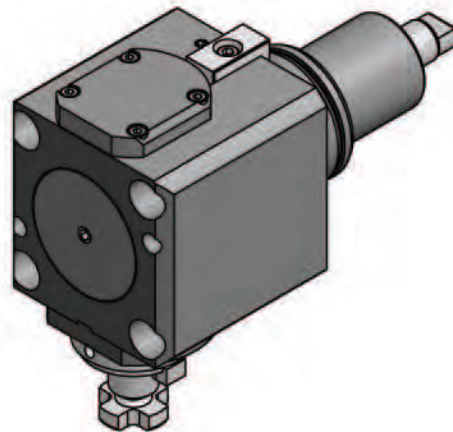

**ITI TOOLING COMPANY**

A Division of **INDEXING TECHNOLOGIES INC.**

37 Orchard Street., Ramsey, NJ. 07446 - Phone (201) 934-6333 - Fax (201) 934-6333 [www.indexingtechnologies.com](http://www.indexingtechnologies.com)  
[www.ititooling.com](http://www.ititooling.com)

## ITI - Radial (90°) Drilling and Milling Head

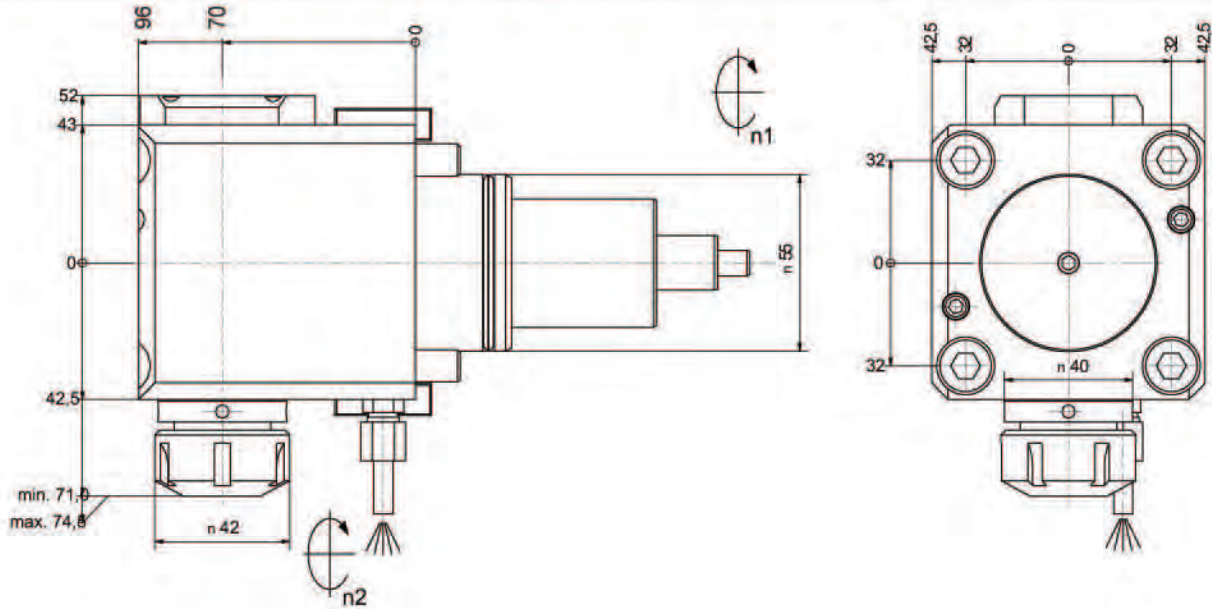

**Part No.**  
**# 60.55251809N4**

Subject to technical modifications

Coolant	i	M1	M2	n1	n2	Collet	Clamping range	Tapping Collet
Ext.	1:1	25 Nm	25 Nm	6000 1/min	6000 1/min	ER25	1.0 - 16.0	ET-1-25 M3-M10

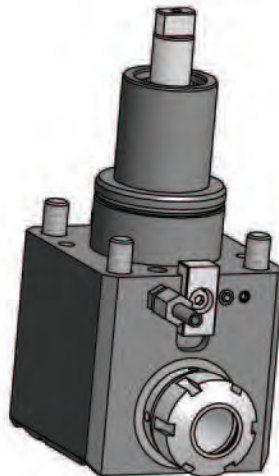

**ITI TOOLING COMPANY**

A Division of **INDEXING TECHNOLOGIES INC.**

37 Orchard Street., Ramsey, NJ. 07446 - Phone (201) 934-6333 - Fax (201) 934-6333 [www.indexingtechnologies.com](http://www.indexingtechnologies.com)  
[www.ititooling.com](http://www.ititooling.com)



## ITI - Radial (90°) Drilling and Milling Head

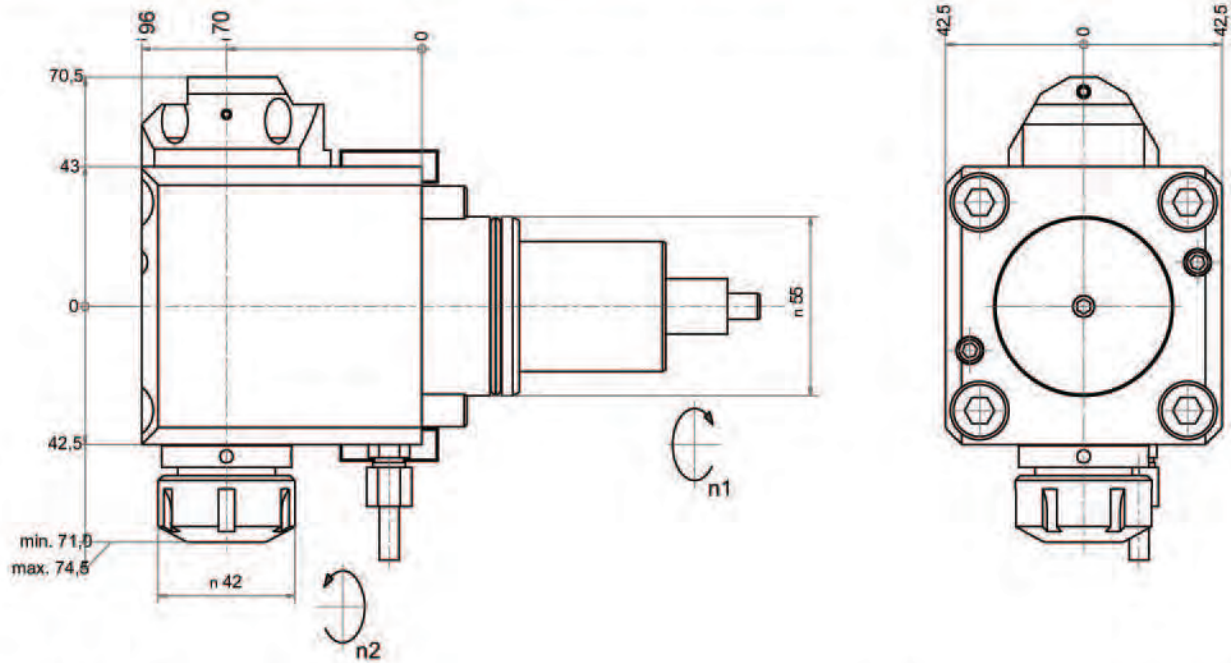

**Part No.**  
# 60.55251809-IKN4

Subject to technical modifications

Coolant	i	M1	M2	n1	n2	Collet	Clamping range	Tapping Collet
Int. / Ext.	1:1	25 Nm	25 Nm	6000 1/min	6000 1/min	ER25	1.0 - 16.0	ET-1-25 M3-M10

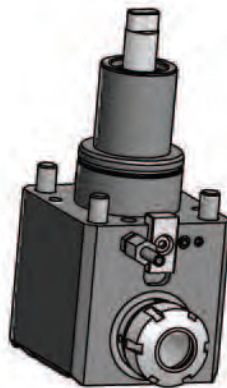

**ITI TOOLING COMPANY**

A Division of **INDEXING TECHNOLOGIES INC.**

37 Orchard Street., Ramsey, NJ. 07446 - Phone (201) 934-6333 - Fax (201) 934-6333 www.indexingtechnologies.com  
www.ititooling.com



## ITI - Radial (90°) Drilling and Milling Head

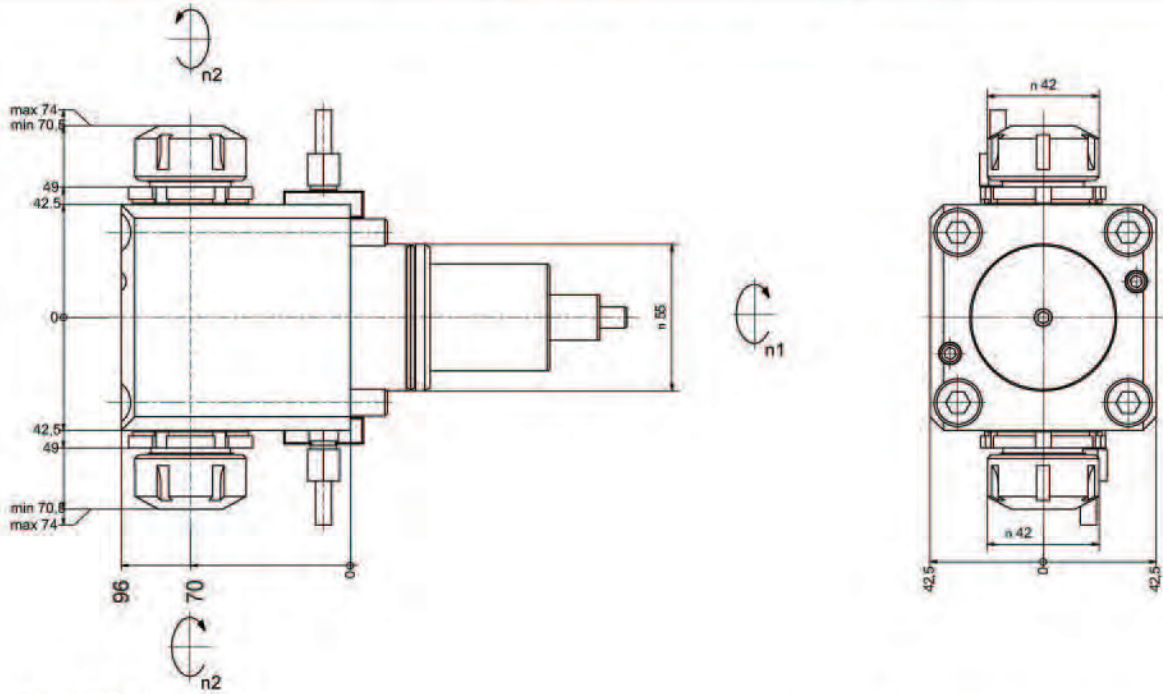

**Part No.**  
# 60.5525D1809N4

Subject to technical modifications

Coolant	i	M1	M2	n1	n2	Collet	Clamping range	Tapping Collet
Ext.	1:1	25 Nm	25 Nm	6000 1/min	6000 1/min	ER25	1.0 - 16.0	ET-1-25 M3-M10

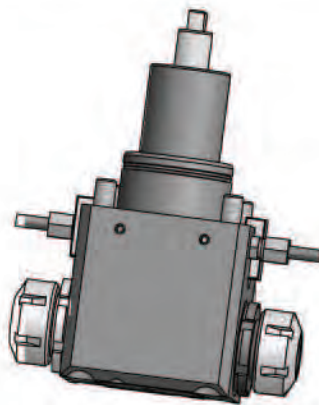

**ITI TOOLING COMPANY**

A Division of **INDEXING TECHNOLOGIES INC.**

37 Orchard Street., Ramsey, NJ. 07446 - Phone (201) 934-6333 - Fax (201) 934-6333 www.indexingtechnologies.com  
www.ititooling.com

## ITI - Radial (90°) Drilling and Milling Head

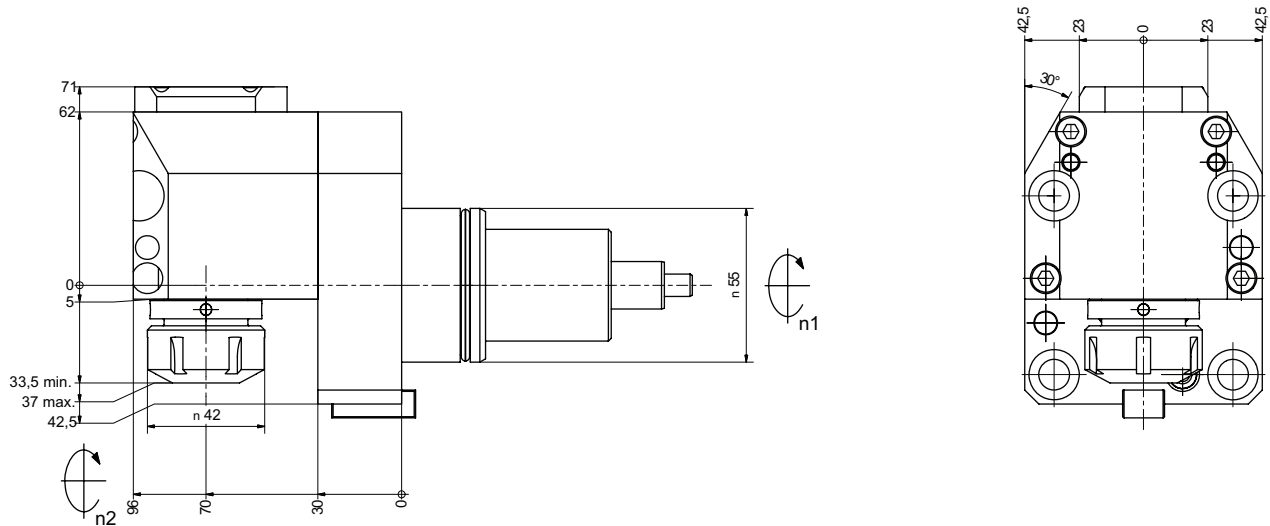

**Part No.**  
**# 80.55251809**

Subject to technical modifications

Coolant	i	M1	M2	n1	n2	Collet	Clamping range	Tapping Collet
Ext.	1:1	25 Nm	25 Nm	6000 1/min	6000 1/min	ER25	1.0 - 16.0	ET-1-25 M3-M10

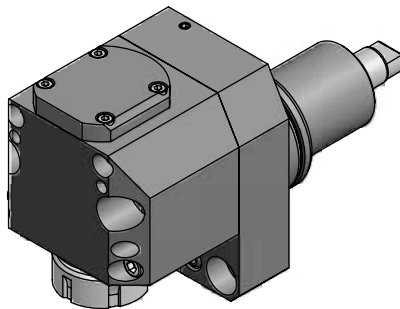

**ITI TOOLING COMPANY**

A Division of **INDEXING TECHNOLOGIES INC.**

37 Orchard Street., Ramsey, NJ. 07446 - Phone (201) 934-6333 - Fax (201) 934-6333 [www.indexingtechnologies.com](http://www.indexingtechnologies.com)  
[www.ititooling.com](http://www.ititooling.com)

## ITI - Axial (straight) Drilling and Milling Head

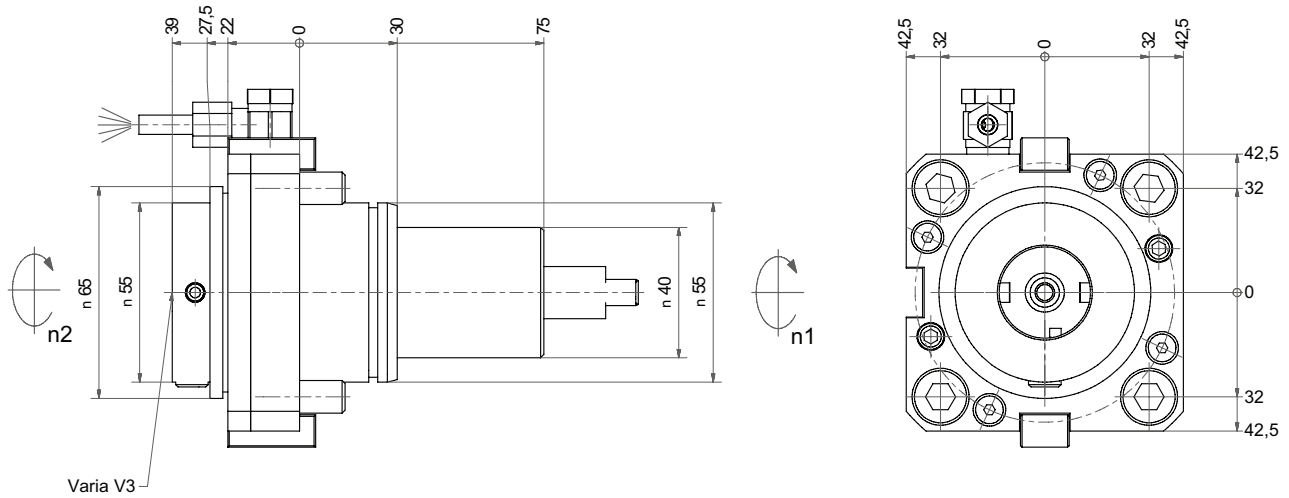

**Part No.**  
**# 80.55V31809N4**

Subject to technical modifications

Coolant	i	M1	M2	n1	n2	Tooling System	X
Ext.	1:1	25 Nm	25 Nm	6000 1/min	6000 1/min	Varia V3	X=(39mm)

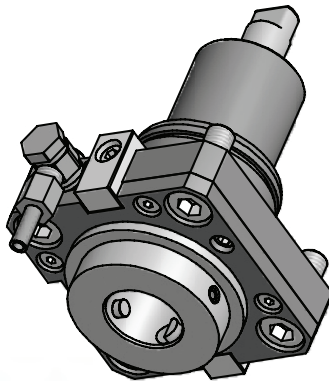

**ITI TOOLING COMPANY**

A Division of **INDEXING TECHNOLOGIES INC.**

37 Orchard Street., Ramsey, NJ. 07446 - Phone (201) 934-6333 - Fax (201) 934-6333 [www.indexingtechnologies.com](http://www.indexingtechnologies.com)  
[www.ititooling.com](http://www.ititooling.com)



## ITI - Axial (straight) Drilling and Milling Head

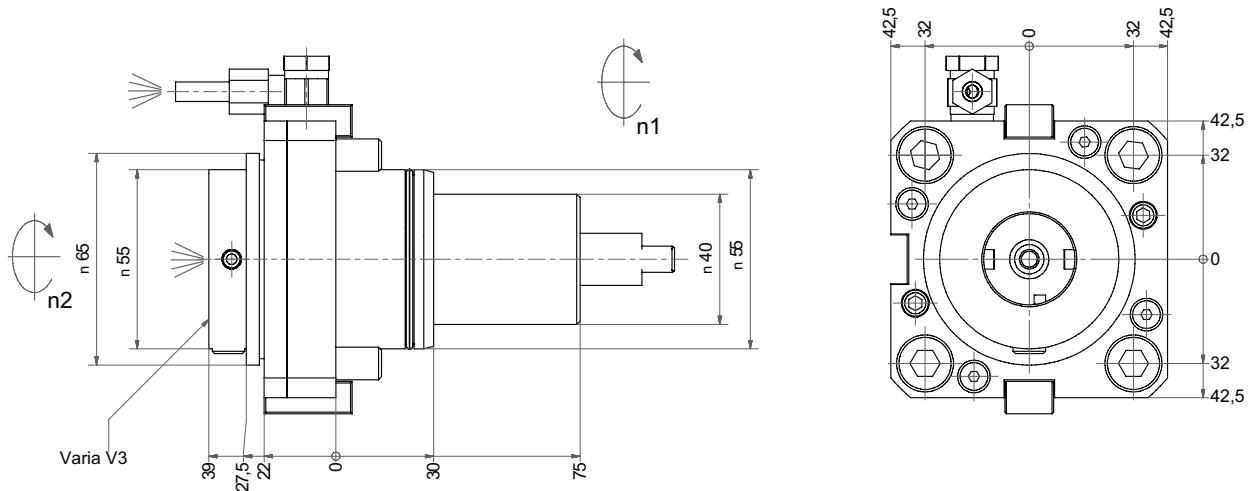

**Part No.**  
**# 80.55V31809N4-IK**

Subject to technical modifications

Coolant	i	M1	M2	n1	n2	Tooling System	X
Int. / Ext.	1:1	25 Nm	25 Nm	6000 1/min	6000 1/min	Varia V3	X=(39mm)

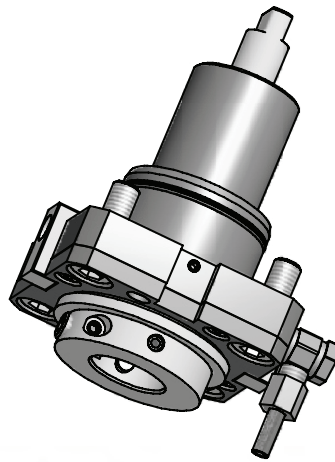

**ITI TOOLING COMPANY**

A Division of **INDEXING TECHNOLOGIES INC.**

37 Orchard Street., Ramsey, NJ. 07446 - Phone (201) 934-6333 - Fax (201) 934-6333 [www.indexingtechnologies.com](http://www.indexingtechnologies.com)  
[www.ititooling.com](http://www.ititooling.com)

## ITI - Radial (90°) Drilling and Milling Head

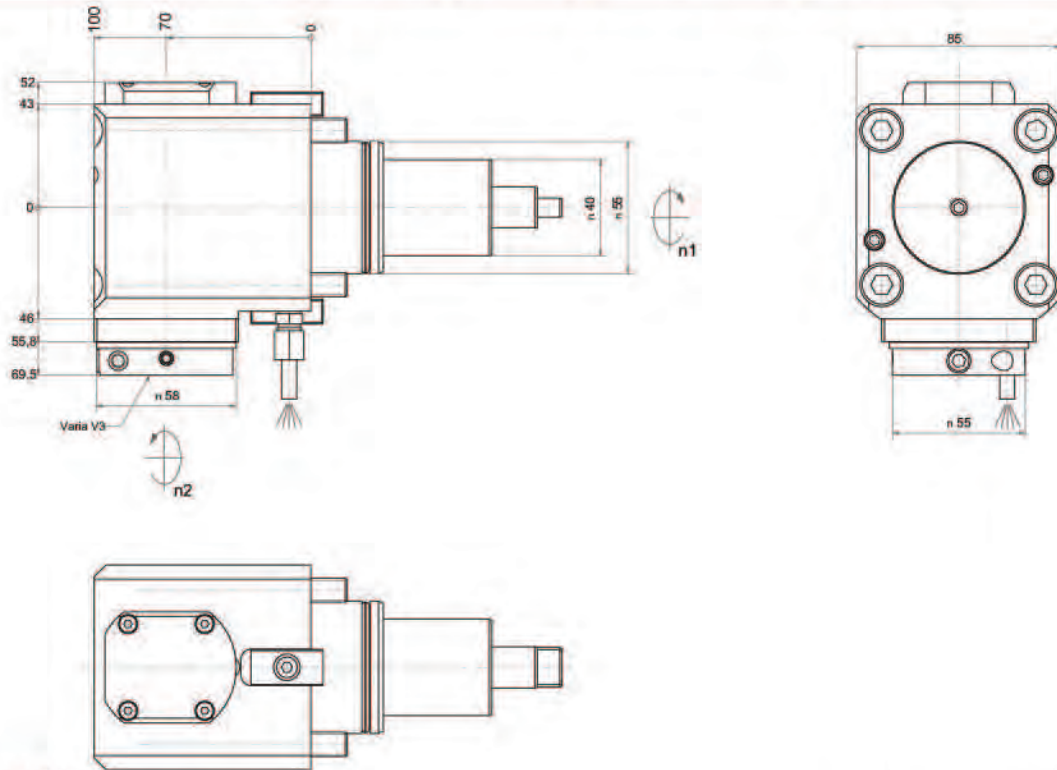

**Part No.**  
**# 60.55V31809N4**

Subject to technical modifications

Coolant	i	M1	M2	n1	n2	Tooling System	X
Ext.	1:1	25 Nm	25 Nm	6000 1/min	6000 1/min	Varia V3	X= 70mm.

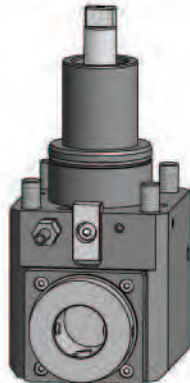

**ITI TOOLING COMPANY**

A Division of **INDEXING TECHNOLOGIES INC.**

37 Orchard Street., Ramsey, NJ. 07446 - Phone (201) 934-6333 - Fax (201) 934-6333 [www.indexingtechnologies.com](http://www.indexingtechnologies.com)  
[www.ititooling.com](http://www.ititooling.com)

## ITI - Radial (90°) Drilling and Milling Head

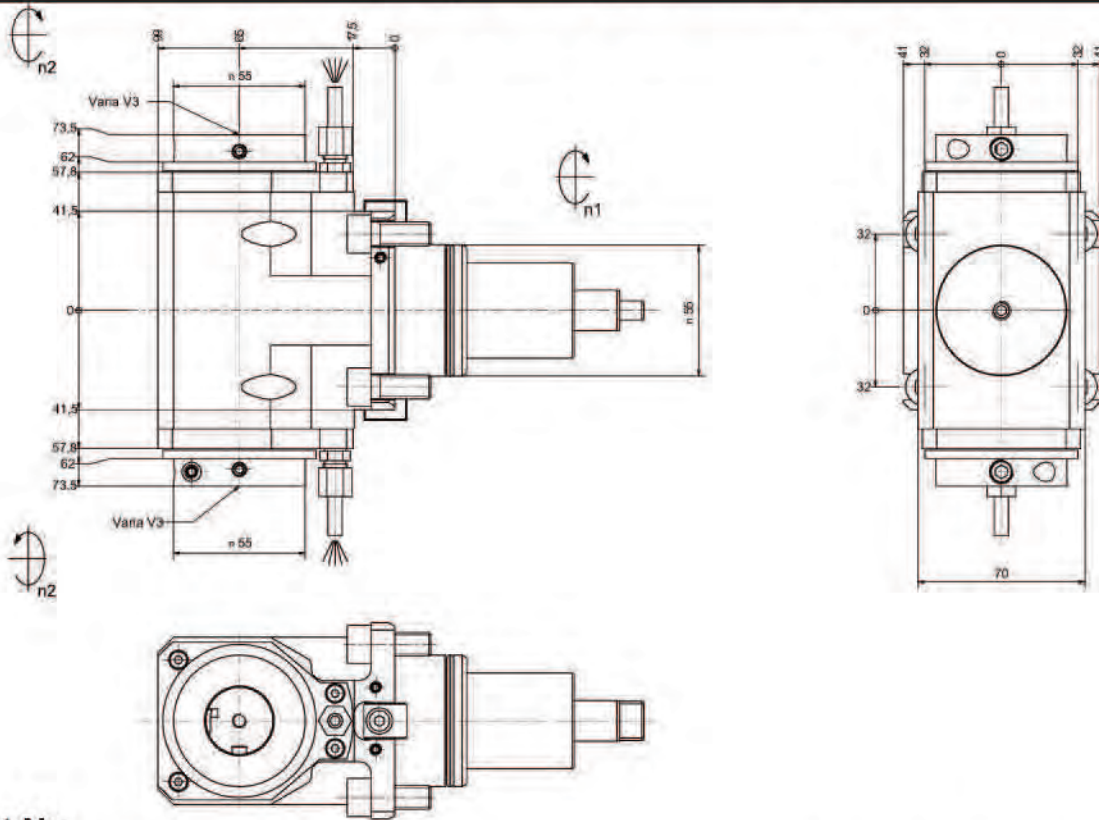

Part No.

# 60.55V3D1809N4

Subject to technical modifications

Coolant	i	M1	M2	n1	n2	Tooling System
Ext.	1:1	25 Nm	25 Nm	6000 1/min	6000 1/min	QC - Varia

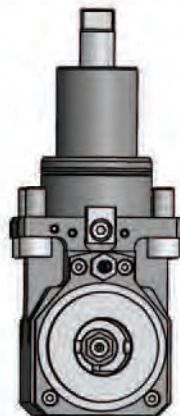

**ITI** TOOLING COMPANY

A Division of **INDEXING** TECHNOLOGIES INC.

37 Orchard Street., Ramsey, NJ. 07446 - Phone (201) 934-6333 - Fax (201) 934-6333 www.indexingtechnologies.com  
www.ititooling.com



## ITI - Radial (90°) Drilling and Milling Head

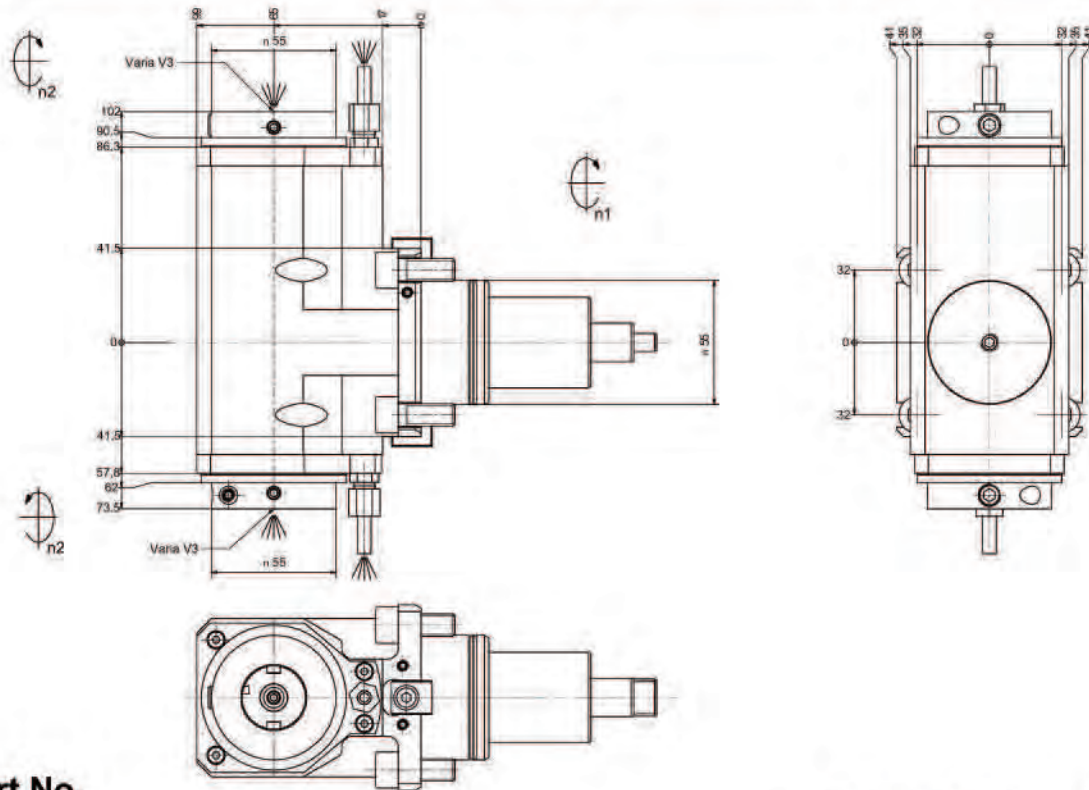

Part No.

# 60.55V3D1809N4-IK

Subject to technical modifications

Coolant	i	M1	M2	n1	n2	Tooling System
Int. / Ext.	1:1	25 Nm	25 Nm	6000 1/min	6000 1/min	QC - Varia

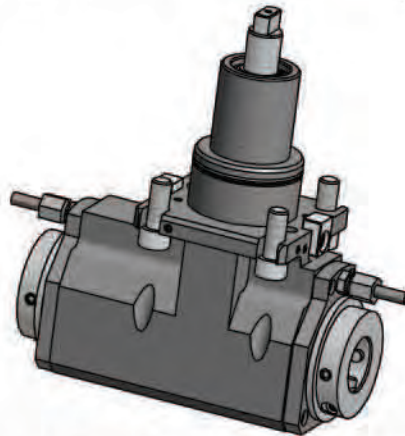

**ITI TOOLING COMPANY**

A Division of **INDEXING TECHNOLOGIES INC.**

37 Orchard Street., Ramsey, NJ. 07446 - Phone (201) 934-6333 - Fax (201) 934-6333 www.indexingtechnologies.com  
www.ititooling.com

## ITI - Collet Chuck

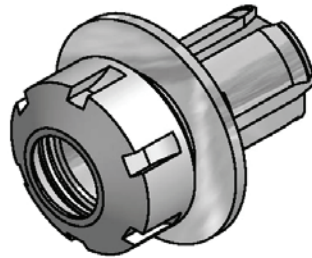
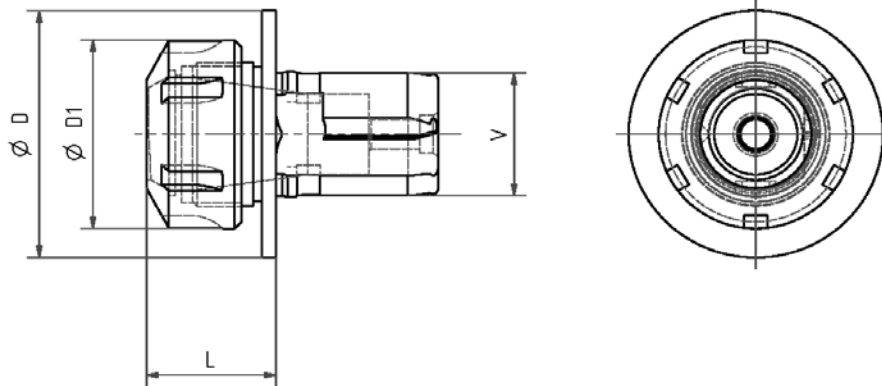

Bestell Nr. Order No.	V	D	D1	L	Spannzange Collet
31.V316L27	V3	55	28	27	160 426E ER16 (Seite/Page 1.29)
31.V316L103	V3	55	27	103	160 426E ER16 (Seite/Page 1.29)
31.V320L27	V3	55	34	27	200 428E ER20 (Seite/Page 1.29)
31.V325L30	V3	55	42	30	250 430E ER25 (Seite/Page 1.29)
31.V325L60	V3	55	42	60	250 430E ER25 (Seite/Page 1.29)
31.V332L63	V3	55	50	63	320 470E ER32 (Seite/Page 1.29)
31.V416L23,5	V4	65	28	23,5	160 426E ER16 (Seite/Page 1.29)
31.V416L50	V4	65	28	50	160 426E ER16 (Seite/Page 1.29)
31.V420L25	V4	65	34	25	200 428E ER20 (Seite/Page 1.29)
31.V420L50	V4	65	34	50	200 428E ER20 (Seite/Page 1.29)
31.V425L28	V4	65	42	30	250 430E ER25 (Seite/Page 1.29)
31.V432L30	V4	65	50	30	320 470E ER32 (Seite/Page 1.29)
31.V432L35	V4	65	50	35	320 470E ER32 (Seite/Page 1.29)



**ITI TOOLING COMPANY**

A Division of **INDEXING TECHNOLOGIES INC.**

## ITI - Collet Chuck

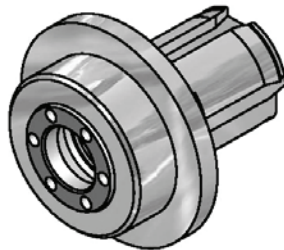
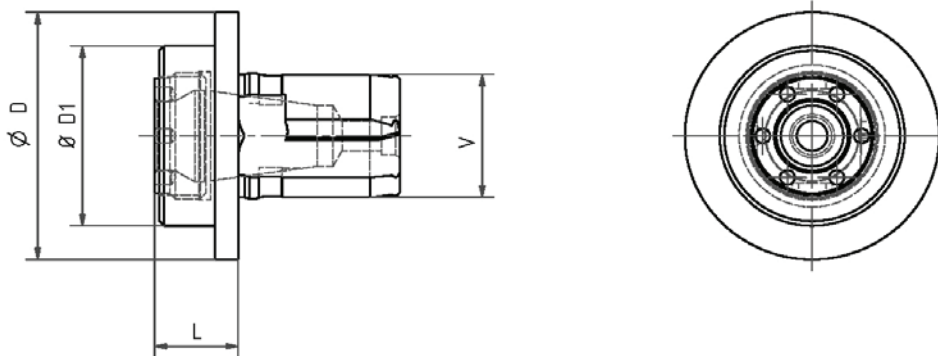

Bestell Nr. Order No.	V	D	D1	L	Spannzange Collet
31.V316IML14	V3	55	34	14	160 426E ER16 (Seite/Page 1.29)
31.V320IML17	V3	55	40	18	200 428E ER20 (Seite/Page 1.29)



**ITI TOOLING COMPANY**

A Division of **INDEXING TECHNOLOGIES INC.**

37 Orchard Street., Ramsey, NJ. 07446 - Phone (201) 934-6333 - Fax (201) 934-6333 [www.indexingtechnologies.com](http://www.indexingtechnologies.com)  
[www.ititooling.com](http://www.ititooling.com)



## ITI - Weldon/Whistle Notch Insert

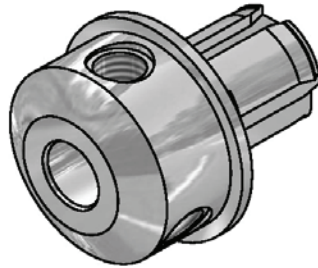
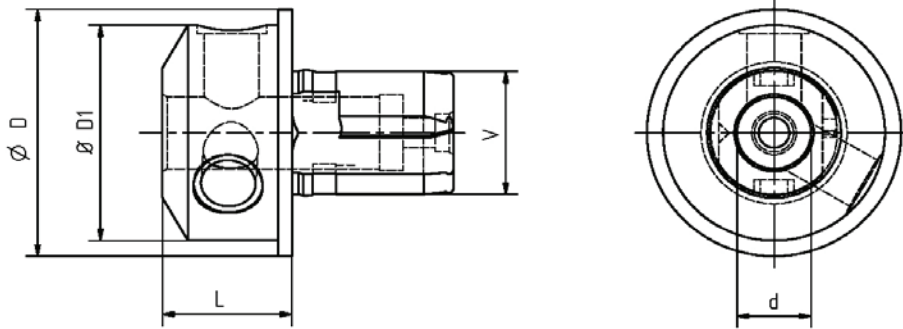

Bestell Nr. Order No.	V	D	D1	L	d
27.V306WNL16	V3	55	25	16	06
27.V308WNL17	V3	55	25	17	08
27.V309,53WNL26	V3	55	42	26	09,53
27.V310WNL26	V3	55	42	26	10
27.V312WNL26	V3	55	42	26	12
27.V314WNL28	V3	55	48	28	14
27.V315,88WNL28	V3	55	48	28	15,88
27.V316WNL28	V3	55	48	28	16
27.V318WNL28	V3	55	52	28	18
27.V406WNL16	V4	65	25	16	06
27.V408WNL19	V4	65	25	19	08
27.V410WNL26	V4	65	42	26	10
27.V412WNL28	V4	65	42	28	12
27.V414WNL28	V4	65	48	28	14
27.V416WNL28	V4	65	48	28	16
27.V418WNL28	V4	65	52	28	18
27.V420WNL28	V4	65	52	28	20
27.V425WNL33	V4	65	60	33	25



**ITI TOOLING COMPANY**

A Division of **INDEXING TECHNOLOGIES INC.**

37 Orchard Street., Ramsey, NJ. 07446 - Phone (201) 934-6333 - Fax (201) 934-6333 [www.indexingtechnologies.com](http://www.indexingtechnologies.com)  
[www.ititooling.com](http://www.ititooling.com)

## ITI - Milling Insert

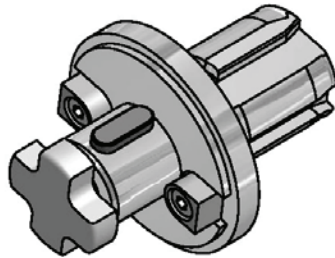
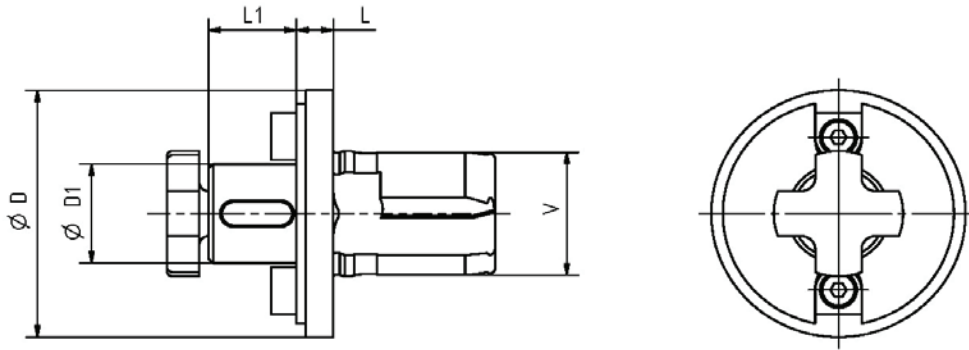

Bestell Nr. Order No.	V	L	L1	D	D1
42.V308L28	V3	28	12	55	08
42.V310L28	V3	28	12	55	10
42.V313L08,5	V3	08,5	12	55	13
42.V316L08	V3	08	17	55	16
42.V322L08	V3	08	19	55	22
42.V327L08	V3	08	21	55	27
42.V416L08	V4	08	17	65	16
42.V422L08	V4	08	19	65	22
42.V427L08	V4	08	21	65	27



**ITI TOOLING COMPANY**

A Division of **INDEXING TECHNOLOGIES INC.**

37 Orchard Street., Ramsey, NJ. 07446 - Phone (201) 934-6333 - Fax (201) 934-6333 [www.indexingtechnologies.com](http://www.indexingtechnologies.com)  
[www.ititooling.com](http://www.ititooling.com)

## ITI - Hydrodehn Insert

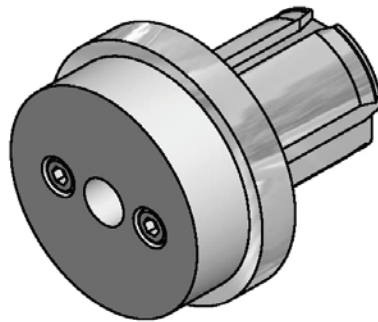
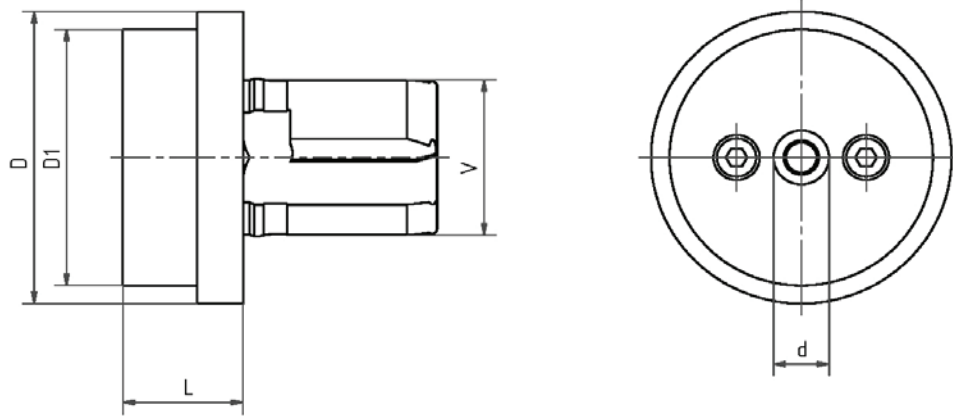

Bestell Nr.	V	D	D1	L	d
27.V312HYDL26	V3	55	57	26	12
27.V412HYDL26	V4	65	57	26	12



**ITI TOOLING COMPANY**

A Division of **INDEXING TECHNOLOGIES INC.**

37 Orchard Street., Ramsey, NJ. 07446 - Phone (201) 934-6333 - Fax (201) 934-6333 [www.indexingtechnologies.com](http://www.indexingtechnologies.com)  
[www.ititooling.com](http://www.ititooling.com)



## ITI - Floating Tool Holder Collet Chuck

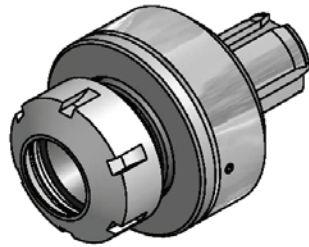
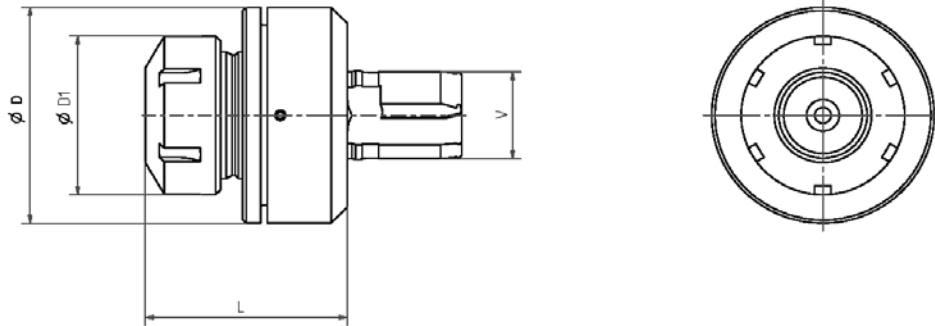

Bestell Nr. Order No.	V	D	D1	L	Spannzange Collet
PH-31.V332L63	V3	68	50	63	320 470E ER32 (Seite/Page 1.29)



**ITI TOOLING COMPANY**

A Division of **INDEXING TECHNOLOGIES INC.**

37 Orchard Street., Ramsey, NJ. 07446 - Phone (201) 934-6333 - Fax (201) 934-6333 [www.indexingtechnologies.com](http://www.indexingtechnologies.com)  
[www.ititooling.com](http://www.ititooling.com)

## ITI - Morse Taper Adaptor

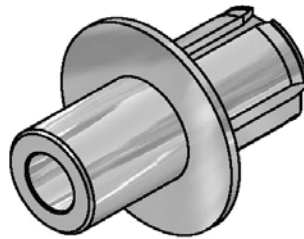
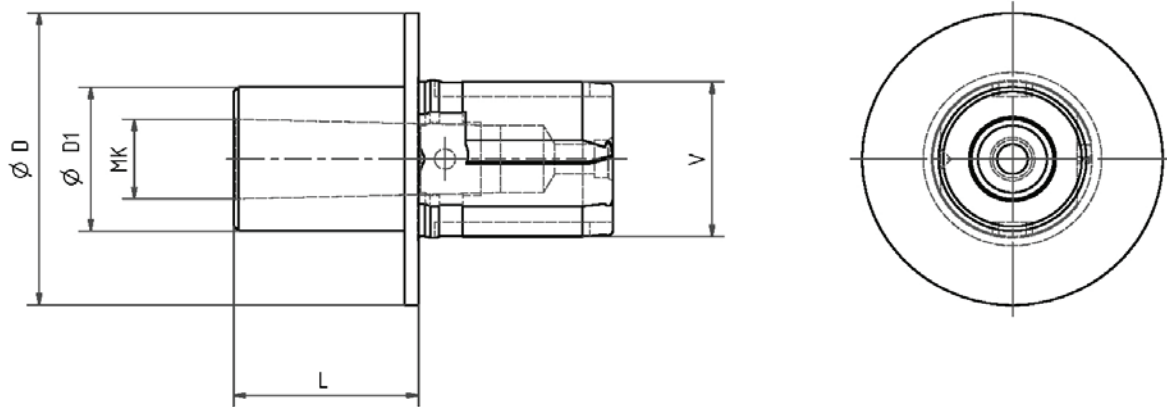

Bestell Nr. Order No.	V	D	D1	L	MK
25.V410L30	V4	65	25	63	1
25.V420L40	V4	65	32	32	2



**ITI** TOOLING COMPANY

A Division of **INDEXING** TECHNOLOGIES INC.

37 Orchard Street., Ramsey, NJ. 07446 - Phone (201) 934-6333 - Fax (201) 934-6333 [www.indexingtechnologies.com](http://www.indexingtechnologies.com)  
[www.ititooling.com](http://www.ititooling.com)

