



# CNC Rotary Tables

## Product Catalog

[WWW.INDEXINGTECHNOLOGIES.COM](http://WWW.INDEXINGTECHNOLOGIES.COM)



ACCESSORI PER MACCHINE UTENSILI

[www.lcmitalia.it](http://www.lcmitalia.it)



## LA TRASMISSIONE THE TRANSMISSION

Il sistema vite corona  
Worm-Gear system

Ottima rigidità e precisione elevata  
Optimal rigidity and higher precision

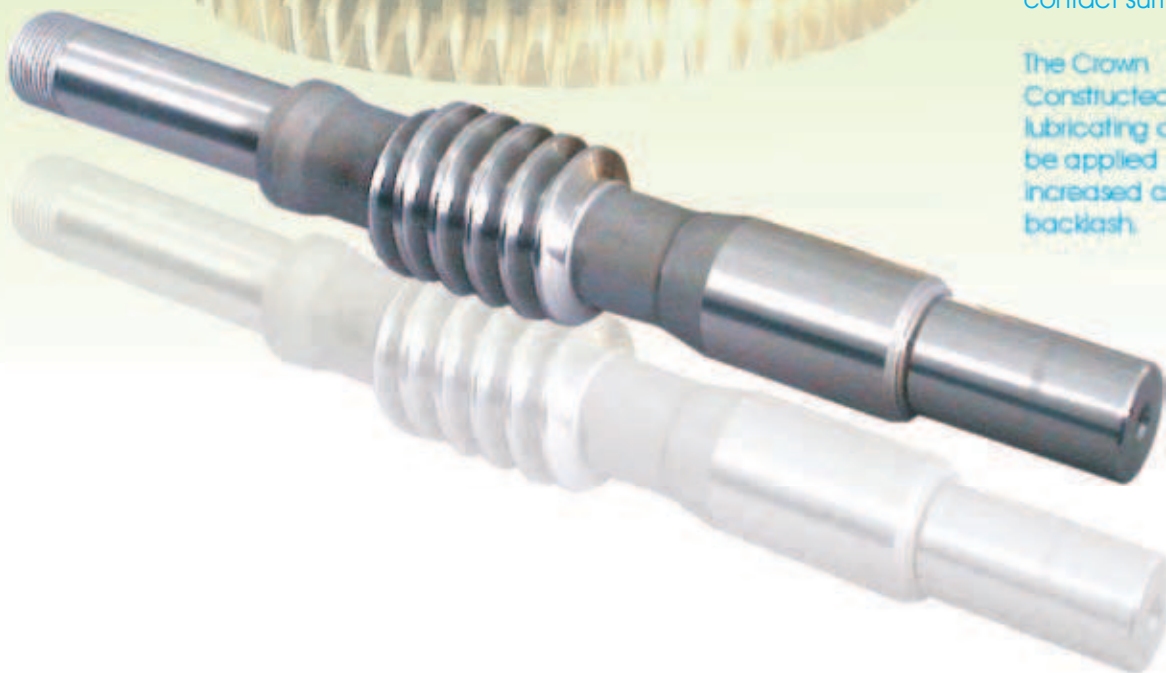
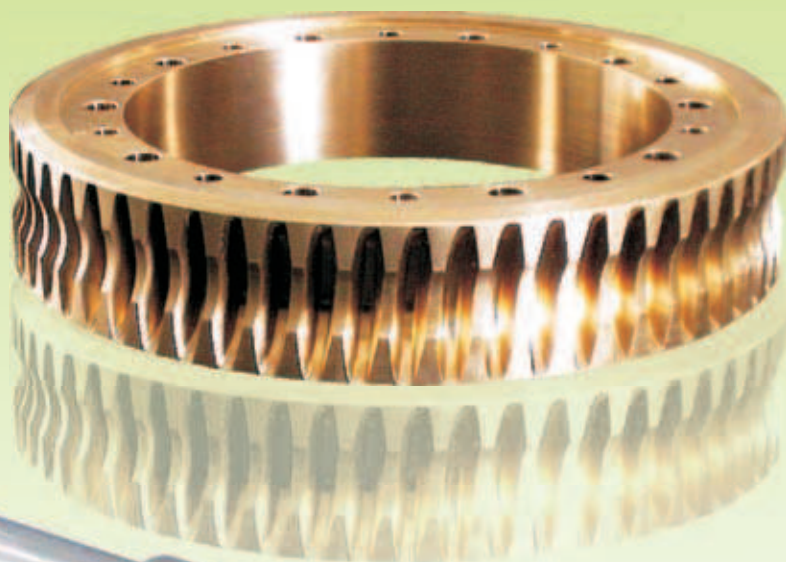

### La Vite Senza Fine

Viene utilizzata una vite senza fine in acciaio cementato e temprato con un profilo particolare che garantisce un'ottima ampiezza di superficie di contatto.

### La Corona

Il materiale costruttivo è il bronal, una lega autolubrificante che consente di applicare un precarico a tutte le tavole LCM, per una migliore precisione dinamica ed un annullamento del gioco di inversione.

### The Worm-screw

Utilising a worm-screw made of cemented and hardened steel having a unique precision ground profile that guarantees a wide contact surface.

### The Crown

Constructed from bronal, this self-lubricating alloy allows a preload to be applied to all LCM tables for increased dynamic accuracy and no backlash.

Il motore coppia  
Torque motor

Velocità elevate ed assenza di giochi  
High speed, zero backlash



L.C.M. produce una vasta gamma di tavole con motori torque. Questa tecnologia consente alla LCM di costruire tavole con capacità di coppia in lavoro simili a tavole con sistema vite corona ma con velocità di rotazione molto elevate. Un altro importante vantaggio è l'assenza di giochi di inversione e conseguente risposta dinamica elevata e precisione, grazie alla risposta bi-direzionale rapida. Le tavole con motori coppia hanno necessità di avere un sistema di raffreddamento interno, normalmente a liquido, che aumenta la coppia e riduce l'espansione termica. Dotate di un encoder montato diretto in asse di rotazione, queste tavole garantiscono una precisione di posizionamento estremamente accurata.

L.C.M. produces a wide range of tables with torque motors. This technology allows LCM to build tables with similar working torque to the worm/gear system, but with higher rotational speeds. Another important advantage is the elimination of backlash providing high dynamic response and accuracy thanks to rapid bi-directional response. Liquid cooling increases torque and reduces thermal expansion. Equipped with a directly mounted rotary encoder, these tables provide extremely precise position accuracy.

Carter a tenuta stagna mediante guarnizioni Oring. Sistema di pressurizzazione forzata.

Fully sealed sumps (covers) thanks to Oring seals. Forced pressurisation system.

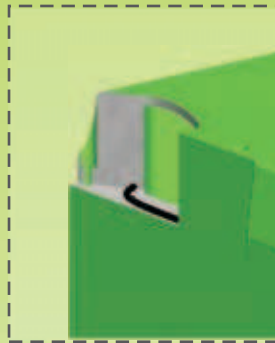

I corpi delle tavole sono costruiti con una lega speciale avente elevata resistenza meccanica e caratteristiche superiori a ghisa ed acciaio. Il peso della tavola è ridotto con conseguente minor usura ed espansione termica delle viti a ricircolo del banco mobile della macchina utensile.

The table is made from a special alloy having high mechanical strength and features superior to steel or cast iron. Table load is reduced resulting in less wear and thermal expansion of machine tool ballscrews.

Cuscinetti a rulli incrociati

Crossed rollers bearings



Piattello cementato e temprato

Cemented and hardened disk

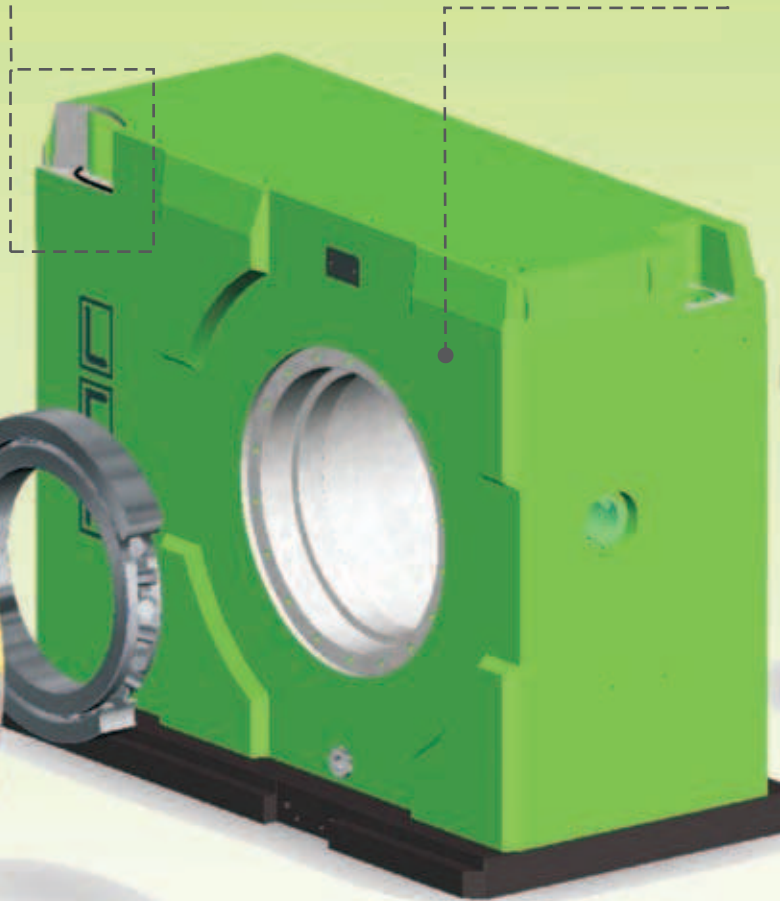

Sistema di bloccaggio Heavy-Block®  
Coppie elevatissime senza necessità di centraline idrauliche

Heavy-Block® clamping system.  
High clamping torque achieved without the use of hydraulic units

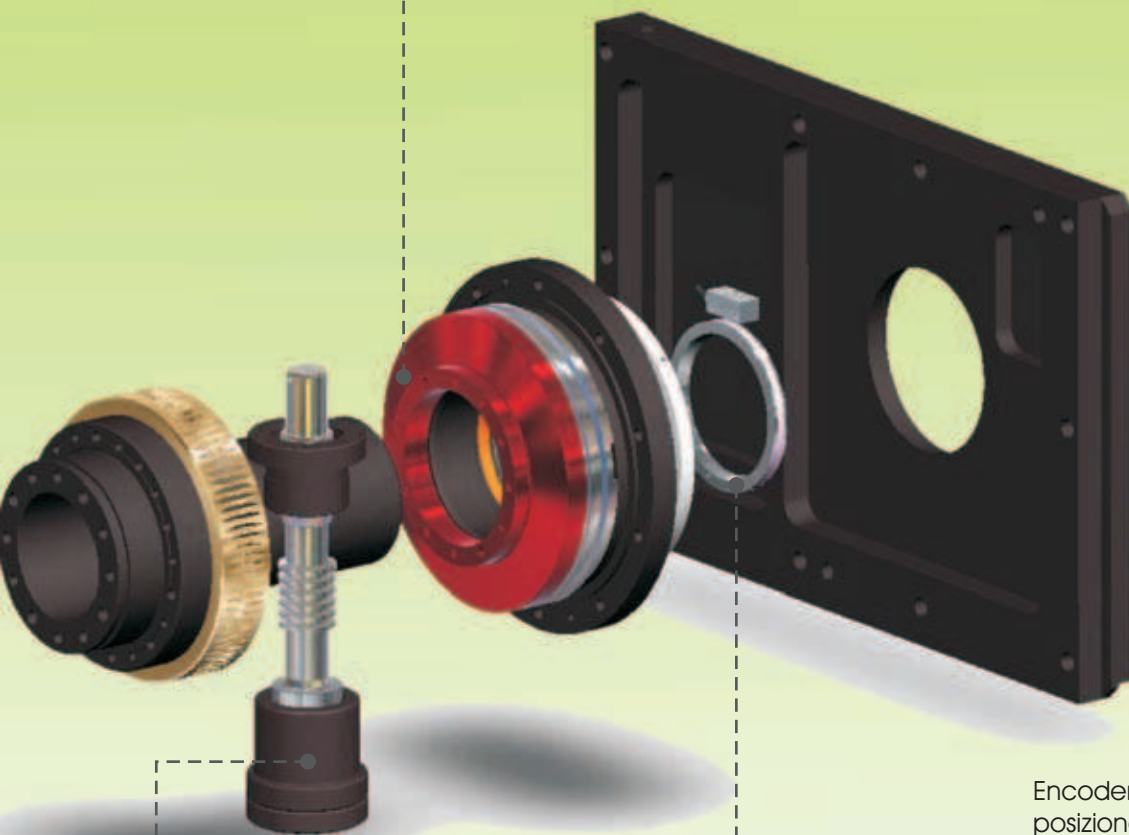
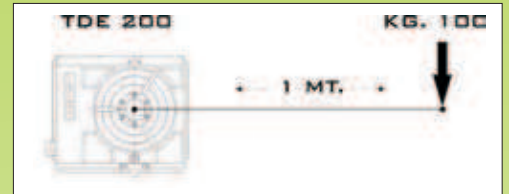

Encoder ottico per lettura di posizionamento diretta in asse di rotazione.(optional)

Direct in-axis encoder (optional)

In fase di assemblaggio delle tavole, tutti i gruppi vite-corona vengono rodati per 40 ore. Al sistema viene successivamente applicato un "precarico" che garantisce l'assenza totale di gioco di inversione.

During assembly, all tables undergo a 40 hour run-in to ensure final production accuracy. Tables then have a pre-load applied and a final test inspection.

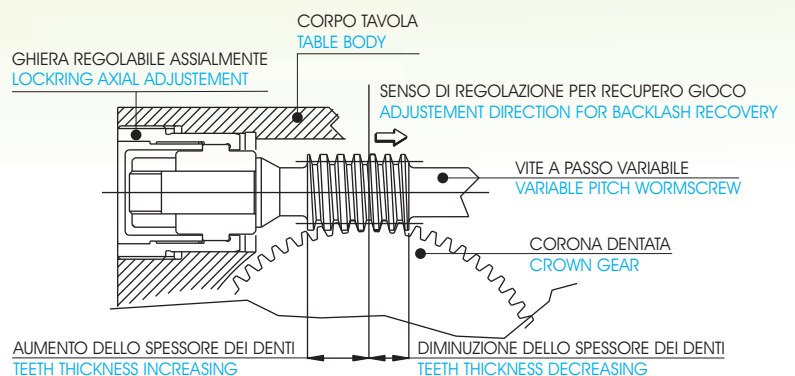

### Tavole girevoli cnc

Posizionamento verticale ed orizzontale  
Trasmissione meccanica - Bloccaggio pneumatico

TDE

### CNC Rotary tables

Vertical-horizontal positioning  
Mechanical transmission - Pneumatic clamping

P. 8



### Tavole girevoli cnc con inclinazione manuale

Posizionamento asse inclinabile con volantino  
Trasmissione meccanica - Bloccaggio pneumatico asse girevole

BAS-V

### CNC Rotary tables with manual tilting

Tilting axis positioning by handwheel  
Mechanical transmission - Rotary axis pneumatic clamping

P. 10



### Tavole roto-basculanti cnc

Trasmissione meccanica  
Bloccaggio pneumatico

BSC

### CNC Tilting rotary tables

Mechanical transmission  
Pneumatic clamping

P. 12



### Tavole multiple roto-basculanti cnc

Movimento simultaneo assi girevoli  
Trasmissione meccanica - Bloccaggio pneumatico

MTX

### CNC multipindle rotary tilting tables

Simultaneous control of multiple rotating spindles  
Mechanical transmission - Pneumatic clamping

P. 14



### Tavole roto-basculanti cnc

Specifica per macchine ad elettroerosione  
Trasmissione meccanica

BSL

### CNC Tilting rotary tables

Designed and made for EDM machines  
Mechanical transmission

P. 16



### Tavole girevoli cnc

Posizionamento orizzontale sulla tavola della macchina  
Trasmissione meccanica - Bloccaggio idraulico

TDE-M TRB-M

### CNC rotary tables

Horizontal positioning on machine table  
Mechanical transmission - Hydraulic clamping

P. 18



### Tavole roto-basculanti cnc

Specifiche per macchine a 5 assi  
Trasmissione meccanica - Bloccaggio idraulico

BRS-MM

### CNC Tilting rotary tables

Designed and made for 5 axis machines  
Mechanical transmission - Hydraulic clamping

P. 19



**Tavole roto-basculanti cnc**

Specifiche per macchine a 5 assi  
Trasmissione meccanica - Bloccaggio idraulico

**CNC Tilting rotary tables**

Designed and made for 5 axis machines  
Mechanical transmission - Hydraulic clamping

BRC-M

P. 20



**Tavole girevoli cnc**

Posizionamento verticale  
Motore coppia - Bloccaggio idraulico

**CNC rotary tables**

Vertical positioning  
Torque motor - Hydraulic clamping

TDE-T

P. 22



**Tavole girevoli cnc**

Posizionamento orizzontale sulla tavola della macchina  
Motore coppia - Bloccaggio idraulico

**CNC rotary tables**

Horizontal positioning on machine table  
Torque motor - Hydraulic clamping

TDE-T

P. 22



**Tavole girevoli cnc**

Posizionamento orizzontale integrato nella tavola della macchina  
Motore coppia - Bloccaggio idraulico

**CNC rotary tables**

Horizontal positioning inside the machine table  
Torque motor - Hydraulic clamping

TRB-T

P. 24



**Tavole roto-basculanti cnc**

Specifiche per macchine a 5 assi  
Motore coppia - Bloccaggio idraulico

**CNC Tilting rotary tables**

Designed and made for 5 axis machines  
Torque motor - Hydraulic clamping

BRC-T

P. 26



**Teste di fresatura tiltanti**

Trasmissione meccanica  
Bloccaggio idraulico

**Tilting heads for milling**

Mechanical transmission  
Hydraulic clamping

MD-M

P. 28



**Accessori ed opzioni**

Controlli numerici - Motori - Contropunte  
Autocentranti - Controsupporti - Encoder

**Accessories and options**

NC for tables control - Motors - Tailstocks  
Chucks - Support spindles - encoders

P. 36







## Tavole girevoli cnc Cnc Rotary tables

Posizionamento asse verticale-orizzontale  
Trasmissione meccanica  
Bloccaggio pneumatico

Vertical-horizontal positioning  
Mechanical transmission  
Pneumatic clamping



Caratteristiche - Modelli Specifications - Models		TDE 125	TDE 200	TDE 250	TDE 350
Diámetro tavola Table diameter	mm.	125	198	248	348 (398 Opt.)
Diámetro foro centrale Center bore	mm.	28	42	81	101
Altezza punta Center height	mm.	110	151	180	225
Larghezza cave a T Table T-slots width	mm.	6	9,7	11,7	13,7
Sistema di bloccaggio Clamp system		Pneumatico Pneumatic	Pneumatico Pneumatic	Pneumatico Pneumatic	Pneumatico Pneumatic
Capacità di bloccaggio Clamp torque	Nm.	250	400	620	1000
Rapporto vite/corona Worm screw/wheel ratio		1/90	1/90	1/60	1/60
Rapporto vite/motore Worm screw/motor ratio		1/2	1/2	1/2	1/2
Grandezza motore (pagina 43) Servo motor size (page 43)		1	2	3	4
Velocità massima di rotazione Max rotation speed	Rpm	16,6	16,6	25	25
Precisione di posizionamento Indexing accuracy	sec.	±15	±15	±15	±15
Incremento minimo Minimum increase		0,001°	0,001°	0,001°	0,001°
Peso max ammesso verticale Max allowable load vertical	 Kg.	80	100	270	800
Peso max ammesso orizzontale Max allowable load horizontal	 Kg.	150	195	560	1000
Spinta max ammessa verticale Max allowable thrust vertical	 FxL Nm	300	950	1700	2200
Spinta max ammessa orizzontale Max allowable thrust horizontal	 N.	6000	12000	23000	38000
Coppia di lavoro Working torque	 Nm	124	194	336	670
Peso netto tavola Table net weight	Kg.	30	57	98	230



TDE 125

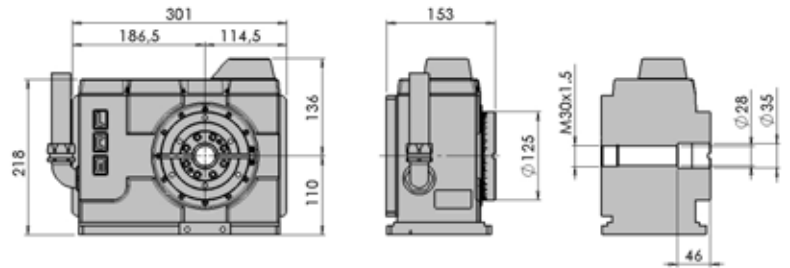

TDE 200

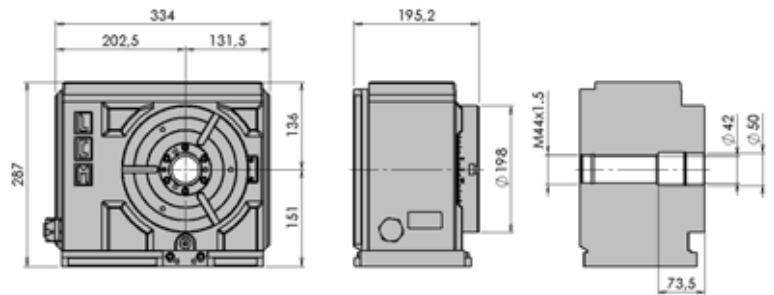

TDE 250

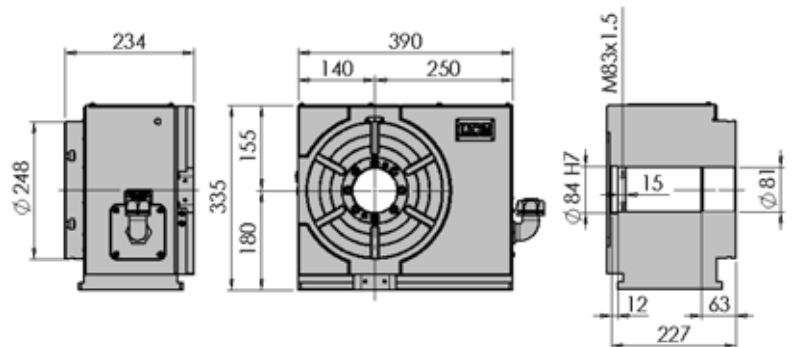

TDE 350

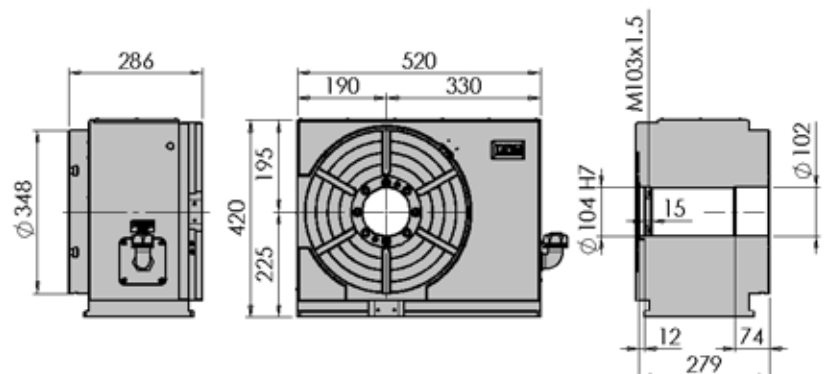

# BAS-V 125 - 200 -250 - 320







## Tavole girevoli cnc con inclinazione manuale Cnc Rotary tables with manual tilting

Posizionamento asse inclinabile con volantino  
Trasmissione meccanica  
Bloccaggio pneumatico asse girevole  
Bloccaggio meccanico manuale asse inclinabile

Tilting axis positioning by handwheel  
Mechanical transmission  
Rotary axis pneumatic clamping  
Tilting axis manual mechanical clamping



Caratteristiche - Modelli Specifications - Models		BAS-V 125		BAS-V 200		BAS-V 250		BAS-V 320	
Diámetro tavola Table diameter	mm.	125		198		248		318	
Diámetro foro centrale Center bore	mm.	28		42		72		81	
Altezza punta Center height	mm.	127		151		180		235	
Larghezza cave a T Table T-slots width	mm.	6		9,7		11,7		13,7	
Inclinazione Tilt range		-15° ÷ 110°		-10° ÷ 110°		-10° ÷ 100°		-10° ÷ 100°	
Asse Axis		Girevole Rotary	Inclinabile Tilting	Girevole Rotary	Inclinabile Tilting	Girevole Rotary	Inclinabile Tilting	Girevole Rotary	Inclinabile Tilting
Sistema di bloccaggio Clamp system		Pneumatico Pneumatic	Manuale Manual	Pneumatico Pneumatic	Manuale Manual	Pneumatico Pneumatic	Manuale Manual	Pneumatico Pneumatic	Manuale Manual
Capacità di bloccaggio Clamp torque	Nm.	250	600	400	800	600	1000	1000	1500
Rapporto vite/corona Worm screw/wheel ratio		1/180	---	1/180	---	1/180	---	1/180	---
Grandezza motore (pagina 43) Servo motor size (page 43)		1	---	2	---	3	---	4	---
Velocità massima di rotazione Max rotation speed	Rpm	16,6	---	16,6	---	16,6	---	16,6	---
Precisione di posizionamento Indexing accuracy	sec.	± 15	± 30	± 15	± 30	± 15	± 30	± 15	± 30
Incremento minimo Minimum increase		0,001°		0,001°		0,001°		0,001°	
Peso max ammesso 0° Max allowable load 0°	 Kg.	45		85		130		220	
Peso max ammesso 90° Max allowable load 90°	 Kg.	25		45		90		140	
Spinta max ammessa 0° Max allowable thrust 0°	 N.	4600		6200		10300		13100	
Spinta max ammessa 90° Max allowable thrust 90°	 FxL Nm	160		350		650		830	
Coppia di lavoro Working torque	 Nm	124		194		254		630	
Peso netto tavola Table net weight	Kg.	56		88		125		278	

Tavole girevoli cnc con inclinazione manuale  
*Cnc Rotary tables with manual tilting*

**BAS-V 125**

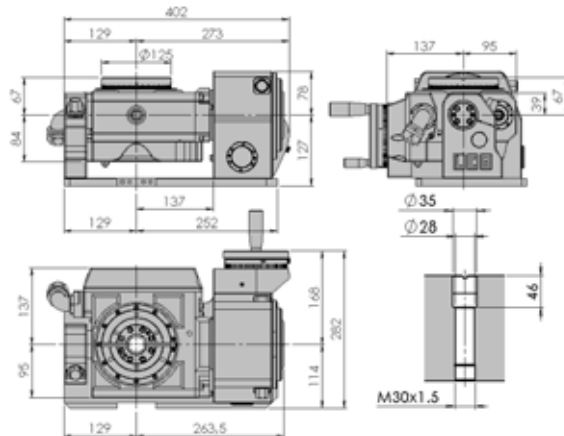

**BAS-V 200**

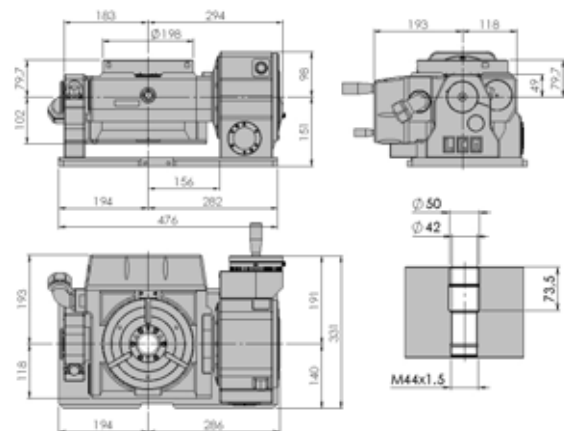

**BAS-V 250**

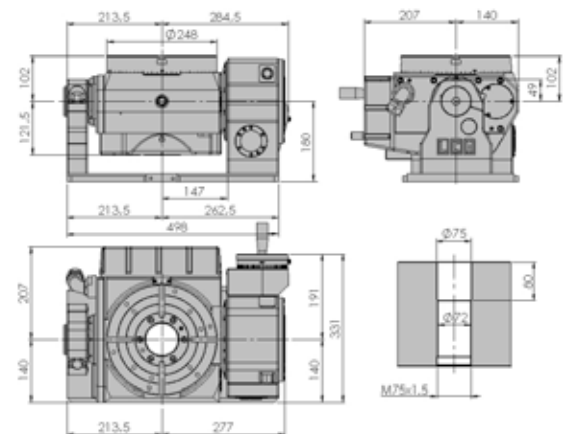

**BAS-V 320**

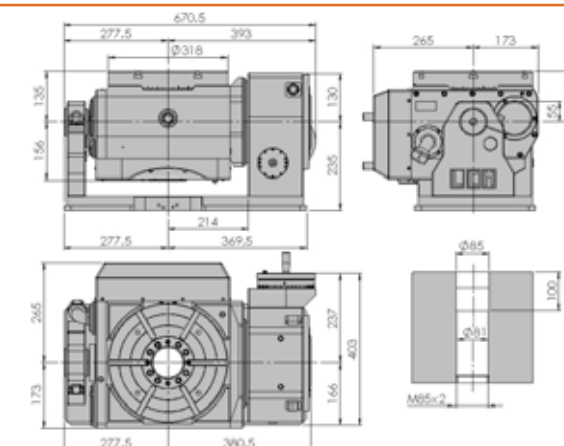

## Tavole roto-basculanti cnc CNC Tilting rotary tables

Trasmissione meccanica  
Bloccaggio pneumatico

Mechanical transmission  
Pneumatic clamping



Caratteristiche - Modelli Specifications - Models		BSC 125		BSC 200		BSC 250		BSC 320	
Diámetro tavola Table diameter	mm.	125		198		248		318	
Diámetro foro centrale Center bore	mm.	28		42		72		81	
Altezza punta Center height	mm.	127		151		180		235	
Larghezza cave a T Table T-slots width	mm.	6		9,7		11,7		13,7	
Inclinazione Tilt range		-10° ÷ 110°		-10° ÷ 110°		-10° ÷ 100°		-10° ÷ 100°	
Asse Axis		Girevole Rotary	Inclinabile Tilting	Girevole Rotary	Inclinabile Tilting	Girevole Rotary	Inclinabile Tilting	Girevole Rotary	Inclinabile Tilting
Sistema di bloccaggio Clamp system		Pneumatico Pneumatic	Pneumatico Pneumatic	Pneumatico Pneumatic	Pneumatico Pneumatic	Pneumatico Pneumatic	Pneumatico Pneumatic	Pneumatico Pneumatic	Pneumatico Pneumatic
Capacità di bloccaggio Clamp torque	Nm.	250	400	400	600	600	1200	1000	1600
Rapporto vite/corona Worm screw/wheel ratio		1/180	1/180	1/180	1/120	1/180	1/180	1/180	1/240
Grandezza motore (pagina 43) Servo motor size (page 43)		1	1	2	3	3	3	4	4
Velocità massima di rotazione Max rotation speed	Rpm	16,6	16,6	16,6	25	16,6	16,6	16,6	12,5
Precisione di posizionamento Indexing accuracy	sec.	± 15	± 30	± 15	± 30	± 15	± 30	± 15	± 30
Incremento minimo Minimum increase		0,001°		0,001°		0,001°		0,001°	
Peso max ammesso 0° Max allowable load 0°	Kg.	45		95		130		220	
Peso max ammesso 90° Max allowable load 90°	Kg.	25		45		90		110	
Spinta max ammessa 0° Max allowable thrust 0°	N.	4600		8600		10300		13100	
Spinta max ammessa 90° Max allowable thrust 90°	FxL Nm	125		370		650		830	
Coppia di lavoro Working torque	Nm	124		194		254		630	
Peso netto tavola Table net weight	Kg.	58		88		140		322	

**BSC 125**

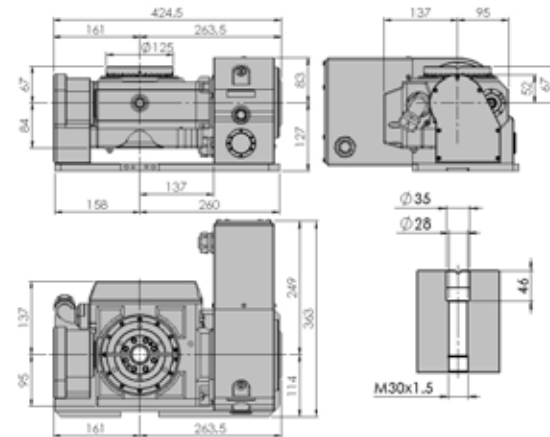

**BSC 200**

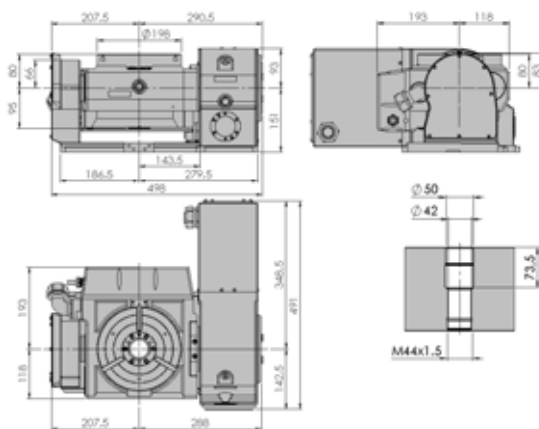

**BSC 250**

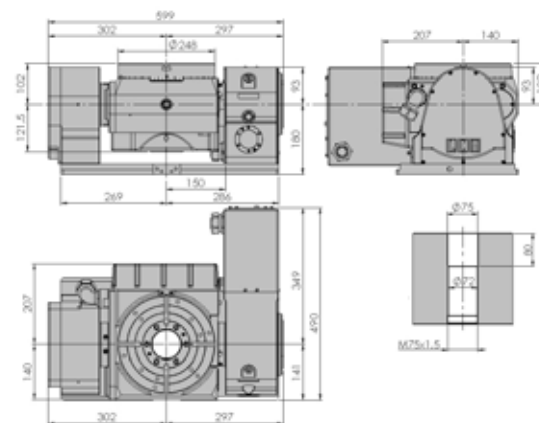

**BSC 320**

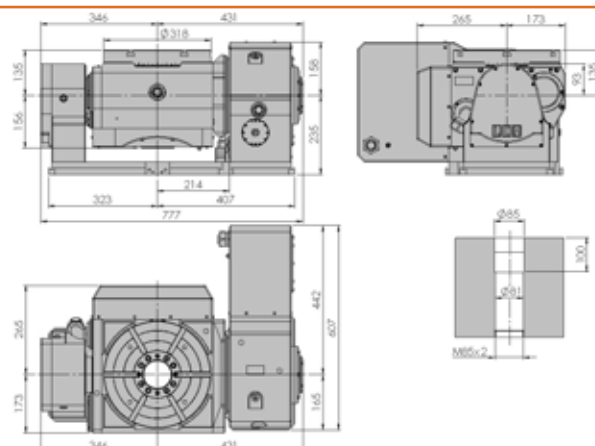





## Tavole multiple roto-basculanti cnc CNC multipindle rotary tilting tables

Movimento simultaneo assi girevoli  
Trasmissione meccanica  
Bloccaggio pneumatico

Simultaneous control of multiple rotating spindles  
Mechanical transmission  
Pneumatic clamping



Caratteristiche - Modelli Specifications - Models		MTX 125-3		MTX 125-4	
Diámetro tavola Table diameter	mm.	125		125	
Diámetro foro centrale Center bore	mm.	28		28	
Altezza punta Center height	mm.	271		271	
Larghezza cave a T Table T-slots width	mm.	6		6	
Inclinazione Tilt range		-10°÷100°		-10°÷100°	
Asse Axis		Girevole Rotary	Inclinabile Tilting	Girevole Rotary	Inclinabile Tilting
Sistema di bloccaggio Clamp system		Pneumatico Pneumatic	Pneumatico Pneumatic	Pneumatico Pneumatic	Pneumatico Pneumatic
Capacità di bloccaggio Clamp torque	Nm.	250	1000	250	1000
Rapporto vite/corona Worm screw/wheel ratio		1/234	1/180	1/234	1/180
Grandezza motore (pagina 43) Servo motor size (page 43)		2	3	2	3
Velocità massima di rotazione Max rotation speed	Rpm	12,8	16,6	12,8	16,6
Precisione di posizionamento Indexing accuracy	sec.	± 30	± 30	± 30	± 30
Incremento minimo Minimum increase		0,001°		0,001°	
Peso max ammesso 0° Max allowable load 0°	 Kg.	40		40	
Peso max ammesso 90° Max allowable load 90°	 Kg.	30		30	
Spinta max ammessa 0° Max allowable thrust 0°	 N.	3200		3200	
Spinta max ammessa 90° Max allowable thrust 90°	 FxL Nm	650		650	
Coppia di lavoro Working torque	 Nm	190		190	
Peso netto tavola Table net weight	Kg.	170		195	

**MTX 125-3**

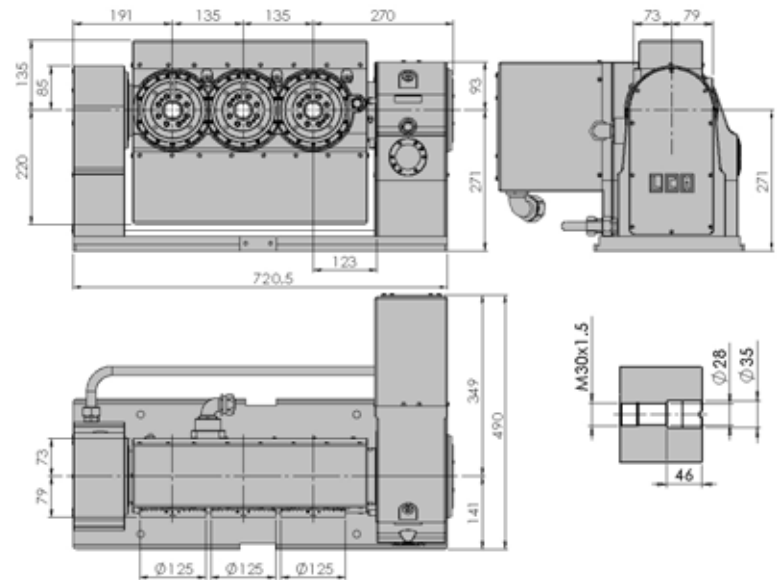

**MTX 125-4**

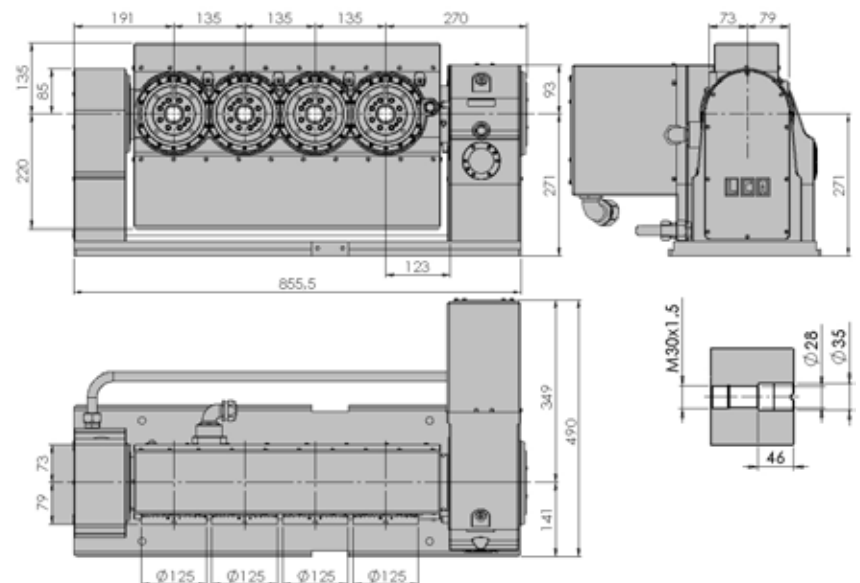

## Tavole roto-basculanti per macchine EDM CNC rotary tilting tables for EDM machines

Trasmissione meccanica  
Mechanical transmission



Tavole adatte all'utilizzo su macchine EDM per eseguire lavorazioni in completa Immersione in liquido dielettrico.

Principali caratteristiche:

Struttura interamente costruita con materiali anti-ossidanti (inox e lega anodizzata)

Precisioni di posizionamento monitorate con encoder in asse (fino a  $\pm 2,5$  sec.)

Motori brushless digitali a bassa tensione

Carter a tenuta stagna mediante guarnizioni oring

Predisposizione per fissaggio dei mandrini porta pallet più diffusi

Possibilità di gestione mediante CN LCM WNC 50 2AX®.

Tables suitable to be used on EDM machines to effect machining operations completely immersed in dielectric fluid.

Most important features:

Structure fully made of antioxydant materials (stainless steel and anodized alloy)

Indexing accuracy monitored by in-axis encoder (up to  $\pm 2,5$  sec.)

Low tension digital brushless motors

Fully sealed sump thanks to o-ring seals

Suitable for fixing the most important chucks for pallets

Possibility to be controlled by LCM WNC 50 2 AX® NC

Caratteristiche - Modelli Specifications - Models		BSL 125	
Diametro tavola Table diameter	mm.	125	
Altezza punta Center height	mm.	127	
Inclinazione Tilt range		$-10^{\circ} \div 92^{\circ}$	
Asse Axis		Girevole Rotary	Inclinabile Tilting
Rapporto vite/corona Worm screw/wheel ratio		1/180	1/180
Velocità massima di rotazione Max rotation speed	Rpm	16,6	16,6
Precisione di posizionamento con encoder diretto Indexing accuracy with direct encoder	sec.	$\pm 5$	$\pm 5$
Incremento minimo Minimum increase		0,001°	
Peso max ammesso 0° Max allowable load 0°	 Kg.	40	
Peso netto tavola Table net weight	Kg.	55	



Tavole roto-basculanti per macchine EDM  
 CNC rotary tilting tables for EDM machines



BSL 125

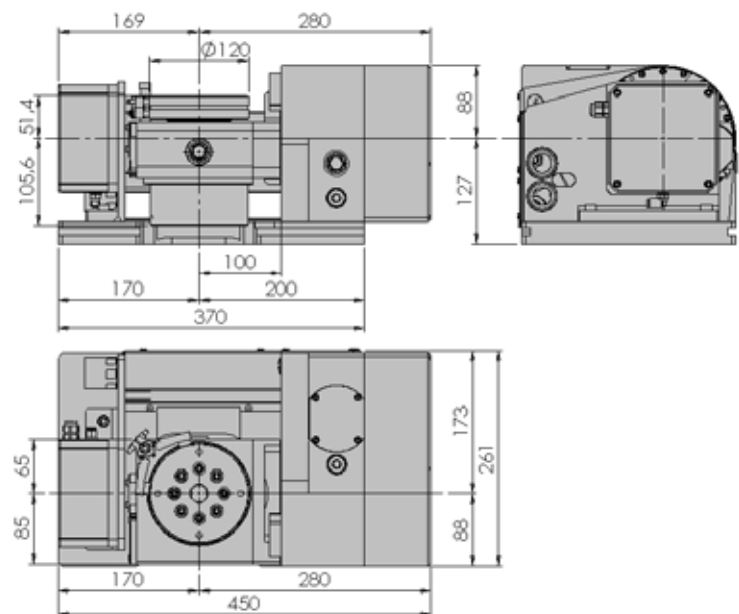

## Tavole girevoli cnc Cnc Rotary tables

Posizionamento orizzontale sulla tavola della macchina  
Trasmissione meccanica - Bloccaggio idraulico

Horizontal positioning on machine table  
Mechanical transmission - Hydraulic clamping



Caratteristiche - Modelli Specifications - Models		TDE-M 500	TDE-M 600	TRB-M 550
Diámetro tavola Table diameter	mm.	510	610	550
Larghezza cave a T Table T-slots width	mm.	16	18	18
Capacità di bloccaggio (ldr. 40 Bar) Clamp torque (hydraulic at 40 Bar)	Nm.	1500	3300	3600
Grandezza motore (pagina 43) Servo motor size (page 43)		4	5	5
Rapporto di riduzione Speed reduction ratio		1/90	1/90	1/154
Velocità massima di rotazione Max rotation speed	Rpm	33,3	33,3	12,8
Precisione di posizionamento Indexing accuracy	sec.	±10	±10	±10
Peso max ammesso orizz. Max allowable load horiz.	Kg	2000	3000	3000
Spinta max ammessa orizz. Max allowable thrust horiz.	N	40000	65000	65000
Coppia di lavoro Working torque	Nm	525	1004	1700
Peso netto tavola Table net weight	Kg.	250	420	355

Le tavole serie TRB-M sono progettate per essere completamente integrate all'interno del banco della macchina. Questa soluzione consente di avere sempre completamente libera la superficie della tavola della fresatrice.

Le tavole serie TRB-M e TDE-M possono essere fornite con:

- Encoder di posizionamento in asse con precisione  $\pm 5''$  o  $\pm 2,5''$ . Vedi pag. 41.
- Personalizzazione del piano tavola con scanalature a T diverse dallo standard, piattello liscio o fori filettati.
- Verniciatura con RAL specifico
- Carter motore modificato

The TRB-M table series are designed for complete integration to the machine tool bench. This solution allows full use of milling table surface without restriction.

The TRB-M e TDE-M table series can be equipped with:

- Positioning encoder mounted in axis with  $\pm 5''$  or  $\pm 2,5''$  accuracy. See page 41.
- Personalization of the table surface with various T-slots, smooth plate, or threaded holes.
- Painted to specific RAL colour
- Modified motor cover

### TRB-M 550

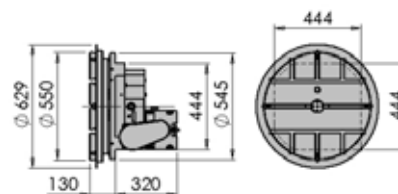

### TDE-M 500

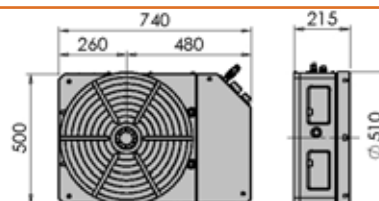
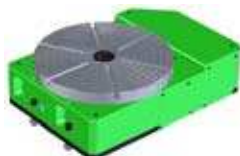

### TDE-M 600

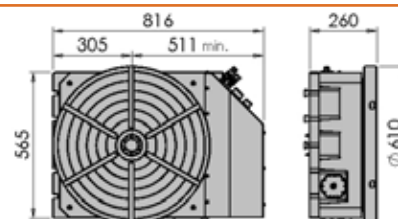

**Tavole roto-basculanti cnc**  
**CNC Tilting rotary tables**

Specifiche per macchine a 5 assi  
Trasmissione meccanica - Bloccaggio idraulico

Designed and made for 5 axis machines  
Mechanical transmission - Hydraulic clamping

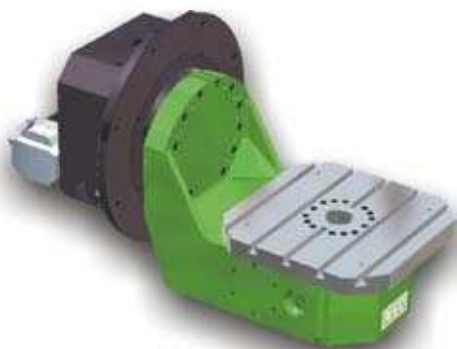

Caratteristiche Specifications		BRS MM 500
Dimensioni tavola Table Dimensions	mm.	500 x 500
Diametro massimo pezzo Max diameter of workpiece	mm.	600
Larghezza cave a T Table T-slots width	mm.	14
Inclinazione Tilt range		± 100°
Peso max ammesso Max allowable load	Kg.	250
Peso netto tavola Table net weight	Kg.	750

Caratteristiche Specifications	Asse Axis	Girevole Rotary	Inclinabile Tilting
Sistema di bloccaggio Clamp system		Idraulico Hydraulic	Idraulico Hydraulic
Capacità di bloccaggio a 50 bar Clamp torque at 50 Bar	Nm.	2.000	3.800
Grandezza motore (pagina 43) Servo motor size (page 43)		4	5
Velocità massima di rotazione Max rotation speed	Rpm	25	25
Precisione di posizionamento* Indexing accuracy*	sec.	± 15	± 30
Coppia di lavoro Working torque	Nm	613	1974

\*Le tavole serie BRS-MM sono predisposte per l'installazione di encoder ad altissima risoluzione (fino a ±2,5") su entrambe gli assi. Possono inoltre essere dotate di distributore idraulico/pneumatico per la gestione di eventuali attrezzature di presa installate sul piano tavola.

\*The BRS-MM table series are prepared for installation of high resolution encoders (up to ±2,5") on both axis. They can also be equipped with hydraulic/pneumatic distributor for the control of any workholding equipment installed on the table surface.

**BRS-MM 500**

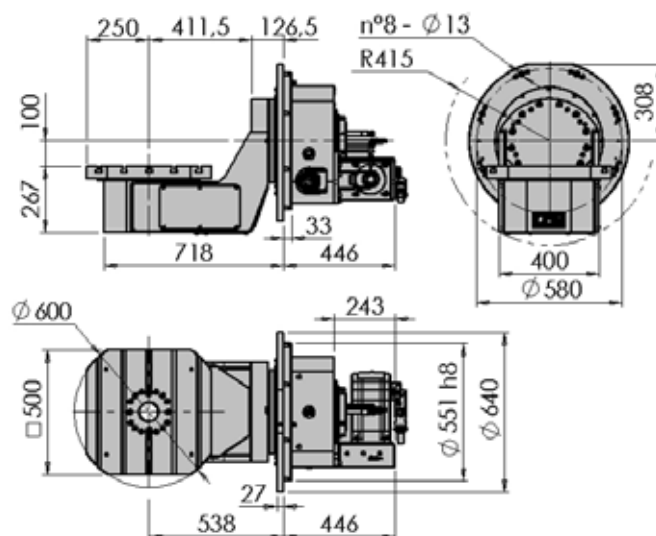

## Tavole roto-basculanti cnc CNC Tilting rotary tables

Specifiche per macchine a 5 assi  
Trasmissione meccanica - Bloccaggio idraulico

Designed and made for 5 axis machines  
Mechanical transmission - Hydraulic clamping



Caratteristiche - Modelli Specifications - Models		BRC-M 200 (250)	BRC-M 350 (400)	BRC-M 500	BRC-M 600				
Diametro tavola Table diameter	mm.	200 (Opt. 250)	350 (Opt 400)	500	600				
Diametro massimo pezzo Max diameter of workpiece	mm.	320	560	640	700				
Larghezza cave a T Table T-slots width	mm.	10	14	18	18				
Inclinazione Tilt range		-30° ÷ 110°	-30° ÷ 110°	-30° ÷ 110°	-30° ÷ 110°				
Asse Axis		Girevole Rotary	Inclinabile Tilting	Girevole Rotary	Inclinabile Tilting	Girevole Rotary	Inclinabile Tilting	Girevole Rotary	Inclinabile Tilting
Sistema di bloccaggio Clamp system		Pneumatico Pneumatic	Pneumatico Pneumatic	Pneumatico Pneumatic	Pneumatico Pneumatic	Idraulico Hydraulic	Idraulico Hydraulic	Idraulico Hydraulic	Idraulico Hydraulic
Capacità di bloccaggio (press. in ingresso) Clamp torque (entry pressure)	Nm.	400 (6 Bar)	1000 (6 Bar)	1000 (6 Bar)	1600 (6 Bar)	1200 (60 Bar)	2800 (60 Bar)	2200 (40 Bar)	3000 (40 Bar)
Rapporto asse/motore Axis/motor ratio		1/120	1/120	1/120	1/120	1/120	1/180	1/180	1/180
Grandezza motore (pagina 43) Servo motor size (page 43)		3	3	4	4	4	5	4	6
Velocità massima di rotazione Max rotation speed	Rpm	25	25	25	25	25	16,6	16,6	16,6
Precisione di posizionamento* Indexing accuracy*	sec.	±10	±30	±10	±30	±10	±30	±10	±30
Coppia di lavoro Working torque	Nm	200	200	670	670	670	1130	1130	2370
Peso max ammesso 0° Max allowable load 0°	Kg.	150	150	300	300	500	500	700	700
Peso max ammesso 90° Max allowable load 90°	Kg.	125	125	250	250	400	400	550	550
Spinta max ammessa 0° Max allowable thrust 0°	N.	10000	10000	18000	18000	22000	22000	30000	30000
Spinta max ammessa 90° Max allowable thrust 90°	FxL Nm	800	800	1400	1400	1800	1800	2700	2700
Peso netto tavola Table net weight	Kg.	160	160	400	400	550	550	750	750

\*Le tavole serie BRC-M sono predisposte per l'installazione di encoder ad altissima risoluzione (fino a ±2,5") su entrambe gli assi. Possono inoltre essere dotate di distributore idraulico/pneumatico per la gestione di eventuali attrezzature di presa installate sul piano tavola.

\*The BRC-M table series are prepared for installation of high resolution encoders (up to ±2,5") on both axis. They can also be equipped with hydraulic/pneumatic distributor for the control of any workholding equipment installed on the table surface.

**BRC-M 200 (250)**

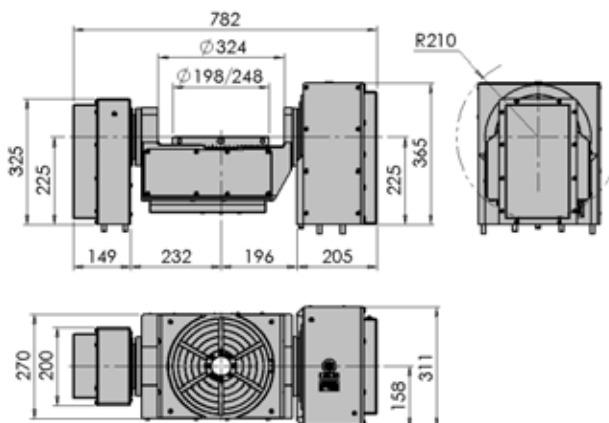
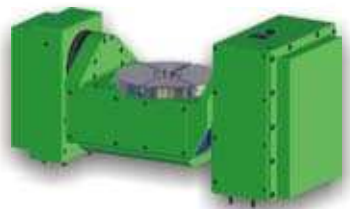

**BRC-M 350 (400)**

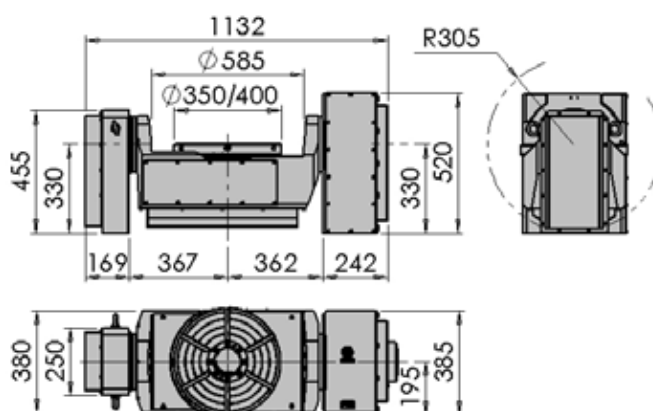
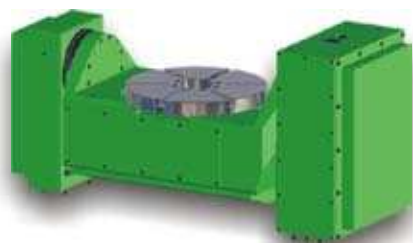

**BRC-M 500**

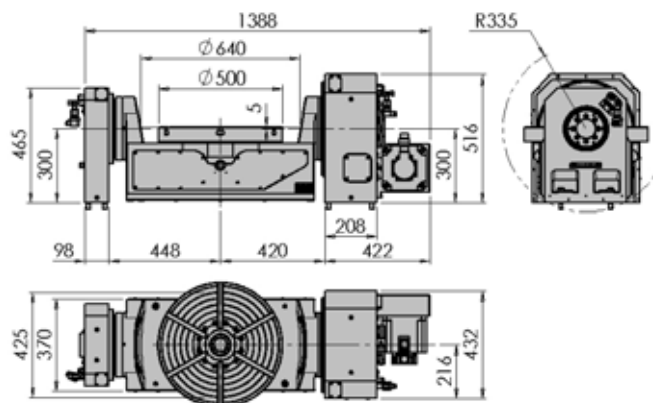
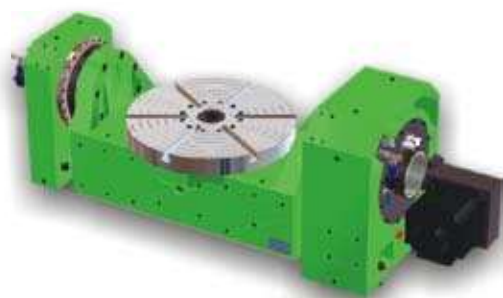

**BRC-M 600**

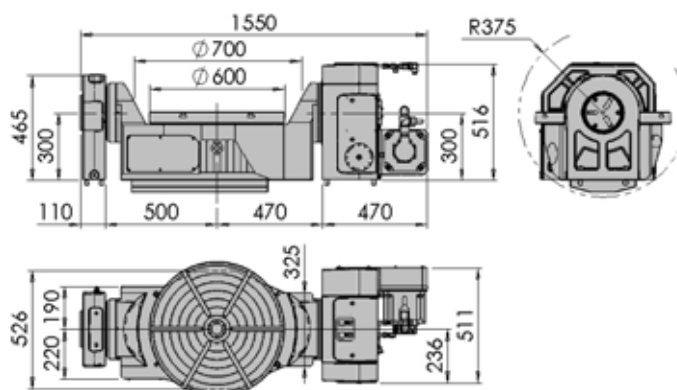

## Tavole girevoli cnc con motore coppia Cnc Rotary tables with torque motor

Motore coppia  
Bloccaggio idraulico

Torque motor  
Hydraulic clamping







Le tavole serie TDE- T possono essere fornite con:

- Personalizzazione del piano tavola con scanalature a T diverse dallo standard, piattello liscio o fori filettati.
- Verniciatura con RAL specifico

The TDE-T table series can be supplied with:

- Personalization of the table surface with various T-slots, smooth plate, or threaded holes.
- Painted to specific RAL colour

Caratteristiche - Modelli Specifications - Models		TDE-TV 270	TDE-TV 400	TDE-TH 450	TDE-TH 600	TDE-TH 800 (1000)
Diámetro tavola Table diameter	mm.	270	400	450	610	800 (Opt.1000)
Diámetro foro centrale Center bore	mm.	75 X L=186	105 X L=201	50 X L=30	50 X L=30	60 X L=30
Altezza punte Center height	mm.	250	350	////	////	////
Larghezza cave a T Table T-slots width	mm.	12	14	14	18	22
Sistema di bloccaggio Clamp system		Idraulico Hydraulic	Idraulico Hydraulic	Idraulico Hydraulic	Idraulico Hydraulic	Idraulico Hydraulic
Capacità di bloccaggio Clamp torque (entry pressure)	Nm.	855 (50 Bar)	1960 (50 Bar)	1800 (50 Bar)	3000 (40 Bar)	5000 (40 Bar)
Coppia nominale (S1) Continuous torque (S1)	Nm.	345	540	400	880	1240
Coppia massima (S6) Peak torque (S6)	Nm.	580	990	710	1660	2330
Velocità massima di rotazione Max rotation speed	Rpm	150	120	130	100	90
Precisione di posizionamento Indexing accuracy	sec.	±5	±5	±5	±5	±5
Peso max ammesso Max allowable load	 Kgf	400	1300	////	////	////
Spinta max ammessa Max allowable thrust	 F x L Nm	1900	2500	3000	4900	6000
Peso max ammesso orizzontale Max allowable load horizontal	 Kgf	////	////	1300	2000	2500
Spinta max ammessa orizzontale Max allowable thrust horizontal	 N	////	////	30000	65000	80000
Peso netto tavola Table net weight	Kg.	200	315	270	620	1050

Motore coppia  
Torque motor



Tavole girevoli cnc con motore coppia  
Cnc Rotary tables with torque motor

Motore coppia  
Bloccaggio idraulico

Torque motor  
Hydraulic clamping

**TDE-TV 270**

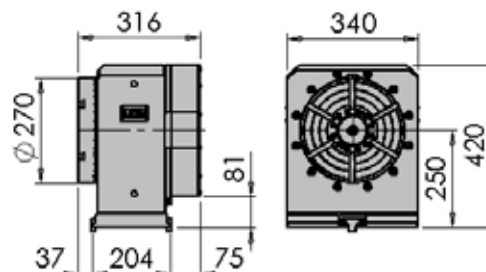

**TDE-TV 400**

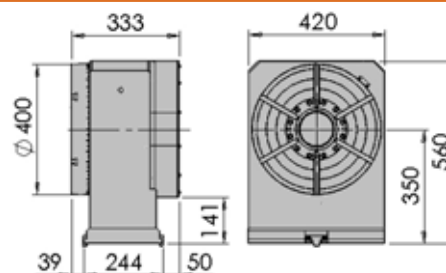

**TDE-TH 450**

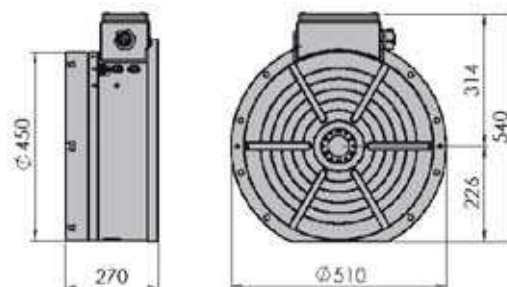

**TDE-TH 600**

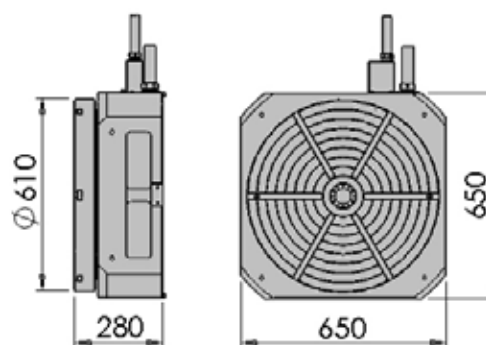
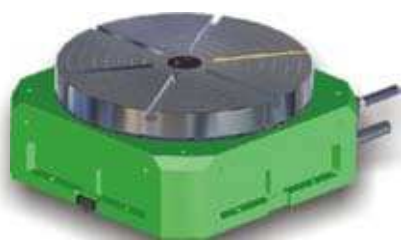

**TDE-TH 800 (1000)**

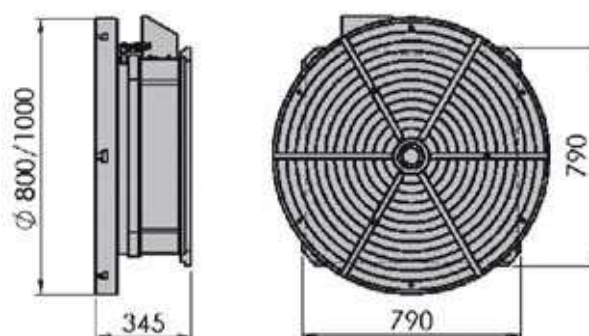
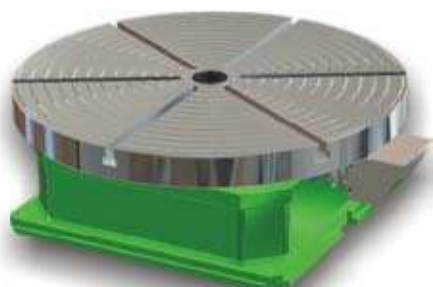

## Tavole girevoli cnc con motore coppia Cnc Rotary tables with torque motor

Posizionamento orizzontale nella tavola della macchina  
Motore coppia - Bloccaggio idraulico

Horizontal positioning inside the machine table  
Torque motor - Hydraulic clamping



Le tavole serie TRB-T sono progettate per essere completamente integrate all'interno del banco della macchina. Questa soluzione consente di avere sempre completamente libera la superficie della tavola della fresatrice.



Le tavole della serie TRB-T possono essere fornite con:

- Personalizzazione del piano tavola con scanalature a T diverse dallo standard, piattello liscio o con fori filettati.
- Verniciatura con RAL specifico

The TRB-T table series are designed for complete integration to the machine tool bench. This solution allows full use of milling table surface without restriction.

TRB-T table series can be supplied with:

- Personalization of the table surface with various T-slots, smooth plate, or threaded holes.
- Painted to specific RAL colour

Caratteristiche - Modelli Specifications - Models		TRB-T 400	TRB-T 600	TRB-T 800
Diametro tavola Table diameter	mm.	400	610	800
Larghezza cave a T Table T-slots width	mm.	14	18	18
Sistema di bloccaggio Clamp system		Idraulico Hydraulic	Idraulico Hydraulic	Idraulico Hydraulic
Capacità di bloccaggio (pressione in ingresso) Clamp torque (entry pressure)	Nm.	1150 (60 Bar)	3000 (40 Bar)	5900 (40 Bar)
Coppia nominale (S1) Continuous torque (S1)	Nm.	400	910	1280
Coppia massima (S6) Peak torque (S6)	Nm.	710	1660	2330
Velocità massima di rotazione Max rotation speed	Rpm	130	100	90
Precisione di posizionamento Indexing accuracy	sec.	±5	±5	±5
Peso max ammesso orizzontale Max allowable load horizontal	 Kg	1300	2000	2500
Spinta max ammessa orizzontale Max allowable thrust horizontal	 N	30000	65000	80000
Peso netto tavola Table net weight	Kg.	230	430	680



Motore coppia  
Torque motor



Tavole girevoli cnc con motore coppia  
Cnc Rotary tables with torque motor

Posizionamento orizzontale nella tavola della macchina  
Motore coppia - Bloccaggio idraulico

Horizontal positioning inside the machine table  
Torque motor - Hydraulic clamping

TRB-T 400

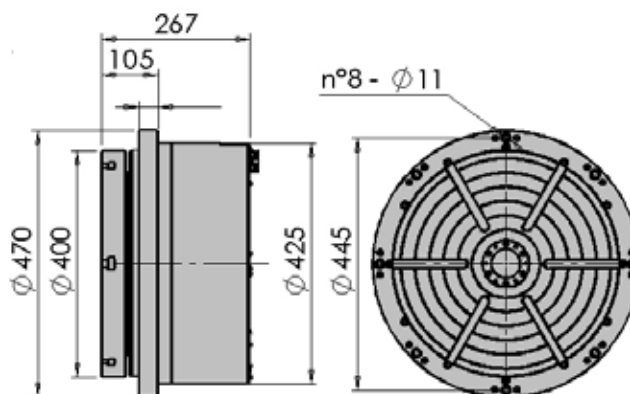
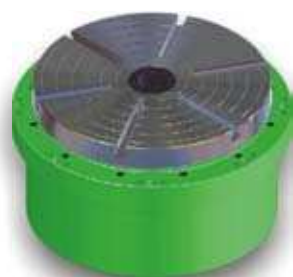

TRB-T 600

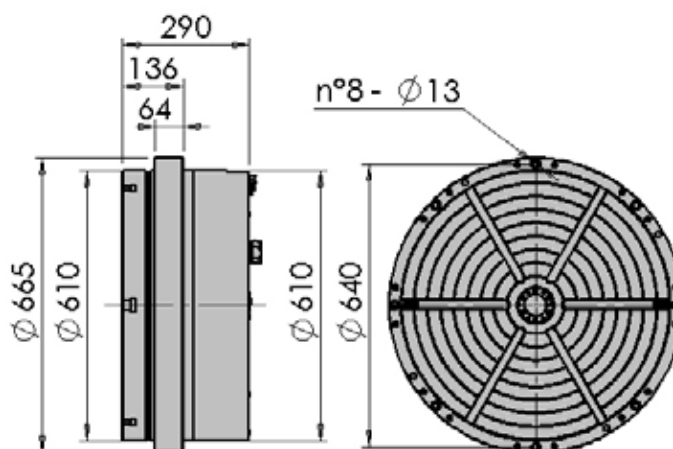

TRB-T 800

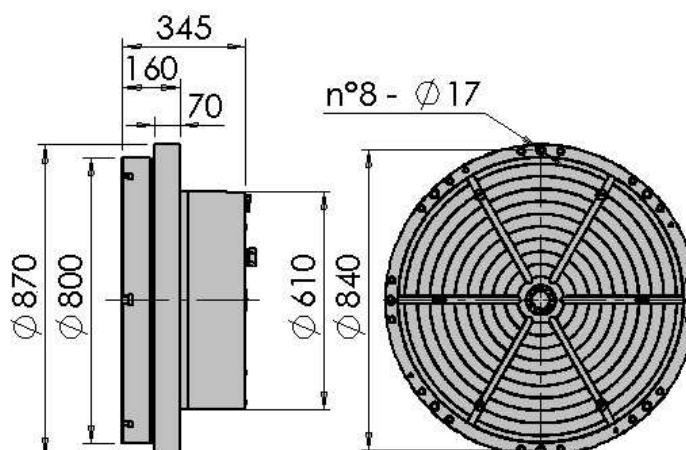
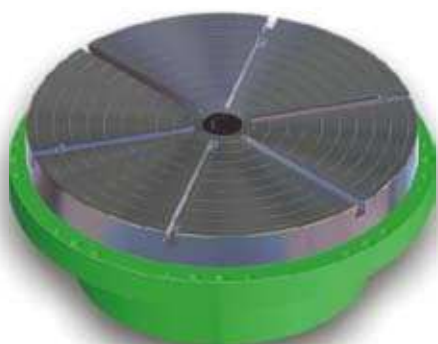

# BRC-TM / BRC-TT





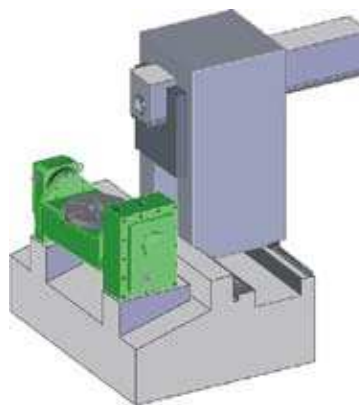

## Tavole roto-basculanti torque Torque tilting rotary table

Specifiche per macchine a 5 assi  
Motori coppia  
Bloccaggio idraulico

Designed and made for 5 axis machines  
Torque motor  
Hydraulic clamping



Caratteristiche - Modelli Specifications - Models		BRC-TM 400		BRC-TT 600	
Diámetro tavola Table diameter	mm.	400		600	
Diámetro massimo pezzo Max diameter of workpiece	mm.	520		860	
Larghezza cave a T Table T-slot width	mm.	14		14	
Inclinazione Tilt range		-110° ÷ 110°		-120° ÷ 120°	
Asse Axis		Girevole Rotary	Inclinabile Tilting	Girevole Rotary	Inclinabile Tilting
Sistema di bloccaggio Clamp system		Idraulico Hydraulic	Idraulico Hydraulic	Idraulico Hydraulic	Idraulico Hydraulic
Capacità di bloccaggio Clamp torque	Nm.	1200 (60 Bar)	3100 (60 Bar)	2500 (40 Bar)	4500 (40 Bar)
Rapporto asse/motore Axis/motor ratio		1/1	1/180	1/1	1/1
Grandezza motore (pagina 43) Servo motor size (page 43)		Coppia Torque	5	Coppia Torque	Coppia Torque
Velocità massima di rotazione Max rotation speed	Rpm	90	16,6	120	60
Precisione di posizionamento* Indexing accuracy	sec.	± 5	± 25	± 5	± 5
Coppia di lavoro Working torque	 Nm	536 (S1)	1500	620 (S1)	1600 (S1)
Peso max ammesso 0° Allowable work weight 0°	 Kg.	400		500	
Spinta max ammessa 0° Allowable load 0°	 N.	15000		22000	
Spinta max ammessa 90° Allowable load 90°	 FxL Nm	3100		4500	
Peso netto tavola Table net weight	Kg.	550		1400	

\*Le tavole serie BRC-TM / BRC-TT sono predisposte per l'installazione di encoder ad alta risoluzione (fino a ±2,5") su entrambe gli assi. Possono inoltre essere dotate di distributore idraulico/pneumatico per la gestione di eventuali attrezzature di presa installate sul piano tavola.

\*The BRC-TM / BRC-TT table series are prepared for installation of high resolution encoders (up to ±2,5") on both axis. They can also be equipped with hydraulic/pneumatic distributor for the control of any workholding equipment installed on the table surface.

Tavole roto-basculanti torque  
Torque tilting rotary table

Motore coppia  
Torque motor



Specifiche per a 5 assi  
Motori coppia  
Bloccaggio idraulico

Designed and made for 5 axis machines  
Torque motors  
Hydraulic clamping

**BRC-TM 400**

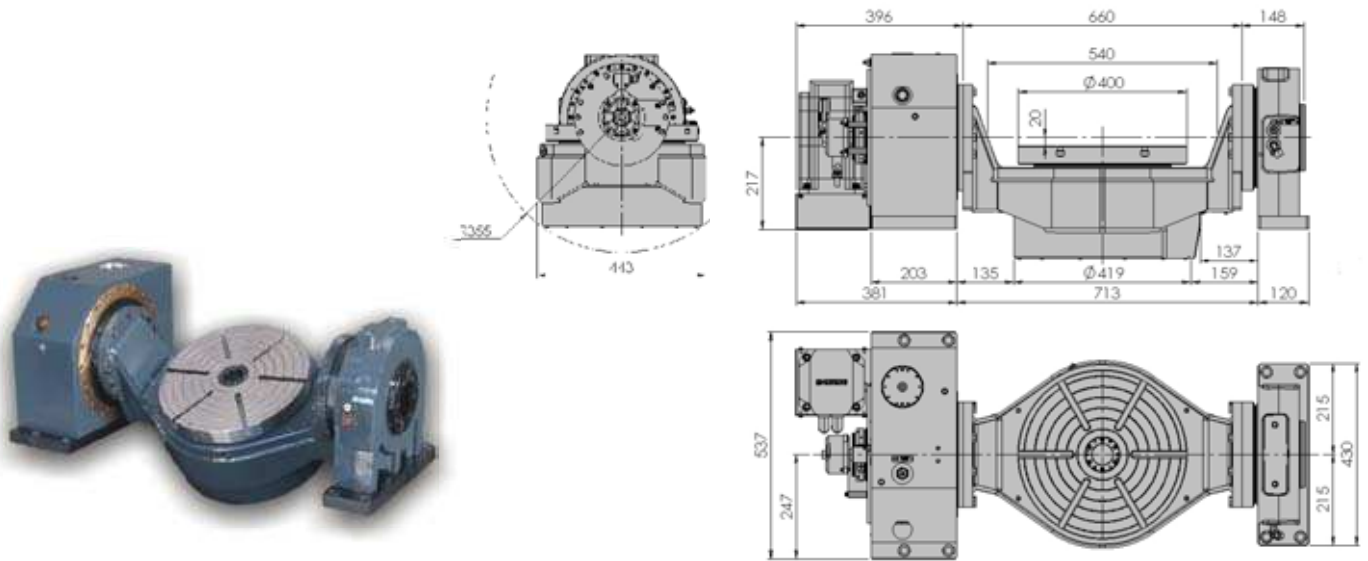

**BRC-TT 600**

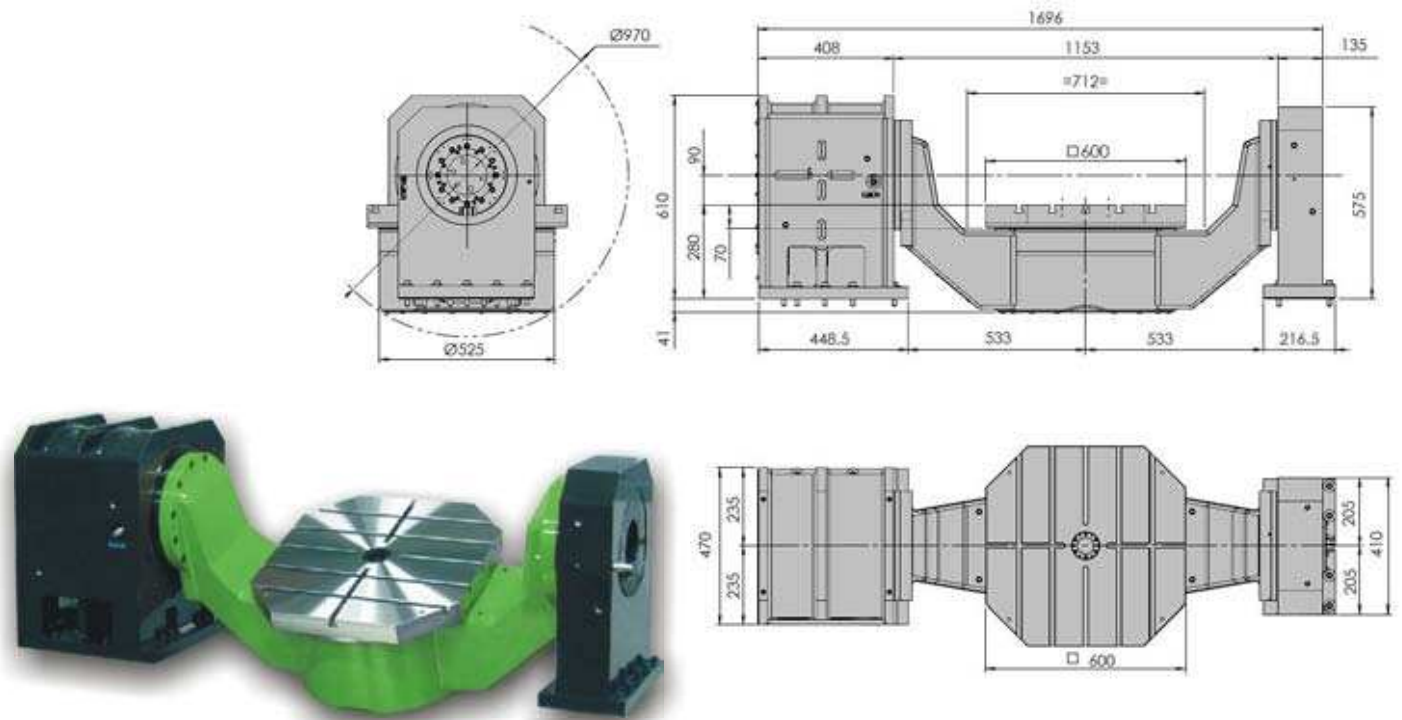

## Teste di fresatura tiltanti

### Tilting heads for milling

Trasmissione meccanica

Mechanical transmission

Bloccaggio idraulico

Hydraulic clamping

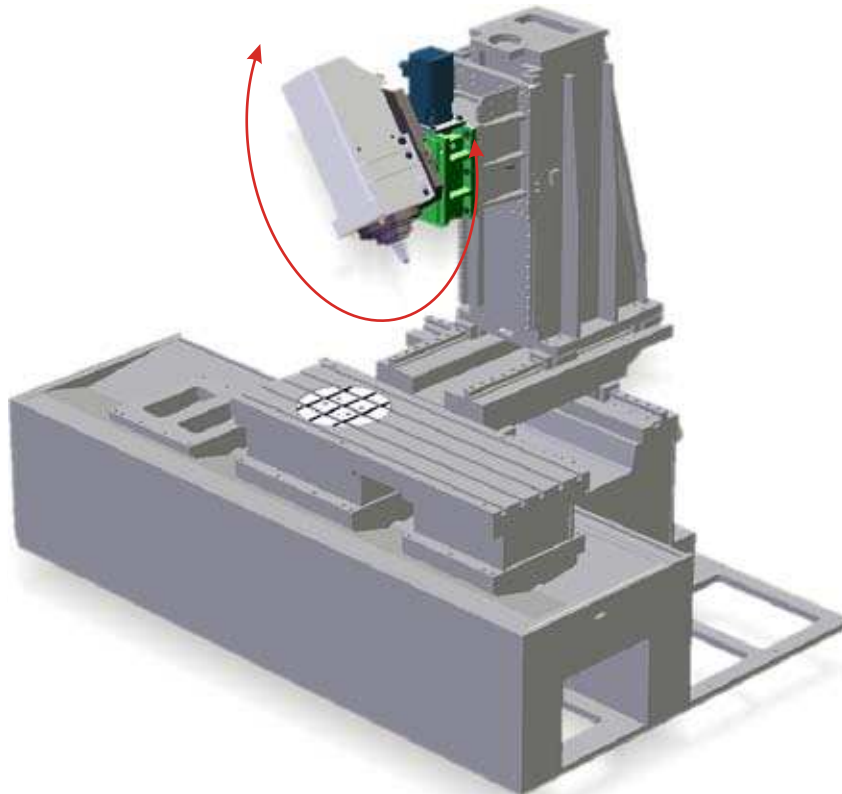

Le teste serie MD sono la soluzione ideale per i costruttori che vogliono realizzare fresatrici con il 4° asse posto dietro all'elettromandrino. I gruppi MD-M consentono di inclinare, in continuo, l'asse mandrino da +100° a -100°. Sono dotati di sistemi di trasmissione meccanici, di bloccaggi idraulici e di encoder di posizionamento ad alta risoluzione montati diretti in asse. Per poter soddisfare le specifiche esigenze di applicazione, i modelli della serie MD sono 5 e possono essere forniti in alcune differenti versioni. La scelta della miglior configurazione può essere effettuata in alcuni semplici passaggi:

1. Scelta della grandezza in funzione delle dimensioni e potenza dell'elettromandrino previsto.
2. Al fine di offrire al cliente la possibilità di utilizzare elettromandri non costruiti da LCM, i gruppi MD possono essere predisposti per il fissaggio di elettromandri quadri e con specifici alloggiamenti per mandrini a cartuccia.
3. In funzione della tipologia di macchina e degli spazi a disposizione, scegliere la migliore posizione del motore e verificare la necessità di un distributore rotante integrato utile al contenimento degli ingombri totali della testa.

The MD series head represents the best solution for makers producing 5 axis machines who require the 4th axis behind the spindle. The MD-M units allow the spindle axis to be tilted with continuous motion from +100° to -100°. They have mechanical transmission system, hydraulic clamping and high resolution encoder mounted in axis.

To meet customer demands, 5 versions are available in various configurations.

Selection of the head is determined by some basic requirements:

1. Choice of size dependant on required spindle dimensions and capacity.
2. To provide greater flexibility, MD units can be prepared for square spindles not manufactured by LCM, or, with a housing designed for cartridge spindles.
3. Dependant on machine construction and space limitations, different motor locations and a choice of flexible cable system or rotary union is possible.

Teste di fresatura tiltanti  
Tilting heads for milling

Scelta della testa in funzione della geometria della macchina  
Choice of head depending on machine geometry

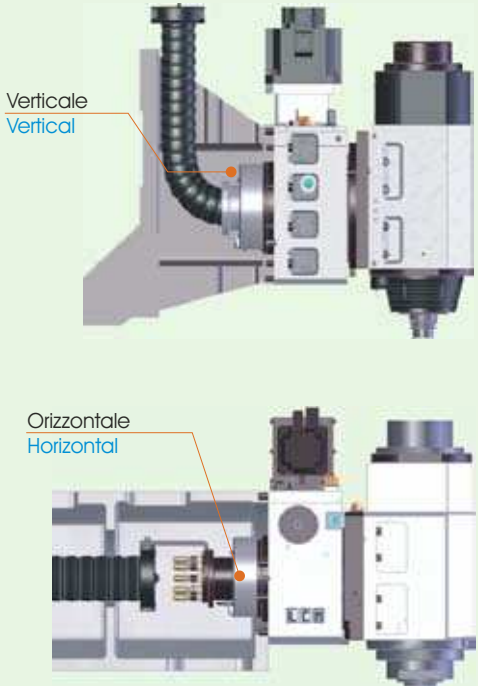
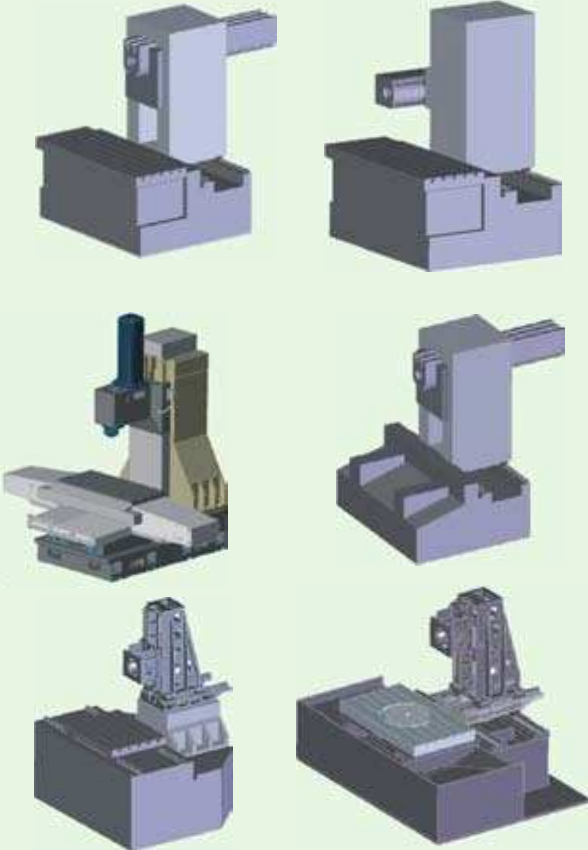
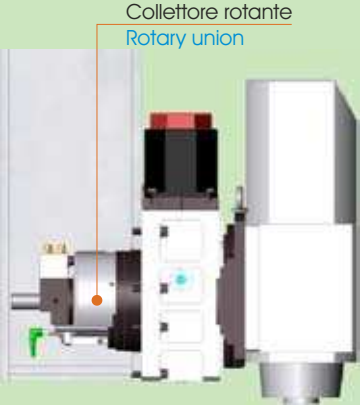
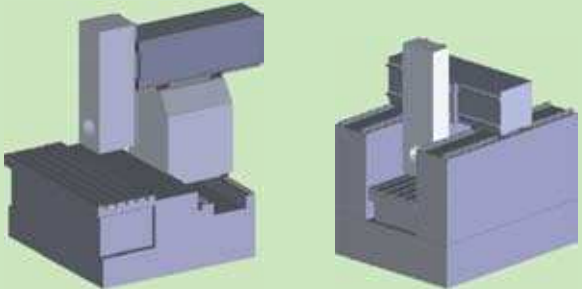



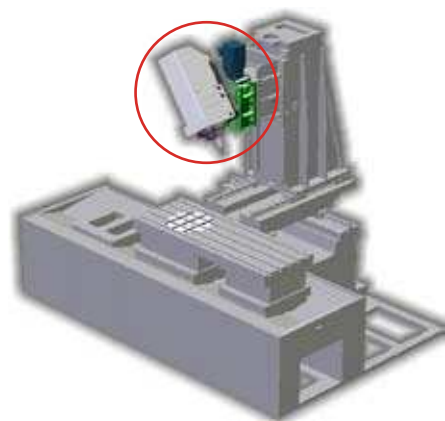

Tipo di testa Type of head	Geometria macchina Machine geometry
<p>Gruppo completo di catenaria che consente la rotazione dei cavi e dei tubi di alimentazione. E' la versione standard.</p> <p>Units complete with robotic flexible cable chain. Fitted as standard allowing free rotation of cables and feed pipes.</p>  <p>Verticale Vertical</p> <p>Orizzontale Horizontal</p> <p>I</p>	
<p>Gruppo completo di distributore rotante fino a 11 canali. Versione da utilizzare nei casi in cui la zona dedicata all'alloggiamento della testa ha una profondità limitata.</p> <p>Unit complete with up to 11 utilities rotary union. This version to be adopted in cases of limited installation depth</p>  <p>Collettore rotante Rotary union</p> <p>C</p>	

## Teste di fresatura tiltanti Tilting heads for milling

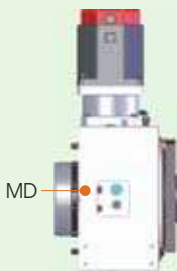
Trasmissione meccanica  
Mechanical transmission  
Bloccaggio idraulico  
Hydraulic clamping

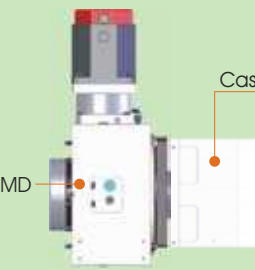

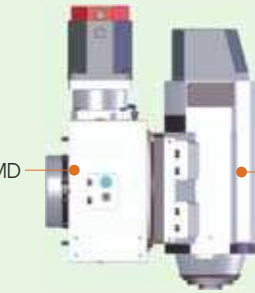
## Scelta della configurazione frontale Choice of spindle configuration

Caratteristiche Specifications	Tipo di testa Type of head	
<p>MD predisposto per elettromandrino quadro MD prepared for square electrospindle</p>	 <p>MD</p>	 <p>S</p>
<p>MD completo di case adatto al fissaggio di elettromandrino cilindrico a cartuccia MD complete of case suitable for the fixing of cartridge electrospindle</p>	 <p>MD</p> <p>Case</p>	 <p>C</p>
<p>MD completo di elettromandrino L.C.M. MD complete with L.C.M. electrospindle</p>	 <p>MD</p>	 <p>Elettromandrino L.C.M. L.C.M. Electrospindle</p> <p>E</p>

Scelta della posizione del motore  
Choice of the motor position

Caratteristiche Specifications	Tipo di testa Type of head		
<p>Trasmissione motore diretta verticale Vertical motor direct transmission</p>	 <p style="text-align: right;">A</p>		
<p>Trasmissione motore indiretta verticale Vertical motor indirect transmission</p>	 <p style="text-align: right;">B</p>		
<p>Trasmissione motore indiretta orizzontale Horizontal motor indirect transmission</p>	 <p style="text-align: right;">C</p>		
<p>Trasmissione motore indiretta esterna External motor indirect transmission</p>	 <p style="text-align: right;">D</p>		

I nostri ingegneri sono a disposizione per supportarVi nella scelta e nell'eventuale personalizzazione dei gruppi.  
Our engineers are at your disposal to support you in the choice and personalization of the units, if necessary.

## Teste di fresatura tiltanti Tilting heads for milling

Trasmissione meccanica  
Mechanical transmission  
Bloccaggio idraulico  
Hydraulic clamping



Caratteristiche - Modelli Specifications - Models		MD 90	MD 125	MD 160	MD 200
Campo di lavoro Tilt range		± 100°	± 100°	± 100°	± 100°
Velocità massima di inclinazione testa Maximum head rotation speed	RPM	50	50	33	33
Forza di bloccaggio (Pressione in ingresso) Clamping torque (Entry oil pressure)	Nm	1100 (100 Bar)	1360 (50 Bar)	2000 (50 Bar)	7300 (60 Bar)
Spinta in lavoro Working torque	Nm	168	504	1386	1386
Precisione di posizionamento Indexing accuracy	sec.	± 7	± 7	± 7	± 7
Ripetibilità Repeatability	sec.	± 3	± 3	± 3	± 3
Grandezza motore (pagina 43) Servo motor size (page 43)		3	5	6	6
Diametro massimo elettromandrino Maximum diameter of electrospindle	mm.	120	200	250	300
Peso netto testa (senza elettromandrino) Head net weight (without electrospindle)	Kg.	80	150	220	415

## MD 90

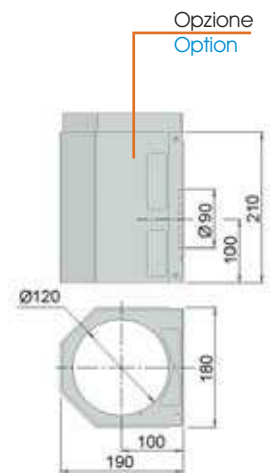
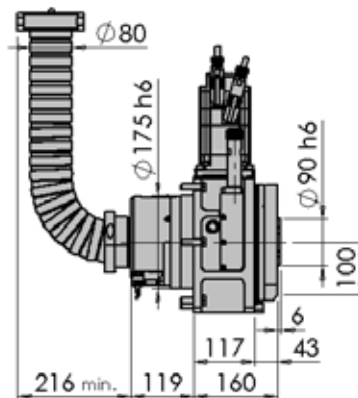
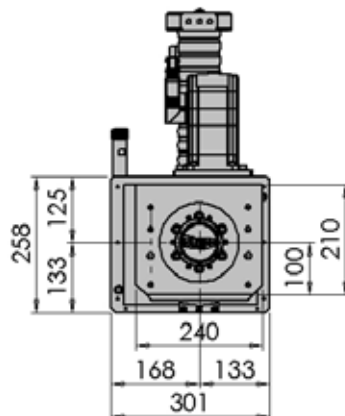



**MD 125**

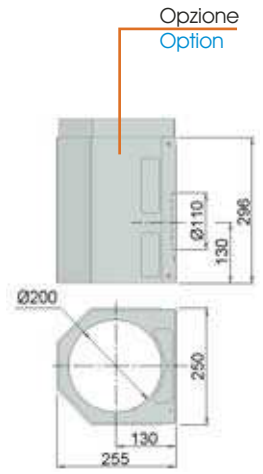
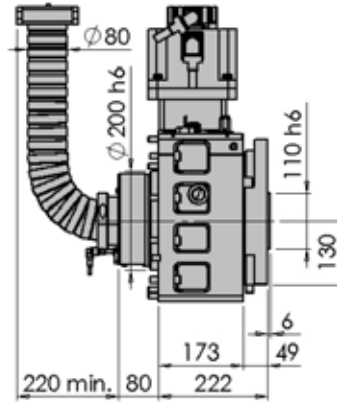
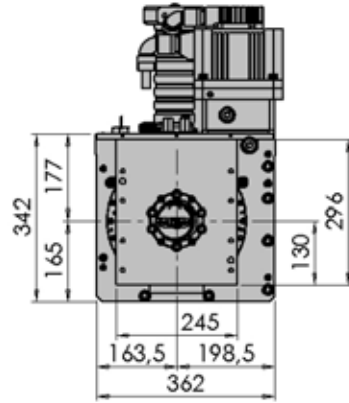

Opzione  
Option

**MD 160**

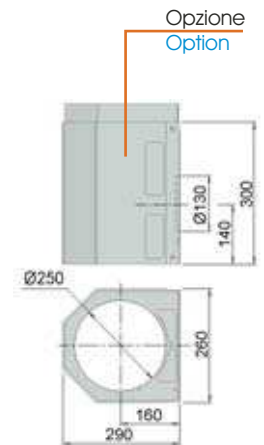
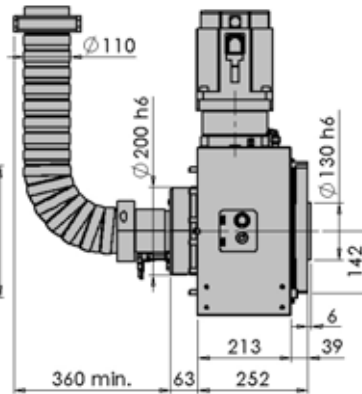
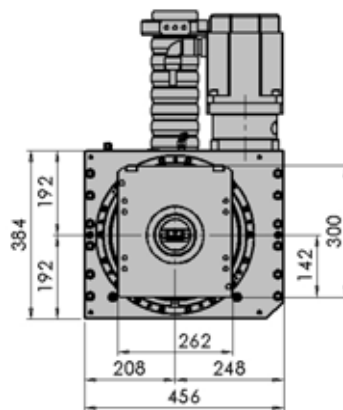

Opzione  
Option

**MD 200**

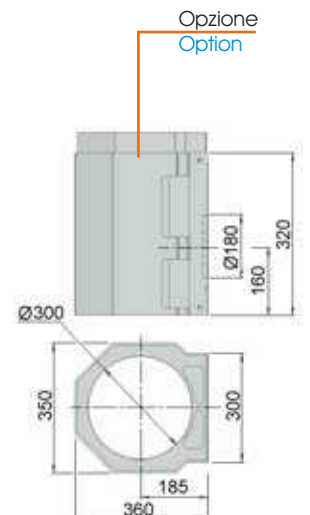
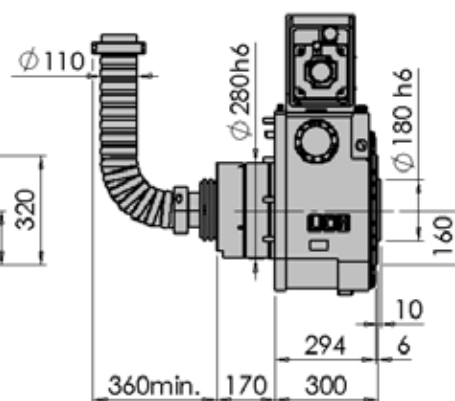
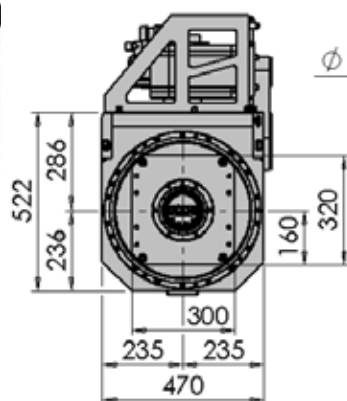

Opzione  
Option

## Elettromandrino per teste MD

### Electrospindle for MD heads



Gli elettromandrini realizzati da L.C.M sono studiati per essere utilizzati con le teste della linea MD. Le dimensioni e tutti i componenti sono stati progettati per funzionare correttamente sia in posizione verticale che orizzontale. Il sistema di fissaggio e connessione consente di evitare l'utilizzo di supporti ed interfacce aggiuntive. La struttura realizzata in lega garantisce un'ottimo rapporto peso rigidità. I cuscinetti ibridi ceramici utilizzati permettono velocità di rotazione molto elevate con il minimo riscaldamento. L'encoder diretto sull'asse di rotazione, consente l'operazione di maschiatura rigida e l'orientamento angolare dell'albero. Il raffreddamento motore è a liquido ed il sistema di sbloccaggio utensile è a funzionamento oleodinamico.

L.C.M electrospindles (built-in motors) are designed specifically for use with the MD series tilting head. The structure and all components have been designed to work reliably in both vertical and horizontal positions. The spindle mounting and utility connection system eliminates the need for additional housing and interface connections. Using the high strength alloy structure guarantees a good weight to rigidity ratio. Low temperature and minimal thermal expansion is assured with ceramic bearings and liquid cooling. A directly mounted encoder is fitted to allow rigid tapping and spindle orientation.. The motor cooling is by liquid and tool unclamp is hydraulic.

Modello Model	Attacco Taper	Potenza Power	Coppia S1 * Torque S1 *	Coppia S6 * Torque S6 *	Velocità Max Max speed		Predisposto per teste Suitable for heads
					Lubrification Lubrication		
					Aria-olio Air oil	Grasso Grease	
ELQ 160-14	HSK A50 ISO 30	14 kW	18 Nm	28 Nm	30.000	—	MD 90
					—	24.000	
					—	20.000	
ELQ 200-21	HSK 63 ISO 40	21 kW	67 Nm	103 Nm	24.000	—	MD 125
					—	18.000	
					20.000	—	
ELQ 240 - 24	HSK 63 ISO 40	24 kW	78 Nm	120 Nm	—	16.000	MD 125 MD 160
					—	12.000	
					18.000	—	
ELQ 250-33	HSK 63 ISO 40	33 kW	105 Nm	162 Nm	—	15.000	MD 160
					—	12.000	
					18.000	—	
ELQ 270-38	HSK 80 ISO 40	38 kW	166 Nm	234 Nm	18.000	—	MD 160 MD 200
					—	10.000	
					18.000	—	
ELQ 275-38	HSK A 100 ISO 50	38 kW	166 Nm	234 Nm	—	10.000	MD 160 MD 200
					—	8.000	
					—	—	

\* 3.000 RPM

Teste di fresatura tiltanti  
Tilting heads for milling

I tecnici del nostro reparto ricerca e sviluppo sono a disposizione dei costruttori per valutare e realizzare eventuali modifiche alle teste MD per integrarle al meglio alla struttura della propria macchina utensile.

Con oltre 10 anni di esperienza specifica nella produzione di teste tilting, i tecnici L.C.M. affiancano i clienti nella progettazione e nella realizzazione delle fresatrici a 5 assi.

Qui di seguito ci sono alcune immagini di teste MD prodotte negli anni.

Our technicians of R & D department are at the constructors' disposal to evaluate and make changes, if necessary, on MD heads, to be integrated to their machine tool structure, in the best way.

Thanks to more than 10 years specific experience in swivelling heads production, L.C.M. technicians assist the customers in designing and producing 5 axes milling machines.

In this page there are some pictures of MD heads constructed in the last years.

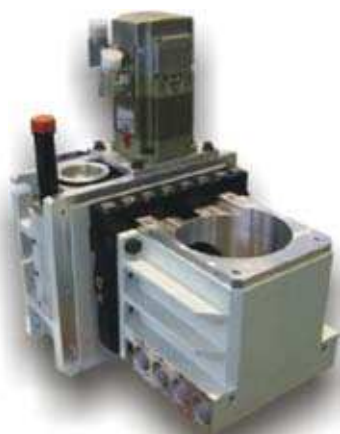

## Contropunte Tailstocks



### Contropunte manuali Manual tailstocks

#### CP3V - CP4V

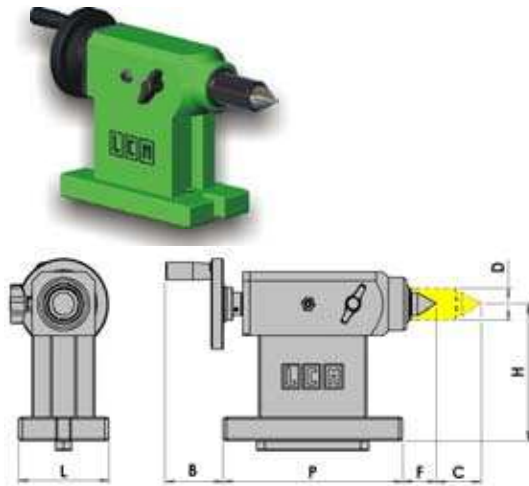

Modelli - Caratteristiche Models - Specifications	Cono morse Morse Taper	H	C	L	P	F	B	D
CP3V110	3	110	50	100	200	37	63	35
CP3V127	3	127	50	100	200	37	63	35
CP3V151	3	151	50	100	200	37	63	35
CP3V180	3	180	50	100	200	37	63	35
CP3V215	3	215	50	100	200	37	63	35
CP3V235	3	235	50	100	200	37	63	35
CP4V151	4	151	50	100	250	30	19	55
CP4V180	4	180	50	100	250	30	19	55
CP4V215	4	215	50	100	250	30	19	55
CP4V235	4	235	50	100	250	30	19	55

### Contropunte pneumatiche Pneumatic tailstocks

#### CP3P - CP4P

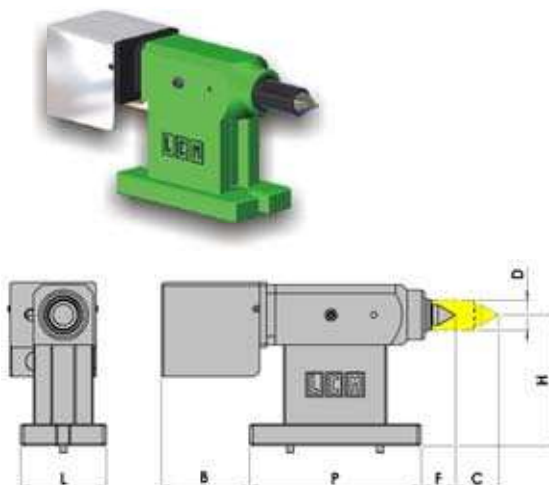

Modelli - Caratteristiche Models - Specifications	Cono morse Morse Taper	H	C	L	P	F	B	D
CP3P127	3	127	50	100	200	37	102	35
CP3P151	3	151	50	100	200	37	102	35
CP3P180	3	180	50	100	200	37	102	35
CP3P215	3	215	50	100	200	37	102	35
CP3P235	3	235	50	100	200	37	102	35
CP4P151	4	151	50	100	250	30	87	55
CP4P180	4	180	50	100	250	30	87	55
CP4P215	4	215	50	100	250	30	87	55
CP4P235	4	235	50	100	250	30	87	55

### Base reclinabile per contropunta Tilting base for tailstock

#### RB3 - RB4

Base utile ad inclinare la contropunta su un lato mantenendo l'allineamento con la tavola.  
Disponibile per tutte le versioni di contropunte.

Base useful to tilt the tailstock to one side maintaining the alignment with the table.  
Available for all versions of tailstocks.



**RB3** Base reclinabile per contropunte modello **CP3\_**  
**RB4** Base reclinabile per contropunte modello **CP4\_**

**RB3** Tilting base for tailstocks model **CP3\_**  
**RB4** Tilting base for tailstocks model **CP4\_**



Controsupporti  
Support spindles

Controsupporto con bloccaggio pneumatico  
Support spindle with pneumatic clamp

CSPS

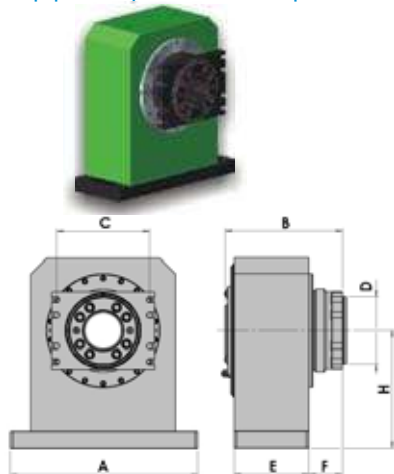

Modelli - Caratteristiche Models - Specifications	Coppia di bloccaggio (6 Bar) Clamp torque (6 Bar)	H	D	C	A	E	F	B
CSPS151	1000 Nm	151	130	180	330	145	65	227
CSPS180	1000 Nm	180	130	180	330	145	65	227
CSPS215	1000 Nm	215	130	180	330	145	65	227
CSPS250	1000 Nm	250	130	180	330	145	65	227

Controsupporto con bloccaggio idraulico  
Support spindle with hydraulic clamp

CSIT

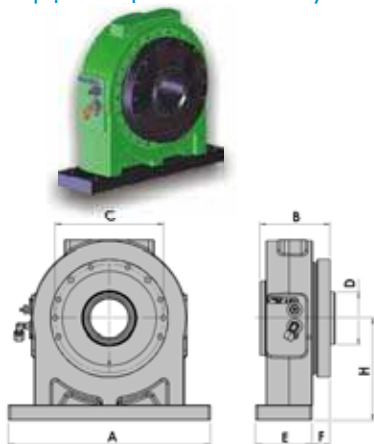

Modelli - Caratteristiche Models - Specifications	Coppia di bloccaggio (50 Bar) Clamp torque (50 Bar)	H	D	C	A	E	F	B
CSIT180	1300 Nm	180	110	230	430	120	38	149
CSIT215	1300 Nm	215	110	230	430	120	38	149
CSIT250	1300 Nm	250	110	230	430	120	38	149
CSIT300	1300 Nm	300	110	230	430	120	38	149

Controsupporto con bloccaggio idraulico  
Support spindle with hydraulic clamp

CSIS

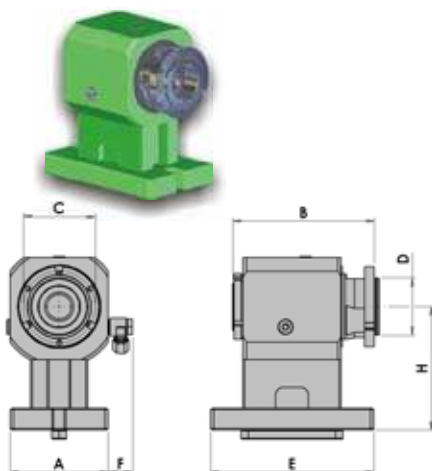

Modelli - Caratteristiche Models - Specifications	Coppia di bloccaggio (100 Bar) Clamp torque (100 Bar)	H	D	C	A	E	F	B
CSIS151	560 Nm	151	70	88	120	200	30	174
CSIS180	560 Nm	180	70	88	120	200	30	174
CSIS215	560 Nm	215	70	88	120	200	30	174
CSIS250	560 Nm	250	70	88	120	200	30	174

I controsupporti CSIS possono essere dotati di un distributore idraulico/pneumatico a 2 canali  
The CSIS support spindles can be equipped with a hydraulic/pneumatic distributor with 2 passages.

# Accessori - Sistemi di presa

## Accessories - Workholding

### Sistemi manuali

#### Manual systems

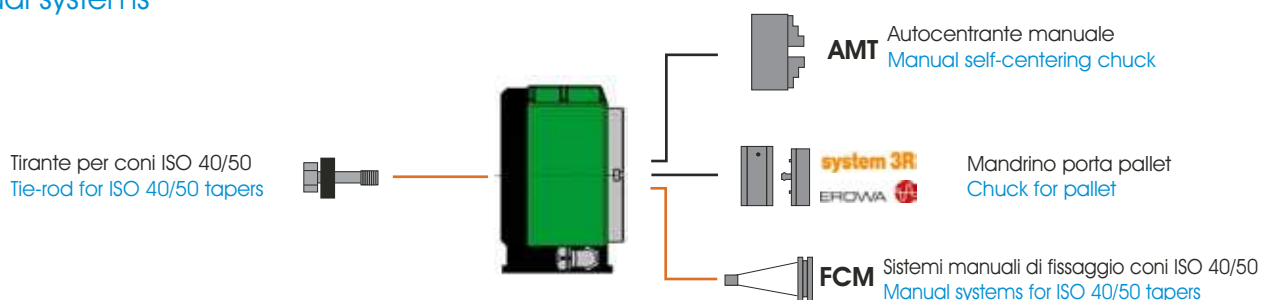

### Sistemi automatici

#### Automatic systems

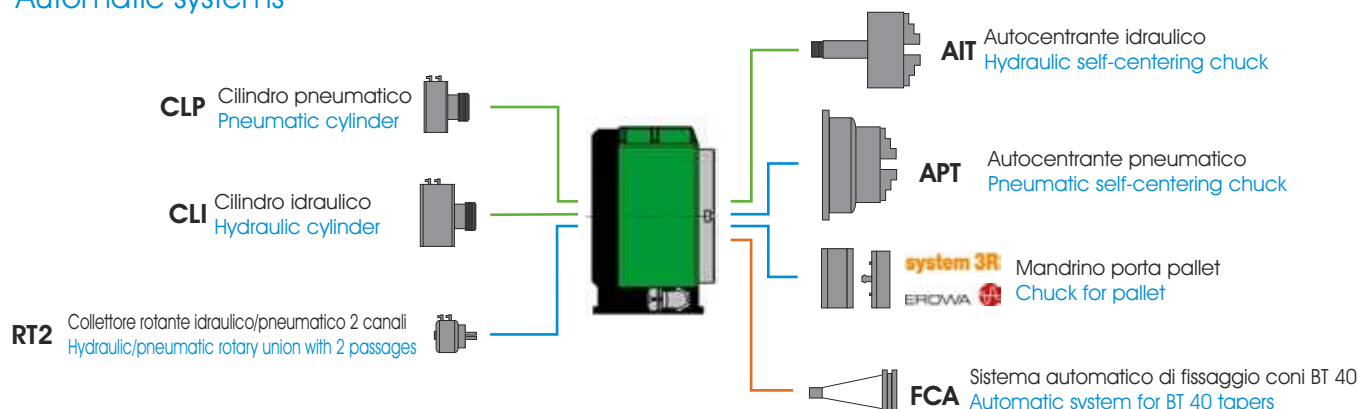

### Autocentranti manuali 3 griffe

#### Manual 3 jaw chucks

AMT

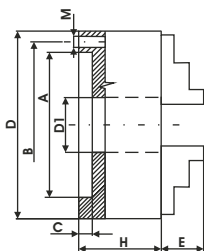

Modelli - Caratteristiche Models - Specifications	D	D1	A	B	C	E	H	M	Peso Weight
AMT100	100	20	70	83	3	17	50	3xM8	Kg 2,8
AMT125	125	32	90	108	4	20	59,5	3xM8	Kg 4,8
AMT160	160	42	125	140	4	32	68,1	3xM10	Kg 8,5
AMT200	200	55	160	176	4	29	78	3xM10	Kg 16
AMT250	250	76	200	224	5	34	89	3xM12	Kg 26
AMT315	315	103	260	286	5	43	96,2	6xM16	Kg 43

### Autocentranti automatici a 3 griffe con cilindro pneumatico

#### Automatic 3 jaw chucks with pneumatic cylinder

APT

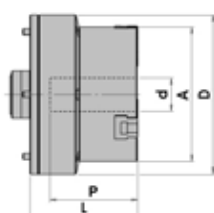

Modelli - Caratteristiche Models - Specifications	Forza di serraggio (6 Bar) Gripping force (6 Bar)	Per tavole grandezza For tables size	D	d x P	A	L
APT200	5000 daN	250	250	66x115	210	170
APT250	6875 daN	320	270	77x130	254	190

Autocentranti automatici a 3 griffe  
Automatic 3 jaw chucks

**AIT**



TDE 250 + AIT 210 + CLP250-2

Modelli - Caratteristiche Models - Specifications	Adatto a tavole grandezza Suitable for tables size	Cilindro compatibile Suitable cylinder	D	d	L
AIT210	250	CLP250-2 / CLI250	210	51	103
AIT250	320	CLP320-2 / CLI320	254	61	125

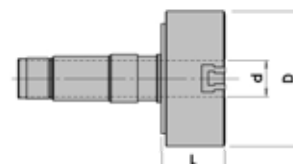

Cilindro pneumatico  
Pneumatic cylinder

**CLP**

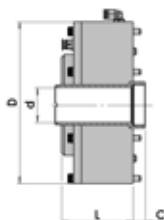

Modelli - Caratteristiche Models - Specifications	Forza di trazione (6 Bar) Traction force (6 Bar)	Per tavole grandezza For tables size	D	d	C	L
CLP125-1	1800 N	125	135	14	11	62
CLP200-1	1800 N	200	135	14	11	62
CLP200-2	20100 N	200	250	51	20	130
CLP250-2	20100 N	250	250	51	20	107
CLP320-2	20100 N	320	250	51	20	107

Cilindro idraulico  
Hydraulic cylinder

**CLI**

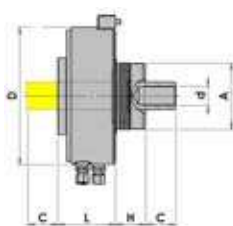

Modelli - Caratteristiche Models - Specifications	Per tavole grandezza For tables size	D	d	C	L	H	A
CLI200	200	155	M22x1,5	25	100	///	M44x1,5
CLI250	250	155	M22x1,5	25	65	34	M75x1,5
CLI320	320	155	M22x1,5	25	65	34	M85x2

La forza di trazione a 80 bar è di 15878 N  
Traction force at 80 bar is 15878 N

Collettore rotante idraulico/pneumatico 2 canali  
Hydraulic/pneumatic rotary union with 2 passages

**RT2**

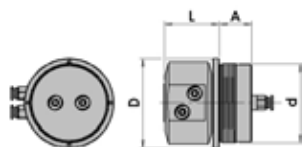

Modelli - Caratteristiche Models - Specifications	Pressione Massima Max pressure	Per tavole grandezza For tables size	d	D	L	A
RT2125	80 Bar	125	M30x1,5	84	53	31
RT2200	80 Bar	200	M44x1,5	84	53	31
RT2250	80 Bar	250	M75x1,5	84	53	31
RT2320	80 Bar	320	M85x2	84	53	31

# Accessori - Sistemi di presa

## Accessories - Workholding

Sistemi manuali di fissaggio coni ISO 40/50

Manual systems for ISO 40/50 tapers

FCM



Modelli - Caratteristiche Models - Specifications	Tipo di attacco Type of taper	Adatto a tavole grandezza Suitable for tables size
FCM40I200	ISO40	200
FCM40I250	ISO40	250
FCM50I200	ISO50	200
FCM50I250	ISO50	250

Sistemi automatici di fissaggio coni ISO 40/50

Automatic systems for ISO 40/50 tapers

FCA

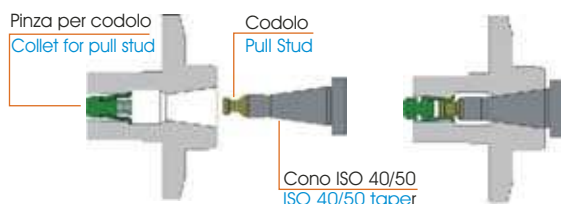

Forza di bloccaggio N 16000  
Pressione idraulica di esercizio (necessaria allo sgancio)  
Disponibili diversi tipi di codoli

Clamping force N 16000  
Working hydraulic pressure (necessary for unhook)  
Available different types of pull-stud

Modelli - Caratteristiche Models - Specifications	Tipo di attacco Type of taper	Adatto a tavole grandezza Suitable for tables size
FCA40I200	ISO40	200
FCA40I250	ISO40	250
FCA50I200	ISO50	200
FCA50I250	ISO50	250



BSC 250 + FCA ISO 40

Sistemi di pallettizzazione

Pallet systems

Le tavole possono essere predisposte alla integrazione dei sistemi di fissaggio pallet più diffusi. Con l'utilizzo dei collettori rotanti RT2 (pag. 39) è possibile gestire l'aggancio e lo sgancio dei pallet automaticamente.

The tables can be prepared for the integration of the more common pallets fixing systems. Using the RT2 rotary unions (page 39) it is possible to automatically control the pallets hooking/unhooking.

system 3R

EROWA



BSC 125 + Erowa



BSC 200 + System 3R



Encoder ad alta risoluzione  
High resolution encoder

EDR

Tutte le tavole L.C.M. sono predisposte per alloggiare un encoder ad alta risoluzione montato diretto in asse (girevole e basculante). Con questa opzione la precisione garantita è di  $\pm 5''$ .

All L.C.M. Tables are preset for mounting a high resolution encoder, direct on axis (both rotary and tilting axis). Thanks to this option the guaranteed accuracy is  $\pm 5''$ .



Modelli tavole Models of tables	Precisione Accuracy	Modello di encoder Type of encoder
TDE 125 - 200 - 250 BASV 125 - 200 - 250 BSC 125 - 200 - 250	$\pm 5''$	EDR2
TDE 320 BASV 320 BSC 320	$\pm 5''$	EDR3

Informazioni tecniche sulla precisione  
Technical informations about indexing accuracy

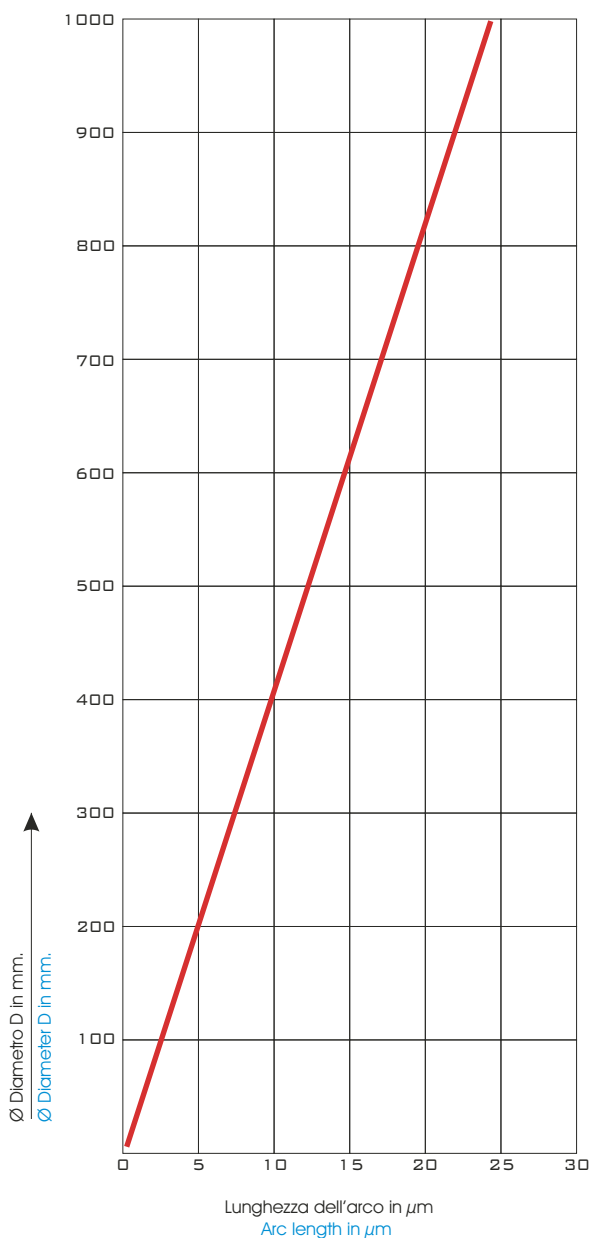

Conversione di arco/secondi in lunghezza d'arco in  $\mu\text{m}$   
Conversion of angle seconds to arc length in  $\mu\text{m}$

L = Lunghezza dell'arco in  $\mu\text{m}$   
Arc length in  $\mu\text{m}$

S = secondi di angolo  
Angle seconds

D = diametro della circonferenza in mm.  
Diameter of the circumference in mm.

$$L = \frac{S \times D}{413} \quad (\mu\text{m})$$

Esempio  
Example



## Controllo Numerico per tavole Numerical control for tables



Il WNC 50 è un controllo numerico in grado di gestire completamente la programmazione e la movimentazione di tutti i modelli di tavole LCM a trasmissione meccanica, di 1 o 2 assi. È dotato di una pratica interfaccia operatore con trasmissione dati Wireless, tastiera a membrana e display LCD alfanumerico retroilluminato. Durante le fasi di programmazione, l'assenza di cavi consente all'operatore di tenere la console tra le mani, potendosi avvicinare maggiormente alla zona di lavoro ed in massima sicurezza. Qualsiasi divisione e posizionamento, con incrementi minimi fino a 0,001°, può essere effettuato con la massima semplicità. L'utilizzo è agevolato dalle molteplici funzioni specifiche per assi girevoli. I programmi possono essere avviati con codice M della macchina oppure manualmente con tasto "start". I dati dei programmi possono essere caricati e scaricati tramite l'interfaccia Rs232 oppure tramite porta USB.

The WNC 50 is a numerical control providing complete programming and motion control of all LCM tables, both 1 and 2 axes, with mechanical transmission. It is supplied complete with a practical operator interface with data wireless transmission, membrane keypad and back lighted alphanumeric LCD display. During programming operations, the presence of no cables allows the operator to move with the console in his hands, going closer to the operation zone and in a safety way. Any position, with minimum increments of 0,001°, can easily be programmed. Its use is facilitated thanks to several functions specific for rotary axes. Programs can be run directly from the machine tool by M-code or manually by pressing the "start" key. Program data can easily be loaded and downloaded via RS232 interface or by USB port.

Caratteristiche - Modelli Specifications - Models	WNC 50 1AX	WNC 50 2AX
N° di assi programmabili Number of axes	1	2
Visualizzazione Visualisation	LCD retroilluminato LCD backlighted	LCD retroilluminato LCD backlighted
Tastiera Keypad	Poliestere 16 tasti Sealed membrane, 16 key	Poliestere 16 tasti Sealed membrane, 16 key
Quantità massima di programmi in memoria Maximum quantity of programs in memory	300	200
Quantità massima di blocchi per ogni programma Maximum quantity of blocks for every program	100	100
Distanza di trasmissione massima Max transmission distance	20	20
Tensione Voltage	220 V - 50 Hz	220 V - 50 Hz
Pressione ingresso aria Air entry pressure	6 Bar	6 Bar

### SCHEMA CONNESSIONE CONNECTION DIAGRAM

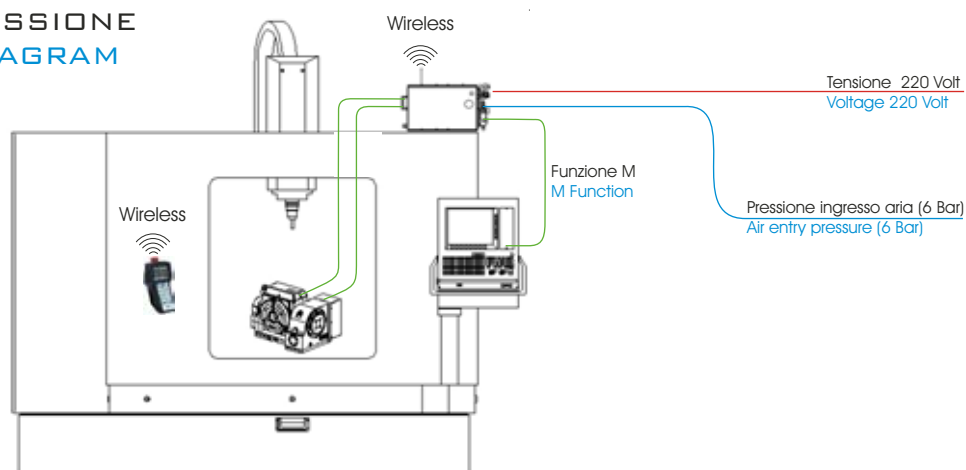

Le Tavole e le teste L.C.M. sono predisposte per alloggiare motori brushless delle principali marche.  
 Per poter essere collegate in continuo ad uno specifico CNC, le tavole devono integrare motori compatibili.  
 Il tipo di motore da utilizzare dipende quindi dal CNC della macchina utensile.  
 La tabella sottostante indica e suddivide in gruppi i vari modelli in base a capacità e dimensioni simili.

L.C.M. tables and heads are prepared to install motors from all popular CNC brands.

The table below shows suggested motors divided by size group and brand.

For each LCM product the required motor can be selected by the suggested size and appropriate brand for the CNC of the machine tool.

Grandezza Size	1	2	3	4	5	6
Fanuc	Beta 1 5000is	Alpha 1-5000i Alpha 1-3000 Alpha 2-5000i Alpha 2-5000is Alpha 2-5000HVis Beta 2-4000is	Alpha 2-5000i Alpha 2-5000is Alpha 2-5000HVis Beta 2-4000is Alpha 4-5000is Alpha 4-5000HVis Beta 4-4000is	Alpha 4-5000is Alpha 4-5000HVis Beta 4-4000is Alpha 6-4000 Alpha 6-3000 Alpha 8-3000i Alpha 8-4000is Alpha 8 4000HVis Beta 8-3000is Alpha 12-4000is Alpha 12-4000HVis Beta 12-3000is	Alpha 12-4000is Alpha 12-4000HVis Beta 12-3000is	Alpha 22-2000 Alpha 22-4000HVis Beta 22-4000is
Siemens	////	1FK70337AK711AG0	1FK70425AF711AG0	1FK70635AF711AG0 1FK70605AF711AG0	1FK70835AF711AG0	1FK71015AF711AG0 1FK71055AC711AG0 1FT61058AF714AG0
Yaskawa	SGMAH-04AAA2S	SGMAH-08AAAS	SGMAH-08AAAS	SGMGH-09-ACA2S SGMGH-13-ACA2S	SGMGH-20-ACA2S SGMGH-40-ACA2S	SGMGH-30-ACA2S SGMGH-50-ACA2S
Mitsubishi	HC-MFS 23 HC-MFS 43 HC-KFS 23 HC-KFS 43	HA23N HA33N HC-KFS43 HC-KFS73 HC-MFS73	HA33N HC-KFS73 HC-MFS73 HC-RFS103 HC-RFS153 HC-RFS203	HC103 HC153 HC202 HF104T HF154T HC-SFS102 HC-SFS152 HC-RFS103 HC-RFS153 HC-RFS203 HC-RFS353	HC202 HF354S HC-SFS202 HC-SFS352 HC-RFS353 HC-RFS503	HC-SFS352 HC-SFS502 HC-RFS503
Panasonic	PMSMD042P1C	PMSMD082P1C	PMSMD082P1C	PMHMA152P1G	PMHMA302P1C	PMHMA402P1C
Heidenhain	////	////	QSY 96 A	QSY116C QSY116E QSY130C ECODYN QSY130E ECODYN	QSY155B QSY155B ECODYN	QSY155C QSY155C ECODYN QSY155D QSY155D ECODYN QSY155E QSY155E ECODYN

Possono essere utilizzati altri tipi di motori. Richiedeteci l'elenco completo oppure indicateci le caratteristiche e le dimensioni.

Other models of motors can be used. Please, contact L.C.M. for the complete list or tell us specifications and dimensions.



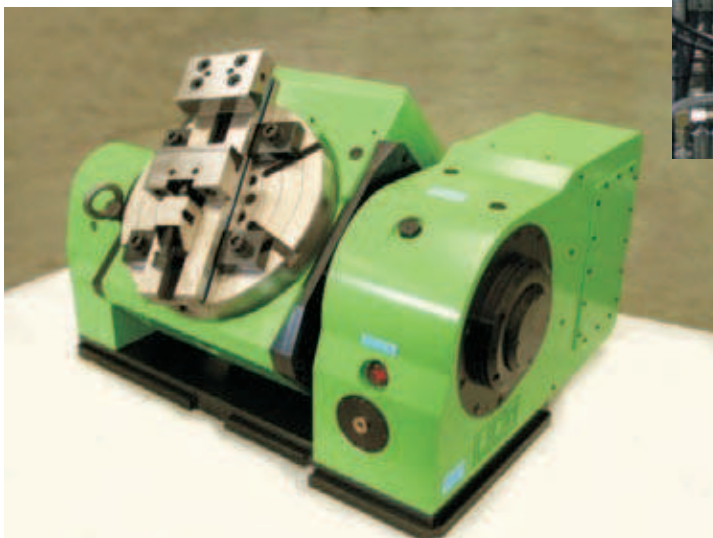
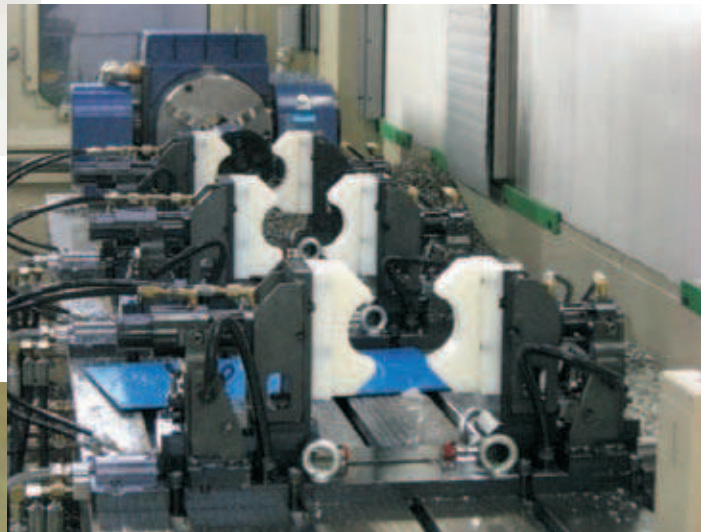
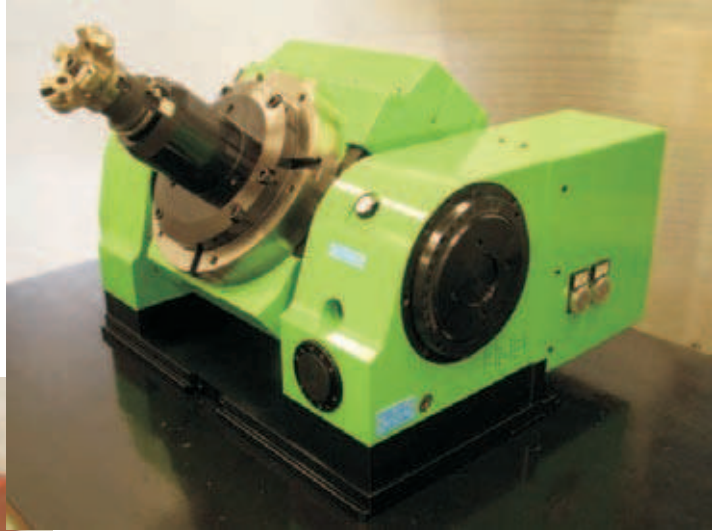

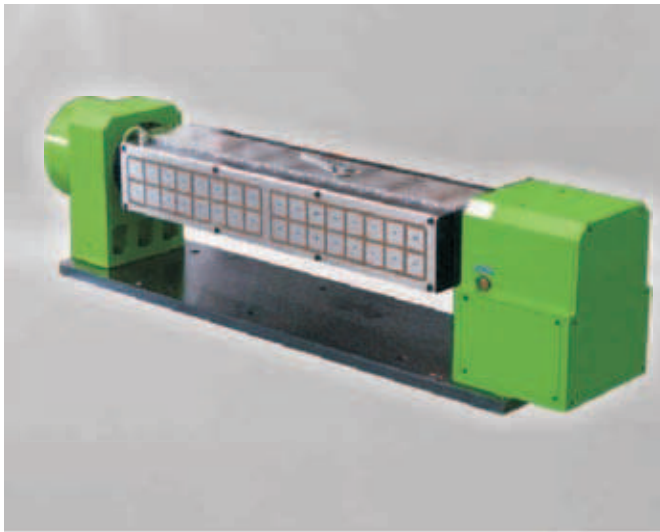
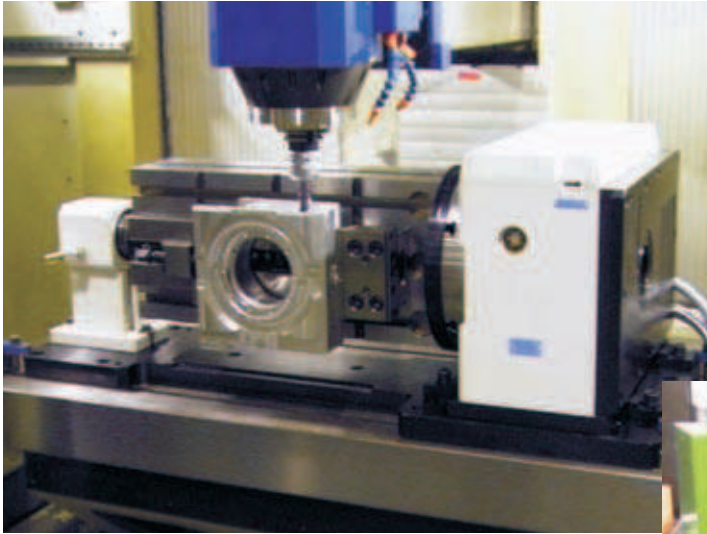



L.C.M. è un'azienda meccanica che dal 1986 progetta, produce e commercializza accessori per macchine utensili. Grazie all'impiego di uno staff di tecnici altamente qualificati nei propri reparti, L.C.M. è in grado di offrire prodotti innovativi e con standard qualitativi elevati. I nostri ingegneri sono a disposizione per eventuale assistenza e per collaborare nella scelta o personalizzazione dei prodotti.

Since 1986 L.C.M. has been producing and selling mechanical accessories for machine tools. With a staff of highly qualified technicians and a wealth of experience, L.C.M. offers innovative products of the highest quality standards. Our engineering team is available to give you both service and cooperation for customized products to meet specific design requirements.

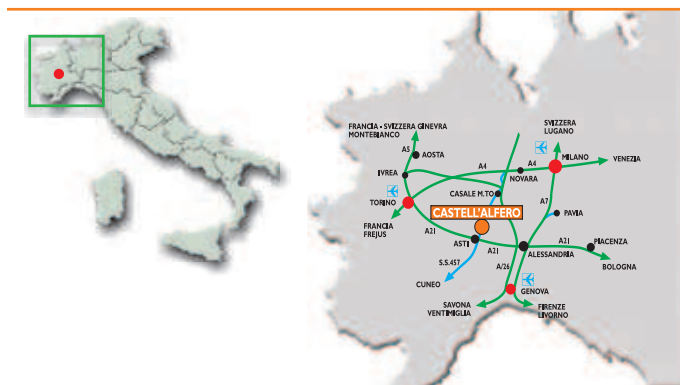

In una prospettiva di costante miglioria del prodotto, le informazioni contenute nel presente catalogo sono soggette a modifiche senza preavviso.  
Because of the constant product development we reserve the right to make changes in specifications and design without notice.

---

L.C.M. S.r.l.  
Via Statale n° 25/K  
14033 Castell'Alfero, Asti, Italy  
Tel. (+39) 0141 296035  
Fax (+39) 0141 296034  
E-mail: [lcm@lcmitalia.it](mailto:lcm@lcmitalia.it)  
Web site: <http://www.lcmitalia.it>

---