



**RHINO TURN**™ FEATURING



TURNING PRODUCTS

**External Holders:**

- TCLNR/L-TB
- TCRNR/L-TB
- TDJNR/L-TB
- TWLNR/L-TB
- TVJNR/L-TB
- TXJNR/L-TB

**Shank Sizes:**

- .750"
- 1.000"
- 1.250"

**Internal Holders:**

A-TCLNR/L-TB - 1" shank

**Fittings & Hoses:**

Sold separately.  
See last page.



**Thru-Coolant Holders**

Ingersoll is introducing a new series of coolant-thru holders to the very successful and economical RHINO-TURN product line for external and internal turning.

**COOLBURST**™ is a series of internally channeled coolant-thru holders capable of delivering high pressure coolant directly to the insert cutting edge.

**Features & Benefits:**

- Pinpoint coolant delivery from top clamp (for cooling) and bottom of holder (for chip breaking)
- T-Type holding system with multi-directional clamping force provides 40% more stability over conventional lever lock holders, plus simple & fast indexing. No additional components required.
- Up to 50% increase in tool life under the same machining conditions
- 20% increase in cutting speed capability in difficult-to-cut materials
- Increased productivity in high-speed machining of titanium and super alloys
- Excellent chip control
- Coolant pressure: Recommend 1000 psi for best results. Capable of 2000 psi.
- Efficient cooling of the insert cutting edge at two different locations



# RHINOTURN™ MEETS COOLBURST™

Each external RhinoTurn holder features two outlet holes for pinpoint coolant delivery to critical locations:

- Insert rake face (top surface) - Delivery is through the top clamp. This prevents crater wear and allows higher cutting speeds & feeds since heat is reduced.
- Insert flank (side surface) - Delivery is directed upwards from under the insert. This optimizes chip formation, reduces chip size, improves chip evacuation and reduces flank wear.



Unlike other conventional lever-lock holders with internal coolant, the Ingersoll solution allows multi-directional clamping force of the insert in the pocket, which increases stability by more than 40%. This makes it possible to increase feed rates and cutting depths compared to conventional holders that utilize a single direction clamping force. Furthermore, this system requires no additional clamping components, making it extremely efficient and easy to use.



**MULTIDIRECTIONAL CLAMPING FORCES**

RhinoTurn COOL-BURST holders can be applied in any material but are particularly beneficial in the machining of heat-resistant alloys, titanium alloys and difficult-to-cut materials such as stainless steel.

The localized coolant outlet holes, the high-pressure capability and the rigid multi-directional clamping system all provide an opportunity to run higher cutting speeds and feeds while improving tool life. This makes it an ideal addition to Ingersoll's SFeedUP campaign.

Note: All high-pressure coolant-thru tools will be marked with the COOL-BURST logo  
Note: Fittings and hoses sold separately.





**COOLBURST™ TEST IN TITANIUM ALLOY (Ti6Al4V)**

**1. Tool life test**

		Ingersoll	Ingersoll
Holder		TCLNL 16-33D	TCLNL 16-33D-TB
Insert		CNGG 332 ML TT5080	
Cutting speed	V (sfm)	260	260
Feed rate	f (ipr)	.006	.006
Depth of cut	ap (inch)	.040	.040
Coolant		150 psi external coolant	1000 psi internal high-pressure coolant
Tool life (min)		16, 14	70, 67



**2. Chip control test**

Cutting speed = 260 sfm

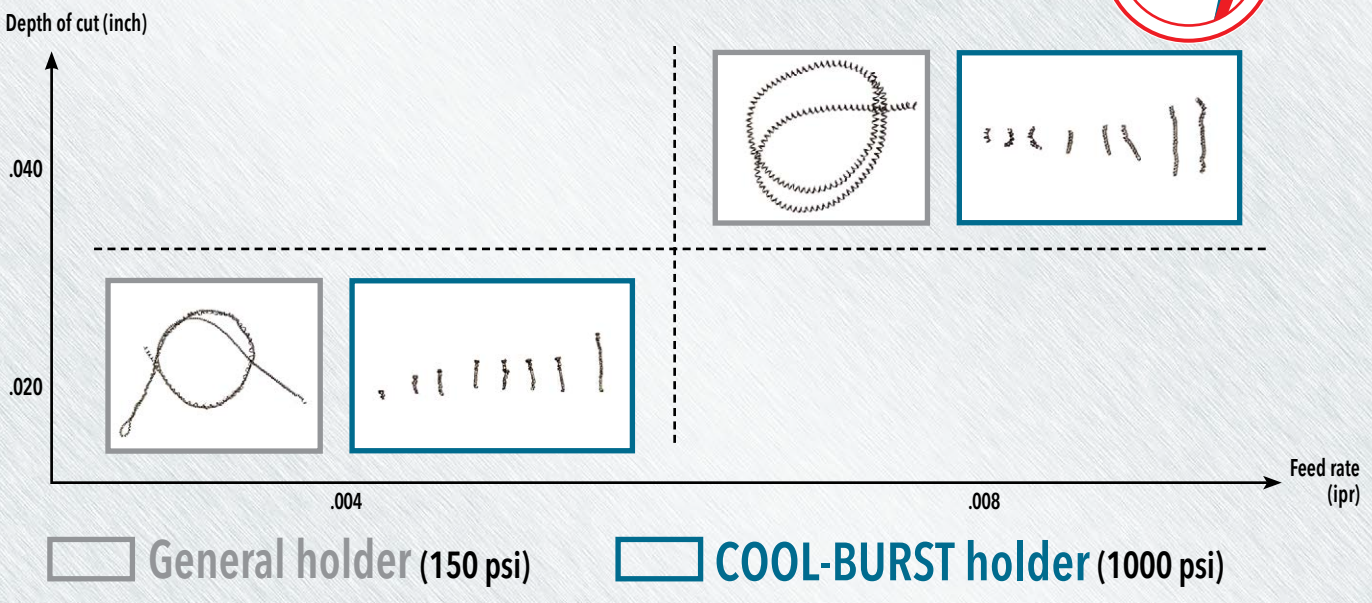



**COOLBURST™ TEST IN ALLOY STEEL (AISI 4140)**

**1. Tool life test**

		Ingersoll		Ingersoll	
Holder		TCLNL 16-33D		TCLNL 16-33D-TB	
Insert		CNMG 332 MTTT8115			
Cutting speed	V (sfm)	1050	1050	1150	
Feed rate	f (ipr)	.011	.011		
Depth of cut	ap (inch)	.080			
Coolant		150 psi external coolant		1000 psi internal high-pressure coolant	
Tool life (min)		14.5	22.5	17	

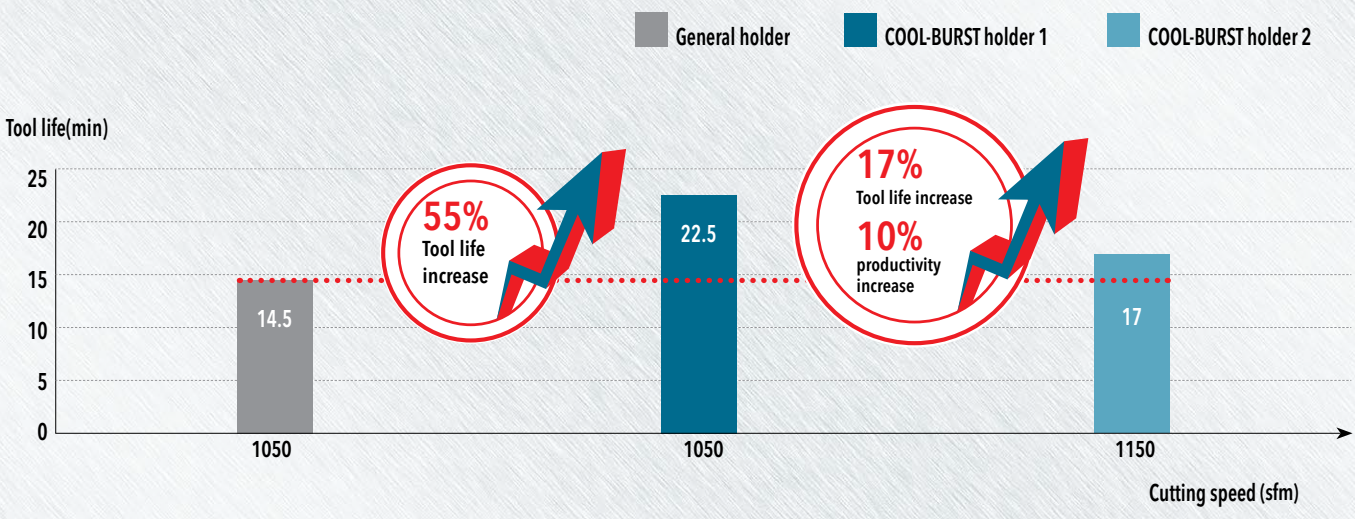

**2. Chip control test**

Cutting speed = 650 sfm

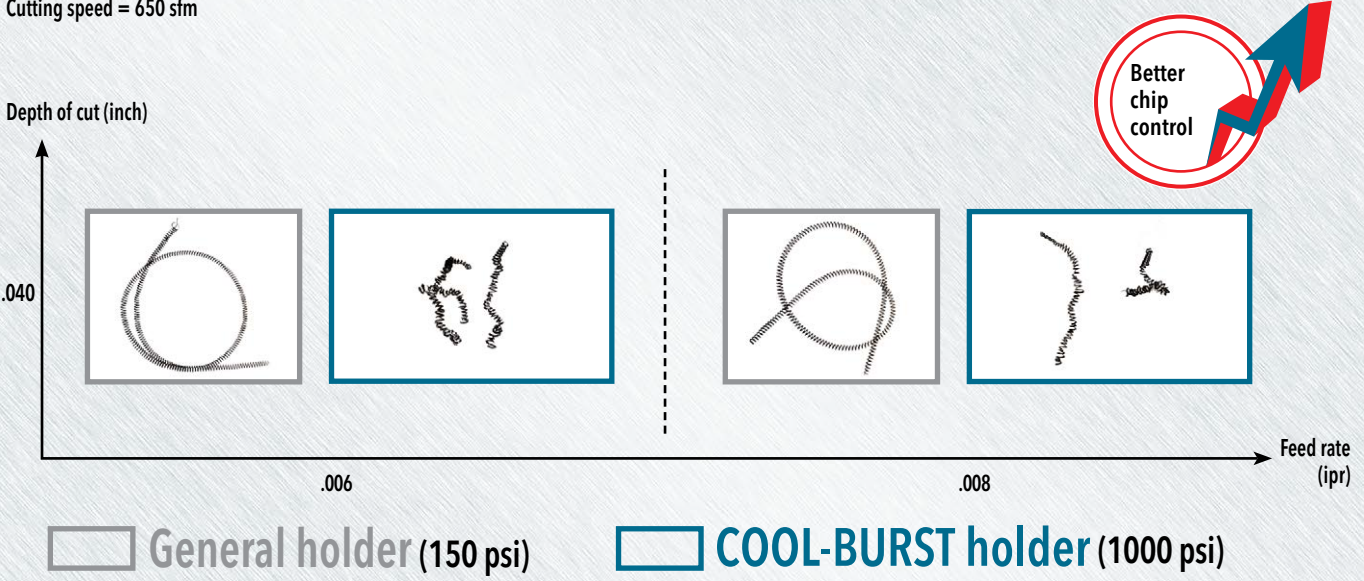



**COOLBURST™ TEST IN STAINLESS STEEL (AISI 304)**

**1. Tool life test**

		Ingersoll		Ingersoll	
Holder		TCLNL 16-33D		TCLNL 16-33D-TB	
Insert		CNMG 332 EM TT5080			
Cutting speed	V (sfm)	650	650	720	790
Feed rate	f (ipr)	.010			
Depth of cut	ap (inch)	.040			
Coolant		150 psi external coolant		1000 psi internal high-pressure coolant	
Tool life (min)		12	33	20	17.5

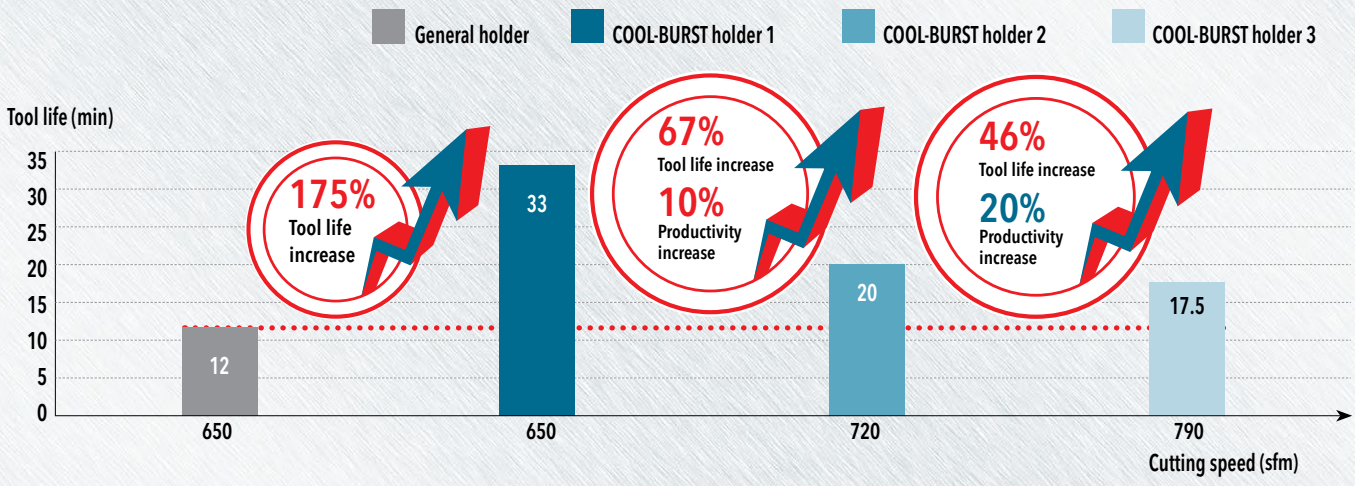

**2. Chip control test**

Cutting speed = 500 sfm

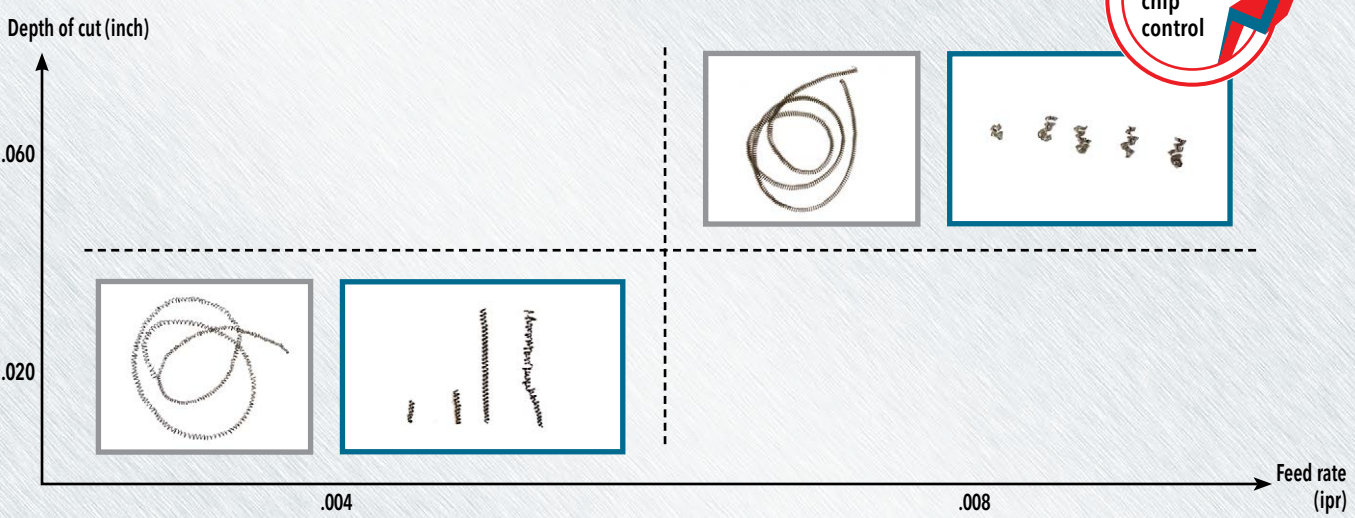

General holder (150 psi)      COOL-BURST holder (1000 psi)



**COOLBURST™ TEST IN INCONEL 718**

**1. Tool life test**

		Ingersoll		Ingersoll	
Holder		TCLNL 16-33D		TCLNL 16-33D-TB	
Insert		CNMG 332 MK TT5080			
Cutting speed	V (sfm)	100	100	130	
Feed rate	f (ipr)	.008			
Depth of cut	ap (inch)	.060			
Coolant		150 psi external coolant		1000 psi internal high-pressure coolant	
Tool life (min)		3.5	12.3	5.5	

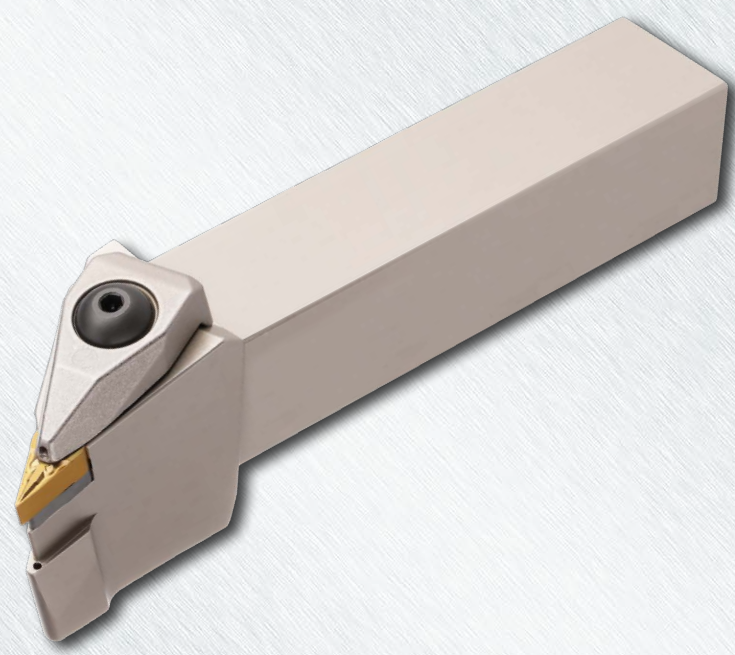
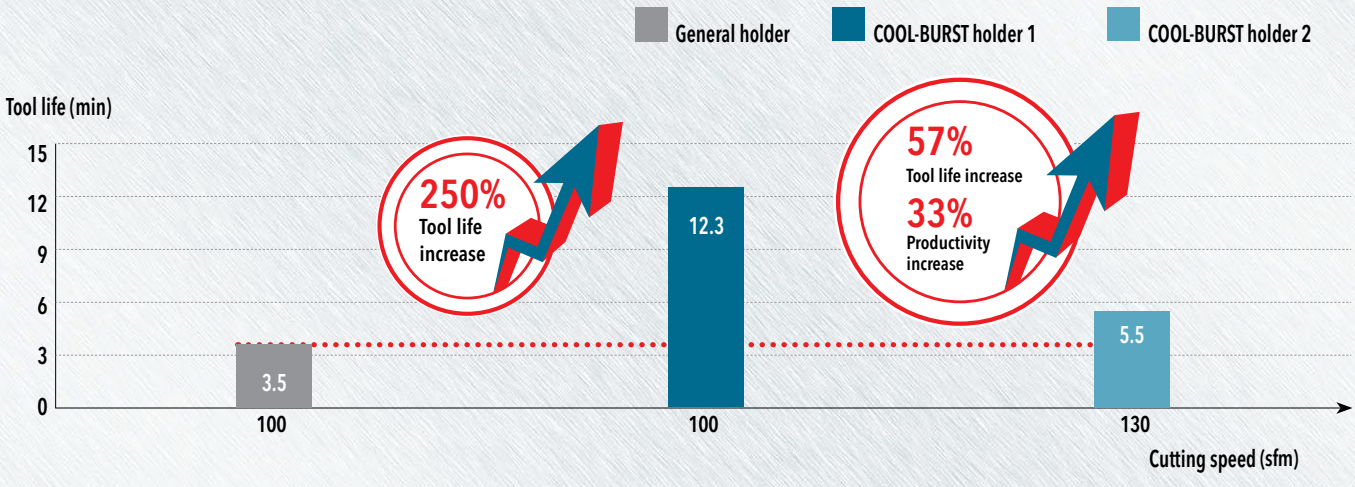



**RHINOTURN™ TCLNR/L-TB T-HOLDERS WITH HIGH-PRESSURE COOLANT (CN\_33X INSERTS)**

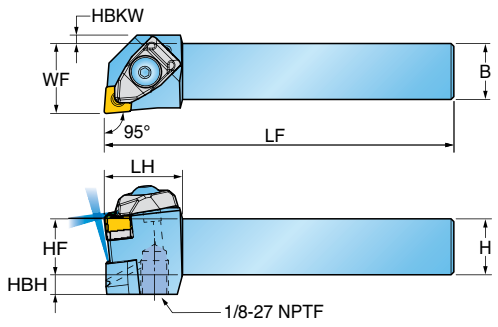
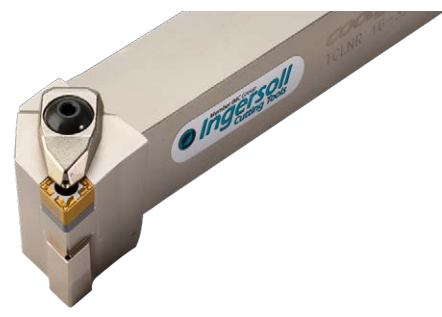

Approach angle	Part Number	Dimension (inch)								Insert
		H Shank Height	HF Functional Height	B Shank Width	LF Functional Length	WF Functional Width	LH Head Length	HBH Head Bottom Offset Height	HBKW Head Back Offset Width	
	TCLNR/L 12-33B-TB	.750	.750	.750	4.5	1.000	1.10	.31	.12	CN... 33...
	TCLNR/L 16-33D-TB	1.000	1.000	1.000	6.0	1.250	1.10	.25	-	
	TCLNR/L 20-33D-TB	1.250	1.250	1.250	6.0	1.500	1.10	-	-	

**Spare Parts**

Part Number	Clamp	Clamp Screw	Spring	Upper O-ring	Lower O-ring	Shim	Shim Screw	Wrench	
TCLNR/L-TB TCRNR/L-TB	DLM 3-NX-TB	BH M4x0.7x16-TB	DSP 3	O-RING ID4.47x1.78	O-RING ID6.07x1.78	LSC 32A	SO 400851	L-W 3	T 15



**RHINOTURN™ TCRNR/L-TB T-HOLDERS WITH HIGH-PRESSURE COOLANT (CN\_33X INSERTS)**

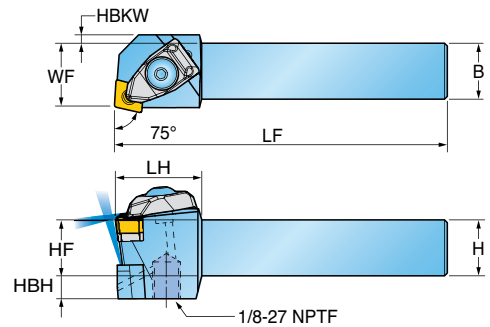

Approach angle	Part Number	Dimension (inch)								Insert
		H Shank Height	HF Functional Height	B Shank Width	LF Functional Length	WF Functional Width	LH Head Length	HBH Head Bottom Offset Height	HBKW Head Back Offset Width	
75°  COOLBURST	TCRNR/L 12-33B-TB	.750	.750	.750	4.5	.855	1.18	.31	.12	CN... 33...
	TCRNR/L 16-33D-TB	1.000	1.000	1.000	6.0	1.048	1.18	.25	-	

**Spare Parts**

Part Number	Clamp	Clamp Screw	Spring	Upper O-ring	Lower O-ring	Shim	Shim Screw	Wrench	
TCLNR/L-TB TCRNR/L-TB									
	DLM 3-NX-TB	BH M4x0.7x16-TB	DSP 3	O-RING ID4.47x1.78	O-RING ID6.07x1.78	LSC 32A	SO 400851	L-W 3	T 15





**RHINOTURN™ TDJNR/L-TB T-HOLDERS WITH HIGH-PRESSURE COOLANT (DN\_ 3.53.5X INSERTS)**

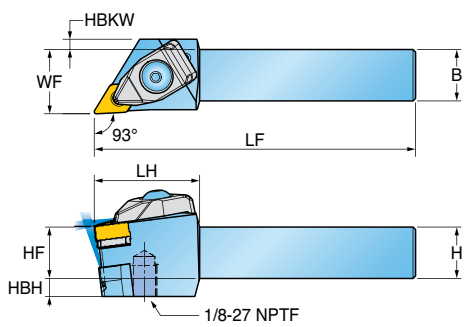

Approach angle	Part Number	Dimension (inch)								Insert
		H Shank Height	HF Functional Height	B Shank Width	LF Functional Length	WF Functional Width	LH Head Length	HBH Head Bottom Offset Height	HBKW Head Back Offset Width	
	TDJNR/L 12-3.53.5B-TB	.750	.750	.750	4.5	1.000	1.61	.31	.16	DN... 3.53...
	TDJNR/L 16-3.53.5D-TB	1.000	1.000	1.000	6.0	1.250	1.61	.25	-	
	TDJNR/L 20-3.53.5D-TB	1.250	1.250	1.250	6.0	1.500	1.61	-	-	

**Spare Parts**

Part Number	Clamp	Clamp Screw	Spring	Upper O-ring	Lower O-ring	Shim	Shim Screw	Wrench	
12-3.53.5...-TB									
12-3.53.5...-TB	DLM 3.5-NX-TB	BH M5x0.8x 21-MO-TB	DSP 4	O-RING ID5.28x 1.78	O-RING ID7.59x 2.62	LSD 3.52	SO 50090I-MO	L-W 3	T 20
16-3.53.5...-TB 20-3.53.5...-TB	DLM 3.5-NX-TB	BH M5x0.8x 21-MO-TB	DSP 4	O-RING ID5.28x 1.78	O-RING ID7.59x 2.62	LSD 3.52	SO 50090I	L-W 3	T 20



**RHINOTURN™ TVJNR/L-TB T-HOLDERS WITH HIGH-PRESSURE COOLANT (VN\_X2.53X INSERT)**

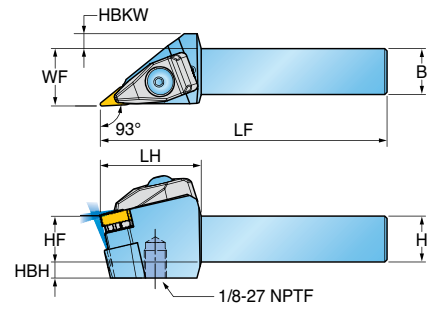

Approach angle	Part Number	Dimension (inch)								Insert
		H Shank Height	HF Functional Height	B Shank Width	LF Functional Length	WF Functional Width	LH Head Length	HBH Head Bottom Offset Height	HBKW Head Back Offset Width	
	TVJNR/L 12-2.53B-TB	.750	.750	.750	4.5	1.000	1.73	.31	.256	VN...X2.53...
	TVJNR/L 16-2.53D-TB	1.000	1.000	1.000	6.0	1.250	1.73	.25	-	
	TVJNR/L 20-2.53D-TB	1.250	1.250	1.250	6.0	1.500	1.73	-	-	

**Spare Parts**

Part Number	Clamp	Clamp Screw	Spring	Upper O-ring	Lower O-ring	Shim	Shim Screw	Wrench	
TVJNR/L-TB									
	DLM 2.5V-NX-TB	BH M5x0.8x25-TB	DSP 4	O-RING ID5.28x1.78	O-RING ID7.59x2.62	MSVI 2.522	SO 40085I	L-W 3	T 15



**RHINOTURN™ TWLNR/L-TB T-HOLDERS WITH HIGH-PRESSURE COOLANT (WN\_33X INSERT)**

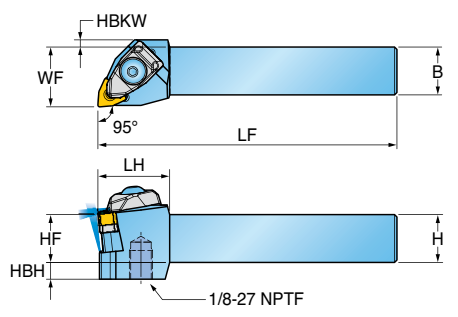

Approach angle	Part Number	Dimension (inch)								Insert
		H Shank Height	HF Functional Height	B Shank Width	LF Functional Length	WF Functional Width	LH Head Length	HBH Head Bottom Offset Height	HBKW Head Back Offset Width	
 95°	TWLNR/L 12-33B-TB	.750	.750	.750	4.5	1.000	1.18	.31	.10	WN... X33...
	TWLNR/L 16-33D-TB	1.000	1.000	1.000	6.0	1.250	1.18	.25	-	
	TWLNR/L 20-33D-TB	1.250	1.250	1.250	6.0	1.500	1.18	-	-	

**Spare Parts**

Part Number	Clamp	Clamp Screw	Spring	Upper O-ring	Lower O-ring	Shim	Shim Screw	Wrench	
TWLNR/L-TB	DLM 3-NX-TB	BH M4x0.7x 16-TB	DSP 3	O-RING ID4.47x 1.78	O-RING ID6.07x 1.78	LSW 32A	SO 40085I	L-W 3	T 15



**RHINOTURN™ TXJNR/L-TB T-HOLDERS WITH HIGH-PRESSURE COOLANT (XNMG INSERT)**

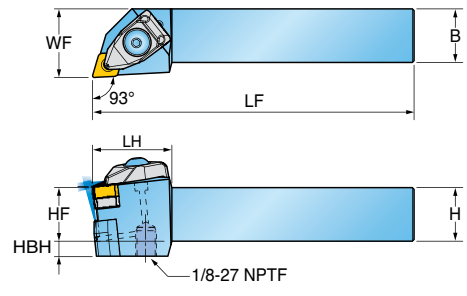

Approach angle	Part Number	Dimension (inch)								Insert
		H Shank Height	HF Functional Height	B Shank Width	LF Functional Length	WF Functional Width	LH Head Length	HBH Head Bottom Offset Height	HBKW Head Back Offset Width	
93°  COOLBURST	TXJNR/L 16-2.7D-TB	1.000	1.000	1.000	6.0	1.250	1.18	.25	XNMG... 2.7...	XNMG... 2.7...
	TXJNR/L 16-3.5D-TB	1.000	1.000	1.000	6.0	1.250	1.18	.25	XNMG... 3.5...	XNMG... 3.5...

**Spare Parts**

Part Number	Clamp	Clamp Screw	Spring	Upper O-ring	Lower O-ring	Shim	Shim Screw	Wrench	
TXJNR/L 2.7...									
TXJNR/L 2.7...	DLM 3-NX-TB	BH M4x0.7x 16-TB	DSP 3	O-RING ID4.47x 1.78	O-RING ID6.07x 1.78	TSX 2.73	SO 40085I	L-W 3	T 15
TXJNR/L 3.5...	DLM 3.5-NX-TB	BH M5x0.8x 21-MO-TB	DSP 4	O-RING ID5.28x 1.78	O-RING ID7.59x 2.62	TSX 3.53	SO 50090I	L-W 3	T 20





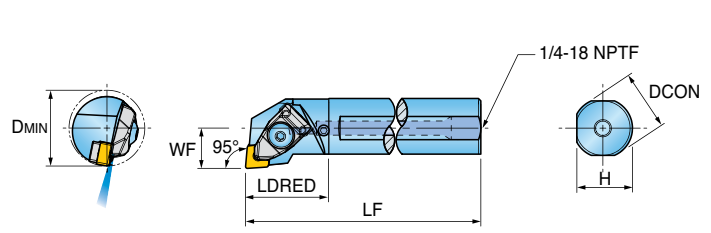

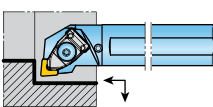



**RHINOTURN™ A-TCLNR/L-TB T-HOLDER TYPE BORING BARS WITH HIGH-PRESSURE COOLANT (CN\_33X INSERT)**



Approach angle	Part Number	Dimension (inch)						Insert
		DCON Shank Diameter	DMIN Min. Bore Diameter	LF Functional Length	WF Functional Width	LDRED Reduced Body Dia. Length	H Shank Height	
95°  <b>COOLBURST</b>	A16T-TCLNR/L-33-TB	1.000	1.250	12.0	.64	1.38	.92	CN... 33...
	A20U-TCLNR/L-33-TB	1.250	1.500	14.0	.77	1.38	1.17	

**Spare Parts**

Part Number	Clamp	Clamp screw	Spring	Upper O-ring	Lower O-ring	Shim	Shim screw	Wrench	
A-TCLNR/L-TB									
	DLM 3-NX-TB	BH M4x0.7x 16-TB	DSP 3	O-RING ID4.47x 1.78	O-RING ID6.07x 1.78	LSC 32	SO 40073I	L-W 3	T 15



**COOLBURST™ CONNECTORS**

Fig.1 - STRAIGHT MALE CONNECTOR

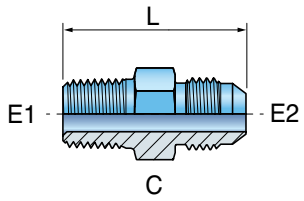

Fig.2 - ELBOW MALE CONNECTOR

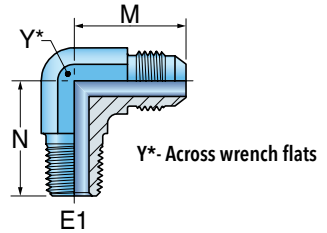
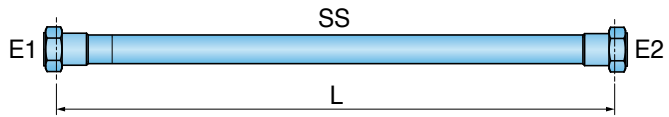

Fig.	Part Number	End Size		C (hex)	L	Max Pressure (psi)
		E1	E2			
1	TB-4-FTX-S	1/8-27 NPTF	1/4 (37° Flare)	1/2"	1.22"	6000

Fig.	Part Number	End Size		Y	M	N	Max Pressure (psi)
		E1	E2				
2	TB-4-CTX-S	1/8-27 NPTF	1/4 (37° Flare)	7/16"	0.89"	0.78"	6000

All connectors ordered separately.

**COOLBURST™ FLEXIBLE HIGH-PRESSURE HOSES**



Part Number	Dimension (inch)			Max Pressure (psi)
	L	E1	E2	
TB-HOSE-7/16-7/16-8.OSS	8.0 inch	1/4 (37° Flare)	1/4 (37° Flare)	3000
TB-HOSE-7/16-7/16-10.OSS	10.0 inch	1/4 (37° Flare)	1/4 (37° Flare)	3000

All hoses ordered separately.

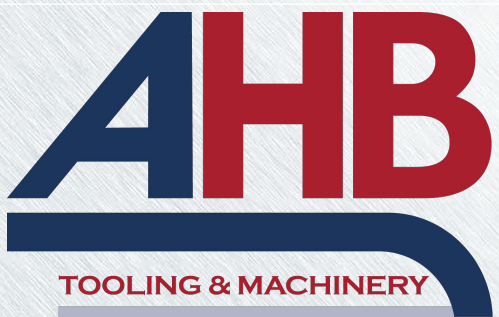

**COMPLETE METALWORKING SOLUTIONS**

(800) 991-4225

www.ahbinc.com

ISO Certified

customerservice@ahbinc.com

NEW-304  
(12/2020)  
14/14