

Member IMC Group

Ingersoll
Cutting Tools

USER MANUAL



Typhoon
HSM Jet Spindles







Table of Contents

1	General	
1.1	Safety First.....	4
1.2	Statement of Compliance.....	5
1.2.1	European standards (CE).....	5
1.2.2	American standards (UL).....	5
1.2.3	International standards.....	5
1.3	Introduction.....	6
1.4	Case Contents.....	6
1.5	Main Features.....	6
1.5.1	Wireless Rotation Speed Display.....	7-8
1.5.2	Built-in and Direct Mounting System to CNC Spindle.....	9
1.5.3	Shaft Locking for Tool Clamping.....	9
1.5.4	Integrated Coolant Nozzle System.....	10
1.5.5	Tool Clamping.....	10
2	Installation	
2.1	Battery installation into the RPM wireless transmitter.....	11
2.2	Display.....	11
2.2.1	Prerequisite for display installation.....	11
2.2.2	Display Workspace Installation.....	11
2.2.3	Connect.....	12
2.2.4	Screens.....	12-17
2.2.5	Disconnect.....	17
2.3	HSM Jet Spindle.....	18
2.3.1	Prerequisites for the CNC Machine.....	18
2.3.2	Spindle Installation onto the CNC Machine.....	19
2.3.3	Placement of HSM Jet Spindle in Toolholder.....	19-20
2.3.4	Tool prerequisites.....	21
2.3.5	Tool Installation into the HSM Jet Spindle.....	21-22
2.3.6	Recommendations for tool clamping and cutting tool's run-out checking.....	23
3	Maintenance	
3.1	Periodic Maintenance.....	24
3.2	Change Battery on RPM Transmitter.....	24
3.3	Operation Conditions.....	24
3.4	Storage.....	24
3.4.1	Pre-Storage.....	24
3.4.2	Recommendations for tool clamping and cutting tool's run-out checking.....	24
4	Working with the HSM Jet Spindle	
4.1	Recalculating of the Table Feed for HSM Jet spindle.....	25-26
4.2	Tool Change.....	26
5	Troubleshooting	
5.1	Display messages.....	27
5.2	The HSM Jet Spindle shaft does not rotate or RPM does not correspond correctly to coolant pressure.....	27
5.3	The HSM Jet Spindle has not been used in the last month.....	27
6	Warranty Summary	28-29
7	Customer Service after Purchase	30
8	FCC Compliance Statement	31

Table of Figures

Figure 1: Spindle case content.....	5
Figure 2: Display case content.....	5
Figure 3: Rotation speed vs. tool diameter	6
Figure 4: The relation between coolant pressure & RPM value.....	6
Figure 5: HSM Jet Spindle wireless transmitter and display.....	6
Figure 6: Wireless RPM display main view	7
Figure 7: Wireless RPM display mounting options.....	7
Figure 8: HSM Jet Spindle with several mounting adaptation types.....	8
Figure 9: HSM Jet Spindle with pin mechanism locked	8
Figure 10: Integrated coolant nozzle system.....	9
Figure 11: Overhang solution types	9
Figure 12: Battery case open.....	10
Figure 13: Switch display ON.....	10
Figure 14: Many HSM Jet Spindles can be connected to one display	11
Figure 15: No signal displayed	11
Figure 16: Connection screens.....	12
Figure 17: Main display screen.....	12
Figure 18: List of connected HSM Jet Spindles display.....	13
Figure 19: Disconnection display.....	14
Figure 20: More than one device is working simultaneously screen.....	14
Figure 21: Disconnection list for multiple signals screens	14
Figure 22: Disconnect all sensors screens	15
Figure 23: Connection failed screen	15
Figure 24: Disconnection failed screen.....	16
Figure 25: Low battery screen	16
Figure 26: Low RPM screen.....	16
Figure 27: High RPM screen.....	17
Figure 28: HSM Jet Spindle on CNC machine	17
Figure 29: Placement of HSM Jet Spindle in toolholder steps.....	18
Figure 30: Example of a toolholder with a hole for coolant flow	19
Figure 31: HSM Jet Spindle holding with ER32 collet chuck.....	19
Figure 32: Inserting the WRENCH DIA3.2X45 into the HSM Jet Spindle.....	20
Figure 33: WRENCH DIA3.2X45 in HSM Jet Spindle.....	20
Figure 34: Loosening ER11 nut	21
Figure 35: Collet and tool in the HSM Jet Spindle	21
Figure 36: Tightening ER11 nut.....	21

1.1 Safety First

	<p>READ THE MANUAL</p> <p>Safety of the operator is a main concern. This equipment is as safe as we are able to make it. Avoid accidents by reading the safety alerts, investing a few seconds of thought and a careful approach to handling equipment. You, the operator, can avoid many accidents by observing the following precautions. Review the safety instructions of the manufacturer, supplier, owner, and all organizations responsible for the prevention of accidents.</p>
	<p>Ensure that:</p> <p>The work area and the area around the CNC machine are free of obstacles</p> <p>The work area is properly lit</p> <p>This equipment is operated only by a responsible adult trained in this operation</p> <p>This equipment is not operated by a person under the influence of drugs or alcohol</p> <p>This equipment is not operated by a person with any illness or physical condition that might reduce reflexes or awareness and increase exposure to risk.</p> <p>Before starting any kind of work, install all of the safety devices prescribed by the builder of the machine or power tool are in place</p> <p>Shaving/dust suction equipment must be used at the same time as the tool</p>
	<p>Warning: Rotating Tools, Entanglement Hazard</p> <p>To avoid risks associated with the use of rotating tools it is strongly recommended to use the utmost caution and concentration when working.</p>
	<p>Warning: Rotating Tools, Cut or Severe Hazard</p> <p>Always wear correctly sized gloves that allow the sensitivity necessary to operate the tool correctly and give adequate protection in the event of the blade being touched during use.</p>
	<p>Warning:</p> <p>Always use safety glasses or protective screens to protect your eyes.</p>
	<p>Install only tools in perfect condition that are recommended for the material to be worked and that are suitable for the type of machine used.</p> <p>Do not use cracked or deformed tools.</p> <p>Check that the balancing, keying and centering of rotary tools are carried out correctly</p> <p>Fix the tool correctly using the proper tightening and adjustment devices.</p> <p>Remove all tightening and adjustment devices before use.</p> <p>Check that the tool rotates in the correct direction.</p> <p>Never exceed the limits of a piece of machinery. If its ability to do a job, or to do so safely, is in question - DON'T TRY IT.</p>

1.2 Statement of Compliance

The HSM Jet Spindle meets the following standards.

1.2.1 European standards (CE)

- EMC: EN 301489-1/17
- Radio: EN 300328 V 1.8.1
- Safety: EN 61010-1:2010

1.2.2 American standards (UL)

- EMC: FCC Part 15 B
- Radio: FCC Part 15 C
- Safety: UL 61010-1

1.2.3 International standards

- Safety: IEC 61010-1:2010



DECLARATION OF CONFORMITY

We hereby declare that our product, the HSM jet spindle system, conforms to the applicable Safety, EMC & Radio requirements as specified in:

European standards (CE)

- EMC: EN 301489-1/17
- Radio: EN 300328 V 1.8.1
- Safety: EN 61010-1:2010

American standards (UL)

- EMC: FCC Part 15 B
- Radio: FCC Part 15 C
- Safety: UL 61010-1

International standards

- Safety: IEC 61010-1:2010

This declaration is only applicable when used in accordance with the intended purpose.



Dror Pockard, CEO



1.3 Introduction

The HSM Jet Spindle is a unique High Speed Machining (HSM) spindle (20 krpm, 30 krpm & 40 krpm).

It is driven by the CNC machine spindle coolant thru flow at minimum pressure of 20 bar.

The HSM Jet Spindle does not require any special installation aside from the installing it to the spindle.

It then operates like any other standard tool holder in the magazine.

1.4 Case Contents

The HSM Jet Spindle case includes:



Figure 1: Spindle case content

1. NUT ER11 GHS - this is a standard nut
2. WRENCH ER11 SMS - this is a standard wrench*
3. WRENCH DIA3.2x45 - this is a specialized shaft lock tool*
4. ALLEN KEY - Hexagonal 2.0 mm
5. BATTERY - Lithium Metal non-rechargeable, CR2 type

* Actual size and types of accessories may vary due to configuration and manufacturing process

The wireless RPM display case includes:



Figure 2: Display case content

1. TSD - this is wireless RPM display
2. Universal AC/5VDC power supply

* For USA/Japan: include EU to US/Japan AC adaptor plug



1.5 Main Features

The HSM Jet Spindle spindles are best used when high RPMs is required for small diameter tools on limited RPM CNC machines. The system utilizes the CNC machine tool's existing coolant supply driven by a high pressure pump (minimum 20 bar) as an energy source to rotate a turbine up to 40,000 RPM. The HSM Jet Spindle can be supplied either as right-hand or left-hand option.

The HSM Jet Spindle is not intended to replace the CNC machine spindle, but rather to upgrade the existing CNC machine, providing improved performance, faster machining, better surface quality, and extended tool life.

The new spindles can be used for semi-finish and finish machining applications such as milling, drilling, and jig grinding.

HSM Jet Spindle models operating ranges:

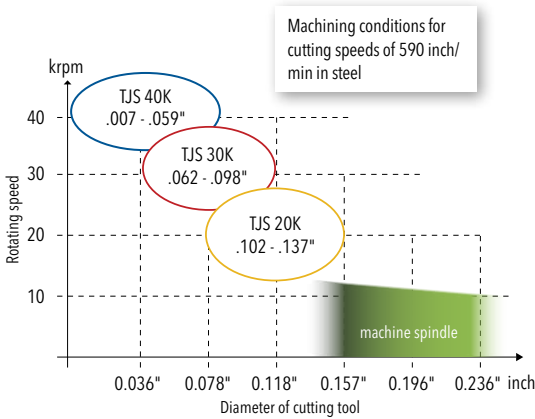

Figure 3: Rotation speed vs. tool diameter

HSM jet spindle type / RPM	Coolant pressure		
	20 bar	30 bar	40 bar
TJS 20K-ER32	20000* RPM	30000* RPM	40000* RPM
TJS 30K-ER32	30000* RPM	40000* RPM	50000* RPM

* approximate RPM values - depend on pressure, flow rate and used coolant type

Figure 4: The relation between coolant pressure & RPM value based on HSM jet spindle types

1.5.1 Wireless Rotation Speed Display general view:



Figure 5: HSM Jet Spindle wireless transmitter and display

The HSM Jet Spindle is equipped with an integrated wireless display system, allowing real-time monitoring of the rotating speed during machining.

This system consists of a transmitter installed on the spindle housing, and a receiver display.

The receiver is powered by a 5 VDC universal AC/DC power adaptor connected to either a 220 VAC or a 110 VAC power source.

The transmitter is powered by an exchangeable CR2 lithium battery.

Display information

Wireless display and RPM transmitter unit

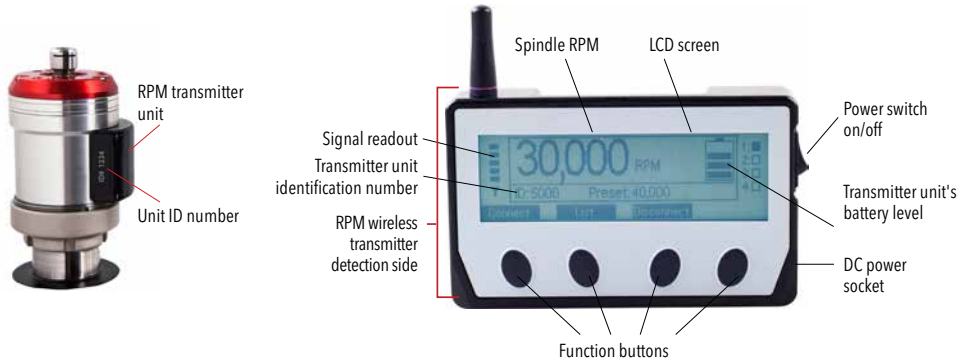

Figure 6: Wireless display and RPM transmitter unit main view

- 2.4 GHz radio frequency transmission
- Direct wireless rotational speed monitoring up to 16 feet range
- Externally powered a receiver display
- Enables reading of all HSM Jet Spindle systems being used on a specific CNC machine
This is limited to 127 tools
- Internally battery's powered RPM transmitter unit
- Own ID number for each RPM transmitter unit

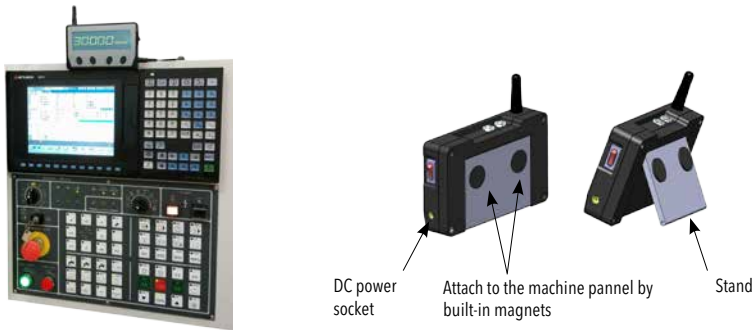
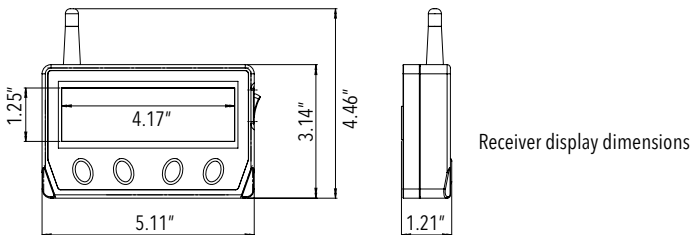

Figure 7: Wireless RPM display mounting options



1.5.2 Built-in and Direct Mounting System to CNC Spindle

HSM Jet Spindle is available in several mounting adaptation types:

- ER32 collet chuck with a special tightening nut, suitable for all standard tool holders with an ER32 adaptation - This is the default type.
- Integral options with various adaptations are available upon request.

Illustration purposes only



Figure 8: HSM Jet Spindle with several mounting adaptation types

HSM Jet Spindle with ER32 or ST20 mounting adaptations can be provided with filters upon request.

1.5.3 Shaft Locking for Tool Clamping

The shaft lock mechanism provides you with a simple and easy way to change the tool installed on your HSM Jet Spindle spindle. For instructions on installing the tool into the spindle see page 21.



Figure 9: HSM Jet Spindle with pin mechanism locked

	<p>Warning: Do not hold the pin handle while tightening/loosening the shaft lock mechanism. Failure to obey this warning might lead to a broken spindle shaft.</p>
	<p>It is strictly prohibited to use the HSM Jet spindle if shaft lock hole's protection plug is damaged or missing.</p>

1.5.4 Integrated Coolant Nozzle System

The Integrated coolant nozzle system provides 3 main advantages:

- Direct jet coolant application
- Better and faster chip evacuation
- Prevents tool thermal shock

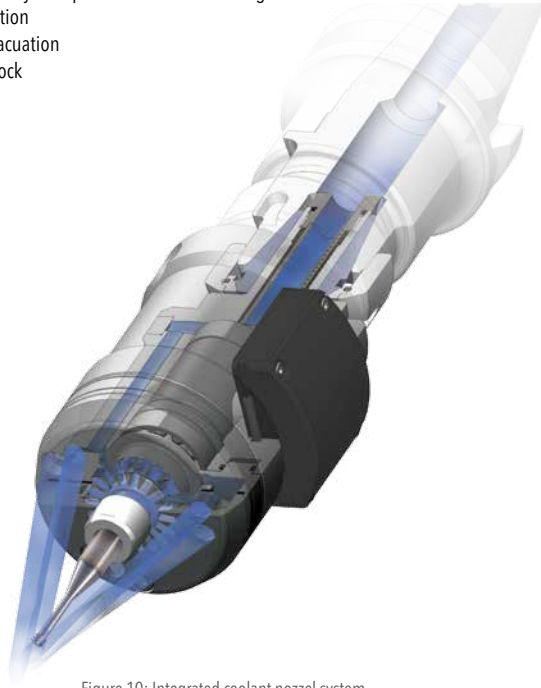

Figure 10: Integrated coolant nozzle system

1.5.5 Tool Clamping

The HSM Jet Spindle is compatible with ER11 collet chuck.

The assembly of rotating elements (collet, nut and tool) must be balanced to a G2.5 at 40,000 RPM.

We recommend that you use ER 11 high precision spring collets.

When longer overhang is required, 0.393" and 1.00" long ER11 thermal shrink collets are available.

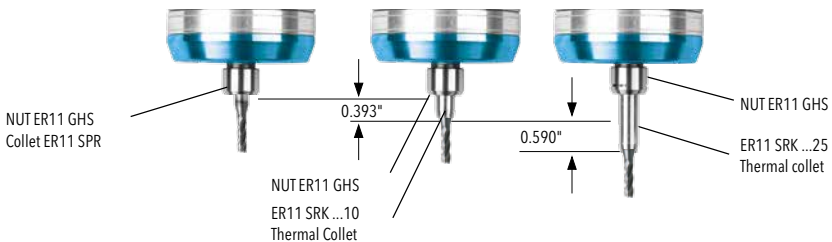

Figure 11: Overhang solutions types

2.1 Battery installation into the RPM wireless transmitter

To install the battery into the RPM transmitter:

1. Unscrew the 4 screws holding the battery case cover using a hexagonal 2 mm Allen key.
2. Remove the battery case cover.
3. Make sure the O-ring inside the cover is seated well, and intact.
4. Put in the CR2 lithium battery in correct direction
5. Return the battery case cover to its place.
6. Fasten the battery case cover with the 4 screws that were removed.

Now the transmitter is ready to work.

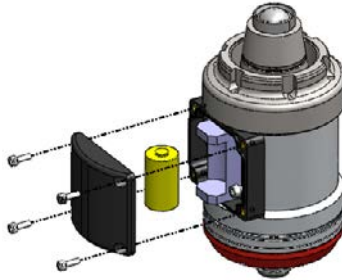

Figure 12: Battery case open

2.2 Display

The HSM Jet Spindle is equipped with an integrated wireless display system, allowing real-time monitoring of the rotating speed during machining.

2.2.1 Prerequisites for display installation

Make sure that the following pre-requisites are met:

1. Electrical power: 220/110 VAC, standard socket.
2. Distance from HSM Jet Spindle to Display: no more than 16 feet.
3. Available space for the display so that operator will have a close and unobstructed view of it.

2.2.2 Display Workspace Installation

1. Mount the display onto a metallic surface using the magnet on the back of the display, or place on a flat and leveled surface.
2. Connect the display to an AC socket.
3. Switch the display ON.

RPM wireless transmitter
detection side



2.2.3 Connect the HSM Jet Spindle to the display

The display and the HSM Jet Spindle must be connected (paired) so they can "identify" each other. Each transmitter unit has its own ID number (See Fig. 6)

To connect the HSM Jet Spindle to the display:

1. Make sure the display is ON.
2. Press CONNECT on the display panel.
3. Slide the transmitter (assembled on the HSM Jet spindle) along the left side of the display unit (RPM wireless transmitter detection side) in the direction shown in the picture:



Note: Connecting feature is the turning ON of the internal battery consumption on the transmitter unit. To save a battery energy and in case that HSM jet Spindle is not in use - do Disconnection procedure (see paragraph 2.2.5)

Figure 14: Many HSM Jet Spindles (not working simultaneously) can be connected to one display



2.2.4 Screens

When turned on NO SIGNAL / 0 RPM screen will appear.



Figure 15: No signal displayed

While connecting the HSM Jet Spindle you will see the CONNECTING displayed, then the "<device ID> CONNECTED - notice that the battery level of the HSM Jet Spindle is shown. Make sure that <device ID> on connected screen corresponds to the ID # signed onto the RPM transmitter unit.



Figure 16: Connection screens



The main display screen shows the HSM Jet Spindle that is working now. This shows the HSM Jet Spindle's ID number, rotation speed, and battery level.



Figure 17: Main display screen

2 INSTALLATION

You can see a list of all of the HSM Jet Spindles the display has been connected to, by pressing the "list" button.

Figure 18: List of connected HSM Jet Spindles display



Figure 19: Disconnection display



Note: Disconnecting feature is the turning OFF of the internal battery consumption on the transmitter unit.
If the display detects more than one HSM Jet Spindle working at any time, a "MULTIPLE SIGNAL" is shown (see Fig.20).

Figure 20: More than one device is working simultaneously screen



Select "List" to choose the device to disconnect from the next screen.



Figure 21: Disconnection list for multiple signals screen

The display can be cleared from all connected HSM Jet Spindles, or a list of previously connected devices can be viewed.



Figure 22: Disconnect all sensors screens



2 INSTALLATION

If the connect or disconnect processes don't succeed for any reason, an appropriate message is shown - see page 27 for troubleshooting.

Figure 23: Connection failed screen



Figure 24: Disconnection failed screen



If the battery of the HSM Jet Spindle you are currently using is running low - the following warning is shown - see page 27 for troubleshooting.

Figure 25: Low battery screen



If the HSM Jet Spindle is not spinning fast enough, the "LOW RPM" alert is shown.



Figure 26: Low RPM screen

If the HSM Jet Spindle is spinning too fast, the "HIGH RPM" alert is shown.



Figure 27: High RPM screen

2.2.5 Disconnect the HSM Jet Spindle from the display

1. Make sure the display is ON.
2. Press DISCONNECT on the display panel.
3. Slide the transmitter (assembled on the HSM Jet spindle) along the left side of the display unit (RPM wireless transmitter detection side) in the direction shown in the picture:

While disconnecting the HSM Jet Spindle you will see the "Disconnecting" screen.



"<device ID> disconnected screen" - notice that the battery level of the HSM Jet Spindle is shown. Make sure that <device ID> on disconnected screen corresponds to the ID # signed onto the RPM transmitter unit.

2.3 HSM Jet Spindle

2.3.1 Prerequisites for the CNC Machine

1. Coolant flow through the main CNC machine spindle
2. Minimum coolant pressure, at main machine spindle outlet: 20 bar
3. Maximum coolant pressure, at main machine spindle outlet: 40 bar
4. Minimum flow rate: 3.17 gallons/min
5. Minimum coolant filtration level: 100 µm
6. An active mist collector
7. With the emulsion coolant, use an anti-foaming agent additive suitable for your emulsion to prevent foaming.
8. Use emulsion coolant with oil percentage higher than 4%
9. With oil coolant, the high pressure increases the amount of oil fumes:
 - a. Use appropriate means of fire protection and extinguishing.
 - b. Use anti-dissolution additive suitable for your oil.

2.3.2 HSM Jet Spindle Installation onto the CNC Machine

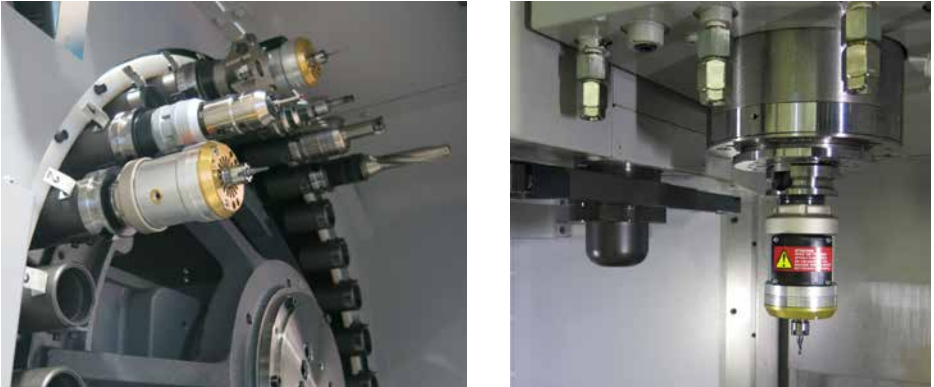

Figure 28: HSM Jet Spindle on CNC machine

While the HSM Jet Spindle is mounted on the machine, the CNC machine spindle should be stationary, except for tool checking procedure or Z-offset measurement. In those cases it must not exceed 3000 RPM, or risk breaking/injury. To avoid the CNC machine spindle rotation during the HSM Jet Spindle operation use the correct software M-code to lock the Spindle orientation.

For example: "M19" code stops the spindle in a defined angle position.

Before installing a HSM Jet Spindle with a filter on the machine spindle, make sure that the filter is clean.

2.3.3 Placement of HSM Jet Spindle in the Toolholder

Caution: Deviation from these steps might lead to locking of the tightening nut to the HSM Jet Spindle. The HSM Jet Spindle will only work with a toolholder that has a coolant through channel.

To fix the HSM Jet Spindle in a toolholder: See steps from left to right in Figure 29.



1. Use a standard tool holder with ER32 collet chuck
2. Loosen the HSM Jet Spindle tightening nut 1.5 full turns
3. Insert built-in ER32 taper shank into ER32 collet chuck until the HSM Jet Spindle tightening nut will be placed on the toolholder
4. Fasten the HSM Jet Spindle tightening nut onto the toolholder, without turning the HSM Jet Spindle relative to the nut
5. Fasten the HSM Jet Spindle tightening nut to clamp the HSM Jet Spindle and the toolholder together with an ER 32 spanner, use hand force only

Figure 29: Placement of HSM Jet Spindle in toolholder steps



Figure 30: Example of a toolholder with a hole for coolant flow

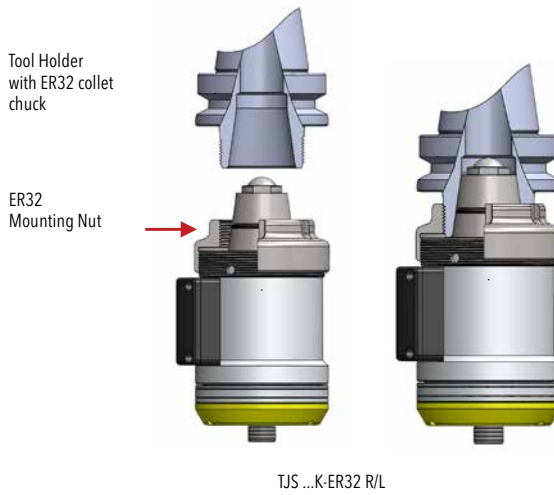

Figure 31: HSM Jet Spindle holding with ER32 collet chuck

2.3.4 Tool prerequisites

HSM Jet Spindle spindles are for applications requiring tool shanks of up to 6 mm.

Application	Maximum tool working diameter, Ø [mm]
Milling	Slotting: $ae \leq 0.118"$ & $ap = 0.1 D$ Shouldering: $\text{Ø}D \leq 0.137"$, $ae = 1 D$ & $ap = 0.25 D$
Drilling	Max. Ø 0.078"
Jig grinding	Max. Ø 0.393"
Thread milling	Max. M5 (ISO), RH or LH rotation, solid carbide
Chamfering & engraving	Up to 0.236" tool shank.

2.3.5 Tool Installation into the HSM Jet Spindle

The HSM Jet Spindle can hold various tools that use an ER11 collet.

To set a tool into the HSM Jet Spindle

1. Insert the WRENCH DIA3.2X45 in the shaft lock hole, on the side of the spindle.



Figure 32: Inserting the WRENCH DIA3.2X45 into the HSM Jet Spindle

2. Turn the shaft, while pushing the WRENCH DIA3.2X45 in, toward the center of the HSM Jet Spindle, until the WRENCH DIA3.2X45 handle reaches the HSM Jet Spindle.



Figure 33: WRENCH DIA3.2X45 in HSM Jet Spindle



Warning:

Do Not hold the WRENCH DIA3.2X45 (shaft lock pin) handle while tightening/loosening the ER11 nut. Failure to obey this warning might lead to a broken spindle shaft.

3. Loosen the ER11 nut with the provided ER11 wrench, and remove the nut.



Figure 34: Loosening ER11 nut



Figure 35: Collet and tool in the HSM Jet Spindle

4. Insert the tool into the collet.
5. Place the collet in the spindle.

6. Tighten the ER11 nut with the provided ER11 wrench.
7. Check that total runout is less than 0.0003".



Figure 36: Tightening ER11 nut

2.3.6 Recommendations for tool clamping and cutting tool's run-out checking

The HSM Jet spindle is very precision product, designed for high speed machining with a small diameter cutting tools for the accurate machining.

We attached great importance to the cutting tool's setup, correct clamping procedure and tool's run-out checking.

On the HSM Jet spindle we use a standard clamping tools, as ER11 spring collets and standard clamping accessories.

To get a minimum run-out value we propose the using a precised spring collects with exact hole size.

According to ISO 15488 the collet run-out tolerances should be checked as shown at the sketch below.

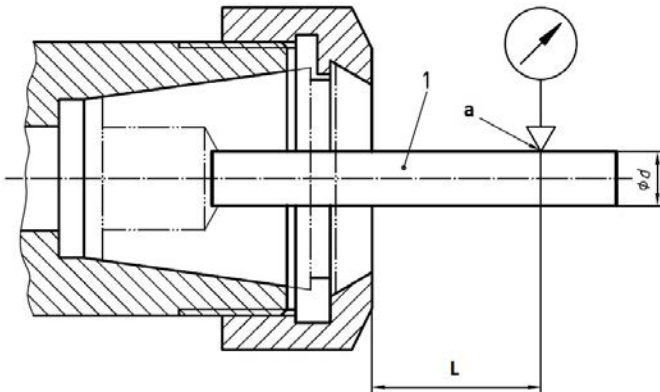

1 - test mandrel

a - test point

Figure 36: Testing of run-out tolerance

For tool shank diameter from 0.118" up to 0.236" the distance "L" - run-out measure gauge placement - should be 0.629". Allowed run-out tolerance at this measuring point on the test mandrel is up to 0.00003".

The diameter of the test mandrel is the nominal diameter of the collet hole.

For the test mandrel, the following specifications apply:

- a) diameter tolerance: h6
- b) cylindricity: 0.00007"
- c) parallelism :0.00007"
- d) roundness: 0.00007"
- e) surface without longitudinal marks
- f) maximum surface roughness Rz = 4 μm
- g) surface hardness: (about 58 HRc)

The recommended torque for ER11 nut is 8-10 Nm.

The maximum torque for clamping nut shall not be more than 25% above the recommended tightening torque.

Higher tightening torque may result in the deformation of the toolholder (ER11 seat).

Higher clamping force of the clamping nut at the same time means higher stress on the toolholder (ER11 seat).



3.1 Periodic Maintenance

The HSM Jet Spindle is free of periodic maintenance.

3.2 Change Battery on RPM Transmitter

The battery in the RPM transmitter mounted on your HSM Jet Spindle will be drained over time.

To change the battery please make procedure as in chapter 2 (Installation p. 10)

3.3 Operation Conditions

- Operation temperature range: 59 °F to 80 °F
- Altitude: 6,562 feet

3.4 Storage

3.4.1 Pre-Storage

Before storing the HSM Jet Spindle:

- Clean the HSM Jet Spindle with an air blow for 10-15 sec.
- Disconnect the HSM Jet Spindle from the display that it is connected to.
- Place the HSM Jet Spindle in its case.

3.4.2 Conditions

The HSM Jet Spindle must be stored in conditions meeting the following requirements:

- Sheltered from possible adverse weather conditions.
- Ideal Storage Temperature Range: 59 °F to 80 °F.
- Humidity Range: 30% to 60% relative humidity (RH)



Warning:

It is strictly prohibited immerse the HSM Jet Spindle in a fluid bath.

It is strictly prohibited to use the cleanser, different from the coolant, allowed for using on HSM Jet Spindle.

Any damage caused by one of the above "Warnings" will not be covered by limited warranty

The HSM Jet spindle system was developed to create machining conditions that would enable applying optimal cutting speed conditions for small diameter solid carbide tools requiring high RPM.

The HSM Jet spindle rotates at its rated speed when idle. When the cutting tool enters the workpiece, it is expected that the rotation speed might slow down by several thousand RPM.

If the HSM Jet spindle rotation speed drops by more than several thousand RPM, when the cutting tool enters the workpiece, review the cutting process parameters and adjust them accordingly.

HSM Jet Spindles types vs. Cutting tool diameter:

HSM Jet spindle type	TJS 20K...	TJS 30K...	TJS 40K...*
Cutting tool diameter [inch]	0.185" - 0.137"	0.039" - 0.098"	0.007" - 0.059"
Spindle speed krpm]**	20	30	40
Recommended cutting speed [f/min]	for steel ≤ 656		
	for aluminum ≥ 656		

* in development

** based on coolant pressure 20 bar & flow rate 3.17 g/min

In order to use the advantages of high speed machining, minimize cutting forces and reduce wear, tool diameter should be selected according to the spindle speed (when possible).

- Always select the smallest tool diameter, according to the application requirements.
- Always select cutting tools in grades that are suitable for high speed machining.

4.1 Recalculating of the Table Feed for HSM Jet spindle

There are two calculating methods of table feed F [inch / min], operating with the HSM Jet spindle:

- Existing machining process (transition from machining with a machine spindle to an HSM Jet spindle)
- In case of selecting a new machining process

4.1.1 Existing machining process:

The feed per tooth f_z remains constant while the table feed F increases in the same proportion to the HSM Jet Spindle rotation speed.

The feed per tooth f_z should remain constant while the table feed F is changed.

Calculate the table feed F [inch/min] according to the following formula:

$$F \approx \text{Ratio} \times F_{\text{current}}$$

F - the new table feed.

Ratio - Is the ratio between the machine spindle speed and HSM Jet spindle speed, meaning the new speed divided by the current speed.

F_{current} - the current table feed that you would use with your machine.

4 WORKING WITH THE HSM Jet Spindle

For example:

If using machine spindle at 8,000 RPM, and the table feed was 6 IPM, and you set HSM Jet spindle to 30,000 RPM, then we suggest that your new table feed be:

New table feed = $30,000/8,000 \times 160 = 3.75 \times 6$ IPM.

In this example your new table feed should be 23.62 IPM.

4.1.2 New machining process

Calculate the table speed F [inch/min] according to the formula:

$$F = n \times z \times fz$$

Rotating speed - n [RPM] The rotating speed for table speed calculation will be determined only after reading the actual rotation speed obtained when the tool has engaged the material.

Number of teeth - z

Feed per tooth - fz [inch/tooth] - Select according to the tool's vendor recommendations, taking into consideration the machining material, the application and the tool geometry.

Note:

For the first trial at both machining processes, it is recommended to increase the table feed gradually by of 0.118" - 0.137" (not directly 0.137"), before setting the table feed to the above calculated value.

5.1 Display messages

Display message	Indicates that	Action required
NO SIGNAL	No connected HSM Jet Spindle working in range	If no HSM Jet Spindle is currently at work - no action required If a HSM Jet Spindle is working - wait 10 sec. If message persists disconnect and then reconnect it.
MULTIPLE SIGNAL	More than one device is working at once	Press LIST button, then disconnect one of the HSM Jet Spindle
LOW RPM	HSM Jet Spindle is spinning too slow	Check: HSM Jet Spindle, coolant pressure, and cutting parameters
HIGH RPM	HSM Jet Spindle is spinning too fast	Check: HSM Jet Spindle, and coolant pressure
FAILED TO CONNECT	Connection did not succeed	Retry the connection process. Still not working? Replace the HSM Jet Spindle battery.
FAILED TO DISCONNECT	Disconnection did not succeed	Retry the disconnection process. Still not working? Replace the HSM Jet Spindle battery.
LOW BATTERY	Battery is low on power	Replace the battery

5.2 The HSM Jet Spindle shaft is not rotate or RPM does not correspond correctly to coolant pressure (may result in "low RPM" message)

1. Check coolant and pressure in cooling system.
2. Run coolant through HSM Jet Spindle for 5 min. while idle.
3. If issue persists - call for technical assistance.

5.3 The HSM Jet Spindle has not been used in the last month

Before working with the HSM Jet Spindle that has not been used recently, run coolant through the HSM Jet Spindle, when it is assembled on your CNC machine, for 3 to 5 min. Make sure that the HSM Jet Spindle reaches a speed that corresponds to the pressure of the coolant that is pumped through it.

LIMITED WARRANTY FOR HSM JET SPINDLE

1. This Limited Warranty ("Warranty") is given by Ingersoll Cutting Tools, with registered office at 845 S. Lyford Rd., Rockford, IL 61108, operating through its designated affiliates and/or parties authorized by it in writing (hereinafter, all collectively and each severally - "Ingersoll"), as dealer of the spindle for CNC machines known as TYPHOON (the "Product"), to the customer contracting Ingersoll in respect of the Product ("Customer").
This Warranty shall apply, on the terms specified herein, to any contract, including, but not limited to, contracts of sale, lease, license, placement or services, the subject matter of which is the provision of the Product by Ingersoll to Customer, unless otherwise specifically agreed in writing between the said parties.
2. Ingersoll warrants the Product to be free of defects in material and workmanship and to conform to the applicable Ingersoll's specifications, for a period of 12 months commencing on the date of delivery of the Product to Customer (the "Warranty Period"), subject to normal use, storage and application thereof in accordance with and based on Ingersoll's standard tolerances, instructions of use and recommendations and conform to the applicable specifications provided by Ingersoll. Apparent defects shall be reported to Ingersoll in writing within 3 working days as of the Customer's receipt of the Product. Latent defects occurring within the Warranty Period shall be reported in writing within 3 working days as of discovery.
3. During the Warranty Period, Ingersoll shall, at its option and sole discretion, either repair, replace, or grant credit for, any Product and any component thereof, which are determined by it to be defective pursuant to Section 2 above, at no additional charge to the Customer, and subject to the entire terms and conditions set forth herein.
4. This Warranty does NOT cover any damage resulting from extraneous causes not attributable to Ingersoll including, inter alia, accident or disaster, misuse, abuse, neglect or improper maintenance, modification or alteration, or attempted unauthorized dismantling and/or repairs by the Customer or any third party, wear or damage resulting from corrosion or processing of abrasive/aggressive resins, damages resulting from operation of the product not within the working parameters and working environment it was designed for, damages resulting from Customer's non-compliance with applicable laws, regulations, or by-laws, and standard industry practices, as well as any other damage sustained due to causes beyond the reasonable control of Ingersoll.
5. This Warranty shall not apply in the event the Customer fails to pay for the Product in full and/or on a timely basis as set out in any sale, license, lease, placement, or services agreement, or any other legal instrument which has been executed by Ingersoll and the Customer, including, without limitation, invoices issued by Ingersoll or its local authorized agent to Customer from time to time.
6. Warranty service may be obtained by returning the defective Product or any component thereof during the Warranty Period to Ingersoll with proof of purchase and date of delivery. Any and all repairs shall be carried out, and this Warranty shall accordingly cover only such repairs, at the premises of Ingersoll and/or its local authorized agent and/or supplier. However, Ingersoll strongly recommends that the Customer obtains preliminary support from Ingersoll by e-mail and/or telephone prior to returning the Product to Ingersoll.
7. In case Customer desires to exercise its right under this Warranty, the Customer shall, at they own and exclusive expense, place the Product at Ingersoll's premises for inspection, and repair or replacement, if necessary. The Customer shall bear all costs associated with the transportation of the Product from the Customer's premises to Ingersoll's premises and back to Customer's premises once inspection and where required - repair or replacement, have been performed by Ingersoll.
8. Ingersoll retains the right to examine and inspect the Product once received from the Customer in order to determine, inter alia, the cause of the alleged defect, and whether this Warranty applies.
9. Replacement parts shall be furnished on an exchange basis and may be either reconditioned or new. All defective parts which were replaced hereunder shall become the property of Ingersoll.
10. THIS WARRANTY IS THE ONLY WARRANTY OFFERED BY Ingersoll AND IS IN LIEU OF ANY IMPLIED WARRANTIES, INCLUDING BUT NOT LIMITED TO, WARRANTY OF MERCHANTABILITY AND FITNESS FOR A PARTICULAR USE OR PURPOSE, ANY AND ALL OF WHICH ARE HEREBY EXPRESSLY DISCLAIMED, DENIED AND EXCLUDED.
BY BUYING THE PRODUCT THE CUSTOMER AGREES AND ACKNOWLEDGES THAT THE REMEDY AVAILABLE TO HIM AS

SPECIFIED HEREIN, IS IN LIEU OF ANY REMEDIES THAT MAY BE OTHERWISE AVAILABLE TO HIM, NOW OR IN THE FUTURE, WHETHER IN LAW OR IN EQUITY.

ANYTHING STATED HEREIN TO THE CONTRARY NOTWITHSTANDING, IN NO EVENT WILL Ingersoll BE LIABLE FOR ANY SPECIAL, PUNITIVE, INCIDENTAL, EXEMPLARY OR CONSEQUENTIAL DAMAGES (INCLUDING, BUT NOT LIMITED TO, LOSS OF ANY PROFIT, BUSINESS, PRODUCTION OR REVENUE), NOR FOR INJURY TO PROPERTY, ARISING OUT OF THE USE, MISUSE OR INABILITY TO USE THE PRODUCT, EVEN IF Ingersoll HAS BEEN ADVISED OF THE POSSIBILITY OF SUCH DAMAGES OR LOSSES, OR FOR ANY CLAIM BY ANY OTHER PARTY.

11. This Warranty, including any and all undertakings, guarantees or assurances provided herein by Ingersoll, is specifically limited to the Customer, and not imputed by Ingersoll, whether directly or indirectly, expressly or impliedly, to any other person or entity, including any subsequent buyer or user, bailee, licensee, assignee, employee, or agent of Customer.
12. Your statutory rights are and shall remain unaffected by this Limited Warranty, all terms and conditions of this Warranty are subject to the relevant law applicable in the jurisdiction in which the Product was purchased, unless otherwise agreed by the parties in writing. If any provision hereof is declared by any competent legal authority to be invalid or unenforceable for any reason under applicable law, then such provision shall be reformed to the extent necessary to make it valid and enforceable under that law. Every provision hereinabove is intended to be severable and, if any term or provision hereof is determined to be illegal, invalid or unenforceable for any reason whatsoever and cannot be reformed so as to be legal, valid and enforceable, such provision shall be deemed severed herefrom and the illegality, invalidity or unenforceability of such provision shall not affect the legality, validity and enforceability of the remainder of this Limited Warranty.

7 Customer Service after Purchase

Whenever a malfunction cannot be solved by the solutions mentioned in the troubleshooting section, you are requested to consult the Ingersoll representative for further assistance or instructions.

The unit should not be returned before receiving written approval from Ingersoll. The serial number for the unit must be indicated on your claim form (you can find this information on the rear of the unit housing).

We hope this information will be helpful. Our goal is to provide the best possible service to our customers.

This device has been tested and found to comply with the limits for a Class A digital device, pursuant to Part 15 of the FCC Rules. These limits are designed to provide reasonable protection against harmful interference in residential installations. This equipment generates uses and can radiate radio frequency energy and, if not installed and used in accordance with the instructions, may cause harmful interference to radio and television reception.

However, there is no guarantee that interference will not occur in a particular installation. If this device does cause such interference, which can be verified by turning the device off and on, the user is encouraged to eliminate the interference by one or more of the following measures:

- Re-orient or re-locate the receiving antenna.
- Increase the distance between the device and the receiver.
- Connect the device to an outlet on a circuit different from the one that supplies power to the receiver.
- Consult the dealer or an experienced radio/TV technician.

	<p>Warning: Changes or modifications to this unit not expressly approved by the party responsible for compliance could void the user's authority to operate the equipment.</p>
---	---

This device complies with FCC Rules Part 15: Operation is subject to two conditions: (1) This device may not cause harmful interference, and (2) this device must accept any interference that may be received or that may cause undesired operation.

To comply with FCC Section 1.310 for human exposure to radio frequency electromagnetic fields, implement the following instruction:

A distance of at least 7.87 inches between the equipment and all persons should be maintained during the operation of the equipment.

Member IMC Group
Ingersoll
Cutting Tools



Typhoon
HSM Jet Spindles

2909536 MAN-012 (10/14)