

COMPLETE SWISS TOOLS PRICING

TOOLS FOR CITIZEN, GANESH, HANWHA, NEXTURN,
NOMURA, STAR, SWISTEK, TORNOS AND TSUGAMI



20 Thompson Rd | East Windsor | CT 06088
1.800.249.5662 | 860.623.4132 Fax
www.komaprecision.com | info@komaprecision.com

KOMA PRECISION has the **FINEST** the world has to offer in machine tool Productivity Innovation

KOMA Precision is the foremost source for the finest the world has to offer in machine tool Productivity Innovation. For over 30 years Koma has been providing superior service and knowledge to match machine with client.

Our 25,000 sq. ft. facility features a completely equipped machine shop, state of the art inspection equipment, a product demonstration showroom, and a multi-million dollar new product and spare parts inventory.



TABLE OF CONTENTS



TABLE OF CONTENTS

Citizen	4
Ganesh	9
Hanwha	12
Nexturn	14
Nomura	15
Star	16
Swistek	22
Tornos	24
Tsugami	26
Tools	28

A20VII TOOLING FOR GANG TOOL POST

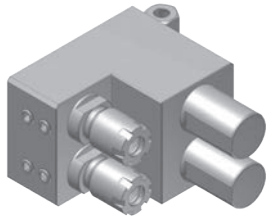

CTA162000
2 tool deep hole drill holder

TOOL SHANK Ø25.4mm
TOOL CLAMPING ER16M
DRILLING DEPTH(MAX) 95mm
MACHINE A20/A32
PRICE: \$1,100.00

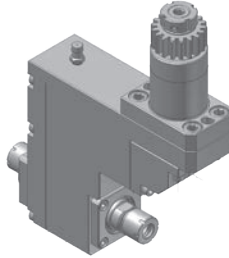

CTA511000
1 spindle drilling/milling unit

RATIO 1 : 1
RPM(MAX) 6000
TOOL CLAMPING ER11M
CITIZEN ITEM NO. BSE1007
PRICE: \$4,850.00

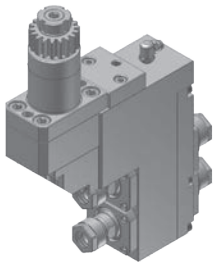

CTA541200
2 spindle drilling/milling unit

RATIO 1 : 1
RPM(MAX) 6000
TOOL CLAMPING ER11A
CITIZEN ITEM NO. BSE2007
PRICE: \$6,450.00

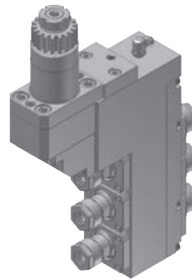

CTA541300
3 spindle drilling/milling unit

RATIO 1 : 1
RPM(MAX) 6000
TOOL CLAMPING:
Front Side: ER16
Back Side: ER11A
CITIZEN ITEM NO. BSE507
PRICE: \$6,850.00

B12 TOOLING FOR GANG TOOL POST

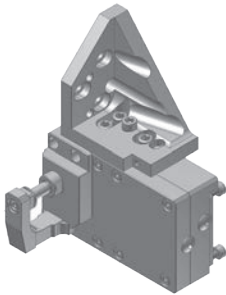

CTB801000
Gear hobbing unit

RATIO 2 : 1
RPM(MAX) 7000
CUTTER OD(MAX) Ø30.0mm
CUTTER SHANK Ø8.0mm
PRICE: \$4,250.00

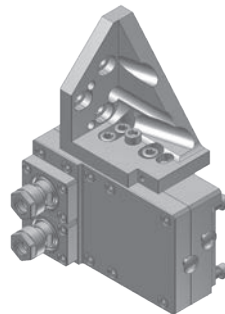

CTB812000
2 spindle cross drilling/milling unit

RATIO 2 : 1
RPM(MAX) 7000
TOOL CLAMPING ER11A
PRICE: \$5,250.00

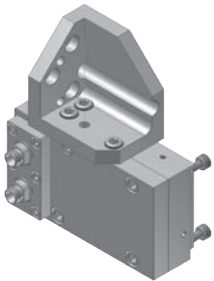

CTB882000
2 spindle cross drilling/milling unit

RATIO 2 : 1
RPM(MAX) 7000
TOOL CLAMPING ER8
CITIZEN ITEM NO. B12431B
PRICE: \$5,250.00

C16/M12/M16 TOOLING FOR GANG TOOL POST

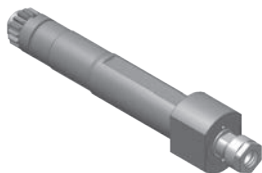

CTC161100
Cross drilling/milling unit

RATIO 1 : 1
RPM(MAX) 8000
TOOL CLAMPING ER11A
CITIZEN ITEM NO. GSC607
PRICE: \$1,625.00

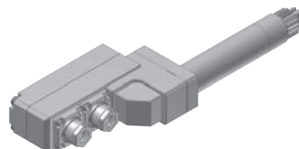

CTC441200
2 spindle drilling/milling unit

RATIO 1 : 1
RPM(MAX) 6000
TOOL CLAMPING ER11A
PRICE: \$6,200.00

M16 TOOLING FOR TURRET TOOL POST

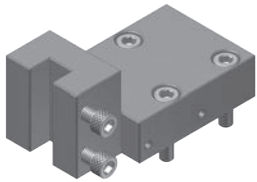

CTM1601101100
Turning bite holder

BITE HOLDER SHANK
10x10mm
CITIZEN ITEM NO. VTF110
PRICE: \$825.00

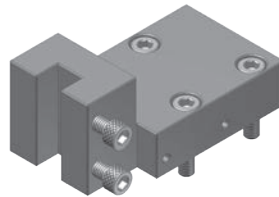

CTM1602101100
Turning bite holder

BITE HOLDER SHANK
10x10mm
CITIZEN ITEM NO. VTF1310
PRICE: \$825.00

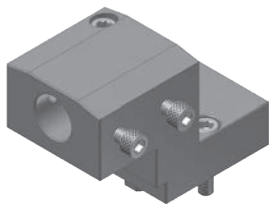

CTM1603192100
1 tool boring bar holder

BORING BAR SHANK
Ø19.05mm
CITIZEN ITEM NO. VDF201
PRICE: \$825.00



CTM1603192100-1
1 tool boring bar holder

BORING BAR SHANK
Ø19.05mm
CITIZEN ITEM NO. VDF501
PRICE: \$825.00

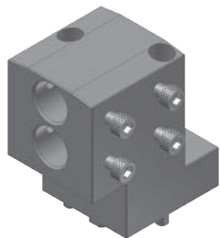

CTM1603192200
2 tool boring bar holder

BORING BAR SHANK
Ø19.05mm
CITIZEN ITEM NO. VDF401
PRICE: \$950.00



CTM1605111100-1
Cross drilling/milling unit

RATIO: 1/1
RPM: 6,000
TOOL CLAMPING: ER11A
MACHINE: M12/M16
CITIZEN ITEM NO. MSC107BT
PRICE: \$2,950.00

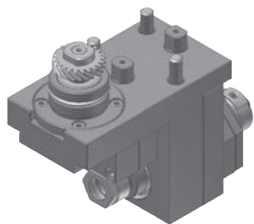

CTM1603112100
1 spindle drilling/milling unit

RATIO 1 : 1
RPM(MAX) 6000
TOOL CLAMPING ER11A
CITIZEN ITEM NO. MST306
PRICE: \$5,550.00

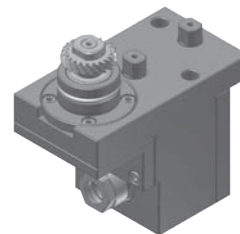

CTM1604112100
1 spindle drilling/milling unit

RATIO 1 : 1
RPM(MAX) 6000
TOOL CLAMPING ER11A
CITIZEN ITEM NO. MSE106
PRICE: \$4,925.00

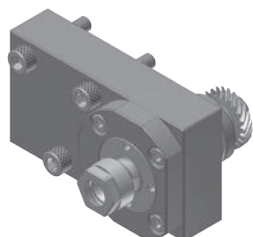

CTM1605111100
Cross drilling/milling unit

RATIO 1 : 1
RPM(MAX) 6000
TOOL CLAMPING ER11A
CITIZEN ITEM NO. MSC106
PRICE: \$2,775.00

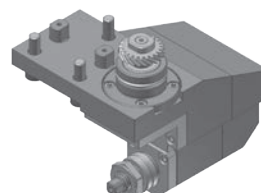

CTM1606122100
Slotting unit

RATIO 1 : 1
RPM(MAX) 4000
SAW OD(MAX) Ø45mm
SA ARBOR SHANK Ø12.7mm
CITIZEN ITEM NO. MSS345
PRICE: \$5,550.00

L16/L20 TOOLING FOR GANG TOOL POST

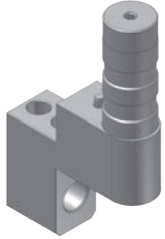

CTL101190 / CTL101191
1 tool sleeve holder

TOOL SHANK Ø32mm
DRILL SLEEVE SHANK
CTL101190 : Ø19.05mm
CTL101191 : Ø20.0mm
CITIZEN ITEM NO. GDF506
PRICE: \$975.00

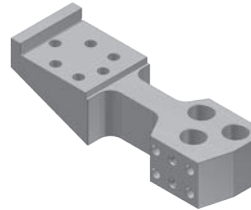

CTL103001
3 tool sleeve holder

DRILL SLEEVE SHANK
Ø19.05mm
CITIZEN ITEM NO. GDF607
PRICE: \$1,200.00

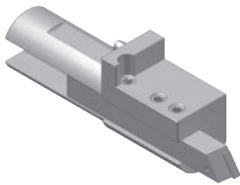

CTL2012100
Turning tool holder

TOOL SHANK Ø32mm
BITE HOLDER SHANK 12x12mm
PRICE: \$350.00

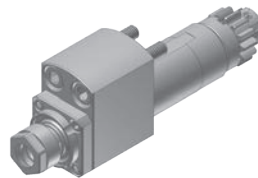

CTL111000
Cross drilling/milling unit

RATIO 1 : 1
RPM(MAX) 6000
TOOL CLAMPING ER11A
CITIZEN ITEM NO. GSC907
PRICE: \$1,625.00



CTL161000
Cross drilling/milling unit

RATIO 1 : 1
RPM(MAX) 8000
TOOL CLAMPING ER16A
CITIZEN ITEM NO. GSC510
PRICE: \$1,625.00

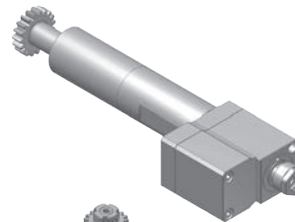

CTL161100
Cross drilling/milling unit

RATIO 1 : 3
RPM(MAX) 15000
TOOL CLAMPING ER11A
CITIZEN ITEM NO. GSC510-3X
PRICE: \$3,400.00



CTL411000
1 spindle drilling/milling unit

RATIO 1 : 1
RPM(MAX) 6000
TOOL CLAMPING ER11M
CITIZEN ITEM NO. GSE107
PRICE: \$5,425.00

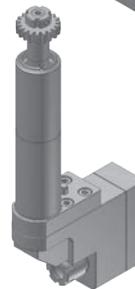

CTL461000
1 spindle drilling/milling unit

RATIO 1 : 1
RPM(MAX) 6000
TOOL CLAMPING ER16M
PRICE: \$5,425.00

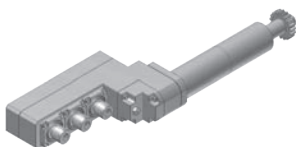

CTL441300
3 spindle drilling/milling unit

RATIO 1 : 1
RPM(MAX) 8000
TOOL CLAMPING ER11M
PRICE: \$6,450.00

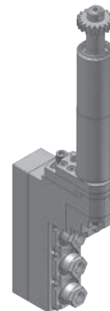

CTL491300
3 spindle drilling/milling unit

RATIO 1 : 1
RPM(MAX) 6000
TOOL CLAMPING ER11A
ANGLE ADJUSTMENT ±15°
CITIZEN ITEM NO. GSA107
PRICE: \$6,425.00

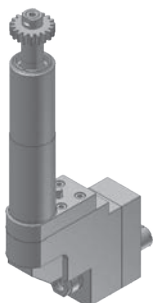

CTL511000
1 spindle drilling/milling unit

RATIO 1 : 1
RPM(MAX) 6000
TOOL CLAMPING
Front side : ER11A
Back side : ER11M
PRICE: \$5,825.00

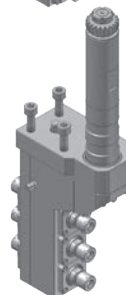

CTL513000-1
3 spindle drilling/milling unit

RATIO 1 : 1
RPM(MAX) 5000
TOOL CLAMPING ER11M
CITIZEN ITEM NO. GSE1307
PRICE: \$10,100.00

L20E/L20X TOOLING FOR GANG TOOL POST

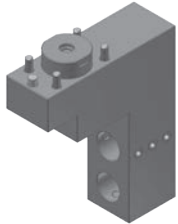

CTL140200-1
2 tool sleeve holder

TOOL SHANK Ø31mm
DRILL SLEEVE SHANK
Ø19.05mm
CITIZEN ITEM NO. GDF508
PRICE: \$900.00

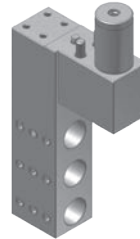

CTL140300-3
3 tool sleeve holder

TOOL SHANK Ø25mm
DRILL SLEEVE SHANK
Ø19.05mm
CITIZEN ITEM NO. GDF507
PRICE: \$975.00

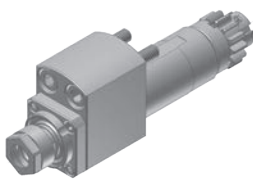

CTL111000
Cross drilling/milling unit

RATIO 1 : 1
RPM(MAX) 6000
TOOL CLAMPING ER11A
CITIZEN ITEM NO. GSC907
PRICE: \$1,625.00

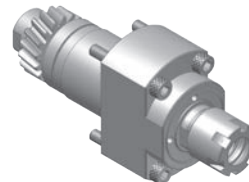

CTL861000
Cross drilling/milling unit

RATIO 1 : 1
RPM(MAX) 8000
TOOL CLAMPING ER16M
CITIZEN ITEM NO. GSC1210
PRICE: \$1,300.00



CTL161000
Cross drilling/milling unit

RATIO 1 : 1
RPM(MAX) 8000
TOOL CLAMPING ER16A
CITIZEN ITEM NO. GSC510
PRICE: \$1,625.00

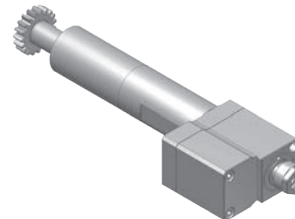

CTL161100
Cross drilling/milling unit

RATIO 1 : 3
RPM(MAX) 15000
TOOL CLAMPING ER11A
CITIZEN ITEM NO. GSC510-3X
PRICE: \$3,400.00

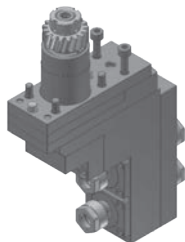

CTL541200
2 spindle drilling/milling unit

RATIO 1 : 1
RPM(MAX) 6000
TOOL CLAMPING ER11A
CITIZEN ITEM NO. GSE3107
PRICE: \$6,050.00

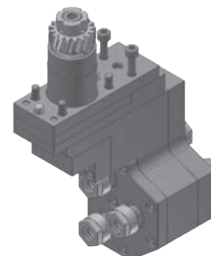

CTL541300-2
3 spindle drilling/milling unit

RATIO 1 : 1
RPM(MAX) 6000
TOOL CLAMPING ER11A
CITIZEN ITEM NO. GSE3207
PRICE: \$6,450.00

L20E/L20X TOOLING FOR BACK TOOL POST

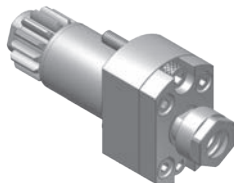

CTL711000
Drilling/milling unit

RATIO 1 : 1
RPM(MAX) 8000
TOOL CLAMPING ER11A
CITIZEN ITEM NO. GSE3507
PRICE: \$1,300.00

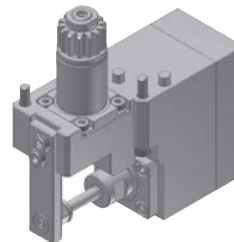

CTL731000
Slotting unit

RATIO 1 : 1
RPM(MAX) 4000
SAW OD(MAX) Ø35mm
SAW ARBOR SHANK Ø6.0mm
CITIZEN ITEM NO. GSS1330
PRICE: \$4,450.00

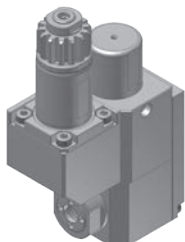

CTL761100E
Cross drilling/milling unit

RATIO 1 : 1
RPM(MAX) 6000
TOOL CLAMPING ER11
MACHINE L20E
CITIZEN ITEM NO. GSS1330
PRICE: \$4,200.00

L20/L32 AIR TOOL AIR TOOL HOLDER

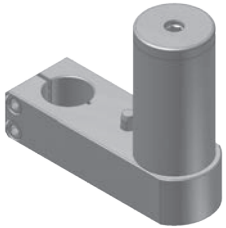

CTL401000
Air tool holder

TOOL SHANK Ø32.0mm
AIR TOOL SHANK
Ø19.05/20.0mm
PRICE: \$475.00

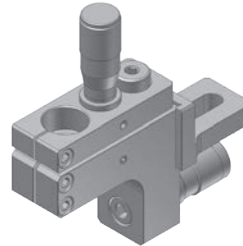

CTL601000
Air tool holder

TOOL SHANK
Ø19.05/20.0/25.4mm
AIR TOOL SHANK
Ø19.05/20.0mm
PRICE: \$700.00

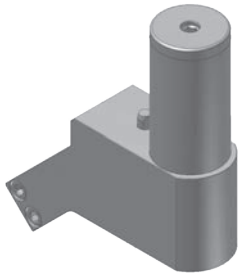

CTL4014500
Air tool holder

TOOL SHANK Ø32.0mm
AIR TOOL SHANK Ø19.05mm
TILT ANGLE 45°
MACHINE L32
PRICE: \$1,700.00

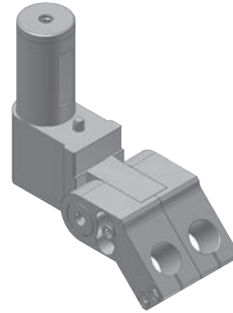

CTL4101200
Air tool holder

TOOL SHANK Ø32.0mm
AIR TOOL SHANK Ø12.0mm
TILT ANGLE 45°
ANGLE ADJUSTMENT ±20°
PRICE: \$2,050.00

M32



CTM3204161100-1
Cross drilling/milling unit

RATIO: 2 : 1
RPM: 10,000
TOOL CLAMPING: ER16A
CITIZEN ITEM NO.: KSC110(2x)
PRICE: \$5,825.00

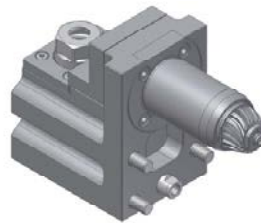

CTM3204162100
Axial for front working

RATIO: 1 : 1
RPM: 6,000
TOOL CLAMPING: ER16A
CITIZEN ITEM NO.: KSE110
PRICE: \$6,050.00

PART CATCHER

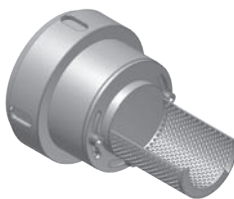

CTA900000
PART CATCHER

MACHINE / A32
PRICE: \$275.00

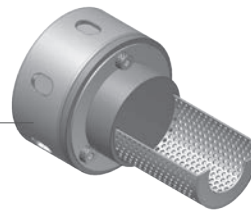

CTA900000-1
PART CATCHER

MACHINE / A20
PRICE: \$275.00

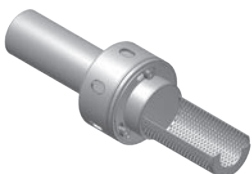

CTL900000
PART CATCHER

MACHINE / L20
PRICE: \$350.00

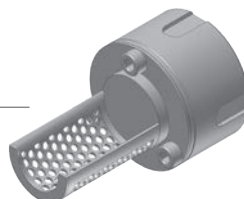

CTC900000
PART CATCHER

MACHINE / C16
PRICE: \$275.00



CTE900000
PART CATCHER

MACHINE / L20E
PRICE: \$275.00

CB25M/CB32M/CB36M TOOLING FOR CROSS TOOL POST

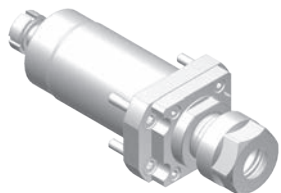

CCB121000
Cross drilling/milling unit

RATIO 1 : 1
RPM(MAX) 6000
TOOL CLAMPING ER20A
PRICE: \$1,300.00

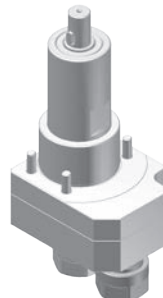

CCB162000
2 spindle cross drilling/milling unit

RATIO 1 : 1
RPM(MAX) 6000
TOOL CLAMPING ER16A
PRICE: \$2,425.00

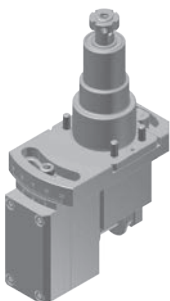

CCB130100
Gear hobbing unit

RATIO 1 : 1
RPM(MAX) 6000
CUTTER SHANK Ø10mm
CUTTER OD(MAX) Ø30mm
CUTTER LENGTH 20mm
ANGLE ADJUSTMENT ±20°
PRICE: \$4,050.00

CB25M/CB32M/CB36M TOOLING FOR FRONT WORKING TOOL POST

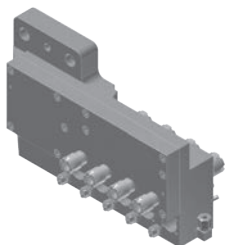

CCB562400
Front working tool base
(4 Live tool + 5 Fixed tool)

RATIO 1 : 2
RPM(MAX) 6000
TOOL CLAMPING
Front side : ER20M
Back side : ER16M
DRILL SLEEVE FOR FIXED TOOL PORT :
KDA2502060A (Single)
KDA2502100A (Double)
TOOL PORT / FIXED TOOL : T21~T25
LIVE TOOL : T26~T29
PRICE: \$7,275.00

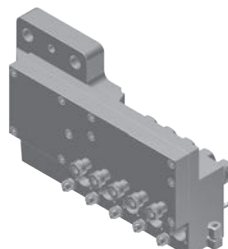

CCB566500
Front working tool base
(5 Live tool + 5 Fixed tool)

RATIO 1 : 2
RPM(MAX) 6000
TOOL CLAMPING
Front side : ER16A
Back side : ER11A
DRILL SLEEVE FOR FIXED TOOL PORT :
KDA2502060A (Single)
KDA2502100A (Double)
TOOL PORT / FIXED TOOL : T21~T25
LIVE TOOL : T26~T30
PRICE: \$7,675.00

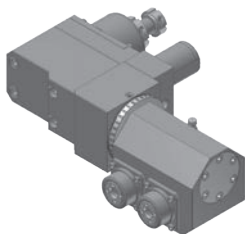

CCB491200
2 spindle drilling/milling unit

RATIO 1 : 1
RPM(MAX) 6000
TOOL CLAMPING ER11
ANGLE ADJUSTMENT ±180°
REMARK Only available for 3 Live tool +
5 Fixed tool base
PRICE: \$6,075.00

CB25M/CB32M/CB36M TOOLING FOR BACK TOOL POST

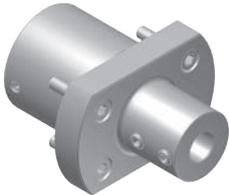

CCB601120
Boring bar sleeve

TOOL SHANK Ø42.0mm
BORING BAR SHANK Ø12.0mm
PRICE: \$250.00

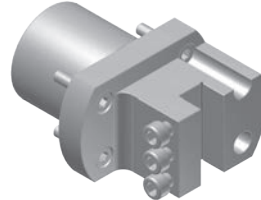

CCB611120
Turning tool holder

TOOL SHANK Ø42.0mm
BITE HOLDER SHANK 12x12mm
PRICE: \$250.00

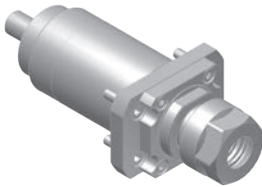

CCB721000
Drilling/milling unit

RATIO 1 : 1
RPM(MAX) 6000
TOOL CLAMPING ER20A
PRICE: \$1,300.00

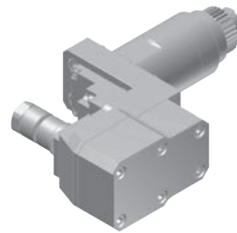

CCB730000
Slotting unit

RATIO 1 : 0.75
RPM(MAX) 3000
SAW OD(MAX) Ø45mm
SAW ARBOR SHANK Ø12.7mm
PRICE: \$3,225.00

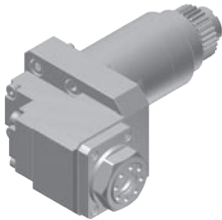

CCB761000
Cross drilling/milling unit

RATIO 1 : 1
RPM(MAX) 3000
TOOL CLAMPING ER16
PRICE: \$2,825.00

CY2-52MB TOOLING FOR BACK WORKING TOOL POST

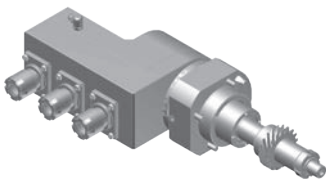

CCY496300
3 spindle drilling/milling unit

RATIO 1 : 1
RPM(MAX) 6000
TOOL CLAMPING ER16M
ANGLE ADJUSTMENT ±90°
PRICE: \$6,850.00

NCY25M/NCY32M/NCY36M TOOLING FOR CROSS TOOL POST

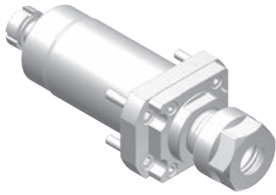

CCB121000
Cross drilling/milling unit

RATIO 1 : 1
RPM(MAX) 6000
TOOL CLAMPING ER20A
PRICE: \$1,300.00

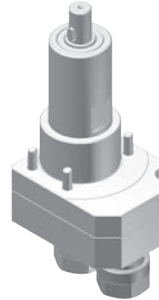

CCB162000
2 spindle cross drilling/ milling unit

RATIO 1 : 1
RPM(MAX) 6000
TOOL CLAMPING ER16A
PRICE: \$2,425.00

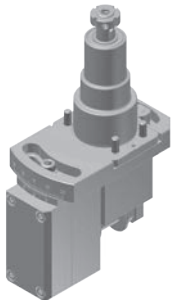

CCB130100
Gear hobbing unit

RATIO 1 : 1
RPM(MAX) 6000
CUTTER SHANK Ø10mm
CUTTER OD(MAX) Ø30mm
CUTTER LENGTH 20mm
ANGLE ADJUSTMENT ±20°
PRICE: \$4,050.00

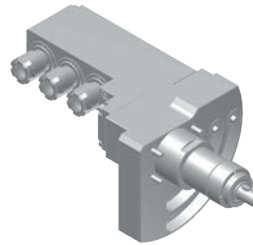

CCY463000
3 spindle drilling/milling unit

RATIO 1 : 1
RPM(MAX) 3000
TOOL CLAMPING ER16M
ANGLE ADJUSTMENT 0~90°
PRICE: \$5,650.00

NCY25M/NCY32M/NCY36M TOOLING FOR FRONT WORKING TOOL POST

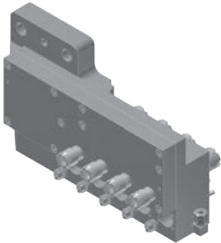

CCB562400
Front working tool base
(4 Live tool + 5 Fixed tool)

RATIO 1 : 2
RPM(MAX) 6000
TOOL CLAMPING
Front side : ER20M
Back side : ER16M
DRILL SLEEVE FOR FIXED TOOL PORT :
KDA2502060A (Single)
KDA2502100A (Double)
TOOL PORT / FIXED TOOL : T21~T25
LIVE TOOL : T26~T29
PRICE: \$7,275.00

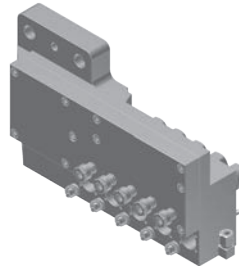

CCB566500
Front working tool base
(5 Live tool + 5 Fixed tool)

RATIO 1 : 2
RPM(MAX) 6000
TOOL CLAMPING
Front side : ER16A
Back side : ER11A
DRILL SLEEVE FOR FIXED TOOL PORT :
KDA2502060A (Single)
KDA2502100A (Double)
TOOL PORT / FIXED TOOL : T21~T25
LIVE TOOL : T26~T30
PRICE: \$7,675.00

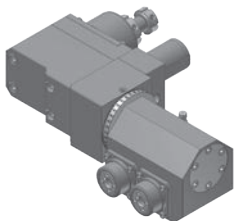

CCB491200
2 spindle drilling/milling unit

RATIO 1 : 1
RPM(MAX) 6000
TOOL CLAMPING ER11
ANGLE ADJUSTMENT ±180°
REMARK Only available for 3 Live tool +
5 Fixed tool base
PRICE: \$6,075.00

XD20/XD26 TOOLING FOR GANG TOOL POST

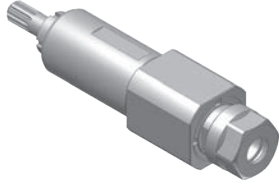

HWX246100
Cross drilling/milling unit

RATIO: 1:1
RPM(MAX): 8000
TOOL CLAMPING: ER16A
PRICE: \$1,200.00

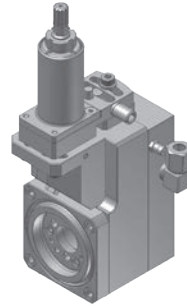

HWX260100
Thread whirling unit

RATIO: 1:1
RPM(MAX): 6000
THREAD(MAX): M12
HELIX ANGLE: $\pm 15^\circ$
PRICE: \$8,500.00

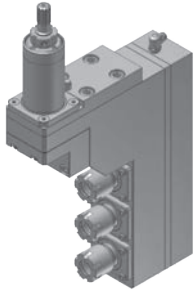

HWX446300
3 spindle drilling/milling unit

RATIO: 1:1
RPM(MAX): 6000
TOOL CLAMPING: ER16M
PRICE: \$6,350.00

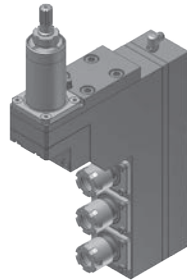

HWX546300
3 spindle drilling/milling unit

RATIO: 1:1
RPM(MAX): 6000
TOOL CLAMPING:
Front side: ER16M
Back side : ER11M
PRICE: \$6,850.00

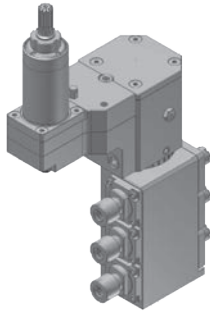

HWX591300
3 spindle drilling/milling unit

RATIO: 1:1
RPM(MAX): 8000
TOOL CLAMPING:
Front side: ER11M
Back side : ER8M
ANGLE ADJUSTMENT: $\pm 180^\circ$
PRICE: \$9,700.00

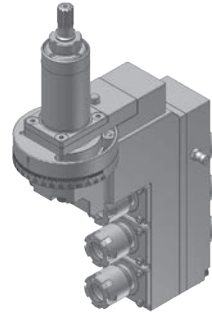

HWX596300
3 spindle drilling/milling unit

RATIO: 1:1
RPM(MAX): 8000
TOOL CLAMPING:
Front side: ER16M
Back side : ER11M
ANGLE ADJUSTMENT: $\pm 90^\circ$
PRICE: \$7,250.00

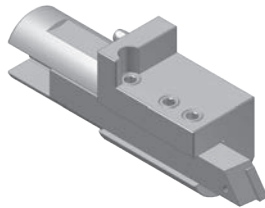

HWX2012100
Turning tool holder

TOOL SHANK: $\varnothing 30\text{mm}$
BITE HOLDER SHANK: 12x12mm
PRICE: \$350.00

XD32/XD35/XD38 TOOLING FOR GANG TOOL POST

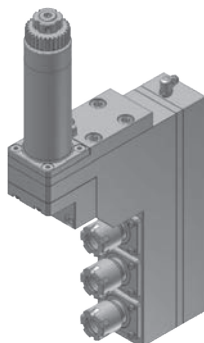

HWX446300-1
3 spindle drilling/milling unit

RATIO: 1:1
RPM(MAX): 6000
TOOL CLAMPING: ER16M
PRICE: \$6,850.00

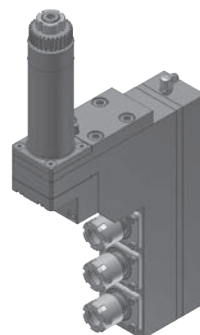

HWX546300-1
3 spindle drilling/milling unit

RATIO: 1:1
RPM(MAX): 6000
TOOL CLAMPING:
Front side: ER16M
Back side : ER11M
PRICE: \$7,250.00

XD20/XD26 TOOLING FOR BACK TOOL POST

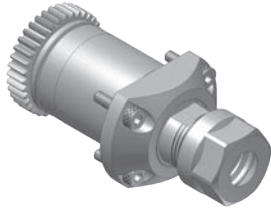

HWX746100
Drilling/milling unit

RATIO: 1:1
RPM(MAX): 8000
TOOL CLAMPING: ER16A
PRICE: \$1,200.00

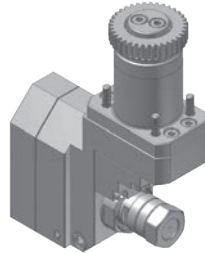

HWX730100
Slotting unit

RATIO: 1:0.55
RPM(MAX): 4000
SAW OD(MAX): Ø50mm
SAW ARBOR SHANK:
Ø5.0/6.0/8.0/10.0/12.7/13.0mm
PRICE: \$3,100.00

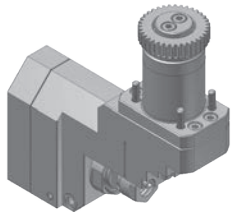

HWX731100-1
Slotting unit

RATIO: 1:0.55
RPM(MAX): 4000
TOOL CLAMPING: ER11A
PRICE: \$3,550.00



HWX746400
Cross drilling/milling and
Face drilling/milling unit
for sub spindle

RATIO: 1:1
RPM(MAX): 6000
TOOL CLAMPING: ER16M
PRICE: \$4,375.00

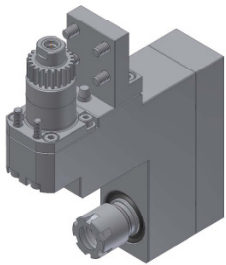

HWX866100
Cross drilling/milling unit

RATIO: 1:1
RPM(MAX): 6000
TOOL CLAMPING: ER16M
PRICE: \$4,025.00

XD32H / XD38H TOOLING FOR BACK TOOL POST

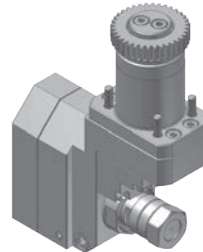

HWX736100
Slotting unit

RATIO: 1:0.77
RPM(MAX): 4000
TOOL CLAMPING: ER-16A
CENTER ADJUSTMENT: ±1 mm
PRICE: \$3,675.00

XD12H TOOLING FOR BACK TOOL POST

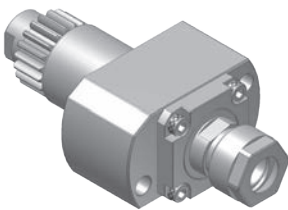

HWX741100
Drilling/milling unit

RATIO: 1:1
RPM(MAX): 6000
TOOL CLAMPING: ER11A
PRICE: \$1,200.00

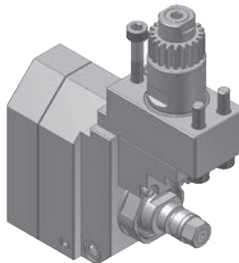

HWX731000
Slotting unit

RATIO: 1:0.55
RPM(MAX): 4000
SAW OD(MAX): Ø50
SAW ARBOR SHANK: Ø5.0/6.0/8.0/
12.7 mm
PRICE: \$3,100.00

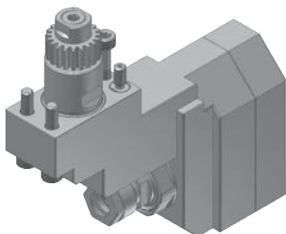

HWX731100
Slotting unit

RATIO: 1:0.55
RPM(MAX): 4000
TOOL CLAMPING: ER11A
PRICE: \$3,550.00

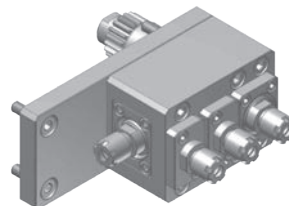

HWX748400
Cross drilling/milling unit
and
face drilling/milling unit

RATIO: 1:1
RPM(MAX): 8000
TOOL CLAMPING: ER8M
PRICE: \$4,375.00

SA20D/SA32D TOOLING FOR GANG TOOL POST

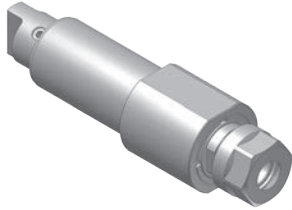

NTA246100
Cross drilling/milling
unit

RATIO 1 : 1
RPM(MAX) 6000
TOOL CLAMPING ER16A
PRICE: \$1,200.00

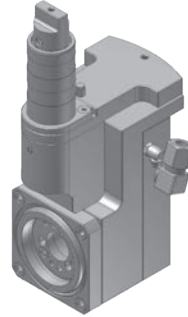

NTA260100
Thread whirling unit

RATIO 1 : 1
RPM(MAX) 6000
THREAD(MAX) M12
HELIX ANGLE $\pm 20^\circ$
PRICE: \$9,975.00

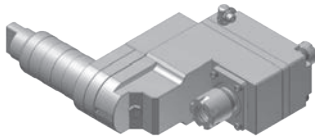

NTA566100
1 spindle drilling/milling unit

RATIO 1 : 1
RPM(MAX) 6000
TOOL CLAMPING
Front side : ER16
Back side : ER11M
PRICE: \$4,850.00

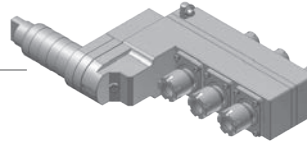

NTA566300
3 spindle drilling/milling unit

RATIO 1 : 1
RPM(MAX) 6000
TOOL CLAMPING
Front side : ER16M
Back side : ER11M
PRICE: \$5,650.00

SA20D TOOLING FOR BACK TOOL POST

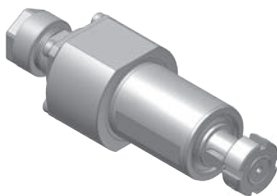

NTA741100
Drilling/milling unit

RATIO 1 : 1
RPM(MAX) 8000
TOOL CLAMPING ER11A
PRICE: \$1,100.00

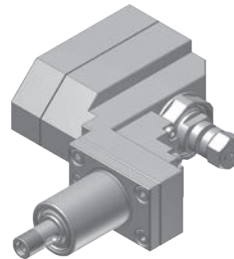

NTA730100-20
Slotting unit

RATIO 1 : 0.55
RPM(MAX) 4000
SAW OD(MAX) $\varnothing 50$ mm
SAW ARBOR SHANK $\varnothing 8.0$ mm
PRICE: \$4,050.00

SA32D TOOLING FOR BACK TOOL POST

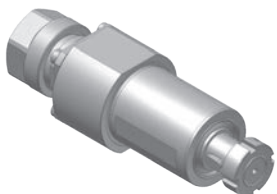

NTA746100
Drilling/milling unit

RATIO 1 : 1
RPM(MAX) 8000
TOOL CLAMPING ER16A
PRICE: \$1,100.00

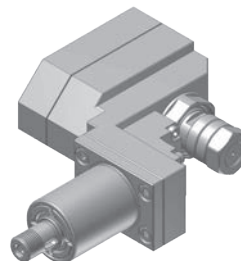

NTA730100-32
Slotting unit

RATIO 1 : 0.55
RPM(MAX) 4000
SAW OD(MAX) $\varnothing 50$
SAW ARBOR SHANK $\varnothing 12.0$ 12.7 13.0
PRICE: \$4,050.00

NN16SB6 TOOLING FOR GANG TOOL POST

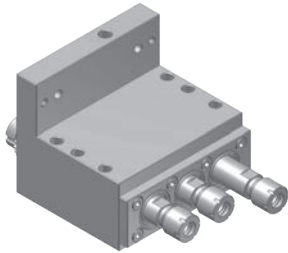

NUB261100
3 spindle drilling/milling unit

RATIO 1 : 1
RPM(MAX) 6000
TOOL CLAMPING ER11M
PRICE: \$4,850.00

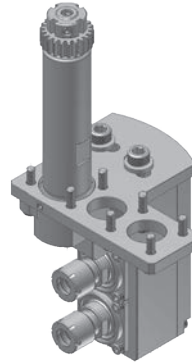

NUN412000
2 spindle drilling/milling unit

RATIO 1 : 1
RPM(MAX) 6000
TOOL CLAMPING ER11M
ANGLE ADJUSTMENT $\pm 10^\circ$
PRICE: \$5,250.00

NN16UB/NN20UB TOOLING FOR GANG TOOL POST



NUU266100
Cross drilling/milling unit

RATIO 1 : 1
RPM(MAX) 6000
TOOL CLAMPING ER16M
PRICE: \$1,100.00

NN20UB8 TOOLING FOR GANG TOOL POST

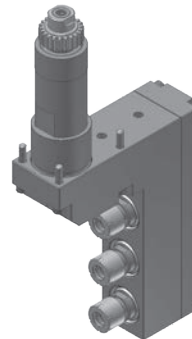

NUN441300-1
3 spindle drilling/milling unit

RATIO 1 : 1
RPM(MAX) 3000
TOOL CLAMPING ER11M
PRICE: \$6,850.00

NN32YB2 TOOLING FOR GANG TOOL POST

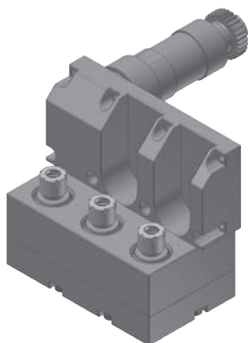

NUN441300
3 spindle drilling/milling unit

RATIO 1 : 1
RPM(MAX) 6000
TOOL CLAMPING ER11M
PRICE: \$7,325.00

TOOLING FOR GANG TOOL POST (SHANK Ø34mm)

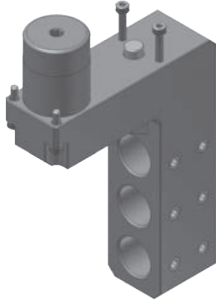

STR140300
3 tool sleeve holder

TOOL SHANK Ø34mm
DRILL SLEEVE SHANK Ø22 mm
Mounted on T3500
MACHINE: SR20R / SR32J
PRICE: \$825.00

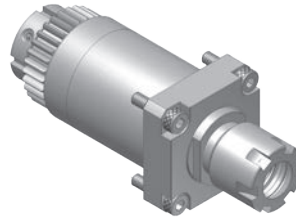

STR161000
Cross drilling/milling unit

RATIO 1:1
RPM(MAX) 8000
TOOL CLAMPING ER16M
STAR ITEM NO. 331-50
MACHINE: SR20R / SR32J
PRICE: \$1,250.00



STR161100
Cross drilling/milling unit

RATIO 3:1
RPM(MAX) 18000
TOOL CLAMPING ER11A
MACHINE: SR20R / SR32J
PRICE: \$3,675.00

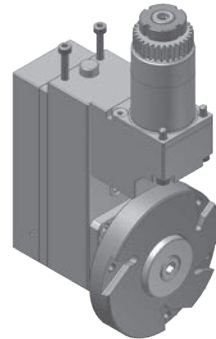

STR150100
Polygon unit

RATIO 1:1
RPM(MAX) 3000
CUTTER OD(MAX) Ø95 mm
MACHINE: SR20R / SR32J
PRICE: \$6,050.00



STR162100
Cross drilling/milling unit

RATIO 1:1
RPM(MAX) 8000
TOOL CLAMPING ER20M
MACHINE: SR20R / SR32J
PRICE: \$1,250.00



STR166100
Cross drilling/milling unit

RATIO 1:1
RPM(MAX) 8000
TOOL CLAMPING ER16M
STAR ITEM NO. 571-55
MACHINE: SR20R / SR32J
PRICE: \$1,350.00

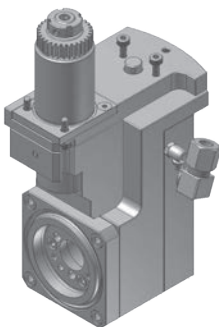

STR260100
Thread whirling unit

RATIO 1 : 1
RPM(MAX) 6000
THREAD(MAX) M12
HELIX ANGLE ±20°
MACHINE: SR20R
PRICE: \$8,500.00

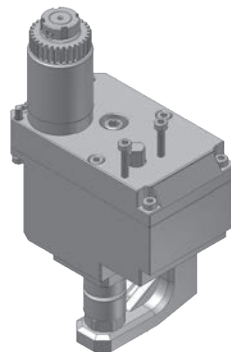

STR301000
Slotting unit

RATIO 1 : 0.374
RPM(MAX) 4000
SAW OD(MAX) Ø70 mm
SAW ARBOR SHANK Ø12.7 mm
MACHINE: SR20R
PRICE: \$6,475.00

TOOLING FOR GANG TOOL POST (SHANK Ø34mm)

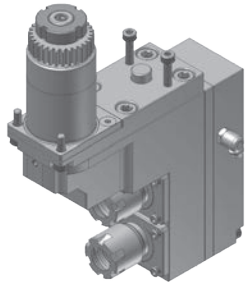

STR446200
2 spindle drilling/milling unit

RATIO 1 : 1
RPM(MAX) 6000
TOOL CLAMPING ER16M
STAR ITEM NO. 541-51
MACHINE: SR20R
PRICE: \$5,650.00

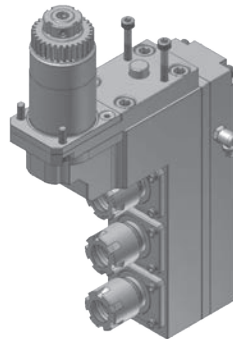

STR446300 / STR446300-1
3 spindle drilling/milling unit

RATIO 1 : 1
RPM(MAX) 6000
TOOL CLAMPING ER16M
STAR ITEM NO. STR446300 : 661-51
MACHINE: SR20R / SR32J
PRICE: \$6,050.00

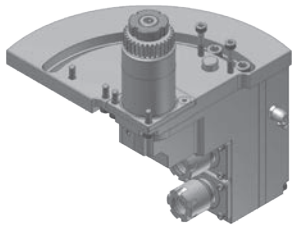

STR496200
2 spindle drilling/milling unit

RATIO 1 : 1
RPM(MAX) 6000
TOOL CLAMPING ER16M
ANGLE ADJUSTMENT 0~90°
MACHINE: SR20R
PRICE: \$6,450.00

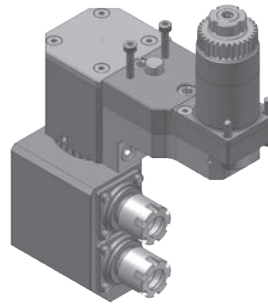

STR496200-2
2 spindle drilling/milling unit

RATIO 1 : 1
RPM(MAX) 6000
TOOL CLAMPING ER16M
ANGLE ADJUSTMENT ±180°
MACHINE: SR32J
PRICE: 7,675.00

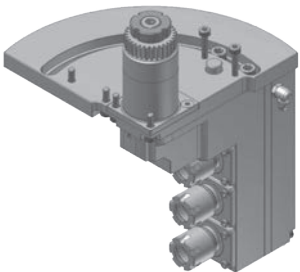

STR496300
3 spindle drilling/milling unit

RATIO 1 : 1
RPM(MAX) 6000
TOOL CLAMPING ER16M
ANGLE ADJUSTMENT 0~90°
MACHINE: SR20R
PRICE: \$6,850.00

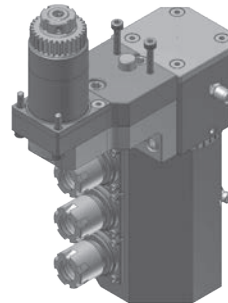

STR496300-2
3 spindle drilling/milling unit

RATIO 1 : 1
RPM(MAX) 6000
TOOL CLAMPING ER16M
ANGLE ADJUSTMENT ±180°
MACHINE: SR20R
PRICE: \$8,075.00

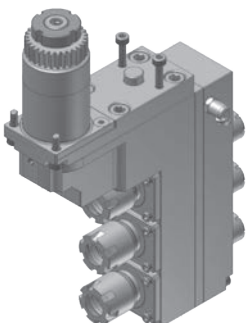

STR546300 / STR546300-1
3 spindle drilling/milling unit

RATIO 1 : 1
RPM(MAX) 6000
TOOL CLAMPING
Front side : ER16M
Back side : ER11M
STAR ITEM NO. STR546300-1 : 671-59
MACHINE: SR20R
PRICE: \$6,450.00

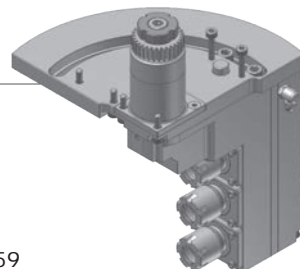

STR596300
3 spindle drilling/milling unit

RATIO 1 : 1
RPM(MAX) 6000
TOOL CLAMPING
Front Side: ER16M
Back Side: ER11
ANGLE ADJUSTMENT 0~90°
MACHINE: SR20R
PRICE: \$7,275.00

TOOLING FOR BACK TOOL POST (SHANK Ø16/Ø22mm)

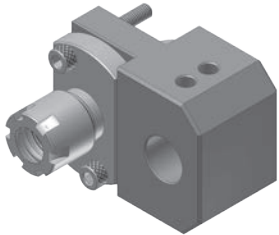

STJ640100
Extension tool holder

TOOL SHANK Ø22.0mm
TOOL CLAMPING ER16M
DRILL SLEEVE SHANK Ø16.0mm
MACHINE SR20J
PRICE: \$350.00

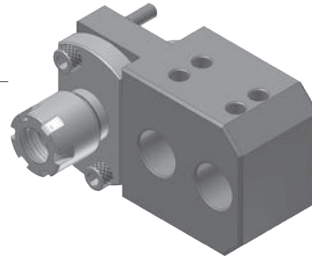

STJ640200
Extension tool holder

TOOL SHANK Ø22.0mm
TOOL CLAMPING ER16M
DRILL SLEEVE SHANK Ø16.0mm
MACHINE SR32J / JN
PRICE: \$375.00

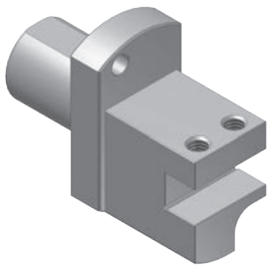

KDA22010SG
Turning tool holder

TOOL SHANK Ø22.0mm
BITE HOLDER SHANK 10x10mm
MACHINE: SR20R / SR20J /
SR32J
PRICE: \$200.00

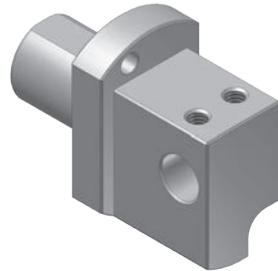

STR620100
Turning tool holder

TOOL SHANK Ø22.0mm
BITE HOLDER SHANK Ø12.0mm
MACHINE: SR20R / SR20J /
SR32J
PRICE: \$200.00

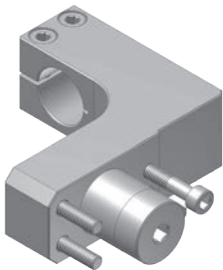

STR601000
Air tool holder

TOOL SHANK Ø22.0mm
AIR TOOL SHANK Ø20.0mm
MACHINE: SR20R
PRICE: \$200.00

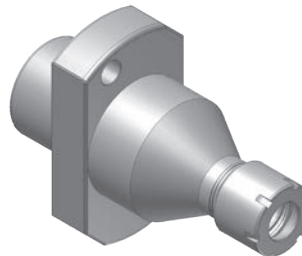

STR641100
Drill sleeve

TOOL SHANK Ø22.0mm
TOOL CLAMPING ER11M
MACHINE: SR20J
PRICE: \$150.00

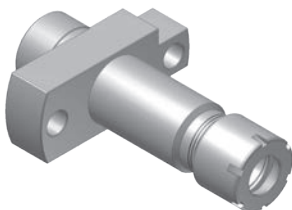

STR641100J
Drill sleeve

TOOL SHANK Ø16.0mm
TOOL CLAMPING ER11M
MACHINE SR10J
PRICE: \$150.00

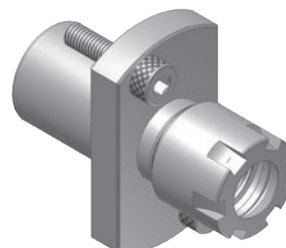

STR646100
Drill sleeve

TOOL SHANK Ø22.0mm
TOOL CLAMPING ER16M
MACHINE: SR20R / SR32J
PRICE: \$150.00

TOOLING FOR BACK TOOL POST (SHANK Ø22mm)

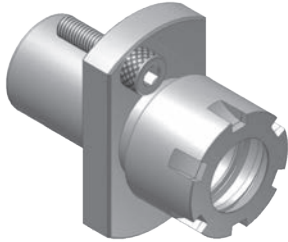

STR642100
Drill sleeve

TOOL SHANK Ø22.0mm
TOOL CLAMPING ER20M
MACHINE: SR20R / SR32J
PRICE: \$150.00

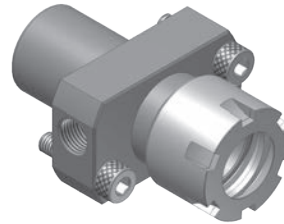

STR642100-1
Drill sleeve (Internal coolant type)

TOOL SHANK Ø22.0mm
TOOL CLAMPING ER20M
MACHINE: SR20R
PRICE: \$150.00

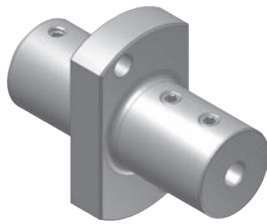

KSR22000
Boring bar sleeve

TOOL SHANK Ø22.0mm
BORING BAR SHANK
Ø3.0/4.0/5.0/6.0/8.0/10.0/12.0/16.0
mm
MACHINE: SR20R
PRICE: \$150.00

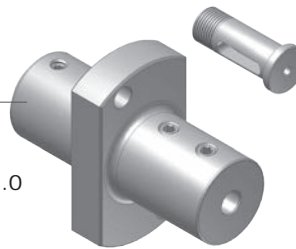

KSR22120
Boring bar sleeve (Bushing type)

TOOL SHANK Ø22.0mm
BUSHING OD Ø12.0mm
BUSHING ID (BORING BAR SHANK) /
Ø3.0/4.0/5.0/ 6.0/8.0/9.0/10.0mm
MACHINE: SR20R
PRICE: \$150.00

TOOLING FOR BACK TOOL POST (SHANK Ø22mm)

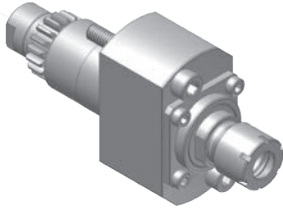

STR711000
Drilling/milling unit

RATIO 1 : 1
RPM(MAX) 6000
TOOL CLAMPING ER11M
STAR ITEM NO. 541-61
MACHINE: SR20R
PRICE: \$1,100.00

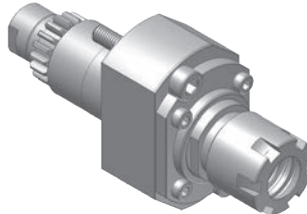

STR761000
Drilling/milling unit

RATIO 1 : 1
RPM(MAX) 6000
TOOL CLAMPING ER16M
STAR ITEM NO. 571-61
MACHINE: SR20R
PRICE: \$1,100.00



STR761200
Drilling/milling unit

RATIO 3 : 1
RPM(MAX) 18000
TOOL CLAMPING ER11/ER11M
MACHINE: SR20R/
ECAS12/ECAS20
PRICE: \$4,350.00

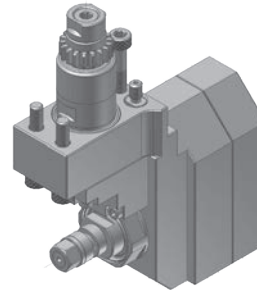

STR731000
Slotting unit

RATIO 1 : 0.55
RPM(MAX) 4000
SAW OD(MAX) Ø50
SAW ARBOR SHANK
Ø5.0/6.0/8.0/12.7/13.0mm
MACHINE: SR10J / SR20R
PRICE: \$3,100.00

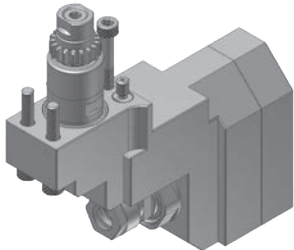

STR731100
Slotting unit

RATIO 1 : 0.55
RPM(MAX) 4000
TOOL CLAMPING ER11A
MACHINE: SR10J / SR20R
PRICE: \$3,800.00

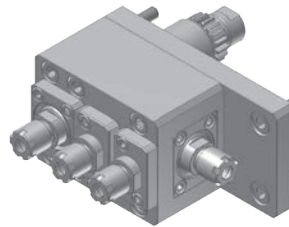

STR714000
Cross drilling/milling and
face drilling/milling unit

RATIO 1 : 1
RPM(MAX) 6000
TOOL CLAMPING ER8M
MACHINE SR10J
PRICE: \$4,375.00

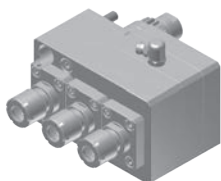

STR741300
3 spindle drilling/milling unit

RATIO 1 : 1
RPM(MAX) 8000
TOOL CLAMPING ER11M
MACHINE NEW TYPE SR20RIII
SR20J with PIN HOLE
(FANUC 31i VERSION)
PRICE: \$5,075.00

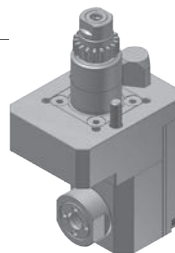

**STR811000-10J/
STR811000-20R**
Cross drilling/milling unit

RATIO 1 : 1
RPM(MAX) 6000
TOOL CLAMPING ER11
MACHINE: SR 10J / SR20R
PRICE: \$3,375.00

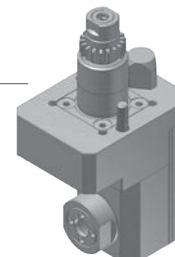

STR861100
Cross drilling/milling unit

RATIO 1 : 1
RPM(MAX) 8000
TOOL CLAMPING ER11M
MACHINE: SR20J/SB20R
PRICE: \$3,600.00

TOOLING FOR GANG TOOL POST SB16/SB20

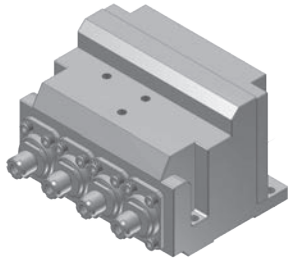

STB268400
4 spindle cross drilling/
milling unit

RATIO 1 : 1.5
RPM(MAX) 3000
TOOL CLAMPING ER8M
MACHINE: SB 16/20
PRICE: \$6,050.00

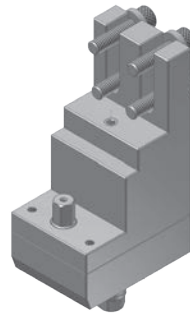

STB301000
Slotting unit

RATIO 1 : 0.392
RPM(MAX) 4000
SAW OD(MAX) Ø30
SAW ARBOR SHANK Ø6.0mm
MACHINE: SB20C
PRICE: \$2,025.00



STB401000
Air tool holder

TOOL SHANK Ø22.0mm
AIR TOOL SHANK Ø23.0mm
MACHINE: SB16R / SB20R
PRICE: \$550.00

TOOLING FOR TURRET TOOL POST (SHANK Ø44mm)

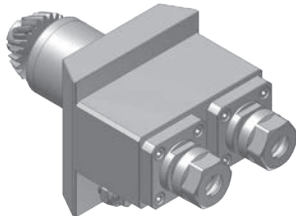

STV161200
2 spindle cross drilling/milling
unit

RATIO 1 : 1
RPM(MAX) 6000
TOOL CLAMPING ER16A
STAR ITEM NO. 421-51
MACHINE: SV20 / SV32
PRICE: \$6,075.00

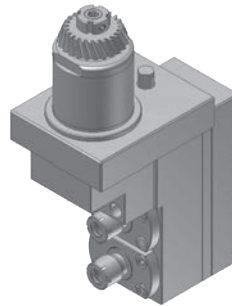

STV512000
2 spindle drilling/milling unit

RATIO 1 : 1.16
RPM(MAX) 6000
TOOL CLAMPING ER11M
STAR ITEM NO. 421-59
MACHINE: SV20 / SV32
PRICE: \$7,675.00

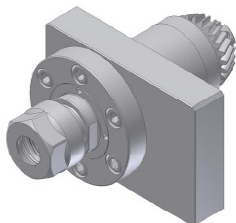

STV10302000
Cross drilling/milling unit

RATIO 1 : 1
RPM(MAX) 6000
TOOL CLAMPING ER20A
MACHINE: STAR SV32/ECAS32T/ST38
PRICE: \$4,850.00

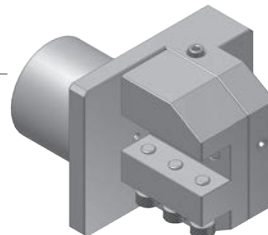

STV901000
Turning bite holder

TOOL SHANK Ø44.0mm
BITE HOLDER SHANK 16x16mm
CENTER ADJUSTMENT ±1mm
MACHINE: SV32J
PRICE: \$1,075.00

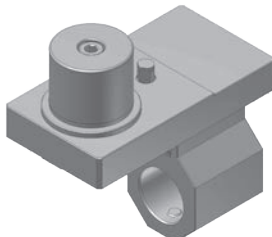

STV140100
1 station boring bar holder

TOOL SHANK Ø44.0mm
BORING BAR SHANK Ø32.0mm
MACHINE: SV20 / SV32 (Mounted
on Turret)
PRICE: \$825.00

JSL20RB/JSL20RBY TOOLING FOR GANG TOOL POST (SHANK : Ø34mm)

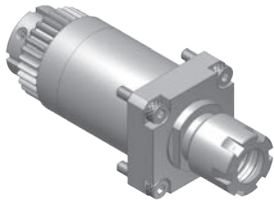

JSR161000
Cross drilling/milling unit

RATIO 1 : 1
RPM(MAX) 8000
TOOL CLAMPING ER16M
PRICE: \$1,250.00

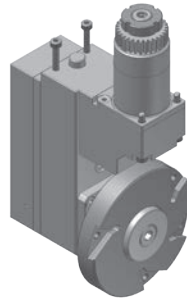

JSR150100
Polygon unit

RATIO 1 : 1
RPM(MAX) 3000
CUTTER OD(MAX) Ø95mm
PRICE: \$6,050.00

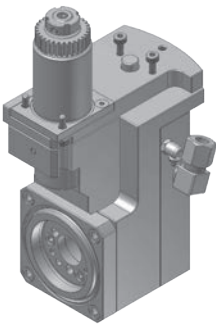

JSR260100
Thread whirling unit

RATIO 1 : 1
RPM(MAX) 6000
THREAD(MAX) M12
HELIX ANGLE ±15°
PRICE: \$8,500.00

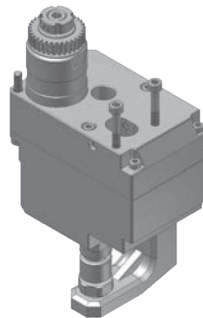

JSR301000
Slotting unit

RATIO 1 : 0.374
RPM(MAX) 4000
SAW OD(MAX) Ø70mm
SAW ARBOR SHANK Ø12.7mm
PRICE: \$6,450.00

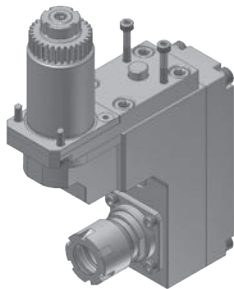

JSR442100
1 spindle drilling/milling unit

RATIO 1 : 1
RPM(MAX) 6000
TOOL CLAMPING ER20M
PRICE: \$5,425.00

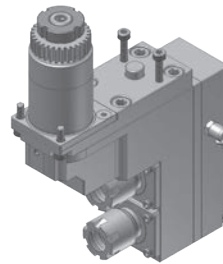

JSR446200
2 spindle drilling/milling unit

RATIO 1 : 1
RPM(MAX) 6000
TOOL CLAMPING ER16M
PRICE: \$5,650.00

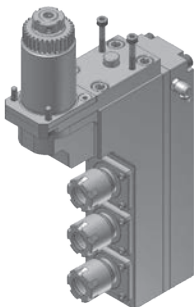

JSR446300-1
3 spindle drilling/milling unit

RATIO 1 : 1
RPM(MAX) 6000
TOOL CLAMPING ER16M
PRICE: \$6,850.00

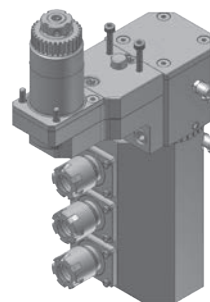

JSR496300-2
3 spindle drilling/milling unit

RATIO 1 : 1
RPM(MAX) 6000
TOOL CLAMPING ER16M
ANGLE ADJUSTMENT ±180°
PRICE: \$8,075.00

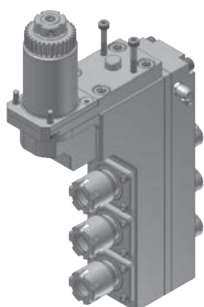

JSR546300-1
3 spindle drilling/milling unit

RATIO 1 : 1
RPM(MAX) 6000
TOOL CLAMPING
Front side : ER16M
Back side : ER11M
PRICE: \$6,450.00

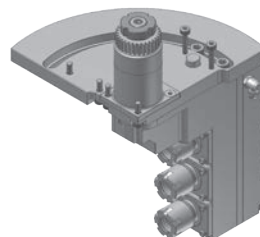

JSR596300-1
3 spindle drilling/milling unit

RATIO 1 : 1
RPM(MAX) 6000
TOOL CLAMPING
Front side : ER16M
Back side : ER11M
ANGLE ADJUSTMENT 0~90°
PRICE: \$7,250.00

JSL20RB/JSL20RBY TOOLING FOR BACK TOOL POST (SHANK Ø22mm)

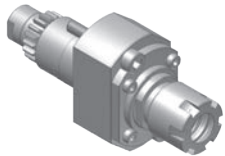

JSR761000
Drilling/milling unit
RATIO 1 : 1
RPM(MAX) 6000
TOOL CLAMPING ER16M
PRICE: \$1,100.00

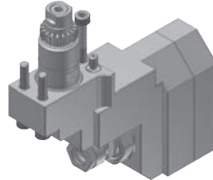

JSR731100
Slotting unit
RATIO 1 : 0.55
RPM(MAX) 4000
TOOL CLAMPING ER11A
CENTER ADJUSTMENT ±1mm
PRICE: \$3,800.00

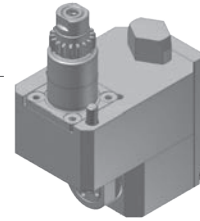

JSR861100
Cross drilling/milling unit
RATIO 1 : 1
RPM(MAX) 6000
TOOL CLAMPING ER11
PRICE: \$3,600.00

JSL26AB/JSL32AB/JSL42AB TOOLING FOR GANG TOOL POST (SHANK : Ø36mm)

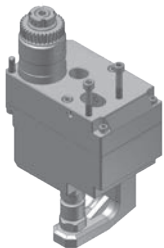

JSL301000
Slotting unit
RATIO 1 : 0.36
RPM(MAX) 3000
SAW OD(MAX) Ø70mm
SAW ARBOR SHANK Ø12.7mm
PRICE: \$6,450.00

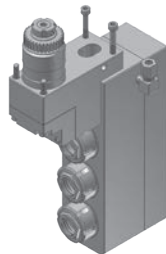

JSL523000
3 spindle drilling/milling unit
RATIO 1 : 1
RPM(MAX) 6000
TOOL CLAMPING
Front side : ER20
Back side : ER11M
PRICE: \$6,450.00



JSL806000
Thread whirling unit
RATIO 1 : 1
RPM(MAX) 6000
THREAD(MAX) M12
HELIX ANGLE ±15°
PRICE: \$9,975.00

TOOLING FOR BACK TOOL POST (SHANK Ø22mm)

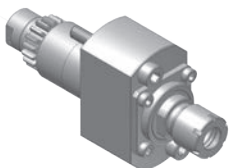

STR711000
Drilling/milling unit
RATIO 1 : 1
RPM(MAX) 6000
TOOL CLAMPING ER11M
STAR ITEM NO. 541-61
PRICE: \$1,100.00

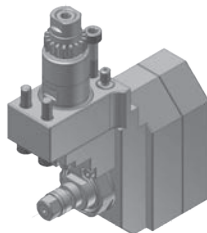

STR731000
Slotting unit
RATIO 1 : 0.55
RPM(MAX) 4000
SAW OD(MAX) Ø50
SAW ARBOR SHANK
Ø5.0/6.0/8.0/12.7/13.0mm
PRICE: \$3,100.00

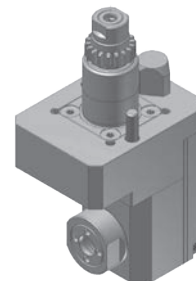

**STR811000-10J/
STR811000-20R**
Cross drilling/milling unit
RATIO 1 : 1
RPM(MAX) 6000
TOOL CLAMPING ER11
PRICE: \$3,350.00

GAMMA20 TOOLING FOR GANG TOOL POST

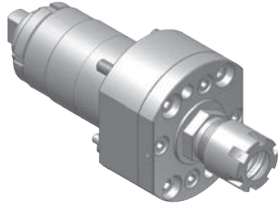

TSS161000
Cross drilling/milling unit

RATIO 1 : 1
RPM(MAX) 8000
TOOL CLAMPING ER16M
PRICE: \$1,300.00

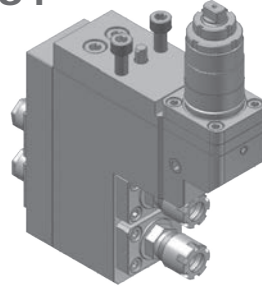

TSS562000
2 spindle drilling/milling unit

RATIO 1 : 1
RPM(MAX) 8000
TOOL CLAMPING
Front side : ER16M
Back side : ER11A
PRICE: \$6,450.00

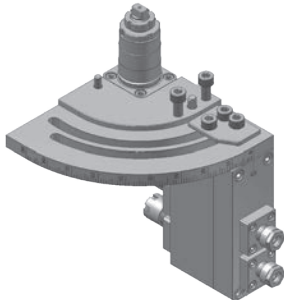

TSS562100
2 spindle drilling/milling unit

RATIO 1 : 1
RPM(MAX) 8000
TOOL CLAMPING
Front side : ER16M
Back side : ER11A
ANGLE ADJUSTMENT 0~90°
PRICE: \$6,875.00

DELTA38 TOOLING FOR GANG TOOL POST

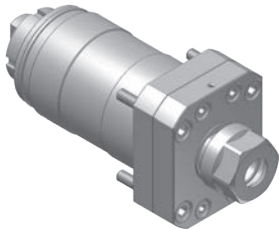

TSB246100
Cross drilling/milling unit

RATIO 1 : 1
RPM(MAX) 6000
TOOL CLAMPING ER16A
TSUGAMI ITEM NO. 3268-T051
PRICE: \$1,300.00

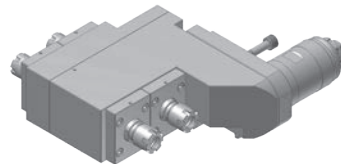

TSB546200
2 spindle drilling/milling unit

RATIO 1 : 1
RPM(MAX) 6000
TOOL CLAMPING ER16M
TSUGAMI ITEM NO. 3282-Y901
PRICE: \$6,450.00

GAMMA20 TOOLING FOR BACK TOOL POST

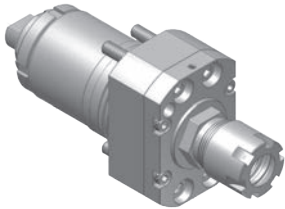

TSS761000
Drilling/milling unit

RATIO 1 : 1
RPM(MAX) 8000
TOOL CLAMPING ER16M
PRICE: \$1,200.00

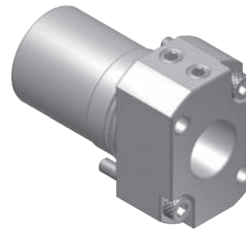

TSS601000
Tool adaptor

TOOL SHANK Ø35.0mm
SLEEVE SHANK Ø20.0mm
PRICE: \$250.00

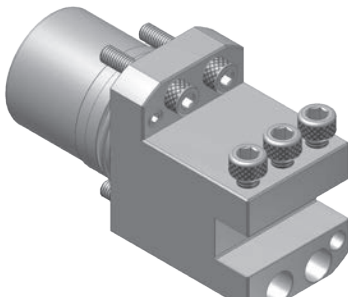

TSS620100
Turning tool holder

TOOL SHANK Ø35.0mm
BITE HOLDER SHANK 12x12mm
PRICE: \$250.00

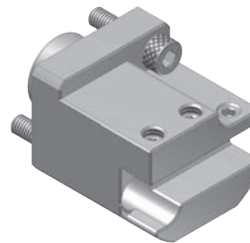

TSS620100-1
Turning tool holder

TOOL SHANK Ø35.0mm
BITE HOLDER SHANK 10x10mm
PRICE: \$250.00

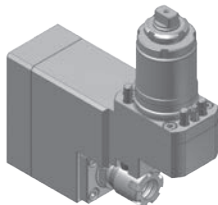

TSS861000
Slotting(Cross drilling/milling)
unit

RATIO 1 : 1
RPM(MAX) 6000
TOOL CLAMPING ER16M
PRICE: \$4,450.00

DELTA38 TOOLING FOR BACK TOOL POST

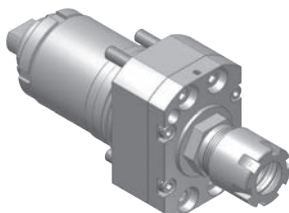

TSB746100
Drilling/milling unit

RATIO 1 : 1
RPM(MAX) 6000
TOOL CLAMPING ER16A
TSUGAMI ITEM NO. 3282-Y041
PRICE: \$1,225.00

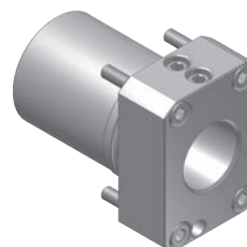

TSB640100
Tool adaptor

TOOL SHANK Ø42.0mm
SLEEVE SHANK Ø25.0mm
TSUGAMI ITEM NO. 3282-Y211
PRICE: \$250.00

S205/S206 TOOLING FOR GANG TOOL POST

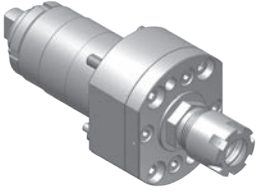

TSS161000
Cross drilling/milling unit

RATIO 1 : 1
RPM(MAX) 8000
TOOL CLAMPING ER16M
PRICE: \$1,300.00

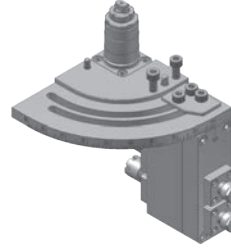

TSS562100
2 spindle drilling/milling unit

RATIO 1 : 1
RPM(MAX) 8000
TOOL CLAMPING
Front side : ER16M
Back side : ER11A
ANGLE ADJUSTMENT 0~90°
PRICE: \$6,875.00

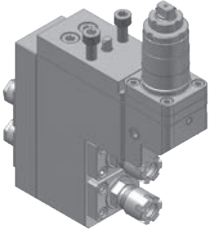

TSS562000
2 spindle drilling/milling unit

RATIO 1 : 1
RPM(MAX) 8000
TOOL CLAMPING
Front side : ER16M
Back side : ER11A
PRICE: \$6,450.00

S205/S206 TOOLING FOR BACK TOOL POST

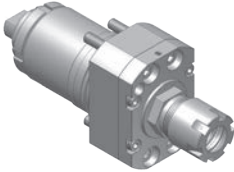

TSS761000
Drilling/milling unit

RATIO 1 : 1
RPM(MAX) 8000
TOOL CLAMPING ER16M
PRICE: \$1,200.00

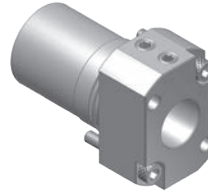

TSS601000
Tool adaptor

TOOL SHANK Ø35.0mm
SLEEVE SHANK Ø20.0mm
PRICE: \$250.00

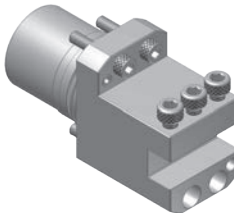

TSS620100
Turning tool holder

TOOL SHANK Ø35.0mm
BITE HOLDER SHANK
12x12mm
PRICE: \$250.00

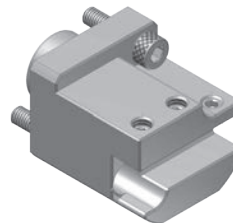

TSS620100-1
Turning tool holder

TOOL SHANK Ø20.0mm
BITE HOLDER SHANK
10x10mm
PRICE: \$250.00

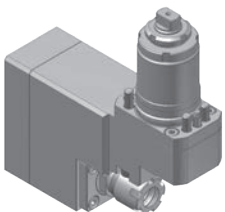

TSS861000
Slotting(Cross drilling/milling) unit

RATIO / 1 : 1
RPM(MAX) / 6000
TOOL CLAMPING / ER16M
PRICE: \$4,450.00

B0266/B0326 TOOLING FOR SUB SPINDLE

B026V TOOLING FOR GANG TOOL POST



TSB866100
Cross drilling/milling unit

RATIO 1 : 1
RPM(MAX) 6000
TOOL CLAMPING ER16M
TSUGAMI ITEM NO. 3290-Y041
PRICE: \$5,250.00

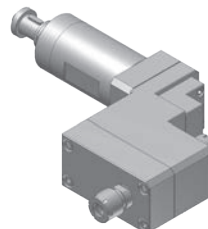

TSB511000
1 spindle drilling/milling unit

RATIO 1 : 1
RPM(MAX) 6000
TOOL CLAMPING ER16A
PRICE: \$5,650.00

B0385 TOOLING FOR GANG TOOL POST

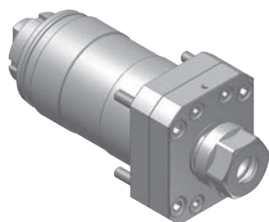

TSB246100
Cross drilling/milling unit

RATIO 1 : 1
RPM(MAX) 6000
TOOL CLAMPING ER16A
TSUGAMI ITEM NO. 3268-T051
PRICE: \$1,300.00

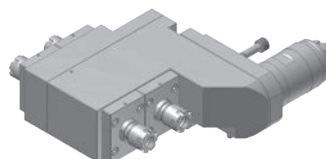

TSB546200
2 spindle drilling/milling unit

RATIO 1 : 1
RPM(MAX) 6000
TOOL CLAMPING ER16M
TSUGAMI ITEM NO. 3282-Y901
PRICE: \$6,450.00



TSB496200
2 spindle drilling/milling unit

RATIO 1 : 1
RPM(MAX) 6000
TOOL CLAMPING ER16M
ANGLE ADJUSTMENT 0~90°
PRICE: \$6,600.00



TSB596200
2 spindle drilling/milling unit

RATIO 1 : 1
RPM(MAX) 6000
TOOL CLAMPING ER16M
ANGLE ADJUSTMENT 0~90°
TSUGAMI ITEM NO. 3282-Y921
PRICE: \$7,025.00

B0385 TOOLING FOR BACK TOOL POST

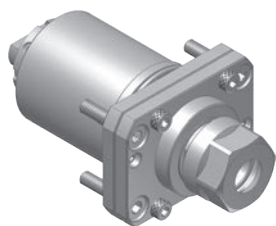

TSB746100
Drilling/milling unit

RATIO 1 : 1
RPM(MAX) 6000
TOOL CLAMPING ER16A
TSUGAMI ITEM NO. 3282-Y041
PRICE: \$1,200.00

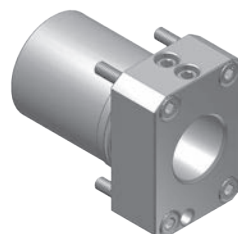

TSB640100
Tool adaptor

TOOL SHANK Ø42.0mm
SLEEVE SHANK Ø25.0mm
TSUGAMI ITEM NO. 3282-Y211
PRICE: \$250.00

B0125/B0205 TOOLING FOR GANG TOOL POST

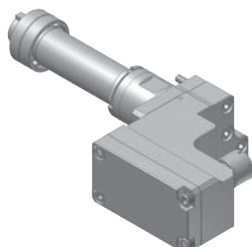

TSB411000
1 spindle drilling/milling unit

RATIO 1 : 1
RPM(MAX) 6000
TOOL CLAMPING ER16A
PRICE: \$4,850.00

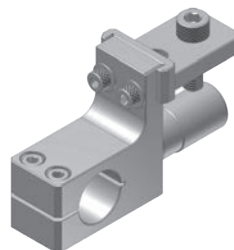

TSB601000
Air tool holder

TOOL SHANK Ø20.0mm
AIR TOOL SHANK Ø22.8mm
AIR TOOL Straight spindle
NR303
PRICE: \$250.00

B0266 / B0326 / B0385 TOOLING



TSB241100
Cross drilling/milling unit

RATIO 1 : 2
RPM(MAX) 12,000
TOOL CLAMPING ER11A
PRICE: \$3,700.00



TSB741100
Drilling/milling unit, sub

RATIO 1 : 2
RPM(MAX) 12,000
TOOL CLAMPING ER11A
PRICE: \$3,635.00

BROACHING HOLDER

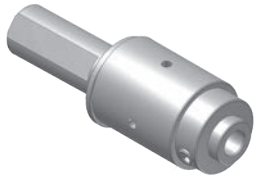

PT111600
BROACHING HOLDER

TOOL SHANK/Ø14 / Ø16mm
BROACHING TOOL SHANK / Ø8mm
BROACHING DEPTH/13mm
PRICE: \$1,100.00

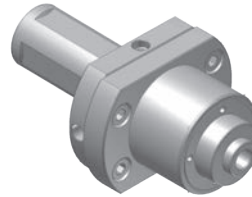

PT312500
BROACHING HOLDER

TOOL SHANK/ Ø25mm
BROACHING TOOL SHANK / Ø8mm
BROACHING DEPTH / 55mm
PRICE: \$1,475.00

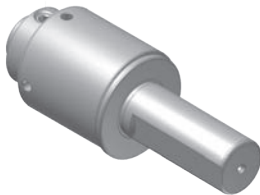

PT411600
BROACHING HOLDER

TOOL SHANK/Ø14 / Ø16mm
BROACHING TOOL SHANK / Ø8mm
BROACHING DEPTH / 13mm
PRICE: \$1,100.00

FLOATING REAMER HOLDER

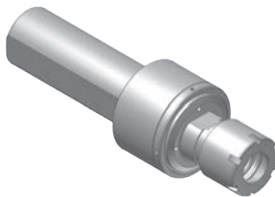

GP1116000
FLOATING REAMER HOLDER

TOOL SHANK / Ø16mm
TOOL CLAMPING / ER11M
PRICE: \$1,100.00

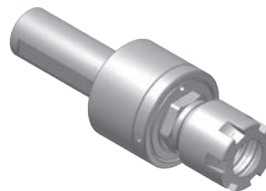

GP6116000
FLOATING REAMER HOLDER

TOOL SHANK / Ø16mm
TOOL CLAMPING / ER16M
PRICE: \$1,100.00



GP2125000
FLOATING REAMER HOLDER

TOOL SHANK / Ø25mm
TOOL CLAMPING / ER20
PRICE: \$1,475.00

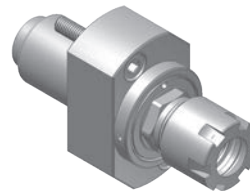

GP6122000
FLOATING REAMER HOLDER

TOOL SHANK / Ø22mm
TOOL CLAMPING / ER16M
MACHINE/STAR SR20R / SR20J
PRICE: \$1,100.00

SAW ARBOR



ITEM NO.	TOOL SHANK	SAW ARBOR SHANK	PRICE
I920254100A	Ø20mm	Ø25.4mm	\$325.00
I913254100A	Ø13mm	Ø25.4mm	\$325.00



ITEM NO.	TOOL SHANK	SAW ARBOR SHANK	PRICE
I907050060	Ø7mm	Ø5mm	\$75.00
I907060060	Ø7mm	Ø6mm	\$75.00
I910060090	Ø10mm	Ø6mm	\$100.00
I910127070	Ø10mm	Ø12.7mm	\$100.00

ITEM NO.	TOOL CLAMPING	SAW ARBOR SHANK	PRICE
I91606065	ER16	Ø6mm	\$125.00
I91106065	ER11	Ø6mm	\$125.00



TAPPING COLLET

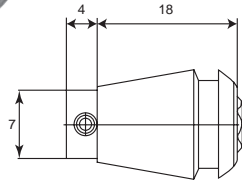

TP11000 TAPPING COLLET (ER11)
PRICE: \$175.00 EACH

ITEM NO.	STANDARD	TAP SPEC
TP1102000	ISO	NO.4
TP1102500	ISO	M1.0 ~ M2.0
	DIN	M1.0 ~ M1.8
TP1102800	ISO	M2.2 ~ M2.5
	DIN	M2.0 ~ M2.6
TP1103000	JIS	M1.0 ~ M2.6
TP1103150	ISO	M3.0
TP1103500	DIN	M3.0

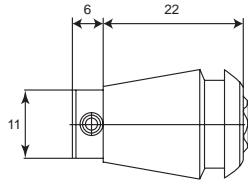

TP16000 TAPPING COLLET (ER16)
PRICE: \$175.00 EACH

ITEM NO.	STANDARD	TAP SPEC
TP1602000	ISO	NO.4
TP1602500	ISO	M1.0 ~ M2.0
	DIN	M1.0 ~ M1.8
TP1602800	ISO	M2.2 ~ M2.5
	DIN	M2.0 ~ M2.6
	JIS	M1.0 ~ M2.6
	ISO	M3.0
	DIN	M3.0
	ISO	M3.5
TP1604000	ISO	M4.0
	DIN	M3.5
	JIS	M3.0 ~ M3.5
TP1604500	ISO	M4.5
	DIN	M4.0
TP1605000	ISO	M5.0
	JIS	M4.0 ~ M4.5
TP1605500	JIS	M5.0
TP1606000	DIN	M4.5 ~ M8.0
	JIS	M6.0
TP1606200	JIS	M7.0 ~ M8.0
TP1606300	ISO	M6.0

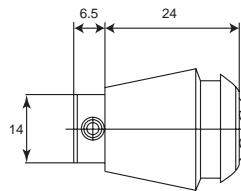

TP20000 TAPPING COLLET (ER20)
PRICE: \$175.00 EACH

ITEM NO.	STANDARD	TAP SPEC
TP2002500	ISO	M1.0-M2.0
	DIN	M1.0-M1.8
TP2002800	ISO	M2.2-M2.5
	DIN	M2.0-M2.6
TP2003000	JIS	M1.0-M2.6
TP2003150	ISO	M3.0
TP2003500	DIN	M3.0
TP2003550	ISO	M3.5
TP2004000	ISO	M4.0
	DIN	M3.5
	JIS	M3.0-M3.5
TP2004500	ISO	M4.5
	DIN	M4.0
TP2005000	ISO	M5.0
	JIS	M4.0 ~ M4.5
TP2005500	JIS	M5.0
TP2006000	DIN	M4.5 ~ M8.0
	JIS	M6.0
TP2006200	JIS	M7.0 ~ M8.0
TP2006300	ISO	M6.0
TP2007000	DIN	M9.0 ~ M10
	JIS	M9.0 ~ M10
TP2007100	ISO	M7.0
TP2008000	ISO	M8.0
	DIN	M11.0
	JIS	M11.0

DRILL SLEEVE (SINGLE ENDED)

PRICE: \$100.00 EACH

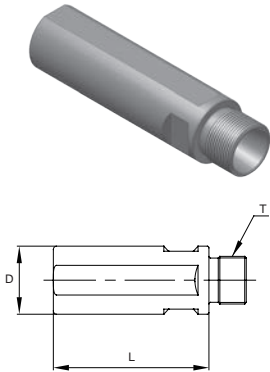

ITEM NO.	D	L	T	ITEM NO.	D	L	T	ITEM NO.	D	L	T
KDA10011050A	10.0	50	11	KDA16011050M	16.0	50	11	KDA22016117MC	22.0	117	16
KDA12011100A	12.0	100	11	KDA16011100M	16.0	100	11	KDA32025060UM	32.0	60	25
KDA14011050A	14.0	50	11	KDA10016060M	10.0	60	16				
KDA20011050A	20.0	50	11	KDA12016100M	12.0	100	16				
KDA20011070A	20.0	70	11	KDA16016100M	16.0	100	16				
KDA25016100A	25.0	100	16	KDA19516045M	19.05	45	16				
KDA25020060A	25.0	60	20	KDA19516100M	19.05	100	16				
KDA25020100A	25.0	100	20	KDA20016050M	20.0	50	16				
KDA25420150A	25.4	150	20	KDA20016070M	20.0	70	16				
				KDA22016100M	22.0	100	16				
				KDA23016075M	23.0	75	16				
				KDA25016050M	25.0	50	16				
				KDA25016080M	25.0	80	16				
				KDA22020110M	22.0	110	20				
				KDA25020050M	25.0	50	20				

DRILL SLEEVE (DOUBLE ENDED)

PRICE: \$150.00 EACH

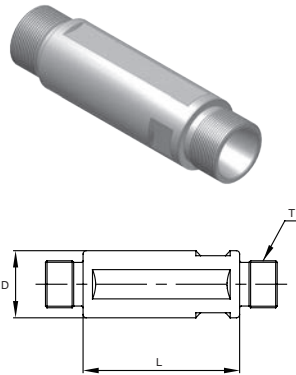

ITEM NO.	D	L	T	ITEM NO.	D	L	T
KDB20011033A	20.0	33	11	KDB17011090M	17.0	90	11
KDB20011050A	20.0	50	11	KDB19511060M	19.05	60	11
KDB20011070A	20.0	70	11	KDB22011075M	22.0	75	11
KDB20011078A	20.0	78	11	KDB19516060M	19.05	60	16
KDB25020045A	25.0	45	20	KDB20016050M	20.0	50	16
KDB25020075A	25.0	75	20	KDB20016070M	20.0	70	16
				KDB22016060M	22.0	60	16
				KDB22016075M	22.0	75	16
				KDB22016090M	22.0	90	16
				KDB23016060M	23.0	60	16
				KDB25016040M	25.0	40	16
				KDB25016075M	25.0	75	16
				KDB25416055M	25.4	55	16
				KDB25416070M	25.4	70	16
				KDB32020080M	32.0	80	20

DRILL SLEEVE (COOLANT THRU TYPE)

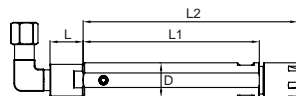
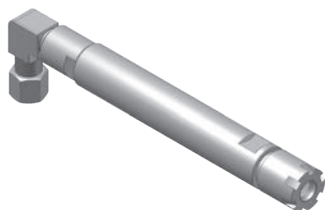

PRICE: \$450.00 EACH

ITEM NO.	TOOL CLAMPING	L	L1	L2	D
TL632211700	ER16-M	22	117	143	22
TL632205500	(coolant through type)	22	55	81	22

KNURLING HOLDER

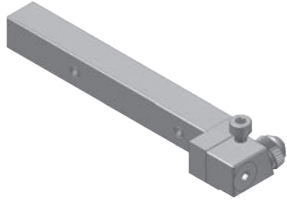

KC1R11260300

TOOL SHANK 10/12/16/20mm
KNURLING TOOL DIMENSION /
10 : 11x3x6mm
12 : 11x3x6mm
16 : 15x4x9mm
20 : 20x5x11mm
PRICE: \$650.00

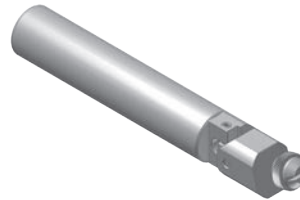

KC2R21660300

TOOL SHANK / Ø16mm
KNURLING TOOL DIMENSION /
11x3x6mm
PRICE: \$650.00

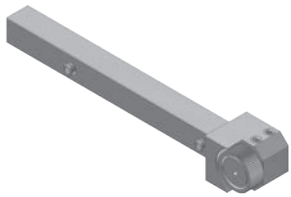

KK1L11060600

TOOL SHANK /10/12/16/20mm
KNURLING TOOL DIMENSION /
10 : 15x6x6/11mm
12 : 15x6x6/11mm
16 : 15x6x6/11mm
20 : 20x6x8/13mm
PRICE: \$225.00

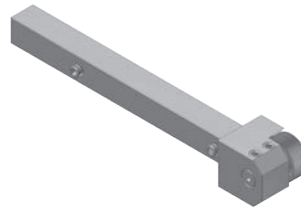

KK1R11060600

TOOL SHANK /10/12/16/20mm
KNURLING TOOL DIMENSION /
10 : 15x6x6/11mm
12 : 15x6x6/11mm
16 : 15x6x6/11mm
20 : 20x6x8/13mm
PRICE: \$225.00

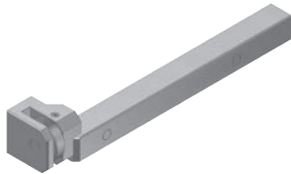

KK1R31040400

TOOL SHANK /10/12/16mm
KNURLING TOOL DIMENSION /
15x4x4mm
PRICE: \$225.00

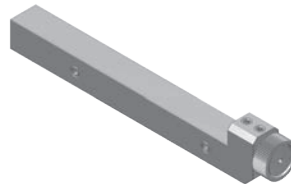

KK1R31260600

TOOL SHANK /12mm
KNURLING TOOL DIMENSION /
15x6x6/11mm
PRICE: \$225.00

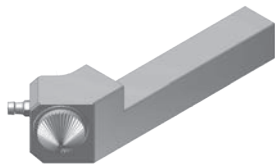

KK1R32081400

TOOL SHANK /20mm
KNURLING TOOL DIMENSION /
22x8x46mm
PRICE: \$600.00

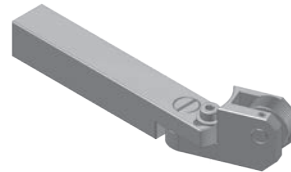

KK1R41660800

TOOL SHANK /16mm
KNURLING TOOL DIMENSION /
20x6x8mm
PRICE: \$650.00



KK2R21660600

TOOL SHANK / Ø16mm
KNURLING TOOL DIMENSION /
15x6x6/11mm
PRICE: \$225.00

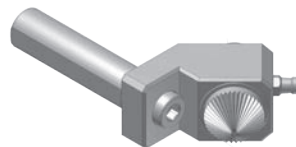

KK2R31681400

TOOL SHANK / Ø16mm
KNURLING TOOL DIMENSION /
22x8x46mm
PRICE: \$600.00



KK2R32060600

TOOL SHANK / Ø20mm
KNURLING TOOL DIMENSION /
15x6x6/11mm
PRICE: \$225.00

FIXTURE

PRICE: \$100.00 EACH

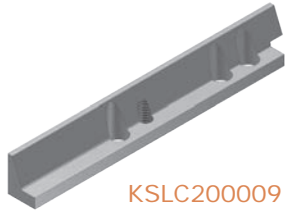

KSLC200009
CITIZEN L20



KSLC32007
CITIZEN L25/L32



KTC3000007
TSUGAMI BO18



KTC3000008
TSUGAMI NP17



KTC206000
KTC206001
TSUGAMI S206



KSR2000080
KSR2000081
STAR SR20R



KSR2000082
STAR SR20JC

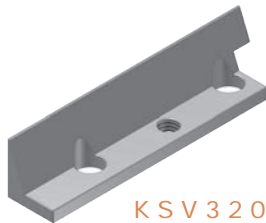

KSV320000
STAR SV32



KSV320001
STAR SV32

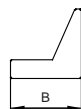
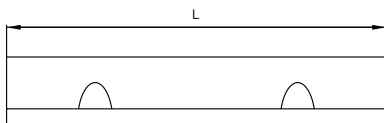

ITEM NO.	LENGTH(L)	HEIGHT(B)	THICKNESS
KSR2000080	75	14	3.5
KSR2000081	65	14	3.5
KSR2000082	75	13	6.5
KSV320000	70	14	3.5
KSV320001	80	14	3.5
KSLC20009	115	11	4.5
KSLC32007	115	12.5	4
KTC3000007	60	18	6
KTC3000008	58	15.6	11
KTC206000	70	15	10
KTC206001	70	12	10

ADJUSTABLE BORING BAR SLEEVE

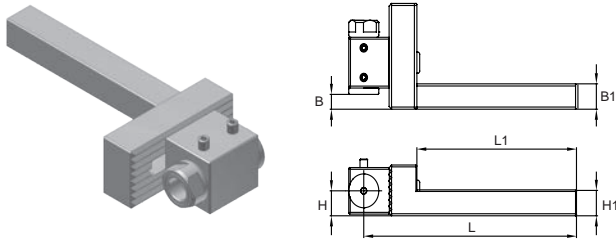

PRICE: \$375.00 EACH

ITEM NO.	L	L1	H	H1	B	B1
ATE140000	113.3	85	12	12	4~23	12

BORING BAR SLEEVE

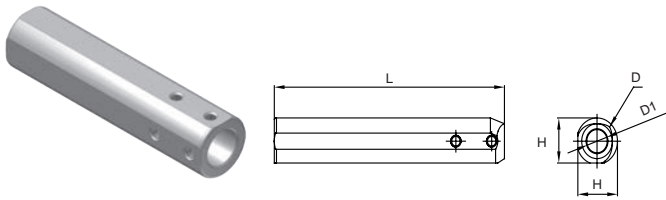

PRICE: \$150.00 EACH

ITEM NO.	L	D	D1
TE1905120N	100	19.05	12
TE2000120N	80	20	12
TE2200120N	100	22	12
TE2300120N	80	23	12
TE2500120N	120	25	12
TE2540120N	120	25.4	12

BORING BAR SLEEVE BUSHING

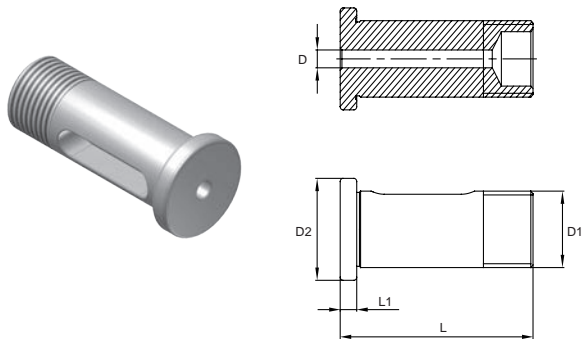

PRICE: \$100.00 EACH

ITEM NO.	L	L1	D	D1	D2
TE1203	35	3	3	12	16
TE1204	35	3	4	12	16
TE1205	35	3	5	12	16
TE1206	35	3	6	12	16
TE1208	35	3	8	12	16
TE1209	35	3	9	12	16
TE1210	35	3	10	12	16



20 Thompson Rd | East Windsor | CT 06088
1.800.249.5662 | 860.623.4132 Fax
www.komaprecision.com | info@komaprecision.com

ROTARY TABLES | ANGLE HEADS | LIVE TOOLS | SWISS TOOLS | TOOL PRESETTERS