

# LYNDEX NIKKEN

CUSTOMTOOLS™ CATALOG







## ANGLEHEADS™

Lyndex-Nikken AngleHeads are designed to easily and effectively upgrade your machine tool capabilities. RiteAngleHeads, FixedAngleHeads, FlexHeads, Slim RiteAngleHeads and Twin Spindle AngleHeads expand the capabilities of your existing machines.



## HISPINNERS™

HiSpinners increase your tooling RPMs by up to 10 times (up to 40,000 RPM), enabling you to reduce your cycle times and per-piece costs with your current machines. Minimize spindle wear by letting the tool do the work.

## FLUIDHEADS™

Lyndex-Nikken FluidHeads deliver coolant to the point of contact. Heat generated from cutting is eliminated so there is no warping, while cutting tool life is increased and tool breakage is reduced. FluidHeads also provide lubrication and promote superior chip breakage and chip evacuation.

# TABLE OF CONTENTS

## ANGLEHEADS™

	AngleHeads™ Technical Characteristics and Features .....4 - 5
	Nikken Heavy-Duty RiteAngleHeads™ .....6
	Standard RiteAngleHeads™ .....7
	Offset Type and Coolant-Through Offset Type RiteAngleHeads™ .....8
	Economy 40 Taper RiteAngleHeads™ .....9
	Slim Type RiteAngleHeads™ .....10
	Twin Spindle AngleHeads™ .....11
	Universal FlexHeads™ - Internal Coolant .....12
	Quick Change AngleHeads™ .....13 - 14
	AngleHeads™ Specials .....15
	AngleHeads™ Positioning Blocks.....16

## SPEED INCREASERS



HiSpinner™ Technical Characteristics and Features .....17

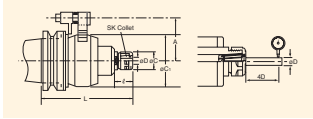

Nikken Standard HiSpinner™ .....18

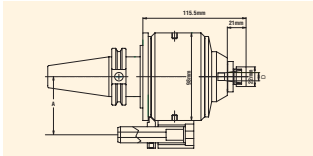

Advanced HiSpinner™ .....19

## FLUIDHEADS™

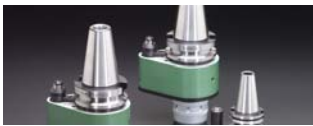

Nikken FluidHeads™ Features, Technical Characteristics and Stopper Blocks .....20 - 21

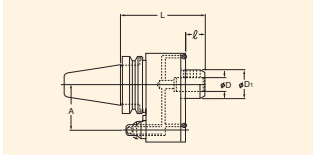

Nikken Side Lock FluidHeads™ .....22

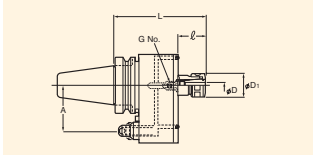

Nikken SK FluidHeads™ .....23

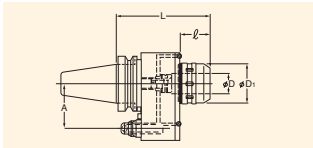

Nikken Ultra Lock FluidHeads™ .....24

## COLLETS



AngleHeads™ ER Collets (Inch, Metric, Coolant).....25 - 28

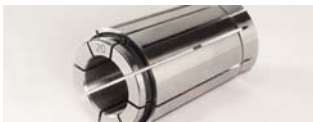

AngleHeads™, HiSpinners™ and FluidHeads™ SK Collets .....29 - 30



KM, ETS and CCK Collets (Inch, Metric, Coolant) .....31 - 32

## **ANGLEHEADS™ Technical Characteristics and Features**

Our AngleHeads are equipped with hardened and ground gears and collet shafts. Units are also fitted with high-precision angular contact bearings, assuring extreme rigidity and accuracy. Compact designs maintain accurate spindle and tool centerline alignment while minimizing tool overhang - accuracy is maintained throughout the machining process from plane to plane.



### **Vernier Scales and Positioning Rings**

Vernier scales help to orient the cutting tool location (0 - 360°).



### **Wrenches**

The proper wrenches are included with the purchase of your AngleHead.



### **Collet Seats**

Our new Collet Seats provide stable and secure gripping force by having the collet sit totally inserted within the body of the AngleHead.



### **Locking Pin / Stopper Pin**

The positioning pin and ring can also be oriented (0- 360°) to match your machining center's spindle and automatic tool changer configuration by simply adjusting the positioning ring. Their design allows them to be used in most ATCs and machine tool magazines without interference.



### **Collet Nut**

Combined with our new Collet Seat, featuring grooves and ridges for tightening, the absence of the external nut creates better rigidity and a smaller profile.

# ANGLEHEADS™ Technical Characteristics and Features



- High-precision spindle bearing, P4 quality
- Stabilized spindle bearing
- Bevel gear sets with helical toothing
- Permanent lubrication
- AngleHead can be rotated through 360° and is infinitely variable
- 4 x fixed 90° positioning points/ indexations
- High speeds up to 15,000 rpm and high torques up to 150 Nm

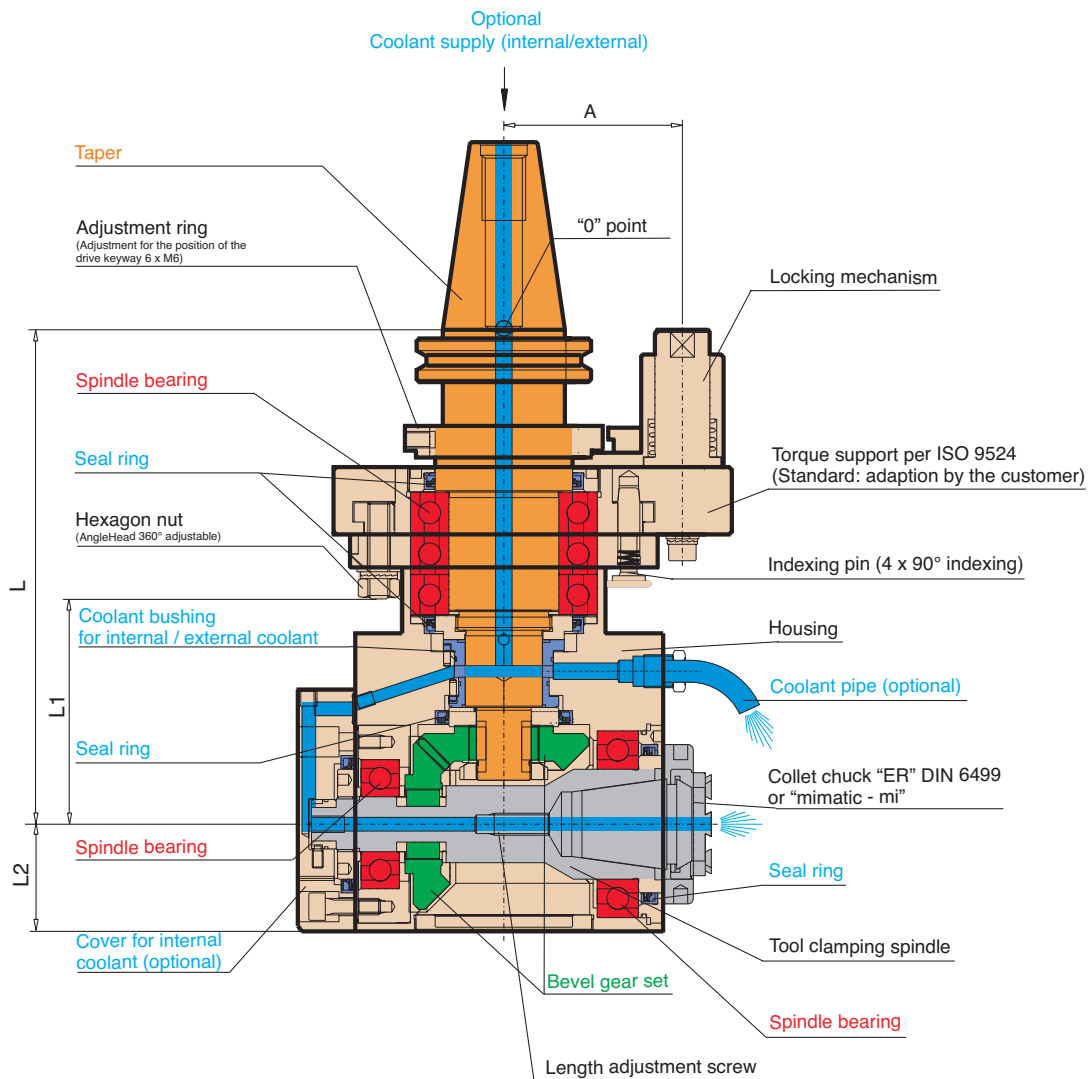

## NIKKEN HEAVY DUTY RITEANGLEHEADS™



Offset style pictured

### Features

- Specially designed for heavy milling
- Heavy endmilling and drilling capability
- Ideal for smooth ball endmilling of dies and molds
- 90° angular head
- Multilock milling chuck nose ensures excellent rigidity and accuracy
- Gear ratio: 1:1
- Wrenches are included

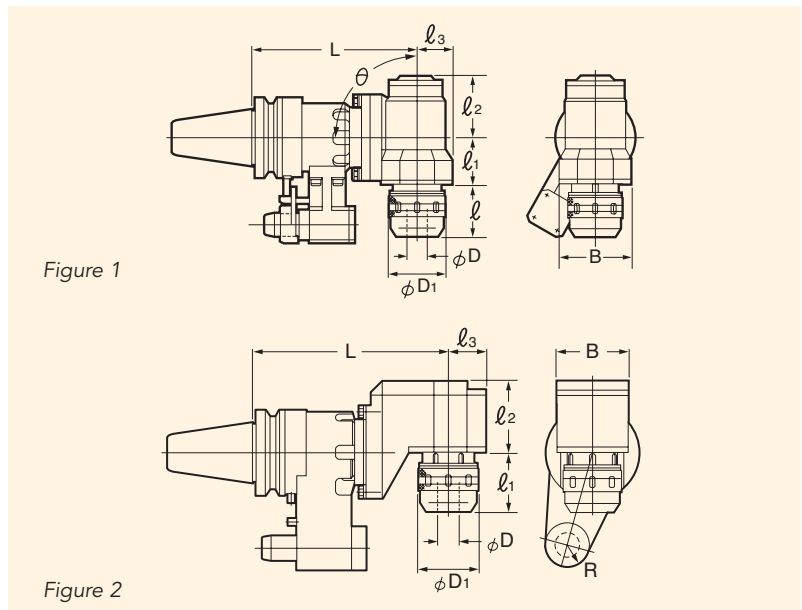

Figure 1

Figure 2

Part Number	Taper	Collet Series	Weight (lbs.)	D	D <sub>1</sub>	l	l <sub>1</sub>	l <sub>2</sub>	l <sub>3</sub>	B	RPM
<b>Figure 1</b>											
CAT40-AHK16-190-90	CAT40	SK16	19	2.75~16	40	25	41	58	35	70	4,000
BT40-AHK16-180-90	BT40		35								
CAT50-AHK16-200-90	CAT50	KM3/4	16	2~20	52	57	58	61	37	80	2,000
CAT40-AHC3/4-160-90	CAT40										
BT40-AHC3/4-160-90	BT40										
CAT50-AHC1.1/4-210-90	CAT50	KM 1-1/4	39	33~32	69	57	60	82	45	90	2,000

Part Number	Taper	Collet Series	Weight (lbs.)	D	D <sub>1</sub>	l <sub>1</sub>	l <sub>2</sub>	l <sub>3</sub>	B	R	RPM
<b>Figure 2</b>											
CAT40-AFC3/4-205-90	CAT40	KM3/4	19	2~20	52	56	85	35	70	17.5	2,000
BT40-AFC3/4-200-90	BT40					58				25	
CAT50-AFC1.1/4-230-90	CAT50	KM 1-1/4	37					45	84	25	

\* Positioning block (PB-RAN) not included. Please refer to page 16.

\*\* SK Collets available on pages 29-30.

\*\*\* KM Collets available on page 31.



**STANDARD RITEANGLEHEADS™**



**Features**

- Rigid, accurate and powerful
- Ideal for milling, drilling and tapping applications
- Full 360° body rotation with positive compression locking
- 90° incremental repositioning without indicating
- Spindle rotation is reversed
- Accommodated by most ATCs
- Universal ring primary alignment with main spindle's drive keys
- Maximum torque: 150 Nm
- Gear ratio: 1:1
- Wrenches are included

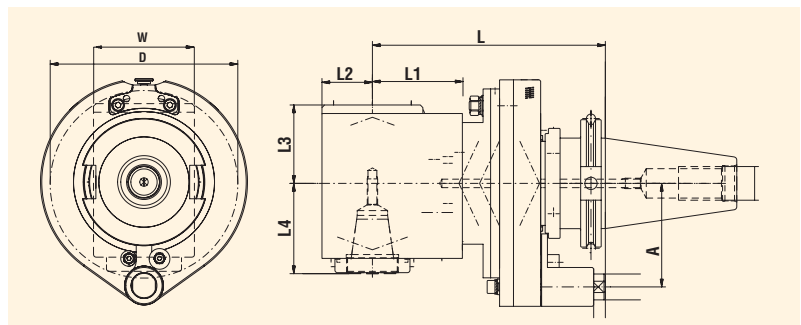

D: minimum bore

Part Number	Taper	Weight (lbs.)	L	L1	L2	L3	L4	A	W	D
<b>Collet Series - ER16</b> (12 Nm Torque, 6,500 RPM)										
C40RAM-ER16-180	CAT40	13	180	80	22	29.0	45.0	65	44	80
B40RAM-ER16-187	BT40	13	187	80	22	29.0	45.0	65	44	80
H63ARAM-ER16-187	HSK63A	13	187	80	22	29.0	45.0	65	44	80
<b>Collet Series - ER25</b> (30 Nm Torque, 8,000 RPM)										
C40RAM-ER25-180	CAT40	14	180	80	34	41.5	57.5	65	68	110
B40RAM-ER25-187	BT40	14	187	80	34	41.5	57.5	65	68	110
H63ARAM-ER25-187	HSK63A	14	187	80	34	41.5	57.5	65	68	110
C50RAM-ER25-180	CAT50	23	180	70	34	41.5	57.5	80	68	110
B50RAM-ER25-190	BT50	23	190	70	34	41.5	57.5	80	68	110
H10ARAM-ER25-190	HSK100A	23	190	70	34	41.5	57.5	80	68	110
<b>Collet Series - ER32</b> (70 Nm Torque, 6,500 RPM)										
C40RAM-ER32-180	CAT40	18	180	80	37	61.0	70.0	65	78	145
B40RAM-ER32-187	BT40	18	187	80	39	61.0	70.0	65	78	145
H63ARAM-ER32-187	HSK63A	18	187	80	39	61.0	70.0	65	78	145
C50RAM-ER32-180	CAT50	26	180	70	39	61.0	70.0	80	78	145
B50RAM-ER32-190	BT50	26	190	70	39	61.0	70.0	80	78	145
H10ARAM-ER32-190	HSK100A	26	190	70	39	61.0	70.0	80	78	145
<b>Collet Series - ER40</b> (150 Nm Torque, 5,000 RPM)										
C50RAM-ER40-215	CAT50	36	215	105	52	70.0	96.5	80	104	185
B50RAM-ER40-225	BT50	36	225	105	52	70.0	96.5	80	104	185
H10ARAM-ER40-225	HSK100A	36	225	105	52	70.0	96.5	80	104	185

\* Positioning block not included. Please refer to page 16.

\*\* ER Collets available on pages 25-28.

## OFFSET TYPE AND COOLANT-THROUGH OFFSET TYPE RITEANGLEHEADS™



### Features

- Minimizes the distance between the centerline of the angle head and cutting tool edge
- Solid and rigid construction
- Full 360° body rotation with positive compression locking
- 90° incremental repositioning without indicating
- Maximum torque: 150 Nm
- Gear ratio: 1:1
- Matches main spindle direction
- Wrenches are included

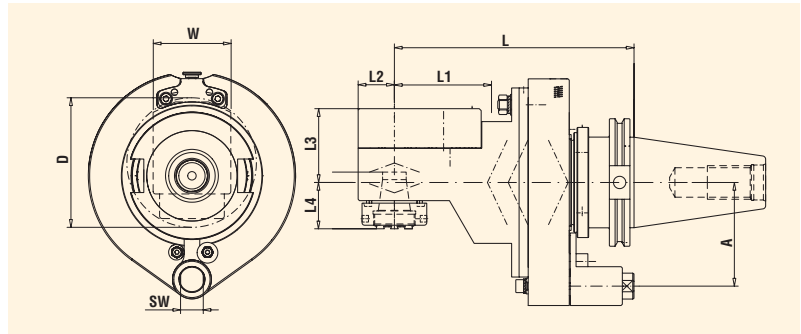

D: minimum bore

### Standard (non-coolant)

Part Number	Taper	Weight (lbs)	L	L1	L2	L3	L4	A	W	D
<b>Collet Series - ER25 (30 Nm Torque, 8,000 RPM)</b>										
C40RAM-ER25-180OT	CAT40	14	180	80	28	57	35.8	65	60	100
B40RAM-ER25-187OT	BT40	15	187	80	28	57	35.8	65	60	100
H63ARAM-ER25-187OT	HSK63A	14	187	80	28	57	35.8	65	60	100
C50RAM-ER25-185OT	CAT50	25	185	75	28	57	35.8	80	60	100
B50RAM-ER25-195OT	BT50	26	195	75	28	57	35.8	80	60	100
H10ARAM-ER25-195OT	HSK100A	24	195	75	28	57	35.8	80	60	100
<b>Collet Series - ER32 (70 Nm Torque, 6,000 RPM)</b>										
C40RAM-ER32-200OT	CAT40	19	200	100	38	77.5	32.2	65	80	120
B40RAM-ER32-207OT	BT40	19	207	100	38	77.5	32.2	65	80	120
H63ARAM-ER32-207OT	HSK63A	19	207	100	38	77.5	32.2	65	80	120
C50RAM-ER32-200OT	CAT50	29	200	100	38	77.5	32.2	80	80	120
B50RAM-ER32-210OT	BT50	29	210	100	38	77.5	32.2	80	80	120
H10ARAM-ER32-210OT	HSK100A	29	210	100	38	77.5	32.2	80	80	120
<b>Collet Series - ER40 (150 Nm Torque, 5,000 RPM)</b>										
C50RAM-ER40-260OT	CAT50	40	260	110	52	89	34.8	80	104	140
B50RAM-ER40-270OT	BT50	42	270	110	52	89	34.8	80	104	140
H10ARAM-ER40-270OT	HSK100A	39	270	110	52	89	34.8	80	104	140

### Coolant-Through

Part Number	Taper	Weight (lbs)	L	L1	L2	L3	L4	A	W	D
C40RAM-ER25-180OTC	CAT40	14	180	80	28	57	35.8	65	60	100
C50RAM-ER32-200OTC	CAT50	29	200	100	38	77.5	32.2	80	80	120

\* Positioning block not included. Please refer to page 16.

\*\* ER Collets available on pages 25-28.

## ECONOMY 40 TAPER RITEANGLEHEADS™



### Features

- Maximum speed: 2,000 RPM
- ER25 Collets (0.039" to 0.629" capacity)
- A positioning block adapter and a chuck nut wrench are included
- The ER25 Economy RiteAngleHead permits you to realize the benefits of a RiteAngleHead at a lower cost than one of our deluxe models. Its speed and work load ratings are sufficient for most operations
- Full 360° body rotation with positive compression locking
- 90° incremental repositioning without indicating
- Matches main spindle direction
- Accommodated by most ATCs
- Universal ring primary alignment with main spindle's drive keys
- Wrenches are included

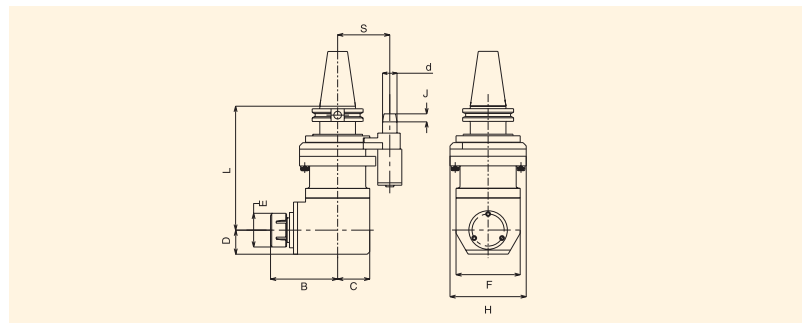

Part Number	Taper	Weight (lbs.)	L	S	D	C	B	F	H	E
C40RA-0025	CAT40	16	6.08"	65mm	1.18"	1.57"	3.29"	3.15"	3.74"	1.65"
B40RA-0025	BT40	16	5.90"	65mm	1.18"	1.57"	3.29"	3.15"	3.74"	1.65"

\* Positioning adapter PA-1 is included.

\*\* ER Collets available on pages 25-28.



## SLIM TYPE RITEANGLEHEADS™



### Features

- Minimized body size is suitable for machining in tight spaces
- Rigid, accurate, and powerful
- Ideal for drilling and tapping operations
- This unit can be rotated 360° and is compatible with most Automatic Tool Changers (ATCs)
- Spindle rotation is reversed
- Gear ratio: 1:1
- Special orders are available upon request
- Wrenches are included

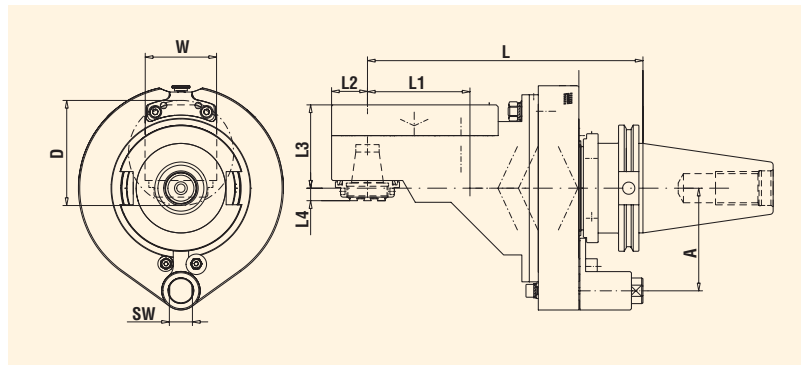

D: minimum bore

Part Number	Taper	Weight (lbs.)	L	L1	L2	L3	L4	A	W	D
<b>Collet Series - ER11 (15 Nm Torque, 10,000 RPM)</b>										
C40RAM-ER11-208ST	CAT40	15.5	208	76	37.2	37.2	1.9	65	36	45
C50RAM-ER11-208ST	CAT50	26	208	76	37.2	37.2	1.9	65	36	45
<b>Collet Series - ER20 (15 Nm Torque, 10,000 RPM)</b>										
C40RAM-ER20-225ST	CAT40	13	225	80	24	54.5	11.2	65	48	70
B40RAM-ER20-232ST	BT40	13	232	80	24	54.5	11.2	65	48	70
H63ARAM-ER20-232ST	HSK63A	13	232	80	24	54.5	11.2	65	48	70
<b>Collet Series - ER25 (30 Nm Torque, 8,000 RPM)</b>										
C40RAM-ER25-215ST	CAT40	14	215	80	28	65	10	65	56	82
B40RAM-ER25-222ST	BT40	14	222	80	28	65	10	65	56	82
H63ARAM-ER25-222ST	HSK63A	14	222	80	28	65	10	65	56	82
C50RAM-ER25-215ST	CAT50	26	215	80	28	65	10	80	56	82
B50RAM-ER25-225ST	BT50	27.5	225	80	28	65	10	80	56	82
H10ARAM-ER25-225ST	HSK100A	25	225	80	28	65	10	80	56	82
<b>Collet Series - ER32 (70 Nm Torque, 6,000 RPM)</b>										
C50RAM-ER32-285ST	CAT50	27.5	285	100	38	66	10	80	80	102
B50RAM-ER32-295ST	BT50	30	295	100	38	66	10	80	80	102
H10ARAM-ER32-295ST	HSK100A	26	295	100	38	66	10	80	80	102

\* Positioning block not included. Please refer to page 16.

\*\* ER Collets available on pages 25-28.

## TWIN SPINDLE ANGLEHEADS™



### Features

- Performs two milling and boring operations simultaneously in opposite directions
- Eliminates the need to have two AngleHeads
- Full 360° body rotation with positive compression locking
- 90° incremental repositioning without indicating
- Spindles rotate in opposite directions
- Maximum torque: 150 Nm
- Gear ratio: 1:1
- Wrenches are included

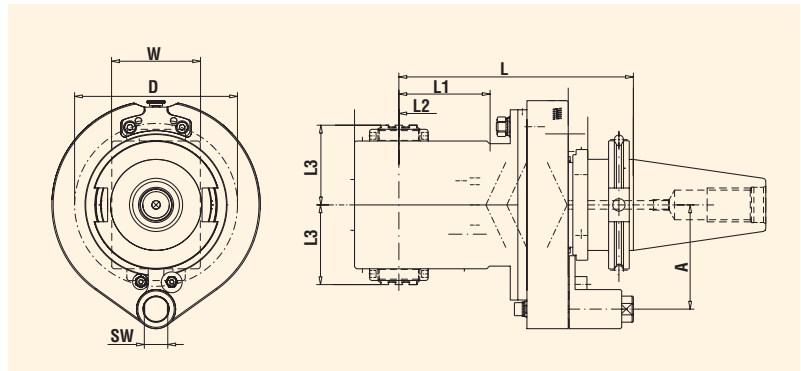

D: minimum bore

Part Number	Taper	Weight (lbs)	L	L1	L2	L3	A	W	D
<b>Collet Series - 2xER25 (30 Nm Torque, 8,000 RPM)</b>									
C40RAM-ER25-180TS	CAT40	16.5	180	80	34	61.2	65	68	125
B40RAM-ER25-187TS	BT40	16.5	187	80	34	61.2	65	68	125
H63ARAM-ER25-187TS	HSK63A	16.5	187	80	34	61.2	65	68	125
C50RAM-ER25-180TS	CAT50	25	180	70	34	61.2	80	68	125
B50RAM-ER25-190TS	BT50	25	190	70	34	61.2	80	68	125
H10ARAM-ER25-190TS	HSK100A	25	190	70	34	61.2	80	68	125
<b>Collet Series - 2xER32 (70 Nm Torque, 6,500 RPM)</b>									
C40RAM-ER32-180TS	CAT40	19	180	80	39	71.2	65	78	152
B40RAM-ER32-187TS	BT40	19	187	80	39	71.2	65	78	152
H63ARAM-ER32-187TS	HSK63A	19	187	80	39	71.2	65	78	152
C50RAM-ER32-180TS	CAT50	30	180	70	39	71.2	80	78	152
B50RAM-ER32-190TS	BT50	30	190	70	39	71.2	80	78	152
H10ARAM-ER32-190TS	HSK100A	27.5	190	70	39	71.2	80	78	152
<b>Collet Series - 2xER40 (150 Nm Torque, 4,000 RPM)</b>									
C50RAM-ER40-215TS	CAT50	43	215	165	54	103	80	108	210
B50RAM-ER40-225TS	BT50	44	225	165	54	103	80	108	210
H10ARAM-ER40-225TS	HSK100A	42	225	165	54	103	80	108	210

\* Positioning block not included. Please refer to page 16.

\*\* ER Collets available on pages 25-28.

## UNIVERSAL FLEXHEADS™ - Internal Coolant



### Features

- 360° angle positioning with precise independent vernier alignment
- The body can be rotated 360° and is compatible with most Automatic Tool Changers (ATCs)
- Spindle rotation is reversed
- Gear ratio: 1:1
- Special configurations are available upon request
- Wrenches are included
- No dry running

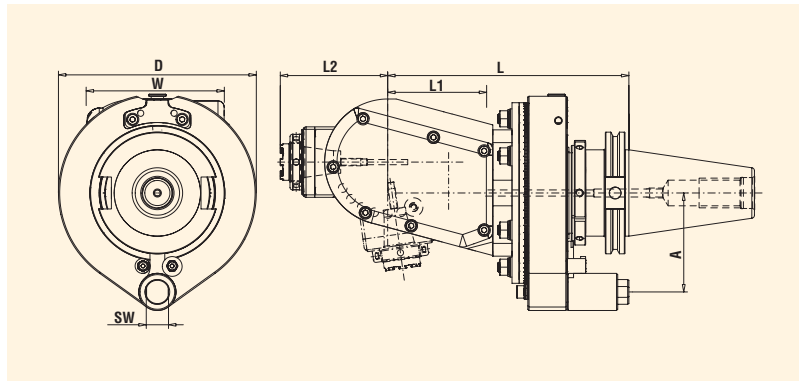

D: minimum bore

Part Number	Taper	Weight (lbs.)	L	L1	L2	A	W	D
<b>Collet Series - ER25 (30 Nm Torque, 7,000 RPM)</b>								
C40FHM-ER25-195C	CAT40	21	195	80	87	65	86	127
B40FHM-ER25-202C	BT40	21	202	80	87	65	86	127
H63AFHM-ER25-202C	HSK63A	21	202	80	87	65	86	127
C50FHM-ER25-195C	CAT50	31	195	80	87	80	86	127
B50FHM-ER25-205C	BT50	33	205	80	87	80	86	127
H10AFHM-ER25-205C	HSK100A	30	205	80	87	80	86	127
<b>Collet Series - ER32 (70 Nm Torque, 6,000 RPM)</b>								
C50FHM-ER32-210C	CAT50	32	210	90	105	80	123	175
B50FHM-ER32-220C	BT50	34	220	90	105	80	123	175
H10AFHM-ER32-220C	HSK100A	31	220	90	105	80	123	175

\* Positioning block not included. Please refer to page 16.

\*\* Universal FlexHeads must only be used with coolant through the spindle - no dry running.

\*\*\* ER Collets available on pages 25-28.

## QUICK CHANGE ANGLEHEADS™



### Features

- A variety of adapters are available to enable quick change operations
- Universal tool clamping system for all production areas
- Presetting of the tools off-line by length adjustment screw
- Spindle rotation is reversed
- Tool change within seconds
- Concentricity of the interface < 0.002mm
- Secure holding force by form-locking
- Very short design
- Toolholders in different sizes
- Gear ratio: 1:1
- Wrenches are included

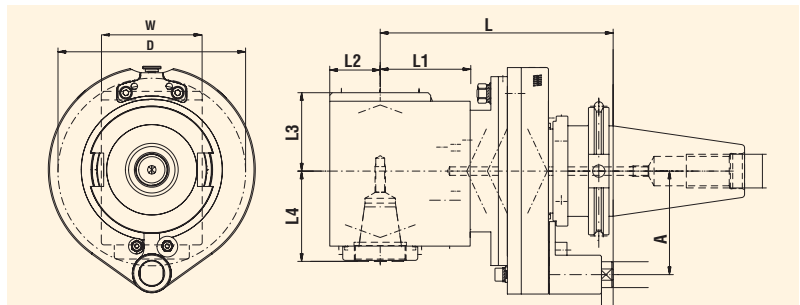

D: minimum bore

Part Number	Taper	Weight (lbs.)	L	L1	L2	L3	L4	A	W	D
<b>Collet Series - MI50 (70 Nm Torque, 6,500 RPM)</b>										
C40RAM-MI50-180	CAT40	17.5	180	80	37	61	91	65	78	160
B40RAM-MI50-187	BT40	17.5	187	80	39	61	91	65	78	160
C50RAM-MI50-180	CAT50	26.5	180	70	39	61	91	80	78	160

\* Positioning block not included. Please refer to page 16.

\*\* ER Collets available on pages 25-28.

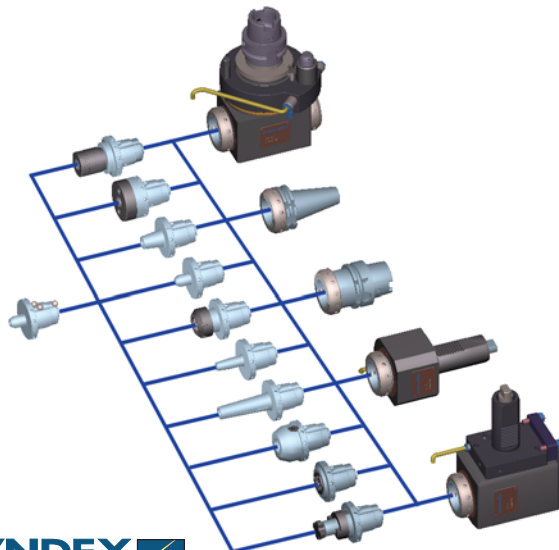

## QUICK CHANGE ANGLEHEADS™



### MODULAR TOOLHOLDERS IN DIFFERENT SIZES FOR ALL PRODUCTION AREAS:

- Tapping toolholders
- Collet toolholders (internal and external nut)
- Hydro-Flex hydraulic toolholders
- Thread tightening toolholder cutters
- Morse taper shank toolholders
- Weldon and Whistle Notch toolholders
- Shell mill toolholders

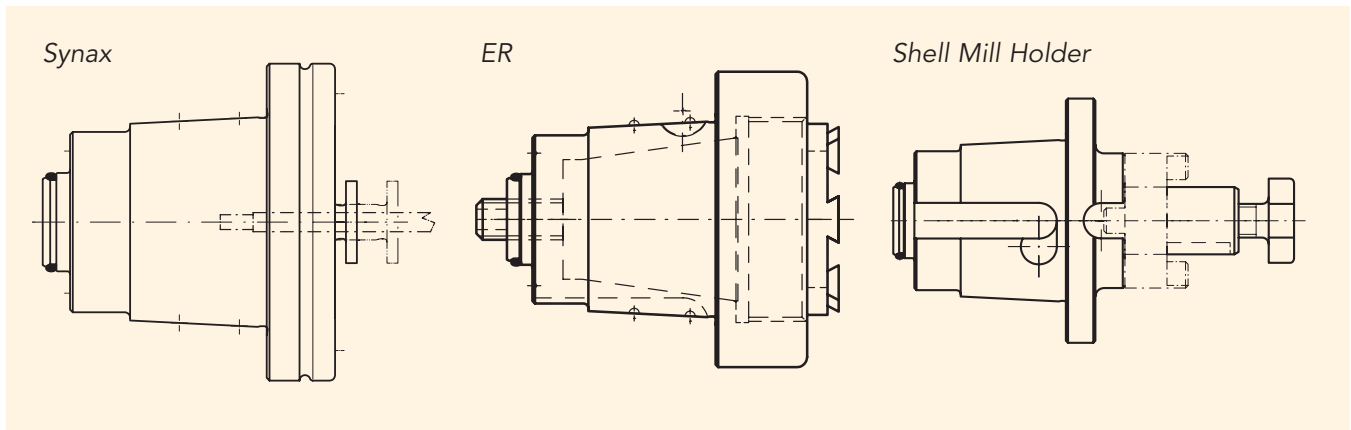

Part Number	Description
MI50-SM3/4	3/4" Shell Mill Adapter
MI50-ER25	ER25 Collet Adapter
MI50-ER32	ER32 Collet Adapter
MI50-STA-#6	#6 Synax Tap Adapter
MI50-STA-#8	#8 Synax Tap Adapter
MI50-STA-#10	#10 Synax Tap Adapter
MI50-STA-#12	#12 Synax Tap Adapter
MI50-STA-1/4	1/4 Synax Tap Adapter
MI50-STA-5/16	5/16 Synax Tap Adapter
MI50-STA-3/8	3/8 Synax Tap Adapter
MI50-STA-7/16	7/16 Synax Tap Adapter
MI50-STA-1/2	1/2 Synax Tap Adapter
MI50-STA-9/16	9/16 Synax Tap Adapter
MI50-STA-5/8	5/8 Synax Tap Adapter



# ANGLEHEADS™ Specials

## FixedAngleHeads™

The specially designed case of the FixedAngleHead ensures an accurate cutting angle without the need to adjust or verify cutting angle.

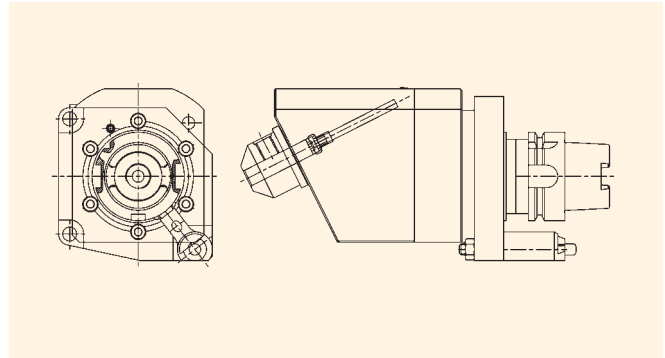
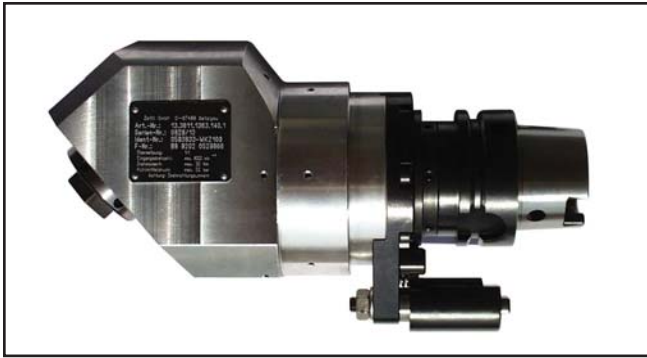

## Multi-Spindle DrillHeads™



The multi-axis positioning of the FlexHead allows total rotational and compound angle settings. Perform multiple, complex operations without costly additional work setups or fixtures.

## Special AngleHeads™



Minimized body design is suitable for machining in tight spaces.

## Applications

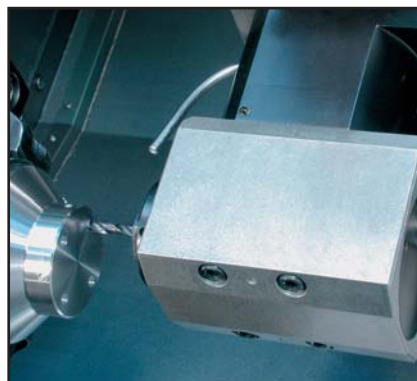

## ANGLEHEADS™ Positioning Blocks

High technology toolholders that perform beyond the main spindle's rotational characteristics, and toolholders that induce a side flow of coolant through cutting tools, require a positioning pin to operate.

This pin, which is seated into a positioning block after changing, locks the toolholder's body into a stationary position relative to the spindle face. With its body properly aligned and secured, the toolholder's internal mechanisms are ready to perform their designed operations.

Before using any of our stationary body tools, a positioning block must first be attached to the machining

center's spindle face. The block is attached to the face by utilizing the existing drilled/tapped holes on the face. Place the positioning block in a location which will assure that the positioning pin, when seated in the positioning block, will not interfere with the movements of your ATC arm or any other attachments.

All Lyndex-Nikken tools have features that allow them to be easily oriented with any position of your spindle's drive keys.

A positioning block may require slight modifications to accommodate your particular machine.

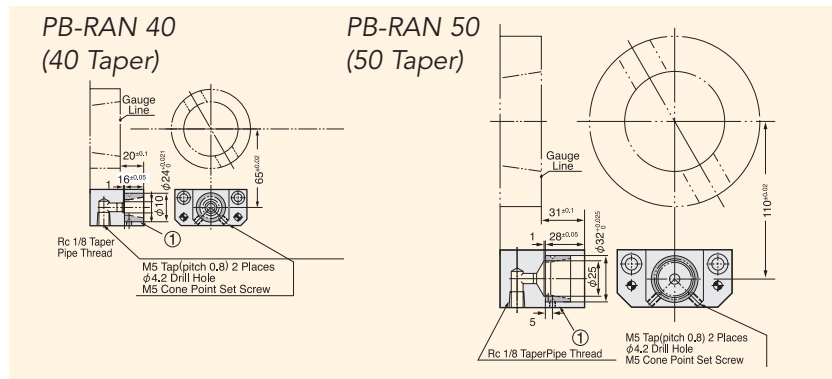
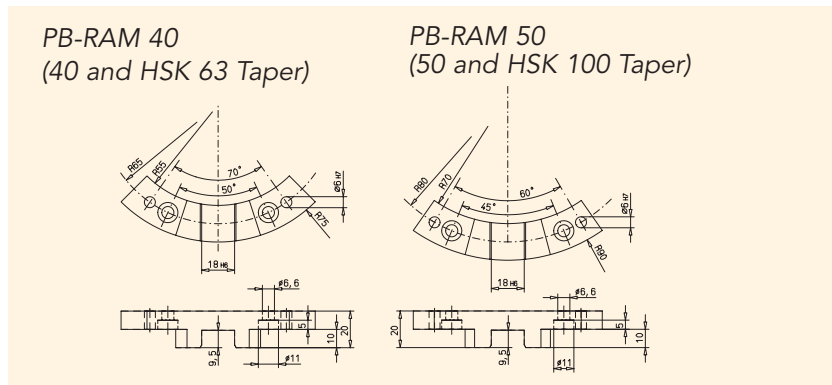

Custom stopper blocks available, including combination blocks as shown, upon special request.

## **HISPINNER™ Technical Characteristics and Features**

Lyndex-Nikken HiSpinners offer substantial increases in spindle speeds for high speed milling applications.

Our HiSpinners allow for reduced cycle times and lower per-piece costs by utilizing new high efficiency cutting tools. Cutting tool performance, in turn, is enhanced through the carried RPMs and rigidity of our HiSpinners.

Excellent accuracy, rigidity and durability are achieved through the use of our integral shank spindle, tempered and ground gears, and high precision pre-loaded spindle bearings.

- For use with all kinds of materials (HiSpinners do not require messy coolants) and applications, including drilling, milling, and grinding
- Lightweight and easy to use
- Capable of working in most ATCs
- Accuracy of .01 mm or better
- Some models available with coolant-through

### **Decrease Costs and Increase Speed**

HiSpinners increase your tooling RPMs up to 10 times faster (up to 40,000 RPM), enabling you to reduce your cycle times and per-piece costs with your current machines. Minimize spindle wear, letting the tool do the work.

### **Achieve Higher Speeds Without Heat**

HiSpinners maintain a comfortable operating temperature without the need of forced air or coolants.

### **Highly Accurate**

A main spindle supported at four points by high precision (P4 grade) bearings, ensure smooth, precise rotation and increased surface finish quality.

### **Durable**

HiSpinner bearings and gear chamber are isolated from contamination by specially designed seals.



### **Positioning Pins**

High technology toolholders that perform beyond the main spindle's rotational characteristics, and toolholders that induce a side flow of coolant through cutting tools, require a positioning pin to operate.

This pin, which is seated into a positioning block after changing, locks the toolholder's body into a stationary position relative to the spindle face. With its body properly aligned and secured, the toolholder's internal mechanisms are ready to perform their designed operations.

A positioning block may require slight modifications to accommodate your particular machine.

## NIKKEN STANDARD HISPINNER™



### Features

- Ideal for drilling, gun-drilling and milling operations
- Maximum speed: 20,000 RPM
- Gear ratio: 5:1
- Stable runout accuracy due to TiN bearing nut
- NMTB units are available upon request
- Wrenches are included

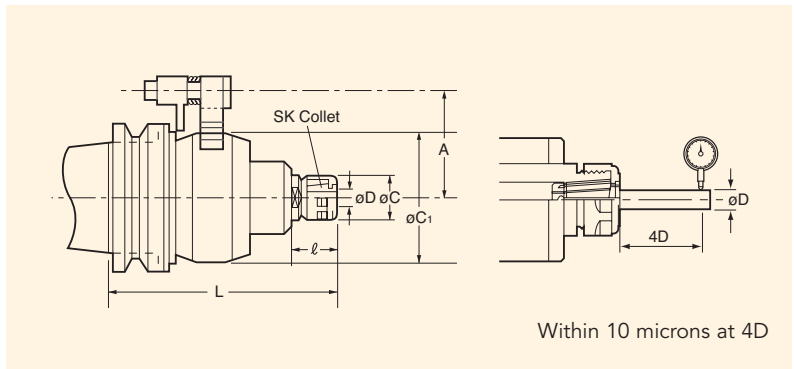

Part Number	Taper	Weight (lbs.)	D	L	C	C <sub>1</sub>	l	A	Max-RPM
<b>Collet Series - SK10</b>									
CAT40-NX5-153	CAT40	11	1.75~10	153	27.5	85	32	60	20,000
BT40-NX5-153	BT40								
CAT50-NX5-151	CAT50	15	1.75~10	151	27.5	85	46	82	20,000

\* Positioning block is included.

\*\* SK10 Collets available on page 29.

### Positioning Block

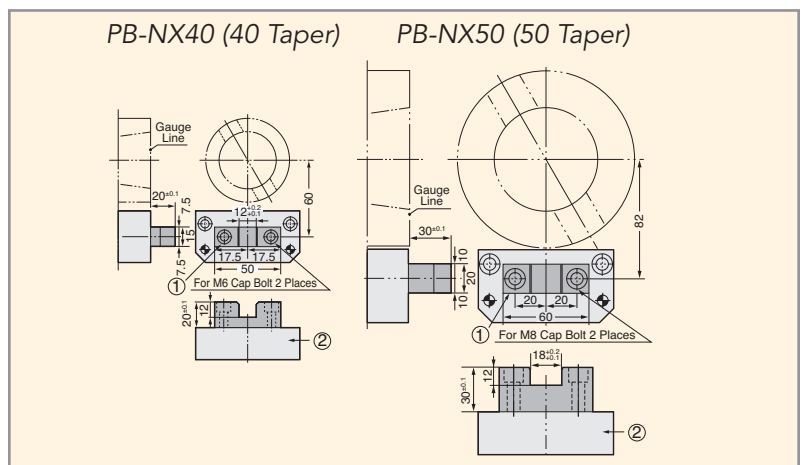

## ADVANCED HISPINNER™



### Features

- Developed especially for finish
- Tempered and ground gears
- Four pre-loaded spindle bearings
- Dust protection
- Up to 36,000 rpm
- Gear ratio: 10:1
- Wrenches are included
- 35, 45 and HSK taper available as special quote

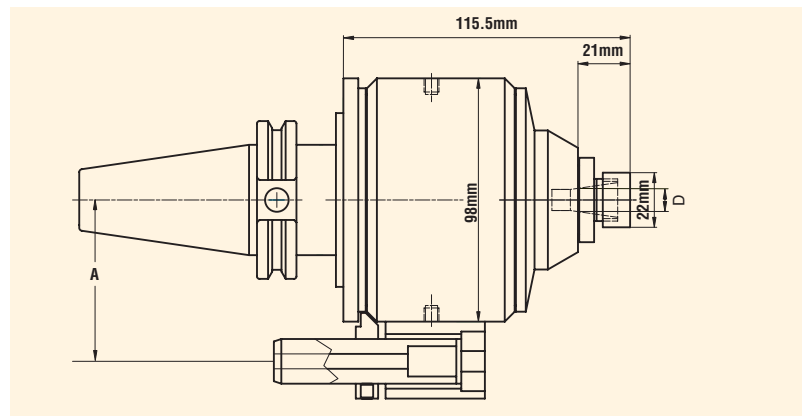

Part Number	Taper	A	Weight (lbs.)	D	Max-RPM
C40HSP-ETS14-115	CAT40	65	11	0.5-8 mm	36,000
C50HSP-ETS14-115	CAT50	80	16	0.5-8 mm	36,000
B40HSP-ETS14-115	BT40	65	12	0.5-8 mm	36,000

\* Positioning block not included.

\*\* ETS14 Collets available on page 31.

### Positioning Block

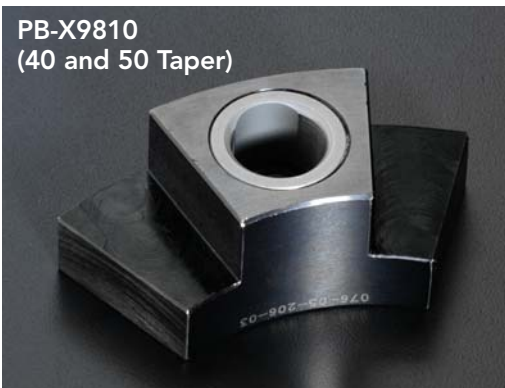

PB-X9810  
(40 and 50 Taper)

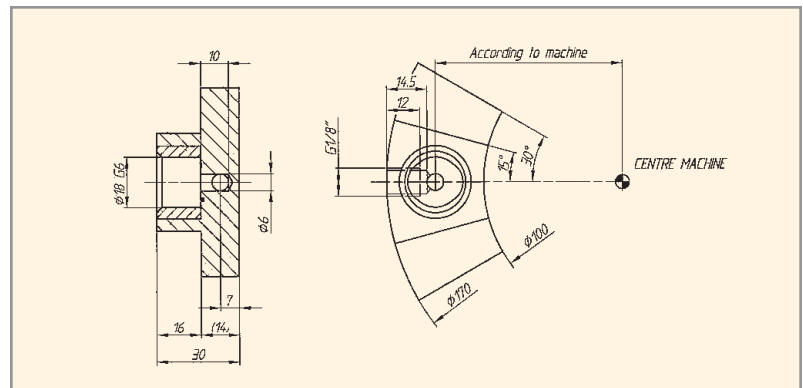

## ***Nikken FLUIDHEADS™ Features***



### ***Prolonged Tool Life***

Cutting tool life is increased by coolant being directly applied to the cutting edge. Direct coolant prevents brazed tool breakage by reducing the heat factor.

### ***Improved Holemaking***

Lyndex FluidHeads facilitate hole drilling by delivering coolant to the point of contact. The drilling-associated heat factor is eliminated, so there is no heat-related warping. In addition, chips are immediately evacuated to prevent chips from annealing to the cutting tool and the workpiece wall.

### ***Greater Feeds and Speeds***

Direct coolant applied to the tool's cutting edge provides lubrication, promotes superior chip breakage and evacuation, and prevents double-cutting of chips. These factors allow for greater feeds and speeds, increasing productivity.

### ***Advanced Multi-Seal Construction***

Lyndex FluidHeads unique multi-seal construction incorporates a series of O-rings, labyrinth and synthetic seals, and sealed high-speed roller bearings to provide precise trouble-free operation. They also feature our tough corrosion-resistant surface treatment to assure a long life.

### ***Quick and Simple Setup***

Lyndex provides you with a vernier scale for ease of orientation. Vernier scales help to orient the positioning pin and drive key slots (0-360°) to match your machining center's spindle and automatic tool changer configuration. The adjustable positioning pin will also allow you to easily adjust the height to eliminate most variances in distance between the spindle's face and positioning pin.

Special orders are available upon request.

# Nikken FLUIDHEADS™ Technical Characteristics and Stopper Blocks

## One-Touch Internal/External Coolant Feed Conversion

The oil holder drill performs internal coolant delivery, while multiple external nozzles apply jet streams of coolant directly to the cutting area. When drilling, end milling, tapping or reaming without the oil hole, switching from internal to external coolant delivery can be done in one touch.

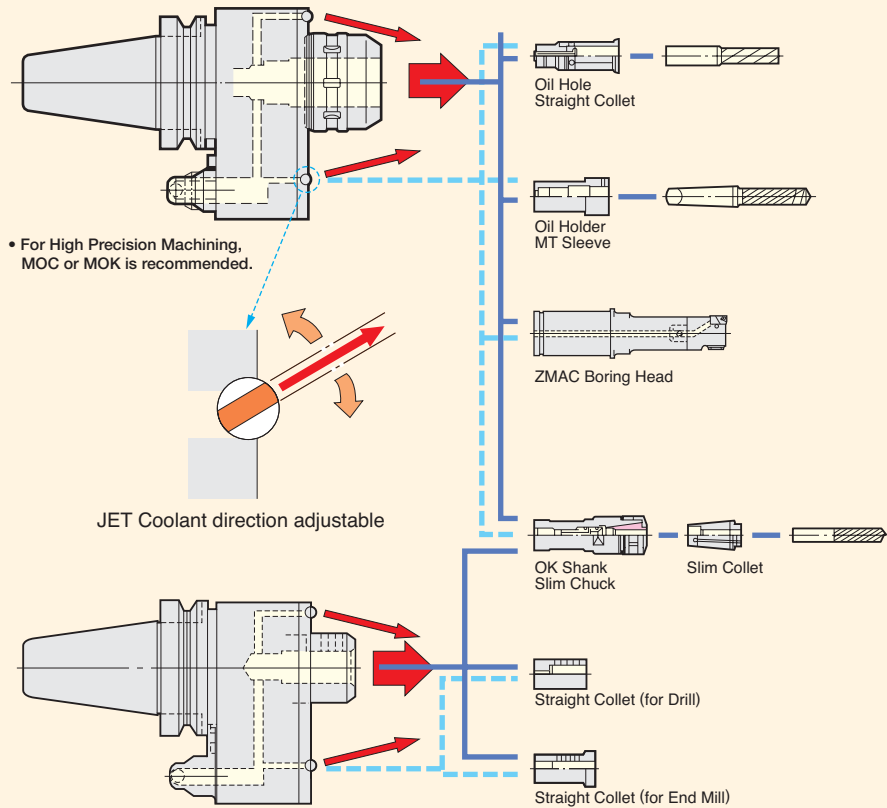

## Stopper Block

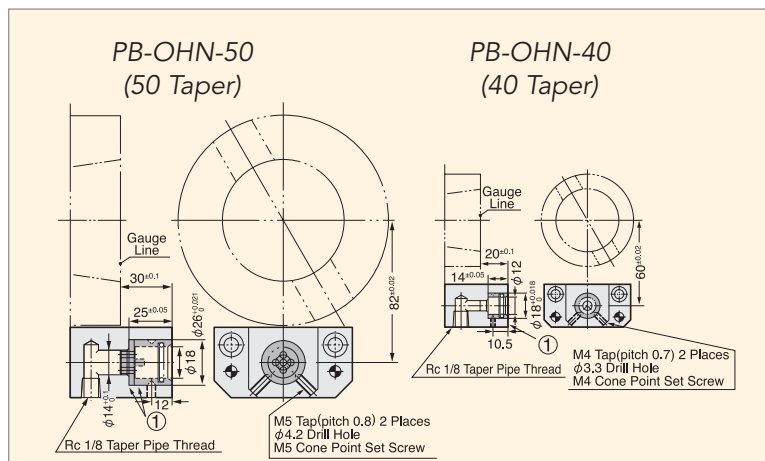

## NIKKEN SIDE LOCK FLUIDHEADS™



### Features

- Extends tool life
- Allows greater feeds and speeds
- Increases chip removal by delivering coolant at up to 400 PSI (maximum)
- Superb with indexable end mills and drills
- Compatible with most Automatic Tool Changers (ATCs)
- Set screw type holder uses reduction bushings to allow smaller sizes
- Two options for coolant flow
- Wrenches are included

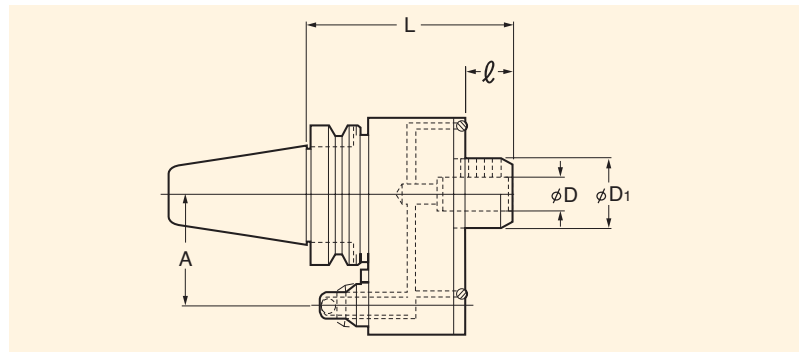

Part Number	Taper	Weight (lbs.)	D	L	A	l	D1	Max-RPM
BT40-MOL5/8-130	BT40	7	5/8	5.118	60	1.339	1.358	5,500
BT40-MOL3/4-130	BT40	8	3/4	5.118	60	1.339	1.732	4,000
BT40-MOL1-130	BT40	8	1	5.118	60	1.339	1.732	4,000
BT40-MOL1.1/4-135	BT40	9	1-1/4	5.315	60	1.535	1.929	3,500
BT50-MOL5/8-150	BT50	16	5/8	5.906	82	1.339	1.358	5,500
BT50-MOL3/4-150	BT50	17	3/4	5.906	82	1.339	1.732	4,000
BT50-MOL1-150	BT50	17	1	5.906	82	1.339	1.732	4,000
BT50-MOL1.1/4-150	BT50	17	1-1/4	5.906	82	1.535	1.929	3,500
BT50-MOL1.1/2-160	BT50	18	1-1/2	6.299	82	1.732	2.323	3,000
CAT40-MOL5/8-140	CAT40	7	5/8	5.511	60	1.339	1.358	5,500
CAT40-MOL3/4-140	CAT40	8	3/4	5.511	60	1.339	1.732	4,000
CAT40-MOL1-140	CAT40	8	1	5.511	60	1.339	1.732	4,000
CAT40-MOL1.1/4-145	CAT40	9	1-1/4	5.709	60	1.535	1.929	3,500
CAT50-MOL5/8-150	CAT50	16	5/8	5.906	82	1.339	1.358	5,500
CAT50-MOL3/4-150	CAT50	17	3/4	5.906	82	1.339	1.732	4,000
CAT50-MOL1-150	CAT50	17	1	5.906	82	1.339	1.732	4,000
CAT50-MOL1.1/4-150	CAT50	17	1-1/4	5.906	82	1.535	1.929	3,500
CAT50-MOL1.1/2-160	CAT50	18	1-1/2	6.299	82	1.732	2.323	3,000

\* Positioning block not included. Please refer to page 21.



**NIKKEN SK FLUIDHEADS™**



**Features**

- Increases hole accuracy and extends tool life
- Allows greater feeds and speeds
- Increases chip removal by delivering coolant at up to 400 PSI (maximum)
- Superb with carbide drills and gun drills
- Compatible with most Automatic Tool Changers (ATCs)
- Slim chuck type collet system
- Greater flexibility through use of collets
- Two options for coolant flow
- Wrenches are included

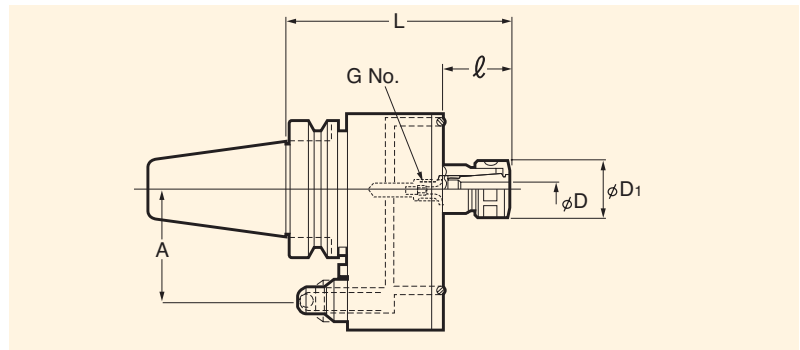

Part Number	Taper	Weight (lbs.)	D	L	A	l	D1	Max-RPM	Collet Series
BT40-MOK10-135	BT40	7	0.197 - 0.393	5.315	60	1.535	1.082	6,000	SK10
BT40-MOK16-150	BT40	8	0.393 - 0.629	5.906	60	2.125	1.575	5,500	SK16
BT50-MOK10-150	BT50	15	0.197 - 0.393	5.906	82	1.338	1.082	6,000	SK10
BT50-MOK16-165	BT50	17	0.393 - 0.629	6.496	82	1.929	1.575	5,500	SK16
CAT40-MOK10-145	CAT40	7	0.197 - 0.393	5.709	60	1.535	1.082	6,000	SK10
CAT40-MOK16-160	CAT40	8	0.393 - 0.629	6.299	60	2.125	1.575	5,500	SK16
CAT50-MOK10-150	CAT50	15	0.197 - 0.393	5.906	82	1.338	1.082	6,000	SK10
CAT50-MOK16-165	CAT50	17	0.393 - 0.629	6.496	82	1.929	1.575	5,500	SK16

\* SK Collets available on pages 29-30.

\*\* Positioning block not included. Please refer to page 21.

**NIKKEN ULTRA LOCK FLUIDHEADS™**



**Features**

- Increases hole accuracy and extends tool life
- Allows greater feeds and speeds
- Increases chip removal by delivering coolant at up to 400 PSI (maximum)
- Superb with carbide and brazed drills
- Compatible with most Automatic Tool Changers (ATCs)
- High rigidity, gripping power and accuracy
- Two options for coolant flow
- Wrenches are included

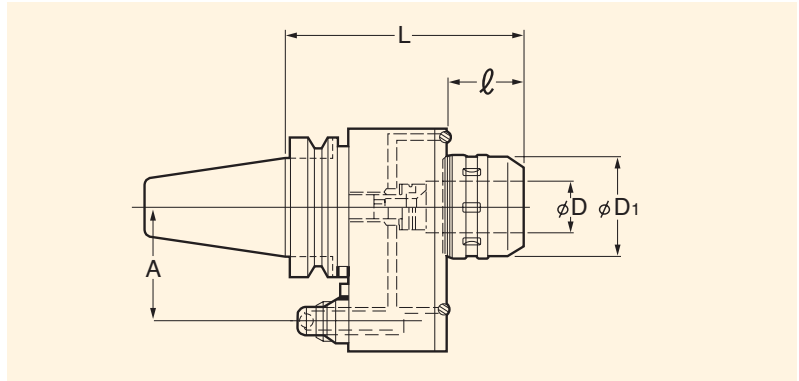

Part Number	Taper	Weight (lbs.)	D	L	A	ℓ	D1	Max-RPM	Collet Series
BT40-MOC3/4-145	BT40	8	3/4	5.709	60	1.929	2.047	4,000	CCK3/4
BT40-MOC1.1/4-160	BT40	10	1-1/4	6.299	60	2.716	2.716	3,500	CCK1.1/4
BT50-MOC3/4-160	BT50	16	3/4	6.299	82	1.732	2.047	4,000	CCK3/4
BT50-MOC1.1/4-170	BT50	16	1-1/4	6.693	82	2.212	2.716	3,500	CCK1.1/4
CAT40-MOC3/4-155	CAT40	8	3/4	6.102	60	1.929	2.047	4,000	CCK3/4
CAT40-MOC1.1/4-170	CAT40	10	1-1/4	6.693	60	2.716	2.716	3,500	CCK1.1/4
CAT50-MOC3/4-160	CAT50	16	3/4	6.299	82	1.732	2.047	4,000	CCK3/4
CAT50-MOC1.1/4-170	CAT50	16	1-1/4	6.693	82	2.212	2.716	3,500	CCK1.1/4

\* CCK Collets available on page 32.

\*\* Positioning block not included. Please refer to page 21.

# ANGLEHEADS™ ER Collets (Inch)

Part Number	Size	Collapse range
E11-002	1/32"	.031-.027
E11-003	3/64"	.047-.031
E11-004	1/16"	.063-.047
E11-005	5/64"	.078-.063
E11-006	3/32"	.094-.078
E11-007	7/64"	.109-.094
E11-008	1/8"	.125-.109
E11-009	9/64"	.141-.125
E11-010	5/32"	.156-.141
E11-011	11/64"	.172-.156
E11-012	3/16"	.187-.172
E11-013	13/64"	.203-.187
E11-014	7/32"	.219-.203
E11-015	15/64"	.234-.219
E11-016	1/4"	.250-.234
E11-017	17/64"	.266-.250
E11-14S	14 Piece Set	(1/16" - 1/4" by 64ths)
E16-002	1/32"	.031-.027
E16-004	1/16"	.063-.047
E16-006	3/32"	.094-.078
E16-008	1/8"	.125-.109
E16-010	5/32"	.156-.125
E16-012	3/16"	.187-.156
E16-014	7/32"	.219-.187
E16-016	1/4"	.250-.219
E16-018	9/32"	.281-.250
E16-020	5/16"	.312-.281
E16-022	11/32"	.344-.312
E16-024	3/8"	.375-.344
E16-026	13/32"	.406-.375
E16-12S	12 Piece Set	(1/32" - 13/32" by 32nds)
E20-004	1/16"	.063-.047
E20-006	3/32"	.094-.078
E20-008	1/8"	.125-.109
E20-010	5/32"	.156-.125
E20-012	3/16"	.187-.156
E20-014	7/32"	.219-.187
E20-016	1/4"	.250-.219
E20-018	9/32"	.281-.250
E20-020	5/16"	.312-.281
E20-022	11/32"	.344-.312
E20-024	3/8"	.375-.344
E20-026	13/32"	.406-.375
E20-028	7/16"	.437-.406
E20-030	15/32"	.469-.437
E20-032	1/2"	.500-.469
E20-15S	15 Piece Set	(1/16" - 1/2" by 32nds)
E25-004	1/16"	.063-.047
E25-006	3/32"	.094-.078
E25-008	1/8"	.125-.109
E25-010	5/32"	.156-.125
E25-012	3/16"	.187-.156
E25-014	7/32"	.219-.187
E25-016	1/4"	.250-.219
E25-018	9/32"	.281-.250
E25-020	5/16"	.312-.281
E25-022	11/32"	.344-.312
E25-024	3/8"	.375-.344
E25-026	13/32"	.406-.375

Part Number	Size	Collapse range
E25-028	7/16"	.437-.406
E25-030	15/32"	.469-.437
E25-032	1/2"	.500-.469
E25-034	17/32"	.531-.500
E25-036	9/16"	.563-.531
E25-038	19/32"	.594-.563
E25-040	5/8"	.625-.594
E25-19S	19 Piece Set	(1/16" - 5/8" by 32nds)
E32-008	1/8"	.125-.109
E32-010	5/32"	.156-.125
E32-012	3/16"	.187-.156
E32-014	7/32"	.219-.187
E32-016	1/4"	.250-.219
E32-018	9/32"	.281-.250
E32-020	5/16"	.312-.281
E32-022	11/32"	.344-.312
E32-024	3/8"	.375-.344
E32-026	13/32"	.406-.375
E32-028	7/16"	.437-.406
E32-030	15/32"	.469-.437
E32-032	1/2"	.500-.469
E32-034	17/32"	.531-.500
E32-036	9/16"	.563-.531
E32-038	19/32"	.594-.563
E32-040	5/8"	.625-.594
E32-042	21/32"	.656-.625
E32-044	11/16"	.688-.656
E32-046	23/32"	.719-.688
E32-048	3/4"	.750-.719
E32-050	25/32"	.781-.750
E32-21S	21 Piece Set	(1/8" - 3/4" by 32nds)
E40-010	5/32"	.156-.125
E40-012	3/16"	.187-.156
E40-014	7/32"	.219-.187
E40-016	1/4"	.250-.219
E40-018	9/32"	.281-.250
E40-020	5/16"	.312-.281
E40-022	11/32"	.344-.312
E40-024	3/8"	.375-.344
E40-026	13/32"	.406-.375
E40-028	7/16"	.437-.406
E40-030	15/32"	.469-.437
E40-032	1/2"	.500-.469
E40-034	17/32"	.531-.500
E40-036	9/16"	.563-.531
E40-038	19/32"	.594-.563
E40-040	5/8"	.625-.594
E40-042	21/32"	.656-.625
E40-044	11/16"	.688-.656
E40-046	23/32"	.719-.688
E40-048	3/4"	.750-.719
E40-050	25/32"	.781-.750
E40-052	13/16"	.813-.781
E40-054	27/32"	.844-.813
E40-056	7/8"	.875-.844
E40-058	29/32"	.906-.875
E40-060	15/16"	.938-.906
E40-062	31/32"	.969-.938
E40-064	1"	1.000-.969
E40-25S	25 Piece Set	(1/4" - 1" by 32nds)

# ANGLEHEADS™ ER Collets (Metric)

Part Number	Size	Collapse range
E11-039	1.0mm	.039-.019
E11-059	1.5mm	.059-.039
E11-078	2.0mm	.078-.059
E11-098	2.5mm	.098-.078
E11-118	3.0mm	.118-.098
E11-137	3.5mm	.137-.118
E11-157	4.0mm	.157-.137
E11-177	4.5mm	.177-.157
E11-196	5.0mm	.196-.177
E11-216	5.5mm	.216-.196
E11-236	6.0mm	.236-.216
E11-255	6.5mm	.255-.236
E11-275	7.0mm	.275-.255
E11-12S	12 Piece Set	1.0mm - 7.0mm by 0.5mm
E16-039	1.0mm	.039-.019
E16-059	1.5mm	.059-.039
E16-078	2.0mm	.078-.059
E16-098	2.5mm	.098-.078
E16-118	3.0mm	.118-.098
E16-137	3.5mm	.137-.118
E16-157	4.0mm	.157-.118
E16-177	4.5mm	.177-.137
E16-196	5.0mm	.196-.157
E16-216	5.5mm	.216-.177
E16-236	6.0mm	.236-.196
E16-255	6.5mm	.255-.216
E16-275	7.0mm	.275-.236
E16-295	7.5mm	.295-.255
E16-314	8.0mm	.314-.275
E16-334	8.5mm	.334-.295
E16-354	9.0mm	.354-.314
E16-374	9.5mm	.374-.332
E16-393	10.0mm	.393-.354
E16-09S	9 Piece Set	1.0mm - 10.0mm by 1.0mm
E20-078	2.0mm	.078-.059
E20-118	3.0mm	.118-.098
E20-137	3.5mm	.137-.118
E20-157	4.0mm	.157-.118
E20-196	5.0mm	.196-.157
E20-236	6.0mm	.236-.196
E20-275	7.0mm	.275-.236
E20-314	8.0mm	.314-.275
E20-354	9.0mm	.354-.314
E20-393	10.0mm	.393-.354
E20-433	11.0mm	.433-.393
E20-452	11.5mm	.452-.433
E20-472	12.0mm	.472-.433
E20-511	13.0mm	.511-.472
E20-11S	11 Piece Set	2.0mm - 13.0mm by 1.0mm
E25-078	2.0mm	.078-.059
E25-118	3.0mm	.118-.098
E25-137	3.5mm	.137-.118
E25-157	4.0mm	.157-.118
E25-196	5.0mm	.196-.157
E25-236	6.0mm	.236-.196
E25-275	7.0mm	.275-.236
E25-314	8.0mm	.314-.275

Part Number	Size	Collapse range
E25-354	9.0mm	.354-.314
E25-393	10.0mm	.393-.354
E25-433	11.0mm	.433-.393
E25-452	11.5mm	.452-.433
E25-472	12.0mm	.472-.433
E25-511	13.0mm	.511-.472
E25-551	14.0mm	.551-.511
E25-590	15.0mm	.590-.551
E25-629	16.0mm	.629-.590
E25-14S	14 Piece Set	2.0mm - 16.0mm by 1.0mm
E32-118	3.0mm	.118-.098
E32-137	3.5mm	.137-.118
E32-157	4.0mm	.157-.118
E32-196	5.0mm	.196-.157
E32-236	6.0mm	.236-.196
E32-275	7.0mm	.275-.236
E32-314	8.0mm	.314-.275
E32-354	9.0mm	.354-.314
E32-393	10.0mm	.393-.354
E32-433	11.0mm	.433-.393
E32-452	11.5mm	.452-.413
E32-472	12.0mm	.472-.433
E32-511	13.0mm	.511-.472
E32-551	14.0mm	.551-.511
E32-590	15.0mm	.590-.551
E32-629	16.0mm	.629-.590
E32-669	17.0mm	.669-.629
E32-708	18.0mm	.708-.669
E32-748	19.0mm	.748-.708
E32-767	19.5mm	.767-.728
E32-787	20.0mm	.787-.748
E32-18S	18 Piece Set	2.0mm - 20.0mm by 1.0mm
E40-157	4.0mm	.157-.118
E40-196	5.0mm	.196-.157
E40-236	6.0mm	.236-.196
E40-275	7.0mm	.275-.236
E40-314	8.0mm	.314-.275
E40-354	9.0mm	.354-.314
E40-393	10.0mm	.393-.354
E40-433	11.0mm	.433-.393
E40-452	11.5mm	.452-.413
E40-472	12.0mm	.472-.433
E40-511	13.0mm	.511-.472
E40-551	14.0mm	.551-.511
E40-590	15.0mm	.590-.551
E40-629	16.0mm	.629-.590
E40-669	17.0mm	.669-.629
E40-708	18.0mm	.708-.669
E40-748	19.0mm	.748-.708
E40-767	19.5mm	.767-.728
E40-787	20.0mm	.787-.748
E40-826	21.0mm	.826-.787
E40-866	22.0mm	.866-.826
E40-905	23.0mm	.905-.866
E40-944	24.0mm	.944-.905
E40-984	25.0mm	.984-.944
E40-1023	26.0mm	1.023-.984
E40-23S	23 Piece Set	4.0mm - 26.0mm by 1.0mm

# ANGLEHEADS™ ER Coolant Collets (Inch)

Part Number	Size	Collapse range
E11-012(C)	3/16"	.187-.183
E11-013(C)	13/64"	.203-.199
E11-014(C)	7/32"	.218-.214
E11-015(C)	15/64"	.234-.230
E11-016(C)	1/4"	.250-.246
E11-017(C)	17/64"	.265-.261
E11-6S(C)	6 Piece Set	(3/16" - 17/64" by 64ths)
E16-006(C)	3/32"	.094-.089
E16-007(C)	7/64"	.109-.105
E16-008(C)	1/8"	.125-.121
E16-009(C)	9/64"	.140-.136
E16-010(C)	5/32"	.156-.152
E16-011(C)	11/64"	.171-.167
E16-012(C)	3/16"	.187-.183
E16-013(C)	13/64"	.203-.199
E16-014(C)	7/32"	.219-.203
E16-015(C)	15/64"	.234-.219
E16-016(C)	1/4"	.250-.234
E16-017(C)	17/64"	.266-.250
E16-018(C)	9/32"	.281-.266
E16-019(C)	19/64"	.297-.281
E16-020(C)	5/16"	.312-.297
E16-021(C)	21/64"	.328-.312
E16-022(C)	11/32"	.344-.328
E16-023(C)	23/64"	.359-.344
E16-024(C)	3/8"	.375-.359
E16-025(C)	25/64"	.391-.375
E16-026(C)	13/32"	.406-.391
E16-11S(C)	11 Piece Set	(3/32" - 13/32" by 32nds)
E20-010(C)	5/32"	.156-.152
E20-011(C)	11/64"	.172-.167
E20-012(C)	3/16"	.187-.183
E20-013(C)	13/64"	.203-.199
E20-014(C)	7/32"	.219-.203
E20-015(C)	15/64"	.234-.219
E20-016(C)	1/4"	.250-.234
E20-017(C)	17/64"	.266-.250
E20-018(C)	9/32"	.281-.266
E20-019(C)	19/64"	.297-.281
E20-020(C)	5/16"	.312-.297
E20-021(C)	21/64"	.328-.312
E20-022(C)	11/32"	.344-.328
E20-023(C)	23/64"	.359-.344
E20-024(C)	3/8"	.375-.359
E20-025(C)	25/64"	.391-.375
E20-026(C)	13/32"	.406-.391
E20-027(C)	27/64"	.422-.406
E20-028(C)	7/16"	.437-.422
E20-029(C)	29/64"	.453-.437
E20-030(C)	15/32"	.469-.453
E20-031(C)	31/64"	.484-.469
E20-032(C)	1/2"	.500-.484
E20-12S(C)	12 Piece Set	(5/32" - 1/2" by 32nds)
E25-014(C)	7/32"	.219-.203
E25-015(C)	15/64"	.234-.219
E25-016(C)	1/4"	.250-.234
E25-017(C)	17/64"	.266-.250
E25-018(C)	9/32"	.281-.266
E25-019(C)	19/64"	.297-.281
E25-020(C)	5/16"	.312-.297
E25-021(C)	21/64"	.328-.312

Part Number	Size	Collapse range
E25-022(C)	11/32"	.344-.328
E25-023(C)	23/64"	.359-.344
E25-024(C)	3/8"	.375-.359
E25-025(C)	25/64"	.391-.375
E25-026(C)	13/32"	.406-.391
E25-027(C)	27/64"	.422-.406
E25-028(C)	7/16"	.437-.422
E25-029(C)	29/64"	.453-.437
E25-030(C)	15/32"	.469-.453
E25-031(C)	31/64"	.484-.469
E25-032(C)	1/2"	.500-.484
E25-033(C)	33/64"	.516-.500
E25-034(C)	17/32"	.531-.516
E25-035(C)	35/64"	.547-.531
E25-036(C)	9/16"	.563-.547
E25-037(C)	37/64"	.578-.563
E25-038(C)	19/32"	.594-.578
E25-039(C)	39/64"	.609-.594
E25-040(C)	5/8"	.625-.609
E25-13S(C)	13 Piece Set	(1/4" - 5/8" by 32nds)
E32-016(C)	1/4"	.250-.234
E32-017(C)	17/64"	.266-.250
E32-018(C)	9/32"	.281-.266
E32-019(C)	19/64"	.297-.281
E32-020(C)	5/16"	.312-.297
E32-021(C)	21/64"	.328-.312
E32-022(C)	11/32"	.344-.328
E32-023(C)	23/64"	.359-.344
E32-024(C)	3/8"	.375-.359
E32-025(C)	25/64"	.391-.375
E32-026(C)	13/32"	.406-.391
E32-027(C)	27/64"	.422-.406
E32-028(C)	7/16"	.437-.422
E32-029(C)	29/64"	.453-.437
E32-030(C)	15/32"	.469-.453
E32-031(C)	31/64"	.484-.469
E32-032(C)	1/2"	.500-.484
E32-033(C)	33/64"	.516-.500
E32-034(C)	17/32"	.531-.516
E32-035(C)	35/64"	.547-.531
E32-036(C)	9/16"	.563-.547
E32-037(C)	37/64"	.578-.563
E32-038(C)	19/32"	.594-.578
E32-039(C)	39/64"	.609-.594
E32-040(C)	5/8"	.625-.609
E32-041(C)	41/64"	.641-.625
E32-042(C)	21/32"	.656-.641
E32-043(C)	43/64"	.672-.656
E32-044(C)	11/16"	.688-.672
E32-045(C)	45/64"	.703-.688
E32-046(C)	23/32"	.719-.703
E32-047(C)	47/64"	.734-.719
E32-048(C)	3/4"	.750-.734
E32-049(C)	49/64"	.766-.750
E32-050(C)	25/32"	.781-.766
E32-17S(C)	17 Piece Set	(1/4" - 3/4" by 32nds)
E40-020(C)	5/16"	.312-.297
E40-024(C)	3/8"	.375-.359
E40-028(C)	7/16"	.437-.422
E40-032(C)	1/2"	.500-.484
E40-036(C)	9/16"	.563-.547
E40-040(C)	5/8"	.625-.609

# ANGLEHEADS™ ER Coolant Collets (Metric)

Part Number	Size	Collapse range
E11-157(C)	4.0mm	.157-.153
E11-177(C)	4.5mm	.177-.173
E11-196(C)	5.0mm	.196-.192
E11-216(C)	5.5mm	.216-.212
E11-236(C)	6.0mm	.236-.232
E11-255(C)	6.5mm	.255-.251
E11-275(C)	7.0mm	.275-.271
E11-7S(C)	7 Piece Set	3.9mm - 7.0mm by 0.5mm
E16-157(C)	4.0mm	.157-.153
E16-177(C)	4.5mm	.177-.173
E16-196(C)	5.0mm	.196-.192
E16-216(C)	5.5mm	.216-.212
E16-236(C)	6.0mm	.236-.216
E16-255(C)	6.5mm	.255-.236
E16-275(C)	7.0mm	.275-.255
E16-295(C)	7.5mm	.295-.275
E16-314(C)	8.0mm	.314-.295
E16-334(C)	8.5mm	.334-.314
E16-354(C)	9.0mm	.354-.334
E16-374(C)	9.5mm	.374-.354
E16-393(C)	10.0mm	.393-.374
E16-13S(C)	13 Piece Set	4.0mm - 10.0mm by 0.5mm
E20-196(C)	5.0mm	.196-.192
E20-216(C)	5.5mm	.216-.212
E20-236(C)	6.0mm	.236-.216
E20-255(C)	6.5mm	.255-.236
E20-275(C)	7.0mm	.275-.255
E20-295(C)	7.5mm	.295-.275
E20-314(C)	8.0mm	.314-.295
E20-334(C)	8.5mm	.334-.314
E20-354(C)	9.0mm	.354-.334
E20-374(C)	9.5mm	.374-.354
E20-393(C)	10.0mm	.393-.374
E20-413(C)	10.5mm	.413-.393
E20-433(C)	11.0mm	.433-.413
E20-452(C)	11.5mm	.452-.433
E20-472(C)	12.0mm	.472-.452
E20-492(C)	12.5mm	.492-.472
E20-511(C)	13.0mm	.511-.492
E20-17S(C)	17 Piece Set	5.0mm - 13.0mm by 0.5mm
E25-236(C)	6.0mm	.236-.217
E25-255(C)	6.5mm	.255-.236
E25-275(C)	7.0mm	.275-.255
E25-295(C)	7.5mm	.295-.275
E25-314(C)	8.0mm	.314-.295
E25-334(C)	8.5mm	.334-.314
E25-354(C)	9.0mm	.354-.334
E25-374(C)	9.5mm	.374-.354
E25-393(C)	10.0mm	.393-.374
E25-413(C)	10.5mm	.413-.393
E25-433(C)	11.0mm	.433-.413
E25-452(C)	11.5mm	.452-.433
E25-472(C)	12.0mm	.472-.452
E25-492(C)	12.5mm	.492-.472
E25-511(C)	13.0mm	.511-.492
E25-531(C)	13.5mm	.531-.511
E25-551(C)	14.0mm	.551-.531
E25-570(C)	14.5mm	.570-.551
E25-590(C)	15.0mm	.590-.570

Part Number	Size	Collapse range
E25-610(C)	15.5mm	.610-.590
E25-629(C)	16.0mm	.629-.610
E25-21S(C)	21 Piece Set	6.0mm - 16.0mm by 0.5mm
E32-393(C)	10.0mm	.393-.374
E32-413(C)	10.5mm	.413-.393
E32-433(C)	11.0mm	.433-.413
E32-452(C)	11.5mm	.452-.433
E32-472(C)	12.0mm	.472-.452
E32-492(C)	12.5mm	.492-.472
E32-511(C)	13.0mm	.511-.492
E32-531(C)	13.5mm	.531-.511
E32-551(C)	14.0mm	.551-.531
E32-570(C)	14.5mm	.570-.551
E32-590(C)	15.0mm	.590-.570
E32-610(C)	15.5mm	.610-.590
E32-629(C)	16.0mm	.629-.610
E32-649(C)	16.5mm	.649-.629
E32-669(C)	17.0mm	.669-.649
E32-688(C)	17.5mm	.688-.669
E32-708(C)	18.0mm	.708-.688
E32-728(C)	18.5mm	.728-.708
E32-748(C)	19.0mm	.748-.728
E32-767(C)	19.5mm	.767-.748
E32-787(C)	20.0mm	.787-.767
E32-21S(C)	21 Piece Set	10.0mm - 20.0mm by 0.5m
E40-393(C)	10.0mm	.393-.374
E40-413(C)	10.5mm	.413-.393
E40-433(C)	11.0mm	.433-.413
E40-452(C)	11.5mm	.452-.433
E40-472(C)	12.0mm	.472-.452
E40-492(C)	12.5mm	.492-.472
E40-511(C)	13.0mm	.511-.492
E40-531(C)	13.5mm	.531-.511
E40-551(C)	14.0mm	.551-.531
E40-570(C)	14.5mm	.570-.551
E40-590(C)	15.0mm	.590-.570
E40-610(C)	15.5mm	.610-.590
E40-629(C)	16.0mm	.629-.610
E40-649(C)	16.5mm	.649-.629
E40-669(C)	17.0mm	.669-.649
E40-688(C)	17.5mm	.688-.669
E40-708(C)	18.0mm	.708-.688
E40-728(C)	18.5mm	.728-.708
E40-748(C)	19.0mm	.748-.728
E40-767(C)	19.5mm	.767-.748
E40-787(C)	20.0mm	.807-.767
E40-807(C)	20.5mm	.807-.787
E40-826(C)	21.0mm	.826-.807
E40-846(C)	21.5mm	.846-.826
E40-866(C)	22.0mm	.866-.846
E40-885(C)	22.5mm	.885-.866
E40-905(C)	23.0mm	.905-.885
E40-925(C)	23.5mm	.925-.905
E40-944(C)	24.0mm	.944-.925
E40-964(C)	24.5mm	.964-.944
E40-984(C)	25.0mm	.984-.964
E40-1003(C)	25.5mm	1.003-.984
E40-1023(C)	26.0mm	1.023-1.003
E40-33S(C)	33 Piece Set	10.0mm - 26.0mm by 0.5mm



**SK10 COLLETS (inch)**

Part Number	Size
SK10-1/8A	0.125
SK10-3/16A	0.187
SK10-1/4A	0.250
SK10-5/16A	0.312
SK10-3/8A	0.375

**SK10 COLLETS (metric)**

Part Number	Size Range mm	Size Range Inch
SK10-2	1.75-2.0mm	.068-.078
SK10-2.25	2.0-2.25mm	.078-.088
SK10-2.5	2.25-2.5mm	.088-.098
SK10-2.75	2.5-2.75mm	.098-.108
SK10-3	2.75-3.0mm	.108-.118
SK10-3.5	3.0-3.5mm	.118-.137
SK10-4	3.5-4.0mm	.137-.157
SK10-4.5	4.0-4.5mm	.157-.177
SK10-5	4.5-5.0mm	.177-.196
SK10-5.5	5.0-5.5mm	.196-.216
SK10-6	5.5-6.0mm	.216-.236
SK10-6.5	6.0-6.5mm	.236-.255
SK10-7	6.5-7.0mm	.255-.275
SK10-7.5	7.0-7.5mm	.275-.295
SK10-8	7.5-8.0mm	.295-.314
SK10-8.5	8.0-8.5mm	.314-.334
SK10-9	8.5-9.0mm	.334-.354
SK10-9.5	9.0-9.5mm	.354-.374
SK10-10	9.5-10.0mm	.374-.393
SK10-SET	19 Piece SK10 Collet Set 1.75mm - 10.0mm	



**SK16 COLLETS (inch)**

Part Number	Size
SK16-1/8A	0.125
SK16-3/16A	0.187
SK16-1/4A	0.250
SK16-5/16A	0.312
SK16-3/8A	0.375
SK16-7/16A	0.437
SK16-1/2A	0.500
SK16-9/16A	0.562
SK16-5/8A	0.625

**SK16 COLLETS (metric)**

Part Number	Size Range mm	Size Range inch
SK16-3	2.75-3.0mm	.108-.118
SK16-3.5	3.0-3.5mm	.118-.137
SK16-4	3.5-4.0mm	.137-.157
SK16-4.5	4.0-4.5mm	.157-.177
SK16-5	4.5-5.0mm	.177-.196
SK16-5.5	5.0-5.5mm	.196-.216
SK16-6	5.5-6.0mm	.216-.236
SK16-6.5	6.0-6.5mm	.236-.255
SK16-7	6.5-7.0mm	.255-.275
SK16-7.5	7.0-7.5mm	.275-.295
SK16-8	7.5-8.0mm	.295-.314
SK16-8.5	8.0-8.5mm	.314-.334
SK16-9	8.5-9.0mm	.334-.354
SK16-9.5	9.0-9.5mm	.354-.374
SK16-10	9.5-10.0mm	.374-.393
SK16-10.5	10.0-10.5mm	.393-.413
SK16-11	10.5-11.0mm	.413-.433
SK16-11.5	11.0-11.5mm	.433-.452
SK16-12	11.5-12.0mm	.452-.472
SK16-12.5	12.0-12.5mm	.472-.492
SK16-13	12.5-13.0mm	.492-.511
SK16-13.5	13.0-13.5mm	.511-.531
SK16-14	13.5-14.0mm	.531-.551
SK16-14.5	14.0-14.5mm	.551-.570
SK16-15	14.5-15.0mm	.570-.590
SK16-15.5	15.0-15.5mm	.590-.610
SK16-16	15.5-16.0mm	.610-.629
SK16-SET	27 Piece SK16 Collet Set 2.75mm - 16.0mm	

## SK™ COOLANT COLLET SYSTEM

Collet Chuck	Coolant Nut	Cutting Tool Size	Coolant-Thru Disk	Slotted Disk	Disk Wrench
SK6	SKN-6WBJ	3mm	SKJ6-3C	SKJ6-3	SKJL-6
		4mm	SKJ6-4C	SKJ6-4	
		5mm	SKJ6-5C	SKJ6-5	
		6mm	SKJ6-6C	SKJ6-6	
		1/8"	SKJ6-1/8C	SKJ6-1/8	
		3/16"	SKJ6-3/16C	SKJ6-3/16	
SK10	SKN-10BJ	3mm	SKJ10-3C	SKJ10-3	SKJL-10
		4mm	SKJ10-4C	SKJ10-4	
		5mm	SKJ10-5C	SKJ10-5	
		6mm	SKJ10-6C	SKJ10-6	
		8mm	SKJ10-8C	SKJ10-8	
		10mm	SKJ10-10C	SKJ10-10	
		1/8"	SKJ10-1/8C	SKJ10-1/8	
		3/16"	SKJ10-3/16C	SKJ10-3/16	
		1/4"	SKJ10-1/4C	SKJ10-1/4	
		5/16"	SKJ10-5/16C	SKJ10-5/16	
		3/8"	SKJ10-3/8C	SKJ10-3/8	
		SK16	SKN-16BJ	6mm	
8mm	SKJ16-8C			SKJ16-8	
10mm	SKJ16-10C			SKJ16-10	
12mm	SKJ16-12C			SKJ16-12	
16mm	SKJ16-16C			SKJ16-16	
1/4"	SKJ16-1/4C			SKJ16-1/4	
5/16"	SKJ16-5/16C			SKJ16-5/16	
3/8"	SKJ16-3/8C			SKJ16-3/8	
7/16"	SKJ16-7/16C			SKJ16-7/16	
1/2"	SKJ16-1/2C			SKJ16-1/2	
9/16"	SKJ16-9/16C			SKJ16-9/16	
5/8"	SKJ16-5/8C			SKJ16-5/8	
SK25	SKN-25BJ			16mm	SKJ25-16C
		20mm	SKJ25-20C	SKJ25-20	
		25mm	SKJ25-25C	SKJ25-25	
		5/8"	SKJ25-5/8C	SKJ25-5/8	
		11/16"	SKJ25-11/16C	SKJ25-11/16	
		3/4"	SKJ25-3/4C	SKJ25-3/4	
		13/16"	SKJ25-13/16C	SKJ25-13/16	
		7/8"	SKJ25-7/8C	SKJ25-7/8	
		15/16"	SKJ25-15/16C	SKJ25-15/16	
		1"	SKJ25-1C	SKJ25-1	

## BLANK DISKS (machinable)

Collet Chuck	Blank Disks
SK6	SKJ6-BLANK
SK10	SKJ10-BLANK
SK16	SKJ16-BLANK
SK25	SKJ25-BLANK



## KM 1-1/4 INCH COLLETS

Part Number	Size
KM1.1/4-3/16	3/16"
KM1.1/4-1/4	1/4"
KM1.1/4-5/16	5/16"
KM1.1/4-3/8	3/8"
KM1.1/4-7/16	7/16"
KM1.1/4-1/2	1/2"
KM1.1/4-9/16	9/16"
KM1.1/4-5/8	5/8"
KM1.1/4-3/4	3/4"
KM1.1/4-7/8	7/8"
KM1.1/4-1	1"

## KM 1-1/4 METRIC COLLETS

Part Number	Size
KM1.1/4-6	6mm
KM1.1/4-8	8mm
KM1.1/4-10	10mm
KM1.1/4-12	12mm
KM1.1/4-14	14mm
KM1.1/4-16	16mm
KM1.1/4-20	20mm
KM1.1/4-25	25mm

## KM 3/4 INCH COLLETS

Part Number	Size
KM3/4-1/8	1/8"
KM3/4-3/16	3/16"
KM3/4-1/4	1/4"
KM3/4-5/16	5/16"
KM3/4-3/8	3/8"
KM3/4-7/16	7/16"
KM3/4-1/2	1/2"
KM3/4-9/16	9/16"
KM3/4-5/8	5/8"

## KM 3/4 METRIC COLLETS

Part Number	Size
KM3/4-6	6mm
KM3/4-7	7mm
KM3/4-8	8mm
KM3/4-10	10mm
KM3/4-12	12mm
KM3/4-14	14mm
KM3/4-16	16mm

## ETS 14 INCH COLLETS

Part Number	Size	Collapse range
ETS14-008	1/8"	.5mm
ETS14-012	3/16"	.5mm
ETS14-016	1/4"	.5mm
ETS14-020	5/16"	.5mm

## ETS 14 METRIC COLLETS

Part Number	Size	Collapse range
ETS14-118	3.0mm	.5mm
ETS14-137	3.5mm	.5mm
ETS14-157	4.0mm	.5mm
ETS14-177	4.5mm	.5mm
ETS14-196	5.0mm	.5mm
ETS14-216	5.5mm	.5mm
ETS14-236	6.0mm	.5mm
ETS14-255	6.5mm	.5mm
ETS14-275	7.0mm	.5mm
ETS14-295	7.5mm	.5mm
ETS14-314	8.0mm	.5mm

## 3/4 INCH COOLANT THRU ACCESSORIES

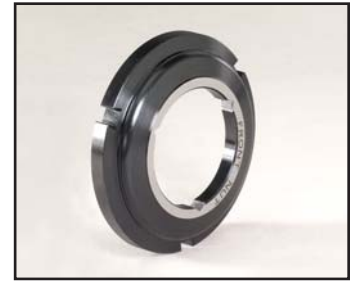

Size	Coolant Collet	Coolant-Thru Nut	Slotted Nut
1/8"	CCK3/4-1/8	CKFN3/4-1/8C	CKFN3/4-1/8
3/16"	CCK3/4-3/16	CKFN3/4-3/16C	CKFN3/4-3/16
1/4"	CCK3/4-1/4	CKFN3/4-1/4C	CKFN3/4-1/4
5/16"	CCK3/4-5/16	CKFN3/4-5/16C	CKFN3/4-5/16
3/8"	CCK3/4-3/8	CKFN3/4-3/8C	CKFN3/4-3/8
7/16"	CCK3/4-7/16	CKFN3/4-7/16C	CKFN3/4-7/16
1/2"	CCK3/4-1/2	CKFN3/4-1/2C	CKFN3/4-1/2
9/16"	CCK3/4-9/16	CKFN3/4-9/16C	CKFN3/4-9/16
5/8"	CCK3/4-5/8	CKFN3/4-5/8C	CKFN3/4-5/8
6mm	CCK3/4-6	CKFN3/4-6C	CKFN3/4-6
7mm	CCK3/4-7	CKFN3/4-7C	CKFN3/4-7
8mm	CCK3/4-8	CKFN3/4-8C	CKFN3/4-8
10mm	CCK3/4-10	CKFN3/4-10C	CKFN3/4-10
12mm	CCK3/4-12	CKFN3/4-12C	CKFN3/4-12
14mm	CCK3/4-14	CKFN3/4-14C	CKFN3/4-14
16mm	CCK3/4-16	CKFN3/4-16C	CKFN3/4-16

## 1.1/4 INCH COOLANT THRU ACCESSORIES

Size	Coolant Collet	Coolant-Thru Nut	Slotted Nut
3/16"	CCK1.1/4-3/16	CKFN1.1/4-3/16C	CKFN1.1/4-3/16
1/4"	CCK1.1/4-1/4	CKFN1.1/4-1/4C	CKFN1.1/4-1/4
5/16"	CCK1.1/4-5/16	CKFN1.1/4-5/16C	CKFN1.1/4-5/16
3/8"	CCK1.1/4-3/8	CKFN1.1/4-3/8C	CKFN1.1/4-3/8
7/16"	CCK1.1/4-7/16	CKFN1.1/4-7/16C	CKFN1.1/4-7/16
1/2"	CCK1.1/4-1/2	CKFN1.1/4-1/2C	CKFN1.1/4-1/2
9/16"	CCK1.1/4-9/16	CKFN1.1/4-9/16C	CKFN1.1/4-9/16
5/8"	CCK1.1/4-5/8	CKFN1.1/4-5/8C	CKFN1.1/4-5/8
3/4"	CCK1.1/4-3/4	CKFN1.1/4-3/4C	CKFN1.1/4-3/4
7/8"	CCK1.1/4-7/8	CKFN1.1/4-7/8C	CKFN1.1/4-7/8
1"	CCK1.1/4-1	CKFN1.1/4-1C	CKFN1.1/4-1
6mm	CCK1.1/4-6	CKFN1.1/4-6C	CKFN1.1/4-6
8mm	CCK1.1/4-8	CKFN1.1/4-8C	CKFN1.1/4-8
10mm	CCK1.1/4-10	CKFN1.1/4-10C	CKFN1.1/4-10
12mm	CCK1.1/4-12	CKFN1.1/4-12C	CKFN1.1/4-12
14mm	CCK1.1/4-14	CKFN1.1/4-14C	CKFN1.1/4-14
16mm	CCK1.1/4-16	CKFN1.1/4-16C	CKFN1.1/4-16
20mm	CCK1.1/4-20	CKFN1.1/4-20C	CKFN1.1/4-20
25mm	CCK1.1/4-25	CKFN1.1/4-25C	CKFN1.1/4-25

**LYNDEX  
NIKKEN**  
STANDARD PRODUCT CATALOG



**LYNDEX  
NIKKEN**  
ADVANCED PRODUCT CATALOG



**NIKKEN**

## CNC ROTARY TABLE SERIES

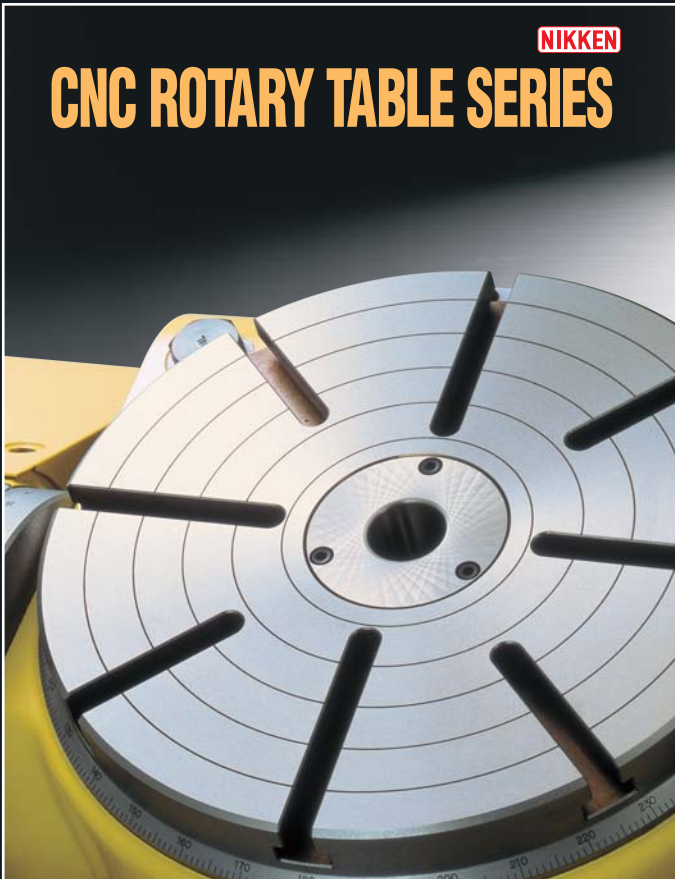

**LYNDEX  
NIKKEN**  
PRESETTER CATALOG





CUSTOM TOOLS CATALOG  
[www.lyndexnikken.com](http://www.lyndexnikken.com) • 800-543-6237

CAT2008-CUS