

THE TOOLS TO MEET YOUR MANUFACTURING NEEDS!



PRODUCT LINE CARD



ANGLE HEADS

EQUIPPED WITH GROUND GEARS AND COLLET SHAFTS!

- Vernier scales help to orient the cutting tool location (0 - 360°).
- With our collet seat recessed into the body of the angle head, rigidity is optimized while maintaining a compact design.
- Our angle heads are assembled with high precision, P4 quality spindle bearings that are stabilized for high speeds up to 15,000 RPM and high torques up to 110 ft-lbs.

SK COLLET CHUCKS

HOLDERS THAT ARE LEAN, TOUGH & EFFICIENT!

- Narrow body design accesses tight spots.
- Our steep 8° collet seats deeper in the body of the holder, providing 2x more gripping power than traditional 16° ER collets.
- Nikken guarantees a 3 micron runout tolerance for their “on size” fractional and metric size precision collets due to Nikken’s special heat treatment, grinding and custom slotting process.



MILLING CHUCKS

THE MOST RELIABLE AND POWERFUL TOOLHOLDER!

- Symmetrical design—pre-balanced body and nut allow the milling chuck to operate beyond 20,000 RPM.
- Outside bearing nut mechanically induces tight taper of the milling chuck to evenly collapse onto the cutting shank for high precision T.I.R.
- 6 angled coolant slots are standard, providing high pressure and high volume of coolant directed toward the periphery of the cutting tool.



COMPLETE
METALWORKING
SOLUTIONS

(800) 991-4225

www.ahbinc.com

ISO Certified

customerservice@ahbinc.com



THE TOOLS TO MEET YOUR MANUFACTURING NEEDS!

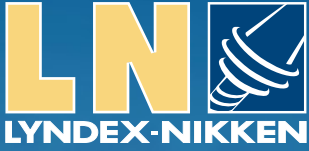

PRODUCT LINE CARD



SHRINK FIT SYSTEMS

THE INDUSTRY'S HIGHEST QUALITY SHRINK FIT LINE!

- Fastest shrinking time ranging from 2-7 seconds.
- Widest range available for a desktop unit 2-40mm (0.078" to 1.575").
- Can shrink most Cutting Tool materials from high speed steel to solid carbide.
- Special Shrink Fit machine and tool holder package available.

LIVE & STATIC TOOLS

TURN YOUR LATHE INTO A MILLING MACHINE!

- We offer both Live and Static Tools for a multitude of machines.
- Dual radial and thrust bearing design for added rigidity.
- Live and Static tools offered in coolant through, adjustable, and multi-output.

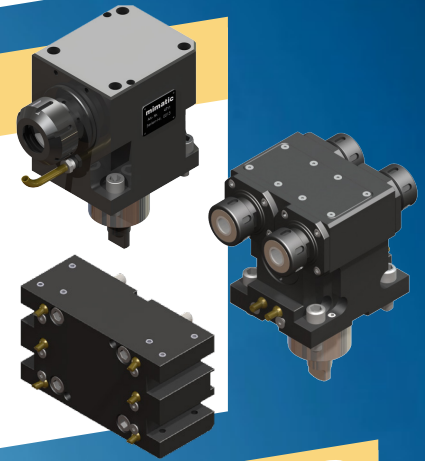

PRESETTERS

THERMAL STABILITY COUPLED WITH HIGH PRECISION!

- Precision ground granite is used for the base and column. This provides the utmost thermal stability for high repeatability and reproducibility during tool measuring and inspecting applications.
- Interchangeable spindles eliminate the need for adapters which can introduce additional errors.
- All units come with fifty of the most common post processors for today's CNC controls.

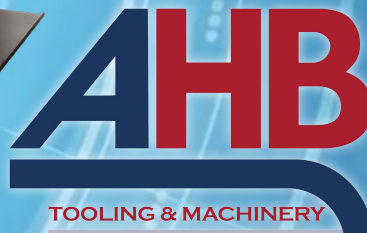

COMPLETE
METALWORKING
SOLUTIONS

(800) 991-4225

www.ahbinc.com

ISO Certified

customerservice@ahbinc.com

