

Live Tooling

OKUMA CAPTAIN SERIES LATHES

L370-M, L370-MW, L470-M

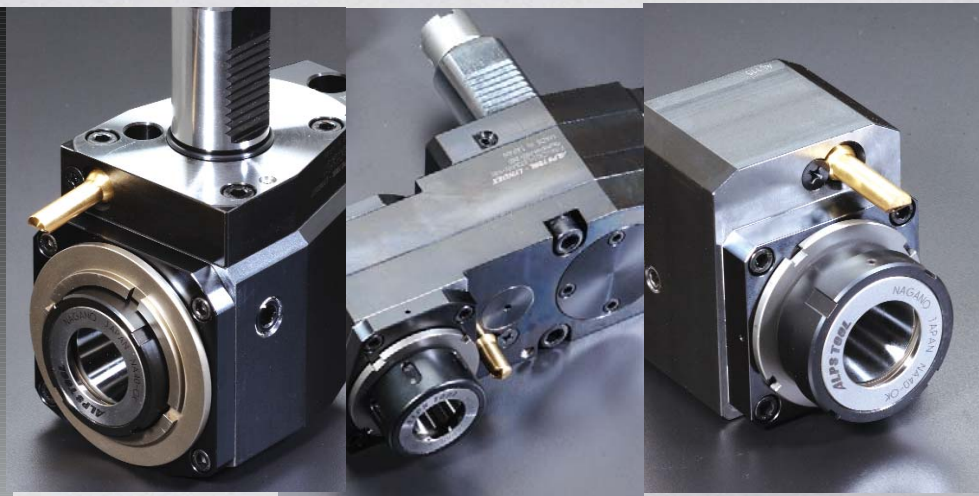

ALPS TOOL

Special Live Tool Inquiry Form

Fax: (847) 367-4815
Email: inquiries@lyndexnikken.com

Fill in the form below and fax it to (847) 367-4815, or visit www.lyndexnikken.com and complete the form online. Lyndex-Nikken engineers will help you to determine the best live tool for your application.

Company _____ Name _____
Address _____
Zip _____ City _____
Phone _____ E-mail _____

Please specify design configuration:

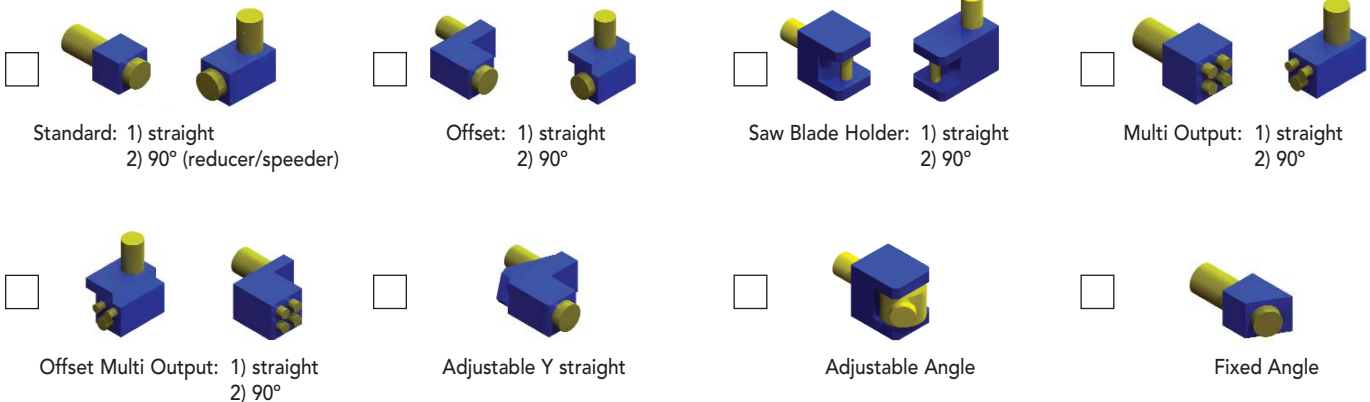

Please specify holding system and cutting tool specifications:

Holding System

Preferred type of holding system (ER, Shrink Fit, Shell Mill Arbor, etc.): _____

Application and Cutting Tool Specifications

Type of material: _____

Type and nature of application (milling, drilling, reaming, slitting, etc.): _____

Size of cutter (diameter): _____ Overall length of cutter: _____

Flute length: _____ Requested RPM: _____ Requested torque: _____

Coolant Requirements

External/Internal: _____ Requested pressure capabilities: _____

Number of nozzle ports: _____ Coolant pipe design or configuration specifications: _____



OKUMA LIVE TOOLING

<i>Special Live Tool Inquiry Form</i>	2
<i>Table of Contents</i>	3
<i>Introduction</i>	4
<i>Features and Technology</i>	5
<i>Live Tools for Okuma Captain Series L370-M</i>	6-8
<i>Live Tools for Okuma Captain Series L370-MW</i>	9-10
<i>Live Tools for Okuma Captain Series L470-M</i>	11-13
<i>ER Series Collets and Tap Collets</i>	14-17
<i>Wrench Usage, Warranty and Service</i>	18
<i>Torque Wrench</i>	19

Specials

Custom-made live tools can be engineered for your specific application. Please direct your request to our office (see special live tool inquiry form). Our engineering staff is ready to assist you with your specific tooling needs.



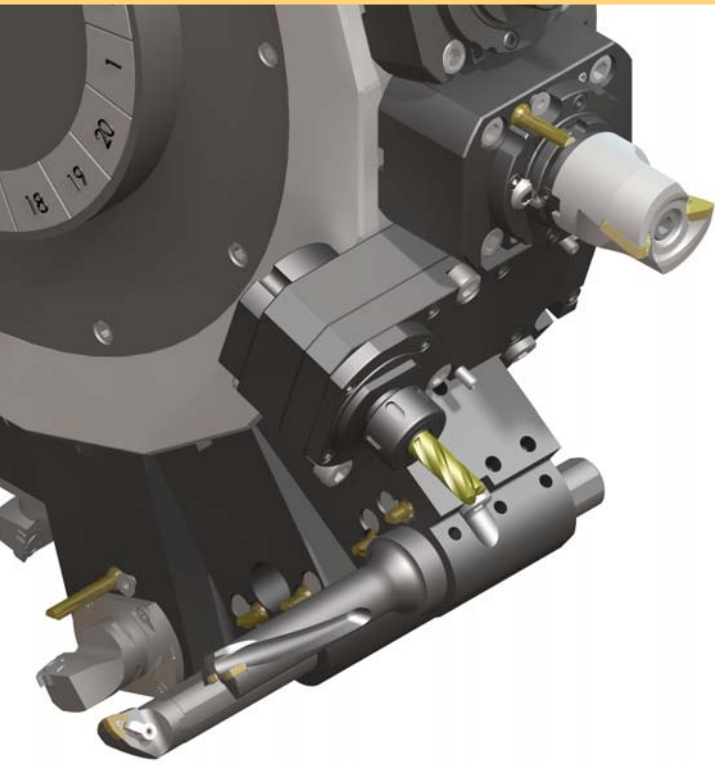

Turn Your Okuma Lathe into a Precision Profit Center

As a member of Partners in THINC, we work hand in hand with Okuma engineers at the Partners in THINC facility in Charlotte, NC. Not only are our live tools custom-engineered specifically for Okuma lathes, but also they are optimal application solutions based on collaborative engineering.

Alps/Lyndex-Nikken live tooling offers the latest technology you can expect for turning operations. Designed and manufactured directly with Okuma engineers in Japan, our live tools have features and benefits unmatched by the competition. Gears, bearings, seals, every part is built to provide the highest accuracy, rigidity and stability.

With more than 30 years of tooling engineering and manufacturing experience, Lyndex-Nikken live tooling will maximize the capabilities of your machine, and keep you far ahead of the global competition. We understand that exceptional quality is key to your business. Let the manufacturers who share your philosophy in producing live tools join you in doing what you do best- machining the highest quality parts.

Enhanced with Alps/Lyndex-Nikken live tooling, your Okuma machine will allow you to reduce cycle times, eliminate extra operations and achieve maximum efficiency.

Parts inventory, maintenance and repair, and rebuild services are available through Lyndex-Nikken.



Lyndex-Nikken is an official Okuma Live Tool supplier and a member of Partners in THINC.



Lyndex-Nikken live tools are manufactured by Alps Tool Co. Ltd.

FEATURES AND TECHNOLOGY

As an authorized OEM supplier to Okuma, Lyndex-Nikken live tools are designed and manufactured in conjunction with Okuma engineers at the factory in Japan.

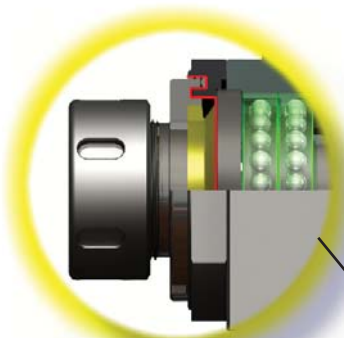

Protective Seals

- **Labyrinth Seals** - provide a high-pressure multi-barrier construction that prevents contaminants and coolant from entering the main chamber.



Eccentric Bearing Nut

- **Ground Eccentric Nut** - allows for fine accuracy and strong tool shank gripping capacity by preventing collet twisting or rocking.
- **Runout** - guarantee of under 5-micron repeatability at collet nose.

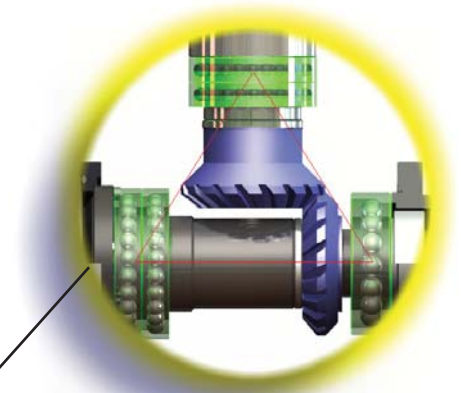
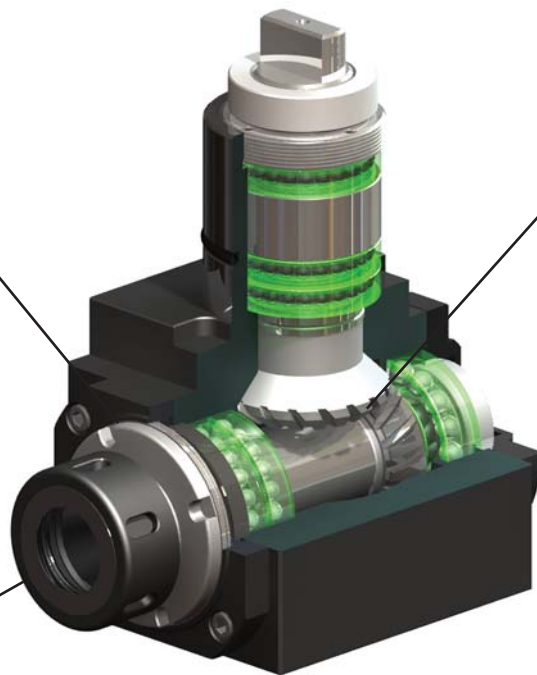

Gears for Stability

- **Gear Pairing** - hand-matched for each pair to minimize backlash.
- **Gear Design** - custom ground spiral bevel gear tooth design maximizes drive torque output and reduces tooth root stress allowing for more tool longevity.
- **Gear Equilibrium** - placement of bearings balance torque stress evenly through input/output shafts.

Tool Design and Engineering

- **Tool Body** - manufactured from the highest tensile and compression Nickel Chrome Molybdenum alloys.
- **Drive Shafts** - all features are ground on both the input and output Chrome Molybdenum drive shafts to assure proper torque transmission and precision concentricity.
- **Bearing Quality** - only the highest precision ABEC 7 angular contact bearings are used for smooth and high speed rotation.
- **Quality Control** - all live tools go through a vigorous 60-point final inspection to satisfy the highest expectations of live tool performance.

OD Drill/Milling Unit

Part #: **LYNDEX NIKKEN** OK101-14000 **OKUMA** T129-530-000-58

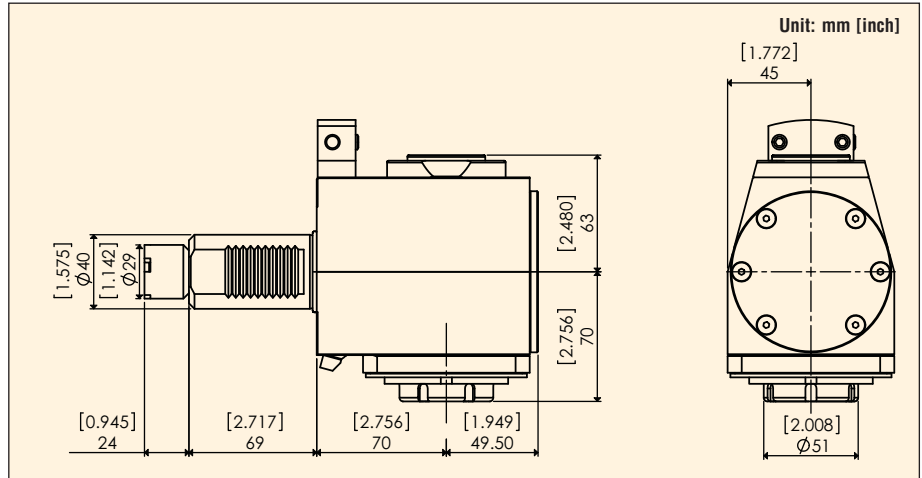
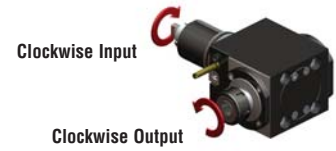

External or Internal Coolant	Radial/ Axial	Max. RPM	Gear Ratio	Max. Torque Output	Max. Pressure	Collet Size	Replacement Nut	Clutch Kit	Setting Fixture	Coolant Nozzle	Spanner Wrench for Nut
External	Radial	4500	1:1	17.3 ft-lbs (24N-m)	1000 PSI	ER32 (1/8" to 25/32")	OK105-00100	OK116-20200	OK116-00800	OK116-70610	FK-8

Please refer to pages 14 - 17 for ER Series Collets and ER Tap Collets details.

OD Drill/Milling Unit

Part #: **LYNDEX NIKKEN** OK101-67000

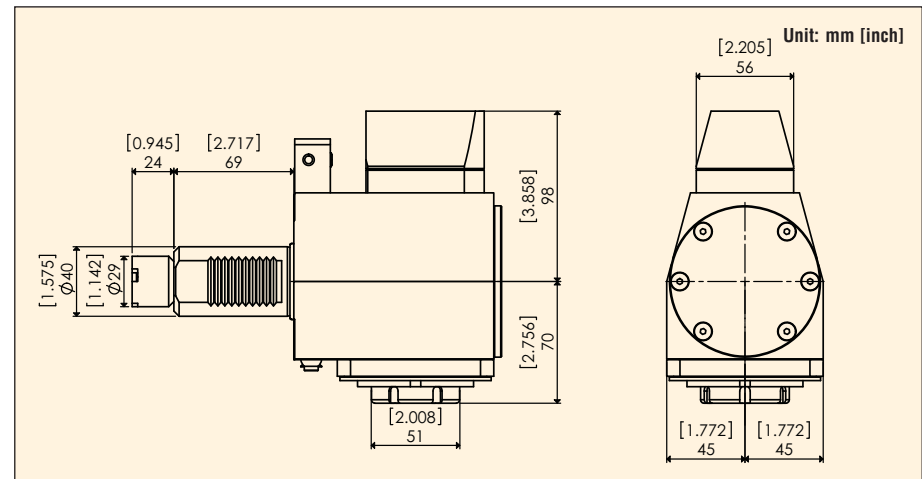

External or Internal Coolant	Radial/ Axial	Max. RPM	Gear Ratio	Max. Torque Output	Max. Pressure	Collet Size	Replacement Nut	Clutch Kit	Setting Fixture	Coolant Nozzle	Spanner Wrench for Nut
Internal	Radial	4500	1:1	17.3 ft-lbs (24N-m)	1000 PSI	ER32 (1/8" to 25/32")	OK105-00100	OK116-20200	OK116-00800	PM2B-1	FK-8

This tool requires a minimum 20 micron filter and cannot be run dry.
Please refer to pages 14 - 17 for ER Series Collets and ER Tap Collets details.

Face Drill/Milling Unit

Part #: **LYNDEX NIKKEN** OK101-13000 **OKUMA** T129-530-000-57

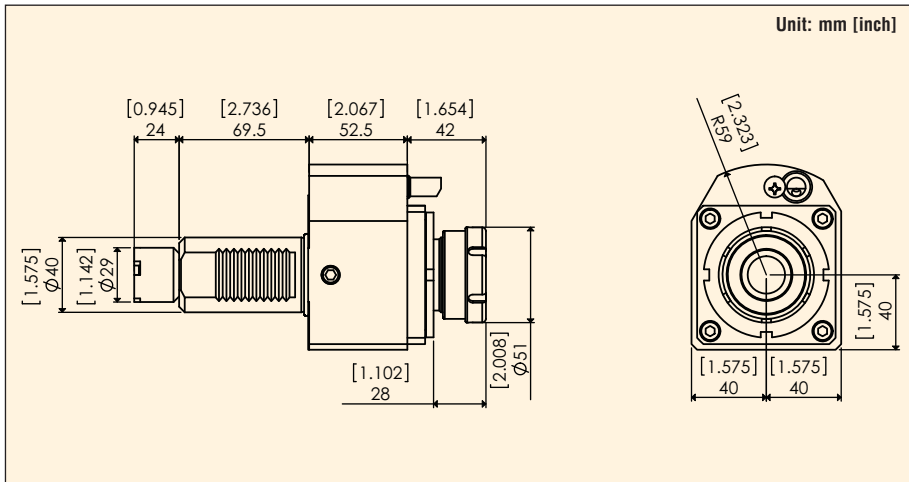
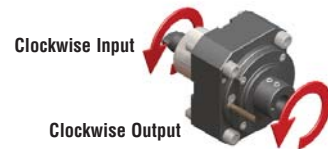

External or Internal Coolant	Radial/Axial	Max. RPM	Gear Ratio	Max. Torque Output	Max. Pressure	Collet Size	Replacement Nut	Clutch Kit	Setting Fixture	Coolant Nozzle	Spanner Wrench for Nut
External	Axial	4500	1:1	17.3 ft-lbs (24N-m)	1000 PSI	ER32 (1/8" to 25/32")	OK105-00100	OK116-20200	OK116-00700	OK116-70060	FK-8

Please refer to pages 14 - 17 for ER Series Collets and ER Tap Collets details.

Face Drill/Milling Unit

Part #: **LYNDEX NIKKEN** OK101-72000

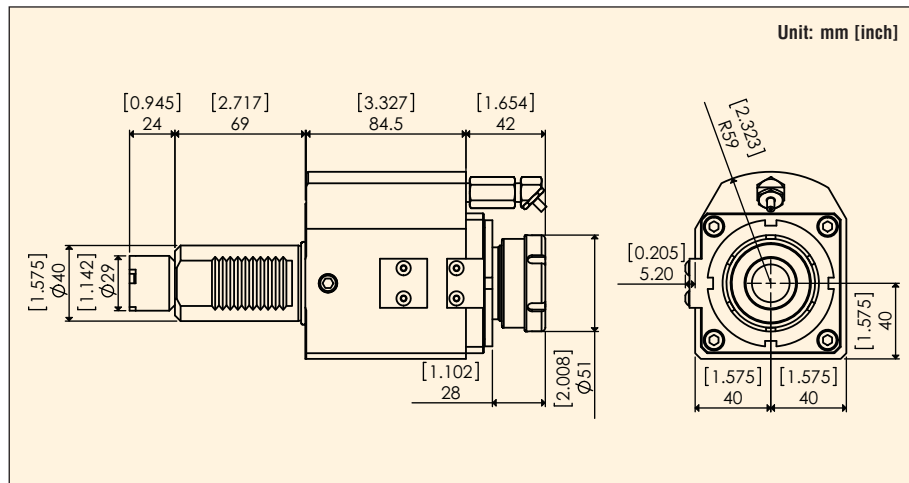
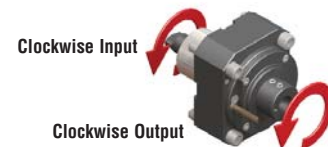

External or Internal Coolant	Radial/Axial	Max. RPM	Gear Ratio	Max. Torque Output	Max. Pressure	Collet Size	Replacement Nut	Clutch Kit	Setting Fixture	Coolant Nozzle	Spanner Wrench for Nut
Internal	Axial	4500	1:1	17.3 ft-lbs (24N-m)	1000 PSI	ER32 (1/8" to 25/32")	OK105-00100	OK116-20200	OK116-00700	PM2B-1 & EXTGSF-1-24	FK-8

This tool requires a minimum 20 micron filter and cannot be run dry.
Please refer to pages 14 - 17 for ER Series Collets and ER Tap Collets details.

Adjustable Holder

Part #: **LYNDEX** **NIKKEN** OK101-73000

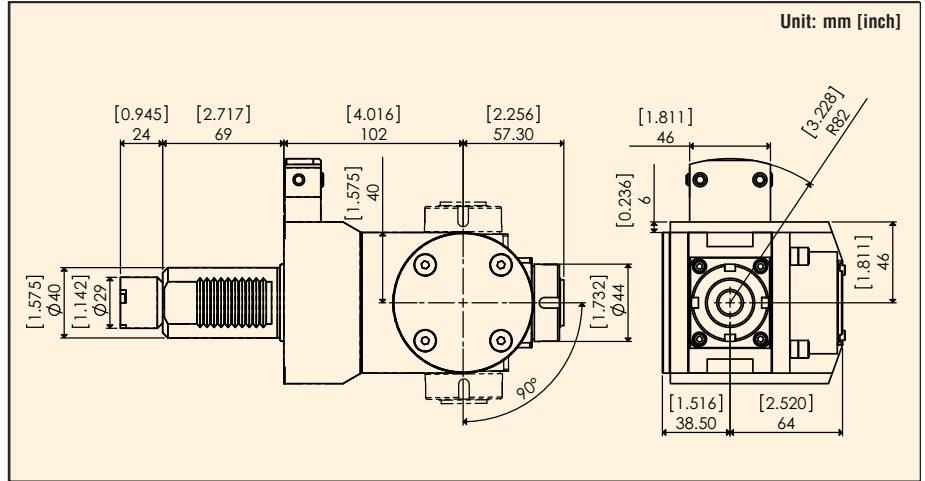
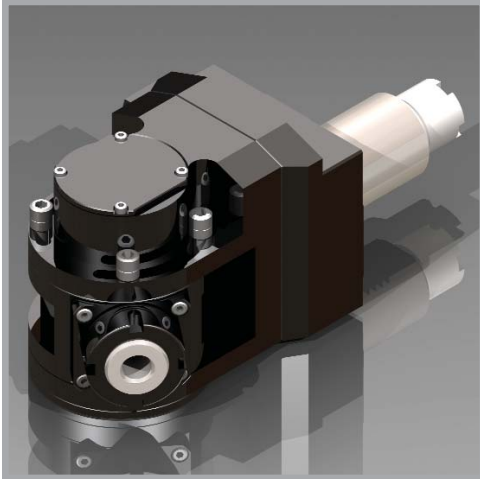
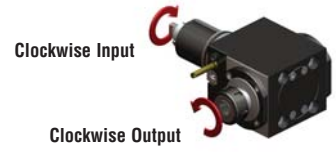

External or Internal Coolant	Radial/Axial	Max. RPM	Gear Ratio	Max. Torque Output	Max. Pressure	Collet Size	Replacement Nut	Clutch Kit	Wrench for Spindle	Coolant Nozzle	Spanner Wrench for Nut
External	Adjustable	4000	1:1	7.37 ft-lbs (10N-m)	1000 PSI	ER20 (1/16" to 1/2")	Hi-Q/ERAX20	OK116-20200	FK-7	PA-6/PB-6/PH-6/PAP CU6x4x130	E20AX

Please refer to pages 14 - 17 for ER Series Collets and ER Tap Collets details.

Face Drill/Milling Unit - Main

Part #: **LYNDEX NIKKEN** OK109-13001 **LOKUMA** T129-530-000-79

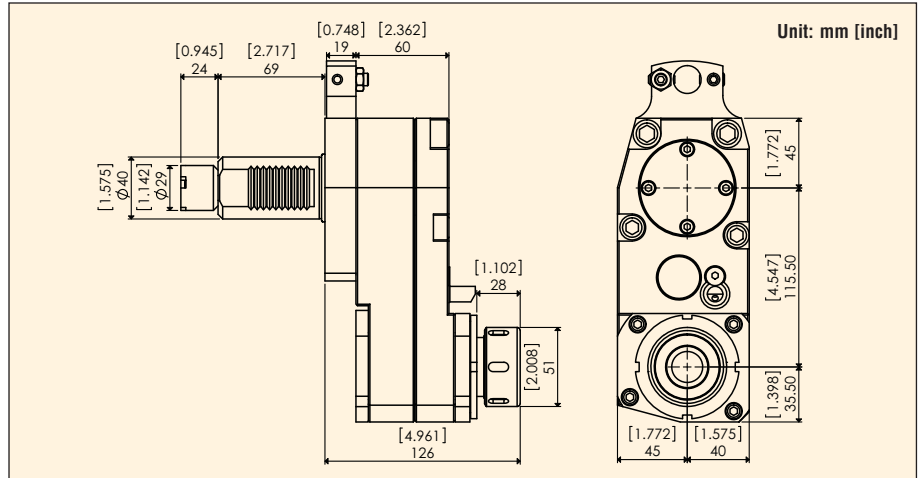
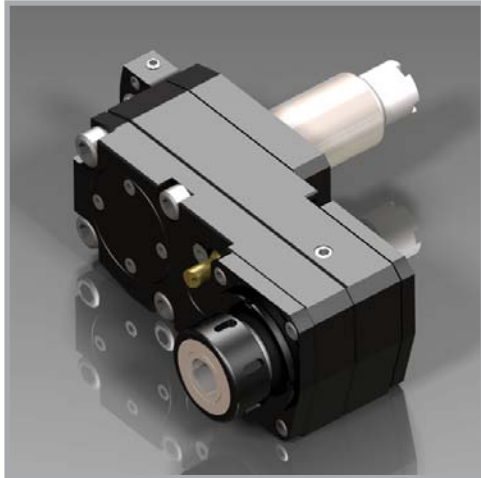
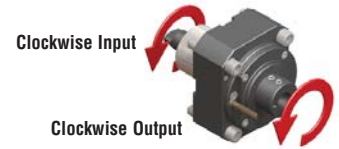

External or Internal Coolant	Radial/Axial	Max. RPM	Gear Ratio	Max. Torque Output	Max. Pressure	Collet Size	Replacement Nut	Clutch Kit	Setting Fixture	Coolant Nozzle	Spanner Wrench for Nut
External	Offset (M)	4500	1:1	17.3 ft-lbs (24N-m)	1000 PSI	ER32 (1/8" to 25/32")	NA 32	OK116-20200	OK116-00500	OK116-70060	FK-8

Please refer to pages 14 - 17 for ER Series Collets and ER Tap Collets details.

Face Drill/Milling Unit - Sub

Part #: **LYNDEX NIKKEN** OK109-14001 **LOKUMA** T129-530-000-80

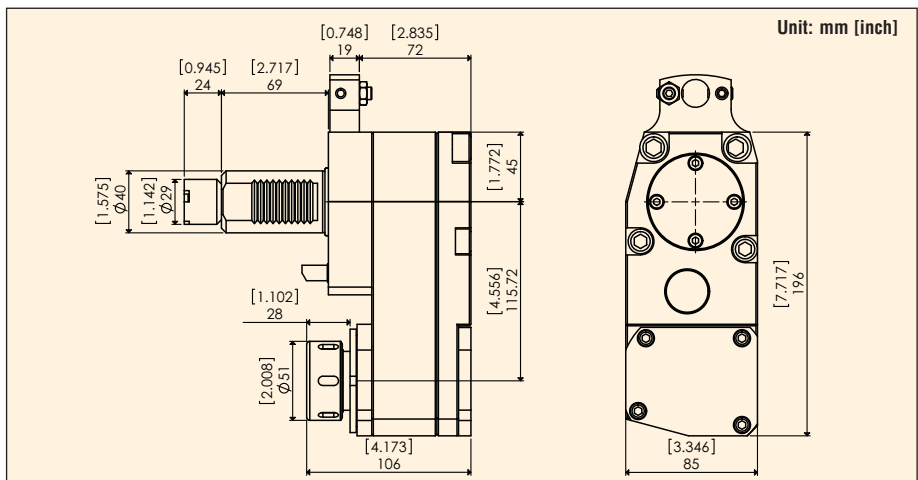
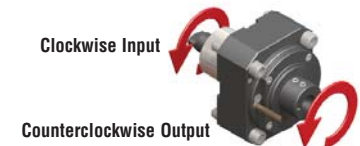

External or Internal Coolant	Radial/Axial	Max. RPM	Gear Ratio	Max. Torque Output	Max. Pressure	Collet Size	Replacement Nut	Clutch Kit	Setting Fixture	Coolant Nozzle	Spanner Wrench for Nut
External	Axial	4500	1:1	17.3 ft-lbs (24N-m)	1000 PSI	ER32 (1/8" to 25/32")	NA 32	OK116-20200	OK116-01900	OK116-70060	FK-8

Please refer to pages 14 - 17 for ER Series Collets and ER Tap Collets details.

Face Drill/Milling Unit - Double

Part #: **LYNDEX NIKKEN** OK109-15001 **OKUMA** T129-530-000-78

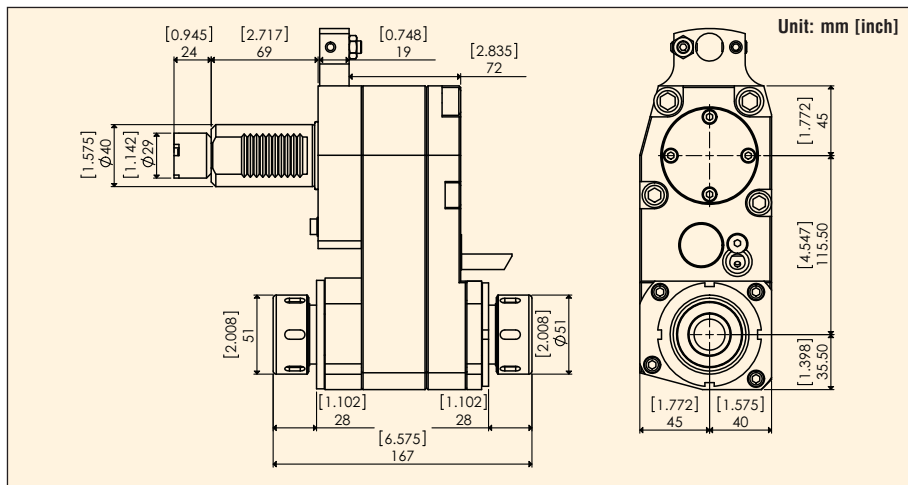
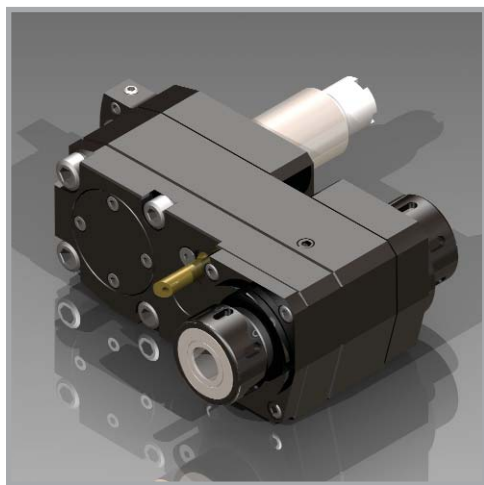

External or Internal Coolant	Radial/Axial	Max. RPM	Gear Ratio	Max. Torque Output	Max. Pressure	Collet Size	Replacement Nut	Clutch Kit	Setting Fixture	Coolant Nozzle	Spanner Wrench for Nut
External	Offset (D)	4500	1:1	17.3 ft-lbs (24N-m)	1000 PSI	ER32 (1/8" to 25/32")	NA 32	OK116-20200	OK116-00500	main:OK116-70290 sub:OK116-70250 plug:OK116-70090	FK-8

On the main spindle, the clutch shaft and the collet shaft rotate in the same direction; on the sub spindle, they rotate in opposite directions. Please refer to pages 14 - 17 for ER Series Collets and ER Tap Collets details.

OD Drill/Milling Unit

Part #: **LYNDEX NIKKEN** OK101-14000 **OKUMA** T129-530-000-58

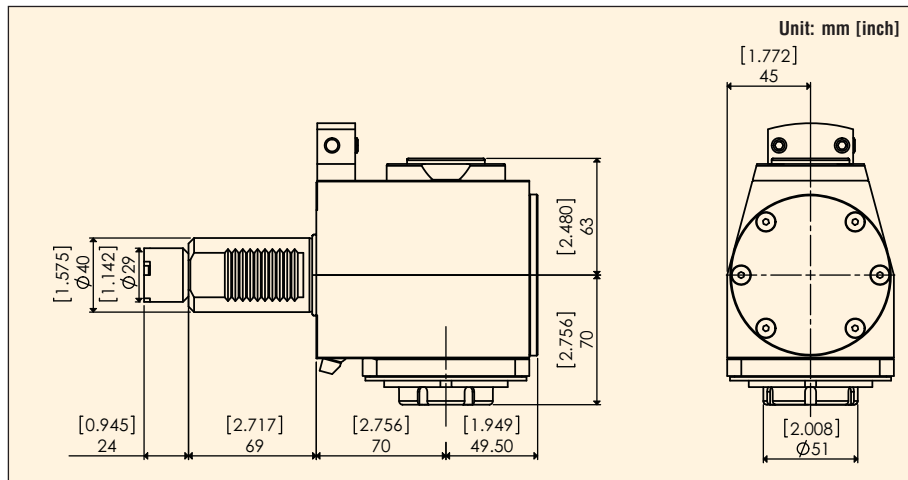
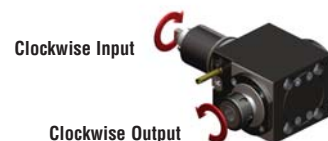

External or Internal Coolant	Radial/Axial	Max. RPM	Gear Ratio	Max. Torque Output	Max. Pressure	Collet Size	Replacement Nut	Clutch Kit	Setting Fixture	Coolant Nozzle	Spanner Wrench for Nut
External	Radial	4500	1:1	17.3 ft-lbs (24N-m)	1000 PSI	ER32 (1/8" to 25/32")	OK105-00100	OK116-20200	OK116-00800	OK116-70610	FK-8

Please refer to pages 14 - 17 for ER Series Collets and ER Tap Collets details.

OD Drill/Milling Unit

Part #: **LYNDEX NIKKEN** OK102-18000

Clockwise Input

Clockwise Output

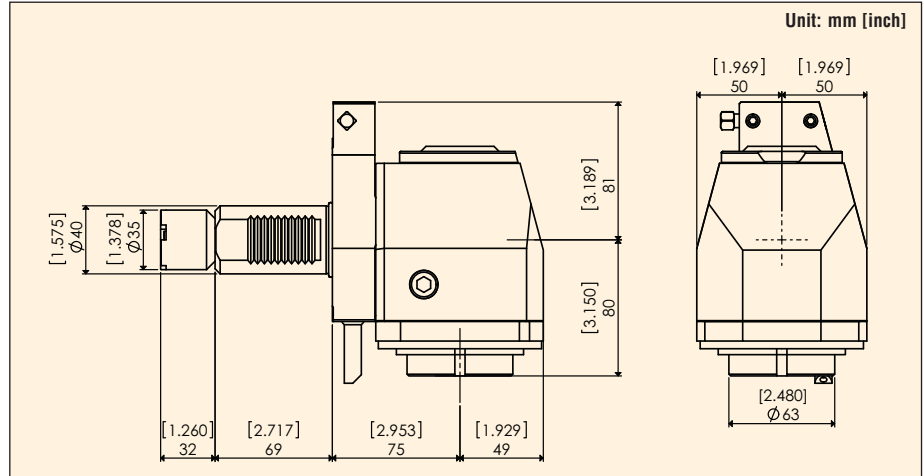

External or Internal Coolant	Radial/Axial	Max. RPM	Gear Ratio	Max. Torque Output	Max. Pressure	Collet Size	Replacement Nut	Clutch Kit	Setting Fixture	Coolant Nozzle	Spanner Wrench for Nut
External	Radial	3000	1:1	26.0 ft-lbs (35.3N-m)	1000 PSI	ER40 (5/32" to 1")	OK116-70980	OK116-20300	OK116-01000	OK116-70930	FK-9

Please refer to pages 14 - 17 for ER Series Collets and ER Tap Collets details.

OD Drill/Milling Unit

Part #: **LYNDEX NIKKEN** OK102-23000



Clockwise Input

Clockwise Output

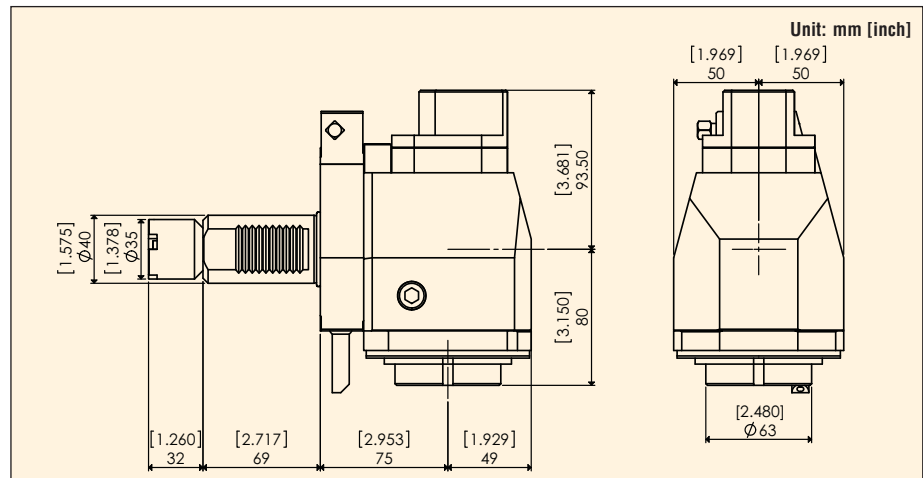

External or Internal Coolant	Radial/Axial	Max. RPM	Gear Ratio	Max. Torque Output	Max. Pressure	Collet Size	Replacement Nut	Clutch Kit	Setting Fixture	Coolant Nozzle	Spanner Wrench for Nut
Internal	Radial	3000	1:1	26.0 ft-lbs (35.3N-m)	1000 PSI	ER40 (5/32" to 1")	OK116-70980	OK116-20300	OK116-01000	OK116-70930	FK-9

This tool requires a minimum 20 micron filter and cannot be run dry.
Please refer to pages 14 - 17 for ER Series Collets and ER Tap Collets details.

Face Drill/Milling Unit

Part #: **LYNDEX NIKKEN** OK102-17000

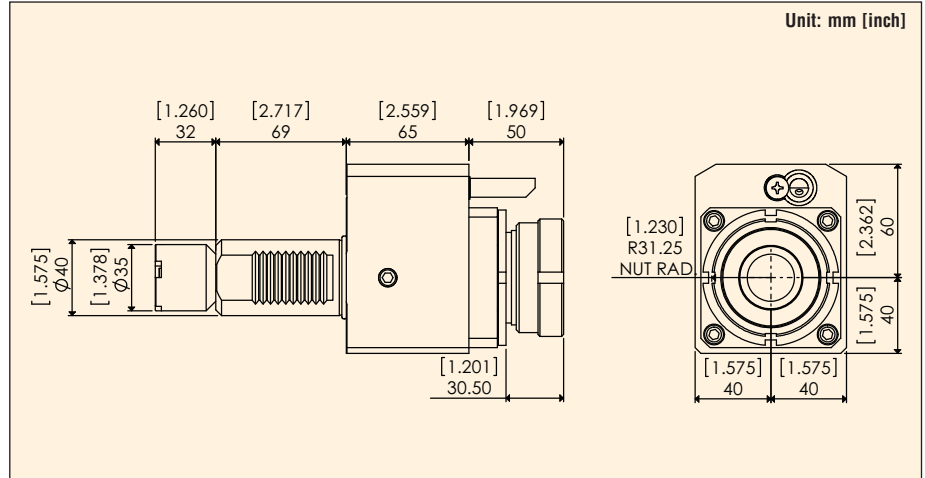
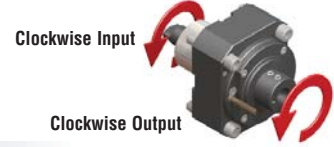

External or Internal Coolant	Radial/Axial	Max. RPM	Gear Ratio	Max. Torque Output	Max. Pressure	Collet Size	Replacement Nut	Clutch Kit	Setting Fixture	Coolant Nozzle	Spanner Wrench for Nut
External	Axial	3000	1:1	26.0 ft-lbs (35.3N-m)	1000 PSI	ER40 (5/32" to 1")	OK116-70980	OK116-20300	OK116-00900	OK116-70930	FK-9

Please refer to pages 14 - 17 for ER Series Collets and ER Tap Collets details.

Face Drill/Milling Unit

Part #: **LYNDEX NIKKEN** OK102-22000

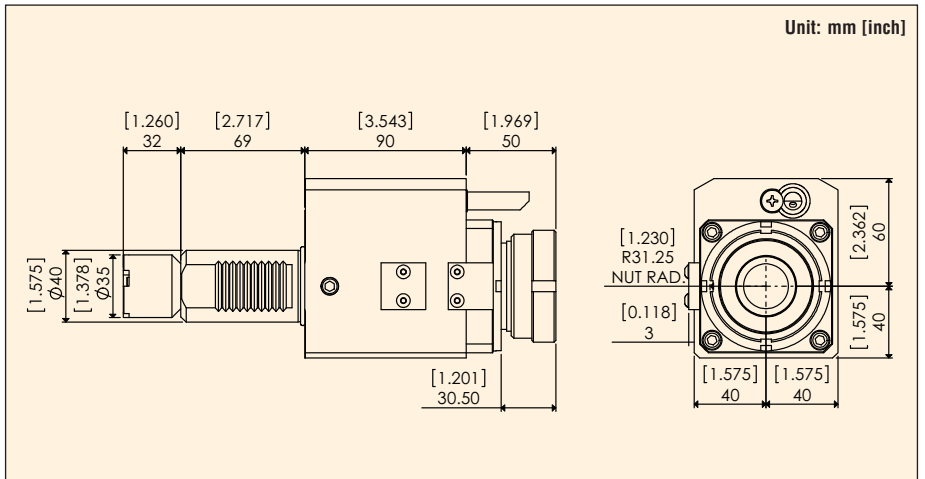
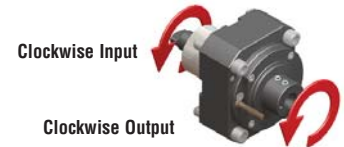

External or Internal Coolant	Radial/Axial	Max. RPM	Gear Ratio	Max. Torque Output	Max. Pressure	Collet Size	Replacement Nut	Clutch Kit	Setting Fixture	Coolant Nozzle	Spanner Wrench for Nut
Internal	Axial	3000	1:1	26.0 ft-lbs (35.3N-m)	1000 PSI	ER40 (5/32" to 1")	OK116-70980	OK116-20300	OK116-00900	OK116-70930	FK-9

This tool requires a minimum 20 micron filter and cannot be run dry.
Please refer to pages 14 - 17 for ER Series Collets and ER Tap Collets details.

Adjustable Holder

Part #: **LYNDEX** **NIKKEN** OK102-24000

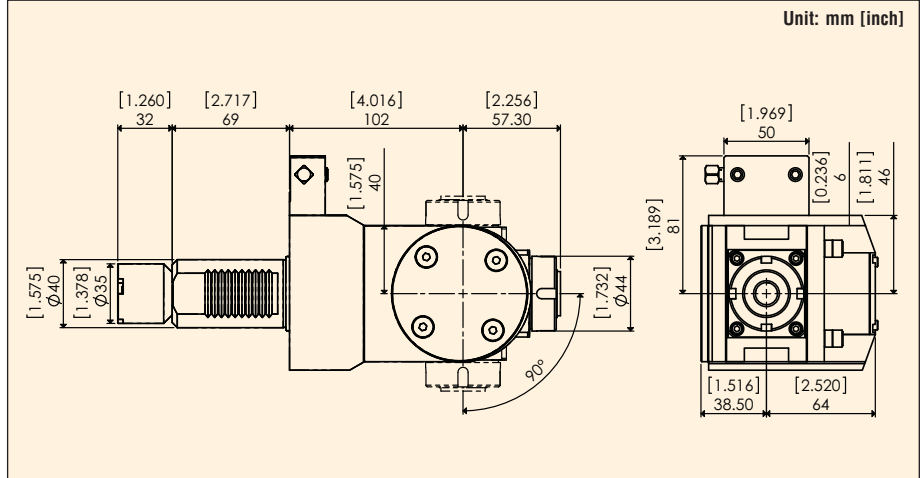

External or Internal Coolant	Radial/Axial	Max. RPM	Gear Ratio	Max. Torque Output	Max. Pressure	Collet Size	Replacement Nut	Clutch Kit	Wrench for Spindle	Coolant Nozzle	Spanner Wrench for Nut
External	Adjustable	4000	1:1	7.37 ft-lbs (10N-m)	1000 PSI	ER20 (1/16" to 1/2")	Hi-Q/ERAX20	OK116-20300	FK-7	PA-6/PB-6/PH-6/PAP CU6x4x130	E20AX

Please refer to pages 14 - 17 for ER Series Collets and ER Tap Collets details.

ER Series Collets

STANDARD (INCH)

SIZE	ER16	ER20	ER25	ER32	ER40
1/32"	E16-002	-	-	-	-
1/16"	E16-004	E20-004	E25-004	-	-
3/32"	E16-006	E20-006	E25-006	-	-
1/8"	E16-008	E20-008	E25-008	E32-008	-
5/32"	E16-010	E20-010	E25-010	E32-010	E40-010
3/16"	E16-012	E20-012	E25-012	E32-012	E40-012
7/32"	E16-014	E20-014	E25-014	E32-014	E40-014
1/4"	E20-016	E20-016	E25-016	E32-016	E40-016
9/32"	E20-018	E20-018	E25-018	E32-018	E40-018
5/16"	E20-020	E20-020	E25-020	E32-020	E40-020
11/32"	E20-022	E20-022	E25-022	E32-022	E40-022
3/8"	E20-024	E20-024	E25-024	E32-024	E40-024
13/32"	E20-026	E20-026	E25-026	E32-026	E40-026
7/16"	-	E20-028	E25-028	E32-028	E40-028
15/32"	-	E20-030	E25-030	E32-030	E40-030
1/2"	-	E20-032	E25-032	E32-032	E40-032
17/32"	-	-	E25-034	E32-034	E40-034
9/16"	-	-	E25-036	E32-036	E40-036
19/32"	-	-	E25-038	E32-038	E40-038
5/8"	-	-	E25-040	E32-040	E40-040
21/32"	-	-	-	E32-042	E40-042
11/16"	-	-	-	E32-044	E40-044
23/32"	-	-	-	E32-046	E40-046
3/4"	-	-	-	E32-048	E40-048
25/32"	-	-	-	E32-050	E40-050
13/16"	-	-	-	-	E40-052
27/32"	-	-	-	-	E40-044
7/8"	-	-	-	-	E40-056
29/32"	-	-	-	-	E40-058
15/16"	-	-	-	-	E40-060
31/32"	-	-	-	-	E40-062
1"	-	-	-	-	E40-064

STANDARD (METRIC)

SIZE	ER16	ER20	ER25	ER32	ER40
1.0mm	E16-039	-	-	-	-
1.5mm	E16-059	-	-	-	-
2.0mm	E16-078	E20-078	E25-078	-	-
3.0mm	E16-118	E20-118	E25-118	E32-118	-
3.5mm	E16-137	E20-137	E25-137	E32-137	-
4.0mm	E16-157	E20-157	E25-157	E32-157	E40-157
5.0mm	E16-196	E20-196	E25-196	E32-196	E40-196
6.0mm	E16-236	E20-236	E25-236	E32-236	E40-236
7.0mm	E16-275	E20-275	E25-275	E32-275	E40-275
8.0mm	E16-314	E20-314	E25-314	E32-314	E40-314
9.0mm	E16-354	E20-354	E25-354	E32-354	E40-354
10.0mm	E16-393	E20-393	E25-393	E32-393	E40-393
11.0mm	-	E20-433	E25-433	E32-433	E40-433
11.5mm	-	E20-452	E25-452	E32-452	E40-452
12.0mm	-	E20-472	E25-472	E32-472	E40-472
13.0mm	-	E20-511	E25-511	E32-511	E40-511
14.0mm	-	-	E25-551	E32-551	E40-551
15.0mm	-	-	E25-590	E32-590	E40-590
16.0mm	-	-	E25-629	E32-629	E40-629
17.0mm	-	-	-	E32-669	E40-669
18.0mm	-	-	-	E32-708	E40-708
19.0mm	-	-	-	E32-748	E40-748
19.5mm	-	-	-	E32-767	E40-767
20.0mm	-	-	-	E32-787	E40-787
21.0mm	-	-	-	-	E40-826
22.0mm	-	-	-	-	E40-866
23.0mm	-	-	-	-	E40-905
24.0mm	-	-	-	-	E40-944
25.0mm	-	-	-	-	E40-984
26.0mm	-	-	-	-	E40-1023

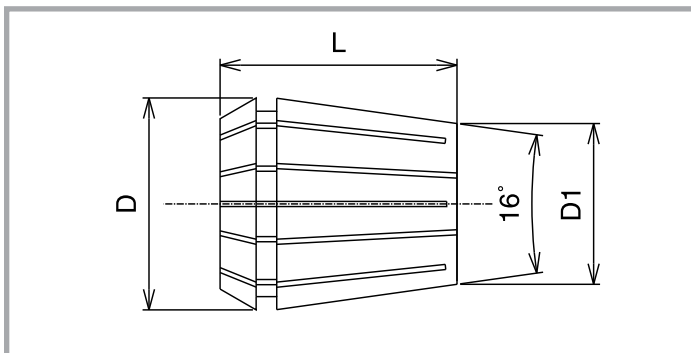

ER Standard type collet

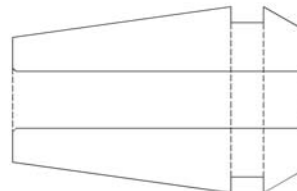

ER Counter-Bored type collet

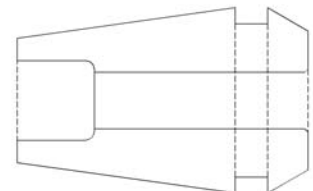

Style	D	D1	L	Collet Range	Coolant Collet Size Range	Nut Tightening Torque	
						standard collet	counter-bored collet
ER16	17.2mm	11.3mm	27.0mm	0.5 - 10.0mm	4.0 - 10.0mm (3/16" - 17/64")	30 - 37 ft-lbs	18 - 22 ft-lbs
ER20	21.2mm	14.5mm	31.0mm	1.0 - 13.0mm	5.0 - 13.0mm (5/32" - 1/2")	60 - 74 ft-lbs	42 - 52 ft-lbs
ER25	26.2mm	18.5mm	35.0mm	1.0 - 16.0mm	6.0 - 16.0mm (7/32" - 5/8")	77 - 96 ft-lbs	54 - 67 ft-lbs
ER32	33.2mm	24.4mm	40.0mm	2.0 - 20.0mm	10.0 - 20.0mm (1/4" - 25/32")	100 - 125 ft-lbs	77 - 96 ft-lbs
ER40	41.2mm	31.2mm	46.0mm	3.0mm - 26.0mm	10.0 - 26.0mm	125 - 157 ft-lbs	130 - 162 ft-lbs

ER Series Coolant Collets

COOLANT (INCH)

SIZE	ER16	ER20	ER25	ER32
3/32"	E16-006(C)	-	-	-
7/64"	E16-007(C)	-	-	-
1/8"	E16-008(C)	-	-	-
9/64"	E16-009(C)	-	-	-
5/32"	E16-010(C)	E20-010(C)	-	-
11/64"	E16-011(C)	E20-011(C)	-	-
3/16"	E16-012(C)	E20-012(C)	-	-
13/64"	E16-013(C)	E20-013(C)	-	-
7/32"	E16-014(C)	E20-014(C)	E25-014(C)	-
15/64"	E16-015(C)	E20-015(C)	E25-015(C)	-
1/4"	E16-016(C)	E20-016(C)	E25-016(C)	E32-016(C)
17/64"	E16-017(C)	E20-017(C)	E25-017(C)	E32-017(C)
9/32"	E16-018(C)	E20-018(C)	E25-018(C)	E32-018(C)
19/64"	E16-019(C)	E20-019(C)	E25-019(C)	E32-019(C)
5/16"	E16-020(C)	E20-020(C)	E25-020(C)	E32-020(C)
21/64"	E16-021(C)	E20-021(C)	E25-021(C)	E32-021(C)
11/32"	E16-022(C)	E20-022(C)	E25-022(C)	E32-022(C)
23/64"	E16-023(C)	E20-023(C)	E25-023(C)	E32-023(C)
3/8"	E16-024(C)	E20-024(C)	E25-024(C)	E32-024(C)
25/64"	E16-025(C)	E20-025(C)	E25-025(C)	E32-025(C)
13/32"	E16-026(C)	E20-026(C)	E25-026(C)	E32-026(C)
27/64"	-	E20-027(C)	E25-027(C)	E32-027(C)
7/16"	-	E20-028(C)	E25-028(C)	E32-028(C)
29/64"	-	E20-029(C)	E25-029(C)	E32-029(C)
15/32"	-	E20-030(C)	E25-030(C)	E32-030(C)
31/64"	-	E20-031(C)	E25-031(C)	E32-031(C)
1/2"	-	E20-032(C)	E25-032(C)	E32-032(C)
33/64"	-	-	E25-033(C)	E32-033(C)
17/32"	-	-	E25-034(C)	E32-034(C)
35/64"	-	-	E25-035(C)	E32-035(C)
9/16"	-	-	E25-036(C)	E32-036(C)
37/64"	-	-	E25-037(C)	E32-037(C)
19/32"	-	-	E25-038(C)	E32-038(C)
39/64"	-	-	E25-039(C)	E32-039(C)
5/8"	-	-	E25-040(C)	E32-040(C)
41/64"	-	-	-	E32-041(C)
21/32"	-	-	-	E32-042(C)
43/64"	-	-	-	E32-043(C)
11/16"	-	-	-	E32-044(C)
45/64"	-	-	-	E32-045(C)
23/32"	-	-	-	E32-046(C)
47/64"	-	-	-	E32-047(C)
3/4"	-	-	-	E32-048(C)
49/64"	-	-	-	E32-049(C)
25/32"	-	-	-	E32-050(C)

COOLANT (METRIC)

SIZE	ER16	ER20	ER25	ER32	ER40
4.0mm	E16-157(C)	-	-	-	-
4.5mm	E16-177(C)	-	-	-	-
5.0mm	E16-196(C)	E20-196(C)	-	-	-
5.5mm	E16-216(C)	E20-216(C)	-	-	-
6.0mm	E16-236(C)	E20-236(C)	E25-236(C)	-	-
6.5mm	E16-255(C)	E20-255(C)	E25-255(C)	-	-
7.0mm	E16-275(C)	E20-275(C)	E25-275(C)	-	-
7.5mm	E16-295(C)	E20-295(C)	E25-295(C)	-	-
8.0mm	E16-314(C)	E20-314(C)	E25-314(C)	-	-
8.5mm	E16-334(C)	E20-334(C)	E25-334(C)	-	-
9.0mm	E16-354(C)	E20-354(C)	E25-354(C)	-	-
9.5mm	E16-374(C)	E20-374(C)	E25-374(C)	-	-
10.0mm	E16-393(C)	E20-393(C)	E25-393(C)	E32-393(C)	E40-393(C)
10.5mm	-	E20-413(C)	E25-413(C)	E32-413(C)	E40-413(C)
11.0mm	-	E20-433(C)	E25-433(C)	E32-433(C)	E40-433(C)
11.5mm	-	E20-452(C)	E25-452(C)	E32-452(C)	E40-452(C)
12.0mm	-	E20-472(C)	E25-472(C)	E32-472(C)	E40-472(C)
12.5mm	-	E20-492(C)	E25-492(C)	E32-492(C)	E40-492(C)
13.0mm	-	E20-511(C)	E25-511(C)	E32-511(C)	E40-511(C)
13.5mm	-	-	E25-531(C)	E32-531(C)	E40-531(C)
14.0mm	-	-	E25-551(C)	E32-551(C)	E40-551(C)
14.5mm	-	-	E25-570(C)	E32-570(C)	E40-570(C)
15.0mm	-	-	E25-590(C)	E32-590(C)	E40-590(C)
15.5mm	-	-	E25-610(C)	E32-610(C)	E40-610(C)
16.0mm	-	-	E25-629(C)	E32-629(C)	E40-629(C)
16.5mm	-	-	-	E32-649(C)	E40-649(C)
17.0mm	-	-	-	E32-669(C)	E40-669(C)
17.5mm	-	-	-	E32-688(C)	E40-688(C)
18.0mm	-	-	-	E32-708(C)	E40-708(C)
18.5mm	-	-	-	E32-728(C)	E40-728(C)
19.0mm	-	-	-	E32-748(C)	E40-748(C)
19.5mm	-	-	-	E32-767(C)	E40-767(C)
20.0mm	-	-	-	E32-787(C)	E40-787(C)
20.5mm	-	-	-	-	E40-807(C)
21.0mm	-	-	-	-	E40-826(C)
21.5mm	-	-	-	-	E40-846(C)
22.0mm	-	-	-	-	E40-866(C)
22.5mm	-	-	-	-	E40-885(C)
23.0mm	-	-	-	-	E40-905(C)
23.5mm	-	-	-	-	E40-925(C)
24.0mm	-	-	-	-	E40-944(C)
24.5mm	-	-	-	-	E40-964(C)
25.0mm	-	-	-	-	E40-984(C)
25.5mm	-	-	-	-	E40-1003(C)
26.0mm	-	-	-	-	E40-1023(C)



ER Series Tap Collets

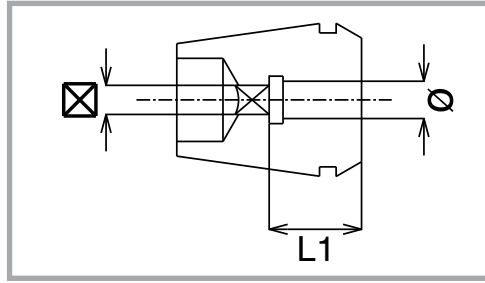

ER Tap Collets feature a unique design that incorporates an internal square drive with our popular ER Series collets. The square drive matches the tap square, providing a tight fit for all rigid tapping applications.

PART NUMBER	TAP INCH SIZE	TAP METRIC SIZE	L1	Ø	⊠
ET16-168	#8, 5/32"	M4	18.0mm	0.168	0.131
ET16-194	#10, 3/16"	M4.5, M5	18.0mm	0.194	0.152
ET16-220	#12, 7/32"	-	18.0mm	0.220	0.165
ET16-255	#14, 1/4"	M6, M6.5	18.0mm	0.255	0.191
ET20-168	#8, 5/32"	M4	18.0mm	0.168	0.131
ET20-194	#10, 3/16"	M4.5, M5	18.0mm	0.194	0.152
ET20-220	#12, 7/32"	-	18.0mm	0.220	0.165
ET20-255	#14, 1/4"	M6, M6.5	18.0mm	0.255	0.191
ET20-318	5/16"	M7, M6.5	18.0mm	0.318	0.238
ET20-323	7/16"	-	18.0mm	0.323	0.242
ET20-367	1/2"	M12, M12.5	18.0mm	0.367	0.275
ET20-381	3/8"	M10	18.0mm	0.381	0.286
ET25-168	#8, 5/32"	M4	18.0mm	0.168	0.131
ET25-194	#10, 3/16"	M4.5, M5	18.0mm	0.194	0.152
ET25-220	#12, 7/32"	-	18.0mm	0.220	0.165
ET25-255	#14, 1/4"	M6, M6.5	18.0mm	0.255	0.191
ET25-318	5/16"	M7, M6.5	18.0mm	0.318	0.238
ET25-323	7/16"	-	18.0mm	0.323	0.242
ET25-367	1/2"	M12, M12.5	18.0mm	0.367	0.275
ET25-381	3/8"	M10	18.0mm	0.381	0.286
ET25-429	9/16"	M14	22.0mm	0.429	0.322
ET25-437	1/8" NPT(L)	-	22.0mm	0.437	0.328
ET25-480	5/8"	M16	25.0mm	0.480	0.360
ET32-168	#8, 5/32"	M4	18.0mm	0.168	0.131
ET32-194	#10, 3/16"	M4.5, M5	18.0mm	0.194	0.152
ET32-220	#12, 7/32"	-	18.0mm	0.220	0.165
ET32-255	#14, 1/4"	M6, M6.5	18.0mm	0.255	0.191
ET32-318	5/16"	M7, M6.5	18.0mm	0.318	0.238
ET32-323	7/16"	-	18.0mm	0.323	0.242
ET32-367	1/2"	M12, M12.5	18.0mm	0.367	0.275
ET32-381	3/8"	M10	18.0mm	0.381	0.286
ET32-429	9/16"	M14	22.0mm	0.429	0.322
ET32-437	1/8" NPT	-	22.0mm	0.437	0.328
ET32-480	5/8"	M16	25.0mm	0.480	0.360
ET32-542	11/16"	M18	25.0mm	0.542	0.406
ET32-562	1/4" NPT	-	25.0mm	0.562	0.421
ET32-590	3/4"	-	25.0mm	0.590	0.422
ET32-652	13/16"	M20	25.0mm	0.652	0.489
ET40-255	#14, 1/4"	M6, M6.5	18.0mm	0.255	0.191
ET40-318	5/16"	M7, M6.5	18.0mm	0.318	0.238
ET40-323	7/16"	-	18.0mm	0.323	0.242
ET40-367	1/2"	M12, M12.5	18.0mm	0.367	0.275
ET40-381	3/8"	M10	18.0mm	0.381	0.286
ET40-429	9/16"	M14	22.0mm	0.429	0.322
ET40-437	1/8" NPT	-	22.0mm	0.437	0.328
ET40-480	5/8"	M16	25.0mm	0.480	0.360
ET40-542	11/16"	M18	25.0mm	0.542	0.406
ET40-562	1/4" NPT	-	25.0mm	0.562	0.421
ET40-590	3/4"	-	25.0mm	0.590	0.422
ET40-652	13/16"	M20	25.0mm	0.652	0.489
ET40-687	1/2" NPT	-	25.0mm	0.687	0.515
ET40-697	7/8"	M22	25.0mm	0.697	0.523
ET40-700	3/8" NPT	-	25.0mm	0.700	0.531
ET40-760	15/16"	M24	25.0mm	0.760	0.570
ET40-800	1"	M25	28.0mm	0.800	0.600

ER Series Tap Coolant Collets

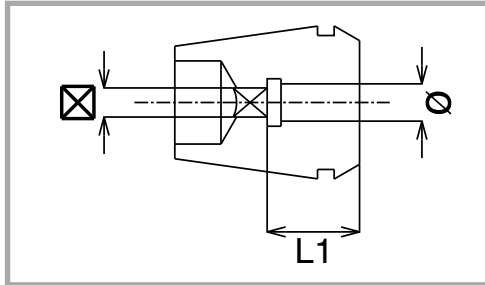

Lyndex-Nikken has now combined the versatility of our ER tapping collets with the popularity of our coolant collets to create our patented ER Coolant Tap Collets.

PART NUMBER	TAP INCH SIZE	TAP METRIC SIZE	L1	Ø	⊗
ET16-255(C)	#14, 1/4"	M6, M6.5	18.0mm	0.255	0.191
ET16-318(C)	5/16"	M7, M6.5	18.0mm	0.318	0.238
ET20-255(C)	#14, 1/4"	M6, M6.5	18.0mm	0.255	0.191
ET20-318(C)	5/16"	M7, M6.5	18.0mm	0.318	0.238
ET20-323(C)	7/16"	-	18.0mm	0.323	0.242
ET20-367(C)	1/2"	M12, M12.5	18.0mm	0.367	0.275
ET20-381(C)	3/8"	M10	18.0mm	0.381	0.286
ET25-318(C)	5/16"	M7, M6.5	18.0mm	0.318	0.238
ET25-323(C)	7/16"	-	18.0mm	0.323	0.242
ET25-367(C)	1/2"	M12, M12.5	18.0mm	0.367	0.275
ET25-381(C)	3/8"	M10	18.0mm	0.381	0.286
ET25-429(C)	9/16"	M14	22.0mm	0.429	0.322
ET25-480(C)	5/8"	M16	25.0mm	0.480	0.360
ET32-255(C)	#14, 1/4"	M6, M6.5	18.0mm	0.255	0.191
ET32-318(C)	5/16"	M7, M6.5	18.0mm	0.318	0.238
ET32-323(C)	7/16"	-	18.0mm	0.323	0.242
ET32-367(C)	1/2"	M12, M12.5	18.0mm	0.367	0.275
ET32-381(C)	3/8"	M10	18.0mm	0.381	0.286
ET32-429(C)	9/16"	M14	22.0mm	0.429	0.322
ET32-480(C)	5/8"	M16	25.0mm	0.480	0.360
ET32-542(C)	11/16"	M18	25.0mm	0.542	0.406
ET32-590(C)	3/4"	-	25.0mm	0.590	0.422
ET32-652(C)	13/16"	M20	25.0mm	0.652	0.489
ET40-323(C)	7/16"	-	18.0mm	0.323	0.242
ET40-367(C)	1/2"	M12, M12.5	18.0mm	0.367	0.275
ET40-381(C)	3/8"	M10	18.0mm	0.381	0.286
ET40-429(C)	9/16"	M14	22.0mm	0.429	0.322
ET40-480(C)	5/8"	M16	25.0mm	0.480	0.360
ET40-542(C)	11/16"	M18	25.0mm	0.542	0.406
ET40-590(C)	3/4"	-	25.0mm	0.590	0.422
ET40-652(C)	13/16"	M20	25.0mm	0.652	0.489
ET40-697(C)	7/8"	M22	25.0mm	0.697	0.523
ET40-760(C)	15/16"	M24	25.0mm	0.760	0.570
ET40-800(C)	1"	M25	28.0mm	0.800	0.600

Note: Seals up to maximum coolant pressure of 1000 PSI.

Wrench Instructions

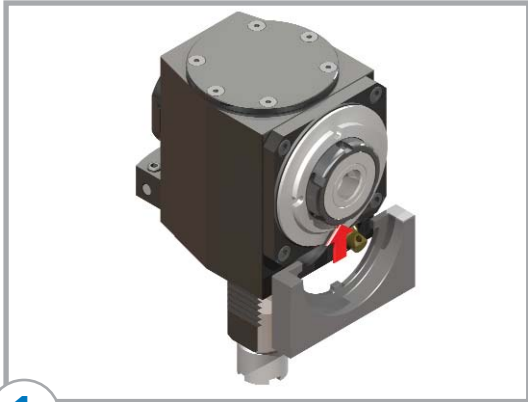

- 1** Insert setting fixture behind collet nut.

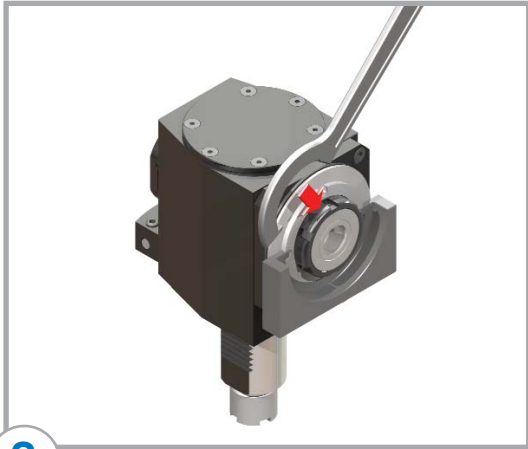

- 2** After securing the setting fixture in position, apply spanner wrench onto collet nut.

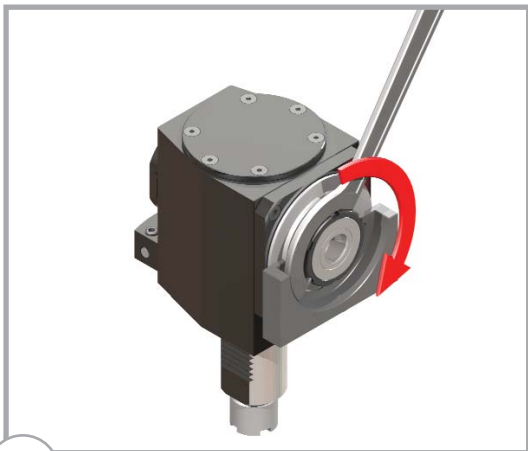

- 3** While holding the setting wrench, turn the spanner wrench clockwise to tighten.

Service and Support

Lyndex-Nikken is dedicated to providing not only the highest quality of equipment, but also the highest quality of service and customer care. With over 60 years of experience, our service engineers are looking forward to supporting your needs beyond your expectations.

We fully stock all internal components to provide an expedited and cost-effective maintenance program and rebuild package for your live tooling. Managing a maintenance schedule for all your machine tool accessory components can be challenging, so we'll be glad to remind you when the time comes.

Furthermore, to prevent an interruption in your production schedule, for certain models we can offer a "loaner" live tool while your live tool is under repair.

Warranty:

1 year warranty for internal components

2 year manufacturer warranty on external body

For any service request or inquiry, please contact our service department: (847) 367-4800

TQW Torque Wrenches



The TQW Torque Wrench is very accurate and easy-to-use, guaranteeing maximum accuracy and preventing tool overtightening or breakage.

- Variable torque adjustable wrench
- Robust and durable
- Ergonomic grip
- Easy to read inch and metric scale
- Strong steel shaft is highly corrosion resistant
- Easy to set up and operation:
 - A. Set wrench to desired torque setting
 - B. Insert attachment
 - C. Torque down on collet nut until it clicks in place



A wide selection of attachments are available: ER, SK, TG, Pull Stud, Milling Chuck, Capto

Design and Construction



A "Push-Button Locking Device" securely locks the preset torque and prevents inadvertent adjustment.

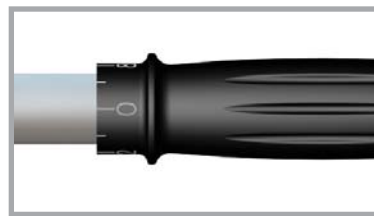

Handle is shaped to provide a firm and ergonomic grip.

Collet Number	Part Number	Attachments (Type and Size)			Torque Range		Torque Wrench	
		Description	mm	inch	lbs	Nm	Part Number	Description
ER8	TQW-ER08	Blank	Special Attachment - Call		4	6	TQW-025	14X18, 25ft.lbs
ER11	TQW-ER11(17)	Hex/OE	17	0.67	11	15		
ER16	TQW-ER16(32)	Hook	32 [+/-5mm]	1.25	40	54	TQW-150	14X18, 150ft.lbs
ER20	TQW-ER20(32)		32 [+/-5mm]	1.25	60	81		
ER25	TQW-ER25(43)		43 [+/-5mm]	1.69	75	102		
ER32	TQW-ER32(50)		50 [+/-5mm]	1.96	100	136		
ER40	TQW-ER40(63)		63 [+/-5mm]	2.48	125	169		
SK6	TQW-SK06(18)	Hex/OE	18	0.71	14	19	TQW-025	14X18, 25ft.lbs
SK10	TQW-SK10(1)		25.4	1.00	33-34	45-46		
SK16	TQW-SK16(43)	Hook	43 [+/-5mm]	1.69	55-62	74-84	TQW-150	14X18, 150ft.lbs
SK25	TQW-SK25(60)		60 [+/-5mm]	2.36	66-73	90-99		
TG75	TQW-TG075(50)	Hook	50 [+/-5mm]	1.96	55	75	TQW-150	14X18, 150ft.lbs
TG100	TQW-TG100(63)		63 [+/-5mm]	2.48	75	102		
TG150	TQW-TG150(82)		82 [+/-5mm]	3.22	100	136		
Pull-Stud-13mm	TQW-PS(13)	Hex/OE	13	0.51	14 ~ 18	19 to 25	TQW-025	14X18, 25ft.lbs
Pull-Stud-3/4 (19mm)	TQW-PS(19)		19	0.75	44 ~ 59	60 to 80	TQW-150	14X18, 150ft.lbs
Pull-Stud-30mm	TQW-PS(30)		30	1.18	147 ~ 185	200 to 250		
Pull-Stud-1.1/4	TQW-PS(32)		31.75	1/1/2004	147 ~ 185	200 to 250		
Milling Chuck 3/4"	TQW-C3/4(50)	Hook	50 [+/-5mm]	1.96	19 to 24	26-32	TQW-150	14X18, 150ft.lbs
Milling Chuck 1"	TQW-C1(60)		60 [+/-5mm]	2.36	27 to 31	36-42		
Milling Chuck 1.1/4"	TQW-C1.1/4(72)		72 [+/-5mm]	2.83	48 to 59	65-80		
Capto C3	TQW-CAPTO3(8)	Hex	8	0.31	26	35	TQW-150	14X18, 150ft.lbs
Capto C4	TQW-CAPTO4(10)		10	0.39	37	50		
Capto C5	TQW-CAPTO5(12)		12	0.47	52	70		



www.lyndexnikken.com
(800) 543-6237
CAT2010-OK-CAP