



COMPLETE METALWORKING SOLUTIONS
(800) 991-4225 www.ahbinc.com
ISO Certified customerservice@ahbinc.com

MODULAR ANGLE HEAD CATALOG



**FLEXIBILITY &
PERFORMANCE**



TABLE OF CONTENTS



**FLEXIBILITY &
PERFORMANCE**

MODULAR ANGLE HEAD SYSTEM	PAGE 3
ORDERING EXAMPLE	PAGE 4
COOLANT CONFIGURATIONS	PAGE 5
MODULAR ANGLE HEAD TAPERS	PAGES 6-10
MODULAR ANGLE HEADS	PAGES 11-29
Mimatic® MI ATTACHMENTS	PAGES 30-31
NSK ATTACHMENTS	PAGE 32
ANGLE HEAD POSITIONING PINS AND BLOCKS	PAGE 33
ER COLLETS	PAGES 34-35
FREQUENTLY ASKED QUESTIONS & NOTES	PAGES 36-37

Modular Angle Head System - Flexibility for any application!



Tapers



Taper Extension

Modular Attachments



Constructing an Angle Head in 3 easy steps!

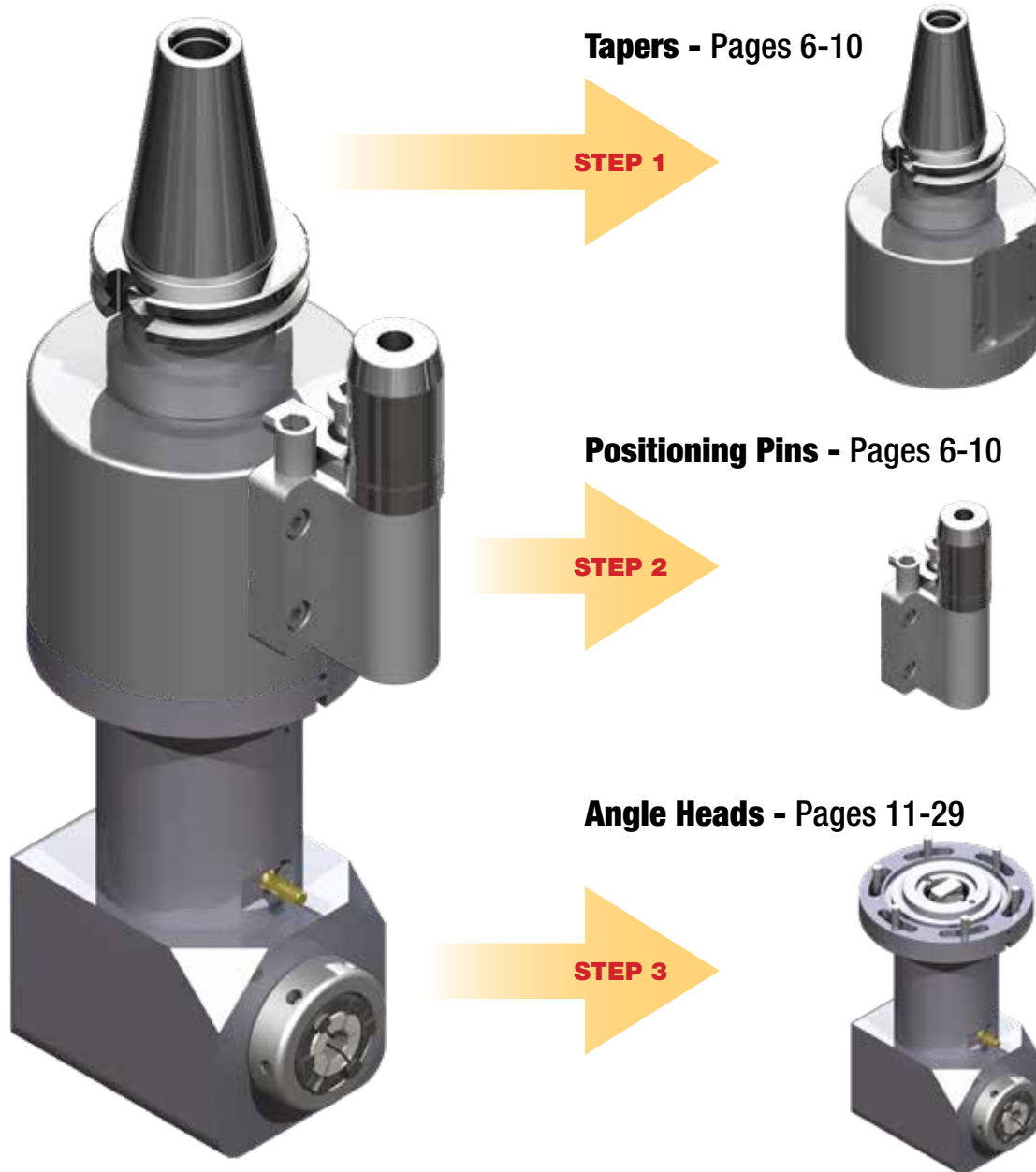

Modular Angle Head System Features

- Flexible for a multitude of applications
- Adaptable with a wide variety of machine tapers
- Bolt style mounting system between taper and modular attachment for added rigidity
- Cost effective solution when angle heads are required on machines with different tapers
- 360 degree body and head rotation
- Tapered positioning pin for alignment accuracy

Modular Attachment Features

- Slim styles for inner bore work
- Stubby styles for added milling rigidity
- Extended Length style for added reach
- Quick Change system for operations involving multiple tools
- Double output style eliminates the necessity for two heads
- NSK output for small internal engraving and light duty drilling

Coolant Configurations

COOLANT SUPPLY THROUGH THE SPINDLE



Taper Attachment
Internal Coolant Type

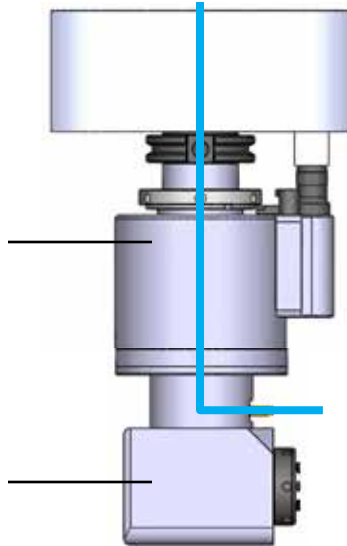

Standard Modular
Attachment

EXTERNAL COOLANT

COOLANT SUPPLY THROUGH THE POSITIONING BLOCK

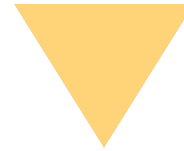

Standard Taper
Attachment

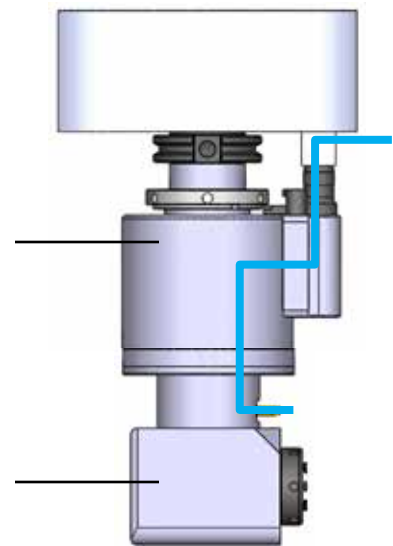

Standard Modular
Attachment

EXTERNAL COOLANT

Taper Attachment
Internal Coolant Type

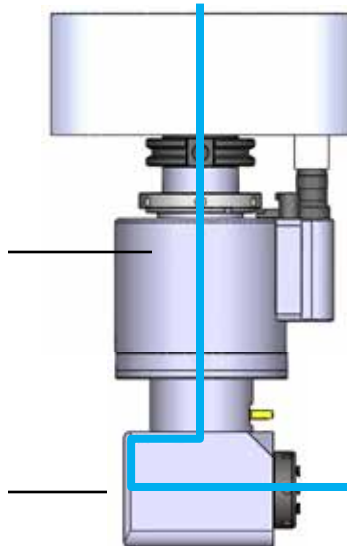

Modular Attachment
Internal Coolant Type

INTERNAL COOLANT

Standard Taper
Attachment

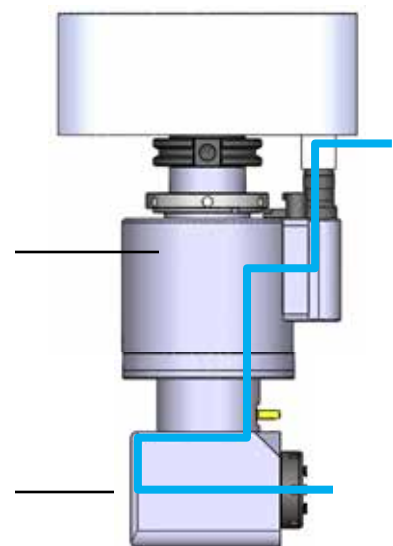

Modular Attachment
Internal Coolant Type

INTERNAL COOLANT

Tapers

CAT40



Extensions are also available, please see page 10.

Please reference page 5 for coolant configurations

Part #: C40-MRAM

C40-MRAM-IC (Internal Coolant)

mm [inch]

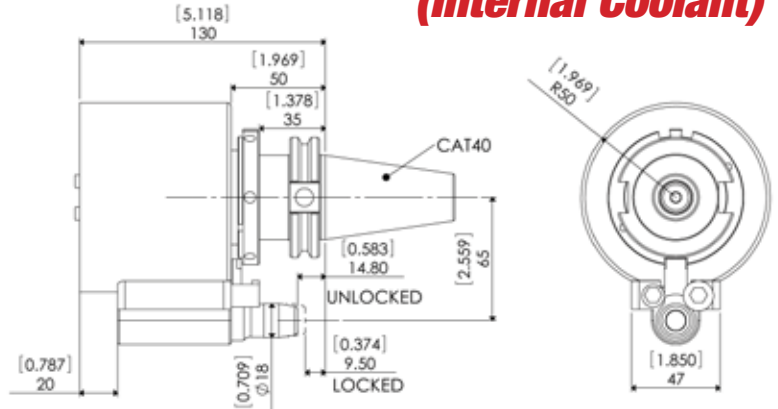

Requires positioning pin part #: PA65-CAT/BT



- 65mm (2.56") pitch positioning pin with 9.5mm (.374") below gage line is standard (Part #: PA65-CAT/BT).
- 65mm (2.56") pitch positioning pin available in different lengths upon request.

CAT50



Extensions are also available, please see page 10.

Part #: C50-MRAM

C50-MRAM-IC (Internal Coolant)

mm [inch]

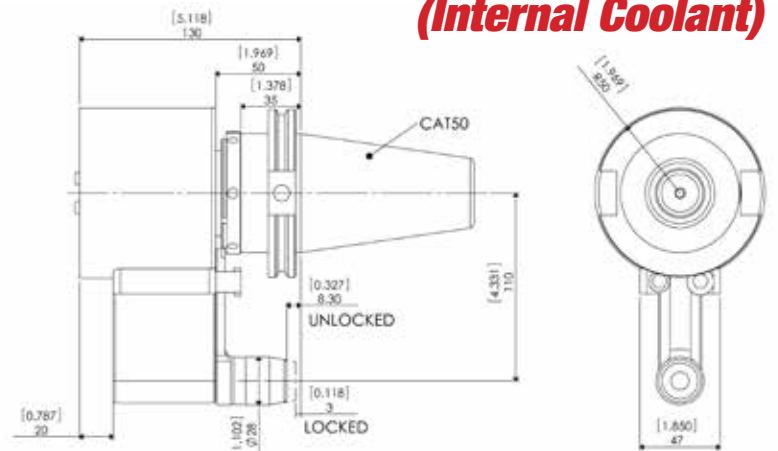

Requires positioning pin part #: PA110-CAT



- 110mm (4.33") pitch positioning pin with 3mm (.118") below gage line is standard (Part #: PA110-CAT).
- 110mm (4.33") pitch positioning pin available in different lengths upon request.
- For spindles requiring 80mm pitch:**
- 80mm (3.15") pitch positioning pin with 3mm (.118") below gage line is standard (Part #: PA80-CAT).
- 80mm (3.15") pitch positioning pin available in different lengths upon request.

Tapers

Please reference page 5 for coolant configurations

BT40



Extensions are also available, please see page 10.

Part #: B40-MRAM

B40-MRAM-IC (Internal Coolant)

mm [inch]

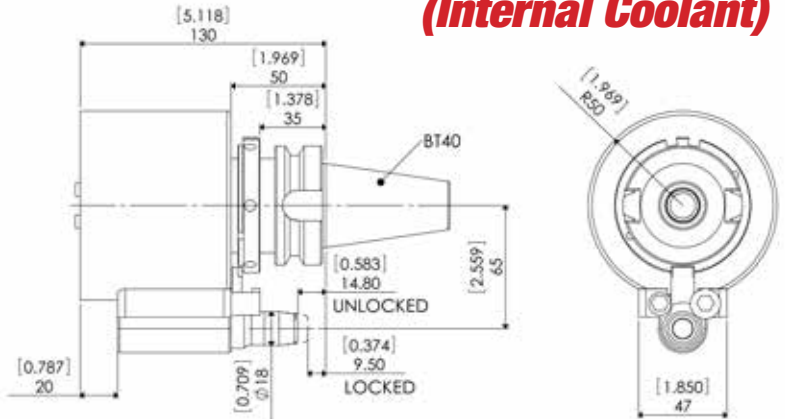

Requires positioning pin part #: PA65-CAT/BT



- 65mm (2.56") pitch positioning pin with 9.5mm (.374") below gage line is standard (Part #: PA65-CAT/BT).
- 65mm (2.56") pitch positioning pin available in different lengths upon request.

BT50



Extensions are also available, please see page 10.

Part #: B50-MRAM

B50-MRAM-IC (Internal Coolant)

mm [inch]

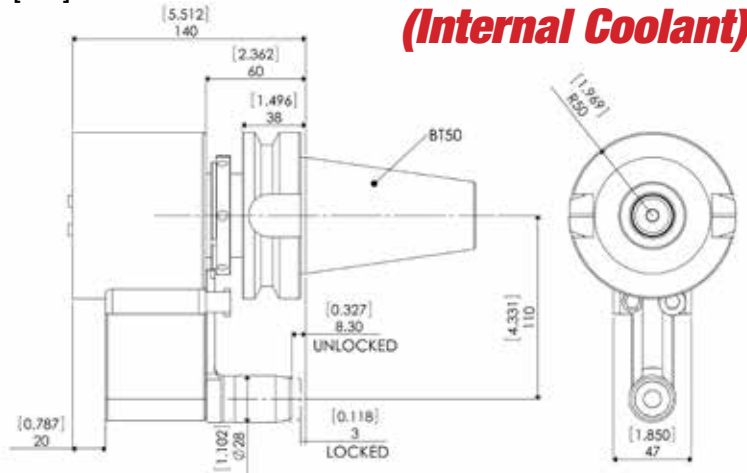

Requires positioning pin part #: PA110-BT/HSK



- 110mm (4.33") pitch positioning pin with 3mm (.118") below gage line is standard (Part #: PA110-BT/HSK).
- 110mm (4.33") pitch positioning pin available in different lengths upon request.
- For spindles requiring 80mm pitch:**
- 80mm (3.15") pitch positioning pin with 3mm (.118") below gage line is standard (Part #: PA80-BT/HSK).
- 80mm (3.15") pitch positioning pin available in different lengths upon request.

Tapers

HSK63A



Extensions are also available, please see page 10.

Please reference page 5 for coolant configurations

Part #: H63A-MRAM

H63A-MRAM-IC (Internal Coolant)

mm [inch]

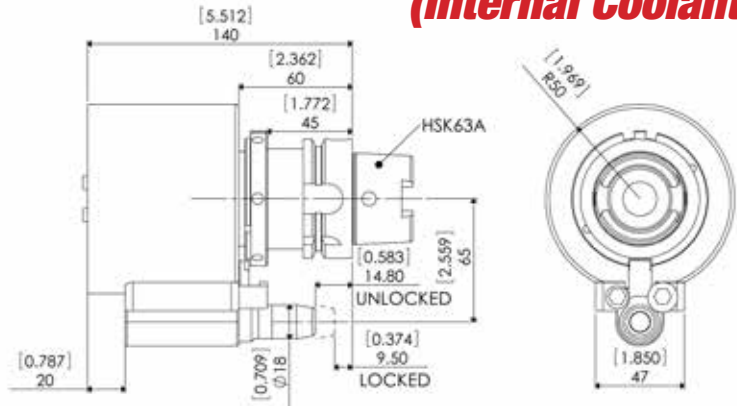

Requires positioning pin part #: PA65-HSK



- 65mm (2.56") pitch positioning pin with 9.5mm (.374") below gage line is standard (Part #: PA65-HSK).
- 65mm (2.56") pitch positioning pin available in different lengths upon request.

HSK100A



Extensions are also available, please see page 10.

Part #: H100A-MRAM

H100A-MRAM-IC (Internal Coolant)

mm [inch]

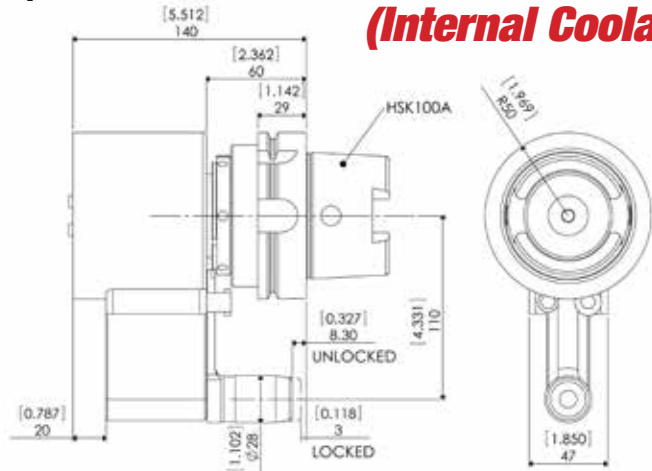

Requires positioning pin part #: PA110-BT/HSK



- 110mm (4.33") pitch positioning pin with 3mm (.118") below gage line is standard (Part #: PA110-BT/HSK).
- 110mm (4.33") pitch positioning pin available in different lengths upon request.
- For spindles requiring 80mm pitch:**
- 80mm (3.15") pitch positioning pin with 3mm (.118") below gage line is standard (Part #: PA80-BT/HSK).
- 80mm (3.15") pitch positioning pin available in different lengths upon request.

Tapers

CAPTO C6



Extensions are also available, please see page 10.

Please reference page 5 for coolant configurations

Part #: C6-MRAM

**C6-MRAM-IC
(Internal Coolant)**

mm [inch]

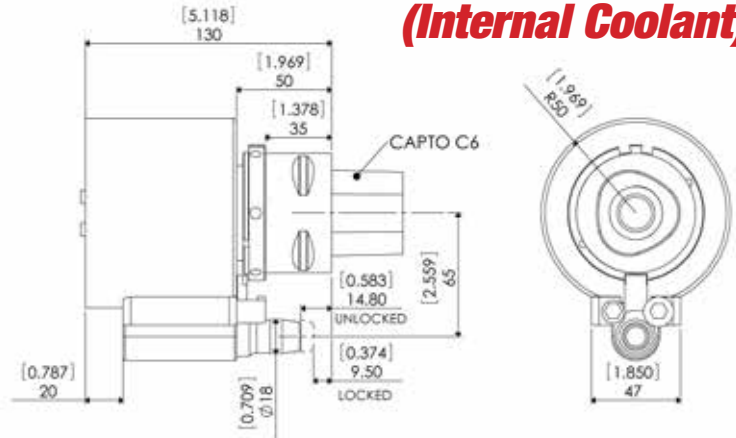

Requires positioning pin part #: PA65-CAT/BT



- 65mm (2.56") pitch positioning pin with 9.5mm (.374") below gage line is standard (Part #: PA65-CAT/BT).
- 65mm (2.56") pitch positioning pin available in different lengths upon request.

CAPTO C8



Extensions are also available, please see page 10.

Part #: C8-MRAM

**C8-MRAM-IC
(Internal Coolant)**

mm [inch]

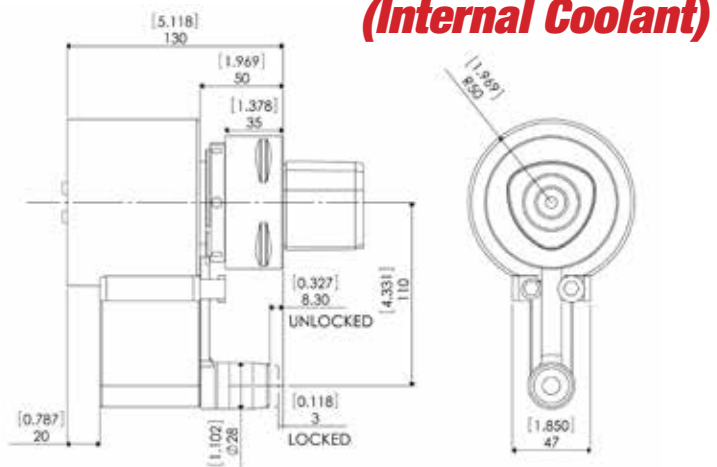

Requires positioning pin part #: PA110-CAT



- 110mm (4.33") pitch positioning pin with 3mm (.118") below gage line is standard (Part #: PA110-CAT).
- 110mm (4.33") pitch positioning pin available in different lengths upon request.
- For spindles requiring 80mm pitch:**
- 80mm (3.15") pitch positioning pin with 3mm (.118") below gage line is standard (Part #: PA80-CAT).
- 80mm (3.15") pitch positioning pin available in different lengths upon request.

Tapers

Please reference page 5 for coolant configurations

HSK80F

Part #: H80F-MRAM

H80F-MRAM-IC (Internal Coolant)



mm [inch]

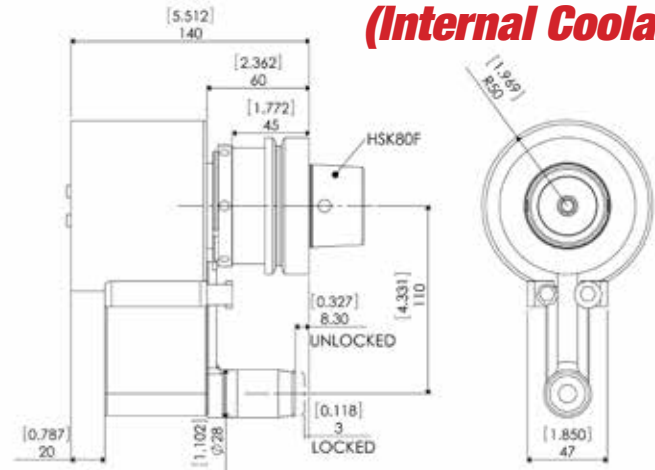

Requires positioning pin part #: PA110-BT/HSK

- 110mm (4.33") pitch positioning pin with 3mm (.118") below gage line is standard (Part #: PA110-BT/HSK).
- 110mm (4.33") pitch positioning pin available in different lengths upon request.

For spindles requiring 80mm pitch:

- 80mm (3.15") pitch positioning pin with 3mm (.118") below gage line is standard (Part #: PA80-BT/HSK).
- 80mm (3.15") pitch positioning pin available in different lengths upon request.

TAPER EXTENSIONS

Part #: MRAM-EXT-100

Part #: MRAM-EXT-200

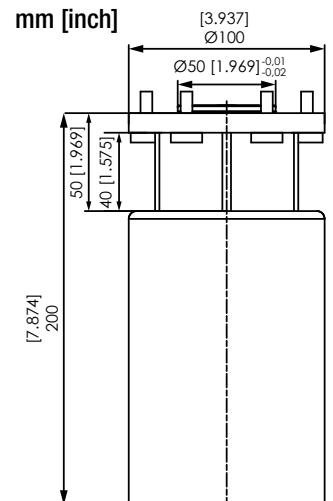
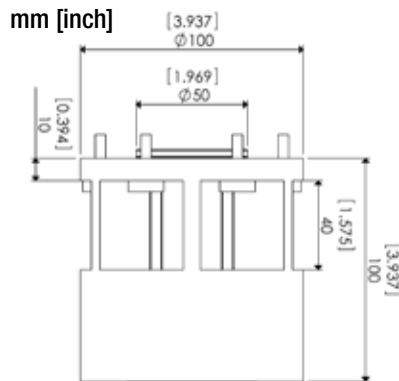

Modular Attachment - ER11 Adapter

Part #: MRAM-ER11

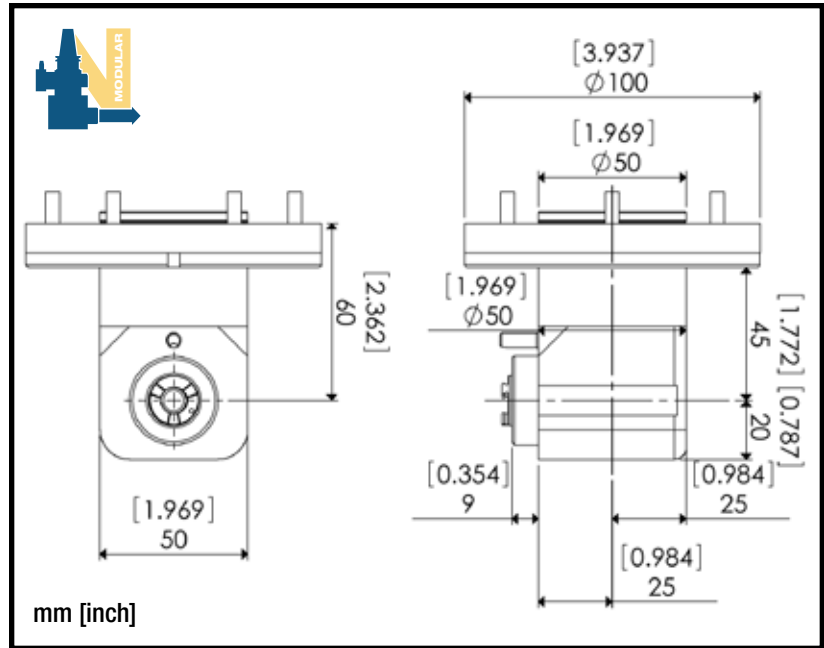

Features

- 7000 RPM
- 3 Nm Torque capable
- .019" to .275" range capable
- Recessed ER11 Nut for added clearance
- Short design makes this ideal for light milling and drilling applications
- External Coolant standard

General Taper Reference Dimensions

TAPER	A Dim (mm)	B Dim (mm)	C Dim (mm)	D Dim (mm)	E Dim (mm)	Total Weight (kg)*			
CAT40	100 (3.94")	190 (7.48")	100 (3.94")	72 (2.83")	65 (2.56")	5.2 (11.5 lbs)			
CAT50						7.6 (16.8 lbs)			
BT40						5.7 (12.6 lbs)			
BT50		8.6 (19.0 lbs)							
HSK63A		200 (7.87")				100 (3.94")	72 (2.83")	65 (2.56")	5.4 (11.9 lbs)
HSK100A									7.5 (16.5 lbs)
CAPTO C6									5.6 (12.3 lbs)
CAPTO C8		190 (7.48")				6.7 (14.8 lbs)			
HSK80F		200 (7.87")				6.4 (14.1 lbs)			

*Total weight includes tapered positioning pin, taper body and modular attachment.

General Taper Reference

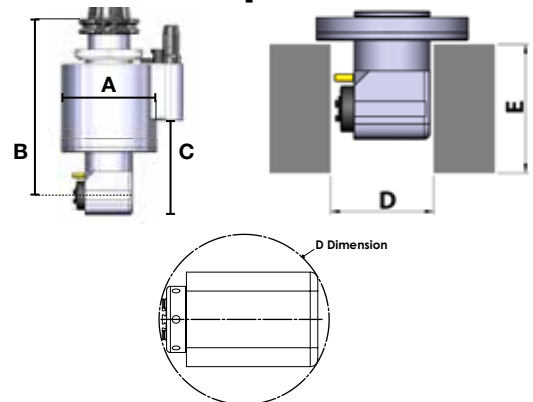

D dimension = Minimum bore diameter
E dimension = Maximum depth within bore diameter

Modular Attachment - Slim Type ER11 Adapter

Part #: MRAM-ER11ST

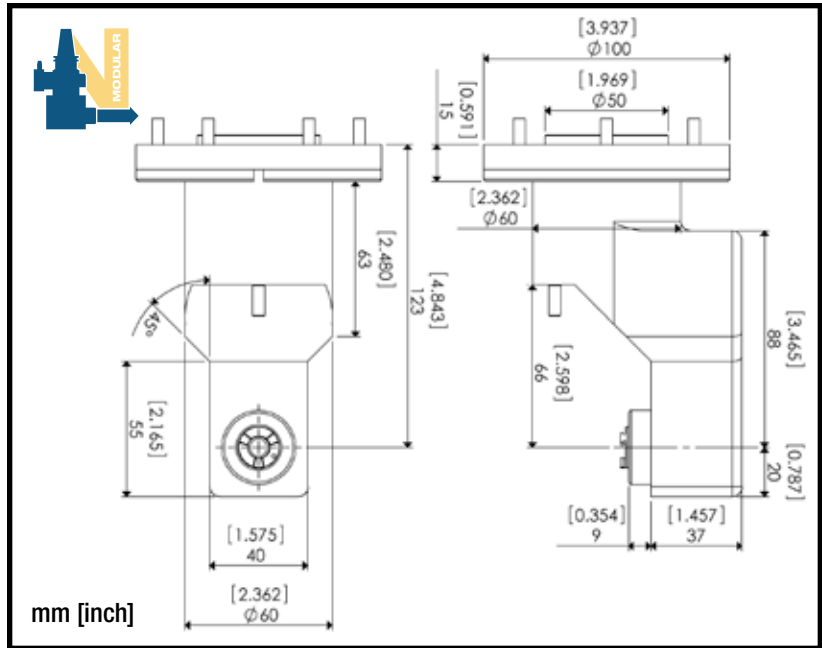

Features

- 7000 RPM
- 3 Nm Torque Capable
- .019" to .275" range capable
- Recessed ER11 Nut for added clearance
- Slim design makes this ideal for applications in internal bores or tight spaces
- External Coolant standard

General Taper Reference Dimensions

TAPER	A Dim (mm)	B Dim (mm)	C Dim (mm)	D Dim (mm)	E Dim (mm)	Total Weight (kg)*
CAT40	100 (3.94")	253 (9.96")	163 (6.42")	57 (2.24")	55 (2.17")	5.7 (12.6 lbs)
CAT50						8.1 (17.9 lbs)
BT40						6.2 (13.7 lbs)
BT50		9.1 (20.1 lbs)				
HSK63A		263 (10.35")				5.9 (13.0 lbs)
HSK100A		8.0 (17.6 lbs)				
CAPTO C6		253 (9.96")				6.1 (13.4 lbs)
CAPTO C8		7.2 (15.9 lbs)				
HSK80F		263 (10.35")				6.9 (15.2 lbs)

*Total weight includes tapered positioning pin, taper body and modular attachment.

General Taper Reference

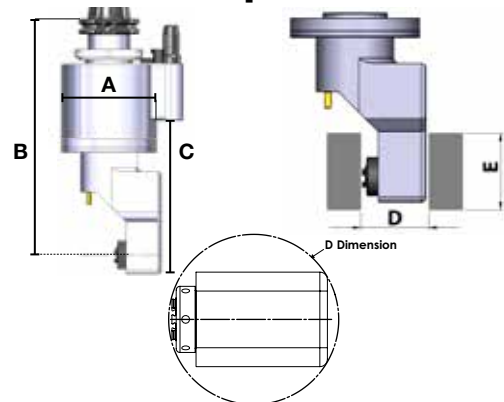

D dimension = Minimum bore diameter
E dimension = Maximum depth within bore diameter

Wrenches included: Spindle Wrench - Part# 107557



Collet Nut Wrench - Part# WRENCH-MIM-112912



For ER Collets please see pages 35-36



Modular Attachment - ER11 Adapter Long

Part #: MRAM-ER11L

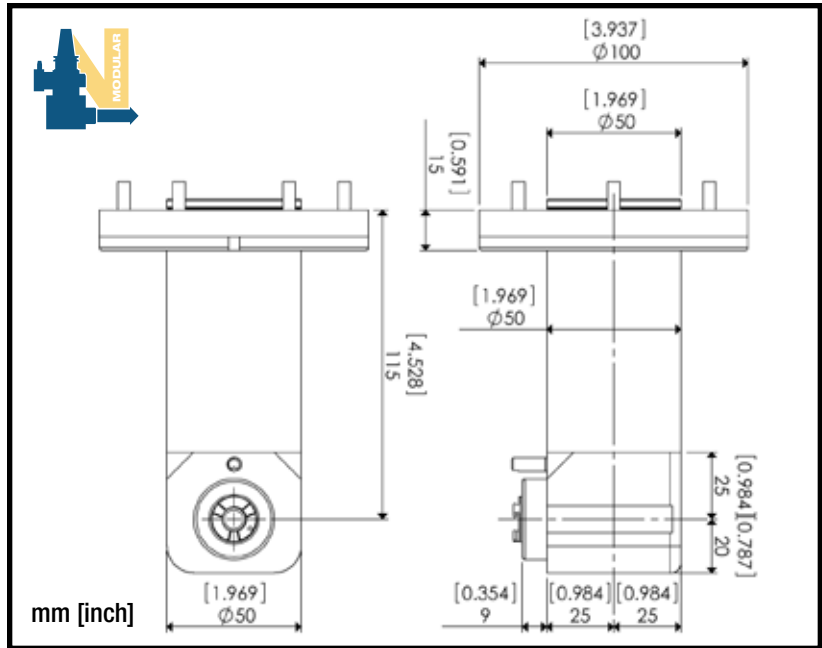

Features

- 7000 RPM
- 3 Nm Torque Capable
- .019" to .275" range capable
- Recessed ER11 Nut for added clearance
- Slim design makes this ideal for applications in internal bores or tight spaces
- External Coolant standard

General Taper Reference Dimensions

TAPER	A Dim (mm)	B Dim (mm)	C Dim (mm)	D Dim (mm)	E Dim (mm)	Total Weight (kg)*
CAT40	100 (3.94")	245 (9.65")	155 (6.10")	72 (2.83")	120 (4.72")	5.5 (12.1 lbs)
CAT50						7.9 (17.4 lbs)
BT40		255 (10.04")				6.0 (13.2 lbs)
BT50						8.9 (19.6 lbs)
HSK63A		5.7 (12.6 lbs)				
HSK100A		7.8 (17.2 lbs)				
CAPTO C6		245 (9.65")				5.9 (13.0 lbs)
CAPTO C8		7.0 (15.4 lbs)				
HSK80F		255 (10.04")				6.7 (14.8 lbs)

*Total weight includes tapered positioning pin, taper body and modular attachment.

General Taper Reference

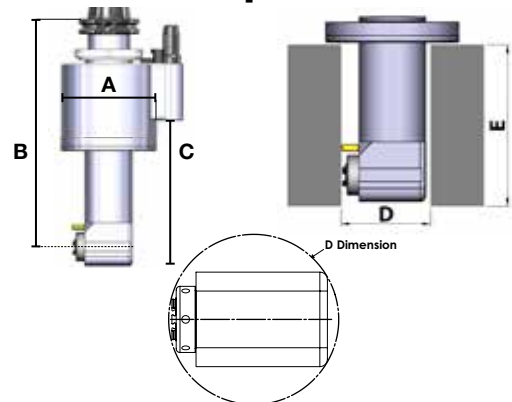

D dimension = Minimum bore diameter
E dimension = Maximum depth within bore diameter



Modular Attachment - ER16 Adapter

Part #: MRAM-ER16
MRAM-ER16-IC
(Internal Coolant)

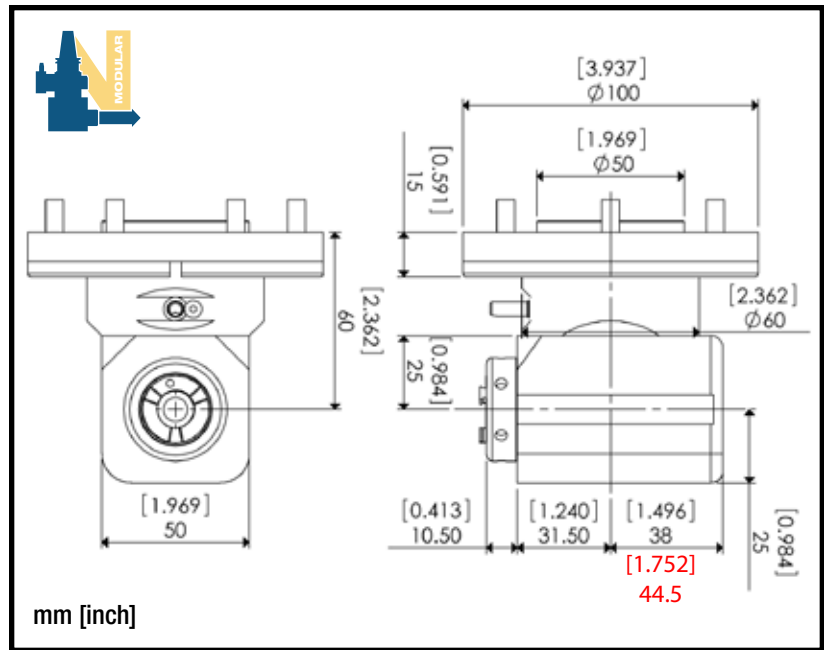

Larger dimension due to coolant-thru channel plate

Features

- 6000 RPM
- 10 Nm Torque Capable
- .039" to .393" range capable
- Recessed ER16 Nut for added clearance
- Short design makes this ideal for milling and drilling applications
- External Coolant standard
- Internal Coolant available
(PART #: MRAM-ER16-IC)

General Taper Reference Dimensions

TAPER	A Dim (mm)	B Dim (mm)	C Dim (mm)	D Dim (mm)	E Dim (mm)	Total Weight (kg)*
CAT40	100 (3.94")	190 (7.48")	105 (4.13")	90 (3.54") 100 (3.94")*	70 (2.76")	5.2 (11.5 lbs)
CAT50						7.6 (16.8 lbs)
BT40		5.7 (12.6 lbs)				
BT50		8.6 (19.0 lbs)				
HSK63A		200 (7.87")				5.4 (11.9 lbs)
HSK100A		7.5 (16.5 lbs)				
CAPTO C6		190 (7.48")				5.6 (12.3 lbs)
CAPTO C8		6.7 (14.8 lbs)				
HSK80F		200 (7.87")				6.4 (14.1 lbs)

*Total weight includes tapered positioning pin, taper body and modular attachment.

*Internal Coolant version

General Taper Reference

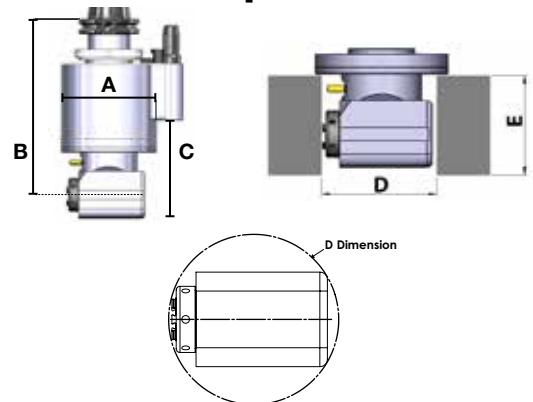

D dimension = Minimum bore diameter
E dimension = Maximum depth within bore diameter

Wrenches included: Spindle Wrench - Part# 107557

Collet Nut Wrench - Part# WRENCH-MIM-112954

For ER Collets please see pages 35-36

Modular Attachment - Slim Type ER16 Adapter

Part #: MRAM-ER16ST

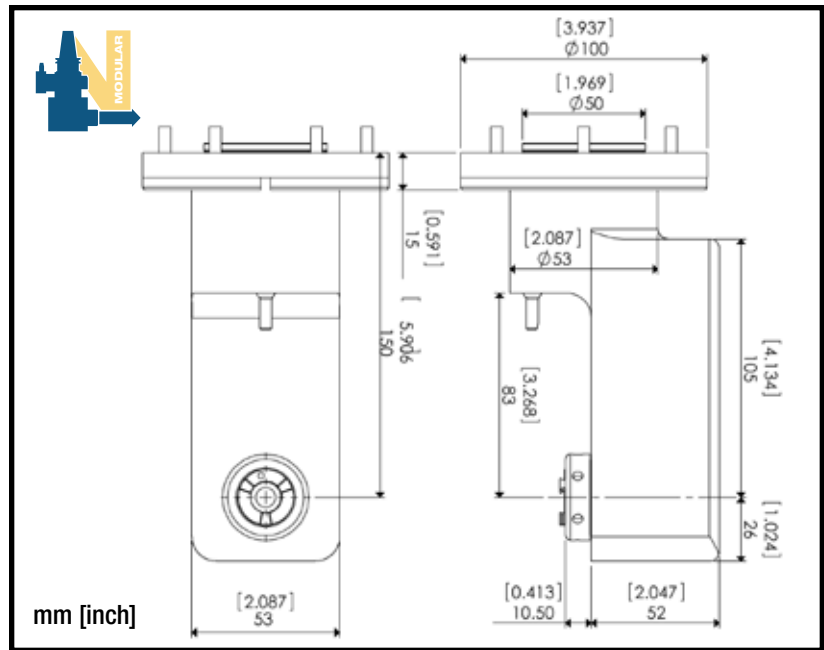

Features

- 6000 RPM
- 10 Nm Torque Capable
- .039" to .393" range capable
- Recessed ER16 Nut for added clearance
- Slim design makes this ideal for applications in internal bores or tight places
- External Coolant standard

General Taper Reference Dimensions

TAPER	A Dim (mm)	B Dim (mm)	C Dim (mm)	D Dim (mm)	E Dim (mm)	Total Weight (kg)*
CAT40	100 (3.94")	270 (10.63")	186 (7.32")	78 (3.07")	99 (3.90")	6.5 (14.3 lbs)
CAT50						8.9 (19.6 lbs)
BT40		7.0 (15.4 lbs)				
BT50		9.9 (21.8 lbs)				
HSK63A	100 (3.94")	280 (11.02")	186 (7.32")	78 (3.07")	99 (3.90")	6.7 (14.8 lbs)
HSK100A						8.8 (19.4 lbs)
CAPTO C6	270 (10.63")	6.9 (15.2 lbs)				
CAPTO C8		8.0 (17.6 lbs)				
HSK80F	280 (11.02")	7.7 (17.0 lbs)				

*Total weight includes tapered positioning pin, taper body and modular attachment.

General Taper Reference

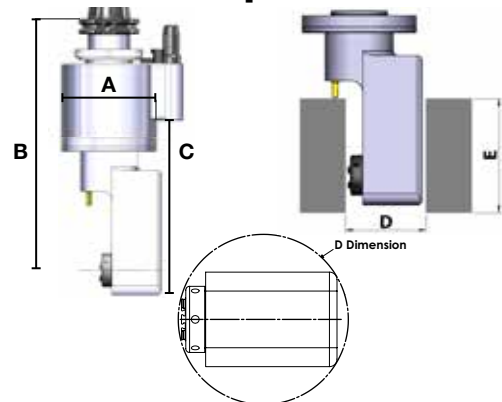

D dimension = Minimum bore diameter
E dimension = Maximum depth within bore diameter

Wrenches included: Spindle Wrench - Part# 107557



Collet Nut Wrench - Part# WRENCH-MIM-112954



For ER Collets please see pages 35-36



Modular Attachment - ER16 Adapter Long

Part #: MRAM-ER16L

MRAM-ER16L-IC (Internal Coolant)

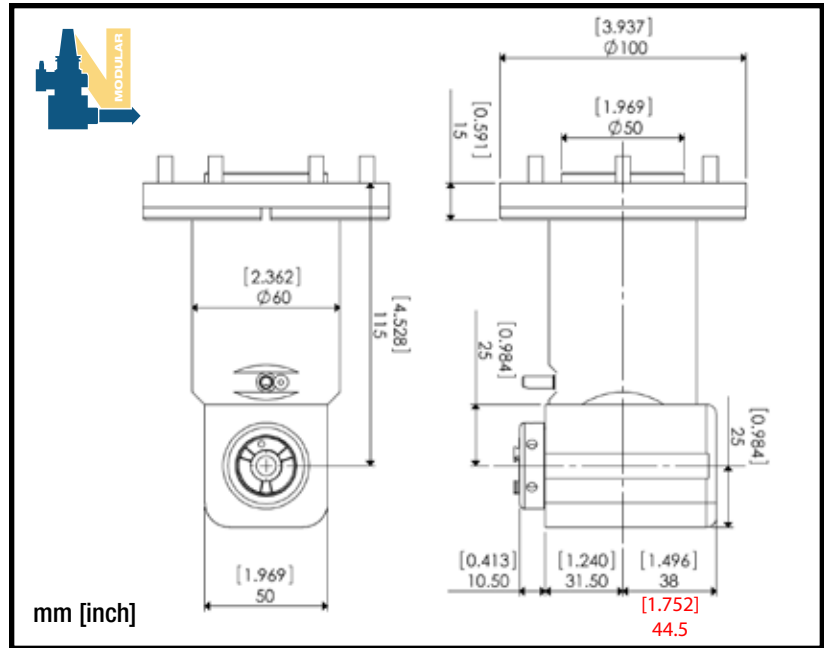

Larger dimension due to coolant-thru channel plate

Features

- 6000 RPM
- 10 Nm Torque Capable
- .039" to .393" range capable
- Recessed ER16 Nut for added clearance
- Extended reach design is ideal for hard to reach applications around fixtures, or beyond machine table beds
- External Coolant standard
- Internal Coolant available
(PART #: MRAM-ER16L-IC)

General Taper Reference Dimensions

TAPER	A Dim (mm)	B Dim (mm)	C Dim (mm)	D Dim (mm)	E Dim (mm)	Total Weight (kg)*			
CAT40	100 (3.94")	245 (9.65")	160 (6.30")	90 (3.54")	125 (4.92")	7.4 (16.3 lbs)			
CAT50						9.8 (21.6 lbs)			
BT40						7.9 (17.4 lbs)			
BT50		10.8 (23.8 lbs)							
HSK63A		255 (10.04")				160 (6.30")	100 (3.94")*	125 (4.92")	7.6 (16.8 lbs)
HSK100A									9.7 (21.4 lbs)
CAPTO C6									7.8 (17.2 lbs)
CAPTO C8		245 (9.65")				160 (6.30")	100 (3.94")*	125 (4.92")	8.9 (19.6 lbs)
HSK80F		255 (10.04")				160 (6.30")	100 (3.94")*	125 (4.92")	8.6 (19.0 lbs)

*Total weight includes tapered positioning pin, taper body and modular attachment.

*Internal Coolant version

General Taper Reference

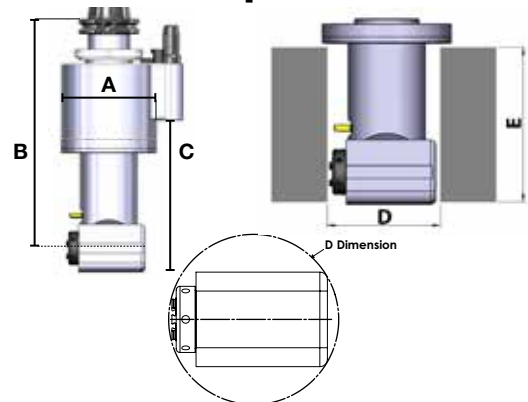

D dimension = Minimum bore diameter
E dimension = Maximum depth within bore diameter

Modular Attachment - ER20 Adapter

Part #: MRAM-ER20 MRAM-ER20-IC (Internal Coolant)

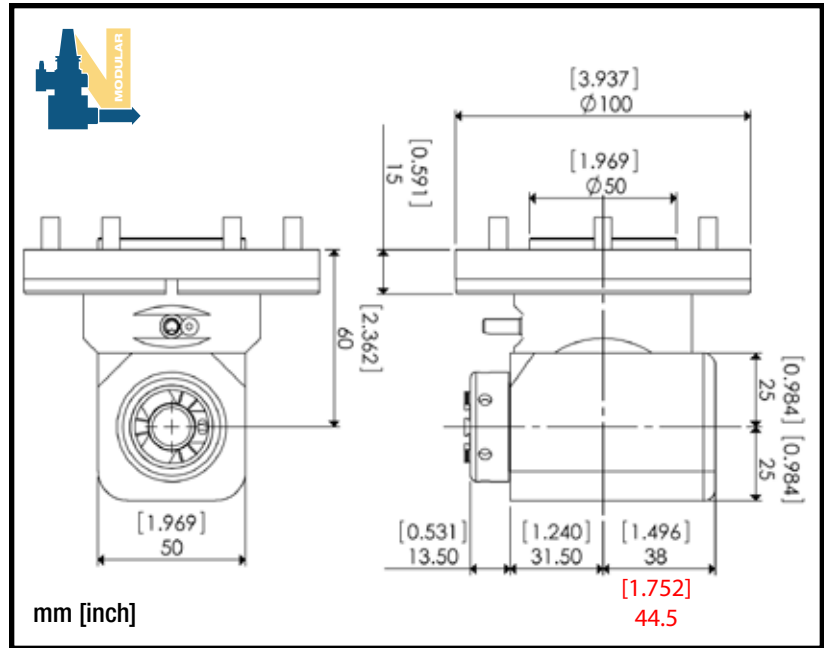

Larger dimension due to coolant-thru channel plate

Features

- 6000 RPM
- 10 Nm Torque Capable
- .039" to .511" range capable
- Recessed ER20 Nut for added clearance
- Short design makes this ideal for milling and drilling applications
- External Coolant standard
- Internal Coolant available
(PART #: MRAM-ER20-IC)

General Taper Reference Dimensions

TAPER	A Dim (mm)	B Dim (mm)	C Dim (mm)	D Dim (mm)	E Dim (mm)	Total Weight (kg)*
CAT40	100 (3.94")	190 (7.48")	105 (4.13")	93 (3.66") 103 (4.06")*	70 (2.76")	5.4 (11.9 lbs)
CAT50						7.8 (17.2 lbs)
BT40		5.9 (13.0 lbs)				
BT50		8.8 (19.4 lbs)				
HSK63A		200 (7.87")				5.6 (12.3 lbs)
HSK100A		7.5 (16.5 lbs)				
CAPTO C6		190 (7.48")				5.8 (12.8 lbs)
CAPTO C8		6.9 (15.2 lbs)				
HSK80F		200 (7.87")				6.6 (14.5 lbs)

*Total weight includes tapered positioning pin, taper body and modular attachment.

*Internal Coolant version

General Taper Reference

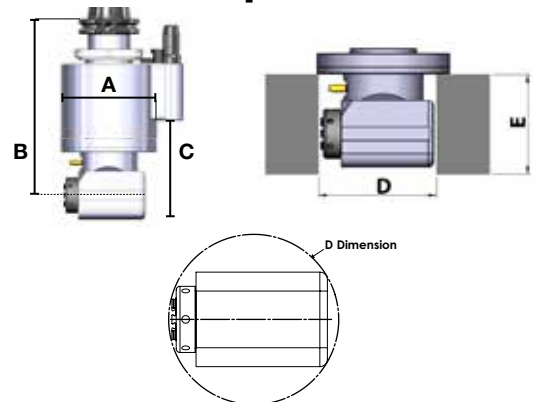

D dimension = Minimum bore diameter
E dimension = Maximum depth within bore diameter

Wrenches included: Spindle Wrench - Part# 107608

Collet Nut Wrench - Part# WRENCH-MIM-112929

For ER Collets please see pages 35-36

Modular Attachment - Slim Type ER20 Adapter

Part #: MRAM-ER20ST

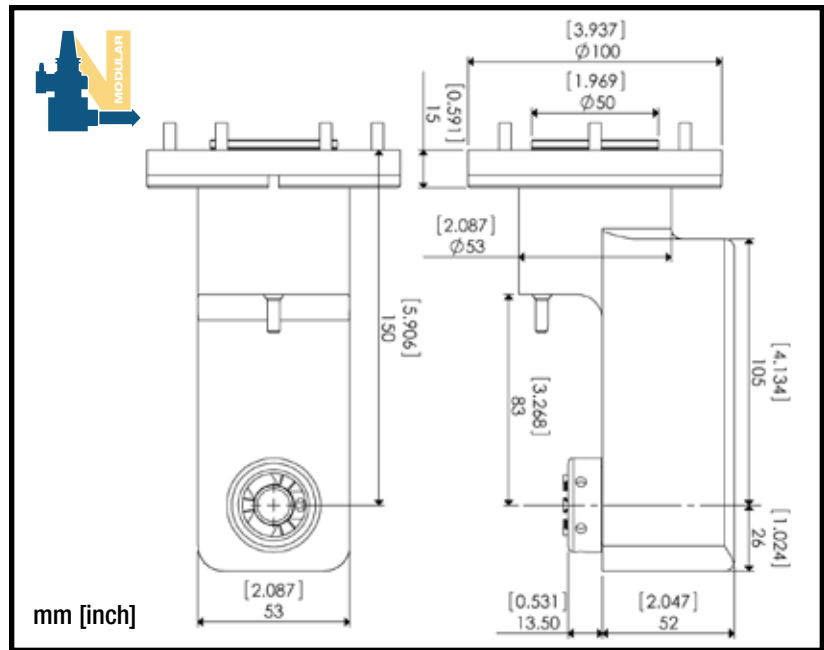

Features

- 6000 RPM
- 10 Nm Torque Capable
- .039" to .511" range capable
- Recessed ER20 Nut for added clearance
- Slim design makes this ideal for applications in internal bores or tight places
- External Coolant standard

General Taper Reference Dimensions

TAPER	A Dim (mm)	B Dim (mm)	C Dim (mm)	D Dim (mm)	E Dim (mm)	Total Weight (kg)*
CAT40	100 (3.94")	270 (10.63")	186 (7.32")	81 (3.19")	99 (3.90")	6.5 (14.3 lbs)
CAT50						8.9 (19.6 lbs)
BT40		7.0 (15.4 lbs)				
BT50		9.9 (21.8 lbs)				
HSK63A	100 (3.94")	280 (11.02")	186 (7.32")	81 (3.19")	99 (3.90")	6.7 (14.8 lbs)
HSK100A						8.8 (19.4 lbs)
CAPTO C6						6.9 (15.2 lbs)
CAPTO C8	100 (3.94")	270 (10.63")	186 (7.32")	81 (3.19")	99 (3.90")	8.0 (17.6 lbs)
HSK80F						280 (11.02")

*Total weight includes tapered positioning pin, taper body and modular attachment.

General Taper Reference

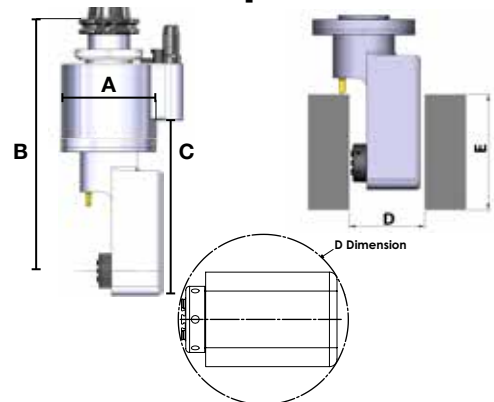

D dimension = Minimum bore diameter
E dimension = Maximum depth within bore diameter



Modular Attachment - ER20 Adapter Long

Part #: MRAM-ER20L

MRAM-ER20L-IC (Internal Coolant)

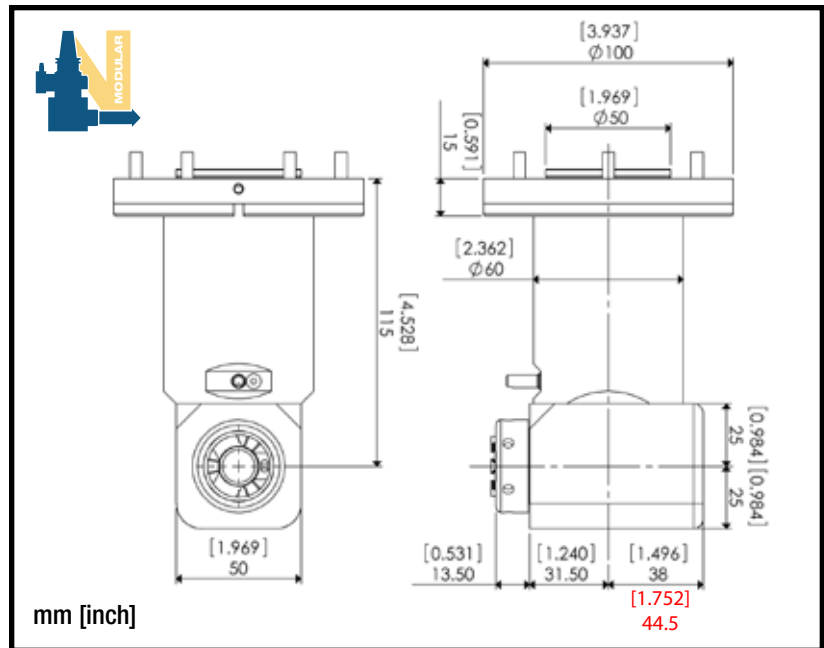

Larger dimension due to coolant-thru channel plate

Features

- 6000 RPM
- 10 Nm Torque Capable
- .039" to .511" range capable
- Recessed ER20 Nut for added clearance
- Extended reach design is ideal for hard to reach applications around fixtures, or beyond machine table beds
- External Coolant standard
- Internal Coolant available
(PART #: MRAM-ER20L-IC)

General Taper Reference Dimensions

TAPER	A Dim (mm)	B Dim (mm)	C Dim (mm)	D Dim (mm)	E Dim (mm)	Total Weight (kg)*
CAT40	100 (3.94")	245 (9.65")	160 (6.30")	93 (3.66")	125 (4.92")	7.6 (16.8 lbs)
CAT50						10 (22.0 lbs)
BT40		8.1 (17.9 lbs)				
BT50		11 (24.2 lbs)				
HSK63A		255 (10.04")				7.8 (17.2 lbs)
HSK100A		9.9 (21.8 lbs)				
CAPTO C6		245 (9.65")				8.0 (17.6 lbs)
CAPTO C8		9.1 (20.1 lbs)				
HSK80F		255 (10.04")				8.8 (19.4 lbs)

*Total weight includes tapered positioning pin, taper body and modular attachment.

*Internal Coolant version

General Taper Reference

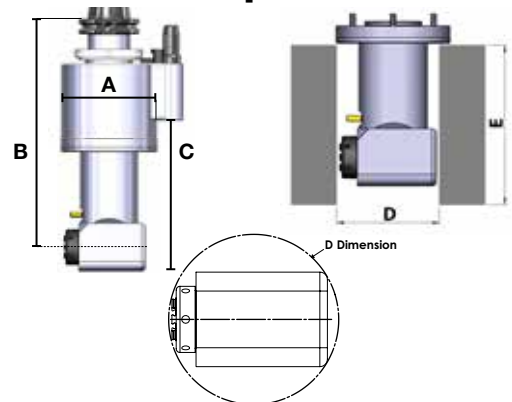

D dimension = Minimum bore diameter
E dimension = Maximum depth within bore diameter

Wrenches included: Spindle Wrench - Part# 107608



Collet Nut Wrench - Part# WRENCH-MIM-112929



For ER Collets please see pages 35-36



Modular Attachment - ER25 Adapter

Part #: MRAM-ER25 MRAM-ER25-IC (Internal Coolant)

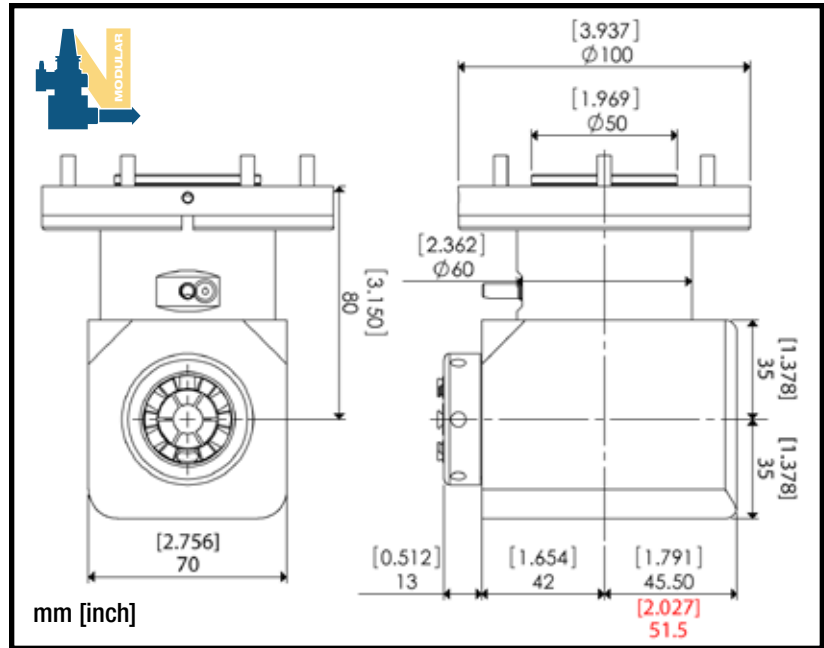

Larger dimension due to coolant-thru channel plate

Features

- 5000 RPM
- 25 Nm Torque Capable
- .039" to .629" range capable
- Recessed ER25 Nut for added clearance
- Short design makes this ideal for milling and drilling applications
- External Coolant standard
- Internal Coolant available (PART #: MRAM-ER25-IC)

General Taper Reference Dimensions

TAPER	A Dim (mm)	B Dim (mm)	C Dim (mm)	D Dim (mm)	E Dim (mm)	Total Weight (kg)*	
CAT40	100 (3.94")	210 (8.27")	134 (5.28")	115 (4.53")	134 (5.28")	6.8 (15.0 lbs)	
CAT50						9.2 (20.3 lbs)	
BT40		220 (8.66")				130 (5.12")*	7.3 (16.1 lbs)
BT50							10.2 (22.5 lbs)
HSK63A		7.0 (15.4 lbs)					
HSK100A		9.1 (20.1 lbs)					
CAPTO C6		210 (8.27")				7.2 (15.9 lbs)	
CAPTO C8		8.3 (18.3 lbs)					
HSK80F		220 (8.66")				8.0 (17.6 lbs)	

*Total weight includes tapered positioning pin, taper body and modular attachment.

*Internal Coolant version

General Taper Reference

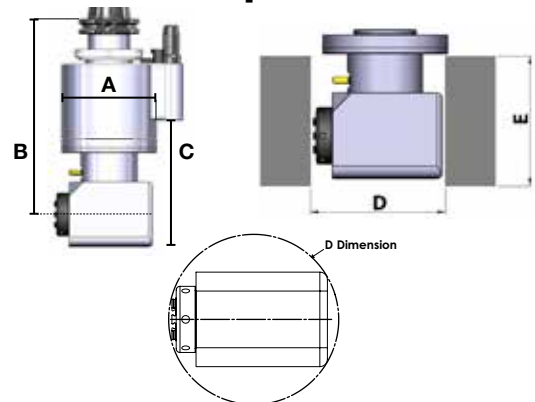

D dimension = Minimum bore diameter
E dimension = Maximum depth within bore diameter

Wrenches included: Spindle Wrench - Part# 107446

Collet Nut Wrench - Part# WRENCH-MIM-112913

For ER Collets please see pages 35-36

Modular Attachment - Slim Type ER25 Adapter

Part #: MRAM-ER25ST

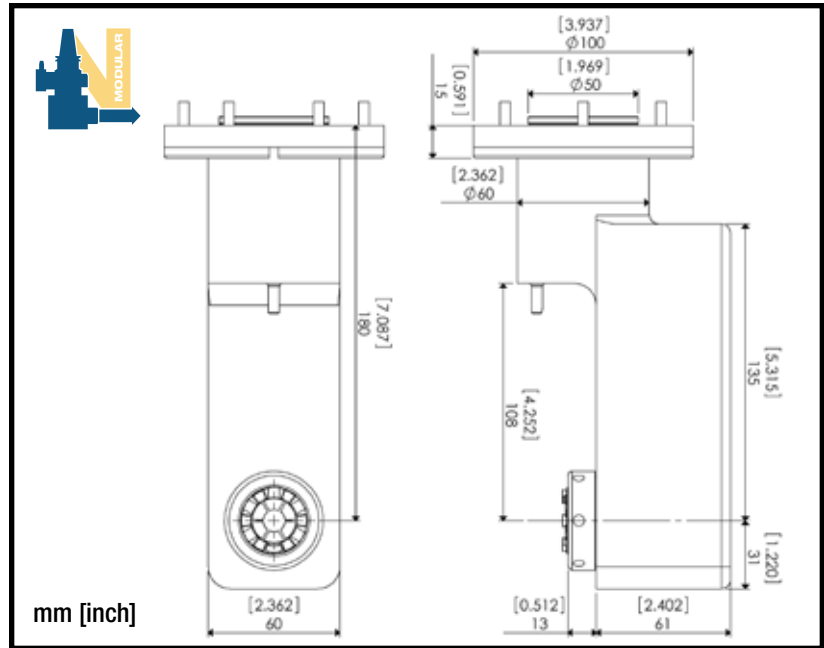

Features

- 5000 RPM
- 25 Nm Torque Capable
- .039" to .629" range capable
- Recessed ER25 Nut for added clearance
- Slim design makes this ideal for applications in internal bores or tight places
- External Coolant standard

General Taper Reference Dimensions

TAPER	A Dim (mm)	B Dim (mm)	C Dim (mm)	D Dim (mm)	E Dim (mm)	Total Weight (kg)*
CAT40	100 (3.94")	310 (12.20")	231 (9.09")	90 (3.54")	129 (5.08")	7.5 (16.5 lbs)
CAT50						9.9 (21.8 lbs)
BT40						8.0 (17.6 lbs)
BT50		10.9 (24 lbs)				
HSK63A		320 (12.60")				7.7 (17.0 lbs)
HSK100A						9.8 (21.6 lbs)
CAPTO C6		310 (12.20")				7.9 (17.4 lbs)
CAPTO C8						9.0 (19.8 lbs)
HSK80F						320 (12.60")

*Total weight includes tapered positioning pin, taper body and modular attachment.

General Taper Reference

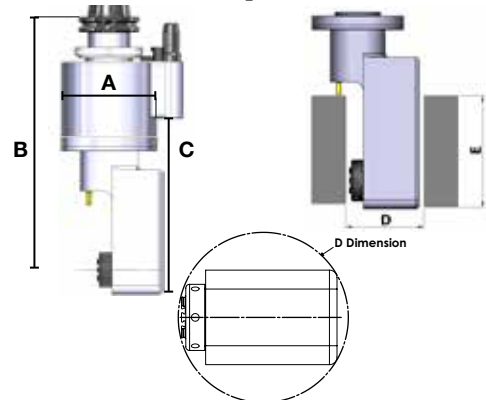

D dimension = Minimum bore diameter
E dimension = Maximum depth within bore diameter



Modular Attachment - ER25 Adapter Long

Part #: MRAM-ER25L

MRAM-ER25L-IC (Internal Coolant)

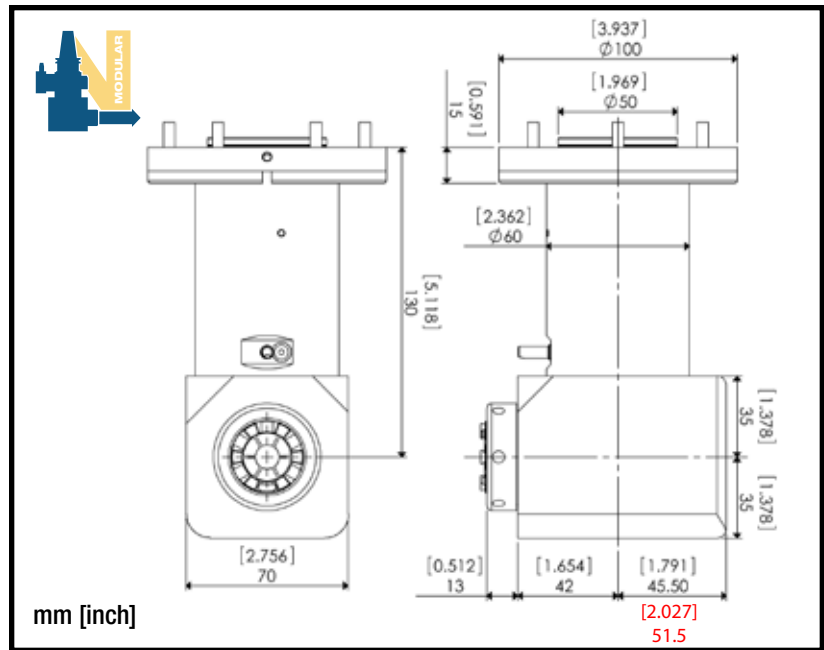

Larger dimension due to coolant-thru channel plate

Features

- 5000 RPM
- 25 Nm Torque Capable
- .039" to .629" range capable
- Recessed ER25 Nut for added clearance
- Extended reach design is ideal for hard to reach applications around fixtures, or beyond machine table beds
- External Coolant standard
- Internal Coolant available
(PART #: MRAM-ER25L-IC)

General Taper Reference Dimensions

TAPER	A Dim (mm)	B Dim (mm)	C Dim (mm)	D Dim (mm)	E Dim (mm)	Total Weight (kg)*
CAT40	100 (3.94")	260 (10.24")	185 (7.28")	115 (4.53")	185 (7.28")	7.2 (15.9 lbs)
CAT50						9.6 (21.2 lbs)
BT40		270 (10.63")				7.7 (17.0 lbs)
BT50						10.6 (23.4 lbs)
HSK63A		7.4 (16.3 lbs)				
HSK100A		9.5 (20.9 lbs)				
CAPTO C6		260 (10.24")				7.6 (16.8 lbs)
CAPTO C8		270 (10.63")				8.7 (19.2 lbs)
HSK80F		270 (10.63")				8.4 (18.5 lbs)

*Total weight includes tapered positioning pin, taper body and modular attachment.

*Internal Coolant version

General Taper Reference

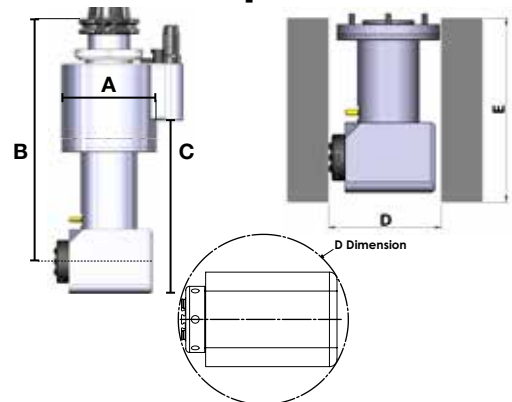

D dimension = Minimum bore diameter
E dimension = Maximum depth within bore diameter

Wrenches included: Spindle Wrench - Part# 107446



Collet Nut Wrench - Part# WRENCH-MIM-112913



For ER Collets please see pages 35-36



Modular Attachment - ER16 Adapter Double Angle Head

Part #: MRAM-ER16TS

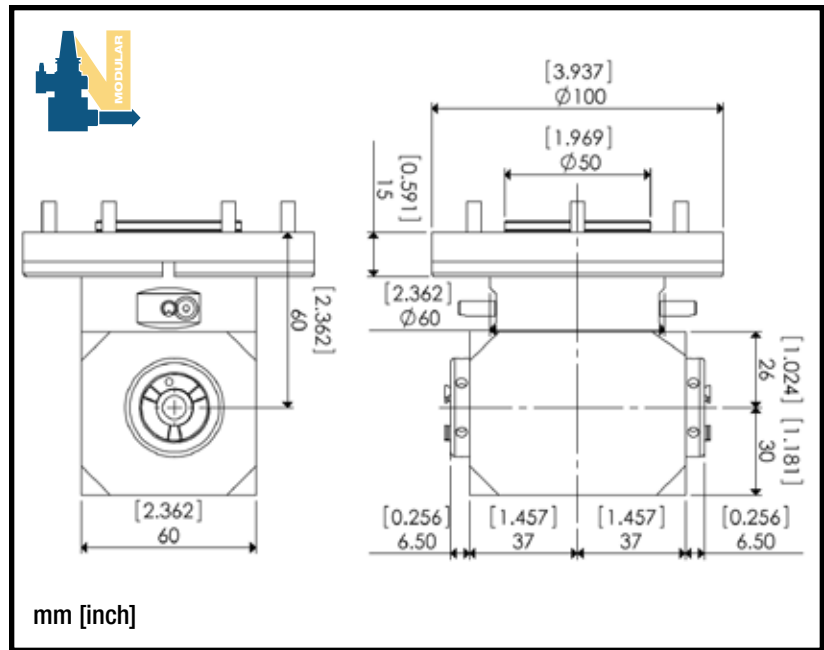

Features

- 6000 RPM
- 10 Nm Torque Capable
- .039" to .393" range capable
- Recessed ER16 Nut for added clearance
- Double sided angle head work for applications requiring the same machined feature on both sides of a part
- External Coolant standard

General Taper Reference Dimensions

TAPER	A Dim (mm)	B Dim (mm)	C Dim (mm)	D Dim (mm)	E Dim (mm)	Total Weight (kg)*
CAT40	100 (3.94")	190 (7.48")	110 (4.33")	97 (3.82")	75 (2.95")	6.0 (13.2 lbs)
CAT50						8.4 (18.5 lbs)
BT40		6.5 (14.3 lbs)				
BT50		9.4 (20.7 lbs)				
HSK63A	100 (3.94")	200 (7.87")	110 (4.33")	97 (3.82")	75 (2.95")	6.2 (13.7 lbs)
HSK100A						8.3 (18.3 lbs)
CAPTO C6	100 (3.94")	190 (7.48")	110 (4.33")	97 (3.82")	75 (2.95")	6.4 (14.1 lbs)
CAPTO C8						7.5 (16.5 lbs)
HSK80F		200 (7.87")				7.2 (15.9 lbs)

*Total weight includes tapered positioning pin, taper body and modular attachment.

General Taper Reference

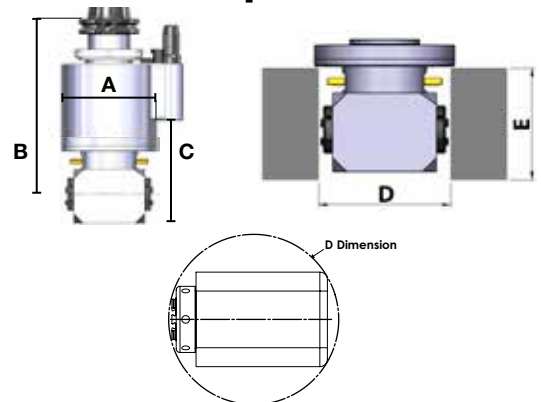

D dimension = Minimum bore diameter
E dimension = Maximum depth within bore diameter



Modular Attachment - ER25 Adapter Double Angle Head

Part #: MRAM-ER25TS

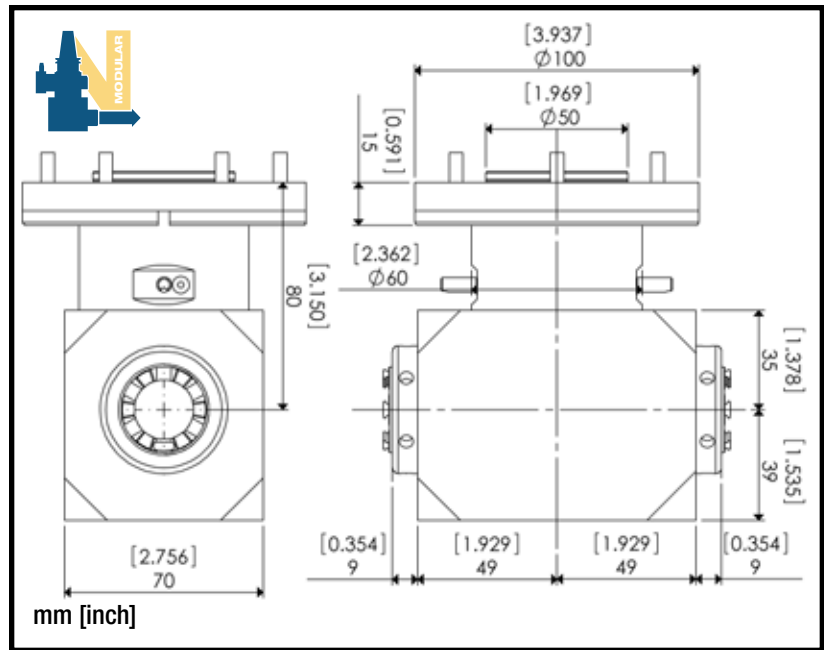

Features

- 5000 RPM
- 25 Nm Torque Capable
- .039" to .629" range capable
- Recessed ER25 Nut for added clearance
- Double sided angle head work for applications requiring the same machined feature on both sides of a part
- External Coolant standard

General Taper Reference Dimensions

TAPER	A Dim (mm)	B Dim (mm)	C Dim (mm)	D Dim (mm)	E Dim (mm)	Total Weight (kg)*
CAT40	100 (3.94")	210 (8.27")	139 (5.47")	125 (4.92")	139 (5.47")	7.2 (15.9 lbs)
CAT50						9.6 (21.2 lbs)
BT40		7.7 (17.0 lbs)				
BT50		10.6 (23.4 lbs)				
HSK63A		220 (8.66")				7.4 (16.3 lbs)
HSK100A		9.5 (20.9 lbs)				
CAPTO C6		210 (8.27")				7.6 (16.8 lbs)
CAPTO C8		8.7 (19.2 lbs)				
HSK80F		220 (8.66")				8.4 (18.5 lbs)

*Total weight includes tapered positioning pin, taper body and modular attachment.

General Taper Reference

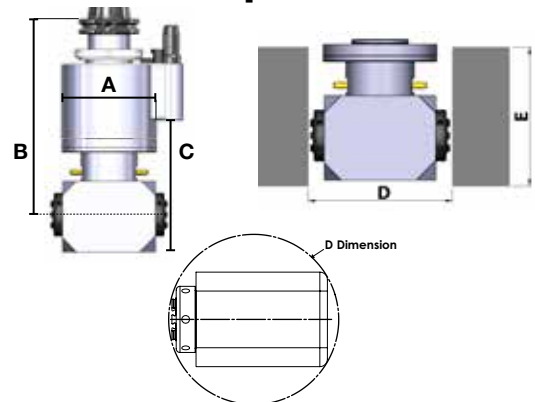

D dimension = Minimum bore diameter
E dimension = Maximum depth within bore diameter

Modular Attachment - NSK Adapter

Part #: MRAM-NSK-M17

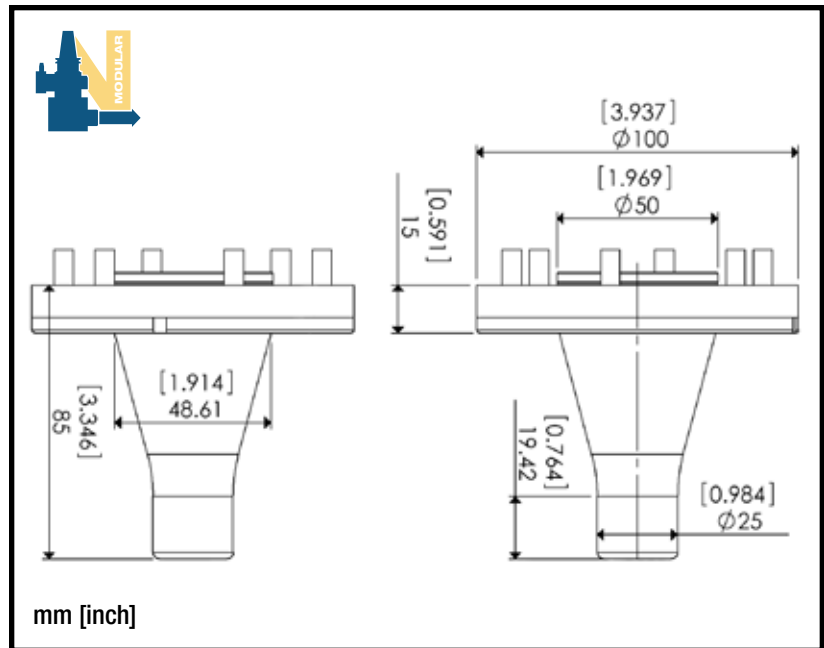

Features

- Input - 10,000 RPM
- Output - Max. 7,500 RPM
- 4:3 gear reduction ratio
- 1 Nm Torque Capable
- Miniature head for engraving and drilling applications in very small or tight areas
- Body can accept other NSK heads with M17 thread
- Additional NSK Attachments are available, please see page 32

General Taper Reference Dimensions

TAPER	A Dim (mm)	B Dim (mm)	C Dim (mm)	D Dim (mm)	E Dim (mm)	Total Weight (kg)*
CAT40	100 (3.94")	266.05 (10.47")	162.04 (6.38")	24 (0.95")	56.4 (2.22")	5.1 (11.2 lbs)
CAT50						7.5 (16.5 lbs)
BT40						5.6 (12.3 lbs)
BT50						8.5 (18.7 lbs)
HSK63A		276.05 (10.87")				5.3 (11.7 lbs)
HSK100A		7.4 (16.3 lbs)				
CAPTO C6		266.05 (10.47")				5.5 (12.1 lbs)
CAPTO C8		6.6 (14.5 lbs)				
HSK80F		276.05 (10.87")				6.3 (13.9 lbs)

*Total weight includes tapered positioning pin, taper body and modular attachment.
Dimensions shown include the MRAM-NSK-M17 attachment with the NSK IC-300 adapter.

General Taper Reference

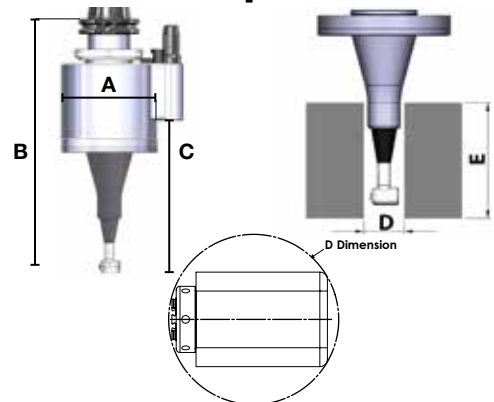

D dimension = Minimum bore diameter
E dimension = Maximum depth within bore diameter



Modular Attachment - MI32 Quick Change Adapter

Part #: MRAM-MI32

MRAM-MI32-IC
(Internal Coolant)

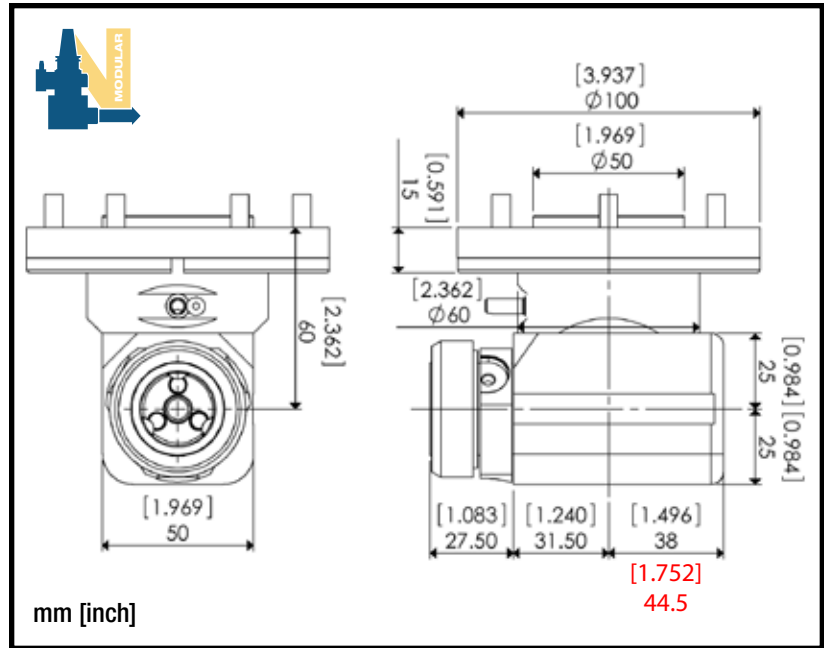

Larger dimension due to coolant-thru channel plate

Features

- 6000 RPM
- 10 Nm Torque Capable
- Utilizes patented MI modular system
- Interchangeable front adapters allow for cost effective flexibility
- Recessed spindle design keeps the body size compact even with front adapters
- Milling, Drilling, and Tapping can all be done with one head
- External Coolant standard
- Internal Coolant available
(PART #: MRAM-MI32-IC)

General Taper Reference Dimensions

TAPER	A Dim (mm)	B Dim (mm)	C Dim (mm)	D Dim (mm)	E Dim (mm)	Total Weight (kg)*			
CAT40	100 (3.94")	190 (7.48")	105 (4.13")	106 (4.17")	70 (2.76")	5.7 (12.6 lbs)			
CAT50						8.1 (17.9 lbs)			
BT40		200 (7.87")				6.2 (13.7 lbs)			
BT50						9.1 (20.1 lbs)			
HSK63A		200 (7.87")				105 (4.13")	106 (4.17")	70 (2.76")	5.9 (13.0 lbs)
HSK100A									8.0 (17.6 lbs)
CAPTO C6		190 (7.48")				105 (4.13")	106 (4.17")	70 (2.76")	6.1 (13.4 lbs)
CAPTO C8									7.2 (15.9 lbs)
HSK80F		200 (7.87")				105 (4.13")	106 (4.17")	70 (2.76")	6.9 (15.2 lbs)

*Total weight includes tapered positioning pin, taper body and modular attachment.
 D dimension does not include front attachment. *Internal Coolant version

General Taper Reference

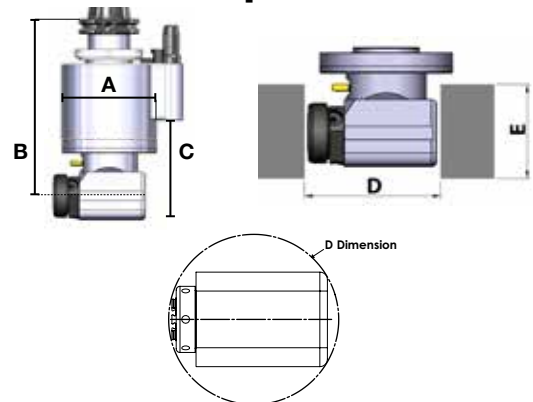

D dimension = Minimum bore diameter
 E dimension = Maximum depth within bore diameter

MI Adapter Wrench included: Part# 170734



MI Attachments are available, please see pages 30-31.



Modular Attachment - MI32 Long Quick Change Adapter

Part #: MRAM-MI32L

MRAM-MI32L-IC (Internal Coolant)

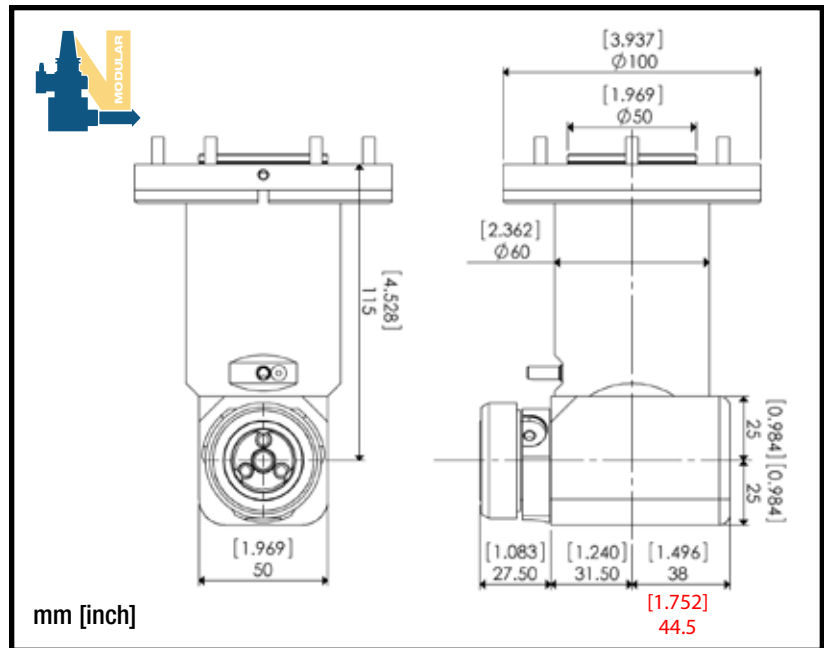

Larger dimension due to coolant-thru channel plate

Features

- 6000 RPM
- 10 Nm Torque Capable
- Utilizes patented MI modular system
- Interchangeable front adapters allow for cost effective flexibility
- Recessed spindle design keeps the body size compact even with front adapters
- Extended reach design is ideal for hard to reach applications around fixtures, or beyond machine table beds
- Milling, Drilling, and Tapping can all be done with one head
- External Coolant standard
- Internal Coolant available (PART #: MRAM-MI32L-IC)

General Taper Reference Dimensions

TAPER	A Dim (mm)	B Dim (mm)	C Dim (mm)	D Dim (mm)	E Dim (mm)	Total Weight (kg)	
CAT40	100 (3.94")	245 (9.65")	160 (6.30")	106 (4.17")	125 (4.92")	7.7 (17.0 lbs)	
CAT50						10.1 (22.3 lbs)	
BT40						8.2 (18.1 lbs)	
BT50						11.1 (24.5 lbs)	
HSK63A		255 (10.04")				116 (4.57")*	7.9 (17.4 lbs)
HSK100A							10.0 (22.0 lbs)
CAPTO C6		245 (9.65")				116 (4.57")*	8.1 (17.9 lbs)
CAPTO C8							9.2 (20.3 lbs)
HSK80F							255 (10.04")

*Total weight includes tapered positioning pin, taper body and modular attachment.
 D dimension does not include front attachment. *Internal Coolant version

General Taper Reference

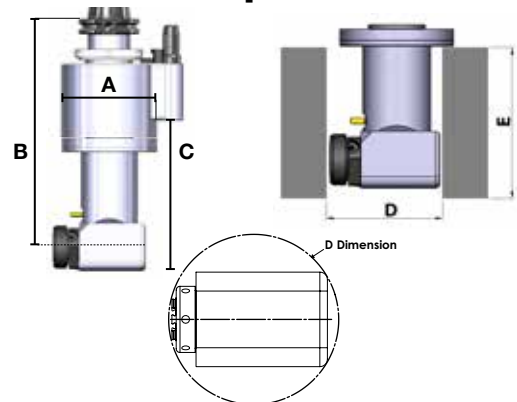

D dimension = Minimum bore diameter
 E dimension = Maximum depth within bore diameter

MI Adapter Wrench included: Part# 170734



MI Attachments are available, please see pages 30-31.



Modular Attachment - MI40 Quick Change Adapter

Part #: MRAM-MI40
MRAM-MI40-IC
(Internal Coolant)

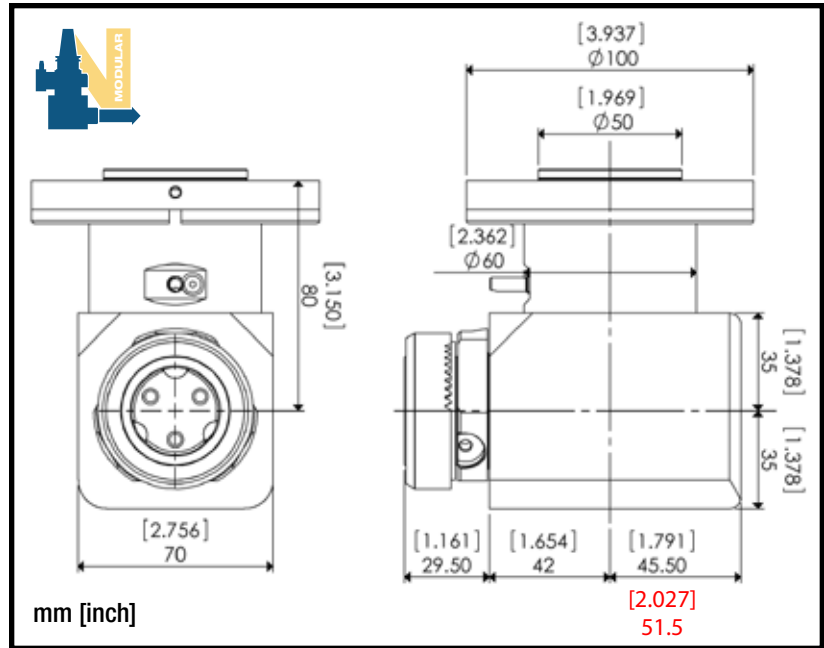

Larger dimension due to coolant-thru channel plate

Features

- 5000 RPM
- 25 Nm Torque Capable
- Utilizes patented MI modular system
- Interchangeable front adapters allow for cost effective flexibility
- Recessed spindle design keeps the body size compact even with front adapters
- Milling, Drilling, and Tapping can all be done with one head
- External Coolant standard
- Internal Coolant available
(PART #: MRAM-MI40-IC)

General Taper Reference Dimensions

TAPER	A Dim (mm)	B Dim (mm)	C Dim (mm)	D Dim (mm)	E Dim (mm)	Total Weight (kg)
CAT40	100 (3.94")	210 (8.27")	135 (5.31")	131 (5.16")	99 (3.90")	7.0 (15.4 lbs)
CAT50						9.4 (20.7 lbs)
BT40		7.5 (16.5 lbs)				
BT50		10.4 (22.9 lbs)				
HSK63A		220 (8.66")				7.2 (15.9 lbs)
HSK100A		9.3 (20.5 lbs)				
CAPTO C6		210 (8.27")				7.4 (16.3 lbs)
CAPTO C8		8.5 (18.7 lbs)				
HSK80F		220 (8.66")				8.2 (18.1 lbs)

*Total weight includes tapered positioning pin, taper body and modular attachment.
D dimension does not include front attachment. *Internal Coolant version

General Taper Reference

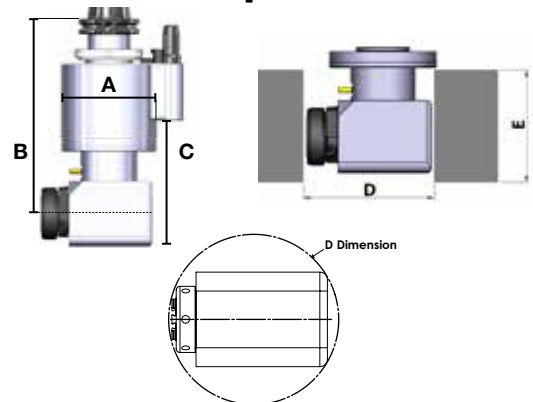

D dimension = Minimum bore diameter
E dimension = Maximum depth within bore diameter

MI Adapter Wrench included: Part# 170734



MI Attachments are available, please see pages 30-31.



Modular Attachment - MI40 Long Quick Change Adapter

Part #: MRAM-MI40L

MRAM-MI40L-IC (Internal Coolant)

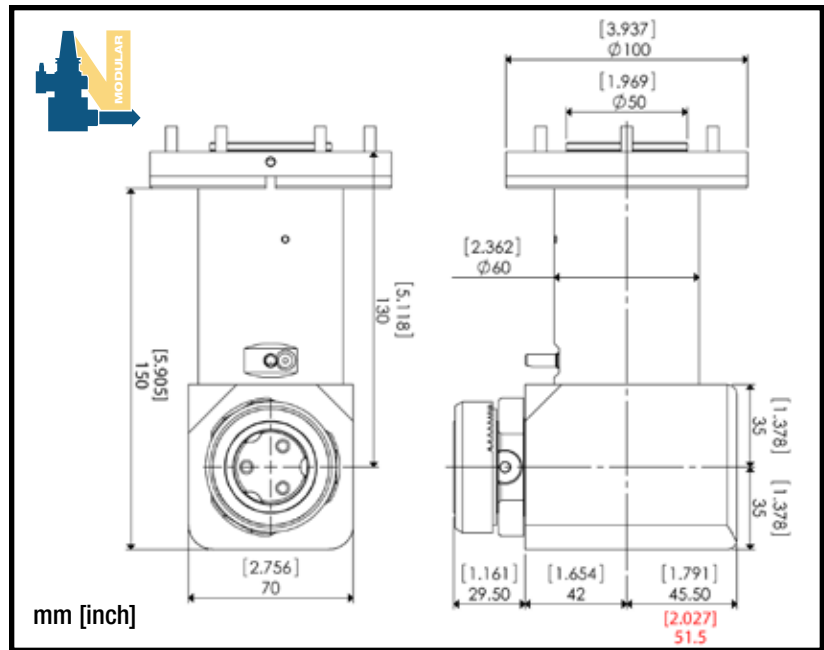

Larger dimension due to coolant-thru channel plate

Features

- 5000 RPM
- 25 Nm Torque Capable
- Utilizes patented MI modular system
- Interchangeable front adapters allow for cost effective flexibility
- Recessed spindle design keeps the body size compact even with front adapters
- Extended reach design is ideal for hard to reach applications around fixtures, or beyond machine table beds
- Milling, Drilling, and Tapping can all be done with one head
- External Coolant standard
- Internal Coolant available (PART #: MRAM-MI40L-IC)

General Taper Reference Dimensions

TAPER	A Dim (mm)	B Dim (mm)	C Dim (mm)	D Dim (mm)	E Dim (mm)	Total Weight (kg)
CAT40	100 (3.94")	260 (10.24")	185 (7.28")	131 (5.16")	149 (5.87")	7.6 (16.8 lbs)
CAT50						10 (22.0 lbs)
BT40		8.1 (17.9 lbs)				
BT50		11 (24.2 lbs)				
HSK63A		270 (10.63")				9.9 (21.8 lbs)
HSK100A		142 (5.59")*				8.0 (17.6 lbs)
CAPTO C6		260 (10.24")				9.1 (20.1 lbs)
CAPTO C8		270 (10.63")				8.8 (19.4 lbs)
HSK80F						

*Total weight includes tapered positioning pin, taper body and modular attachment.
D dimension does not include front attachment. *Internal Coolant version

General Taper Reference

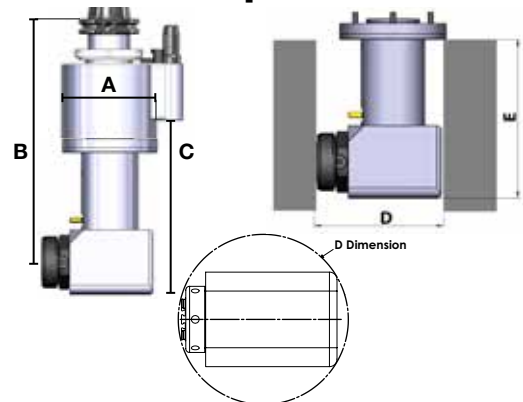

D dimension = Minimum bore diameter
E dimension = Maximum depth within bore diameter

MI Adapter Wrench included: Part# 170734



MI Attachments are available, please see pages 30-31.



Mimatic® MI Attachments

Collet Chuck DIN 6499 - Type ER

Short type, clamping nut inside

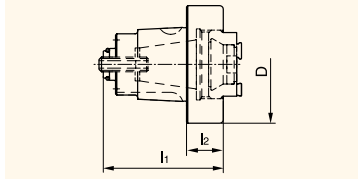

Part Number	Size	Collet	I1	I2	D
MI32-ER11I	MI32	ER11	1.634"	0.591"	1.654"
MI32-ER16I	MI32	ER16	1.634"	0.591"	1.654"
MI40-ER16I	MI40	ER16	1.772"	0.433"	1.890"
MI40-ER20I	MI40	ER20	1.929"	0.591"	1.890"
MI40-ER25I	MI40	ER25	2.165"	0.827"	1.890"

Combination Shell End Mill Arbor

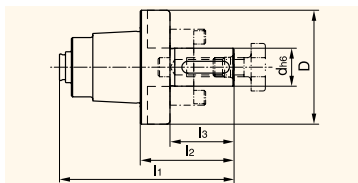

Part Number	Size	I1	I2	I3	d(h6)	D
MI32-SM16	MI32	2.598"	1.555"	1.063"	16mm (.630")	1.654"
MI40-SM16	MI40	2.894"	1.555"	0.984"	16mm (.630")	1.890"

Shrink Fit Chuck

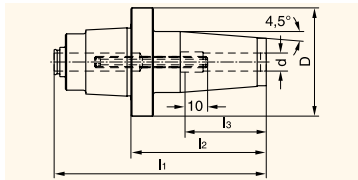

Part Number	Size	I1	I2	I3	d(h6)	D
MI40-SF8	MI40	3.701"	2.362"	1.417"	8mm (.315")	1.890"
MI40-SF10	MI40	3.701"	2.362"	1.654"	10mm (.394")	1.890"
MI40-SF12	MI40	3.898"	2.559"	1.850"	12mm (.472")	1.890"
MI40-SF16	MI40	4.094"	2.756"	1.969"	16mm (.630")	1.890"

Tool Presetting Unit

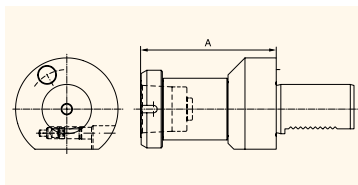

Part Number	Size	VDI	A
MI40-PRESET-VDI40	MI40	2.520"	108mm

Long type, clamping nut outside

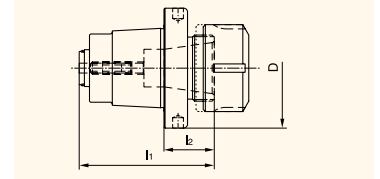

Part Number	Size	Collet	I1	I2	D
MI32-ER11	MI32	ER11	2.461"	1.417"	1.654"
MI32-ER16	MI32	ER16	1.988"	0.945"	1.654"
MI40-ER16	MI40	ER16	2.283"	0.945"	1.890"
MI40-ER20	MI40	ER20	2.520"	1.181"	1.890"

Softsynchro Chuck (Licence Emuge)

with internal coolant
with push and pull length
compensation 0.5mm

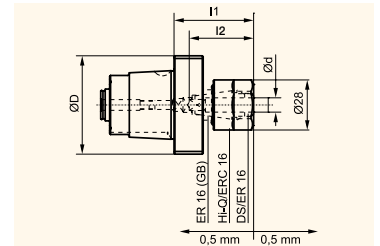

Part Number	Size	Collet	Thread	I1	I2	D
MI40-ER-GB16	MI40	ER-GB16	M4-M12	1.870"	.177-.394"	1.772"

Blank

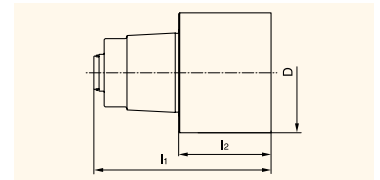

Part Number	Size	I1	I2	D
MI32-BLANK	MI32	3.012"	1.969"	1.654"
MI40-BLANK	MI40	3.701"	2.362"	1.890"

Hydraulic Chuck

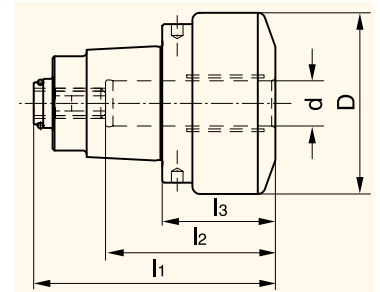

Part Number	Size	I1	I2	I3	d(h6)	D
MI40-HC12	MI40	2.520"	1.772"	1.181"	12mm (.472")	1.890"

Mimatic® MI Attachments

Weldon Toolholder DIN 1835 B

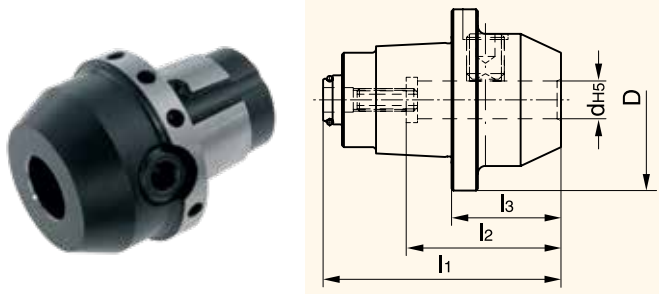

Whistle Notch Toolholder DIN 1835 E

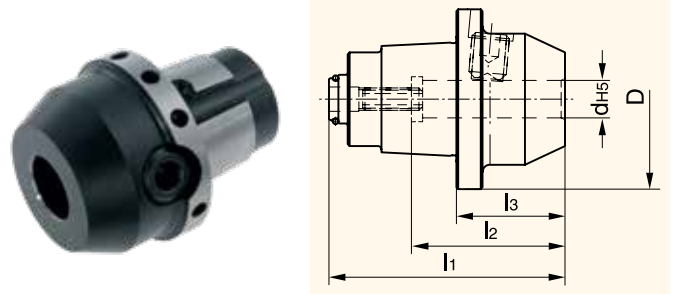

Part Number	Size	l1	l2	l3	d(h5)	D
MI32-EM6	MI32	2.067"	1.457"	1.024"	6	1.654"
MI32-EM8	MI32	2.067"	1.457"	1.024"	8	1.654"
MI32-EM10	MI32	2.185"	1.614"	1.142"	10	1.654"
MI32-EM12	MI32	2.264"	1.811"	1.220"	12	1.654"
MI32-EM1/4	MI32	2.067"	1.457"	1.024"	1/4"	1.654"
MI32-EM3/8	MI32	2.185"	1.614"	1.142"	3/8"	1.654"
MI32-EM1/2	MI32	2.264"	1.811"	1.220"	1/2"	1.654"
MI40-EM6	MI40	2.362"	1.457"	1.024"	6	1.890"
MI40-EM8	MI40	2.362"	1.457"	1.024"	8	1.890"
MI40-EM10	MI40	2.480"	1.614"	1.142"	10	1.890"
MI40-EM12	MI40	2.559"	1.811"	1.220"	12	1.890"
MI40-EM14	MI40	2.559"	1.811"	1.220"	14	1.890"
MI40-EM16	MI40	2.677"	1.929"	1.339"	16	1.890"
MI40-EM1/4	MI40	2.362"	1.457"	1.024"	1/4"	1.890"
MI40-EM3/8	MI40	2.480"	1.614"	1.142"	3/8"	1.890"
MI40-EM1/2	MI40	2.559"	1.811"	1.220"	1/2"	1.890"
MI40-EM5/8	MI40	2.677"	1.929"	1.339"	5/8"	1.890"

Part Number	Size	l1	l2	l3	d(h5)	D
MI32-EM6A	MI32	2.067"	1.417"	1.024"	6	1.654"
MI32-EM8A	MI32	2.067"	1.417"	1.024"	8	1.654"
MI32-EM10A	MI32	2.185"	1.575"	1.142"	10	1.654"
MI32-EM12A	MI32	2.264"	1.772"	1.220"	12	1.654"
MI32-EM1/4A	MI32	2.067"	1.417"	1.024"	1/4"	1.654"
MI32-EM3/8A	MI32	2.185"	1.575"	1.142"	3/8"	1.654"
MI32-EM1/2A	MI32	2.264"	1.772"	1.220"	1/2"	1.654"
MI40-EM6A	MI40	2.362"	1.417"	1.024"	6	1.890"
MI40-EM8A	MI40	2.362"	1.417"	1.024"	8	1.890"
MI40-EM10A	MI40	2.480"	1.575"	1.142"	10	1.890"
MI40-EM12A	MI40	2.559"	1.772"	1.220"	12	1.890"
MI40-EM14A	MI40	2.559"	1.772"	1.220"	14	1.890"
MI40-EM16A	MI40	2.677"	1.890"	1.339"	16	1.890"
MI40-EM1/4A	MI40	2.362"	1.417"	1.024"	1/4"	1.890"
MI40-EM3/8A	MI40	2.480"	1.575"	1.142"	3/8"	1.890"
MI40-EM1/2A	MI40	2.559"	1.772"	1.220"	1/2"	1.890"
MI40-EM5/8A	MI40	2.677"	1.890"	1.339"	5/8"	1.890"

SYNAX® Tapping Quick Change Holder

without internal coolant,
with synchronization and length
compensation

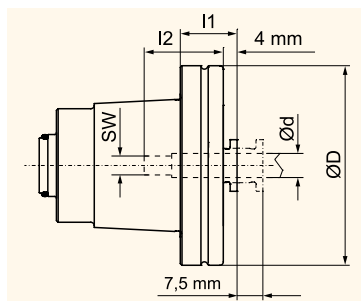

with internal coolant (70 bar),
only synchronization

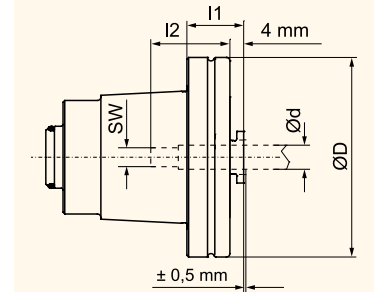

Part Number	Size	l1	l2	d	D	SW
MI40-TAP3.5	MI40	0.669"	0.984"	3.5mm (.138")	1.890"	0.106"
MI40-TAP4.5	MI40	0.669"	0.984"	4.5mm (.177")	1.890"	0.134"
MI40-TAP6	MI40	0.669"	1.063"	6mm (.236")	1.890"	0.193"
MI40-TAP8	MI40	0.669"	1.063"	8mm (.315")	1.890"	0.244"
MI40-TAP9	MI40	1.496"	1.102"	9mm (.354")	1.890"	0.276"
MI40-TAP10	MI40	1.496"	1.142"	10mm (.394")	1.890"	0.315"
MI40-TAP12	MI40	1.496"	1.181"	12mm (.472")	1.890"	0.354"

Part Number	Size	l1	l2	d	D	SW
MI40-TAP6C	MI40	0.669"	1.063"	6mm (.236")	1.890"	0.193"
MI40-TAP8C	MI40	0.669"	1.063"	8mm (.315")	1.890"	0.244"
MI40-TAP9C	MI40	1.496"	1.102"	9mm (.354")	1.890"	0.276"
MI40-TAP10C	MI40	1.496"	1.142"	10mm (.394")	1.890"	0.315"
MI40-TAP12C	MI40	1.496"	1.181"	12mm (.472")	1.890"	0.354"

NSK Attachments

NSK IC-300 Attachment



INPUT RPM: 10,000
OUTPUT RPM: 7,500
MAX COLLET RANGE - 1/8"
Includes 1/8" collet with purchase

NSK KC-300 Attachment

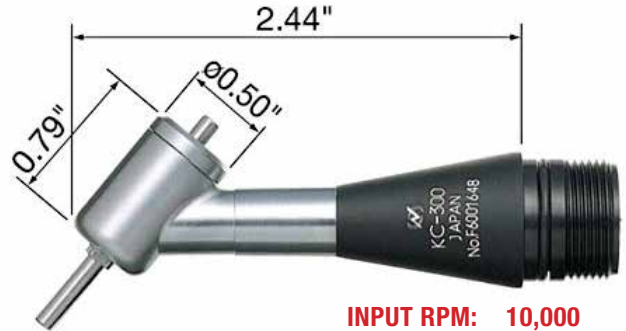

INPUT RPM: 10,000
OUTPUT RPM: 7,500
MAX COLLET RANGE - 1/8"

NSK MFC-300M Attachment



INPUT RPM: 10,000
OUTPUT RPM: 9,090
MAX COLLET RANGE - 1/16"

NSK MFC-300S Attachment

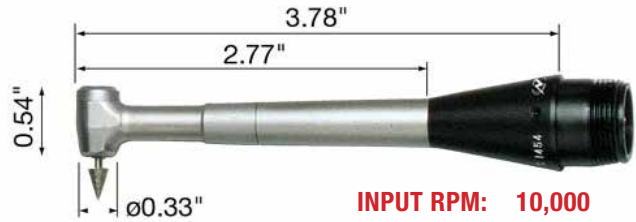

INPUT RPM: 10,000
OUTPUT RPM: 10,000
MAX COLLET RANGE - 1/16"

NSK RA-200 Attachment

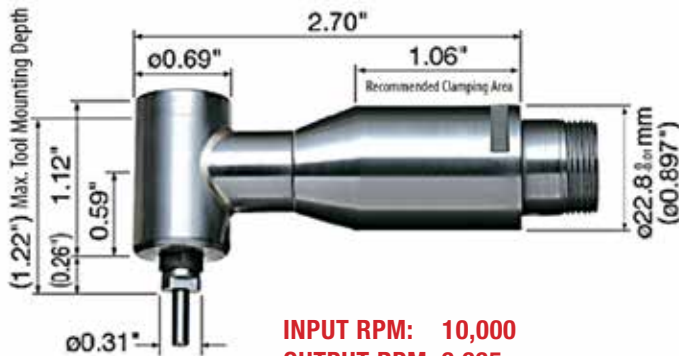

INPUT RPM: 10,000
OUTPUT RPM: 6,665
MAX COLLET RANGE - 1/8"

Angle Head Positioning Pins and Blocks

Positioning Pin

- Securely holds the angle head in position
- Creates greater alignment accuracy for machining operations
- Provides support during heavy drilling
- Channels coolant through body for external/internal coolant

65/80mm pitch type - For CAT/BT40, HSK63A, and C6

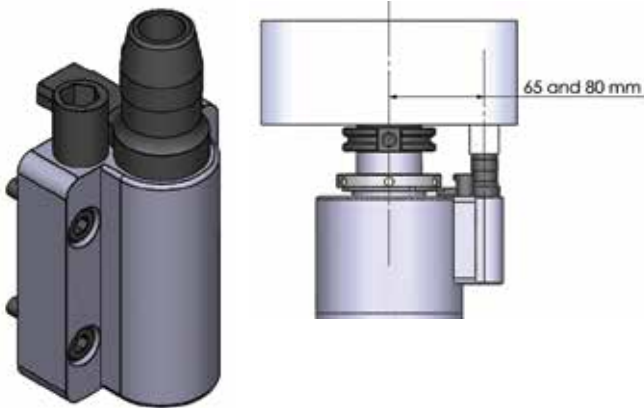

110mm pitch - For CAT/BT50, HSK 80F, HSK100A, and C8

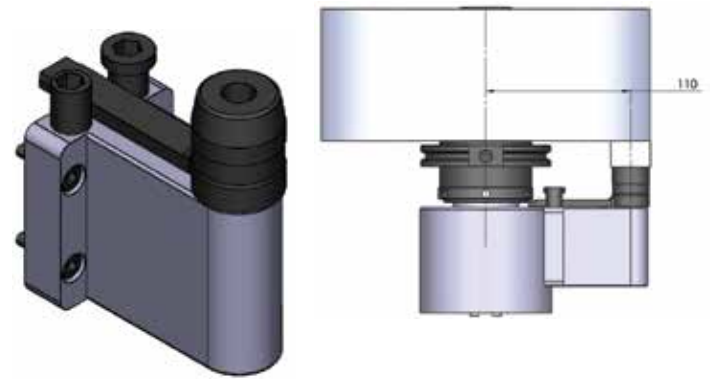

Positioning Block - Blank

A positioning block may require slight modifications to accommodate your particular machine. *Please contact Lyndex-Nikken for additional support to help design the Positioning Block for your machine.*

Part #: PB-RAN40-BLANK (40 Taper)

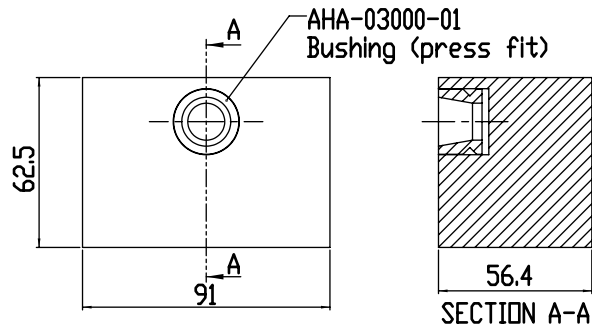

Part #: PB-RAN50-BLANK (50 Taper)

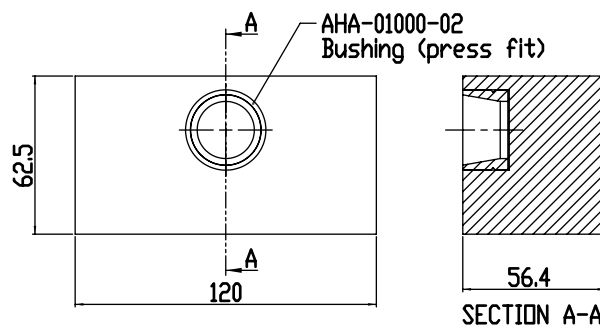

ER Collet



ER Standard Type Collet

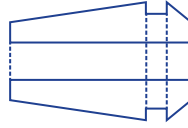

Flexibility and Durability:

We offer the ultimate trifecta: wide clamping range, ultra precision, and super high pressure. Our 1300 psi capable collets have a wide 0.031" collapse range and the ability to maintain less than 0.0001" run out at the collet nose.

ER Counter-Bored Type Collet

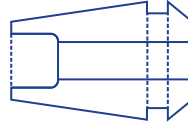

Ultra Precision for Micro Cutters:

Our high precision "On Size" collets have 25% longer collet bore lengths than competitors, resulting in stronger gripping power at higher RPMs. The high-pressure coolant collet's special design reduces cutter vibration due to high pressure.

STANDARD (INCH)

SIZE	ER11	ER16	ER20	ER25
1/32"	E11-002	E16-002	-	-
3/64"	E11-003	-	-	-
1/16"	E11-004	E16-004	E20-004	E25-004
5/64"	E11-005	-	-	-
3/32"	E11-006	E16-006	E20-006	E25-006
7/64"	E11-007	-	-	-
1/8"	E11-008	E16-008	E20-008	E25-008
9/64"	E11-009	-	-	-
5/32"	E11-010	E16-010	E20-010	E25-010
11/64"	E11-011	-	-	-
3/16"	E11-012	E16-012	E20-012	E25-012
13/64"	E11-013	-	-	-
7/32"	E11-014	E16-014	E20-014	E25-014
15/64"	E11-015	-	-	-
1/4"	E11-016	E16-016	E20-016	E25-016
17/64"	E11-017	-	-	-
9/32"	-	E16-018	E20-018	E25-018
5/16"	-	E16-020	E20-020	E25-020
11/32"	-	E16-022	E20-022	E25-022
3/8"	-	E16-024	E20-024	E25-024
13/32"	-	E16-026	E20-026	E25-026
7/16"	-	-	E20-028	E25-028
15/32"	-	-	E20-030	E25-030
1/2"	-	-	E20-032	E25-032
17/32"	-	-	-	E25-034
9/16"	-	-	-	E25-036
19/32"	-	-	-	E25-038
5/8"	-	-	-	E25-040

STANDARD (METRIC)

SIZE	ER11	ER16	ER20	ER25
1.0mm	E11-039	E16-039	-	-
1.5mm	E11-059	E16-059	-	-
2.0mm	E11-078	E16-078	E20-078	E25-078
2.5mm	E11-098	E16-098	-	-
3.0mm	E11-118	E16-118	E20-118	E25-118
3.5mm	E11-137	E16-137	E20-137	E25-137
4.0mm	E11-157	E16-157	E20-157	E25-157
4.5mm	E11-177	E16-177	-	-
5.0mm	E11-196	E16-196	E20-196	E25-196
5.5mm	E11-216	E16-216	-	-
6.0mm	E11-236	E16-236	E20-236	E25-236
6.5mm	E11-255	E16-255	-	-
7.0mm	E11-275	E16-275	E20-275	E25-275
7.5mm	-	E16-295	-	-
8.0mm	-	E16-314	E20-314	E25-314
8.5mm	-	E16-334	-	-
9.0mm	-	E16-354	E20-354	E25-354
9.5mm	-	E16-374	-	-
10.0mm	-	E16-393	E20-393	E25-393
11.0mm	-	-	E20-433	E25-433
11.5mm	-	-	E20-452	E25-452
12.0mm	-	-	E20-472	E25-472
13.0mm	-	-	E20-511	E25-511
14.0mm	-	-	-	E25-551
15.0mm	-	-	-	E25-590
16.0mm	-	-	-	E25-629

ER Collet Dimensional Data

Style	D	D1	L	Collet Range	Coolant Collet Size Range	Nut Tightening Torque	
						Lbs-Ft.	Nm
ER11	0.460"	0.307"	0.709"	0.019 - 0.275"	0.157 - 0.275"	11	15
ER16	0.677"	0.445"	1.063"	0.019 - 0.393"	0.157 - 0.393"	40	54
ER20	0.835"	0.571"	1.220"	0.039 - 0.511"	0.196 - 0.511"	45	61
ER25	1.031"	0.728"	1.378"	0.039 - 0.629"	0.236 - 0.629"	70	95

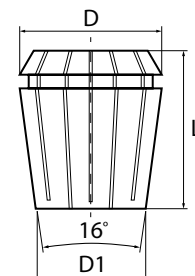

ER Coolant Collet



COOLANT (INCH)

SIZE	ER11	ER16	ER20	ER25
3/32"	-	E16-006(C)	-	-
7/64"	-	E16-007(C)	-	-
1/8"	-	E16-008(C)	-	-
9/64"	-	E16-009(C)	-	-
5/32"	-	E16-010(C)	E20-010(C)	-
11/64"	-	E16-011(C)	E20-011(C)	-
3/16"	E11-012(C)	E16-012(C)	E20-012(C)	-
13/64"	E11-013(C)	E16-013(C)	E20-013(C)	-
7/32"	E11-014(C)	E16-014(C)	E20-014(C)	E25-014(C)
15/64"	E11-015(C)	E16-015(C)	E20-015(C)	E25-015(C)
1/4"	E11-016(C)	E16-016(C)	E20-016(C)	E25-016(C)
17/64"	E11-017(C)	E16-017(C)	E20-017(C)	E25-017(C)
9/32"	-	E16-018(C)	E20-018(C)	E25-018(C)
19/64"	-	E16-019(C)	E20-019(C)	E25-019(C)
5/16"	-	E16-020(C)	E20-020(C)	E25-020(C)
21/64"	-	E16-021(C)	E20-021(C)	E25-021(C)
11/32"	-	E16-022(C)	E20-022(C)	E25-022(C)
23/64"	-	E16-023(C)	E20-023(C)	E25-023(C)
3/8"	-	E16-024(C)	E20-024(C)	E25-024(C)
25/64"	-	E16-025(C)	E20-025(C)	E25-025(C)
13/32"	-	E16-026(C)	E20-026(C)	E25-026(C)
27/64"	-	-	E20-027(C)	E25-027(C)
7/16"	-	-	E20-028(C)	E25-028(C)
29/64"	-	-	E20-029(C)	E25-029(C)
15/32"	-	-	E20-030(C)	E25-030(C)
31/64"	-	-	E20-031(C)	E25-031(C)
1/2"	-	-	E20-032(C)	E25-032(C)
33/64"	-	-	-	E25-033(C)
17/32"	-	-	-	E25-034(C)
35/64"	-	-	-	E25-035(C)
9/16"	-	-	-	E25-036(C)
37/64"	-	-	-	E25-037(C)
19/32"	-	-	-	E25-038(C)
39/64"	-	-	-	E25-039(C)
5/8"	-	-	-	E25-040(C)

COOLANT (METRIC)

SIZE	ER11	ER16	ER20	ER25
4.0mm	E11-157(C)	E16-157(C)	-	-
4.5mm	E11-177(C)	E16-177(C)	-	-
5.0mm	E11-196(C)	E16-196(C)	E20-196(C)	-
5.5mm	E11-216(C)	E16-216(C)	E20-216(C)	-
6.0mm	E11-236(C)	E16-236(C)	E20-236(C)	E25-236(C)
6.5mm	E11-255(C)	E16-255(C)	E20-255(C)	E25-255(C)
7.0mm	E11-275(C)	E16-275(C)	E20-275(C)	E25-275(C)
7.5mm	-	E16-295(C)	E20-295(C)	E25-295(C)
8.0mm	-	E16-314(C)	E20-314(C)	E25-314(C)
8.5mm	-	E16-334(C)	E20-334(C)	E25-334(C)
9.0mm	-	E16-354(C)	E20-354(C)	E25-354(C)
9.5mm	-	E16-374(C)	E20-374(C)	E25-374(C)
10.0mm	-	E16-393(C)	E20-393(C)	E25-393(C)
10.5mm	-	-	E20-413(C)	E25-413(C)
11.0mm	-	-	E20-433(C)	E25-433(C)
11.5mm	-	-	E20-452(C)	E25-452(C)
12.0mm	-	-	E20-472(C)	E25-472(C)
12.5mm	-	-	E20-492(C)	E25-492(C)
13.0mm	-	-	E20-511(C)	E25-511(C)
13.5mm	-	-	-	E25-531(C)
14.0mm	-	-	-	E25-551(C)
14.5mm	-	-	-	E25-570(C)
15.0mm	-	-	-	E25-590(C)
15.5mm	-	-	-	E25-610(C)
16.0mm	-	-	-	E25-629(C)

FREQUENTLY ASKED QUESTIONS

- **How do I assemble the unit?**

Each Modular Attachment has a locating pilot and a drive tang to help align the unit. 6 cap screws secure the Modular Attachment to the Taper Attachment. It's that simple.

- **Does the unit come with a positioning block?**

Position blocks are not included. Our technical department can help select a positioning block for your machine.

- **Can I make my own positioning block?**

Yes and we can assist you if needed. A positioning block may require slight modifications to accommodate your particular machine. Please contact Lyndex-Nikken for additional support to help design the Positioning Block for your machine.

- **How do I determine where to mount the positioning block?**

The positioning block must be located where the Automatic Tool Change arm won't interfere with it and where there are mounting hole locations.

- **Can I tool change the angle head?**

Yes, however check the weight and clearance restrictions on your machine.

- **How fast can I run the angle head?**

We have a posted maximum RPM in the catalog. Feed rates depend on the type of application and tooling. Please call our technical department to review.

- **Can I tap with this unit?**

Yes, but you will need an axial compensating tap collet.

- **How do I align or indicate the angle head?**

The most accurate way is to dial in a chucked pin gage. The side of the attachment can be used to get close, but fine adjustments should be made with a pin afterwards.

- **How do I know how to choose the best angle head for my application?**

Please fill out our angle head questionnaire and we will review your application. We will then help select the best product for you.

- **Will this angle head fit into my work piece?**

We can design a full layout for you. All we need is a part drawing or some measurements from you. We can provide a solid model or a drawing to show the clearances needed.

- **What type of maintenance procedures do I need to follow?**

Besides keeping the unit clean, there is no need to take the unit apart, or to re-grease. If you have unusual sounds or performance issues please contact our technical department for review. We offer a full evaluation/repair program for your unit.

Complete engineering support from start to finish!



Selecting the best Angle Head

- Fill out our Angle Head Questionnaire
- Provide dimensional and material information about your part via 3D model and/or CAD drawing
- Additional information about the machine, current processes and cycle times are gathered

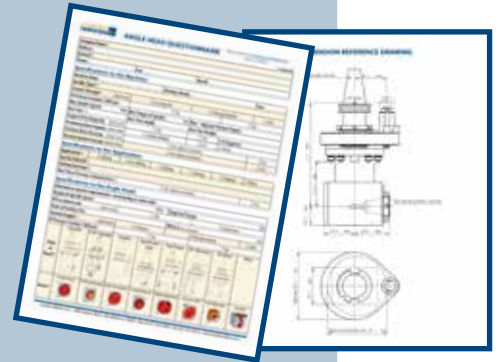

Verification of Clearance and Application

- 3D models of angle heads are used to verify internal motion in space critical locations
- Applications are qualified by determining torque calculations of the machining operation, and is verified again that the Angle Head can sustain the desired process

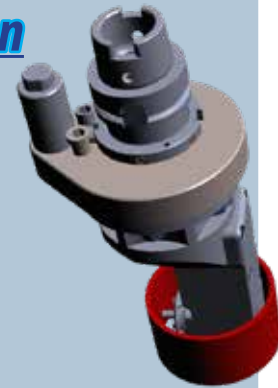

Automatic Tool Change & Weight Confirmation

- ATC and weight clearances are confirmed
- 3D printed Angle Heads and positioning blocks are available to ensure 100% dimensional accuracy and guarantees clearance while reducing cost and risk to the customer

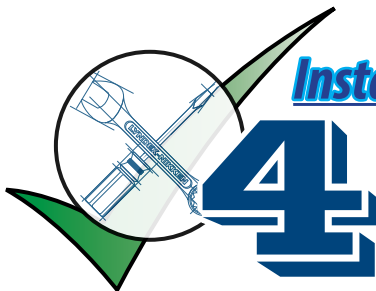

Installation & Additional Support

- Additional support for positioning block design and integration of the unit are also available
- Positioning blocks are made to specifications, ensuring that the angle head is positioned and locked into place during final installation



SPECIAL CUSTOM POSITIONING BLOCK

**Why risk your investment?
We have you covered from design to installation!**



Lyndex-Nikken website:

Be sure to check out our website
www.lyndexnikken.com

to find out more about our products,
services and all we have to offer!

This customer-friendly site provides a
complete overview of our product line,
and features technical data, videos,
CAD drawings, catalogs and more.



www.lyndexnikken.com

**1468 Armour Boulevard
Mundelein, IL 60060**

E-mail: sales@lyndexnikken.com

Phone: (847) 367-4800

Fax: (847) 367-4815

CAT2019-MRAM MAR. 2021



**FLEXIBILITY &
PERFORMANCE**