

ULTRA-PRECISION HIGH-SPEED MILLING SPINDLE

HES Spindles

Electric System

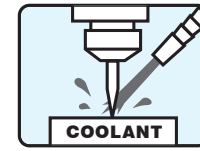

HES Series can be used in conjunction with water or oil based coolants.

Product Highlights

- Brushless DC motor with cooling air and purge air allow long, continuous operation without heat buildup
- Ceramic Bearings allow for extreme high-precision cutting with maximized life expectancy
- Smooth Rotation and Low Vibration yields better surface finish
- One-Piece motor and spindle construction
- Emergency Connector standard on all HES Spindles

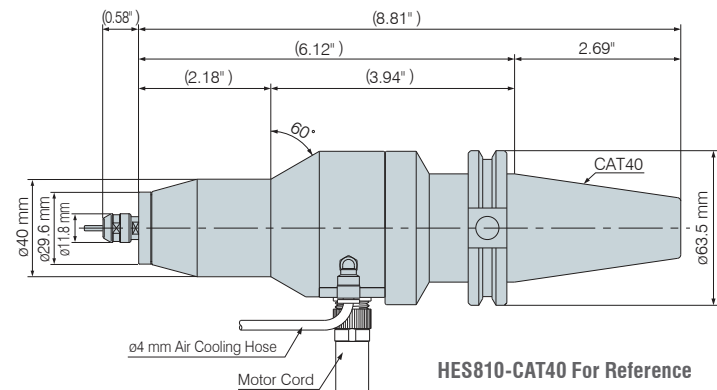

Quick and Easy Installation - can be done in 15 minutes or less

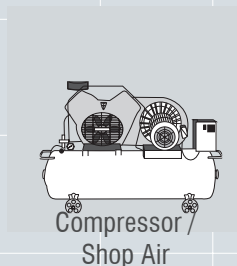

Air Line Kit AL-C1204
(Refer to Catalog 4p15 for Details)



Controller NE211
(Refer to Catalog 4p14 for Details)



HES510/
HES810

The HES Series motors and spindles require dry, clean, regulated air.

Available Connections

- BT, NT, CAT, IT, ST32, R8 and HSK A tapers are available.



Factory Machine Tool - Max. 10,000rpm



HES510 Spindle - Max. 50,000rpm

HES810 Spindle - Max. 80,000rpm

ULTRA-PRECISION HIGH-SPEED MILLING SPINDLE

HES Spindles

Electric System

- HES spindles allow you to modify your existing equipment for high speed micro machining
- HES Spindles give conventional milling machines and machining centers the capability to do higher-speed machining, small diameter drilling, small diameter milling, and engraving

HES510

5,000-50,000 rpm

Spindle Prices Starting at \$2,980

Max. Collet Size **6.35 mm**

Max. Output Power **340W**

Spindle Accuracy **less than 1 μ m**

Torque & Output Power

Characteristic of HES510

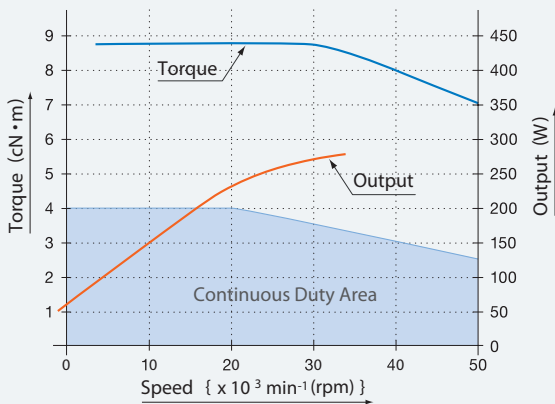

Purchasing Example - HES 510 (Based on CAT40 Spindle Pricing)

Description	Price
Spindle with CAT40 (with standard 1/8" collet)	3,142.00
Controller	2,025.00
13ft Motor Cord	400.00
Air Line Kit	350.00

Total 5,917.00

HES810

20,000-80,000 rpm

Spindle Prices Starting at \$5,408

Max. Collet Size **4.0 mm**

Max. Output Power **350W**

Spindle Accuracy **less than 1 μ m**

Torque & Output Power

Characteristic of HES810

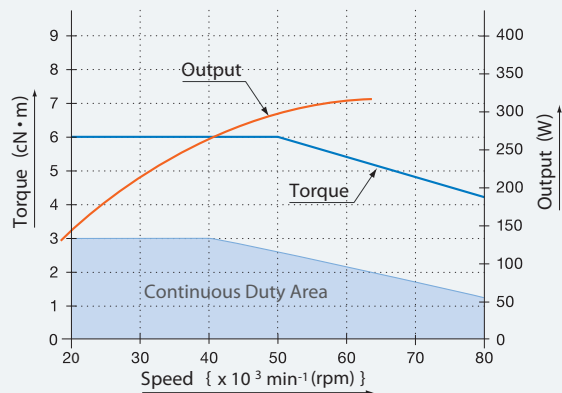

Purchasing Example - HES 810 (Based on CAT40 Spindle Pricing)

Description	Price
Spindle with CAT40 (with standard 1/8" collet)	5,559.00
Controller	2,025.00
13ft Motor Cord	400.00
Air Line Kit	350.00

Total 8,334.00