

# BMT65

by **PARLEC**

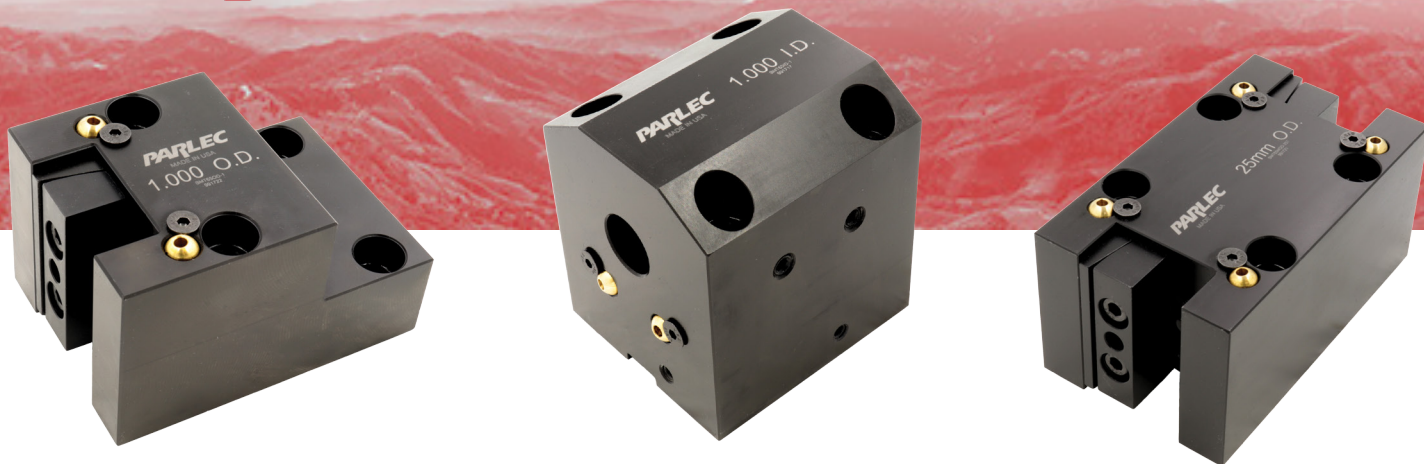

PARLEC has been producing BMT65 tool holders under private-label agreements for some of the largest machine OEMs for years. Now, we're offering our OEM-quality BMT65 tool holders to ALL our customers!

## Parlec BMT 65 Advantages:

### OEM Quality

Having been a provider of BMT65 tool holding to some of the largest machine OEMs, we understand a thing or two about how to make world-class BMT65 tool holders for some of the most demanding customers.

Quality down to the finest detail  
- that's Parlec!

### Fit and Finish

Parlec BMT65 tool holders match popular machine OEM specifications to ensure seamless integration into your production.

Our BMT65 tool holders have a 70mm x 73mm bolt hole mounting pattern and feature three drive keys on the bottom to ensure perfect alignment without needing to make adjustments.

### Ductile Iron

While other providers use steel for their BMT holders, Parlec uses ductile iron as required by some of the largest machine OEMs. Why ductile iron? Ductile iron has 6.6x better vibration damping properties than steel for superior machining results.

Plus, the higher graphite content of ductile iron has superior anti-abrasion characteristics than steel to provide long life.



**ALWAYS 100% MADE-IN-USA MEANS WE HAVE THE BMT65 TOOLING YOU NEED, IN STOCK AND READY TO GO INTO PRODUCTION TODAY!**

Part #: BMT65ID-1-PARLEC

\$ 280.00

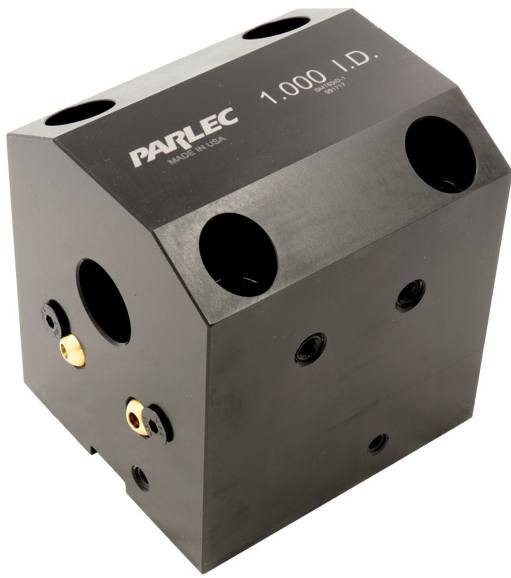

- OEM-level quality ensures optimal performance
- Made from ductile iron for superior vibration damping and improved cutting performance
- 100% made-in-USA
- For 1" diameter tooling

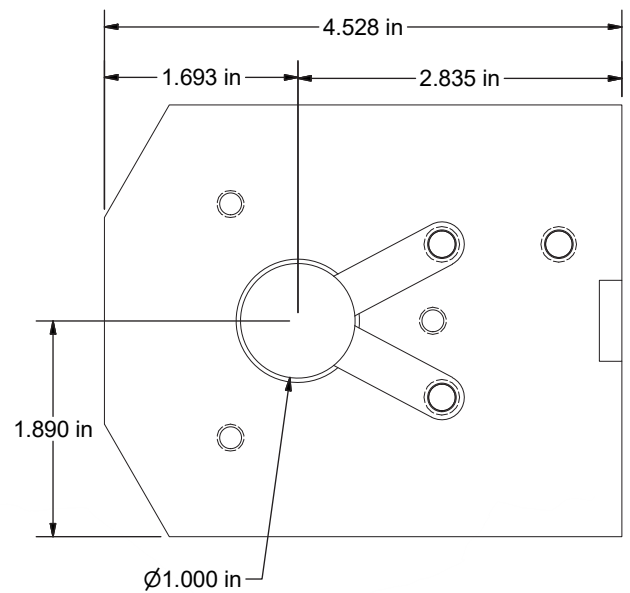
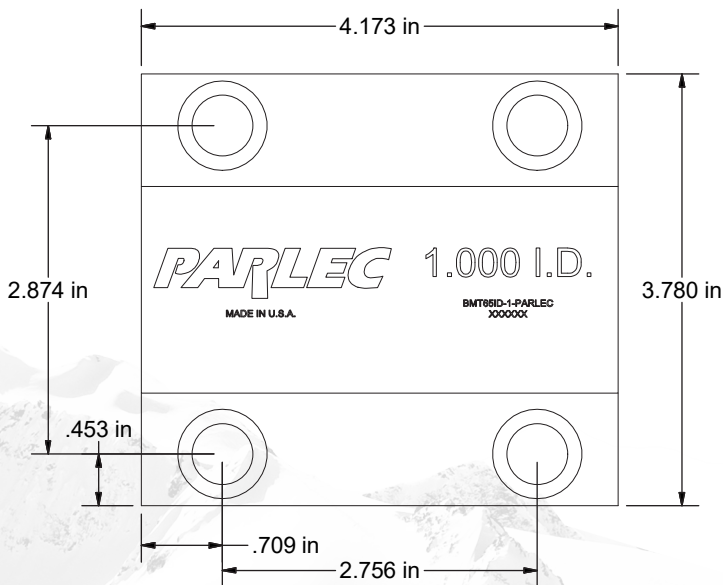

Part #: BMT65MID-25-PARLEC

\$ 280.00

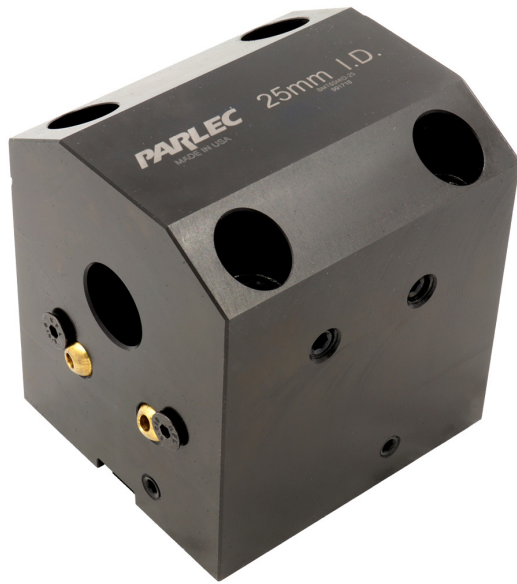

- OEM-level quality ensures optimal performance
- Made from ductile iron for superior vibration damping and improved cutting performance
- 100% made-in-USA
- For 25mm diameter tooling

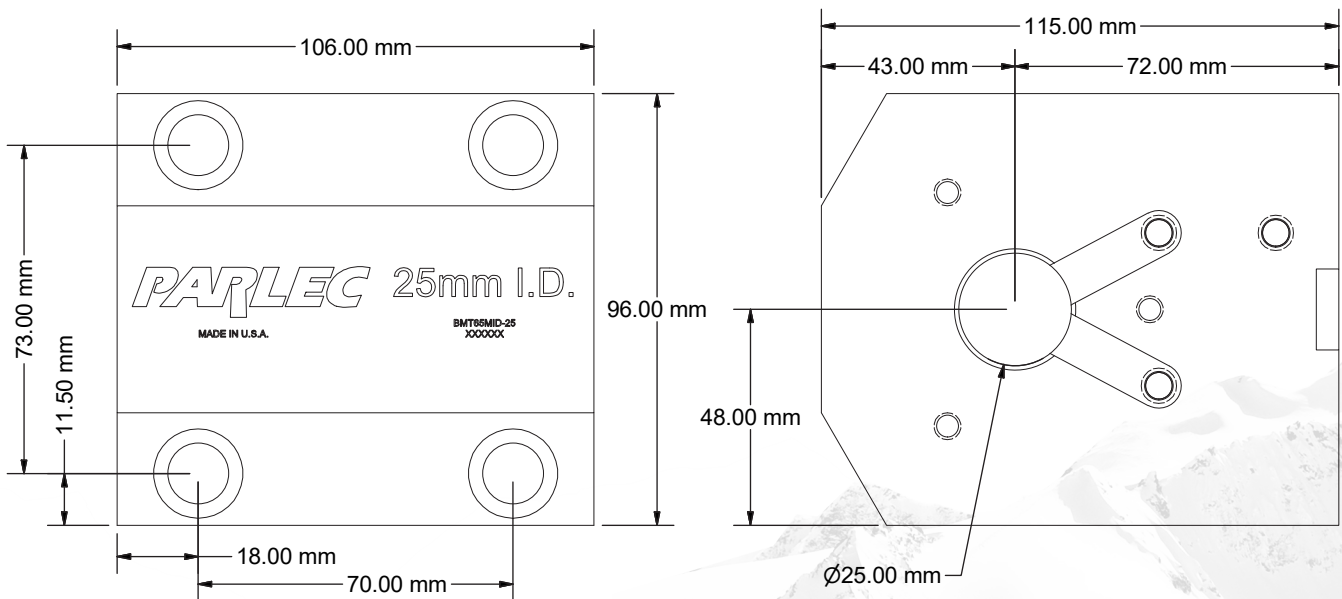

Always 100% made in the USA



Part #: BMT65ID-1.50-PARLEC

\$ 280.00

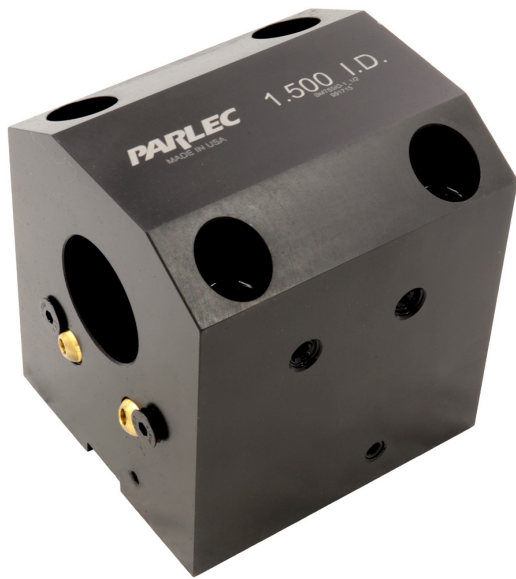

- OEM-level quality ensures optimal performance
- Made from ductile iron for superior vibration damping and improved cutting performance
- 100% made-in-USA
- For 1.5" diameter tooling

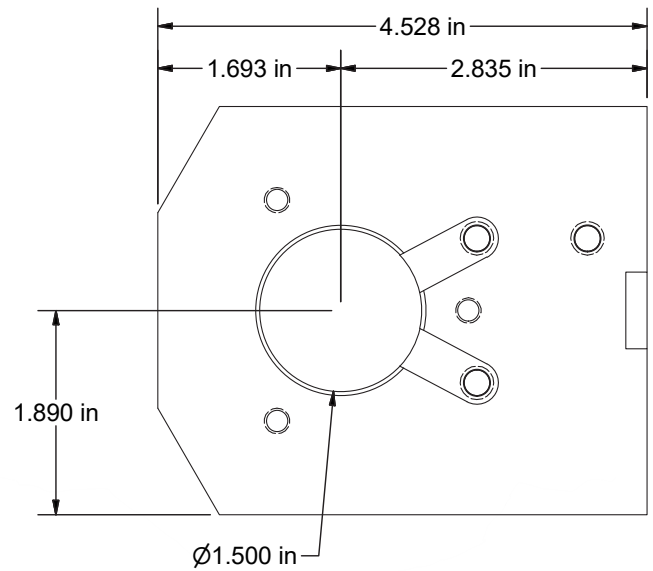
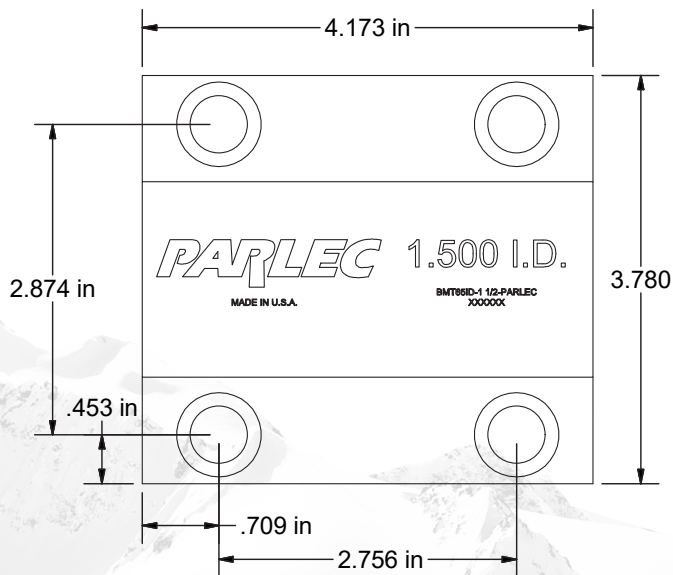



Part #: BMT65MID-40-PARLEC

\$ 280.00

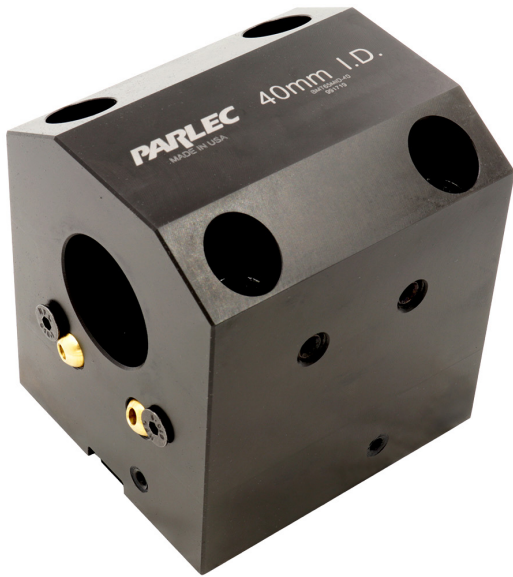

- OEM-level quality ensures optimal performance
- Made from ductile iron for superior vibration damping and improved cutting performance
- 100% made-in-USA
- For 40mm diameter tooling

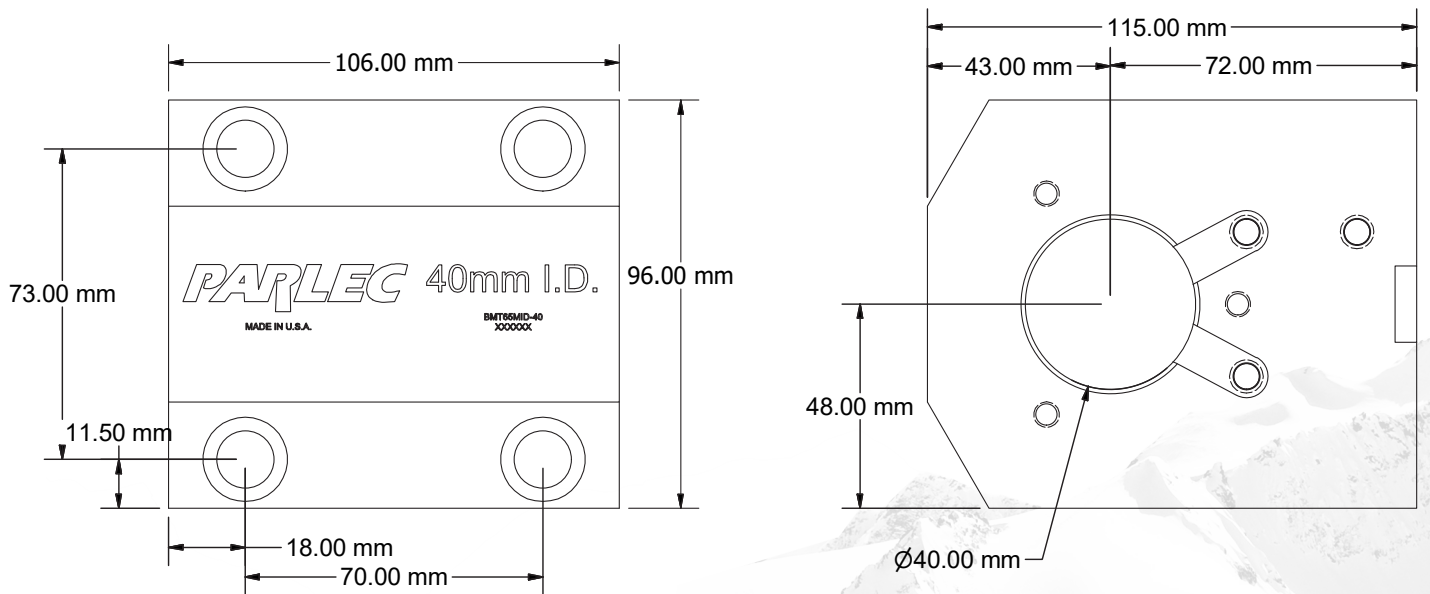

Always 100% made in the USA



Part #: BMT65ID-1.25T-PARLEC (double-sided)

\$ 405.00



- OEM-level quality ensures optimal performance
- Made from ductile iron for superior vibration damping and improved cutting performance
- 100% made-in-USA
- For 1.25" diameter tooling
- Double-sided

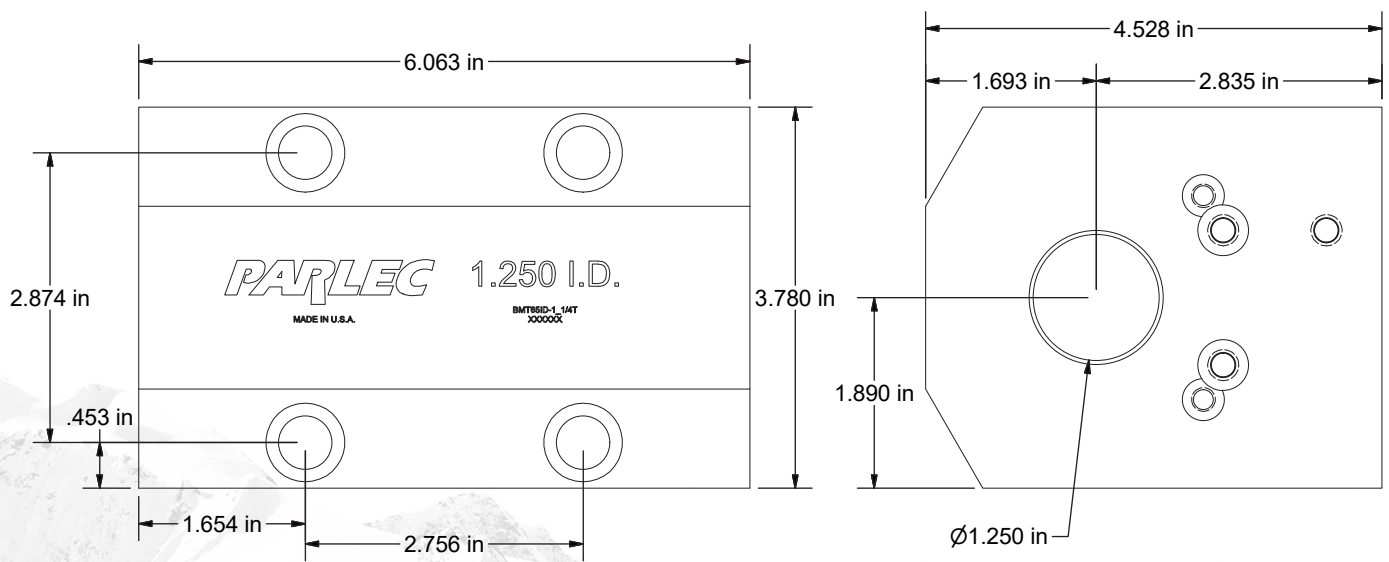

Part #: BMT650D-1-PARLEC

\$ 350.00



- OEM-level quality ensures optimal performance
- Made from ductile iron for superior vibration damping and improved cutting performance
- 100% made-in-USA
- For 1" square tooling

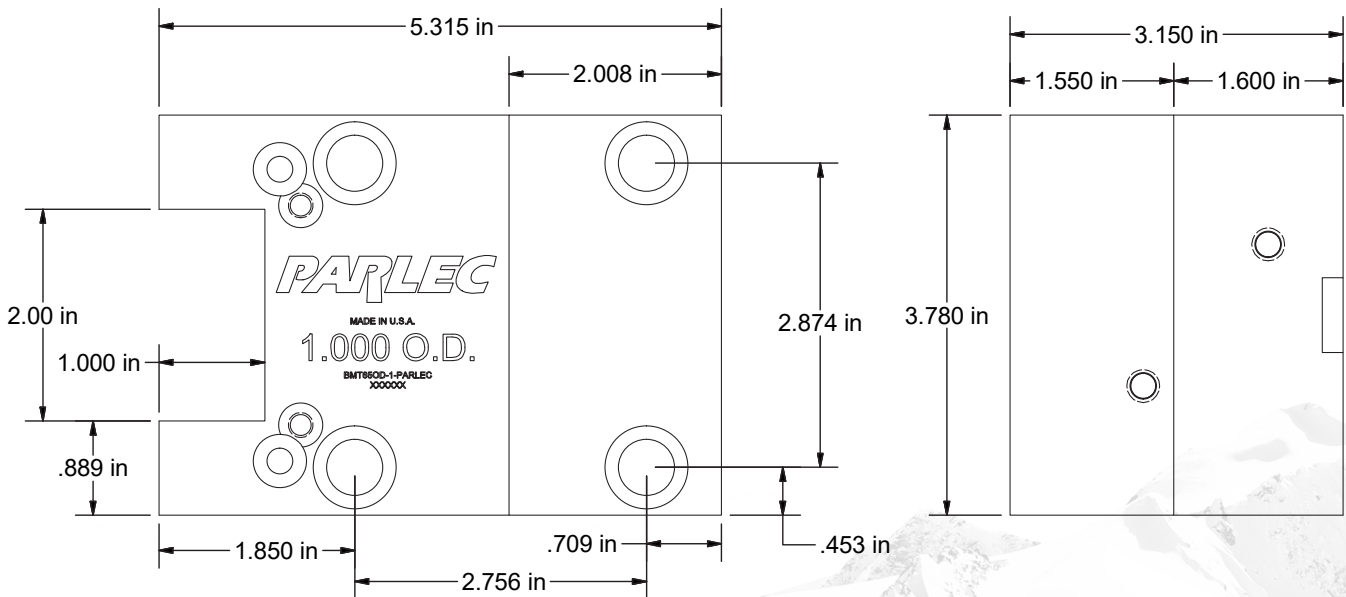

Always 100% made in the USA



Part #: BMT65MOD-25-PARLEC

\$ 350.00



- OEM-level quality ensures optimal performance
- Made from ductile iron for superior vibration damping and improved cutting performance
- 100% made-in-USA
- For 25mm square tooling

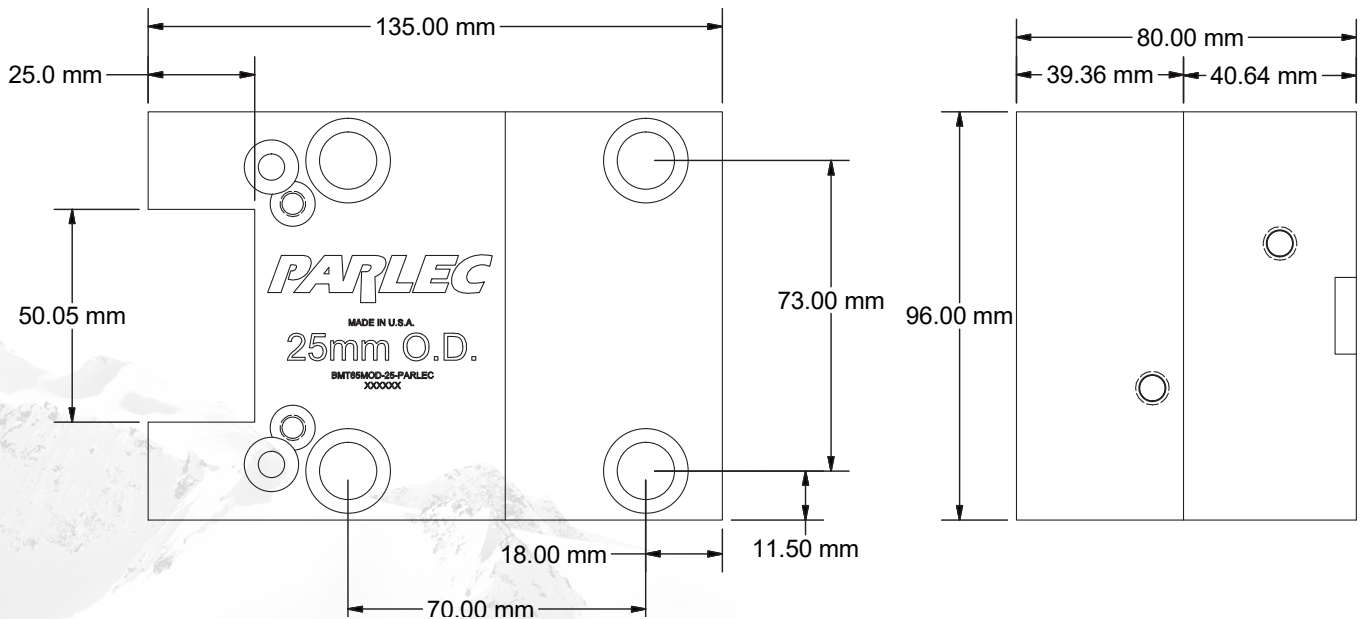



Part #: BMT65OD-1T-PARLEC

\$ 475.00



- OEM-level quality ensures optimal performance
- Made from ductile iron for superior vibration damping and improved cutting performance
- 100% made-in-USA
- For 1" square tooling
- Double-sided

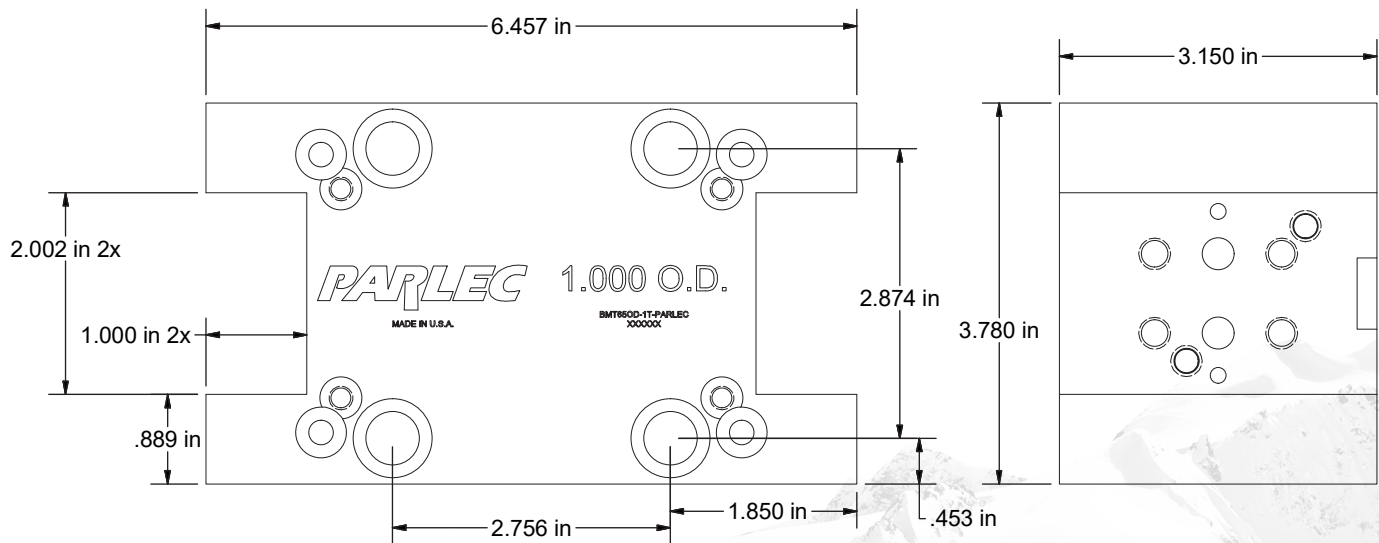

Always 100% made in the USA



Part #: BMT65MOD-25T-PARLEC

\$ 475.00



- OEM-level quality ensures optimal performance
- Made from ductile iron for superior vibration damping and improved cutting performance
- 100% made-in-USA
- For 25mm square tooling
- Double-sided

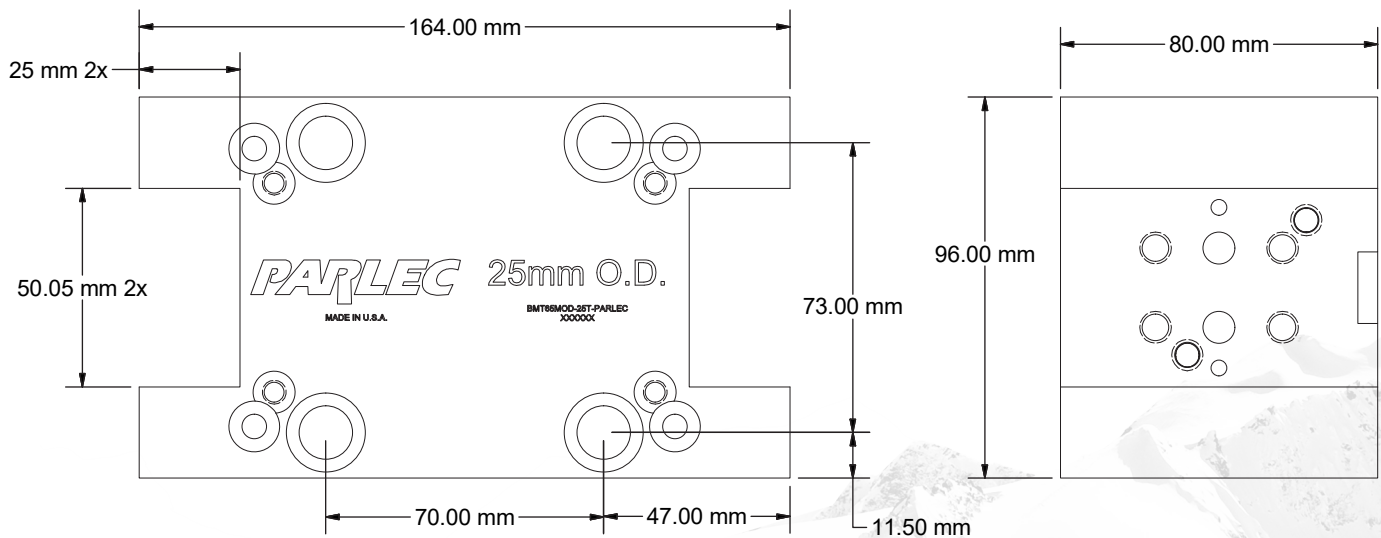

**COMPLETE  
METALWORKING  
SOLUTIONS**

(800) 991-4225

[www.ahbinc.com](http://www.ahbinc.com)

ISO Certified

[customerservice@ahbinc.com](mailto:customerservice@ahbinc.com)