

PARLEC
Measurably Better

Your **total** machining solution.

AHB
TOOLING & MACHINERY, INC.

COMPLETE
METALWORKING
SOLUTIONS

(800) 991-4225

www.ahbinc.com

ISO Certified

customerservice@ahbinc.com

ENGINEERED SOLUTIONS

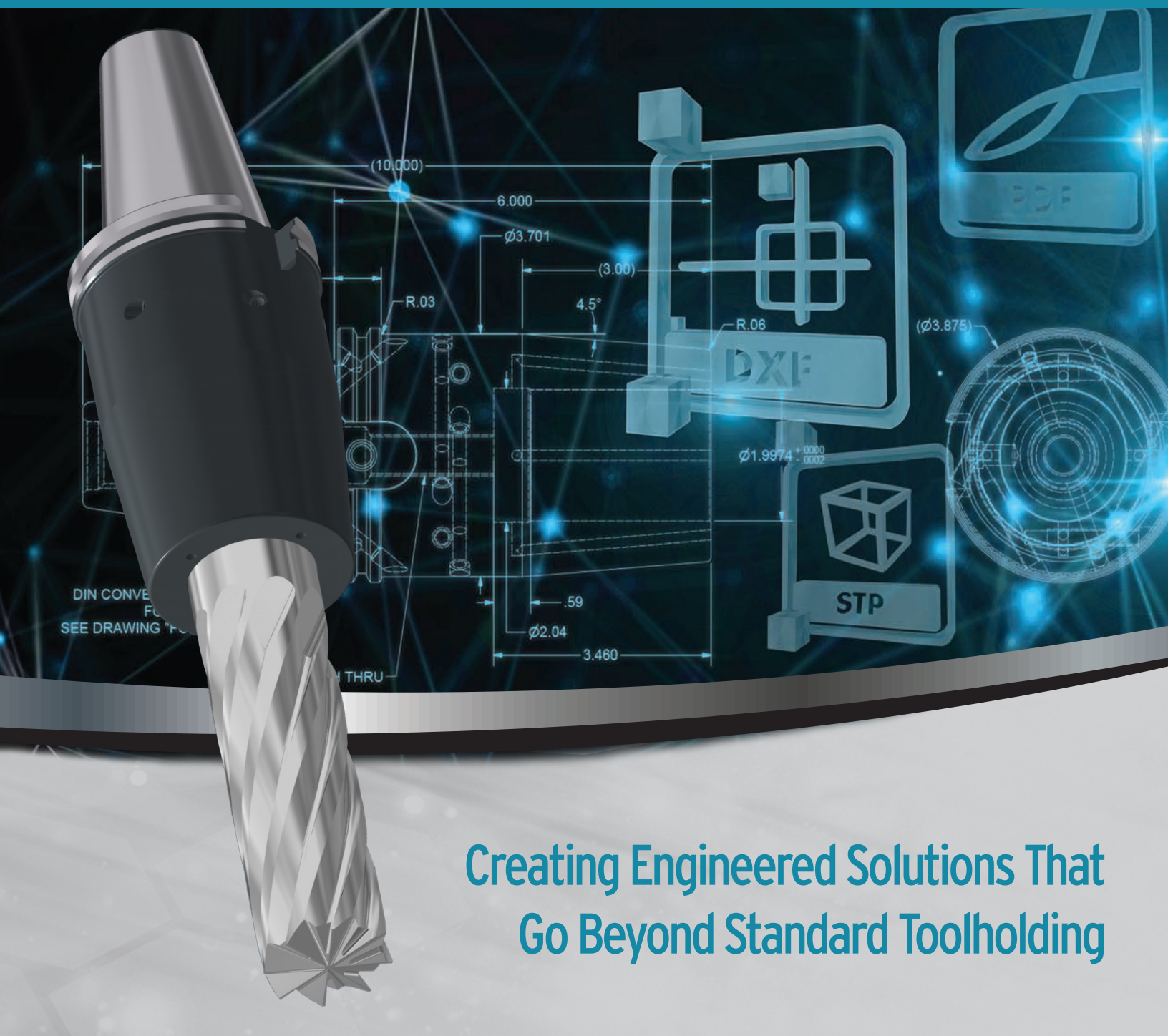

Creating Engineered Solutions That
Go Beyond Standard Toolholding



Parlec is a proud member of Techniks Tool Group.

CNC TOOLING SOLUTIONS
FROM SPINDLE TO WORKPIECE

Connect with Techniks Tool Group
info@technikstoolgroup.com



ENGINEERED SOLUTIONS

Optional Features

Not in a catalog? No problem.

We can make it! **FAST!**

Parlec applies engineering, innovation, and quality to create engineered solutions that go beyond standard tool holding.

SIMULFIT®

Dual-contact taper holders compatible with BIG-PLUS®, Ingersoll, & custom spindles.

BALANCE HOLES

Add balance holes to any configuration.

GAUGE LENGTH

Custom built to your exact gage length specifications.

INTERFACE TYPES

- Shrink Fit (standard & heavy wall)
- Facemill Holders (standard & coolant)
 - ER Collet Chucks (BT, CAT, HSK)
 - **AEROSPACE Custom Solutions**

TAPER

Choose from CAT, BT, DIN, NMTB, or HSK options. Other taper options available on request.

COOLANT INPUT

Available standard or flange entry AD/B coolant supply.

OPTIONAL CHIP HOLE

RFID Pocket designed to hold Data Carrier Chip. Select size and location.

COOLANT OUTPUT

Available coolant ports and grooves

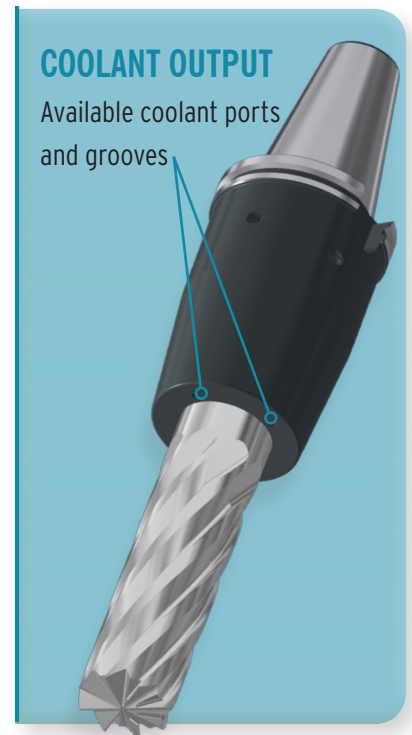

ENGINEERED SOLUTIONS

Custom Engineered Solutions

Parlec PC Modular System

Our modular solutions provide immediate availability of standard components for your most demanding custom applications. Choose from our line of modular shanks and toolholder adapters for your specific spindle type and job.



MODULAR MILLING & DRILLING



MODULAR TAPPING



MODULAR BORING

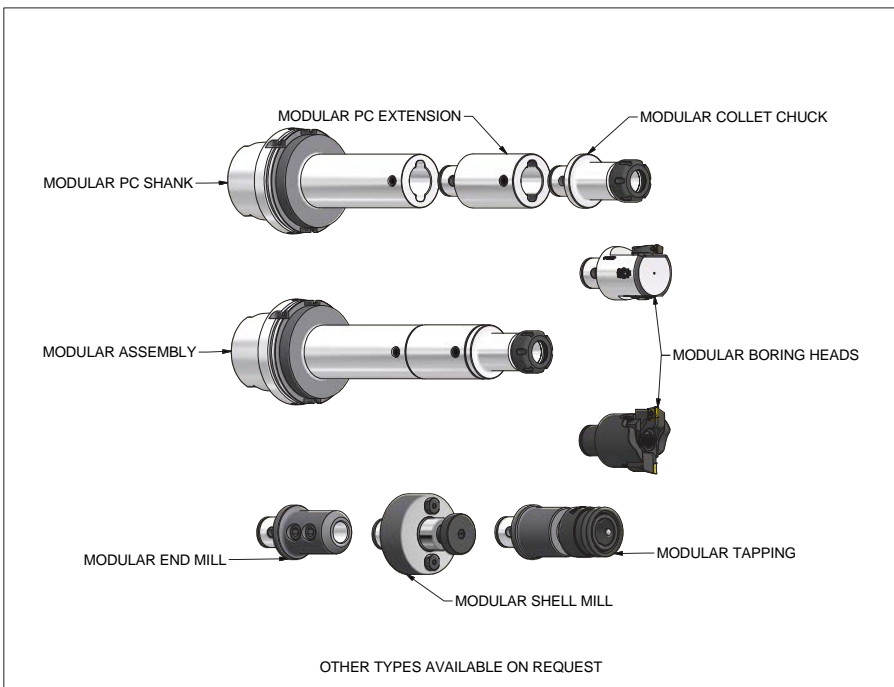

ENGINEERED SOLUTIONS

Custom Engineered Solutions

Engineered Solutions

- Engineered custom tool holders built to your exact specifications
- Ultra fast quoting
- Short lead times
- Competitive pricing

Manufacturing

- Over 70 years of manufacturing experience
- Parlec is an ISO:9001 Certified Manufacturer
- All holders are manufactured in a state-of-the-art manufacturing facility located in the Rochester, NY area

Innovation

- Let Parlec's team of dedicated engineers help solve your most challenging problems

Dedicated to American Manufacturing.

Parlec has invested millions of dollars on CNC machines and software at our Fairport, NY facility, increasing our manufacturing capacity. Our dedicated quick-turn "specials" cell allows us to deliver custom solutions quickly for your specific applications.



Parlec is a proud member of Techniks Tool Group.

**CNC TOOLING SOLUTIONS
FROM SPINDLE TO WORKPIECE**

AHB
TOOLING & MACHINERY, INC.

**COMPLETE
METALWORKING
SOLUTIONS**

(800) 991-4225

www.ahbinc.com

ISO Certified

customerservice@ahbinc.com