



COMPLETE  
METALWORKING  
SOLUTIONS

(800) 991-4225  
www.ahbinc.com  
ISO Certified  
customerservice@ahbinc.com

**PARLEC**

by



## EVOLUTION LINE ANGLE HEADS



## HISTORY

- 1948 Parlec is established in Rochester N.Y., as a job shop specializing in the manufacturing of Sulky Hubs.
- 1973 Parlec begins producing and distributing the Numertap and Autofacer product lines.
- 1977 Parlec expands its product line with the introduction of Toolholders, which are sold as Numertap and Autofacer accessories.
- 1980 The first Parsetter TMM is produced.
- 1985 Parlec builds a new 42,000 square-foot, state-of-the-art manufacturing facility just outside of Rochester in Fairport, N.Y.
- 1992 Parlec begins to manufacture and distribute its own line of Boring Tools.
- 1997 Parlec becomes ISO 9001 certified. Parlec's sales triple from 1992-1997.
- 1998 Parlec further enhances its product line to include Workholding. Construction of a 58,000 square-foot plant addition begins.
- 2003 Parlec enters the Asian market with the opening of a sales and service office in Nanjing China.
- 2004 Parlec acquires Bristol Tool. Driven and static tools are added to Parlec's extensive product line. A new sales, engineering and distribution facility opens in Bristol, England.
- 2006 Parlec continues to expand its world wide footprint by opening a Wholly Owned Foreign Enterprise in Nanjing. This gives the company full sales, engineering, customer support and distribution capabilities on 3 continents.
- 2008 Parlec partners with Mahr GMBH for distribution of Tool Presetters in Europe.
- 2009 Sales offices are opened in Tianjin, Xian, Wuxi, and Chengdu to expand the China presence.
- 2010 Parlec partners with Gerardi for distribution of Driven & Static Tooling in Europe. Parlec begins distribution of Right angle heads in China.
- 2012 Parlec successfully completes a \$5 million dollar capital investment campaign to automate and expand its manufacturing capabilities in the United States.



## Total Machining Solutions:

**Ps**

Tool Presetting, Measuring  
and Inspection Systems

**Tt**

Widest Range of Rigid, Tension  
and Compression Tapping

**Bt**

Precision Modular  
Boring Systems

**Th**

Toolholding Production and  
High Performance Solutions

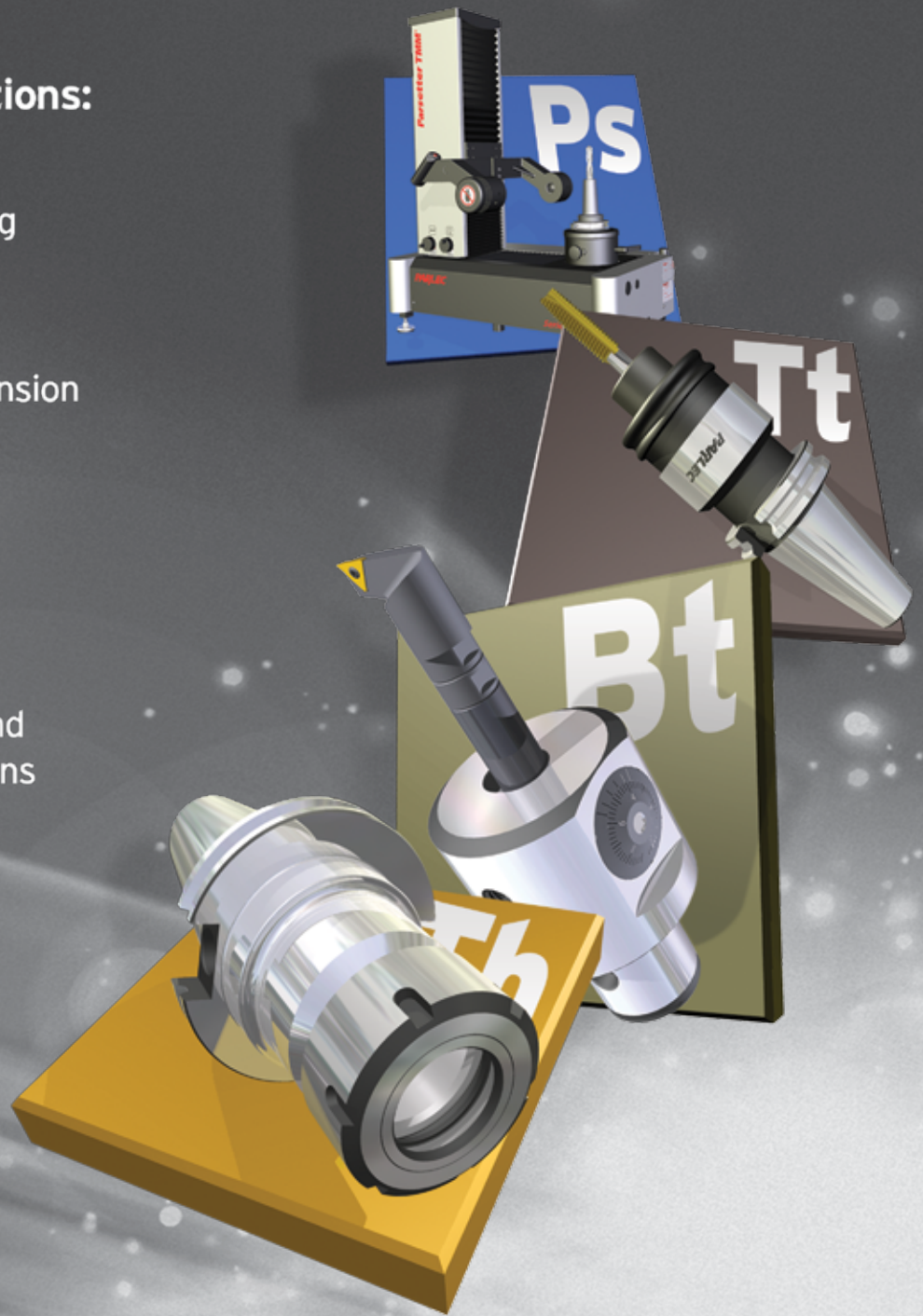

**Quality, Precision and Innovation**

That's the **POWER** of

**PARLEC**  
Measurably Better



# Table of Contents

## APPLICATION GUIDE

Technical Features ..... 3-7  
 Interchangeable Drive Tapers ..... 4  
 Cost savings ..... 5  
 ATC / MTC Series Evolution Line ..... 6-7

## AUTOMATIC TOOL CHANGE (ATC) SERIES EVOLUTION LINE

ATC Series Evolution Line ..... 8  
 ATC Internal Coolant & Output Options ..... 9  
 FS90-3 ..... 10  
 FS90-3L ..... 11  
 FS90-4 ..... 12  
 FS90-4L ..... 13  
 F90-7, F90-7C and F90-7D ..... 14-15  
 F90-7L, F90-7LC and F90-7LD ..... 16-17  
 F90-10, F90-10C and F90-10D ..... 18-19  
 F90-10L, F90-10LC and F90-10LD ..... 20-21  
 F90-16S, F90-16SC and F90-16SD ..... 22-23  
 F90-16, F90-16C and F90-16D ..... 24-25  
 F90-16L, F90-16LC and F90-16LD ..... 26-27  
 F90-20, F90-20C and F90-20D ..... 28-29  
 F90-40, F90-40C and F90-30D ..... 30-31  
 FR90-10 ..... 32  
 FR90-16 ..... 33  
 FR90-20 ..... 34  
 FMU-10 ..... 35  
 FMU-16 ..... 36  
 FMU-20 ..... 37

## MANUAL TOOL CHANGE (MTC) SERIES EVOLUTION LINE

MTC Series Evolution Line ..... 38  
 MTC Internal Coolant & Double Output Options ..... 39  
 F90MTC-16 ..... 40  
 F90MTC-16L ..... 41  
 F90MTC-20 ..... 42  
 F90MTC-20L ..... 43  
 F90MTC-40 ..... 44

## ATC & MTC ACCESSORIES

Introduction ..... 45  
 Collets, Nuts and Wrenches ..... 46  
 Collet Performance Selection Guide ..... 47  
 ER Standard Collets ..... 48-50  
 ER Tap Collets ..... 51  
 ER Grade AA 5 Micron Collets ..... 52-54  
 ERS Steel Sealed Collets ..... 55-56  
 Coolant Nut Seals ..... 57  
 Anti-Rotation ..... 58  
 Stop-Block ..... 59  
 Stop-Block Mounting Example ..... 60  
 Angle Head Mounting Example ..... 61  
 MTC Accessories ..... 62  
 MTC Angle Head Mounting Example ..... 63  
 Quotation Request Sheet ..... 64-65  
 Notes ..... 66







## EVOLUTION LINE

The Evolution line of Parlec by Gerardi angle heads has been designed from a technical base derived from 40 years experience in solving thousands of production problems, finding optimum solutions and always guaranteeing the highest product quality. Standard angle head types are now offered, designed, built and distributed in more than 50 countries around the world by Gerardi S.p.A., and available with a range of options to complete their application and performance potentials.

## TECHNICAL FEATURES

1. Minimum thermal expansion and high corrosion resistant treated steel body.
2. Modularity: main shaft with interchangeable Drive Taper (Double contact) allows an EVOLUTION angle head to be used on other machining centers with different spindle types and sizes. It is also possible to exchange the anti-rotation (arrester) sub-assembly and the input drive taper with no effect on rigidity or accuracy.
3. All spindles are supported by pairs of preloaded angular contact ball bearings with ABEC 7/9 precision and long life lubrication.
4. Gleason computer based calculations for the Gleason cut spiral bevel drive gears with ground teeth in order to guarantee a greater torque.
5. More than 42 angle head types available.
6. Among the new range of angle head types the slim series have reduced weights and overall dimensions. The Slim series are even able to enter a minimum diameter of 35mm.
7. Up to 150 PSI (10 bar) coolant through the pin included in the standard heads. Options include feeding coolant at 150 PSI (10 bar) through the cutter spindle or at up to 1000 PSI (70 bar) through the machine.
8. Designed for superior heat dissipation and for sustained periods of high speed operations.
9. 100% compatibility with heads installed during the last 40 years (same anti-rotation/arrester pin and stop block dimensions).
10. Parlec by Gerardi Evolution angle heads have been designed and are manufactured in Italy. They are covered by 1 year warranty.

## ATC SERIES

from page 8 to 37



ATC angle heads are ideal for CNC machines with automatic tool change and can be automatically transferred from the tool store to the machine spindle and vice-versa.

The orientation ring and arrester arm support ring are both 360° adjustable to allow the best angular orientation. On FMU heads, the cutter spindle housing can be adjusted at  $\pm 90^\circ$ .

If an ATC angle head is not placed into the machine spindle, a locking system prevents shank rotation relative to the head body.

## MTC SERIES

from page 38 to 44



This range of angle heads is for conventional machines without automatic tool change. MTC angle heads (Manual Tool Change) are manually mounted on the machine headstock through a flange. On FMU heads, the cutter spindle housing can be adjusted at  $\pm 90^\circ$ .





### ONE HEAD FOR MANY MACHINES

Interchangeable drive tapers to suit any machine spindle!



A CHOICE OF MODULAR INTERCHANGEABLE ARRESTER PINS

The unique Gerardi taper and face location ensures rigidity and accuracy!

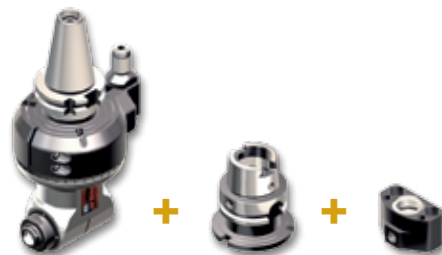

**QUICKEST RETURN ON YOUR INVESTMENT!**





### THE SAME MACHINE WITH MANY HEADS

A system that reduces inventory costs!

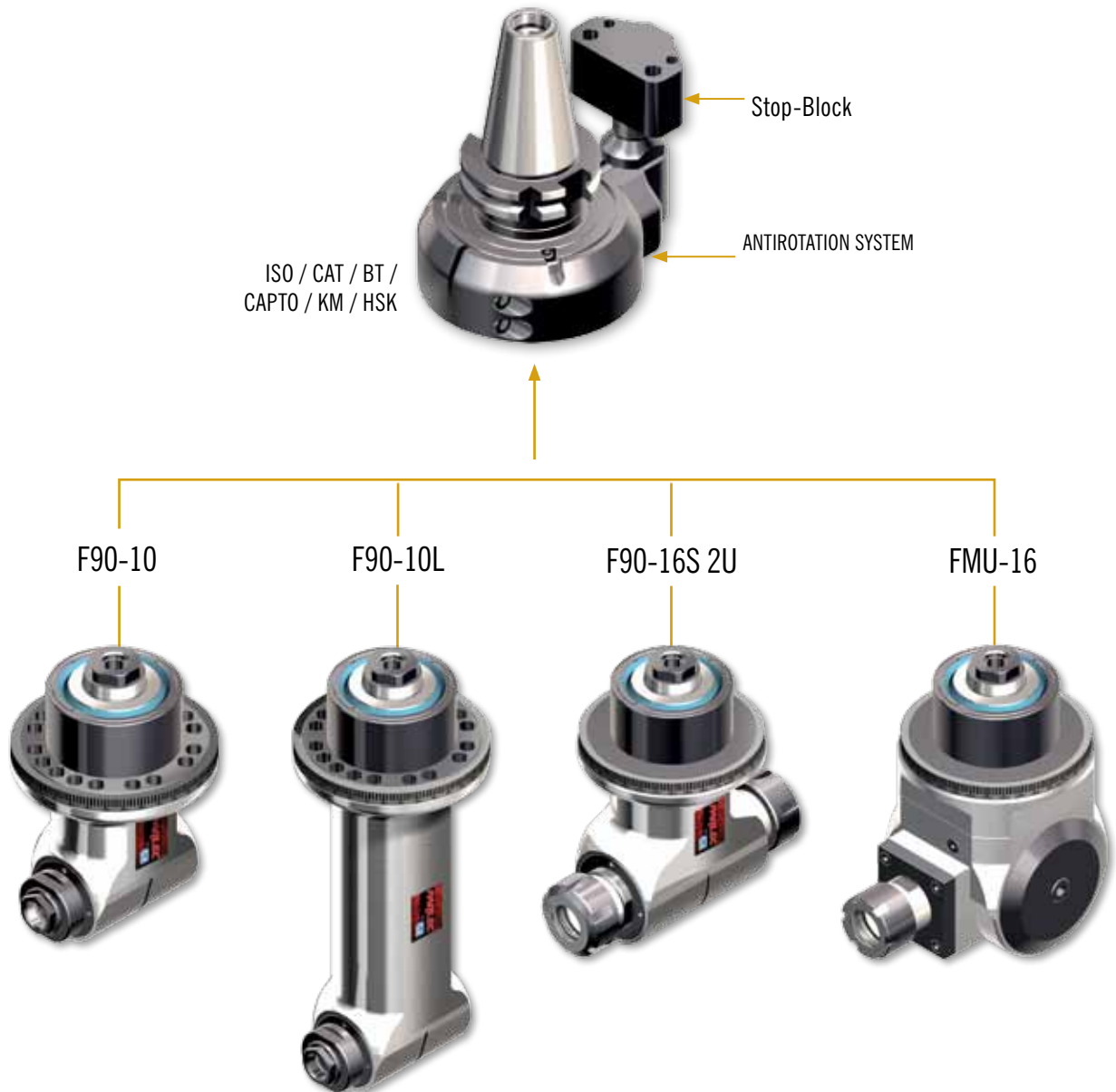

**BE READY FOR TOMORROW WITH THE HEAD YOU BUY TODAY !!**



# ATC SERIES *EVOLUTION LINE*

## AUTOMATIC TOOL CHANGE

### DESIGN

The Compact design, along with mentioned specifications, allows for high performance speeds, and long tool life.

Case hardened and ground shank

Modular antirotation group

Graduated retaining ring

### OUTPUT

- ER collet (standard)
- Weldon
- Shell mill holder
- Special

### BEARINGS

Angular contact preloaded ball bearings of precision class ABEC 7/9

### GEARS

Gleason ground spiral bevel gears maximum performances and minimum vibration



Positioning pin with automatic release

Standard 150PSI (10 bar) coolant through the pin

Treated steel body with 360° position and optional internal air pressure, maximum rigidity and corrosion resistant. Minimum thermal expansion

Precision/lapped surface for accurate alignment

### STOP BLOCK

with case hardened bushing and gasket







# MTC SERIES *EVOLUTION LINE*

## MANUAL TOOL CHANGE

This range of angle heads is for conventional machines without automatic tool change. MTC angle heads (Manual Tool Change) are manually mounted on the machine headstock through a flange.

### DESIGN

The Compact design, along with mentioned specifications, allows: highest performances, high speeds, long tool life



Case hardened and ground shank and shaft

Universal flange

Graduated retaining ring

### Output:

- ER collet (standard)
- Weldon
- Shell mill holder
- Special

Treated steel body with 360° position and optional internal air pressure, maximum rigidity and corrosion resistant. Minimum thermal expansion

### BEARINGS

Angular contact preloaded ball bearings of precision class ABEC 7/9



### GEARS

Gleason ground spiral bevel gears maximum performances and minimum vibration





# ATC SERIES *EVOLUTION LINE*

## AUTOMATIC TOOL CHANGE



### SLIM Series

Ideal for micromachining in narrow spaces.

	35 @ 3 MM tool shank - 39 @ 4 MM tool shank	
<b>Application</b>	1:1	8,000 RPM
<b>Projection</b>	225-260 MM	
<b>Coolant</b>	External piping through the pin	



### Milling Series

Ideal for milling, drilling, tapping at 90°.



### Long Series

Ideal for machining at extreme positions.

	68 @ 7 MM tool shank - 94 @ 10 MM tool shank		
<b>Application</b>	1:1	10,000 RPM	Opt. dual output spindles available
<b>Projection</b>	150-250 MM		
<b>Coolant</b>	External piping through the pin Optional through tool piped through the pin		

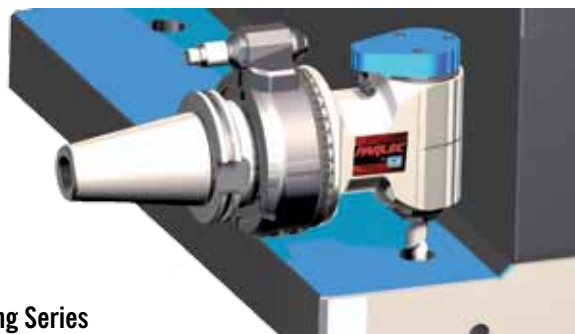

### Milling Series with Coolant Option

With coolant input from positioning pin and output through the tool.

	94 @ 10 MM tool shank - 187 @ 40 taper output		
<b>Application</b>	1:1	2,500-10,000 RPM	Optional dual output spindles available
<b>Projection</b>	150-275 MM		
<b>Coolant</b>	External piping through the pin Optional through tool piped through the pin		



### Offset Series

Ideal for machining in narrow spaces with coolant input directly from machine spindle and output through the tool at 1,000 PSI.

	73 @ 10 MM tool diameter	
<b>Application</b>	1:1	3,500 - 6,000 RPM
<b>Projection</b>	185-230 MM	
<b>Coolant</b>	1,000 PSI through spindle coolant	



### Angular Series

Adjustable output at  $\pm 90^\circ$  for angular drilling, milling and tapping.

	35 @ 3 MM tool shank - 39 @ 4 MM tool shank	
<b>Application</b>	1:1	8,000 RPM
<b>Projection</b>	225-260 MM	
<b>Coolant</b>	External piping through the pin	





### INTERNAL COOLANT OPTION ATC SERIES



**F90-16**  
(Example shown here)

Standard 150 PSI (10 bar) coolant through the positioning pin. Coolant piping can be added to direct the coolant towards the cutting edge. Alternately piping can be used for low air pressure to keep residual coolant from entering gear box.



**F90-16C 150 PSI (10bar)**  
(Example shown here)

Coolant through the positioning pin and the tool, by rotating coolant seal distributor. All plumbing is supplied for customer application assembly.



**FR90-16S 1000 PSI (70bar)**  
(Example shown here)

**COOLANT SYSTEM FROM MACHINE**  
The offset design of the FR90 angle head series utilizes high pressure seals which allows coolant through the spindle up to 1000 PSI (70bar).

### DOUBLE OUTPUT OPTION ATC SERIES



**F90-16SD**  
(Example shown here)

All double output heads have one collet chuck that turns with the machine spindle and one that turns opposite.

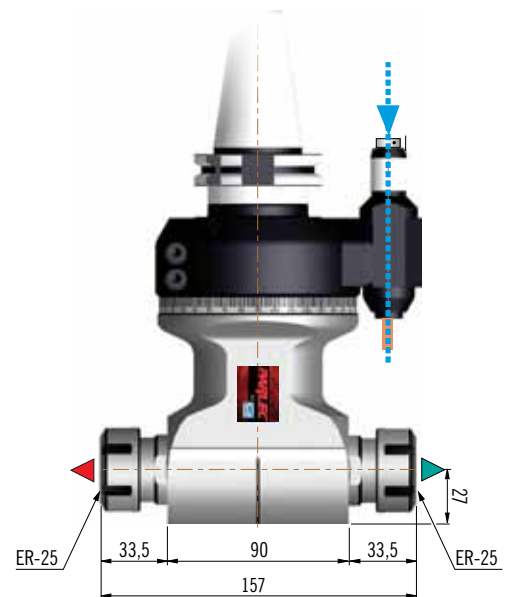



### FS90-3

Anti-Rotation Interchangeability: **TYPE 1** (See page 52)

Option type 2 and 3 anti-rotation available.

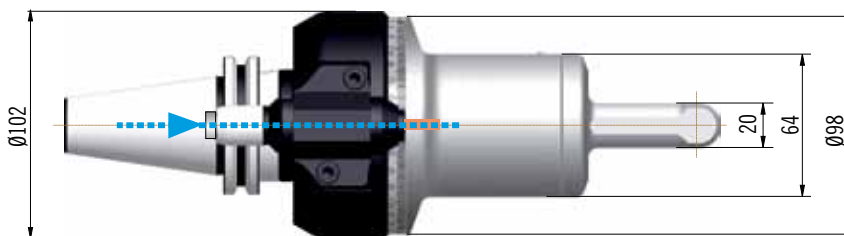
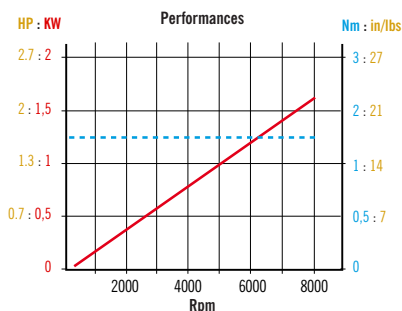
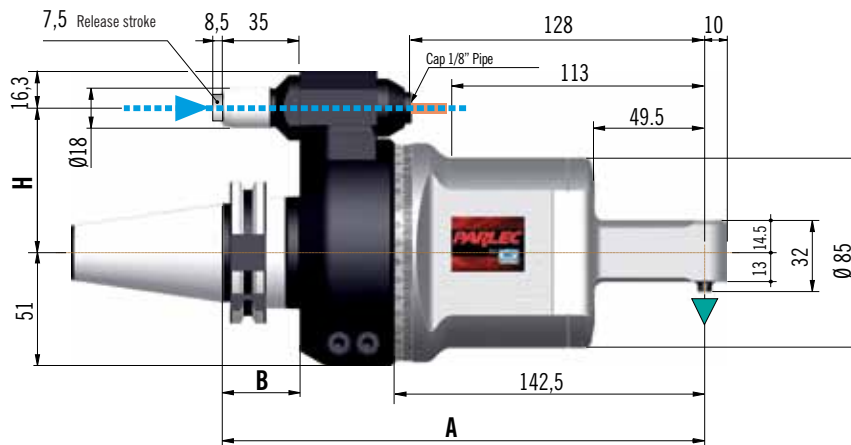

### APPLICATION SPECIFICATION

Output Shaft	Range	Ratio	RPM Max	Axial Load Max	Torque	Coolant	Direction
6023E	1- 3 mm	1:1	8,000	16 lbs (70 N)	17.7 in/lbs (2 Nm)	Positioning Pin	Same Spindle
<i>Configured for optional internal air pressure</i>							

### PRODUCT

Description	Shank	A	B	H	H Options	Weight	Spares Included
FS90-3-C40	CAT 40	8.52 (216.5)	1.38 (35)	2.559 (65)	H=3.149 (80)	12.1 lbs (5.5 Kg)	Stop Block Wrenches Grease Instructions
FS90-3-B40	BT 40	8.52 (216.5)	1.38 (35)	2.559 (65)	H=3.149 (80)	12.1 lbs (5.5 Kg)	
FS90-3-C50	CAT 50	8.52 (216.5)	1.38 (35)	3.149 (80)		16.5 lbs (7.5 Kg)	
FS90-3-H63	HSK63A	8.87 (225.5)	1.73 (44)	2.559 (65)	H=3.149 (80)	12.1 lbs (5.5 Kg)	
FS90-3-H100	HSK100A	8.87 (225.5)	1.81 (46)	3.149 (80)		16.5 lbs (7.5 Kg)	
Other Shank Options available: C5, C6, C8 (ISO 26623) and KM 63							

Order 6023E Collets separately. See page 46.



FS90-3L

Anti-Rotation Interchangeability: TYPE 1 (See page 52)

Option type 2 and 3 anti-rotation available.

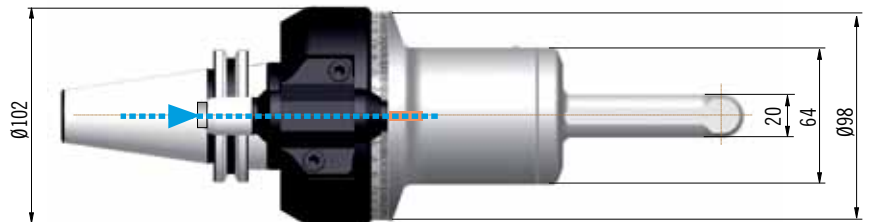
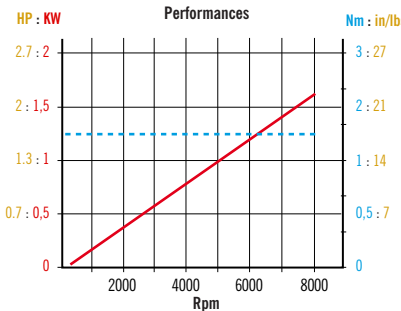
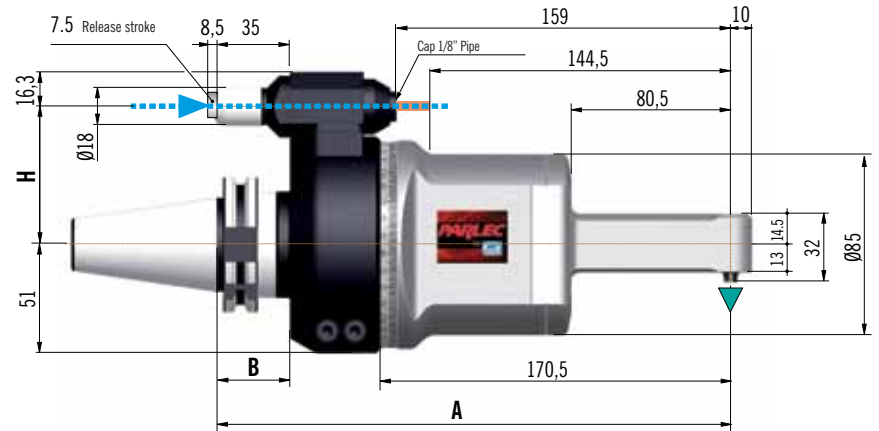

APPLICATION SPECIFICATION

Output Shaft	Range	Ratio	RPM Max	Axial Load Max	Torque	Coolant	Direction
6023E	1- 3 mm	1:1	8,000	16 lbs (70 N)	17.7 in/lbs (2 Nm)	Positioning Pin	Same Spindle
<i>Configured for optional internal air pressure</i>							

PRODUCT

Description	Shank	A	B	H	H Options	Weight	Spares Included
FS90-3L-C40	CAT 40	9.75 (247.5)	1.38 (35)	2.559 (65)	H=3.149 (80)	14.1 lbs (6.4 Kg)	Stop Block Wrenches Grease Instructions
FS90-3L-B40	BT 40	9.75 (247.5)	1.38 (35)	2.559 (65)	H=3.149 (80)	14.1 lbs (6.4 Kg)	
FS90-3L-C50	CAT 50	9.75 (247.5)	1.38 (35)	3.149 (80)		19 lbs (8.6 Kg)	
FS90-3L-H63	HSK63A	10.10 (255.5)	1.73 (44)	2.559 (65)	H=3.149 (80)	14.1 lbs (6.4 Kg)	
FS90-3L-H100	HSK100A	10.10 (255.5)	1.81 (46)	3.149 (80)		19 lbs (8.6 Kg)	

Other Shank Options available: C5, C6, C8 (ISO 26623) and KM 63

Order 6023E Collets separately. See page 47-51.





### FS90-4

Anti-Rotation Interchangeability: TYPE 1 (See page 52)

Option type 2 and 3 anti-rotation available.

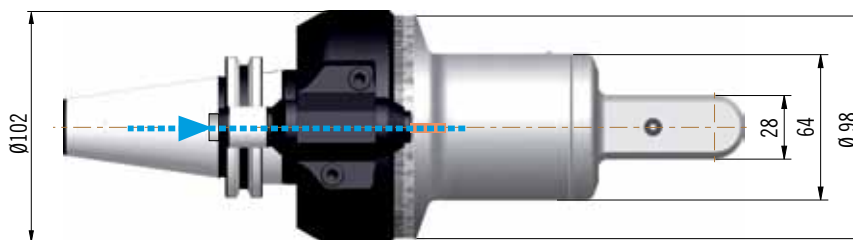
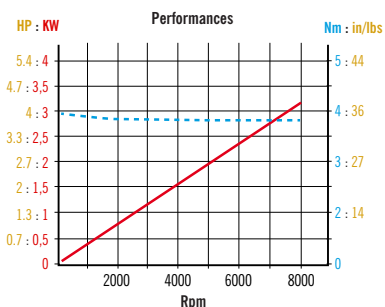
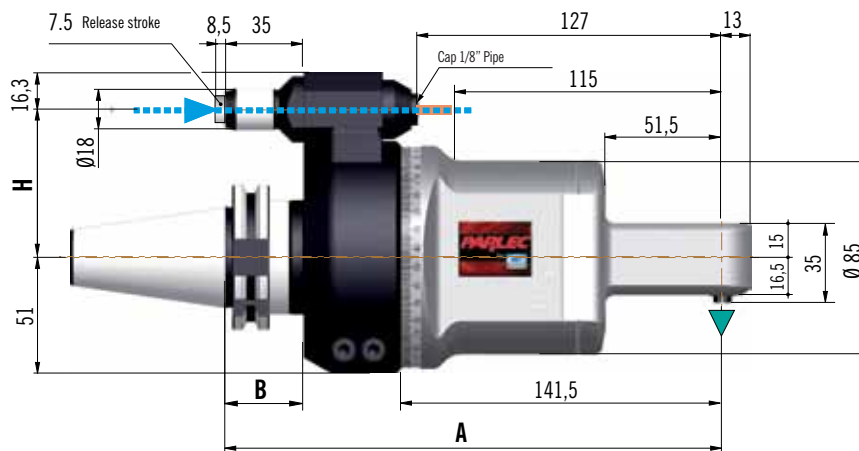

### APPLICATION SPECIFICATION

Output Shaft	Range	Ratio	RPM Max	Axial Load Max	Torque	Coolant	Direction
600E	1- 4 mm	1:1	8,000	27 lbs (120 N)	31 in/lbs (3.5 Nm)	Positioning Pin	Same Spindle
<i>Configured for optional internal air pressure</i>							

### PRODUCT

Description	Shank	A	B	H	H Options	Weight	Spares Included
FS90-4-C40	CAT 40	8.60 (218.5)	1.38 (35)	2.559 (65)	H=3.149 (80)	12.1 lbs (5.5 Kg)	Stop Block Wrenches Grease Instructions
FS90-4-B40	BT 40	8.60 (218.5)	1.38 (35)	2.559 (65)	H=3.149 (80)	12.1 lbs (5.5 Kg)	
FS90-4-C50	CAT 50	8.60 (218.5)	1.38 (35)	3.149 (80)		16.5 lbs (7.5 Kg)	
FS90-4-H63	HSK63A	8.76 (222.5)	1.73 (44)	2.559 (65)	H=3.149 (80)	12.1 lbs (5.5 Kg)	
FS90-4-H100	HSK100A	8.76 (222.5)	1.81 (46)	3.149 (80)		16.5 lbs (7.5 Kg)	
Other Shank Options available: C5, C6, C8 (ISO 26623) and KM 63							

Order ER11 Collets separately. See pages 47-51.



FS90-4L

Anti-Rotation Interchangeability: TYPE 1 (See page 52)

Option type 2 and 3 anti-rotation available.

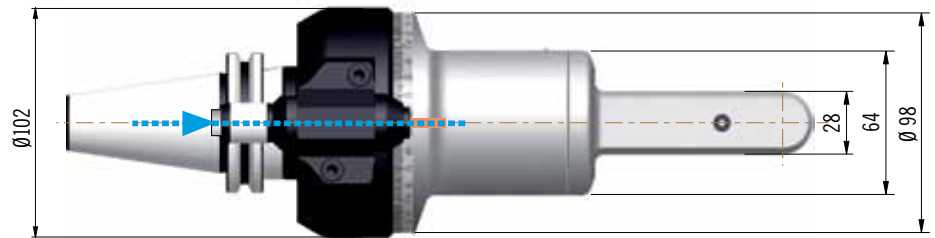
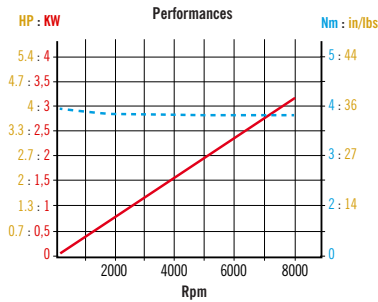
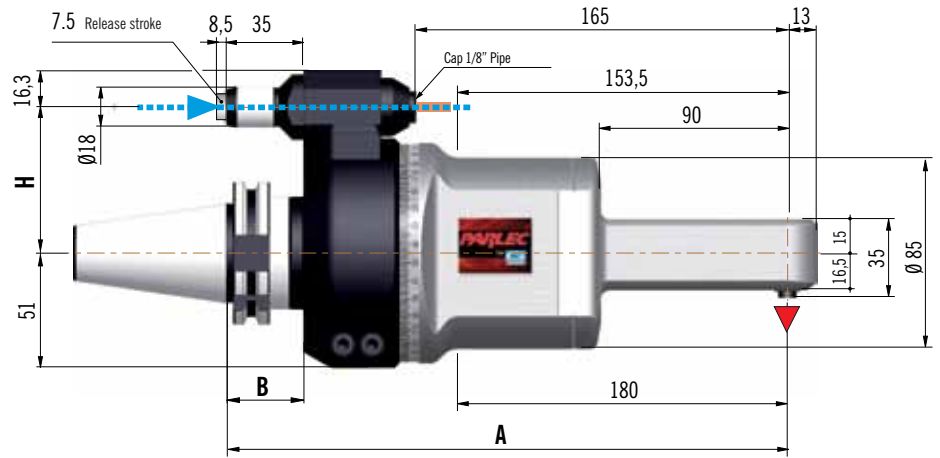
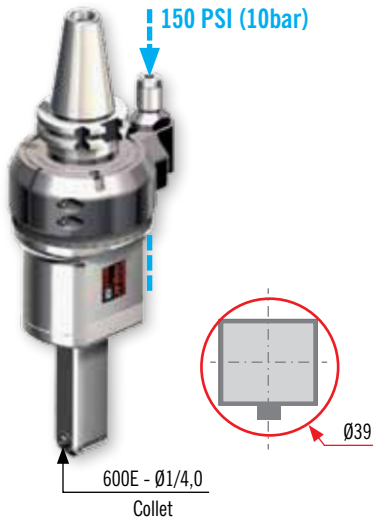

**DRY RUNNING NOT POSSIBLE**

APPLICATION SPECIFICATION

Output Shaft	Range	Ratio	RPM Max	Axial Load Max	Torque	Coolant	Direction
600E	1- 4 mm	1:1	8,000	27 lbs (120 N)	31 in/lbs (3.5 Nm)	Positioning Pin	Same Spindle
<i>Configured for optional internal air pressure</i>							

PRODUCT

Description	Shank	A	B	H	H Options	Weight	Spares Included
FS90-4L-C40	CAT 40	10.12 (257)	1.38 (35)	2.559 (65)	H=3.149 (80)	15 lbs (6.8 Kg)	Stop Block Wrenches Grease Instructions
FS90-4L-B40	BT 40	10.12 (257)	1.38 (35)	2.559 (65)	H=3.149 (80)	15 lbs (6.8 Kg)	
FS90-4L-C50	CAT 50	10.12 (257)	1.38 (35)	3.149 (80)		19.8 lbs (9 Kg)	
FS90-4L-H63	HSK63A	10.27 (261)	1.73 (44)	2.559 (65)	H=3.149 (80)	15 lbs (6.8 Kg)	
FS90-4L-H100	HSK100A	10.27 (261)	1.81 (46)	3.149 (80)		19.8 lbs (9 Kg)	
Other Shank Options available: C5, C6, C8 (ISO 26623) and KM 63							

Order ER11 Collets separately. See pages 47-51.



### F90-7

Anti-Rotation Interchangeability: TYPE 1 (See page 52)

Option type 2 and 3 anti-rotation available.

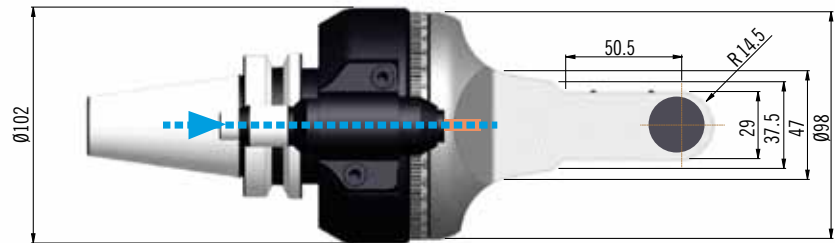
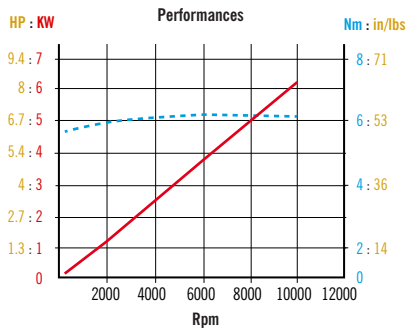
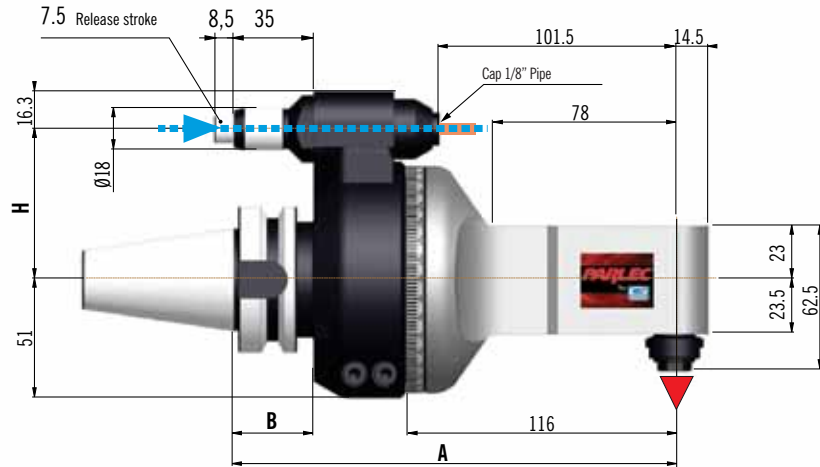

### APPLICATION SPECIFICATION

Output Shaft	Range	Ratio	RPM Max	Axial Load Max	Torque	Coolant	Direction
ER 11	.5- 7 mm	1:1	10,000	28lbs (127 N)	53 in/lbs (6 Nm)	Positioning Pin	Opposite Spindle
Optional Output Shaft: Double ER, Page 15 Additional Output Shafts available: Weldon			Optional coolant: Through Spindle from Pin, Page 15 Configured for optional internal air pressure				

### PRODUCT

Description	Shank	A	B	H	H Options	Weight	Spares Included
FS90-7-C40	CAT 40	7.48 (190)	1.38 (35)	2.559 (65)	H=3.149 (80)	11 lbs (5 Kg)	Stop Block Wrenches Grease Instructions
FS90-7-B40	BT 40	7.48 (190)	1.38 (35)	2.559 (65)	H=3.149 (80)	11 lbs (5 Kg)	
FS90-7-C50	CAT 50	7.48 (190)	1.38 (35)	3.149 (80)		15.4 lbs (7 Kg)	
FS90-7-H63	HSK63A	7.83 (199)	1.73 (44)	2.559 (65)	H=3.149 (80)	11 lbs (5 Kg)	
FS90-7-H100	HSK100A	7.83 (199)	1.81 (46)	3.149 (80)		15.4 lbs (7 Kg)	
Other Shank Options available: C5, C6, C8 (ISO 26623) and KM 63							

Order ER11 Collets separately. See pages 47-51.





### F90-7C With optional 150 PSI coolant piped through output shaft

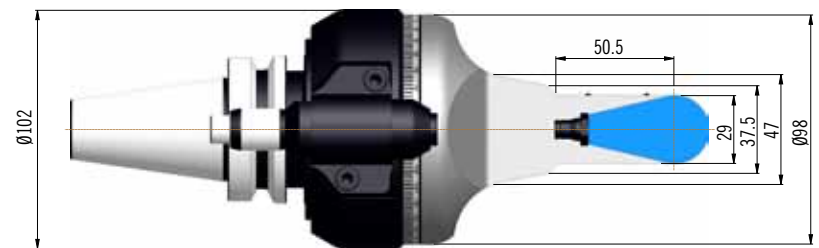
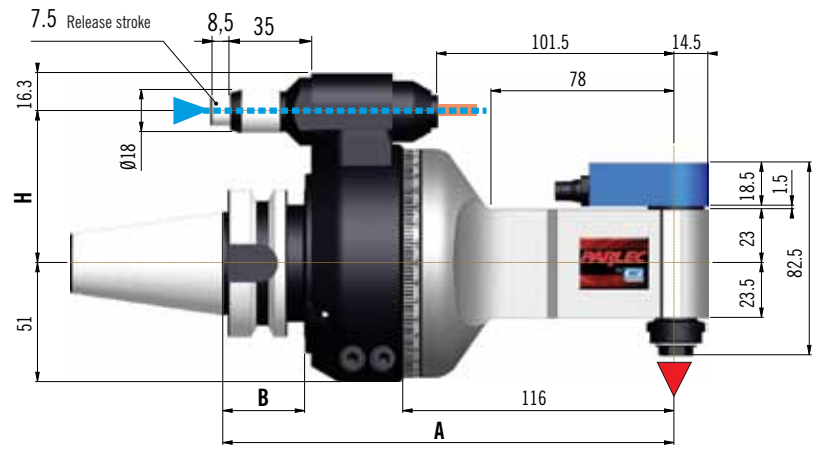
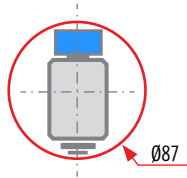

**DRY RUNNING NOT POSSIBLE**

### F90-7D With optional double output



Note: Coolant through Positioning Pin only

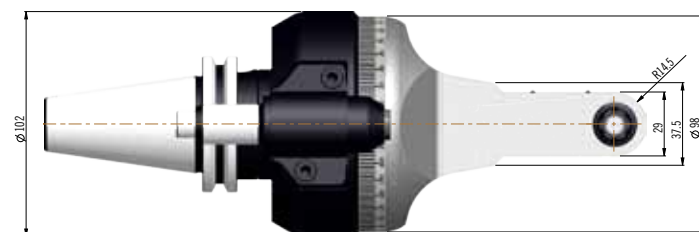
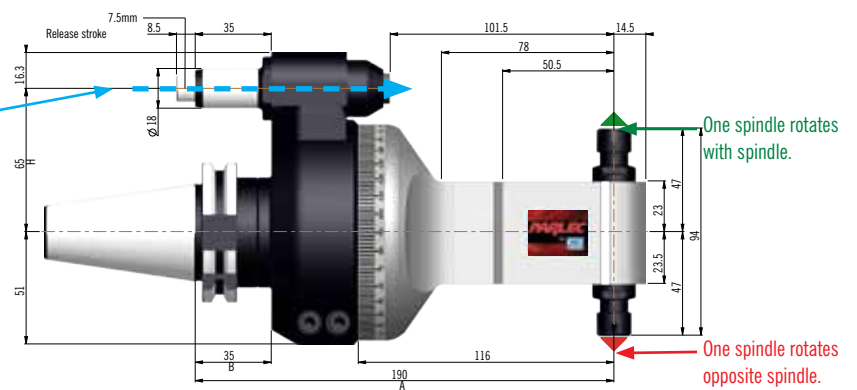



### F90-7L

Anti-Rotation Interchangeability: TYPE 1 (See page 52)

Option type 2 and 3 anti-rotation available.

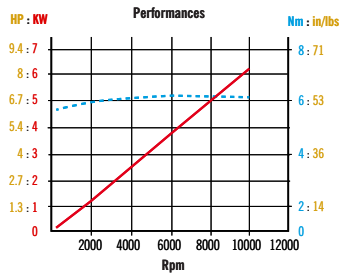
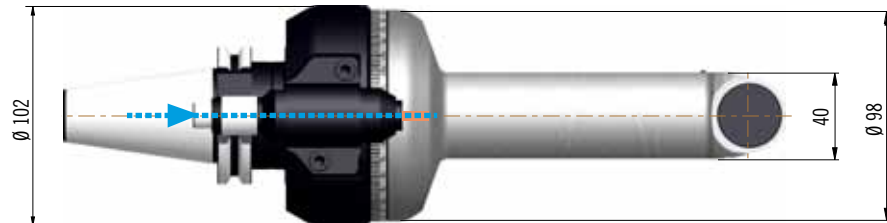
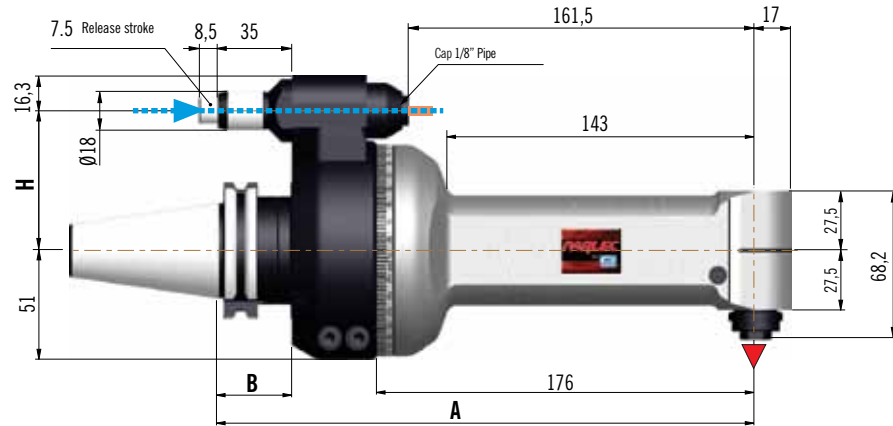
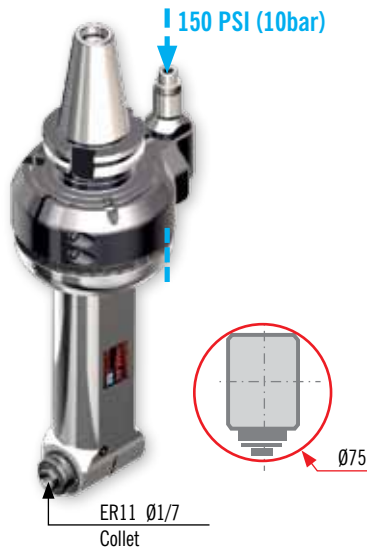

### APPLICATION SPECIFICATION

Output Shaft	Range	Ratio	RPM Max	Axial Load Max	Torque	Coolant	Direction
ER 11	.5- 7 mm	1:1	10,000	28lbs (127 N)	53 in/lbs (6 Nm)	Positioning Pin	Opposite Spindle
Optional Output Shaft: Double ER, Page 17 Additional Output Shafts available: Weldon			Optional coolant: Through Spindle from Pin, Page 17 Configured for optional internal air pressure				

### PRODUCT

Description	Shank	A	B	H	H Options	Weight	Spares Included
F90-7L-C40	CAT 40	9.84 (250)	1.38 (35)	2.559 (65)	H=3.149 (80)	13.8 lbs (6.3 Kg)	Stop Block Wrenches Grease Instructions
F90-7L-B40	BT 40	9.84 (250)	1.38 (35)	2.559 (65)	H=3.149 (80)	13.8 lbs (6.3 Kg)	
F90-7L-C50	CAT 50	9.84 (250)	1.38 (35)	3.149 (80)		18.7 lbs (8.5 Kg)	
F90-7L-H63	HSK63A	10.20 (259)	1.73 (44)	2.559 (65)	H=3.149 (80)	13.8 lbs (6.3 Kg)	
F90-7L-H100	HSK100A	10.20 (259)	1.81 (46)	3.149 (80)		18.7 lbs (8.5 Kg)	
Other Shank Options available: C5, C6, C8 (ISO 26623) and KM 63							

Order ER11 Collets separately. See pages 47-51.



### F90-7LC With optional 150 PSI coolant piped through output shaft

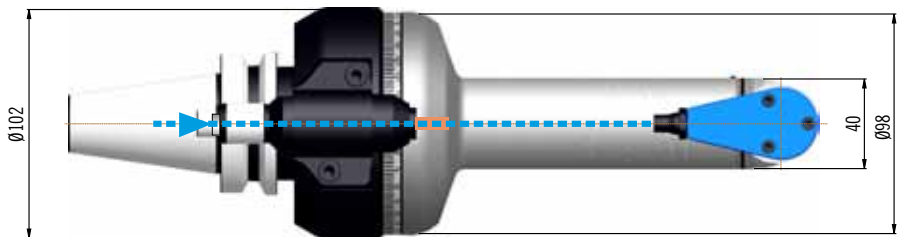
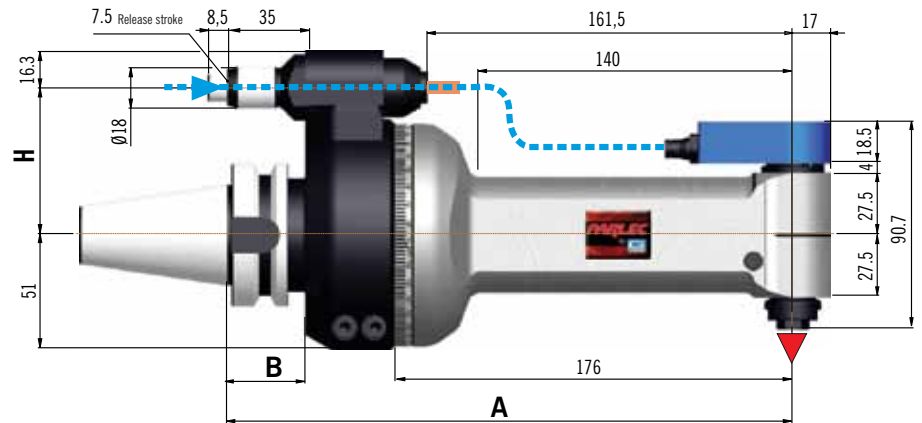
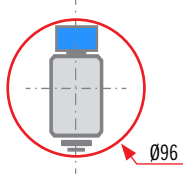

**DRY RUNNING NOT POSSIBLE**

### F90-7LD With optional double output

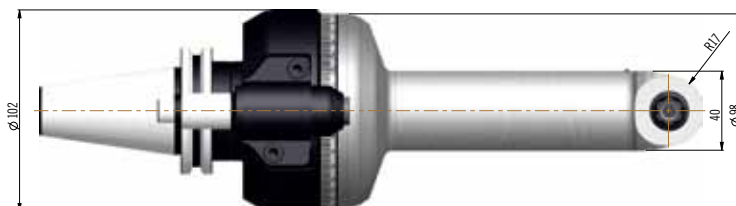
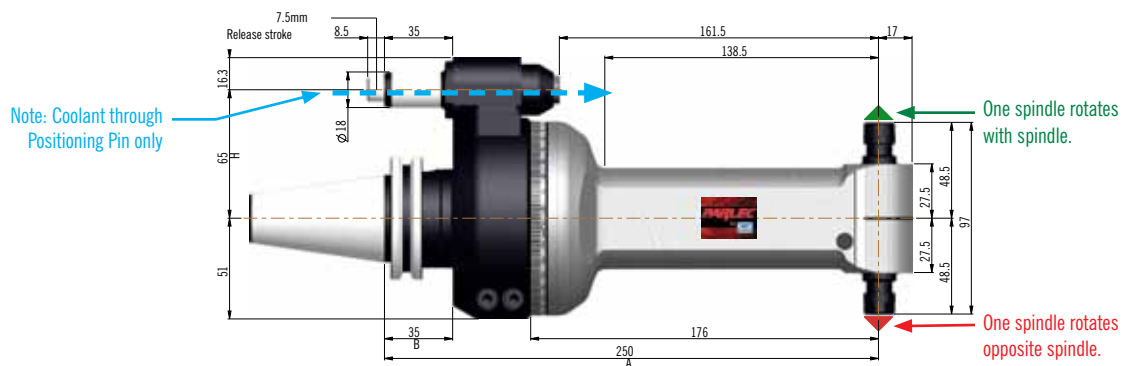





### F90-10

Anti-Rotation Interchangeability: TYPE 1 (See page 52)

Option type 2 and 3 anti-rotation available.

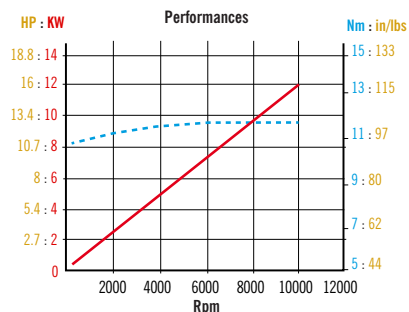
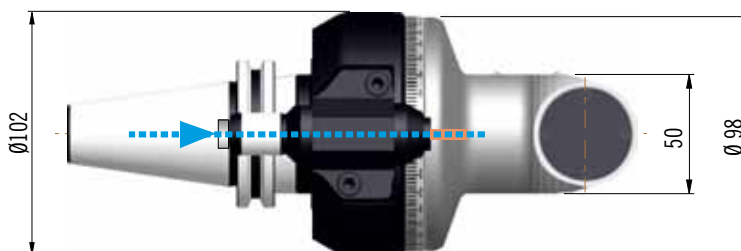
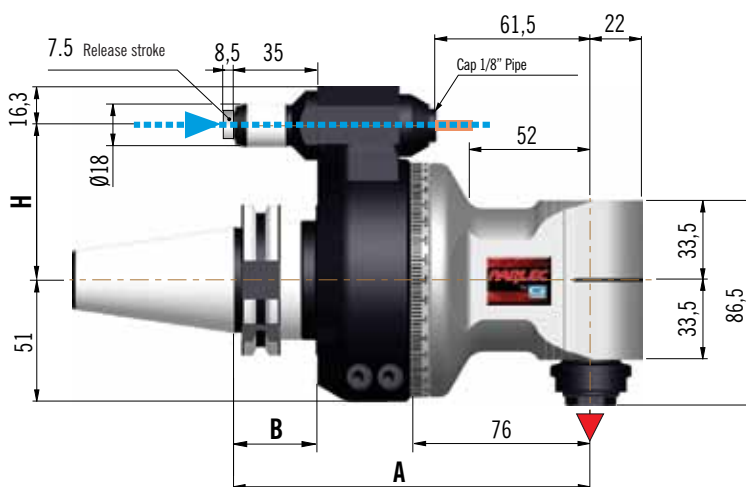
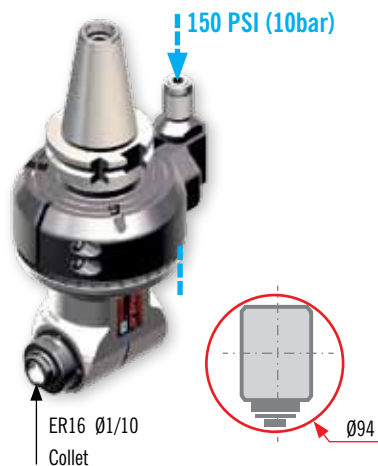

### APPLICATION SPECIFICATION

Output Shaft	Range	Ratio	RPM Max	Axial Load Max	Torque	Coolant	Direction
ER 16	1-10 mm	1:1	10,000	90lbs (400 N)	97 in/lbs (11 Nm)	Positioning Pin	Opposite Spindle
Optional Output Shaft: Weldon and Double ER, Page 19 Additional Output Shafts available: Weldon, Shell Mill			Optional coolant: Through Spindle from Pin, Page 19 Configured for optional internal air pressure				

### PRODUCT

Description	Shank	A	B	H	H Options	Weight	Spares Included
F90-10-C40	CAT 40	5.90 (150)	1.38 (35)	2.559 (65)	H=3.149 (80)	11.7 lbs (5.3 Kg)	Stop Block Wrenches Grease Instructions
F90-10-B40	BT 40	5.90 (150)	1.38 (35)	2.559 (65)	H=3.149 (80)	11.7 lbs (5.3 Kg)	
F90-10-C50	CAT 50	5.90 (150)	1.38 (35)	3.149 (80)		16.5 lbs (7.5 Kg)	
F90-10-H63	HSK63A	6.26 (159)	1.73 (44)	2.559 (65)	H=3.149 (80)	11.7 lbs (5.3 Kg)	
F90-10-H100	HSK100A	6.26 (159)	1.81 (46)	3.149 (80)		16.5 lbs (7.5 Kg)	
Other Shank Options available: C5, C6, C8 (ISO 26623) and KM 63							

Order ER16 Collets separately. See pages 47-51.



**F90-10C** With optional 150 PSI coolant piped through output shaft

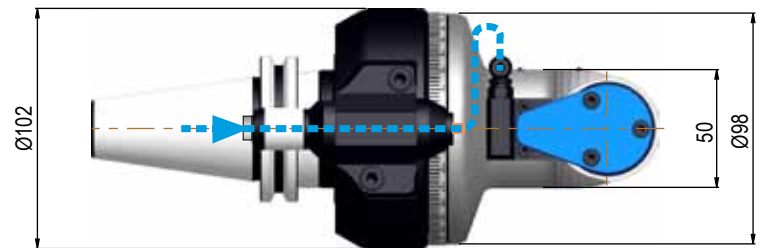
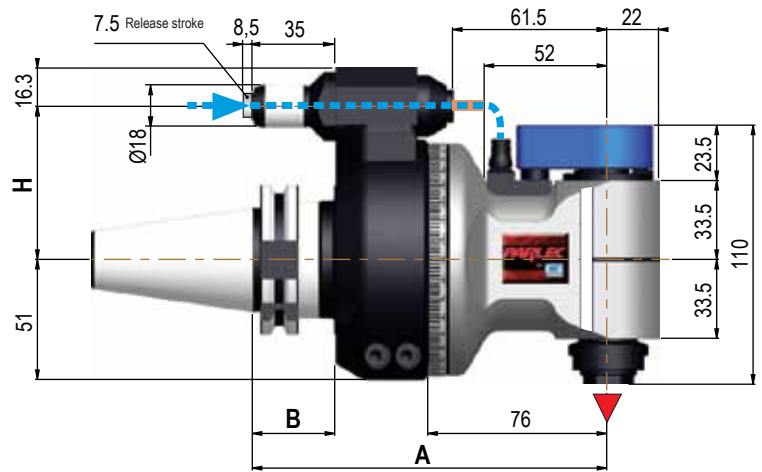
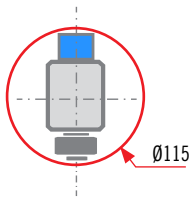

**DRY RUNNING NOT POSSIBLE**

**F90-10D** With optional double output

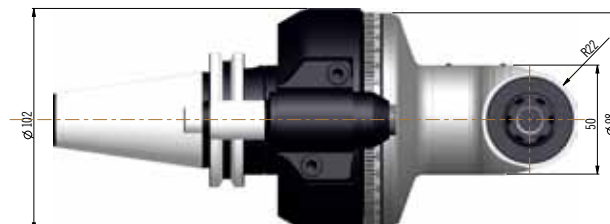
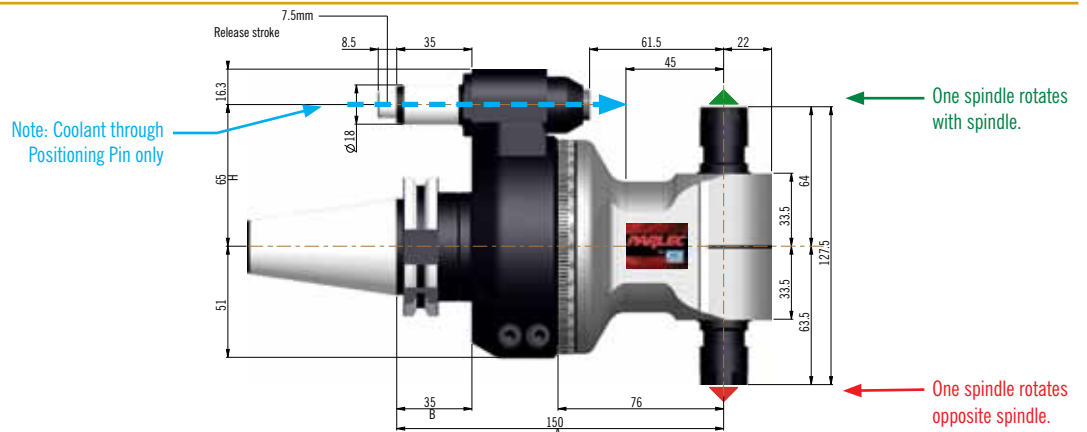



### F90-10L

Anti-Rotation Interchangeability: **TYPE 1** (See page 52)

Option type 2 and 3 anti-rotation available.

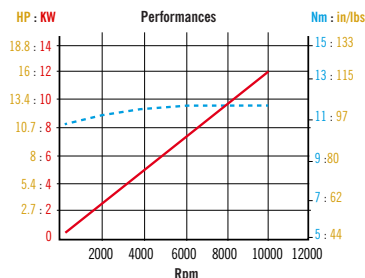
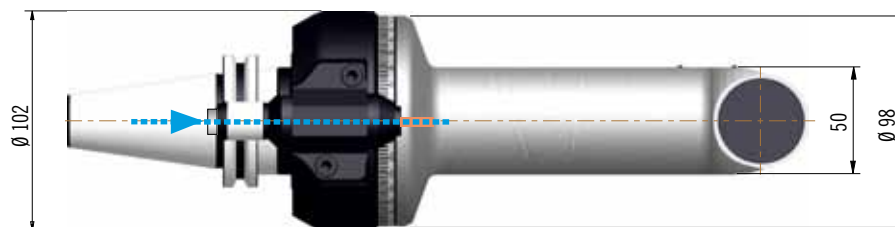
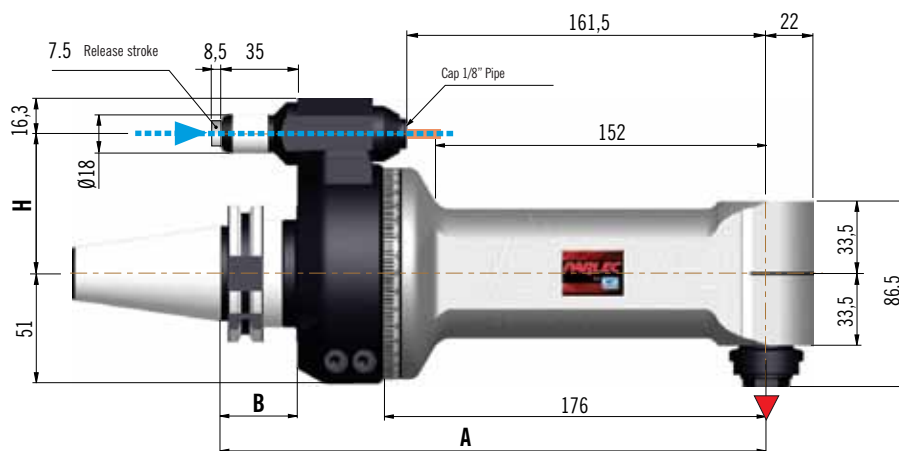
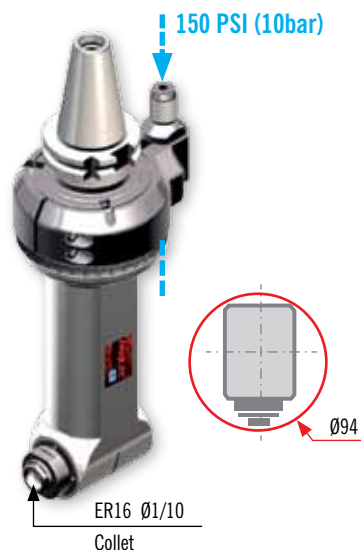

### APPLICATION SPECIFICATION

Output Shaft	Range	Ratio	RPM Max	Axial Load Max	Torque	Coolant	Direction
ER 16	1-10 mm	1:1	10,000	90lbs (400 N)	97 in/lbs (11 Nm)	Positioning Pin	Opposite Spindle
Optional Output Shaft: Double ER, Page 21 Additional Output Shafts available: Weldon, Shell Mill			Optional coolant: Through Spindle from Pin, Page 21 Configured for optional internal air pressure				

### PRODUCT

Description	Shank	A	B	H	H Options	Weight	Spares Included
F90-10L-C40	CAT 40	9.84 (250)	1.38 (35)	2.559 (65)	H=3.149 (80)	15.2 lbs (6.9 Kg)	Stop Block Wrenches Grease Instructions
F90-10L-B40	BT 40	9.84 (250)	1.38 (35)	2.559 (65)	H=3.149 (80)	15.2 lbs (6.9 Kg)	
F90-10L-C50	CAT 50	9.84 (250)	1.38 (35)	3.149 (80)		20.2 lbs (9.2 Kg)	
F90-10L-H63	HSK63A	10.20 (259)	1.73 (44)	2.559 (65)	H=3.149 (80)	15.2 lbs (6.9 Kg)	
F90-10L-H100	HSK100A	10.20 (259)	1.81 (46)	3.149 (80)		20.2 lbs (9.2 Kg)	
Other Shank Options available: C5, C6, C8 (ISO 26623) and KM 63							

Order ER16 Collets separately. See pages 47-51.



### F90-10LC With optional 150 PSI coolant piped through output shaft

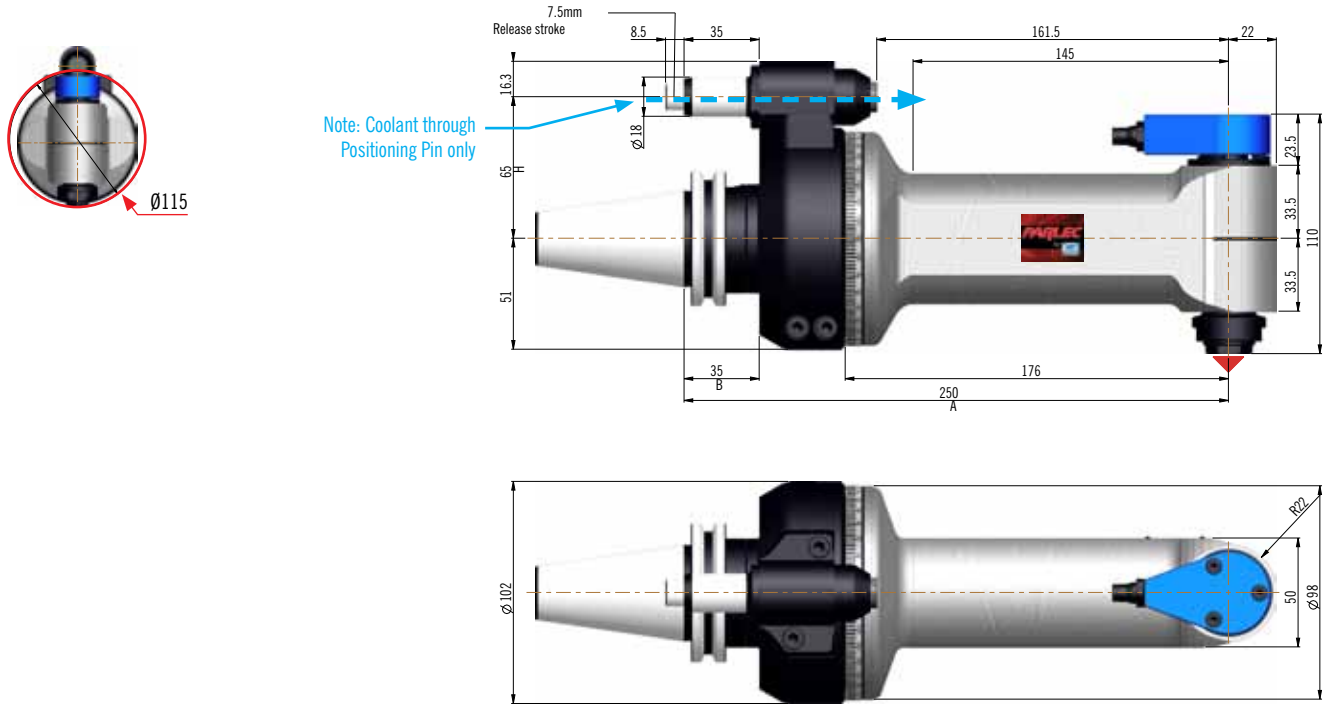

**DRY RUNNING NOT POSSIBLE**

### F90-10LD With optional double output

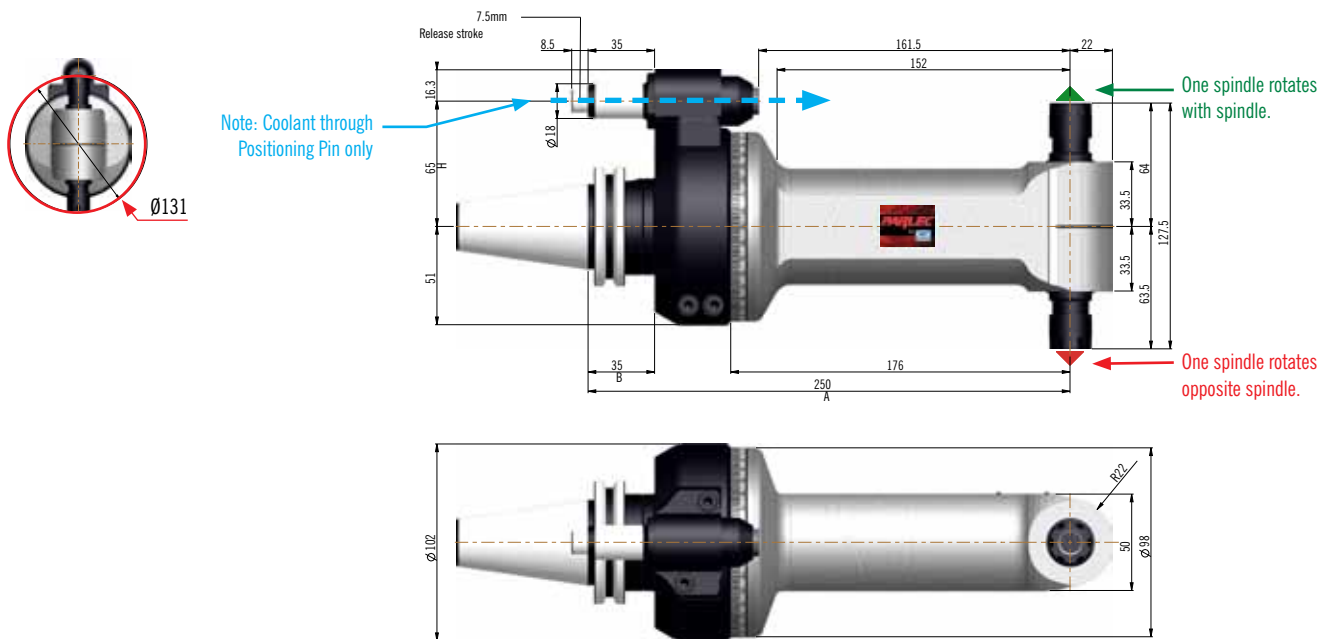





### F90-16S

Anti-Rotation Interchangeability: **TYPE 1** (See page 52)

Option type 2 and 3 anti-rotation available.

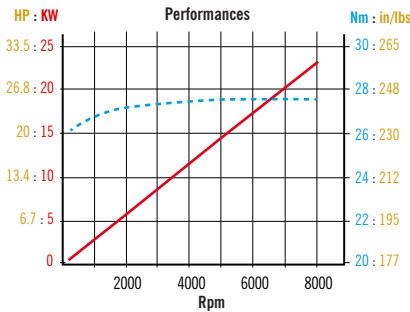
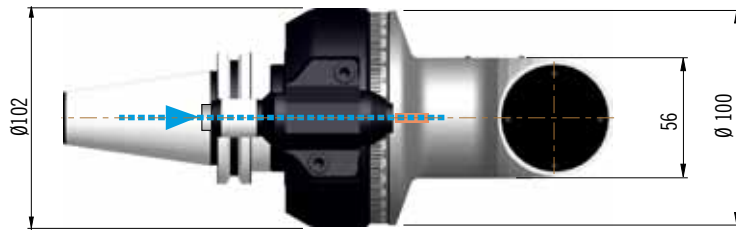
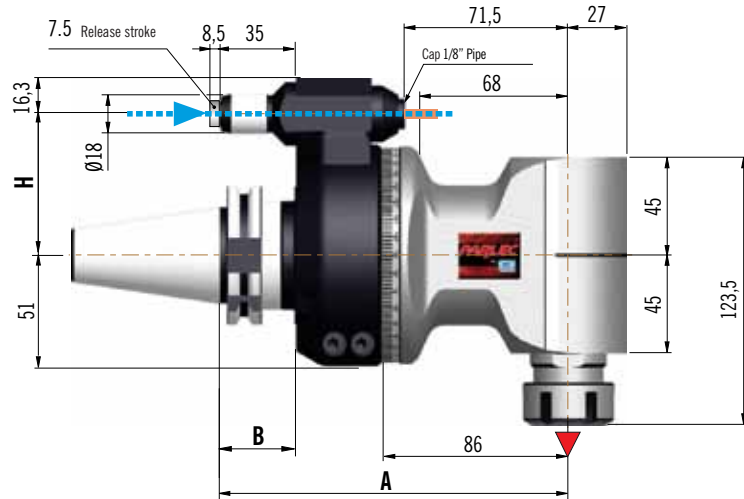
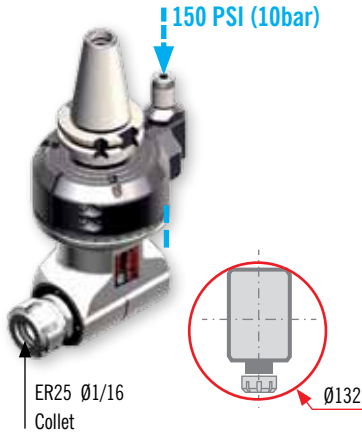

Reduced performances with shank size C5

### APPLICATION SPECIFICATION

Output Shaft	Range	Ratio	RPM Max	Axial Load Max	Torque	Coolant	Direction
ER 25	1-16 mm	1:1	8,000	182lbs (810 N)	239 in/lbs (27 Nm)	Positioning Pin	Opposite Spindle
Optional Output Shaft: Double ER, Page 23 Additional Output Shafts available: Weldon, Shell Mill, HSK32A			Optional coolant: Through Spindle from Pin, Page 23 Configured for optional internal air pressure				

### PRODUCT

Description	Shank	A	B	H	H Options	Weight	Spares Included
F90-16S-C40	CAT 40	6.30 (160)	1.38 (35)	2.559 (65)	H=3.149 (80)	14 lbs (6.4 Kg)	Stop Block Wrenches Grease Instructions
F90-16S-B40	BT 40	6.30 (160)	1.38 (35)	2.559 (65)	H=3.149 (80)	14 lbs (6.4 Kg)	
F90-16S-C50	CAT 50	6.30 (160)	1.38 (35)	3.149 (80)		19.1 lbs (8.7 Kg)	
F90-16S-H63	HSK63A	6.65 (169)	1.73 (44)	2.559 (65)	H=3.149 (80)	14 lbs (6.4 Kg)	
F90-16S-H100	HSK100A	6.65 (169)	1.81 (46)	3.149 (80)		19.1 lbs (8.7 Kg)	
Other Shank Options available: C5, C6, C8 (ISO 26623) and KM 63							

Order ER25 Collets separately. See pages 47-51.



**F90-16SC** With optional 150 PSI coolant piped through output shaft

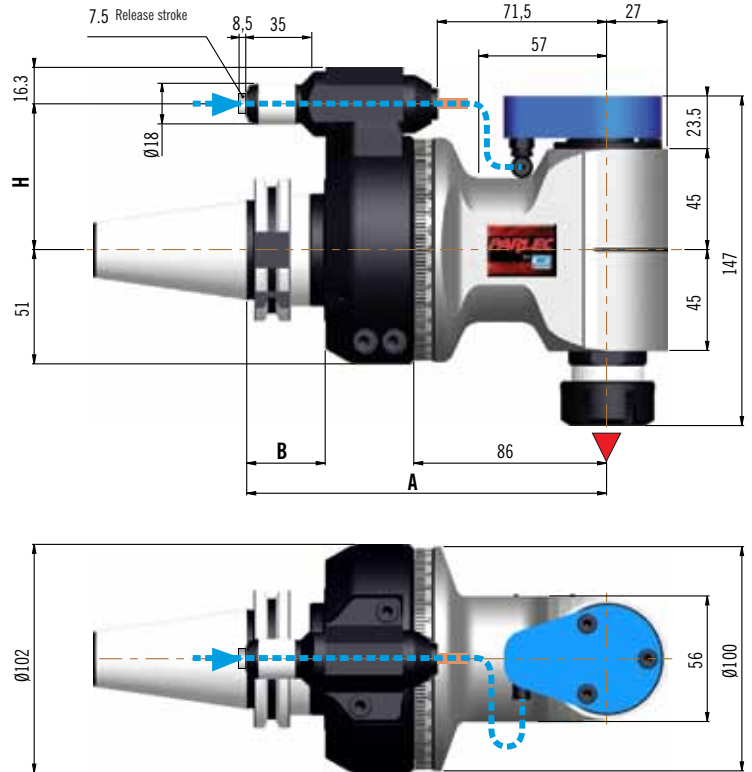
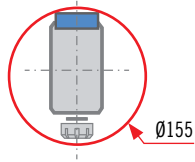

**DRY RUNNING NOT POSSIBLE**

**F90-16SD** With optional double output

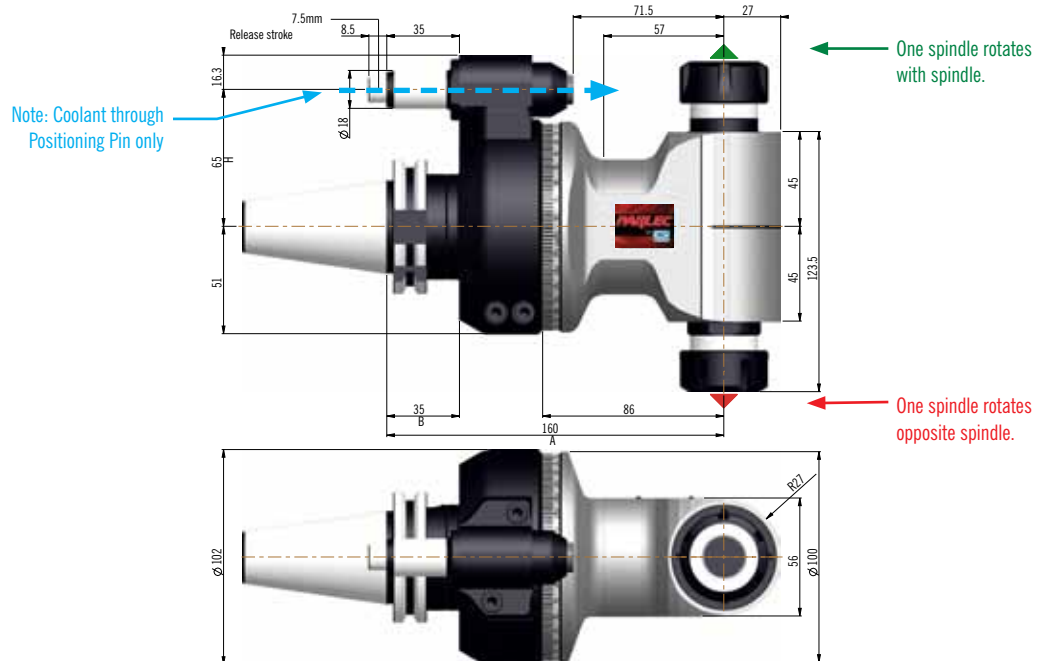
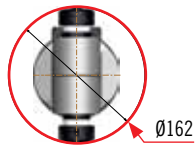



## F90-16

Anti-Rotation Interchangeability: **TYPE 2** (See page 52)

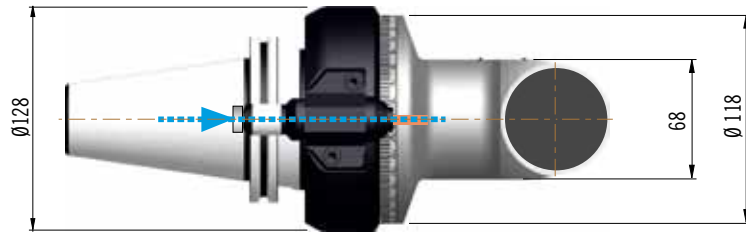
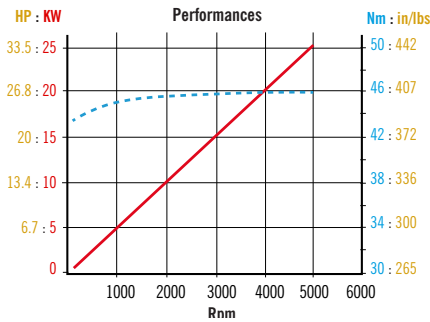
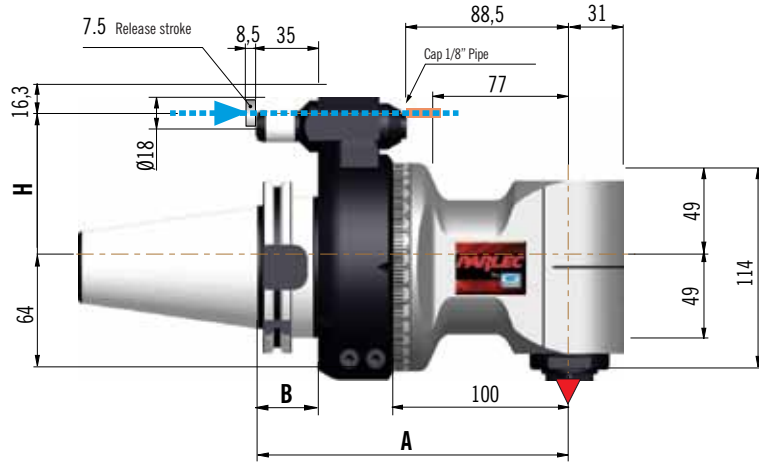
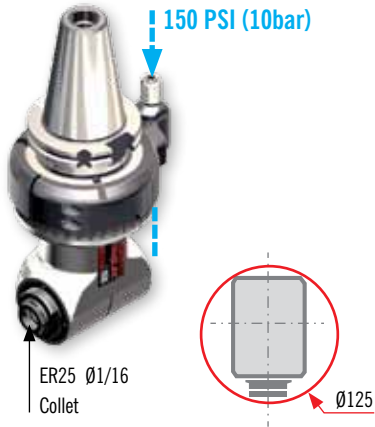

### APPLICATION SPECIFICATION

Output Shaft	Range	Ratio	RPM Max	Axial Load Max	Torque	Coolant	Direction
ER 25	1-16mm	1:1	5,000	182lbs (810 N)	407 in/lbs (46 Nm)	Positioning Pin	Opposite Spindle
Optional Output Shaft: Double ER, Page 25 Additional Output Shafts available: Weldon, Shell Mill, HSK32A			Optional coolant: Through Spindle from Pin, Page 25 Configured for optional internal air pressure				

### PRODUCT

Description	Shank	A	B	H	H Options	Weight	Spares Included
F90-16-C50	CAT 50	6.97 (177)	1.38 (35)	3.149 (80)	4.33 (110)	24 lbs (11 Kg)	Stop Block Wrenches Grease Instructions
F90-16-H100	HSK100A	7.32 (186)	1.81 (46)	3.149 (80)	4.33 (110)	24 lbs (11 Kg)	
F90-16-CTP8	C8 (ISO 26623)	7.13 (181)		3.149 (80)	4.33 (110)	24 lbs (11 Kg)	
Other Shank Options available: BT 50 , HSK 80, KM 80, and 100							

Order ER25 Collets separately. See pages 47-51.



**F90-16C** With optional 150 PSI coolant piped through output shaft

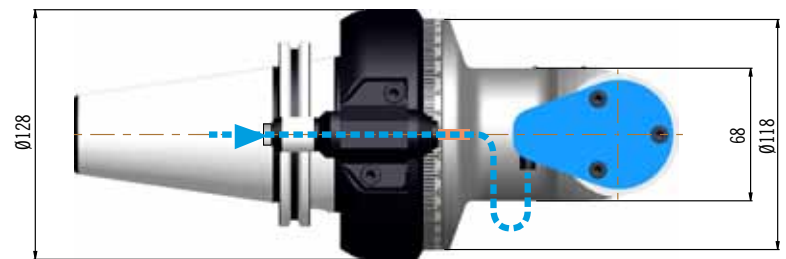
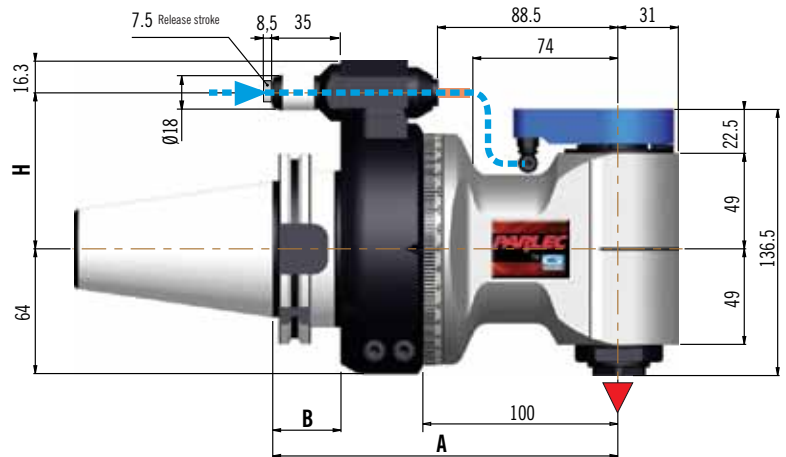
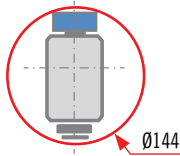

**DRY RUNNING NOT POSSIBLE**

**F90-16D** With optional double output

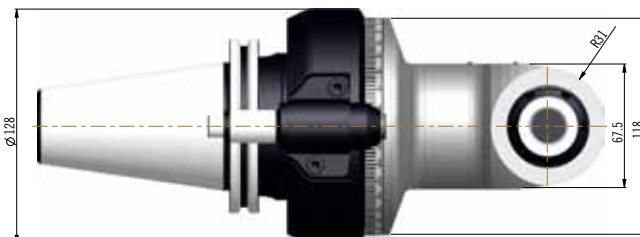
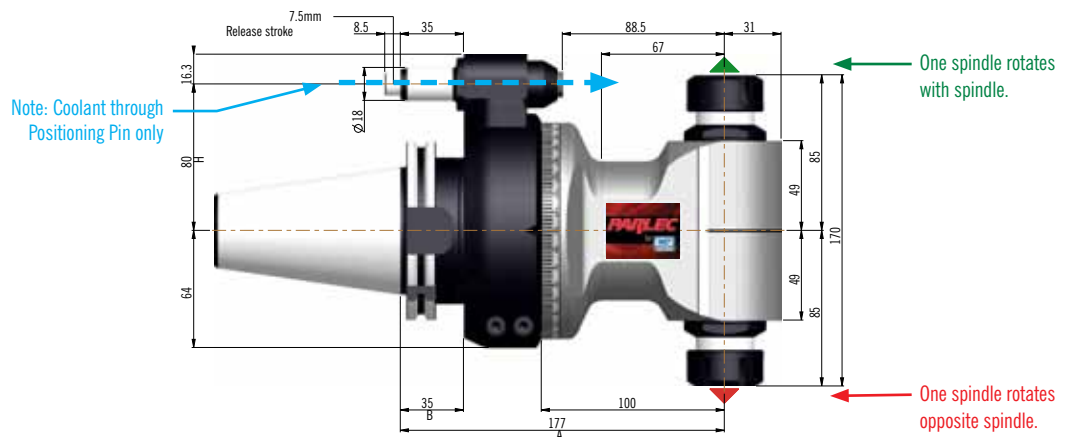





## F90-16L

Anti-Rotation Interchangeability: **TYPE 2** (See page 52)

Option type 3 anti-rotation available.

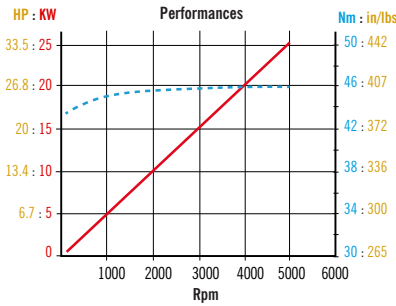
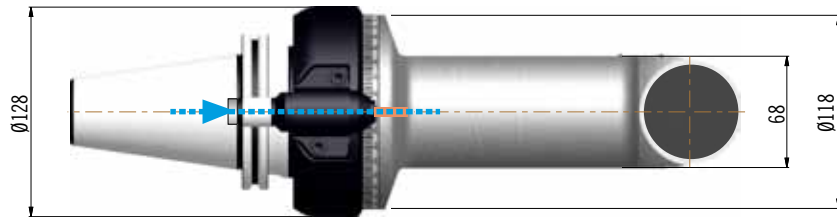
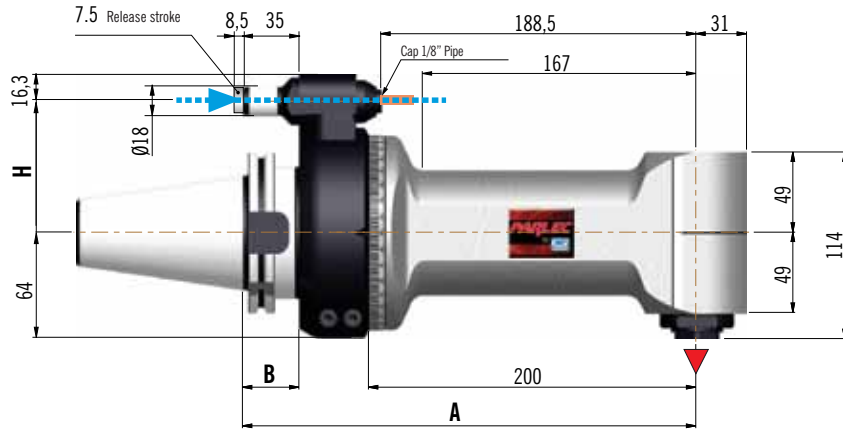

### APPLICATION SPECIFICATION

Output Shaft	Range	Ratio	RPM Max	Axial Load Max	Torque	Coolant	Direction
ER25	1-16mm	1:1	8,000	182lbs (810 N)	407 in/lbs (46 Nm)	Positioning Pin	Opposite Spindle
Optional Output Shaft: Double ER, Page 27 Additional Output Shafts available: Weldon, Shell Mill, HSK32A			Optional coolant: Through Spindle from Pin, Page 27 Configured for optional internal air pressure.				

### PRODUCT

Description	Shank	A	B	H	H Options	Weight	Spares Included
F90-16L-C50	CAT 50	10.90 (277)	1.38 (35)	3.149 (80)	4.33 (110)	28 lbs (12.7 Kg)	Stop Block Wrenches Grease Instructions
F90-16L-H100	HSK100A	11.26 (286)	1.81 (46)	3.149 (80)	4.33 (110)	28 lbs (12.7 Kg)	
F90-16L-CTP8	C8 (ISO 26623)	11.07 (281)		3.149 (80)	4.33 (110)	28 lbs (12.7 Kg)	
Other Shank Options available: BT 50, HSK 80, KM 80 and 100							

Order ER25 Collets separately. See pages 47-51.



### F90-16LC With optional 150 PSI coolant piped through output shaft

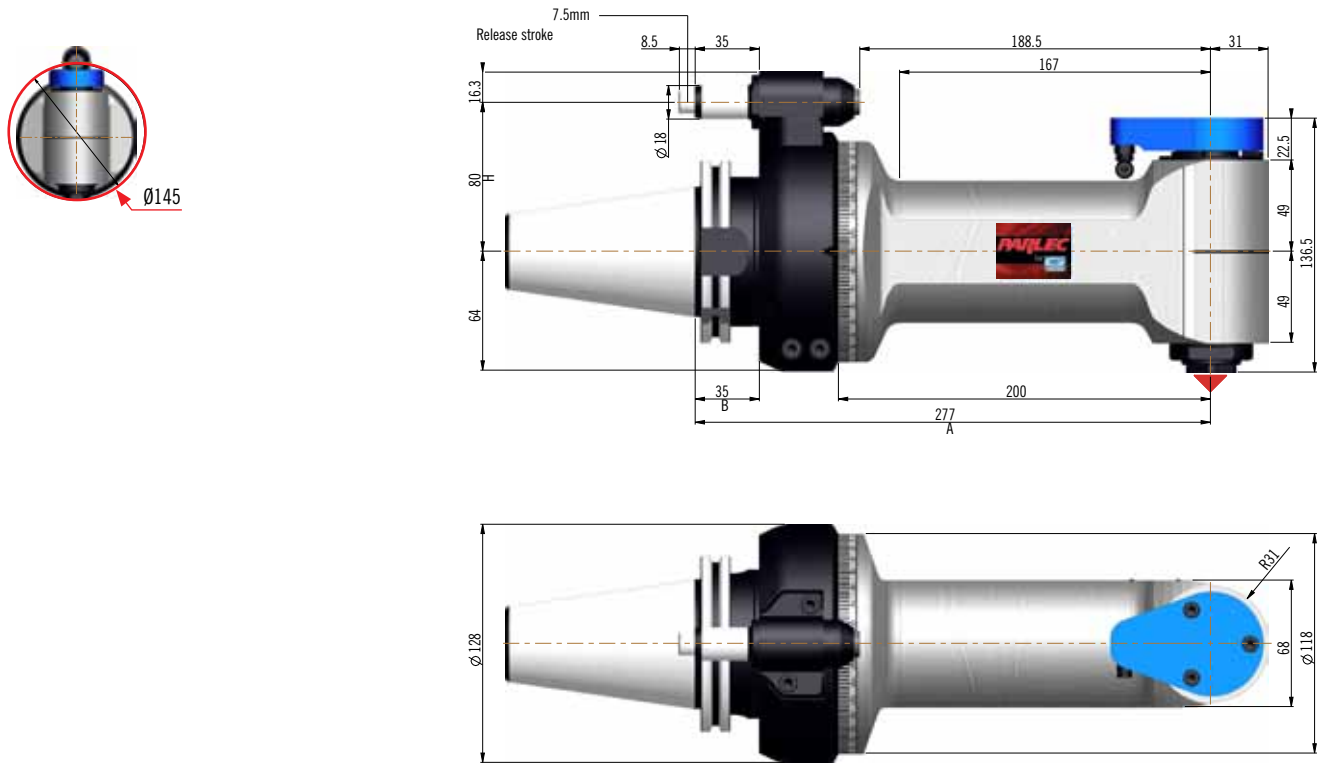

**DRY RUNNING NOT POSSIBLE**

### F90-16LD With optional double output

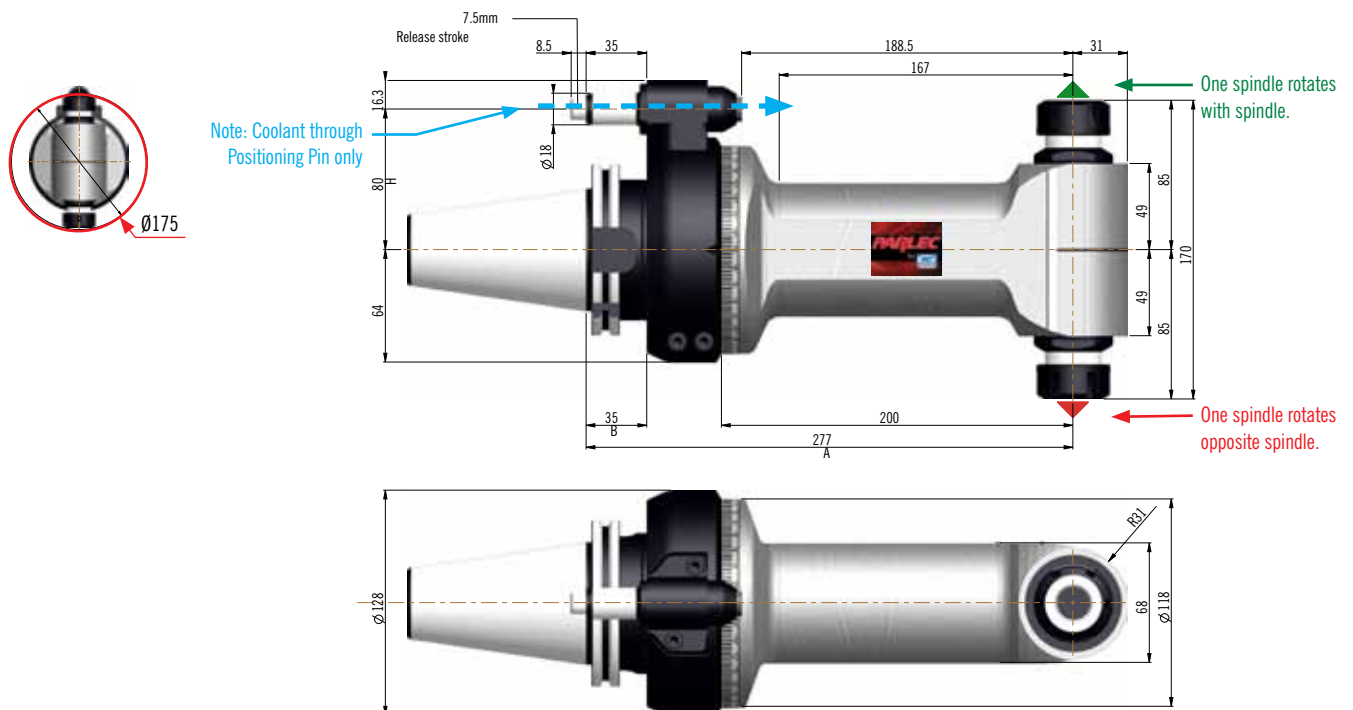



### F90-20

Anti-Rotation Interchangeability: **TYPE 2** (See page 52)

Option type 3 anti-rotation available.

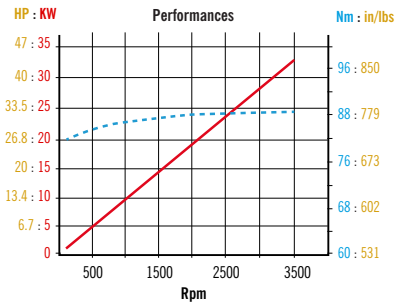
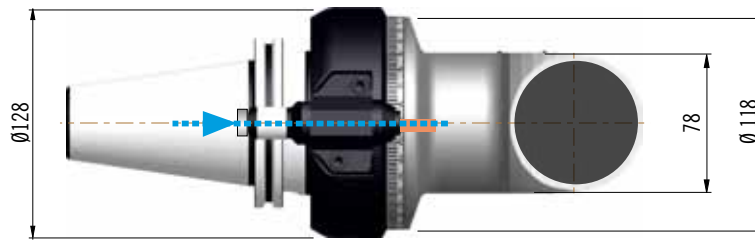
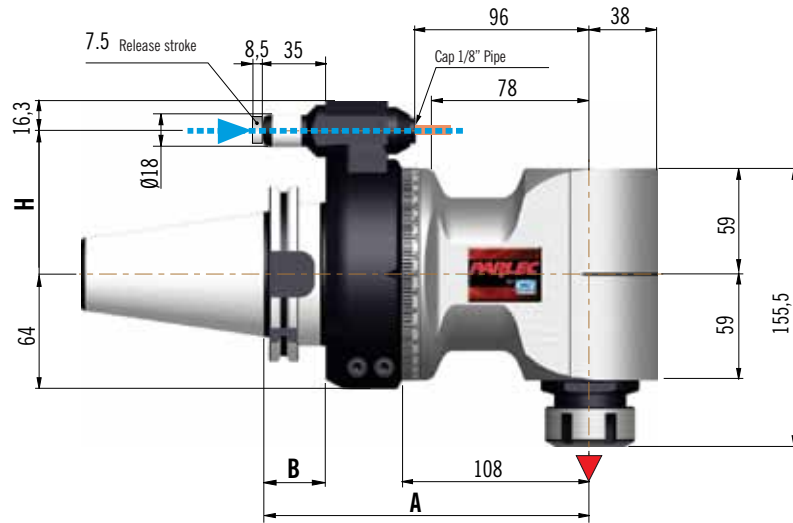
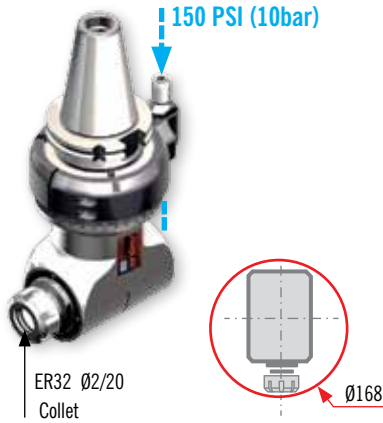

### APPLICATION SPECIFICATION

Output Shaft	Range	Ratio	RPM Max	Axial Load Max	Torque	Coolant	Direction
ER 32	1-20 mm	1:1	3,500	328lbs (1460 N)	752 in/lbs (85 Nm)	Positioning Pin	Opposite Spindle
Optional Output Shaft: Double ER, Page 29 Additional Output Shafts available: Weldon, HSK40A, Cpt4			Optional coolant: Through Spindle from Pin, Page 29 Configured for optional internal air pressure				

### PRODUCT

Description	Shank	A	B	H	H Options	Weight	Spares Included
F90-16L-C50	CAT 50	10.90 (277)	1.38 (35)	3.149 (80)	4.33 (110)	28 lbs (12.7 Kg)	Stop Block
F90-16L-H100	HSK100A	11.26 (286)	1.81 (46)	3.149 (80)	4.33 (110)	28 lbs (12.7 Kg)	Wrenches
F90-16L-CTP8	C8 (ISO 26623)	11.07 (281)		3.149 (80)	4.33 (110)	28 lbs (12.7 Kg)	Grease Instructions
Other Shank Options available: BT 50 , HSK 80, KM 80 and 100							

Order ER32 Collets separately. See pages 47-51.



**F90-20C** With optional 150 PSI coolant piped through output shaft

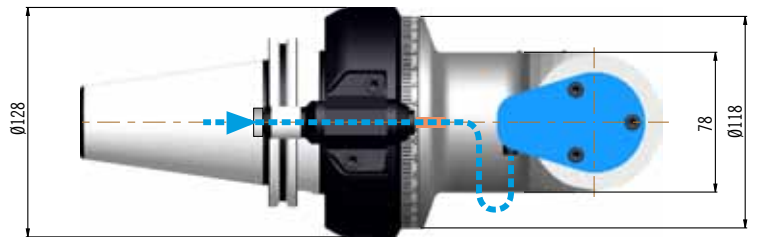
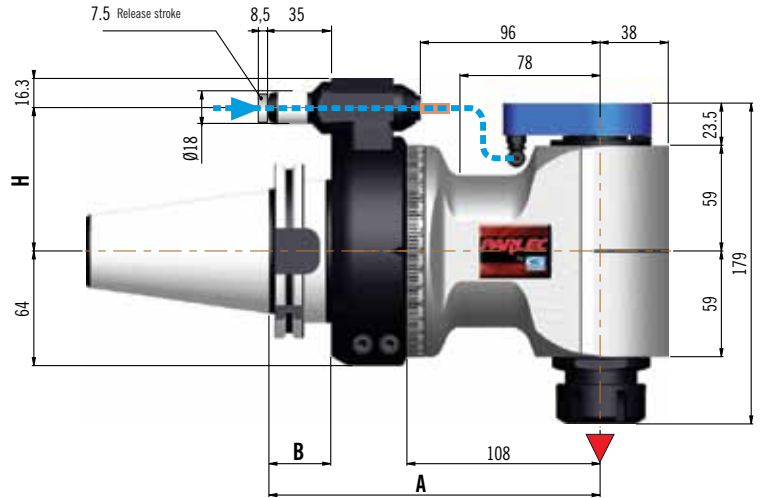
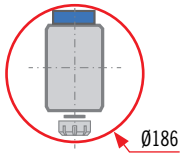

**DRY RUNNING NOT POSSIBLE**

**F90-20D** With optional double output

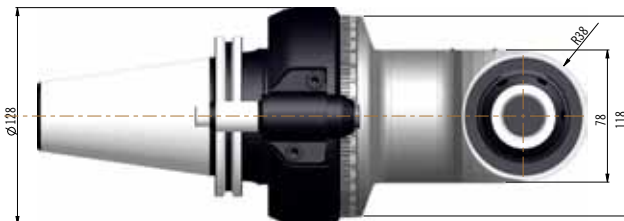
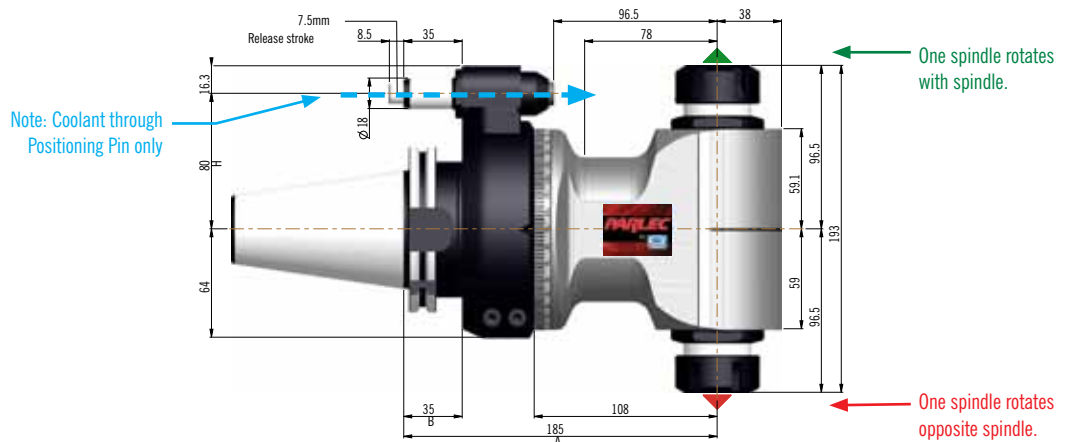
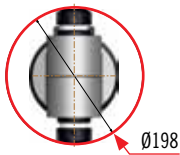





## F90-S40

Anti-Rotation Interchangeability: **TYPE 3** (See page 52)

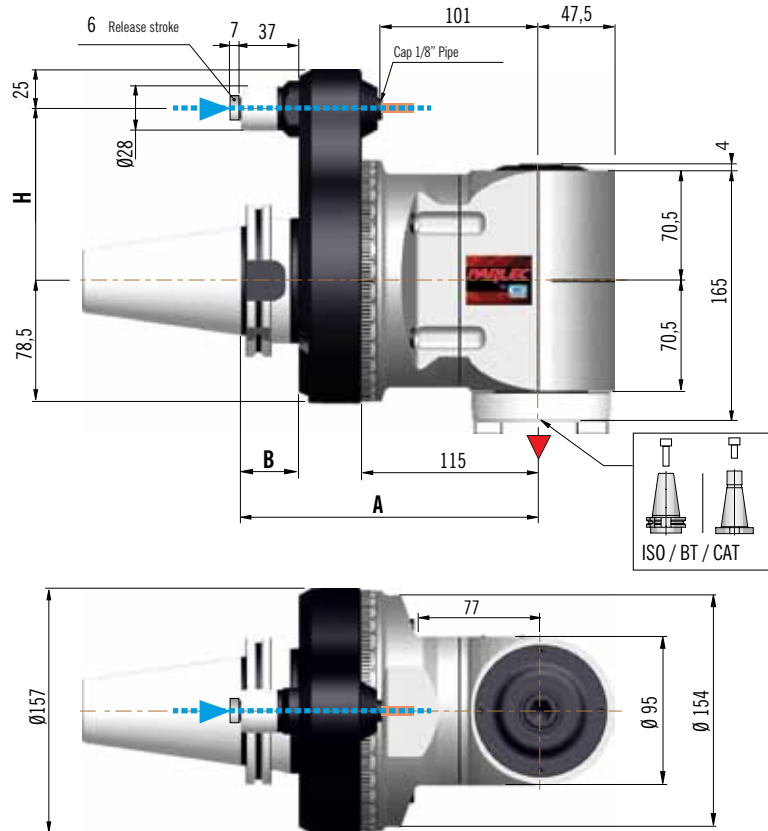
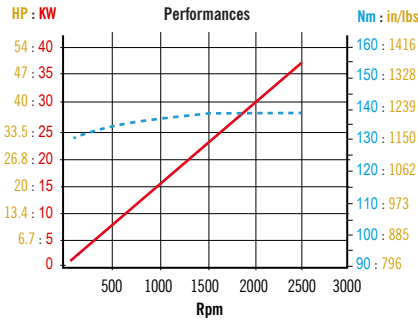

### APPLICATION SPECIFICATION

Output Shaft	Range	Ratio	RPM Max	Axial Load Max	Torque	Coolant	Direction
ISO 40		1:1	2,500	680lbs (3020 N)	1196 in/lbs (135 Nm)	Positioning Pin	Opposite Spindle
Optional Output Shaft: Double ER, page 31. Additional Output Shafts available: Weldon, HSK40A, Cpt4			Optional coolant: Through Spindle from Pin, Page 31 Configured for optional internal air pressure				

### PRODUCT

Description	Shank	A	B	H	H Options	Weight	Spares Included
F90-S40-C50	CAT 50	7.56 (192)	1.46 (37)	4.33 (110)		48 lbs (21.7 Kg)	Stop Block
F90-S40-H100	HSK100A	7.91 (201)	1.89 (48)	4.33 (110)		48 lbs (21.7 Kg)	Wrenches
F90-S40-CTP8	C8 (ISO 26623)	7.72 (196)		4.33 (110)		48 lbs (21.7 Kg)	Grease
Instructions							
Other Shank Options available: BT 50 , HSK 80, KM 80 and 100							



### F90-S40C With optional 150 PSI coolant piped through output shaft

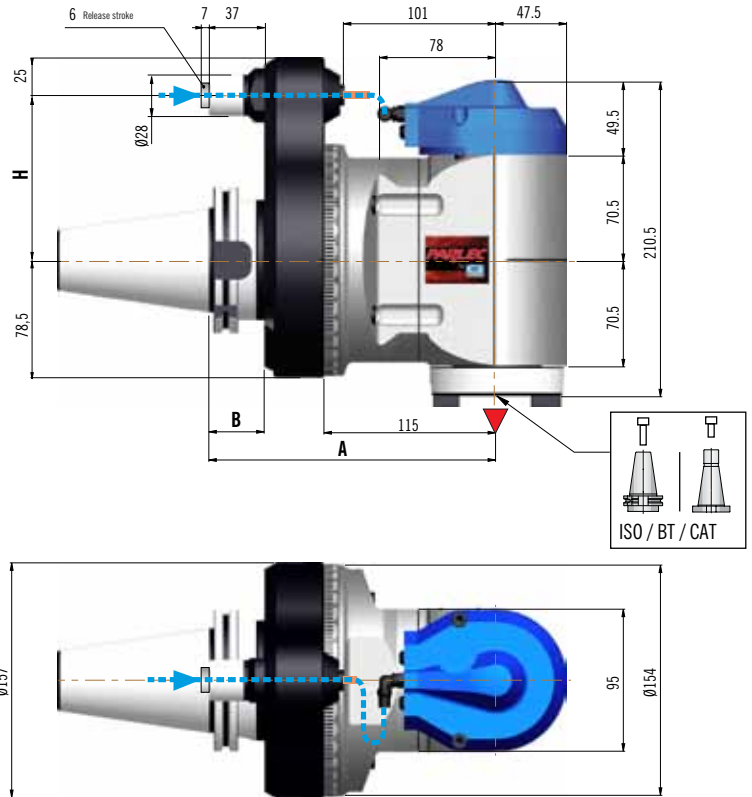
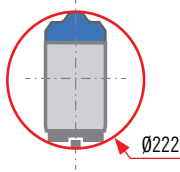

**DRY RUNNING NOT POSSIBLE**

### F90-30D With optional double output

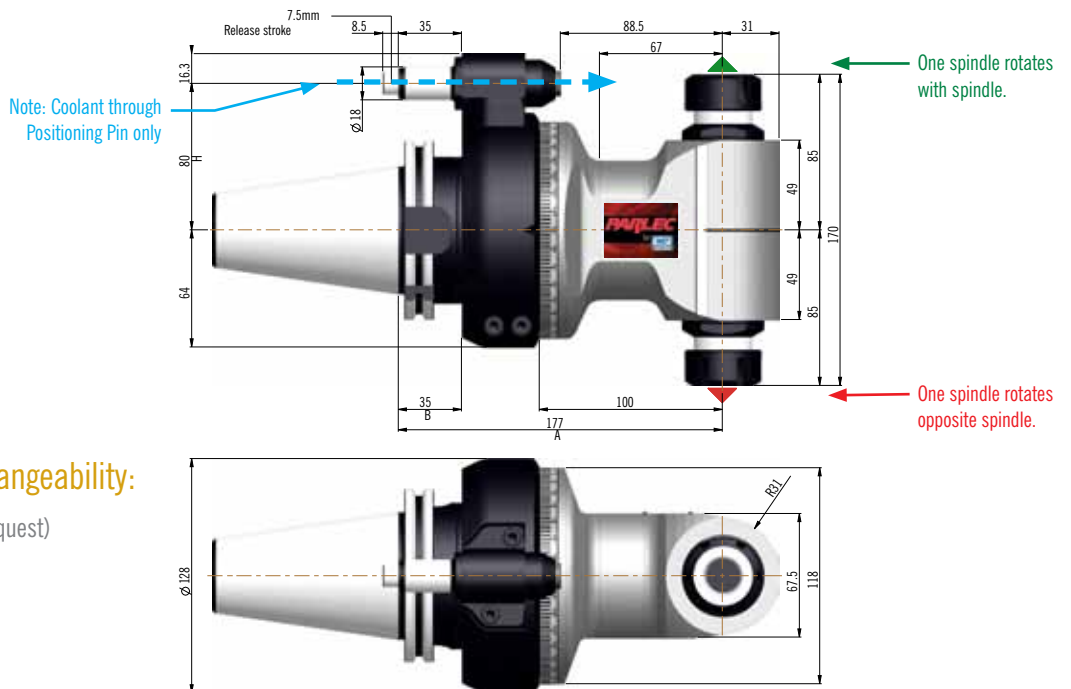

Output Shafts:  
ER40 : ER40

Anti-Rotation Interchangeability:  
**TYPE 2** (Available upon request)



## FR90-10

Anti-Rotation Interchangeability: **TYPE 1** (See page 52)

Option type 2 and 3 anti-rotation available.

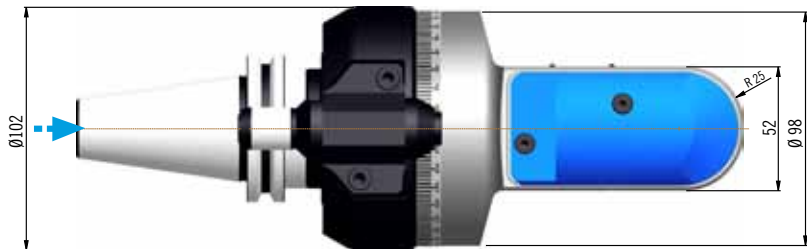
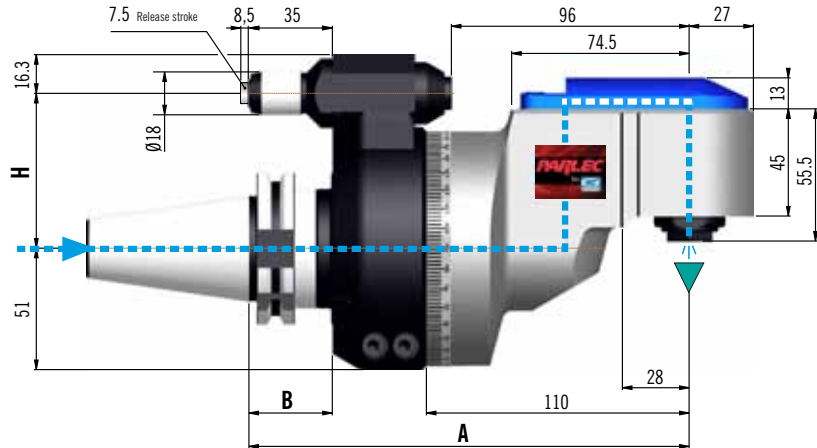
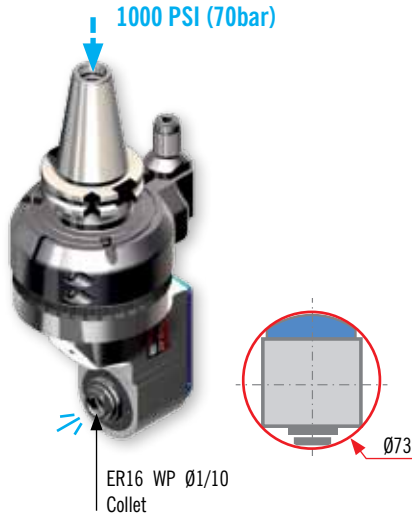

**DRY RUNNING NOT POSSIBLE**

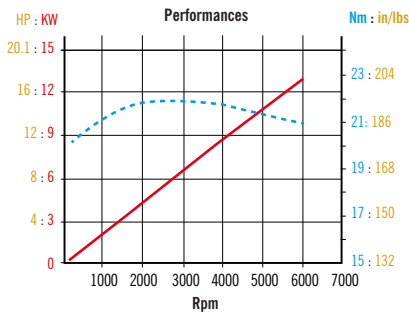

### APPLICATION SPECIFICATION

Output Shaft	Range	Ratio	RPM Max	Axial Load Max	Torque	Coolant	Direction
ER 16	1 - 10 mm	1:1	6,000	112lbs (500 N)	194 in/lbs (22 Nm)	1000 PSI (70 Bar)	Same As Spindle
Optional Output Shaft: Weldon						Through the Spindle	

### PRODUCT

Description	Shank	A	B	H	H Options	Weight	Spares Included
FR90-10-C40	CAT 40	7.26 (184.5)	1.38 (35)	2.559 (65)	H=3.149 (80)	13.6 lbs (6.2 Kg)	Stop Block Wrenches Grease Instructions
FR90-10-B40	BT 40	7.26 (184.5)	1.38 (35)	2.559 (65)	H=3.149 (80)	13.6 lbs (6.2 Kg)	
FR90-10-C50	CAT 50	7.26 (184.5)	1.38 (35)	3.149 (80)		19.1 lbs (8.7 Kg)	
FR90-10-H63	HSK63A	7.62 (193.5)	1.73 (44)	2.559 (65)	H=3.149 (80)	13.6 lbs (6.2 Kg)	
FR90-10-H100	HSK100A	7.62 (193.5)	1.81 (46)	3.149 (80)		19.1 lbs (8.7 Kg)	
Other Shank Options available: C5, C6, C8 (ISO 26623) and KM 63							

Order ER16 Collets separately. See pages 47-51.



FR90-16

Anti-Rotation Interchangeability: **TYPE 2** (See page 52)

Option type 3 anti-rotation available.

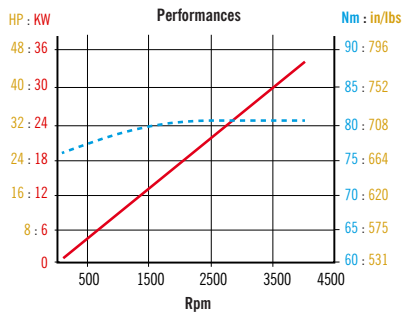
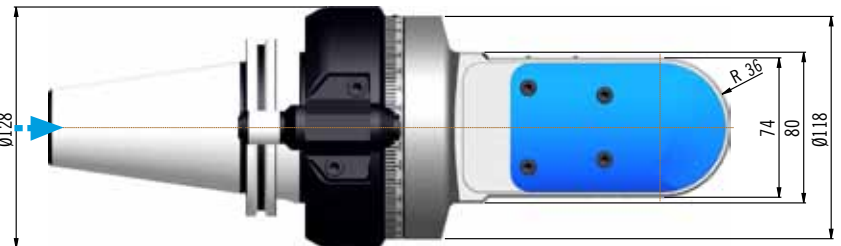
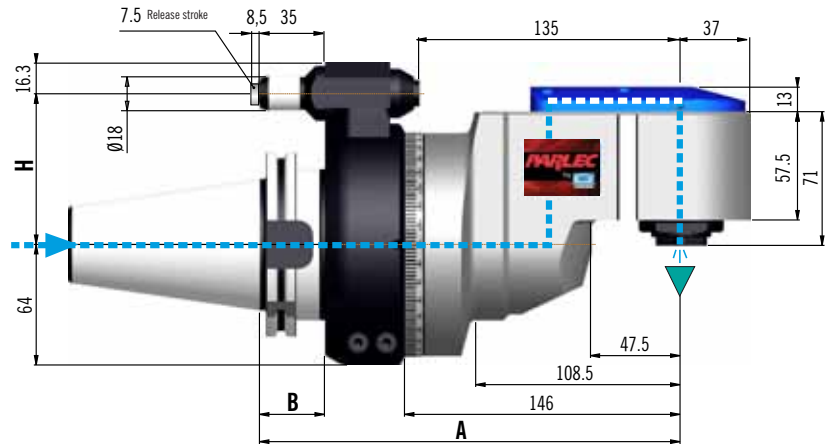

**DRY RUNNING NOT POSSIBLE**

APPLICATION SPECIFICATION

Output Shaft	Range	Ratio	RPM Max	Axial Load Max	Torque	Coolant	Direction
ER 25	1 - 16 mm	1:1	4,000	182lbs (810 N)	708 in/lbs (80 Nm)	1000 PSI (70 Bar)	Same As Spindle
<i>Optional Output Shaft: Weldon</i>						<i>Through the Spindle</i>	

PRODUCT

Description	Shank	A	B	H	H Options	Weight	Spares Included
FR90-16-C50	CAT 50	8.80 (223.5)	1.38 (35)	3.149 (80)	4.33 (110)	25.8 lbs (11.7 Kg)	Stop Block Wrenches Grease Instructions
FR90-16-H100	HSK100A	9.15 (232.5)	1.81 (46)	3.149 (80)	4.33 (110)	25.8 lbs (11.7 Kg)	
FR90-16-CTP8	C8 (ISO 26623)	8.97 (227.8)		3.149 (80)	4.33 (110)	25.8 lbs (11.7 Kg)	
Other Shank Options available: BT 50 , HSK 80, KM 80 and 100							

Order ER25 Collets separately. See pages 47-51.





### FR90-20

Anti-Rotation Interchangeability: **TYPE 2** (See page 52)

Option type 3 anti-rotation available.

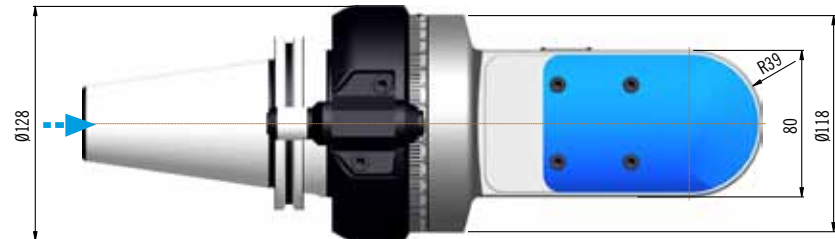
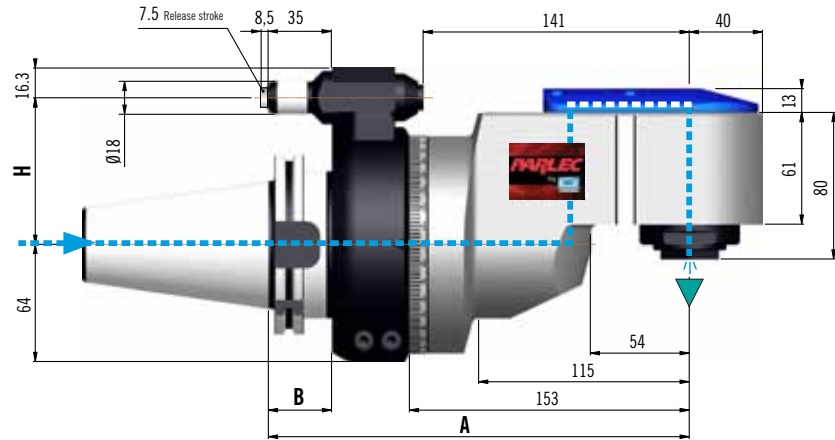

**DRY RUNNING NOT POSSIBLE**

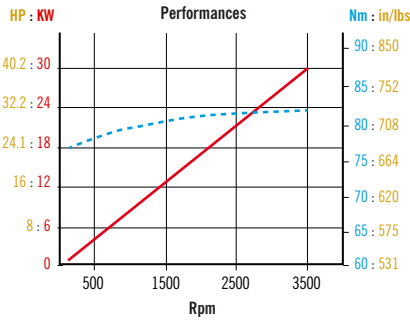

### APPLICATION SPECIFICATION

Output Shaft	Range	Ratio	RPM Max	Axial Load Max	Torque	Coolant	Direction
ER 32	1 - 20 mm	1:1	3,500	258lbs (1150 N)	726 in/lbs (82 Nm)	1000 PSI (70 Bar)	Same as Spindle
Optional Output Shaft: HSK 50A, Weldon				Through the Spindle			

### PRODUCT

Description	Shank	A	B	H	H Options	Weight	Spares Included
FR90-20-C50	CAT 50	9.06 (230)	1.38 (35)	3.149 (80)	4.33 (110)	32 lbs (14.5 Kg)	Stop Block
FR90-20-H100	HSK100A	9.41 (239)	1.81 (46)	3.149 (80)	4.33 (110)	32 lbs (14.5 Kg)	Wrenches
FR90-20-CTP8	C8 (ISO 26623)	9.21 (234)		3.149 (80)	4.33 (110)	32 lbs (14.5 Kg)	Grease
Instructions							
Other Shank Options available: C5, C6, and KM 63							

Order ER32 Collets separately. See pages 47-51.



FMU-10

Anti-Rotation Interchangeability: **TYPE 1** (See page 52)

Option type 2 and 3 anti-rotation available.

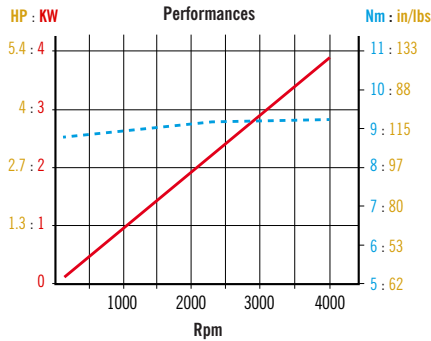
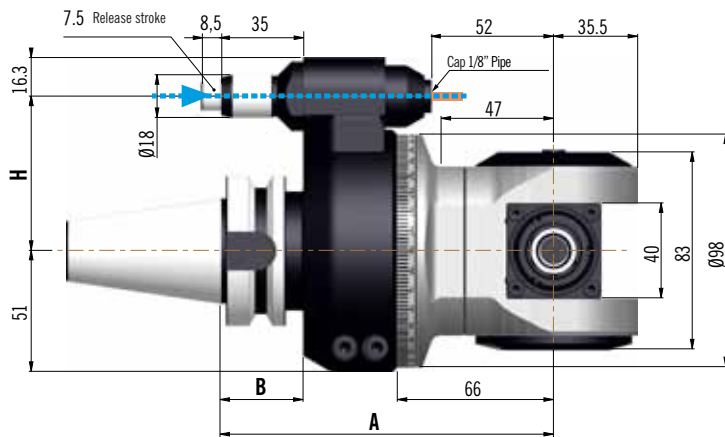
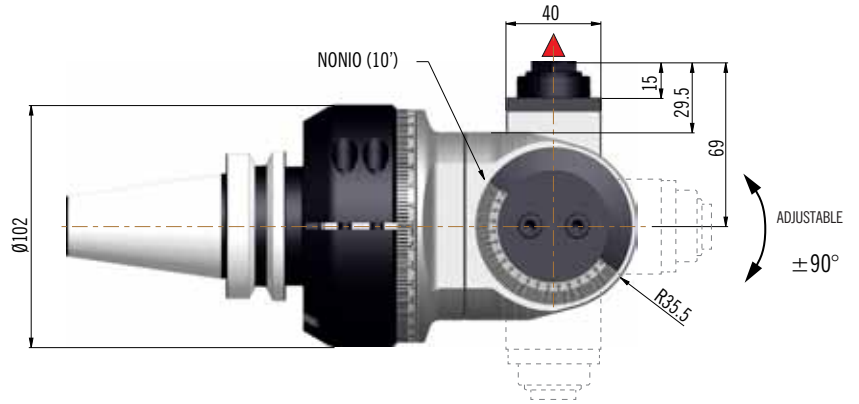
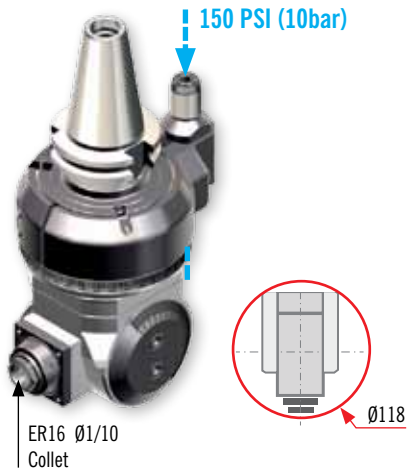

APPLICATION SPECIFICATION

Output Shaft	Range	Ratio	RPM Max	Axial Load Max	Torque	Coolant	Direction
ER 16	1 - 10 mm	1:1	4,000	124lbs (550 N)	80 in/lbs (9 Nm)	Positioning Pin	Opposite Spindle
<i>Optional Output Shaft: Weldon</i>			<i>Configured for optional internal air pressure</i>				

PRODUCT

Description	Shank	A	B	H	H Options	Weight	Spares Included
FMU-10-C40	CAT 40	5.51 (140)	1.38 (35)	2.559 (65)	H=3.149 (80)	13.9 lbs (5.3 Kg)	Stop Block Wrenches Grease Instructions
FMU-10-B40	BT 40	5.51 (140)	1.38 (35)	2.559 (65)	H=3.149 (80)	13.9 lbs (5.3 Kg)	
FMU-10-C50	CAT 50	5.51 (140)	1.38 (35)	3.149 (80)		19.4 lbs (8.8 Kg)	
FMU-10-H63	HSK63A	5.87 (149)	1.73 (44)	2.559 (65)	H=3.149 (80)	13.9 lbs (5.3 Kg)	
FMU-10-H100	HSK100A	5.87 (149)	1.81 (46)	3.149 (80)		19.4 lbs (8.8 Kg)	
<i>Other Shank Options available: C5, C6, C8 (ISO 26623) and KM 63</i>							

Order ER16 Collets separately. See pages 47-51.



## FMU-16

Anti-Rotation Interchangeability: **TYPE 1** (See page 52)

Option type 2 and 3 anti-rotation available.

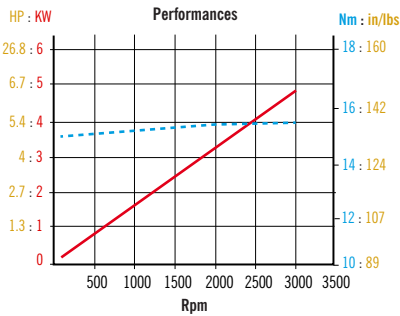
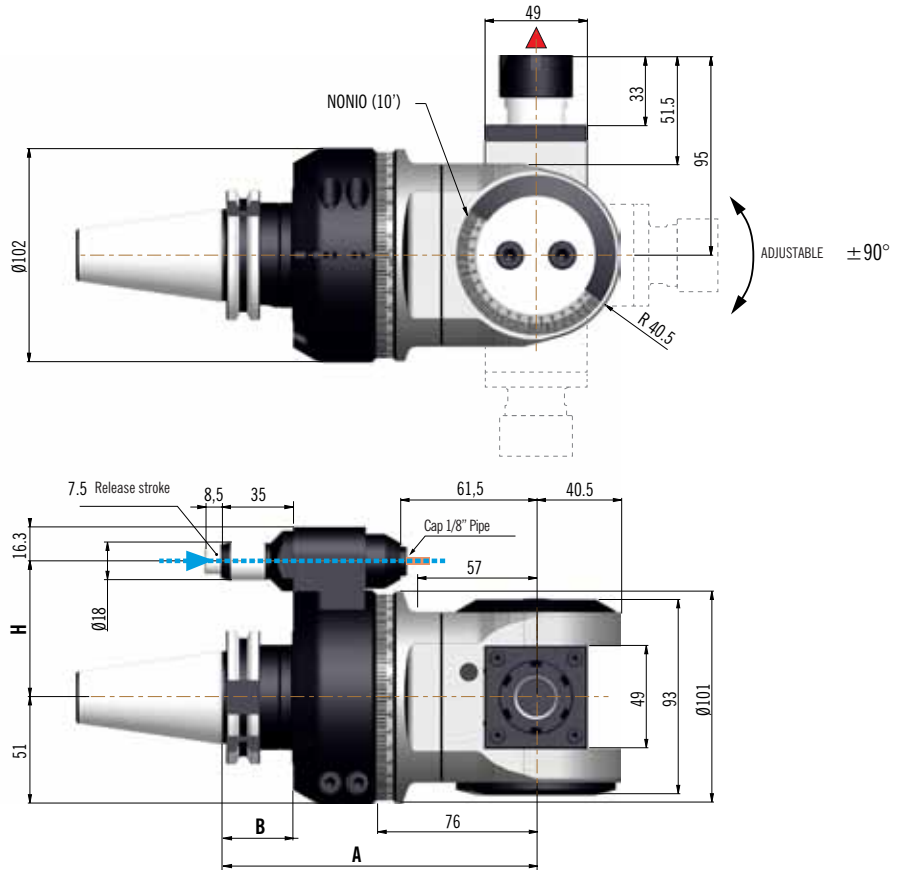
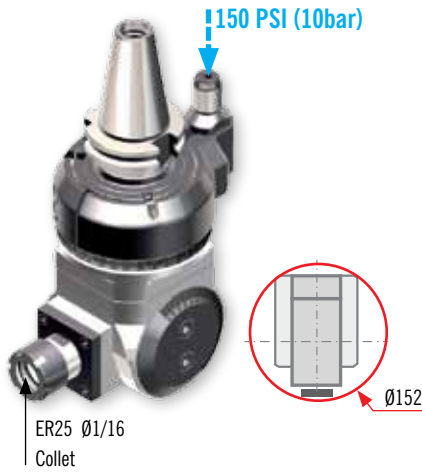

### APPLICATION SPECIFICATION

Output Shaft	Range	Ratio	RPM Max	Axial Load Max	Torque	Coolant	Direction
ER 25	1 - 16 mm	1:1	3,000	142lbs (630 N)	133 in/lbs (15 Nm)	Positioning Pin	Opposite Spindle
Optional Output Shaft: Weldon			Configured for optional internal air pressure				

### PRODUCT

Description	Shank	A	B	H	H Options	Weight	Spares Included
FMU-16-C40	CAT 40	5.90 (150)	1.38 (35)	2.559 (65)	H=3.149 (80)	18 lbs (8.2 Kg)	Stop Block Wrenches Grease Instructions
FMU-16-B40	BT 40	5.90 (150)	1.38 (35)	2.559 (65)	H=3.149 (80)	18 lbs (8.2 Kg)	
FMU-16-C50	CAT 50	5.90 (150)	1.38 (35)	3.149 (80)		23.1 lbs (10.5 Kg)	
FMU-16-H63	HSK63A	6.26 (159)	1.65 (42)	2.559 (65)	H=3.149 (80)	18 lbs (8.2 Kg)	
FMU-16-H100	HSK100A	6.26 (159)	1.81 (46)	3.149 (80)		23.1 lbs (10.5 Kg)	
Other Shank Options available: C5, C6, C8 (ISO 26623) and KM 63							

Order ER25 Collets separately. See pages 47-51.



FMU-20

Anti-Rotation Interchangeability: TYPE 3 (See page 52)

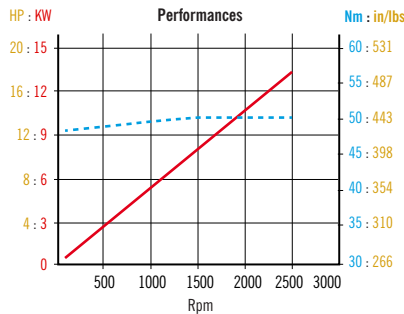
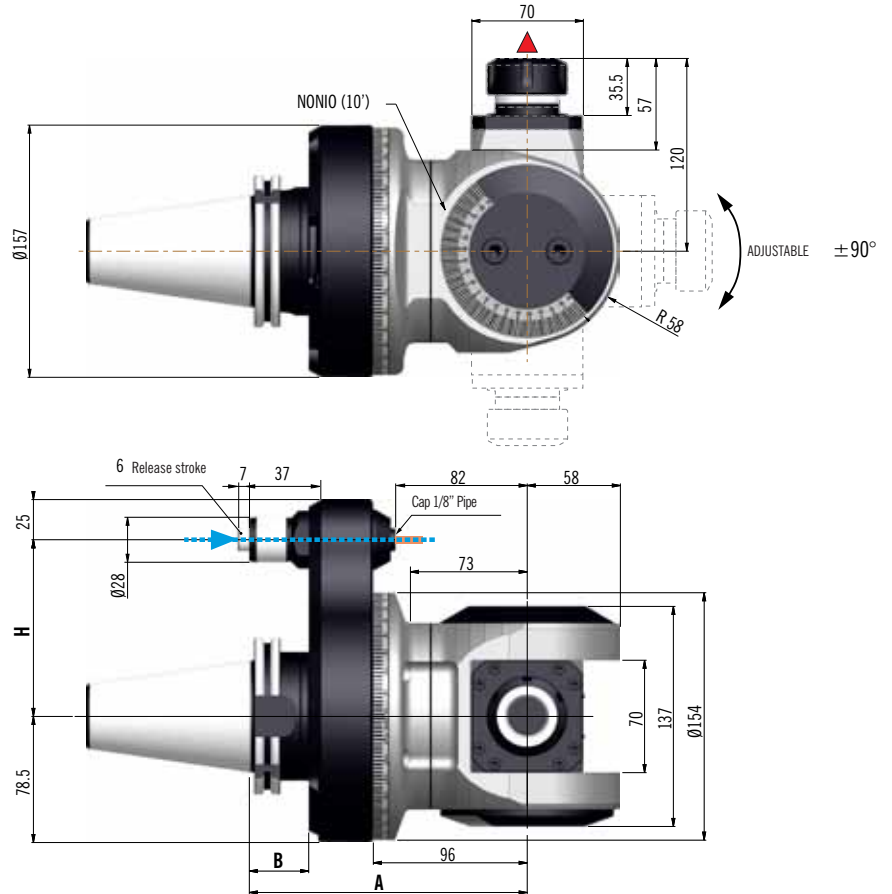

APPLICATION SPECIFICATION

Output Shaft	Range	Ratio	RPM Max	Axial Load Max	Torque	Coolant	Direction
ER 32	1 - 20 mm	1:1	2,500	391lbs (1740 N)	425 in/lbs (48 Nm)	Positioning Pin	Opposite Spindle
Optional Output Shaft: HSK 50A			Configured for optional internal air pressure				

PRODUCT

Description	Shank	A	B	H	H Options	Weight	Spares Included
FMU-20-C50	CAT 50	6.81 (173)	1.46 (37)	4.33 (110)		48 lbs (22 Kg)	Stop Block Wrenches
FMU-20-H100	HSK100A	7.16 (182)	1.89 (48)	4.33 (110)		48 lbs (22 Kg)	Grease
FMU-20-CTP8	C8 (ISO 26623)	6.97 (177)		4.33 (110)		48 lbs (22 Kg)	Instructions
Other Shank Options available: BT 50 , HSK 80, KM 80, and 100							

Order ER32 Collets separately. See pages 47-51.



### MTC SERIES **EVOLUTION LINE** MANUAL TOOL CHANGE

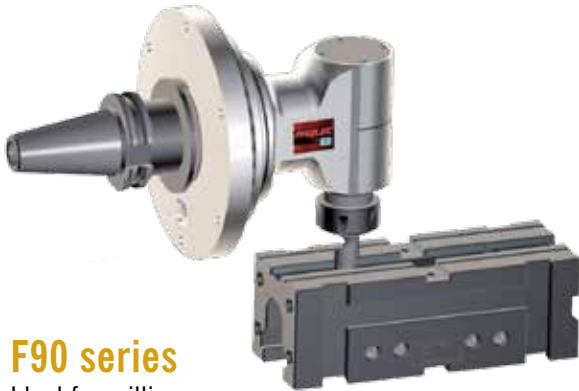

#### F90 series

Ideal for milling, drilling, tapping at  $\pm 90^\circ$



#### F90L series

Long series for machining at deep positions

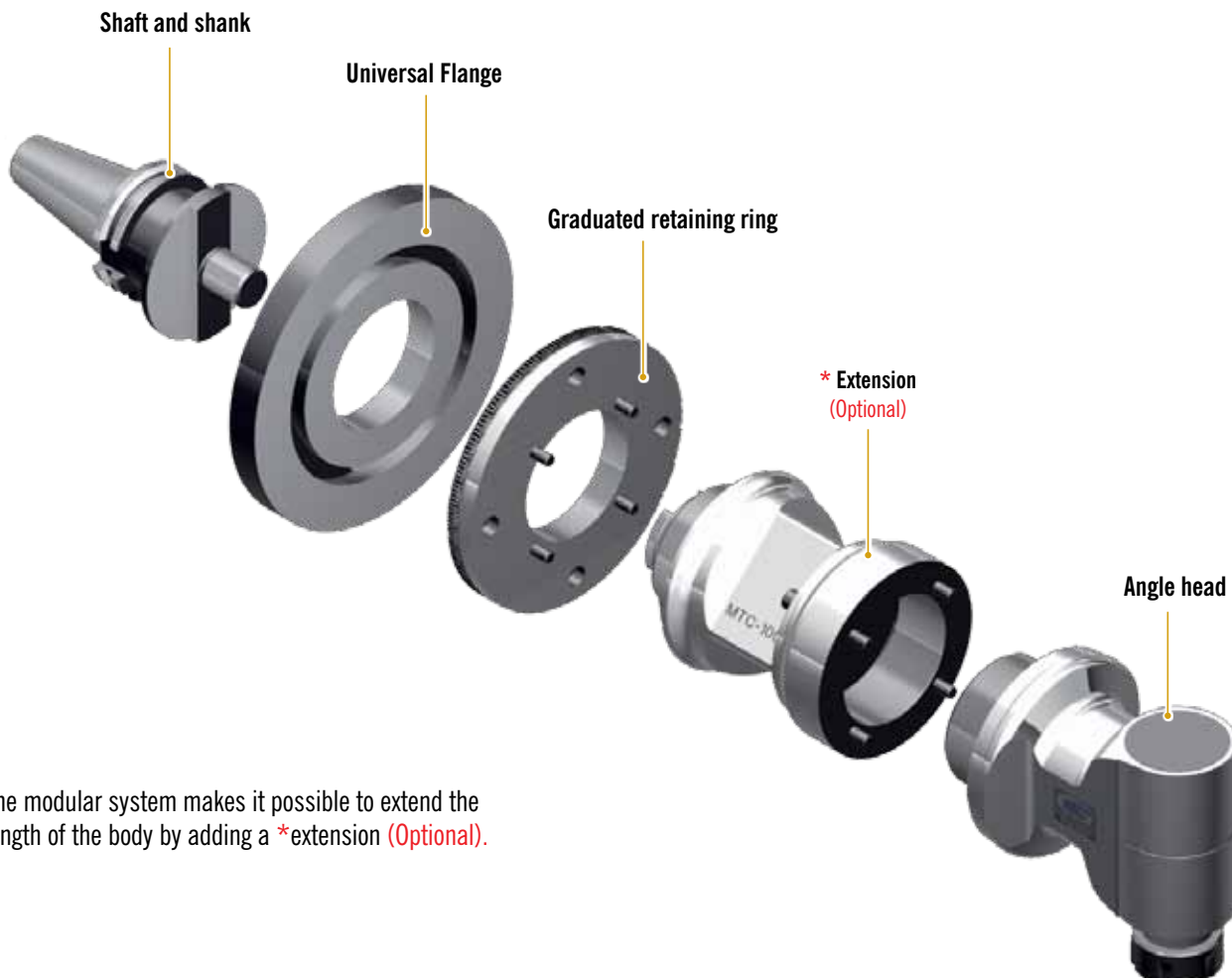

The modular system makes it possible to extend the length of the body by adding a \*extension (Optional).





### INTERNAL COOLANT OPTION MTC SERIES

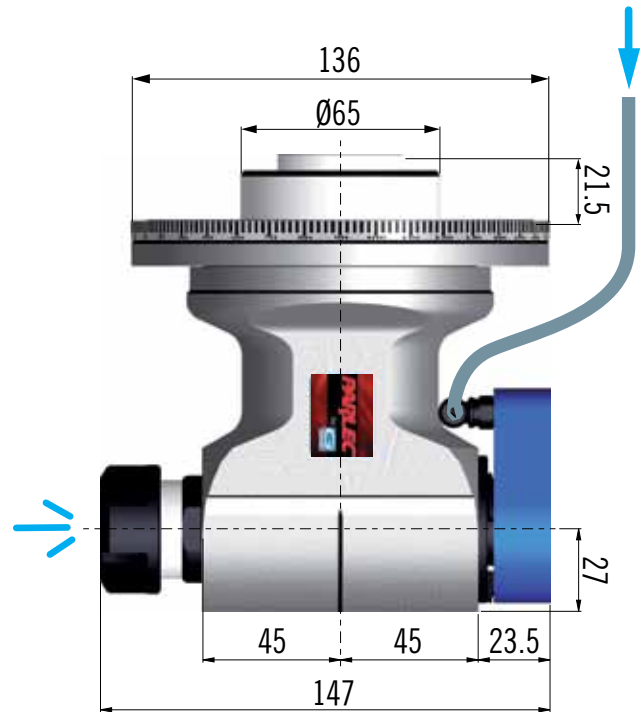

#### F90MTC-16S 150PSI (10bar)

Coolant through the positioning pin and the tool, by rotating distributor

### DOUBLE OUTPUT OPTION MTC SERIES

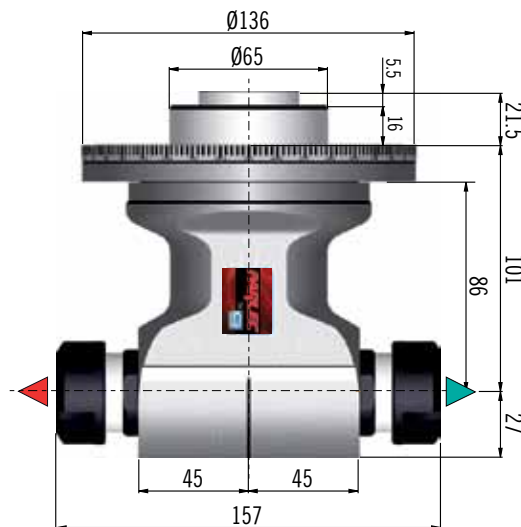

#### F90MTC-16S



## F90MTC-16

Anti Rotation-Interchangeability: **TYPE 1** (See page 52)

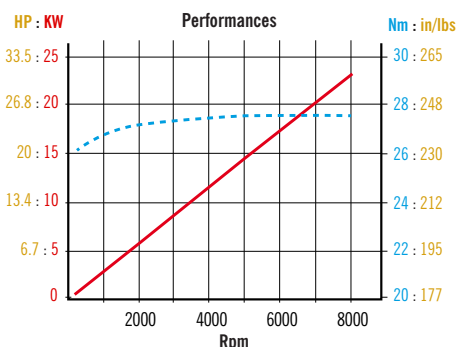
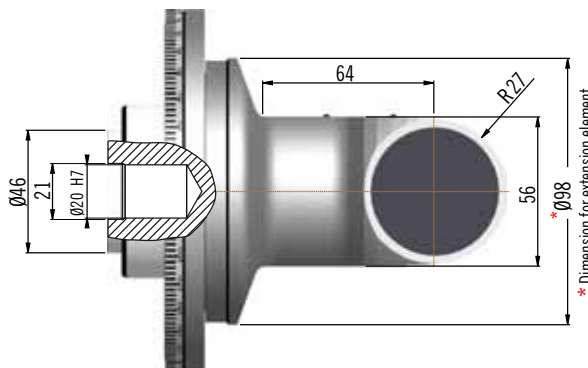
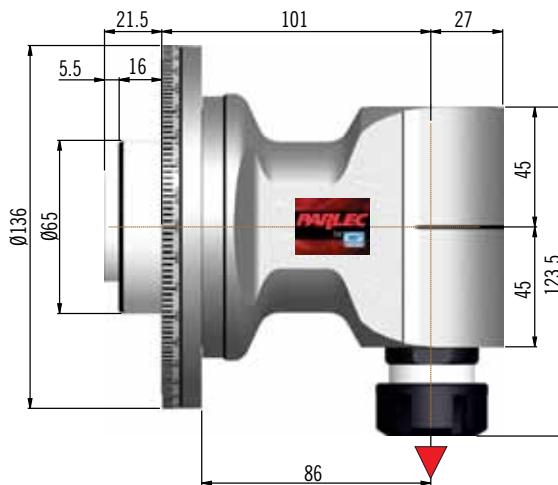
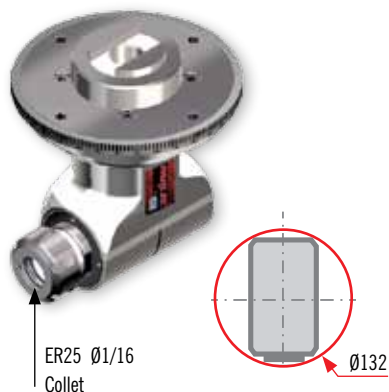

### APPLICATION SPECIFICATION

Output Shaft	Range	Ratio	RPM Max	Axial Load Max	Torque	Coolant	Direction
ER 25	1 - 16 mm	1:1	8,000	182lbs (810 N)	239 in/lbs (27 Nm)	None	Opposite Spindle
Optional Output Shaft: Double ER. Additional Output Shafts available: Weldon, Shell Mill			Configured for optional internal air pressure				

### PRODUCT

Description	Shank	A	Projection length of Drive Shank	Weight (Excluding Flange)	Spares Included
F90MTC-16S-C40	CAT 40	3.98 (101)*	1.38 (35)	14 lbs (6.4 Kg)	Stop Block
F90MTC-16S-B40	BT 40	3.98 (101)*	1.38 (35)	14 lbs (6.4 Kg)	Wrenches
F90MTC-16S-C50	CAT 50	3.98 (101)*	1.38 (35)	19.1 lbs (8.7 Kg)	Grease
F90MTC-16S-H63	HSK63A	3.98 (101)*	1.73 (44)	14 lbs (6.4 Kg)	Instructions
F90MTC-16S-H100	HSK100A	3.98 (101)* *Extension: 100 mm and 200 mm available. See page 56.	1.81 (46)	19.1 lbs (8.7 Kg)	Drive Shank Universal Flange
Other Shank Options available: C5 and C6 (ISO 26623)					

Order ER25 Collets separately. See pages 47-51



**F90MTC-16L**

Anti-Rotation Interchangeability: **TYPE 2** (See page 52)

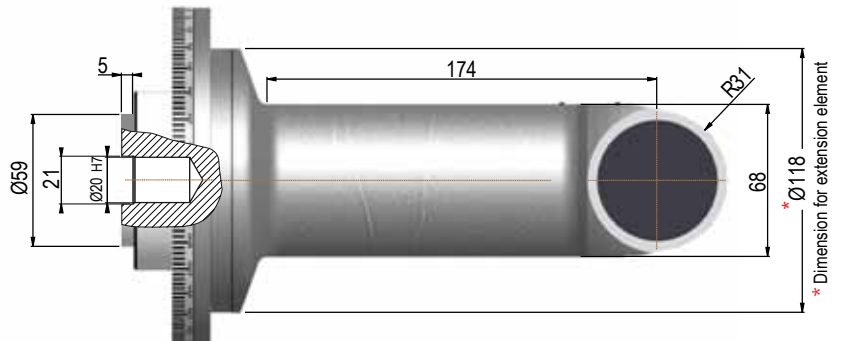
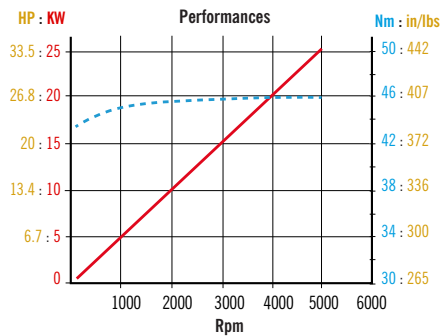
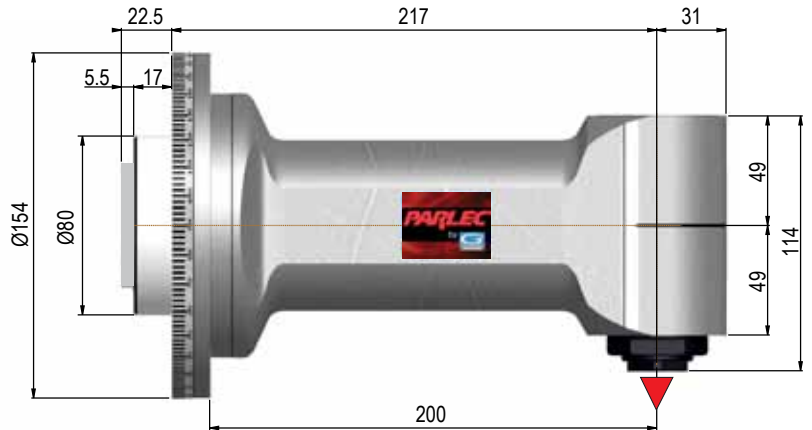

**APPLICATION SPECIFICATION**

Output Shaft	Range	Ratio	RPM Max	Axial Load Max	Torque	Coolant	Direction
ER 25	1 - 16 mm	1:1	5,000	182lbs (810 N)	407 in/lbs (46 Nm)	None	Opposite Spindle
Optional Output Shaft: Double ER. Additional Output Shafts available: Weldon, Shell Mill, HSK32A					Configured for optional internal air pressure		

**PRODUCT**

Description	Shank	A	Projection length of Drive Shank	Weight	Spares Included
F90MTC-16L-C50	CAT 50	8.54 (217)*	1.38 (35)		Stop Block Wrenches Grease
F90MTC-16L-H100	HSK100A	8.54 (217)*	1.81 (46)		Instructions Drive Shank Universal Flange
F90MTC-16L-CTP8	C8 (ISO 26623)	8.54 (217)* * Extension: 100 mm and 200 mm available. See page 56.			
Other Shank Options available: C5 and C6 (ISO 26623)					

Order ER25 Collets separately. See pages 47-51



## F90MTC-20

Anti-Rotation Interchangeability: **TYPE 2** (See page 52)

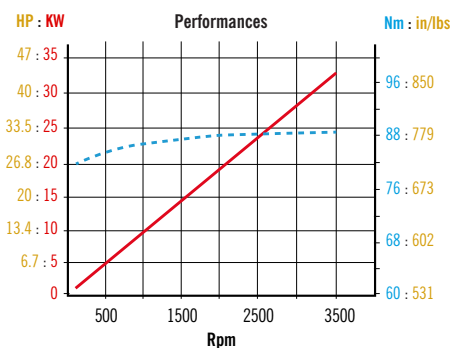
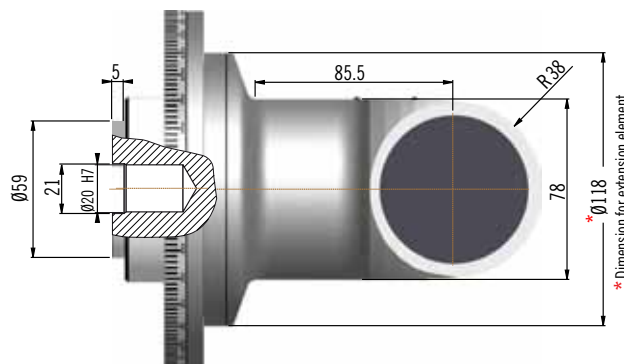
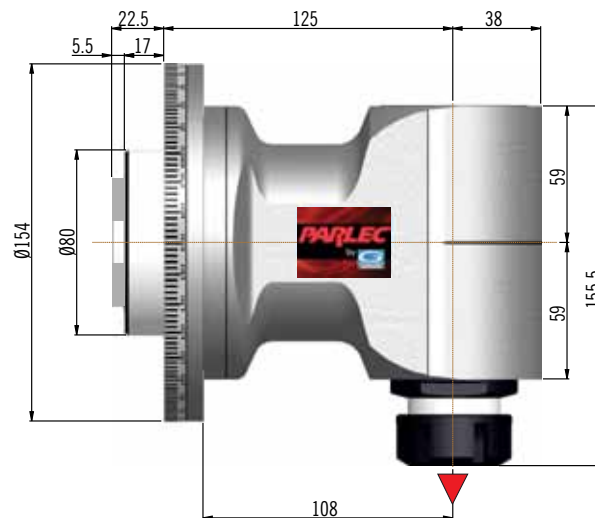
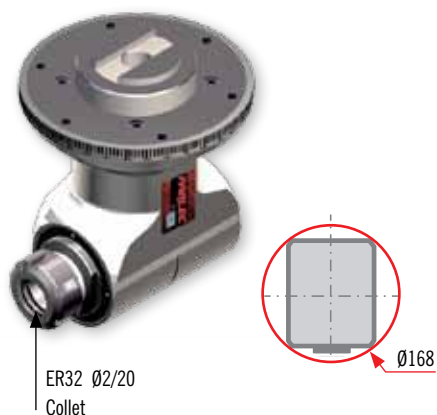

### APPLICATION SPECIFICATION

Output Shaft	Range	Ratio	RPM Max	Axial Load Max	Torque	Coolant	Direction
ER 32	1 - 20 mm	1:1	3,500	328lbs (1460 N)	752 in/lbs (85 Nm)	None	Opposite Spindle
Optional Output Shaft: Double ER. Additional Output Shafts available: Weldon, HSK40A, Cpt4, Shell Mill			Configured for optional internal air pressure				

### PRODUCT

Description	Shank	A	Projection length of Drive Shank	Spares Included
F90MTC-20-C50	CAT 50	4.92 (125)*	1.38 (35)	Stop Block Wrenches Grease Instructions Drive Shank Universal Flange
F90MTC-20-H100	HSK100A	4.92 (125)*	1.81 (46)	
F90MTC-20-CTP8	C8 (ISO 26623)	4.92 (125)* * Extension: 100 mm and 200 mm available. See page 56.		
Other Shank Options available: C5 and C6 (ISO 26623)				

Order ER32 Collets separately. See page 47-51.



F90MTC-20L

Anti-Rotation Interchangeability: **TYPE 2** (See page 52)

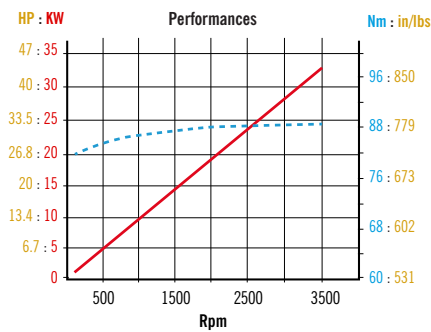
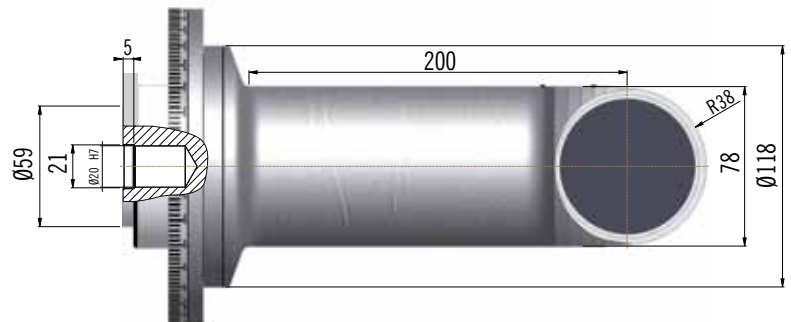
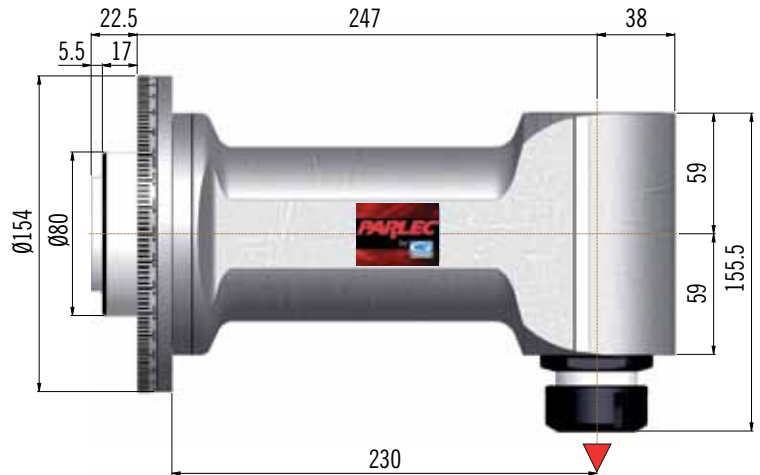
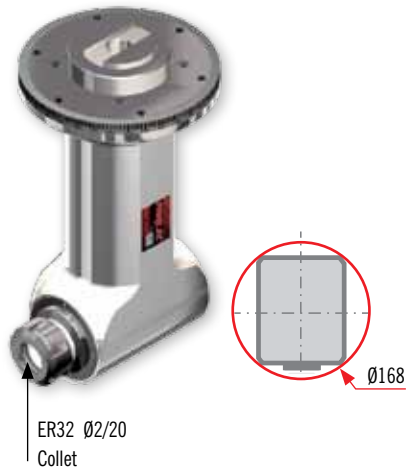

APPLICATION SPECIFICATION

Output Shaft	Range	Ratio	RPM Max	Axial Load Max	Torque	Coolant	Direction
ER 32	1 - 20 mm	1:1	3,500	328lbs (1460 N)	752 in/lbs (85 Nm)	None	Opposite Spindle
Optional Output Shaft: Double ER. Additional Output Shafts available: Weldon, HSK40A, Cpt4, Shell Mill					Configured for optional internal air pressure		

PRODUCT

Description	Shank	A	Projection length of Drive Shank	Spares Included
F90MTC-20L-C50	CAT 50	9.72 (247)*	1.38 (35)	Stop Block Wrenches Grease Instructions Drive Shank Universal Flange
F90MTC-20L-H100	HSK100A	9.72 (247)*	1.81 (46)	
F90MTC-20L-CTP8	C8 (ISO 26623)	9.72 (247)* * Extension: 100 mm and 200 mm available. See page 56		
Other Shank Options available: C5 and C6 (ISO 26623)				

Order ER32 Collets separately. See page 47-51.





### F90MTC-40

Anti-Rotation Interchangeability: **TYPE 3** (See page 52)

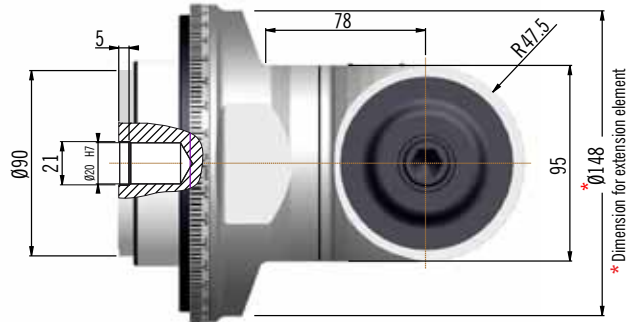
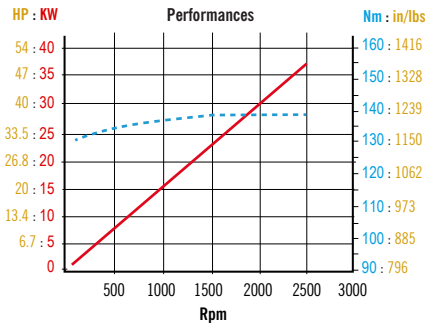
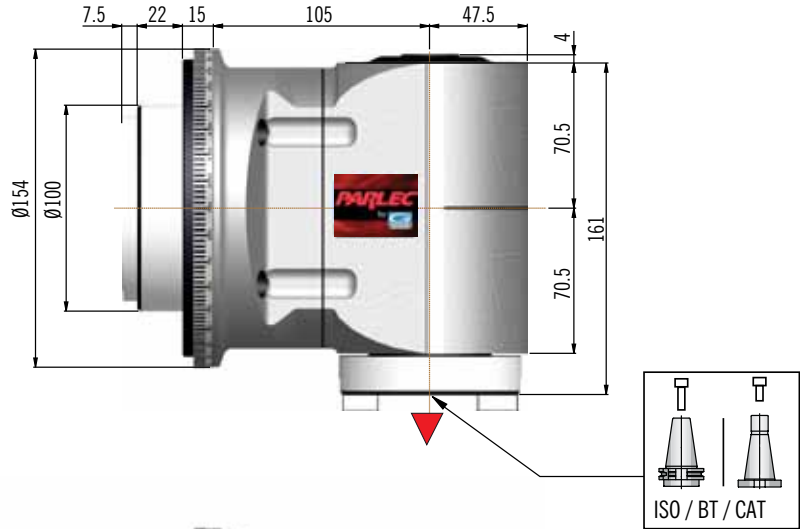
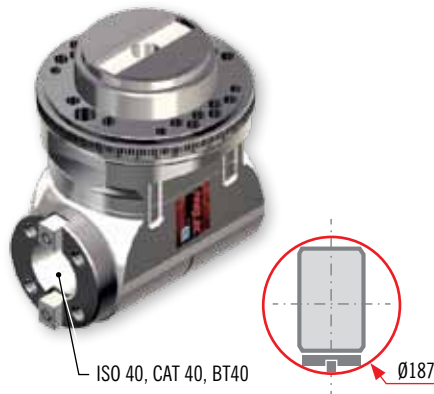

### APPLICATION SPECIFICATION

Output Shaft	Range	Ratio	RPM Max	Axial Load Max	Torque	Coolant	Direction
ISO 40		1:1	2,500	680lbs (3020 N)	1196 in/lbs (135 Nm)	None	Opposite Spindle
Optional Output Shaft: Double ER. Additional Output Shafts available: HSK63A, CPT5, ER40			Configured for optional internal air pressure				

### PRODUCT

Description	Shank	A	Projection length of Drive Shank	Spares Included
F90MTC-S40-C50	CAT 50	4.13 (105)*	1.38 (35)	Stop Block Wrenches Grease Instructions
F90MTC-S40-H100	HSK100A	4.13 (105)*	1.81 (46)	
F90MTC-S40-CTP8	C8 (ISO 26623)	4.13 (105)* *Extension: 100 mm and 200 mm available. See page 56.		
Other Shank Options available: C5 and C6 (ISO 26623)				



# ATC & MTC SERIES *Evolution Line* ACCESSORIES

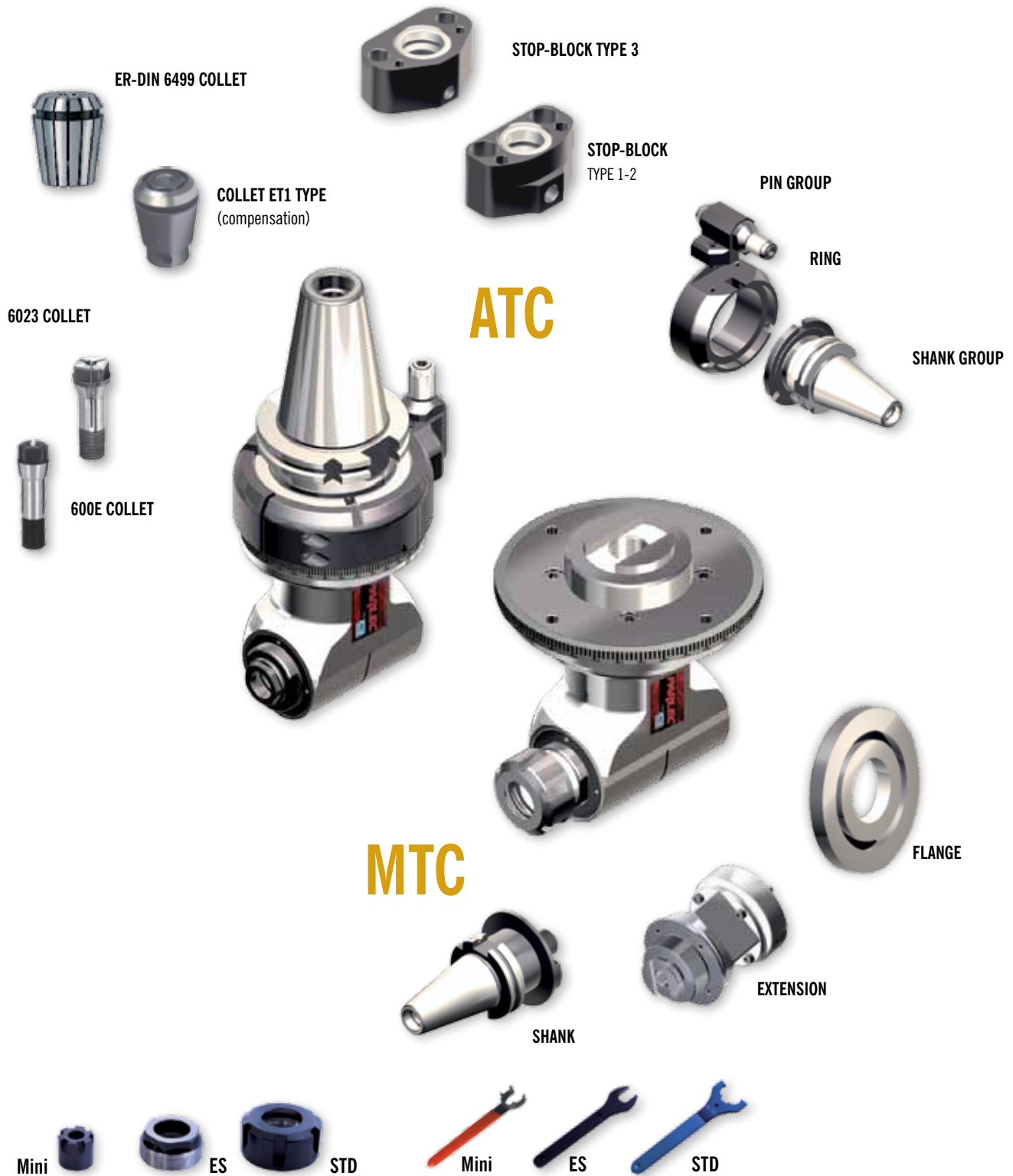



6023 COLLET



600E COLLET



### SPARE NUTS AND WRENCHES

Angle Head	Nut Style	Part Number	Nut Wrench	Output Shaft Wrench
FS90-3			5.5 mm Hex	
FS90-3L				
FS90-4				
FS90-4L				
F90-07	ER11-ES	9.ER.110ES	13 mm Hex	22 mm Hex
F90-07L				
F90-10	ER16-ES	9.ER.160ES	19 mm Hex	30 mm Hex
F90-10L				
FMU-10				
FR90-10				27 mm Hex
F90-16S	ER25-STD	25ERN	25ERNW	32 mm Hex
F90-16	ER25-ES	9.ER.250ES	27 mm Hex	38 mm Hex
F90-16L				
FR90-16				36 mm Hex
FMU-16	ER25 Mini	9.ER.2500M	9.CH.2500M	27 mm Hex
F90-20	ER32-STD	32ERN	32ERNW	47 mm Hex
FMU-20	ER32-STD	32ERN	32ERNW	40 mm Hex
FR90-20	ER32-ES	9.ER.320ES	32 mm Hex	47 mm Hex
F90-30D	ER40-STD	40ERN	40ERNW	

### COLLETS 6023E AND 600E

Part Number	Type	Size
9.60.23E0010	6023E	1 mm
9.60.23E0015		1.5 mm
9.60.23E0020		2 mm
9.60.23E0025		2.5 mm
9.60.23E0030		3 mm
9-60.0E0010	600E	1 mm
9-60.0E0015		1.5 mm
9-60.0E0020		2 mm
9-60.0E0025		2.5 mm
9-60.0E0030		3 mm
9-60.0E0035		3.5 mm
9-60.0E0040		4 mm



COLLET PERFORMANCE CHOICES



Collet Selection

<p><b>ER STANDARD COLLET</b> (ER Standard Collets see page 48-50)</p>	<ul style="list-style-type: none"> <li>■ For use in ER collet chucks for drilling, reaming, boring, tapping, and milling.</li> <li>■ Meets DIN 6499-B industry standard.</li> <li>■ Collapse range .0393”(1 mm) maximum.</li> <li>■ Size 11 collapse range .020”(1/2 mm) maximum.</li> <li>■ For higher runout tolerance use HIGH CONCENTRICITY GRADE AA COLLETS</li> </ul>
<p><b>ER TAP COLLETS</b> (ER Tap Collets see page 51)</p>	<ul style="list-style-type: none"> <li>■ Designed for use with production ER Tapping tools.</li> <li>■ Provide maximum concentricity with positive driving force.</li> </ul>
<p><b>ER GRADE AA 5 MICRON COLLET</b> <i>HIGH CONCENTRICITY</i>  (ER Grade AA 5 Micron Collets see page 52-54)</p>	<ul style="list-style-type: none"> <li>■ Evenly distributed cutting edges for high performance machining.</li> <li>■ .0002” (5 micron) gage tolerance.</li> <li>■ Exceeds DIN requirements.</li> <li>■ Recommended use on size.</li> <li>■ 12 slots, deburred and polished.</li> <li>■ Increased grip force with reduced friction to collet seat.</li> <li>■ Improve system performance and lower cost per piece when used with a quality chuck.</li> </ul>

Collet Selection with Coolant Options

<p><b>ERS STEEL SEALED COLLET</b> (ER Steel Sealed Collets see page 55-56)</p>	<ul style="list-style-type: none"> <li>■ For use with regular straight shank tools.</li> <li>■ Withstands coolant pressure up to 1800 PSI.</li> <li>■ Collet collapse is .005”.</li> </ul>
<p><b>COOLANT NUT SEAL SYSTEM</b> (Coolant Seals see page 57)</p>	<ul style="list-style-type: none"> <li>■ Allows full range of collet when used with standard collets.</li> <li>■ Allows coolant seal with AA grade collets.</li> <li>■ Prevents abrasive machining dust of chips from contaminating collet system.</li> <li>■ Seals up to 1200psi.</li> </ul>

Collet Dimensions

TYPE	ER11	ER16	ER20	ER25	ER32	ER40
LENGTH (L)	0.708	1.082	1.240	1.338	1.574	1.811
DIAMETER (D)	0.452	0.669	0.827	1.023	1.300	1.614



### RELIABLE CLAMPING SYSTEM FOR PRODUCTION WORK



ER Standard Collet

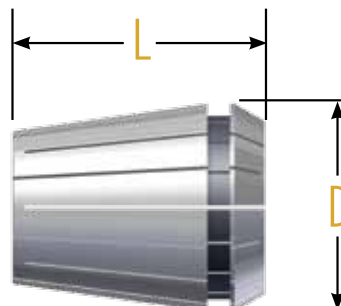

\* For specifications see page 47

### ER11 STANDARD COLLETS - METRIC

PART NUMBER	Metric Range
ER11 Metric	
ER11-0039	.5-1 mm
ER11-0059	1-1.5 mm
ER11-0078	1-2 mm
ER11-0098	1.5-2.5 mm
ER11-0118	2-3 mm
ER11-0137	2.5-3.5 mm
ER11-0157	3-4 mm
ER11-0177	4-4.5 mm
ER11-0196	4-5 mm
ER11-0216	4.5-5.5 mm
ER11-0236	5-6 mm
ER11-0255	5.5-6.5 mm
ER11-0275	6-7 mm

#### ER11 Metric Set

#### SETS

ER11-S013	PART NUMBER
13 Pieces	NUMBER OF PIECES
.5-7 mm	RANGE

### ER11 STANDARD COLLETS - INCH

PART NUMBER	Inch Range
ER11 Inch	
ER11-0062	.0428-.0625
ER11-0093	.0740-.0938
ER11-0125	.1053-.1250
ER11-0157	.1378-.1575
ER11-0187	.1678-.1875
ER11-0218	.1990-.2187
ER11-0250	.2303-.2500

#### ER11 Inch Set

#### SETS

ER11-S007	PART NUMBER
7 Pieces	NUMBER OF PIECES
1/16" - 1/4"	RANGE





ER Standard Collet

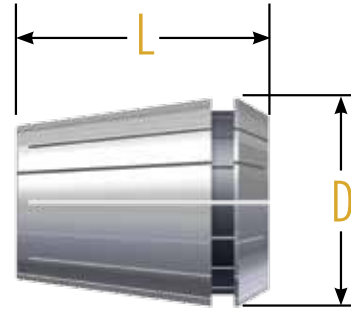

\* For specifications see page 47

ER16-ER40 ER STANDARD COLLETS - INCH

PART NUMBER					
ER16 Inch	ER20 Inch	ER25 Inch	ER32 Inch	ER40 Inch	Inch Range
ER16-0031					0.0312
ER16-0062	ER20-0062	ER25-0062			.0400-.0620
ER16-0093	ER20-0093	ER25-0093	ER32-0093		.0540-.0930
ER16-0125	ER20-0125	ER25-0125	ER32-0125	ER40-0125	.0860-.1250
ER16-0156	ER20-0156	ER25-0156	ER32-0156		.1170-.1560
ER16-0187	ER20-0187	ER25-0187	ER32-0187	ER40-0187	.1480-.1870
ER16-0218	ER20-0218	ER25-0218	ER32-0218	ER40-0218	.1790-.2180
ER16-0250	ER20-0250	ER25-0250	ER32-0250	ER40-0250	.2110-.2500
ER16-0281	ER20-0281	ER25-0281	ER32-0281	ER40-0281	.2420-.2810
ER16-0312	ER20-0312	ER25-0312	ER32-0312	ER40-0312	.2730-.3120
ER16-0343	ER20-0343	ER25-0343	ER32-0343	ER40-0343	.3040-.3430
ER16-0375	ER20-0375	ER25-0375	ER32-0375	ER40-0375	.3360-.3750
ER16-0406	ER20-0406	ER25-0406	ER32-0406	ER40-0406	.3666-.4060
	ER20-0437	ER25-0437	ER32-0437	ER40-0437	.3980-.4370
	ER20-0468	ER25-0468	ER32-0468	ER40-0468	.4290-.4680
	ER20-0500	ER25-0500	ER32-0500	ER40-0500	.4610-.5000
		ER25-0531	ER32-0531	ER40-0531	.4920-.5310
		ER25-0562	ER32-0562	ER40-0562	.5230-.5620
		ER25-0593	ER32-0593	ER40-0593	.5544-.5937
		ER25-0625	ER32-0625	ER40-0625	.5860-.6250
			ER32-0656	ER40-0656	.6170-.6560
			ER32-0687	ER40-0687	.6480-.6870
			ER32-0718	ER40-0718	.6794-.7187
			ER32-0750	ER40-0750	.7110-.7500
				ER40-0781	.7419-.7812
				ER40-0812	.7732-.8125
				ER40-0843	.8044-.8437
				ER40-0875	.8360-.8750
				ER40-0905	.8669-.9062
				ER40-0937	.8982-.9375
				ER40-0984	.9449-.9843
				ER40-1000	.9610-1.0000

ER16 Inch Set	ER20 Inch Set	ER25 Inch Set	ER32 Inch Set	ER40 Inch Set	SETS
ER16-S012	ER20-S014	ER25-S016	ER32-S022	ER40-S024	PART NUMBER
12 Pieces	14 Pieces	15 Pieces	22 Pieces	24 Pieces	NUMBER OF PIECES
1/16"-13/32"	3/32"-1/2"	3/16"-5/8"	3/32"-3/4"	9/32"-1"	RANGE



## ER16-ER40 ER STANDARD COLLETS - METRIC

PART NUMBER					Metric Range
ER16 Metric	ER20 Metric	ER25 Metric	ER32 Metric	ER40 Metric	
ER16-0039					.5-1 mm
ER16-0078	ER20-0078	ER25-0078			1-2 mm
ER16-0098					2-2.5 mm
ER16-0118	ER20-0118	ER25-0118	ER32-0118		2-3 mm
ER16-0137					2.5-3.5 mm
ER16-0157	ER20-0157	ER25-0157	ER32-0157	ER40-0157	3-4 mm
ER16-0177					3.5-4.5 mm
ER16-0196	ER20-0196	ER25-0196	ER32-0196	ER40-0196	4-5 mm
ER16-0216					4.5-5.5 mm
ER16-0236	ER20-0236	ER25-0236	ER32-0236	ER40-0236	5-6 mm
ER16-0255					5.5-6.5 mm
ER16-0275	ER20-0275	ER25-0275	ER32-0275	ER40-0275	6-7 mm
ER16-0295					6.5-7.5 mm
ER16-0315	ER20-0315	ER25-0315	ER32-0315	ER40-0315	7-8 mm
ER16-0334					7.5-8.5 mm
ER16-0354	ER20-0354	ER25-0354	ER32-0354	ER40-0354	8-9 mm
ER16-0393	ER20-0393	ER25-0393	ER32-0393	ER40-0393	9-10 mm
	ER20-0433	ER25-0433	ER32-0433	ER40-0433	10-11 mm
	ER20-0472	ER25-0472	ER32-0472	ER40-0472	11-12 mm
	ER20-0511	ER25-0511	ER32-0511	ER40-0511	12-13 mm
		ER25-0551	ER32-0551	ER40-0551	13-14 mm
		ER25-0590	ER32-0590	ER40-0590	14-15 mm
		ER25-0630	ER32-0630	ER40-0630	15-16 mm
			ER32-0669	ER40-0669	16-17 mm
			ER32-0708	ER40-0708	17-18 mm
			ER32-0748	ER40-0748	18-19 mm
			ER32-0787	ER40-0787	19-20 mm
				ER40-0826	20-21 mm
				ER40-0866	21-22 mm
				ER40-0905	22-23 mm
				ER40-0944	23-24 mm
				ER40-0984	24-25 mm
				ER40-1023	25-26 mm
				ER40-1063	26-27 mm
				ER40-1102	27-28 mm
				ER40-1141	28-29 mm
				ER40-1181	29-30 mm

ER16 Metric Set	ER20 Metric Set	ER25 Metric Set	ER32 Metric Set	ER40 Metric Set	SETS
ER16-S010	ER20-S012	ER25-S015	ER32-S018	ER40-S023	
10 Pieces	12 Pieces	15 Pieces	18 Pieces	23 Pieces	NUMBER OF PIECES
1-10 mm x 1 mm	2-13 mm	2-16 mm	3-20 mm	4-26 mm	RANGE



**PROVIDES MAXIMUM TAP CONCENTRICITY WITH POSITIVE DRIVE FORCE**



ERT Tap Collet

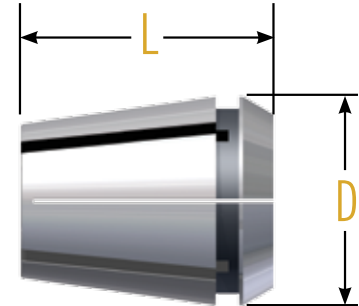

\* For specifications see page 47

**ER16-ER40 ERT COLLETS - INCH METRIC**

PART NUMBER					Inch Range	ANSI Metric
ER16	ER20	ER25	ER32	ER40		
ERT16- #8	ERT20- #8	ERT25- #8	ERT32- #8	ERT40- #8	#8	M4
ERT16- #10	ERT20- #10	ERT25- #10	ERT32- #10	ERT40- #10	#10	M4.5, M5
ERT16- #12	ERT20- #12	ERT25- #12	ERT32- #12	ERT40- #12	#12	
		ERT25-012N	ERT32-012N	ERT40-012N	1/8" NPT	
ERT16- 25	ERT20-25	ERT25-25	ERT32-25	ERT40-25	1/4"	M6, M6.5
			ERT32-25N	ERT40-25N	1/4" NPT	
ERT16-31	ERT20-31	ERT25-31	ERT32-31	ERT40-31	5/16"	M7, M8
ERT16-37	ERT20-37	ERT25-37	ERT32-37	ERT40-37	3/8"	M10
				ERT40-37N	3/8" NPT	
ERT16-43	ERT20-43	ERT25-43	ERT32-43	ERT40-43	7/16"	
ERT16-50	ERT20-50	ERT25-50	ERT32-50	ERT40-50	1/2"	M12, M12.5
				ERT40-50N	1/2" NPT	
		ERT25-056	ERT32-056	ERT40-056	9/16"	M14
		ERT25-062	ERT32-062	ERT40-062	5/8"	M16
			ERT32-068	ERT40-068	11/16"	M18
			ERT32-075	ERT40-075	3/4"	
			ERT32-081	ERT40-081	13/16"	M20
				ERT40-087	7/8"	M22
				ERT40-093	15/16"	M24
				ERT40-100	1"	M25



## THE NEW STANDARD IN PERFORMANCE GRADE TOOL HOLDING



ER Grade AA  
5 Micron Collet

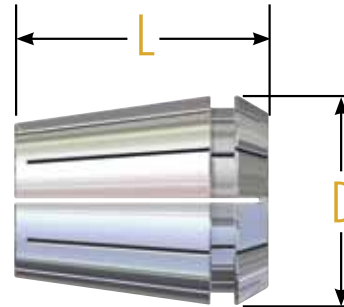

\* For specifications see page 11

## AA GRADE 5 MICRON ER PRECISION COLLETS - ER 11

PART NUMBER		
ER11 METRIC	Recommended Usage $\pm .004"$ (.1 mm)	Maximum Collapse Range
5UMER11-0039	1 mm	0.5 mm
5UMER11-0059	1.5 mm	0.5 mm
5UMER11-0078	2 mm	0.5 mm
5UMER11-0098	2.5mm	0.5 mm
5UMER11-0118	3 mm	0.5 mm
5UMER11-0137	3.5 mm	0.5 mm
5UMER11-0157	4 mm	0.5 mm
5UMER11-0177	4.5 mm	0.5 mm
5UMER11-0196	5 mm	0.5 mm
5UMER11-0216	5.5 mm	0.5 mm
5UMER11-0236	6 mm	0.5 mm
5UMER11-0255	6.5 mm	0.5 mm
5UMER11-0275	7 mm	0.5 mm
PART NUMBER		
ER11 INCH	Recommended Usage $\pm .004"$ (.1 mm)	Maximum Collapse Range
5UMER11-0062	1/16"	0.5 mm
5UMER11-0093	3/32"	0.5 mm
5UMER11-0125	1/8"	0.5 mm
5UMER11-0156	5/32"	0.5 mm
5UMER11-0187	3/16"	0.5 mm
5UMER11-0218	7/32"	0.5 mm
5UMER11-0250	1/4"	0.5 mm

## SETS

	ER11 Metric Set	ER11 Inch Set
PART NUMBER	5UMER11-SM013	5UMER11-SI007
NUMBER OF PIECES	13 Pieces	13 Pieces
RANGE	1-7 mm	1/16"-1/4"



ER Grade AA  
5 Micron Collet

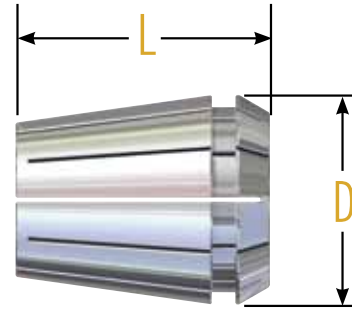

\* For specifications see page 11

**AA GRADE 5 MICRON ER PRECISION COLLETS - INCH**

PART NUMBER					Recommended Usage = /- .004" (.1 mm)	Maximum Collapse Range
ER16 Inch	ER20 Inch	ER25 Inch	ER32 Inch	ER40 Inch		
5UMER16-0062					1/16"	0.5 mm
5UMER16-0093					3/32"	0.5 mm
5UMER16-0125	5UMER20-0125	5UMER25-0125	5UMER32-0125	5UMER40-0125	1/8"	1 mm
5UMER16-0156	5UMER20-0157	5UMER25-0157	5UMER32-0157	5UMER40-0157	5/32"	1 mm
5UMER16-0187	5UMER20-0187	5UMER25-0187	5UMER32-0187	5UMER40-0187	3/16"	1 mm
5UMER16-0218					7/32"	1 mm
5UMER16-0250	5UMER20-0250	5UMER25-0250	5UMER32-0250	5UMER40-0250	1/4"	1 mm
5UMER16-0281					9/32"	1 mm
5UMER16-0312	5UMER20-0312	5UMER25-0312	5UMER32-0312	5UMER40-0312	5/16"	1 mm
5UMER16-0343					11/32"	1 mm
5UMER16-0375	5UMER20-0375	5UMER25-0375	5UMER32-0375	5UMER40-0375	3/8"	1 mm
5UMER16-0406					13/32"	1 mm
	5UMER20-0437	5UMER25-0437	5UMER32-0437	5UMER40-0437	7/16"	1 mm
	5UMER20-0472	5UMER25-0472	5UMER32-0472	5UMER40-0472	15/32"	1 mm
	5UMER20-0500	5UMER25-0500	5UMER32-0500	5UMER40-0500	1/2"	1 mm
		5UMER25-0562	5UMER32-0562	5UMER40-0562	9/16"	1 mm
		5UMER25-0625	5UMER32-0625	5UMER40-0625	5/8"	1 mm
			5UMER32-0687	5UMER40-0687	11/16"	1 mm
			5UMER32-0750	5UMER40-0750	3/4"	1 mm
			5UMER32-0812	5UMER40-0812	13/16"	1 mm
				5UMER40-0875	7/8"	1 mm
				5UMER40-1000	1"	1 mm

ER16 Inch Set	ER20 Inch Set	ER25 Inch Set	ER32 Inch Set	ER40 Inch Set	<b>SETS</b>
5UMER16-SI010	5UMER20-SI009	5UMER25-SI011	5UMER32-SI014	5UMER40-SI016	<b>PART NUMBER</b>
10 Pieces	9 Pieces	11 Pieces	14 Pieces	16 Pieces	<b>NUMBER OF PIECES</b>
3/32" - 3/8" 1/16" and 13/32" not included in set	1/8" - 1/2"	1/8" - 5/8"	1/8" - 13/16"	1/8" - 1"	<b>RANGE</b>





ER Grade AA  
5 Micron Collet

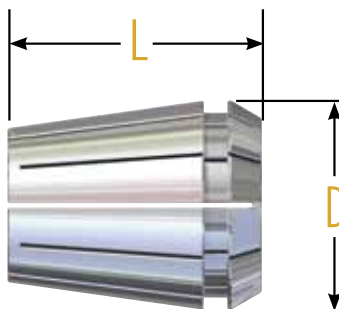

\* For specifications see page 11

## AA GRADE 5 MICRON ER PRECISION COLLETS - METRIC

PART NUMBER					Recommended Usage =/.004" (.1 mm)	Maximum Collapse Range
ER16 Metric	ER20 Metric	ER25 Metric	ER32 Metric	ER40 Metric		
5UMER16-0039					1 mm	0.5 mm
5UMER16-0078	5UMER20-0078	5UMER25-0078			2 mm	0.5 mm
5UMER16-0118	5UMER20-0118	5UMER25-0118	5UMER32-0118		3 mm	1 mm
5UMER16-0157	5UMER20-0157	5UMER25-0157	5UMER32-0157	5UMER40-0157	4 mm	1 mm
5UMER16-0196	5UMER20-0196	5UMER25-0196	5UMER32-0196	5UMER40-0196	5 mm	1 mm
5UMER16-0236	5UMER20-0236	5UMER25-0236	5UMER32-0236	5UMER40-0236	6 mm	1 mm
5UMER16-0275	5UMER20-0275	5UMER25-0275	5UMER32-0275	5UMER40-0275	7 mm	1 mm
5UMER16-0315	5UMER20-0315	5UMER25-0315	5UMER32-0315	5UMER40-0315	8 mm	1 mm
5UMER16-0354	5UMER20-0354	5UMER25-0354	5UMER32-0354	5UMER40-0354	9 mm	1 mm
5UMER16-0393	5UMER20-0393	5UMER25-0393	5UMER32-0393	5UMER40-0393	10 mm	1 mm
	5UMER20-0433	5UMER25-0433	5UMER32-0433	5UMER40-0433	11 mm	1 mm
	5UMER20-0472	5UMER25-0472	5UMER32-0472	5UMER40-0472	12 mm	1 mm
	5UMER20-0511	5UMER25-0511	5UMER32-0511	5UMER40-0511	13 mm	1 mm
		5UMER25-0551	5UMER32-0551	5UMER40-0551	14 mm	1 mm
		5UMER25-0590	5UMER32-0590	5UMER40-0590	15 mm	1 mm
		5UMER25-0630	5UMER32-0630	5UMER40-0630	16 mm	1 mm
			5UMER32-0669	5UMER40-0669	17 mm	1 mm
			5UMER32-0708	5UMER40-0708	18 mm	1 mm
			5UMER32-0748	5UMER40-0748	19 mm	1 mm
			5UMER32-0787	5UMER40-0787	20 mm	1 mm
				5UMER40-0826	21 mm	1 mm
				5UMER40-0866	22 mm	1 mm
				5UMER40-0905	23 mm	1 mm
				5UMER40-0944	24 mm	1 mm
				5UMER40-0984	25 mm	1 mm
				5UMER40-1023	26 mm	1 mm
Collet Dimension						
1.082	1.24	1.338	1.574	1.811	LENGTH (L)	
0.669	0.827	1.023	1.3	1.614	DIAMETER (D)	

ER16 Metric Set	ER20 Metric Set	ER25 Metric Set	ER32 Metric Set	ER40 Metric Set	SETS PART NUMBER
5UMER16-SM010	5UMER20-SM012	5UMER25-SM015	5UMER32-SM018	5UMER40-SM023	
10 Pieces	12 Pieces	15 Pieces	18 Pieces	23 Pieces	RANGE
1-10 mm	2-13 mm	2-16 mm	3-20 mm	4-26 mm	



**DESIGNED FOR ALL ER PRODUCTION AND PERFORMANCE COOLANT APPLICATIONS**

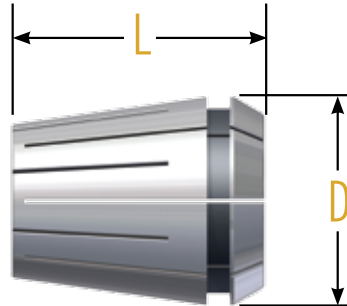

\* For specifications see page 11



**ERS Steel Sealed Collet**

**ER16-ER40 STEEL SEALED COLLETS - INCH**

PART NUMBER					
ER16 Inch	ER20 Inch	ER25 Inch	ER32 Inch	ER40 Inch	Inch Range
ERS16-0125	ERS20-0125				0.1250
ERS16-0157	ERS20-0157	ERS25-0157	ERS32-0157		0.1562
ERS16-0187	ERS20-0187	ERS25-0187	ERS32-0187		0.1875
ERS16-0218	ERS20-0218	ERS25-0218	ERS32-0218		0.2188
ERS16-0250	ERS20-0250	ERS25-0250	ERS32-0250	ERS40-0250	0.2500
ERS16-0281	ERS20-0281	ERS25-0281	ERS32-0281	ERS40-0281	0.2813
ERS16-0312	ERS20-0312	ERS25-0312	ERS32-0312	ERS40-0312	0.3125
ERS16-0343	ERS20-0343	ERS25-0343	ERS32-0343	ERS40-0343	0.3438
ERS16-0375	ERS20-0375	ERS25-0375	ERS32-0375	ERS40-0375	0.3750
ERS16-0406	ERS20-0406	ERS25-0406	ERS32-0406	ERS40-0406	0.4063
	ERS20-0437	ERS25-0437	ERS32-0437	ERS40-0437	0.4375
		ERS25-0468	ERS32-0468	ERS40-0468	0.4688
	ERS20-0500	ERS25-0500	ERS32-0500	ERS40-0500	0.5000
		ERS25-0531	ERS32-0531	ERS40-0531	0.5313
		ERS25-0562	ERS32-0562	ERS40-0562	0.5625
		ERS25-0593	ERS32-0593	ERS40-0593	0.5938
		ERS25-0625	ERS32-0625	ERS40-0625	0.6250
			ERS32-0656	ERS40-0656	0.6563
			ERS32-0687	ERS40-0687	0.6875
			ERS32-0718	ERS40-0718	0.7188
			ERS32-0750	ERS40-0750	0.7500
			ERS32-0781	ERS40-0781	0.7183
				ERS40-0875	0.8750
				ERS40-1000	1.0000

ER16 Inch Set	ER20 Inch Set	ER25 Inch Set	ER32 Inch Set	ER40 Inch Set	SETS PART NUMBER NUMBER OF PIECES RANGE
ERS16-S010	ERS20-S012	ERS25-S015	ERS32-S021	ERS40-S020	
10 Pieces 1/8-13/32	12 Pieces 1/8"-1/2"	16 Pieces 3/16"-5/8"	21 Pieces 5/32"-17/32"	20 Pieces 1/4"-1"	

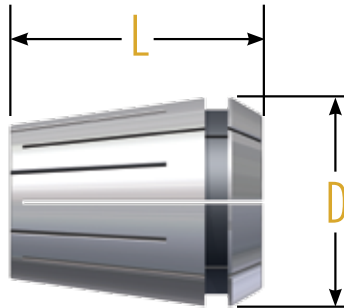

\* For specifications see page 11



ERS Steel Sealed Collet

### ERS16-ERS40 STEEL SEALED COLLETS - METRIC

PART NUMBER					Metric Range
ER16 Metric	ER20 Metric	ER25 Metric	ER32 Metric	ER40 Metric	
ERS16-0157	ERS20-0157	ERS25-0157	ERS32-0157		4 mm
ERS16-0196	ERS20-0196	ERS25-0196	ERS32-0196		5 mm
ERS16-0236	ERS20-0236	ERS25-0236	ERS32-0236	ERS40-0236	6 mm
ERS16-0275	ERS20-0275	ERS25-0275	ERS32-0275	ERS40-0275	7 mm
ERS16-0315	ERS20-0315	ERS25-0315	ERS32-0315	ERS40-0315	8 mm
ERS16-0354	ERS20-0354	ERS25-0354	ERS32-0354	ERS40-0354	9 mm
ERS16-0393	ERS20-0393	ERS25-0393	ERS32-0393	ERS40-0493	10 mm
	ERS20-0433	ERS25-0433	ERS32-0433	ERS40-0433	11 mm
	ERS20-0472	ERS25-0472	ERS32-0472	ERS40-0472	12 mm
	ERS20-0511	ERS25-0511	ERS32-0511	ERS40-0511	13 mm
		ERS25-0551	ERS32-0551	ERS40-0551	14mm
		ERS25-0590	ERS32-0590	ERS40-0590	15mm
		ERS25-0630	ERS32-0630	ERS40-0630	16 mm
			ERS32-0669	ERS40-0669	17 mm
			ERS32-0708	ERS40-0708	18 mm
			ERS32-0748	ERS40-0748	19 mm
			ERS32-0787	ERS40-0787	20 mm
				ERS40-0826	21 mm
				ERS40-0866	22 mm
				ERS40-0905	23 mm
				ERS40-0944	24 mm
				ERS40-0984	25 mm
				ERS40-1003	25 mm
				ERS40-1023	26 mm

ER16 Metric Set	ER20 Metric Set	ER25 Metric Set	ER32 Metric Set	ER40 Metric Set	SETS
ERS16-S007	ERS20-S010	ERS25-S013	ERS32-S017	ERS40-S022	
7 Pieces	10 Pieces	13 Pieces	17 Pieces	22 Pieces	<b>NUMBER OF PIECES</b>
4-10 mm	4-13 mm	4-16 mm	4-20 mm	4-26 mm	<b>RANGE</b>



**ER16-ER40 COOLANT NUT SEALS**

PART NUMBER					Metric Range	Inch Range
ER16 Metric/Inch	ER20 Metric/Inch	ER25 Metric/Inch	ER32 Metric/Inch	ER40 Metric/Inch		
CS16-0138	CS20-0138	CS25-0138	CS32-0138	CS40-0138	3-3.5 mm	.1181 – .1378
CS16-0157	CS20-0157	CS25-0157	CS32-0157	CS40-0157	3.5-4 mm	.1378 – .1575
CS16-0177	CS20-0177	CS25-0177	CS32-0177	CS40-0177	4-4.5 mm	.1575 – .1772
CS16-0197	CS20-0197	CS25-0197	CS32-0197	CS40-0197	4.5-5 mm	.1772 – .1969
CS16-0217	CS20-0217	CS25-0217	CS32-0217	CS40-0217	5-5.5 mm	.1969 – .2165
CS16-0236	CS20-0236	CS25-0236	CS32-0236	CS40-0236	5.5-6 mm	.2165 – .2362
CS16-0256	CS20-0256	CS25-0256	CS32-0256	CS40-0256	6-6.5 mm	.2362 – .2559
CS16-0276	CS20-0276	CS25-0276	CS32-0276	CS40-0276	6.5-7 mm	.2559 – .2756
CS16-0295	CS20-0295	CS25-0295	CS32-0295	CS40-0295	7-7.5 mm	.2756 – .2953
CS16-0315	CS20-0315	CS25-0315	CS32-0315	CS40-0315	7.5-8 mm	.2953 – .3150
CS16-0335	CS20-0335	CS25-0335	CS32-0335	CS40-0335	8-8.5 mm	.3150 – .3346
CS16-0354	CS20-0354	CS25-0354	CS32-0354	CS40-0354	8.5-9 mm	.3346 – .3543
CS16-0374	CS20-0374	CS25-0374	CS32-0374	CS40-0374	9-9.5 mm	.3543 – .3740
CS16-0394	CS20-0394	CS25-0394	CS32-0394	CS40-0394	9.5-10 mm	.3740 – .3937
	CS20-0413	CS25-0413	CS32-0413	CS40-0413	10-10.5 mm	.3937 – .4134
	CS20-0433	CS25-0433	CS32-0433	CS40-0433	10-5-11 mm	.4134 – .4331
	CS20-0453	CS25-0453	CS32-0453	CS40-0453	11-11.5 mm	.4331 – .4528
	CS20-0472	CS25-0472	CS32-0472	CS40-0472	11-5-12 mm	.4528 – .4724
	CS20-0492	CS25-0492	CS32-0492	CS40-0492	12-12.5 mm	.4724 – .4921
	CS20-0512	CS25-0512	CS32-0512	CS40-0512	12.5-13 mm	.4921 – .5118
		CS25-0531	CS32-0531	CS40-0531	13-13.5 mm	.5118 – .5315
		CS25-0551	CS32-0551	CS40-0551	13.5-14 mm	.5315 – .5512
		CS25-0571	CS32-0571	CS40-0571	14-14.5 mm	.5512 – .5709
		CS25-0591	CS32-0591	CS40-0591	14.5-15 mm	.5709 – .5906
		CS25-0610	CS32-0610	CS40-0610	15-15.5 mm	.5906 – .6102
		CS25-0630	CS32-0630	CS40-0630	15.5-16 mm	.6102 – .6299
			CS32-0650	CS40-0650	16-16.5 mm	.6299 – .6496
			CS32-0669	CS40-0669	16.5-17 mm	.6496 – .6693
			CS32-0689	CS40-0689	17-17.5 mm	.6693 – .6890
			CS32-0709	CS40-0709	17-5-18 mm	.6890 – .7087
			CS32-0728	CS40-0728	18-18.5 mm	.7087 – .7283
			CS32-0748	CS40-0748	18.5-19 mm	.7283 – .7480
			CS32-0768	CS40-0768	19-19.5 mm	.7480 – .7677
			CS32-0787	CS40-0787	19.5-20 mm	.7677 – .7874
				CS40-0807	20-20.5 mm	.7874 – .8071
				CS40-0826	20.5-21 mm	.8071 – .8268
				CS40-0846	21-21.5 mm	.8268 – .8465
				CS40-0866	21.5-22 mm	.8465 – .8661
				CS40-0885	22-22.5 mm	.8661 – .8858
				CS40-0905	22.5-23 mm	.8858 – .9055
				CS40-0925	23-23.5 mm	.9055 – .9252
				CS40-0944	23.5-24 mm	.9252 – .9449
				CS40-0964	24-24.5 mm	.9449 – .9646
				CS40-0984	24.5-25 mm	.9646 – .9843
				CS40-1003	25-25.5 mm	.9843 – 1.0039
				CS40-1023	25.5-26 mm	1.0039 – 1.0236



### ANTI-ROTATION GROUP

Model	Standard Group	Available Shanks	A	D	H	Option H	Pin Size	Optional Pin Size
FS90-3	TYPE 1		1.65 (41.75)	4.02 (102)	2.559 (65)	3.149 (80) 4.330 (110)	18 mm	28 mm with 110 mm H only
FS90-3L								
FS90-4								
FS90-4L								
F90-07								
F90-07L								
F90-10								
F90-10L								
FMU-10								
FR90-10								
F90-16S								
FMU-16								
F90-16		Type 2						
F90-16L								
FR90-16								
F90-20								
FMU-20	Type 3	Cat 50		6.18 (157)	4.330 (110)		28 mm	
FR90-20								
F90-30D*								

\* Type 2 available on request



# STOP-BLOCK type 1-2



Standard stop block provided with each head.

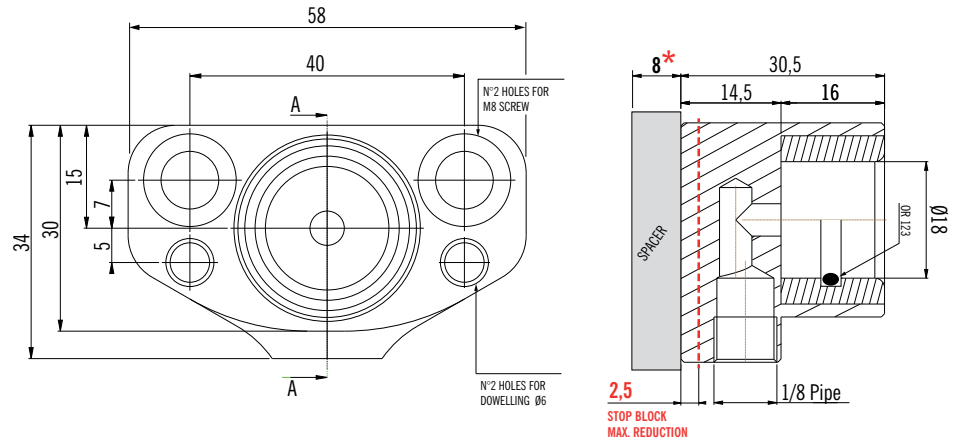

NOTE 1: \* 8 mm spacer thickness is reference only. Please refer to following pages for application calculations.

# STOP-BLOCK type 3

For Angle Heads type F90-S40 / F90-S40-70BAR 7 FMU 20



Standard stop block provided with each head.

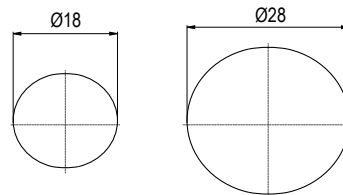
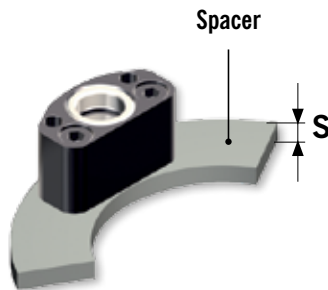
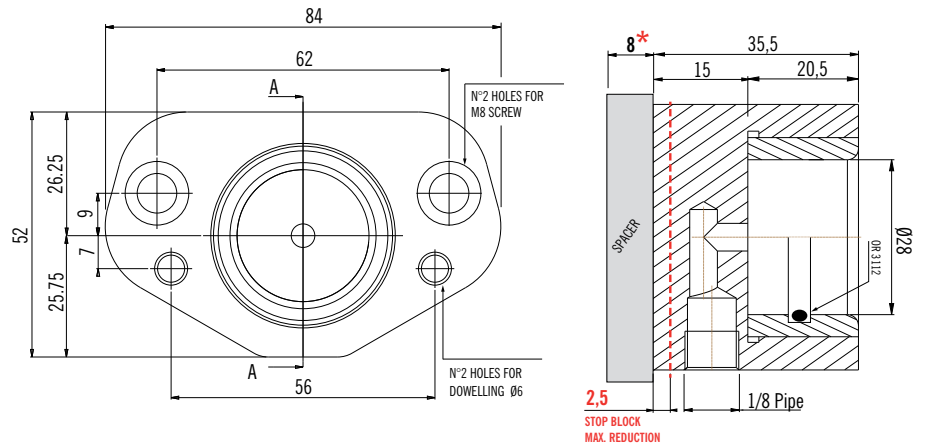

Elliptical Positioning Pin allows for single or multiple head applications

Note 2: Optional spacer is not provided. "S" thickness is for reference only. Actual thickness, and/or the need for a spacer can be calculated on the following pages.





### CHECK SUITABILITY OF THE MACHINE TOOL SPINDLE TO MOUNT A STOP BLOCK.

#### If stop block is already mounted on the machine tool

1. Check the bushing diameter in the stop block (18mm or 28mm)
2. Calculate the "A" dimension based on the shank choices in the chart.  
Note "B" is calculated from Spindle Gauge Line

#### If no stop block is mounted on the machine spindle

1. The standard positioning pin is OK and it will be necessary to make a spacer if dimension X is larger than the values indicated in table 1.
2. The positioning pin must be shortened if dimension X is included between values indicated in table 1 (Max shortening 8mm with angle heads type 1 & 2, Max 6,5mm with angle heads type 3).
3. It will be necessary for a special positioning pin if dimension X is less than the values indicated in table 1.

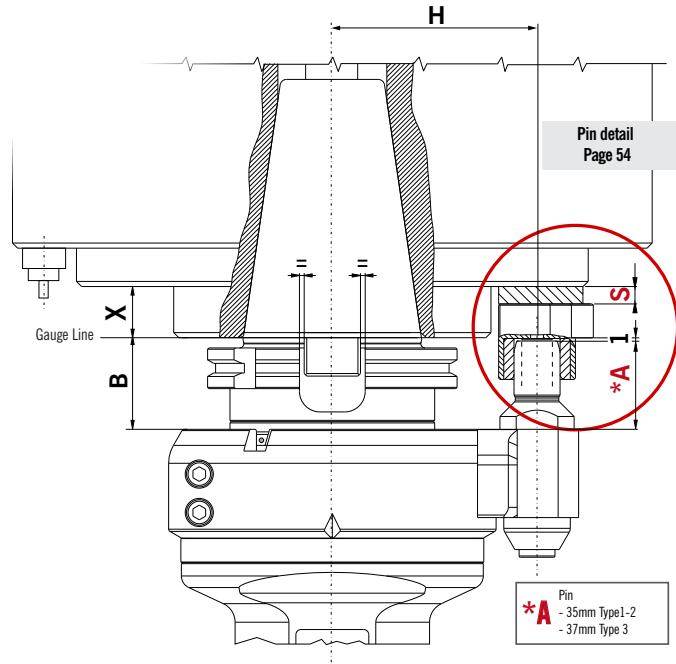

**TABLE 1 - STANDARD** 35mm (type 3 = 37mm)

SHANKS	B	X	"S" CALCULATION FOR SPACER THICKNESS	
			H	S
SK-CAT-BT30 SK-CAT-BT40 SK-CAT50	35	$X \geq 23,5\text{mm}$	$H = 65/80/110 - \varnothing18$	$S = X - 15,5\text{ mm}$
			$H = 110 - \varnothing28$	$S = X - 16\text{ mm}$
	37	$X \geq 24\text{mm}$	$H = 65/80/110 - \varnothing18$	$S = X - 7,5\text{ mm}$
			$H = 110 - \varnothing28$	$S = X - 8\text{ mm}$
BT50	43	$X \geq 15,5\text{mm}$	$H = 65/80/110 - \varnothing18$	$S = X - 6,5\text{ mm}$
			$H = 110 - \varnothing28$	$S = X - 7\text{ mm}$
	45	$X \geq 16\text{mm}$	$H = 65/80/110 - \varnothing18$	$S = X - 6,5\text{ mm}$
			$H = 110 - \varnothing28$	$S = X - 7\text{ mm}$
HSK-63	44	$X \geq 14,5\text{mm}$	$H = 65/80/110 - \varnothing18$	$S = X - 4,5\text{ mm}$
			$H = 110 - \varnothing28$	$S = X - 5\text{ mm}$
	46	$X \geq 15\text{mm}$	$H = 65/80/110 - \varnothing18$	$S = X - 4,5\text{ mm}$
			$H = 110 - \varnothing28$	$S = X - 5\text{ mm}$
HSK-80 HSK-100	46	$X \geq 12,5\text{mm}$	$H = 80/110 - \varnothing18$	$S = X - 4,5\text{ mm}$
			$H = 110 - \varnothing28$	$S = X - 5\text{ mm}$
	47	$X \geq 13\text{mm}$	$H = 80/110 - \varnothing18$	$S = X - 4,5\text{ mm}$
			$H = 110 - \varnothing28$	$S = X - 5\text{ mm}$

#### SHORTENED $S = 8\text{ mm}$

X	"A" HEIGHT PIN CALCULATION	
	H	S
$24 > X > 16,5\text{ mm}$	$A = (X+B) - 23,5$	
	$A = (X+B) - 24$	
$16 > X > 8,5\text{ mm}$	$A = (X+B) - 23,5$	
	$A = (X+B) - 24$	
$15 > X > 7,5\text{ mm}$	$A = (X+B) - 23,5$	
	$A = (X+B) - 24$	
$13 > X > 5,5\text{ mm}$	$A = (X+B) - 23,5$	
	$A = (X+B) - 24$	

#### SPECIAL

X
$X < 16,$
$16 > X > 8,5\text{ MM}$
$15 > X > 7,5\text{ MM}$
$13 > X > 5,5\text{ MM}$

See spacer calculation example Page 55



**CHECK SUITABILITY OF THE MACHINE TOOL SPINDLE TO MOUNT A STOP BLOCK.**

Check pitch "H" through table 2

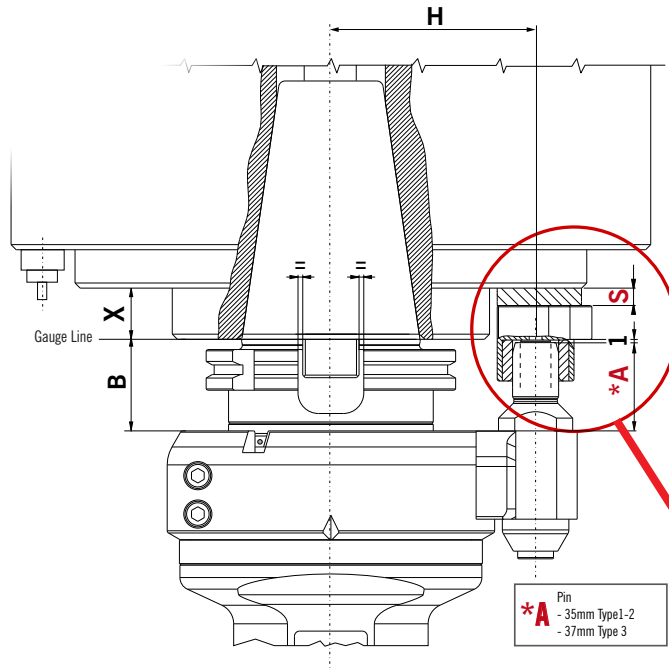

**TABLE 2**  
Max Machine Spindle Diameter for Standard Pitch

Pin	"H" Pitch	Ø Max
Ø18	65	Ø99
	80	Ø129
Ø28	80	Ø106
	110	Ø166

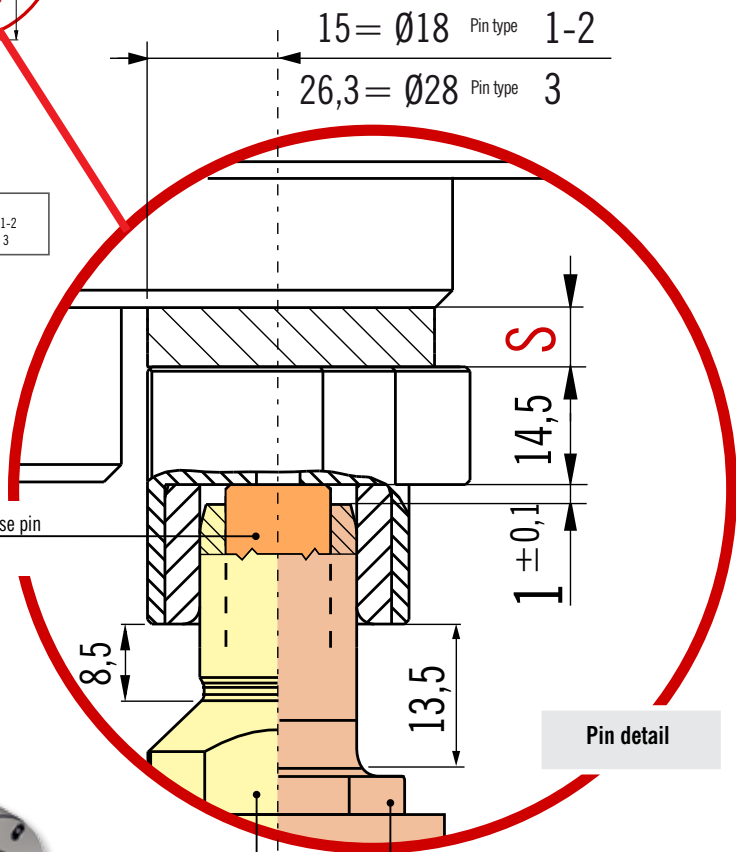

**ATTENTION!**

The calculation for the location of the stop block must be done to allow 1 mm of free play remaining in the release pin travel. This will ensure that the anti-rotation system is free to rotate without deflection caused by fixed length anti-rotation pin contact of the bottom of the stop block.

**EXAMPLE OF CALCULATION FOR SPACER THICKNESS**

$X = 23,5\text{mm}$	$B = 35\text{mm (SK40)}$
$S = X (23,5) - 15,5 = 8$	

**N.B:**

**23,5** is also the minimum X to use the standard pin

**8** is the spacer thickness





### ANGLE HEADS

### SHANK GROUP

### FLANGE

### EXTENSION

MODEL	TYPE	Cod.	DRAWINGS	Cod.	H	Cod.
F90-16S	1	9.SK30.MTC		9.FL.F90T1	100	9.FEX.10100
		9.SK40.MTC			200	9.FEX.10200
		9.SK50.MTC				
		9.CT40.MTC				
		9.CT50.MTC				
F90-16L F90-20	2	9.BT40.MTC		9.FL.F90T2	100	9.FEX.20100
		9.BT50.MTC			200	9.FEX.20200
		9.HSK63.MTC				
		9.HSK80.MTC				
		9.HSK100.MTC				
F90-S40	3	9.C5.MTC		9.FL.F90T3	100	9.FEX.30100
		9.C6.MTC			200	9.FEX.30200
		9.C8.MTC				
		9.KM63.MTC				
		9.KM80.MTC				
F90-S50	4	9.KM100.MTC		9.FL.F90T4	300	9.FEX.40300
		9.208040.MTC			-	-
		9.208050.MTC			-	-
		9.208050.MTC			-	-

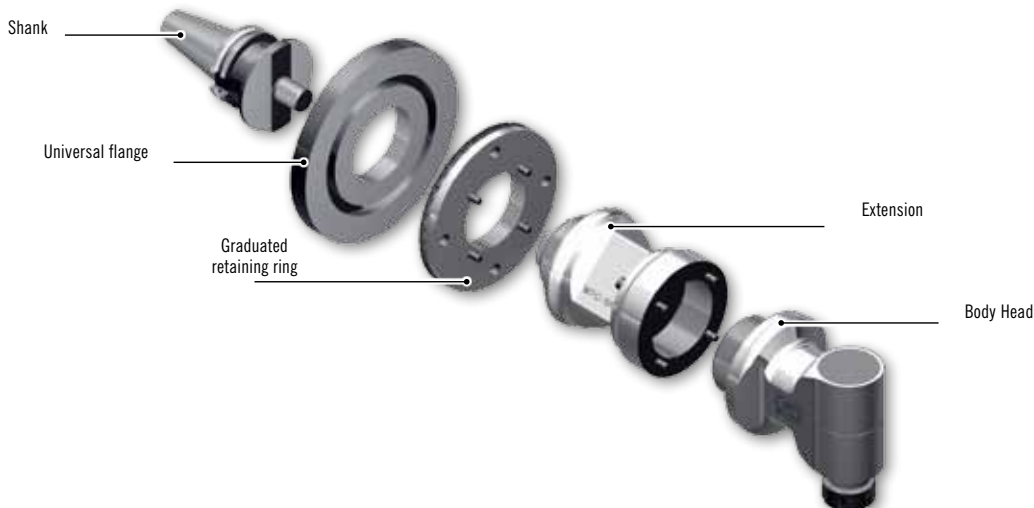

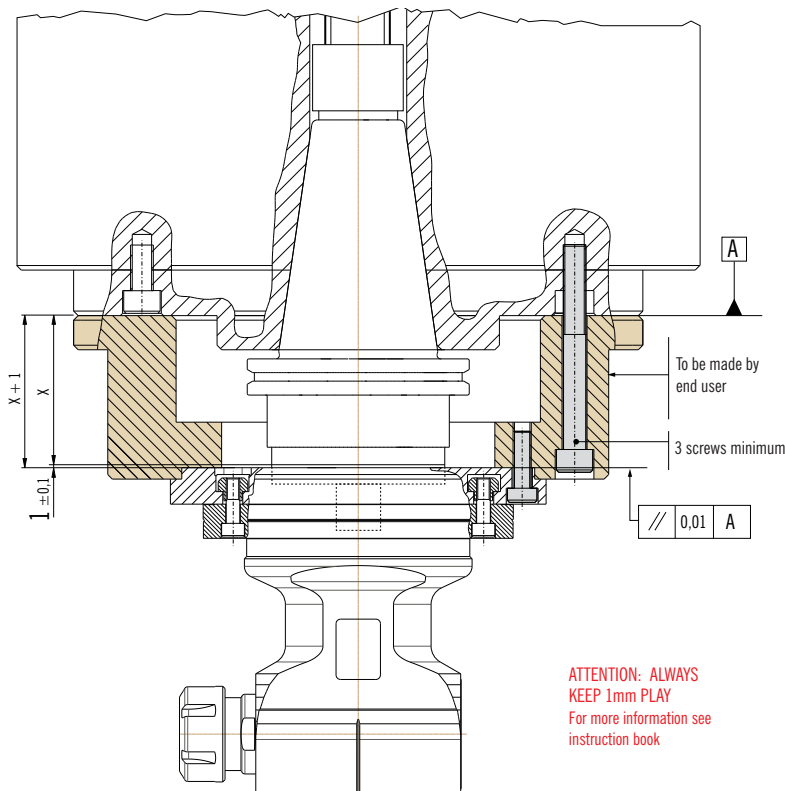
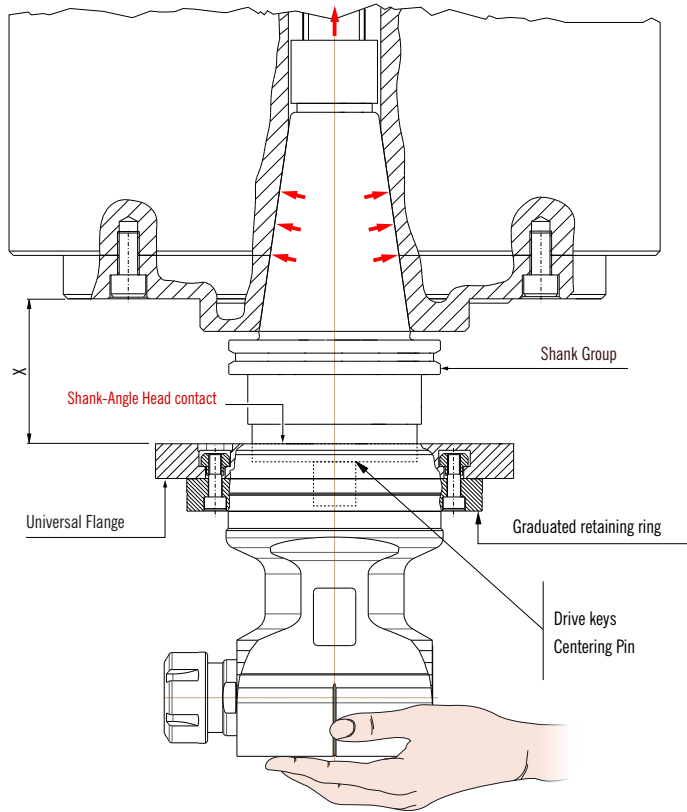

### STEP 1

- Assemble the shank on the machine through the machine spindle
- Assemble the universal flange on the head
- Position the head ensuring the contact shank-angle head body
- Check dimension "X"



### STEP 2

- Make a spacer with  $X + 1$ mm thickness to be mounted between universal flange and machine spindle
- Use 3 screws minimum



## CONTACT INFORMATION

For quick response, just photocopy this page, complete all information (please include Part Print where appropriate) and simply FAX back to Parlec at 1-800-866-5917

Date \_\_\_\_\_

\*Name \_\_\_\_\_

Address \_\_\_\_\_

Province \_\_\_\_\_

\*Country \_\_\_\_\_

\*Email \_\_\_\_\_

\*Company \_\_\_\_\_

City \_\_\_\_\_

Zip Code \_\_\_\_\_

Phone \_\_\_\_\_

### \*Activity:

- End User
- Distributor
- Machine Builder
- Machine Tool Dealer

## MACHINE INFORMATION

Machine Make \_\_\_\_\_

Machine Model \_\_\_\_\_

\*Tool Changer:  Automatic  Flange Mount

\*Tool Changer Weight Capacity: kg \_\_\_\_\_

Choose a surface for stop block:  K  Y  Z

X= \_\_\_\_\_

Distance between gauge line and surface for stop-block

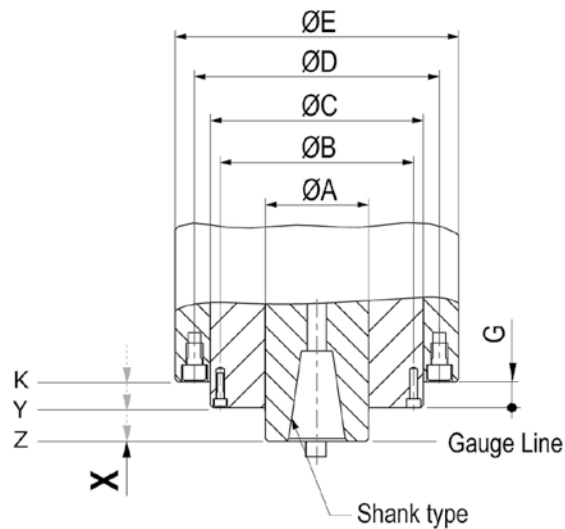

ØA: \_\_\_\_\_ ØB: \_\_\_\_\_ ØC: \_\_\_\_\_ ØD: \_\_\_\_\_ ØE: \_\_\_\_\_ G: \_\_\_\_\_

## APPLICATION INFORMATION

Application:  Milling End Mill Diameter and Flute: \_\_\_\_\_  Drilling & Tapping

Material: \_\_\_\_\_ Hardness: \_\_\_\_\_

RPM: \_\_\_\_\_ Feed Rate: \_\_\_\_\_ Depth of Cut: \_\_\_\_\_ Width of Cut: \_\_\_\_\_

Notes: (For a thorough study of the application send: drawing of the part to work, drawing tool, etc...)



### ANGLE HEAD INFORMATION

\*Head Style:  Fixed 90°  0°-90° Adjustable  Special Fixed Angle  Dual Output  Automatic Tool Change  Flange Mount

\*Output Toolholder: \_\_\_\_\_ \*Dimension: \_\_\_\_\_

Internal Coolant Required Pressure: \_\_\_\_\_

Through Orientation Pin

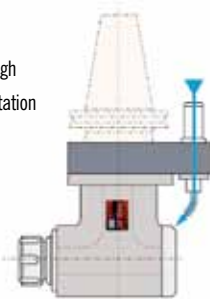

Through Orientation Pin and Tool

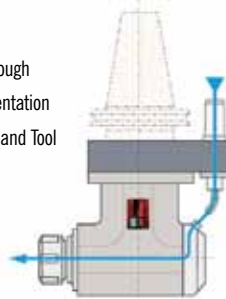

Directly from the Machine Spindle through the Tool

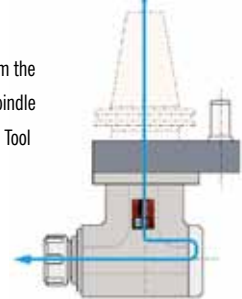

### ANGLE HEAD DIMENSIONS

A: \_\_\_\_\_ B: \_\_\_\_\_ C: \_\_\_\_\_ D: \_\_\_\_\_

E: \_\_\_\_\_ E1: \_\_\_\_\_ E2: \_\_\_\_\_ E3: \_\_\_\_\_

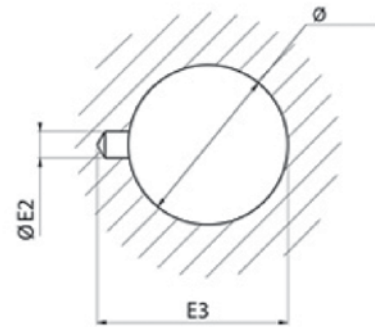
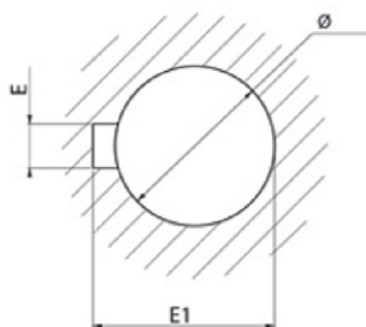
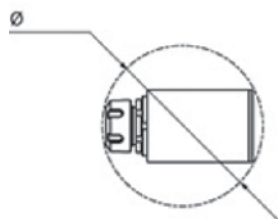
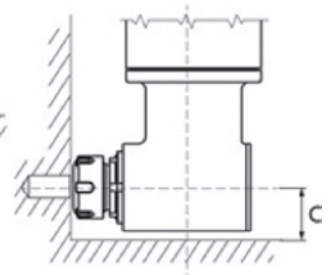
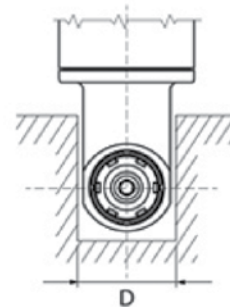
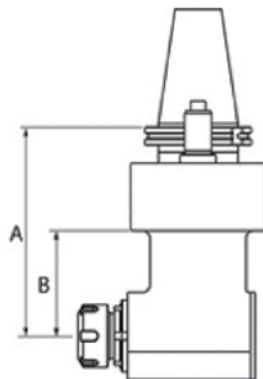





Notes

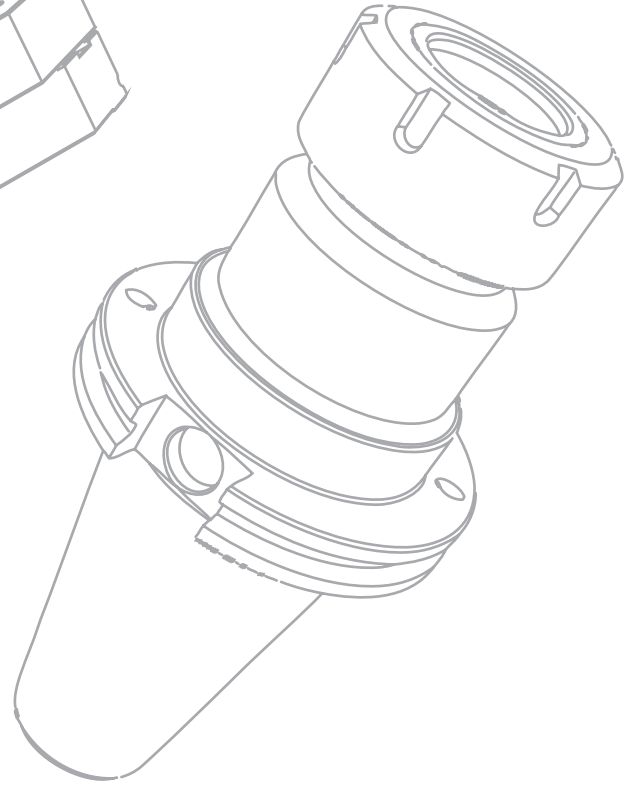
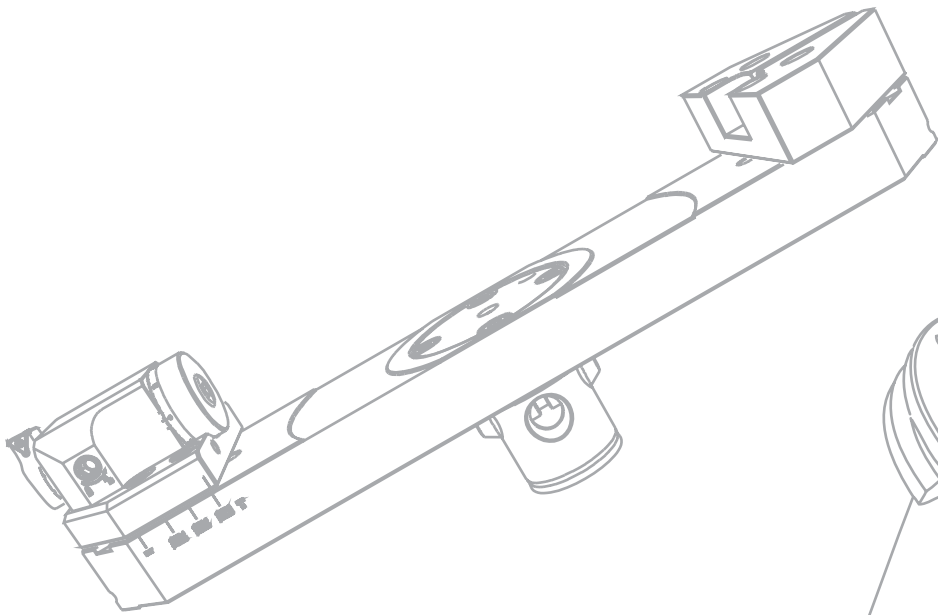

**PARLEC**

TOOLHOLDING • TAPPING • BORING • PRESETTING

Visit Us Online [www.parlec.com](http://www.parlec.com)

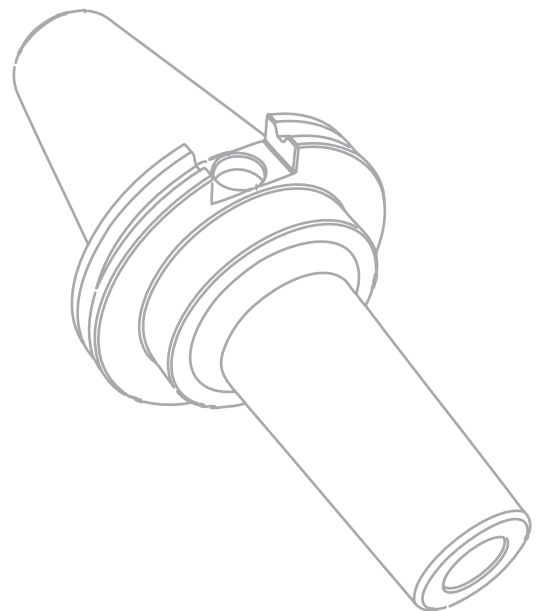
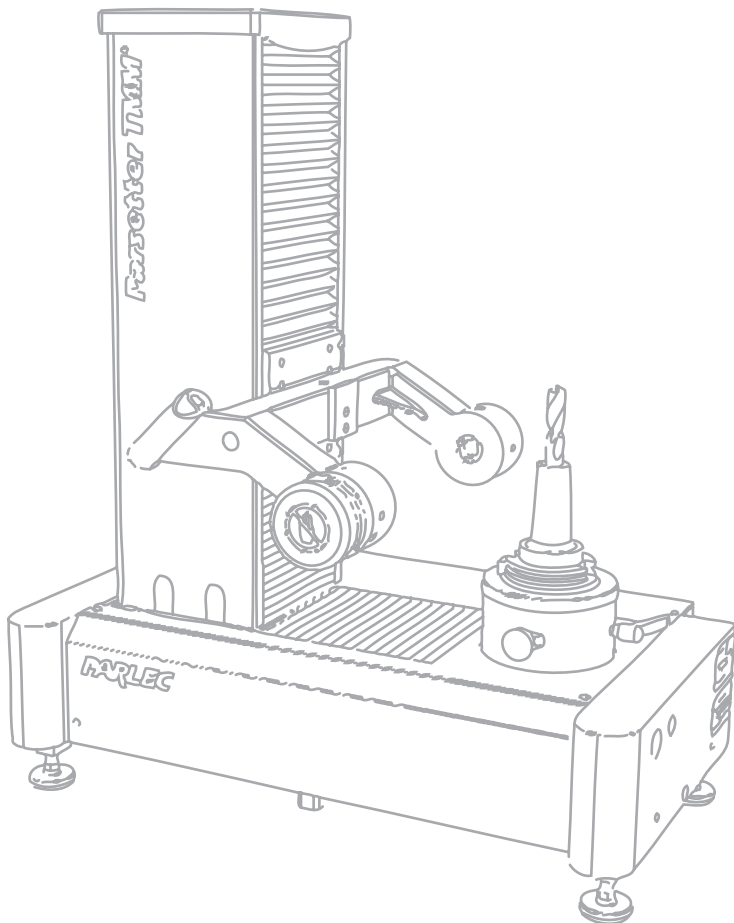



**PARLEC** | BY ANY MEASURE  
Measurably Better



COMPLETE  
METALWORKING  
SOLUTIONS

(800) 991-4225  
www.ahbinc.com  
ISO Certified  
customerservice@ahbinc.com

**Asia Pacific**

Tel: 86-25-8711-3188  
Fax: 86-25-8711-3180

**Europe**

Tel: 01-585-425-4400  
Fax: 01-585-425-7542

**Headquarters**

101 Perinton Parkway  
Fairport, NY 14450 USA

