

RSVP TOOLING

Product Catalog

AHB

TOOLING & MACHINERY

COMPLETE METALWORKING SOLUTIONS

(800) 991-4225

www.ahbinc.com

ISO Certified

customerservice@ahbinc.com



Welcome To The RSVP Tooling Interactive Catalog

Clickable & Touch Links

Within each page we have included a wide range of links that can be click when viewed on a computer or touched on a smart device (phones and pads).

The side tabs to the left when click will return you to the section index.

On the master index and section indexes the line items also contain links to the indicated pages.

Tangential Index	70
Attachments	71
Thread Rolls & Settings Gauges.....	72
Design of Rolls	73
RT10 - RT20 - RT30 Overview & Components	74 - 75
Tangential Charts	76 - 77

Icon Links



Click this icon to follow and like RSVP Tooling on FaceBook. Get the most up-to-date information on products, training, videos and products for your smart devices.



Click this icon to follow our short RSVP tweets. Quick tips and helpful links to increase your threading quality and productivity.



Click this icon to expand your network of professional contacts.



Click this icon to visit our video channel. When this icon is next to a product you can directly link to a demonstration video.



Click this icon to quickly access our extensive knowledge base within the RSVP Tooling website.



Click this icon to return to the main index of this catalog.



Click this icon to return to the section index for that product or page.

Downloading this catalog to a smart device

This catalog can be viewed on smart devices such as phones and pads. Most free PDF viewers will allow you to flip from page to page.



However, if you would like to take advantage of the built in interactive features you will need to download an app.

We have reviewed many apps and have found that ezPDF Reader seems to work the best on both the Apple and Droid product lines. It is available in two forms - one for the pads and one for the phones.



Start by going to your apps download center on your device. Search for "ezPDF Reader" and look for the above icon. Purchase the app that matches your device. Download and activate the app.

Follow the instructions to download a file to the app. Select "URL Download" and enter the following - "http://www.rsvptooling.com/RSVPcatalog.pdf". Once the catalog is loaded you can start using the interactive features.



World Class Threading Tools

About RSVP . . .

RSVP Tooling is a leading supplier of high production external threading tools. From our facility in Joliet Illinois, we distribute the widest range of thread cutting dieheads, chasers, thread rolling attachments and thread rolls in North America. Our comprehensive inventory is supported by our dedicated 20,000 sq. ft. manufacturing division in the UK, where 60 years of threading tool production, combined with the latest CNC technology, enable us to design and deliver solutions for virtually any threading application.

World Class Products

The RSVP range of thread cutting and thread rolling tools is the most extensive in North America:

RSVP dieheads: our "Namco style" dieheads have long been recognized as the ultimate thread cutting system. The concept of the circular chaser, able to produce accurate threads in a single pass still has no equal in terms of performance and cost per part.

RSVP chasers: in addition to circular chasers, we also supply a wide range of precision ground chasers for use on geometric style dieheads.

RSVP thread rolling: recognized as the fastest method of producing strong, accurate threads and a requirement for safety critical parts in the aerospace and automotive industries. Our extensive range of attachments and rolls are particularly suited for use on virtually any type of machine.

First Class Service

Our in depth knowledge of threading tools, how they are made and the machines they are used on is a highly valued resource and freely accessible to customers throughout North America. We offer service and repair of all types of threading attachments with new and surplus parts available on site.

Affordable Alternatives

RSVP Tooling maintains a vast array of used, rebuilt and surplus equipment on site for situations where short run, budget or compatibility constraints require special attention. Call anytime for assistance with your needs.

Specialized Applications

We have partnered with expert tool manufacturers to provide complete solutions for the most complex applications. The need for complete tooling packages has expanded our product offering and knowledge base over the years enabling us to adapt our tooling to the most current demands.



Circular Chaser System

The Circular Chaser shape allows for the chaser to be ground through a full 270 degrees, which makes the circular style chaser by far, the system with the longest tool life over all other threading systems. The circular shape of the cutter permits only enough rubbing action immediately behind the cutting edge to ensure proper lead control. This eliminates excessive rubbing and assures smoother threads and longer chaser life. In addition, the chasers body mass and external mounting provides a faster dissipation of heat away from the work, frees chips for faster cutting speeds and allows the ability to cut up close to the shoulder of a part. RSVP Tooling's exclusive modular shank dieheads provide the ability to choose the specific shank adapter suitable for your machine or for use in multiple machines. The shank adapter option also minimizes cost associated with shank replacement due to common wear and use.

Circular Chaser Index	4
Circular Chasers Advantages	5
DR - Overview & Components	6
DRF - Overview & Components	7
DRD - Overview & Components	8
DS - Overview & Components	9
DSF - Overview & Components	10
DBS - Overview & Components	11
DRSA - Overview & Components	12
DRSA-Biltz - Overview & Components	13
DRFSA - Overview & Components	14
Custom Circular Chaser Heads	15
Special Circular Chaser Services	15
Oversized Circular Chaser Heads	15
Stock Modular Shanks	16 - 18
DR61 Chaser Screws Component Parts	19
Serrated Bushing Chart DR63	19
Grinding Accessories	20
Circular Chasers & Blocks Charts	21 - 22
How To Order Circular Chasers	22

Geometric

Geometric or insert style chaser heads provide an affordable alternative to other systems when short run jobs and intermittent use are necessary. RSVP Tooling offers several variations to choose from that can be tailored to virtually any application. Standard stationary "self-opening" as well as solid adjustable and acorn die replacement models are offered for use in almost any type of machine. Any of the options available can also be made specific to your requirements.

Geometric Chaser Index	23
D-Style - Overview & Components	23 - 24
DJ - Overview & Components	25
SAMN - Overview & Components	26
SAMAN - Overview & Components	27
Geometric Chaser Specs & Terms	28 - 29
How To Order Geometric Chasers	29

Axial

For producing long threads, or threads without run-out restriction, RSVP axial rolling heads are the ideal selection. Axial heads feed on from the end of the part and require one revolution of the spindle for each pitch of thread to be produced. Controlled forward axial motion, either by cam or CNC feed, are recommended although manually operated lathes can also give excellent results. RSVP axial heads are self opening and require an external closing mechanism to reset them. Right hand rolling heads are required for rolling right hand threads and the spindle direction must also be right hand. Left hand threads require corresponding heads and spindle rotation.

Axial Thread Rolling Index / How To Order	30
RSVP Thread Rolling System Advantages	31
Thread Rolling Introduction	32
Applications	33
A0 - Overview & Components	34
A001 - Overview & Components	35
A01 - Overview & Components	36
A1 - Overview & Components	37
A12 - Overview & Components	38
A2 - Overview & Components	39
A23 - Overview & Components	40
A233400 - Overview & Components	41
A3 - Overview & Components	42
A34 - Overview & Components	43
A4 - Overview & Components	44
A45 - Overview & Components	45
A5 - Overview & Components	46
A56 - Overview & Components	47
Operation	48 - 50
Problem Solving	51
Lead Angles	52 - 54
Recommended Blank Diameters	55 - 57
Rolling Speeds	58

Radial

RSVP Radial rolling heads offer an ideal solution for producing very short threads with tight runout, rolling close to a shoulder or into an undercut. Due to the 3-roll action of the radial system, the component is well supported during the rolling process, even when threading the ends of long shafts. Since the rolling action is completed within one revolution of the rolls, cycle times are extremely short and in most cases, under 0.5 seconds. Radial rolling heads are automatically reset after each threading pass, but are normally actuated by means of the external trip lever on stationary heads, or an internal push rod on rotating heads.

Radial Thread Rolling Index	59
Radial Thread Rolling Operation	60
RE-8 - Overview & Components	61
RE-10 - Overview & Components	62
RE-13 - Overview & Components	63
RE-16 - Overview & Components	64
RE-23 - Overview & Components	65

Tangential

This system is used mainly on bar lathes for rolling short threads close to the shoulder or behind the shoulder. The tangential attachment is fitted to the machine cross slide and under controlled feed, forces the rolls tangentially over the rotating part up to its center line. Unlike axial heads, tangential rolling heads do not have the ability to traverse along the part to produce a thread. Therefore thread length is limited to the maximum thread roll width for the head used. Tangential attachments can roll both right and left hand threads with spindle rotation in either direction. Only the roll design is changed.

Tangential Thread Rolling Index	66
Attachments	67
Thread Rolls & Setting Gauges	68
Design of Rolls	69
RT10 - Overview & Components	70
RT20 - Overview & Components	71
RT30 - Overview & Components	72
Tangential Thread Roll Charts	73
Custom Tangential Thread Rolls	74

Spline

We offer job specific synchronized spline rolling heads to suit nearly any application.

The 3 roll design is offered in two styles engineered to meet your specification. A spring loaded retractable style for shorter parts and an external three roll synchronized design for longer parts are available.

Our Spline Rolling heads are the industry standard for accurate repeatability and reliable performance for virtually any size part and particularly useful for large run jobs.

RS Spline Rolling Head	75
------------------------------	----

Zeus Knurling & Marking Tools

RSVP Tooling is the exclusive North American distributor for Zeus Knurling and Marking tools. German engineering and precision manufacturing qualify these tools as the best high precision option available. Our partnership affords unbeatable design support to meet any requirement.

For further information please ask for our knurling or marking specific catalogs or go to www.hommel-keller.com to view the most current information available.

Zeus Cut Knurling Tools	76
Zeus Form Knurling Tools	77
Zeus Marking Tools	78

Specialty Tools

RSVP Tooling has partnered with precision tool holding manufacturers to provide complete set up solutions to adapt our tooling to any application.

Please contact us with your needs and we can use our many resources to provide an economic and custom engineered solution for you.

Baublies Precision Roller and Diamond Burnishing tools	79
Specialty Toolholders	80

CIRCULAR CHASER System

Here's how RSVP's Circular Chaser System offers the longest tool life over all other threading systems.

- Circular Chaser shape allows for the chaser to be ground through a full 270 degrees.
- Shape of the cutter permits minimal rubbing action immediately behind the cutting edge to ensure proper lead control eliminating excessive rubbing for smoother threads and longer chaser life.
- Chasers body mass and external mounting provides a faster dissipation of heat away from the work, frees chips for faster cutting speeds, and allows for the ability to cut up close to the shoulder of a part.
- Replaceable plunger wear groove inserts extend the life of the cutting head.

This system is designed for maximum tool usage and life that allows for increased productivity which saves you more money.

Circular Chasers Advantages.....	5
DR - Overview & Components	6
DRF - Overview & Components	7
DRD - Overview & Components.....	8
DS - Overview & Components	9
DSF - Overview & Components	10
DBS - Overview & Components	11
DRSA - Overview & Components.....	12
DRSA-Biltz - Overview & Components	13
DRFSA - Overview & Components	14
Custom Circular Chaser Heads	15
Special Circular Chaser Services	15
Oversized Circular Chaser Heads	15
Stock Modular Shanks	16 - 18
DR61 Chaser Screws Component Parts.....	19
Serrated Bushing Chart DR63.....	19
Grinding Accessories	20
Circular Chasers & Blocks Charts	21 - 22
How To Order Circular Chasers	22



CIRCULAR CHASER Advantages

Shape:

The circular shape of the cutter permits only enough rubbing action immediately behind the cutting edge to ensure proper lead control. This eliminates excessive rubbing and assures smooth threads and longer chaser life. In addition, the chasers body's mass and external mounting provides a faster dissipation of heat away from the work and frees chips for faster cutting speeds.

Sustained Accuracy:

The user is assured that with an RSVP diehead and one set of chasers, precision threads will cut immediately without trial and error method of switching chaser sets. The thread forms of the circular chaser are annular. The helix angle is ground into the face of the holding block at the factory and remains for the life of the tool.

Grinding:

The circular chaser can be re-ground through a full 270 degrees. Compare this basic advantage with others that have thin blades resulting in short chaser life. The circular tool is the simplest and easiest of all to grind with positive accurate results. The throat grind is built in the chaser form and does not change as the chaser is re-sharpened through the entire 270 degrees.

Replacement:

The preset nature of the chaser mounted on the block and precisely ground, assures quick installation. The removal and replacement is done in seconds, as compared to minutes in other styles without disturbing the setup. This is accomplished by a simple turn of a screw on some heads or lifting and turning of the reset handle on others.

Interchangeability:

All circular tools may be interchanged from rotating to non-rotating heads, size for size. The circular chaser's extreme versatility is demonstrated by its ability to machine a wide range of material by changing the grind to a precise, predetermined setting, bringing the cutting edge up to the proper position for the material used.

Modular Shanks:

This is a feature you will only find exclusively offered on RSVP's circular chaser systems. Modular Shanks offer greater tooling flexibility as the same head can be used on

various machines by changing shanks which leads to reduced tool inventory and improved tool utilization. This allows for easier handling and less down time which saves you time and money. These shanks are available in standard and coolant induced in a wide range of sizes. See pages: 16 - 18

4-Chaser Dieheads:

Provide the economy of operation, high production and accuracy required making them a true asset to the industry. Their range of size and interchangeability point to one fact; no other threading tool possesses the versatility of RSVP Tooling dieheads. RSVP Tooling's exclusive modular shank dieheads provide the ability to choose the specific shank adapter suitable for your machine or for use in multiple machines. The shank adapter option also minimizes cost associated with shank replacement due to common wear and use.

5-Chaser Dieheads:

Have been developed to cover industry's increasing need to meet higher material specifications and improved gauging methods (such as tri-roll). Due to the rigid 5-point contact between tooling and workpiece, 5-chaser threading is the solution when applied to work pieces having flats, keyways, slots, drilled holes due to the elimination of perpendicular offset between chasers common with 4 chaser heads. Improved roundness is also obtained. The advantages gained and economics achieved when using RSVP tooling 5-chaser dieheads easily outweigh the slightly additional cost. RSVP Tooling's exclusive modular shank dieheads provide the ability to choose the specific shank adapter suitable for your machine or for use in multiple machines. The shank adapter option also minimizes cost associated with shank replacement due to common wear and use.

Plunger Wear Insert:

All RSVP circular chaser dieheads are fitted with a replaceable plunger wear insert in the diebody.

Previous designs have the plunger groove machined directly into the body of the head. Once the localized area of plunger contact is worn to the point of the diehead not locking closed in operation it would be necessary to replace the diebody at a considerable expense.

Our replaceable hardened inserts offer a simple affordable alternative. Simply replace the worn insert at minimal cost, thus conserving the more expensive diebody for continued use.

DR Yoke Operated for Revolving Spindles

The style DR diehead is for use on machines having a revolving spindle. The head is extremely rugged and suitable for either right hand or left hand threads. Opens and closes by means of external yoke spool. Chasers are interchangeable with those of DS, DBS and DRD dieheads of the same capacity. Chasers for hollow milling are also available.

See pages 16 - 18 for available shank options.



DR Circular Chaser Head Dimensions

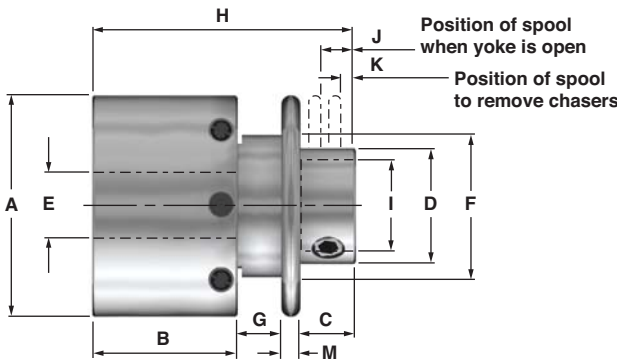

EDP	Size of Diehead	Straight Threads Inches	A	B	C	D	E	
7081	5/16	.056-312	IN.	1.94	1.31	1.77	0.75	0.38
7082	3/8	.188-.375	IN.	2.63	1.72	1.08	1	0.56
7084	9/16	.250-.562	IN.	2.88	1.88	0.71	1.5	0.63
7091	13/16	.250-.562	IN.	3.63	2.06	0.8	1.5	0.88
7087	1	.250-.812	IN.	4.06	2.25	0.8	1.5	1.06
7088	1-1/16	.375-1.000	IN.	3.88	2.06	0.8	1.5	1.13
7083	1-5/8	.500-1.062	IN.	4.88	2.25	0.92	2.75	1.69
7090	2	.500-1.625	IN.	5.13	2.25	0.92	2.75	1.75

EDP	Size of Diehead	F	G	H	I	J	K	M
7081	5/16	1.38	0.38	3.08	0.33	1.58	1.4	0.13
7082	3/8	1.38	0.38	2.8	0.56	0.86	0.49	0.18
7084	9/16	1.84	0.56	2.59	0.93	0.49	0.05	0.24
7091	13/16	1.94	0.56	2.86	0.93	0.46	0.05	0.24
7087	1	2	0.56	3.05	1.1	0.49	0.05	0.25
7088	1-1/16	2	0.56	2.86	1.1	0.46	0.05	0.24
7083	1-5/8	3.5	0.75	3.17	1.1	0.58	0.05	0.25
7090	2	3.5	0.75	4.16	1.75	0.58	0.05	0.25

Component Parts Breakdown

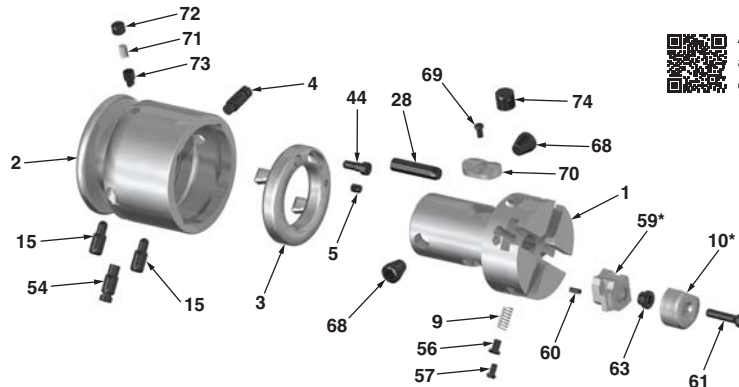

A larger version of this parts breakdown is available at - www.rsypooling.com/prints.html or by scanning this QR code.

Part#	Unit Description	EDP Req'd	5/16" EDP No.	3/8" EDP No.	9/16" EDP No.	13/16" EDP No.	1" EDP No.	1-1/16" EDP No.	1-5/8" EDP No.	2" EDP No.
DR-1A	Body assembly	1	2960M	2957M	2992M	2911M	2909M	2916M	2919M	2928M
DR-2A	Cup assembly	1	2961	2958	2951	2912	2910	2917	2920	2929
DR-3A	Adjusting plate assembly	1	2962	2959	2952	2913	2907	2918	2921	2930
DR-4	Retaining screw	1	0	3024	3023	3028	3087	3074	3028	3087
DR-5	Stop pin in DR-3A	1	3021	3025	3025	3029	3029	3029	3209	3029
DR-9	Chaser spring	4	3218	3226	3233	3239	3244	3239	3244	3244
DR-9HD	Chaser spring/HD	4	3195	3233	3227	3250	3240	3250	3240	3240
DR-15	Adj Screw in DR-2A	2	3156	3026	3022	3030	3027	3030	3031	3031
DR-28	Guide pin in DR-3A	1	3174	3171	3164	3099	3100	3099	3157	3157
DR-44	Adjusting plate screw	1	3035	3036	3036	3037	3037	3037	3037	3038
DR-54	Chaser locking screw	1	3020	3043	3042	3044	3163	3074	3044	3163
DR-56	Spring plunger for DR-9	4	3073	3080	3080	3080	3046	3080	3046	3046
DR-57	Spring plunger screw	4	3045	3045	3045	3045	3045	3045	3045	3045
DR-60	Pin in block	4	3071	3247	3247	3247	3247	3247	3255	3255
DR-61	Chaser screw	**	**	**	**	**	**	**	**	**
DR-63	Serrated brushing	**	**	**	**	**	**	**	**	**
DR-68	Shank Locking Scrw	2	N/A	N/A	1419	1419	1419	1419	1419	1419
DR-69	Groove Insert Screw	1	N/A	N/A	1420	1420	1420	1420	1420	1420
DR-70	Plunger Groove Insert	1	N/A	N/A	100	101	102	101	103	114
DR-71	Spring for DR-73	1	3143	3197	3220	3228	3228	3228	3246	3228
DR-72	Ret screw for DR-73	1	3147	3263	3152	3201	3201	3201	3201	3201
DR-73	Die cup plunger	1	3159	3161	3161	3153	3153	3153	3153	3153
DR-74	Float bushing assembly	1	2953	2953	2953	2908	2908	2908	2922	2922

* See pages 21-22 for available standard block and chaser sizes.

** See Page 19

DRF Yoke Operated for Revolving Spindles

The style DRF is a 5-chaser diehead for use on machines having a revolving spindle. There are only three main parts—the body, cup and adjusting plate. Pitch diameter adjustment is easy and positive, all chasers are simultaneously actuated without disturbing the setup. The head is suitable for either right or left hand threading. Opens and closes by means of external yoke spool. Chasers are interchangeable with those of DSF dieheads of same capacity.

See pages 16 - 18 for available shank options.

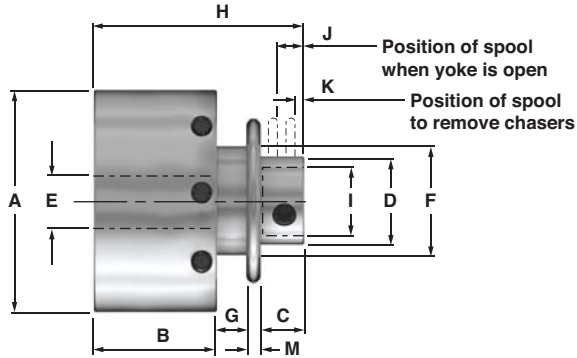

DRF Circular Chaser Head Dimensions

EDP	Size of Diehead	Straight Threads Inches	Straight Threads					
			A	B	C	D	E	
7092	13/16	.438 - .812	IN.	3.63	2.06	0.8	1.5	0.88
7085	1	.438 - 1.000	IN.	4.06	2.25	0.8	1.5	1.06
7089	1-5/8	.500 - 1.625	IN.	4.88	2.25	0.92	2.75	1.69
7093	2-3/8	1.000 - 2.375	IN.	6	2.56	0.71	3	1.44

EDP	Size of Diehead	F	G	H	I	J	K	M
7085	1	2	0.56	3.86	1.1	0.49	0.05	0.24
7089	1-5/8	3.5	0.75	4.18	1.1	0.58	0.05	0.25
7093	2-3/8	3.88	0.75	4.28	1.75	0.33	0.05	0.25

Component Parts Breakdown

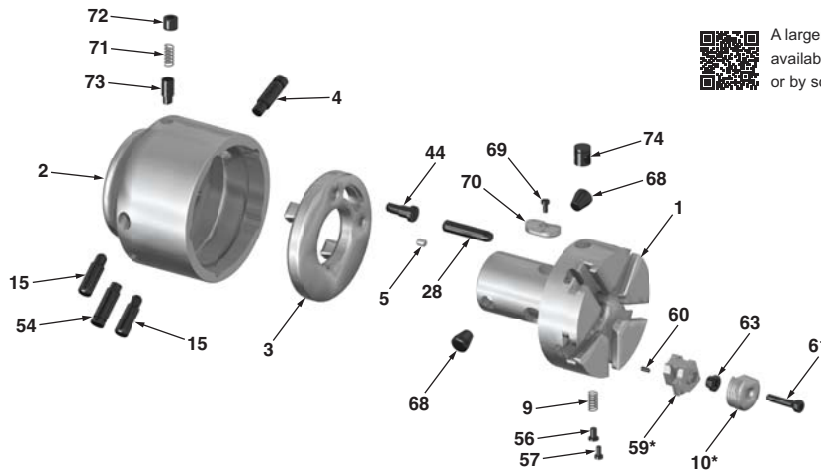

A larger version of this parts breakdown is available at - www.rsptooling.com/prints.html or by scanning this QR code.

Part#	Description	Unit Reqd	13/16	1"	1-5/8"	2-3/8"
			EDP No.	EDP No.	EDP No.	EDP No.
DRF-1A	Body assembly	1	2914	2905	2923	2934
DRF-2A	Cup assembly	1	2915	2906	2924	2935
DRF-3A	Adjusting plate assembly	1	2913	2907	2921	2933
DRF-4	Retaining screw	1	3028	3087	3028	3032
DRF-5	Stop pin in DRF-3A	1	3029	3029	3029	3029
DRF-9	Chaser spring	5	3233	3233	3244	3244
DRF-9HD	Chaser spring HD	5	3227	3227	3240	3240
DRF-15	Adjusting screw DRF-2A	2	3030	3027	3031	3033
DRF-28	Guide pin DRF-3A	1	3099	3100	3157	3157
DRF-44	Adjusting plate screw	1	3037	3037	3037	3037
DRF-54	Chaser locking screw	1	3044	3163	3044	3032
DRF-56	Spring plunger/DRF-9	5	3080	3080	3046	3046
DRF-57	Spring plunger screw	5	3045	3045	3045	3045
DRF-60	Pin in block	5	3247	3247	3252	3255
DRF-61	Chaser screw	5	**	**	**	**
DRF-63	Serrated bushing	5	**	**	**	**
DRF-68	Shank Locking Screw	2	1419	1419	1419	1419
DRF-69	Groove Insert Screw	1	1420	1420	1420	1420
DRF-70	Plunger Groove Insert	1	101	102	103	115
DRF-71	Spring/DRF-73	1	3228	3228	3246	3254
DRF-72	Retaining screw/DRF-73	1	3201	3201	3201	3201
DRF-73	Die cup retaining plunger	1	3153	3153	3153	3153
DRF-74A	Float bushing assembly	1	2908	2908	2922	2922

* See pages 21-22 for available standard block and chaser sizes.

** See Page 19

DRD For Limited Length Clearance

For use on Davenport automatics, rotary transfer and other machines with limited clearance. This diehead meets the need for a short bodied, revolving tool that has all the features incorporated in RSVP dieheads. The simplicity of the heads three main parts assures longer life and economy of operation with sustained accuracy. Chasers are available both for threading and hollow milling.

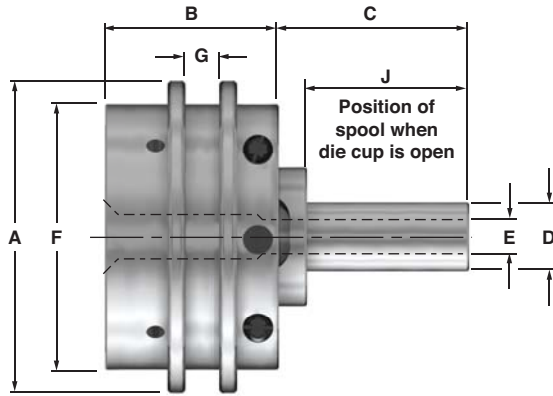

DRD Circular Chaser Head Dimensions

EDP	Size of Diehead	Straight Threads			A	B	C
		Inches	IN.				
7009	DRD 5/16	.056-.312	IN.	2.5	1.31	1.75	
7010	DRD 3/8	.188-.375	IN.	3.13	1.72	1.66	
7011	DRD 9/16	.250-.562	IN.	3.38	1.88	1.97	

EDP	Size of Diehead	D	E	F	G	J
7010	DRD 3/8	.075	0.56	2.63	0.38	1.75
7011	DRD 9/16	.075	0.63	2.88	0.38	1.75

Component Parts Breakdown

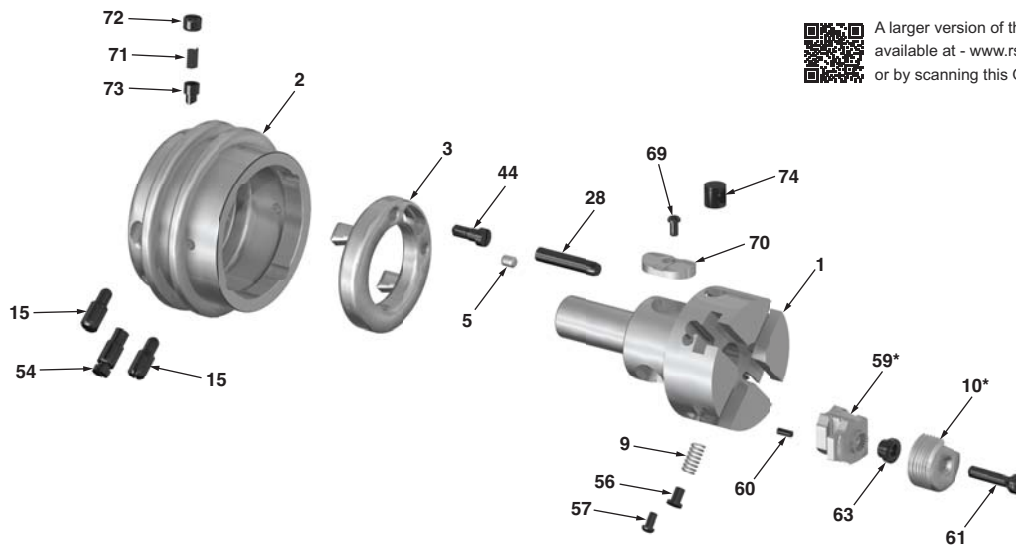

A larger version of this parts breakdown is available at - www.rsvptooling.com/prints.html or by scanning this QR code.

Part #	Description	5/16"		3/8"		9/16"	
		Unit Reqd	EDP No.	Unit Reqd	EDP No.	Unit Reqd	EDP No.
DRD-1A	Body assembly	1	2996	1	2998	1	3000
DRD-2A	Cup assembly	1	2997	1	2999	1	3001
DRD-3A	Adjusting plate assembly	1	2962	1	2959	1	2952
DRD-5	Stop pin in DRD-3A	1	3021	1	3025	1	3025
DRD-9	Chaser spring	4	3218	4	3226	4	3233
DRD-9HD	Chaser spring HD	4	3195	4	3233	4	3227
DRD-15	Adj screw in DRD-2A	2	3019	2	3026	2	3022
DRD-28	Guide pin	1	3174	1	3171	1	3164
DRD-44	Adjusting plate screw	1	3037	1	3037	1	30377
DRD-54	Chaser locking screw	1	3146	1	3043	1	3042
DRD-56	Spring plunger for DRD-9	4	3073	4	3080	4	3080
DRD-57	Spring plunger screw	4	3045	4	3045	4	3045
DRD-60	Pin in block	4	3071	4	3247	4	3247
DRD-61	Chaser screw	4	**	4	**	4	**
DRD-63	Serrated bushing	4	**	4	**	4	**
DRD-71	Spring for DRD-73	2	3143	2	3197	2	3220
DRD-72	Retaining screw for DRD-73	2	3147	2	3263	2	3152
DRD-73	Die cup retaining plunger	2	3165	2	3161	2	3261
DRD-74A	Float bushing assembly	1	2953	1	2953	1	2953

* See pages 21-22 for available standard block and chaser sizes.

** See Page 19

DS Self Opening Stationary Dieheads

The style DS diehead is specially designed for use on turret and capstan lathes. It is quickly adaptable for straight, taper, right hand and left hand threads or hollow milling.

The head is specially suitable for close to shoulder threads as the chasers move back from the shoulder immediately when the diehead opens.

The head is equipped with a lateral compensating float. Chasers and chaser blocks may be released simply by pulling up the handle and sliding back the cup unit. Chasers are interchangeable with DR, DBS and DRD heads of the same capacity.



DS Circular Chaser Head Dimensions

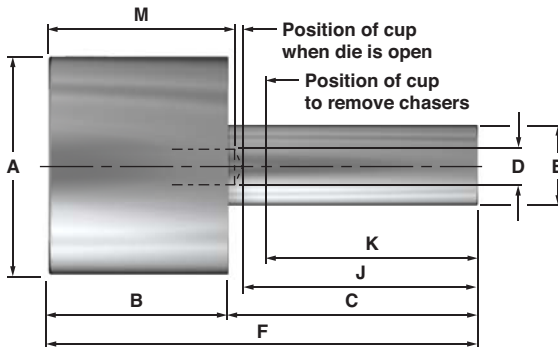

EDP	Size of Diehead	Straight Threads Inches	A	B	C	D
7012	3/8	.188-.375	IN. 2.63	2.13	3.69	0.56
7013	9/16	.250-.562	IN. 2.88	2.84	3.78	0.63
7014	13/16	.250-.812	IN. 3.63	3.19	4.63	0.88
7015	1	.375-1.000	IN. 4.06	3.34	4.63	1.06
7016	1-5/8	.500-1.625	IN. 4.88	3.84	5.78	1.69

EDP	Size of Diehead	Plus E	F	J	K	M
7012	3/8	1	5.78	3.47	3	1.99
7013	9/16	1.5	6.70	3.53	3	2.88
7014	13/16	1.5	7.80	4.28	3.75	3.13
7015	1	1.5	7.94	4.28	3.75	3.28
7016	1-5/8	2.13	9.83	5.41	4.75	3.81



A larger version of this parts breakdown is available at - www.rsvptooling.com/prints.html or by scanning this QR code.

Component Parts Breakdown

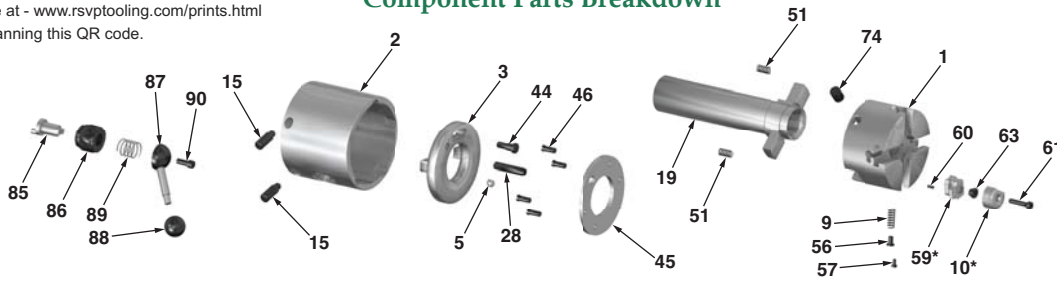

Part#	Description	3/8"		9/16"		13/16"		1"		1-5/8"	
		Unit Reqd	EDP No.	Unit Reqd	EDP No.	Unit Reqd	EDP No.	Unit Reqd	EDP No.	Unit Reqd	EDP No.
DS-1A	Body assembly	1	2983	1	2980	1	2963	1	2972	1	2925
DS-2A	Cup assembly	1	2984	1	2981	1	2964	1	2973	1	2926
DS-3A	Adjusting plate assembly	1	2985	1	2982	1	2965	1	2968	1	2927
DS-5	Stop pin	1	3025	1	3025	1	3029	1	3029	1	3029
DS-9	Chaser spring	4	3226	4	3233	4	3239	4	3244	4	3244
DS-9HD	Chaser spring HD	4	3233	4	3227	4	3250	4	3240	4	3240
DS-15	Adjusting screw in DS-2	2	3026	2	3022	2	3030	2	3027	2	3031
DS-19	Shank	1	3064	1	3053	1	3061	1	3057	1	3155
DS-28	Guide pin DS-3A	1	3173	1	3170	1	3102	1	3102	1	3172
DS-44	Adjusting plate screw	1	3036	1	3036	1	3037	1	3037	1	3037
DS-45	Spring plate	1	3065	1	3054	1	3062	1	3058	1	3067
DS-46	Spring plate screw	4	3038	4	3039	4	3039	4	3039	4	3040
DS-51	Shank pull back spring	2	3041	2	3232	2	3238	2	3238	2	3243
DS-56	Spring plunger for DS-9	4	3080	4	3080	4	3080	4	3046	4	3046
DS-57	Spring plunger screw	4	3045	4	3045	4	3045	4	3045	4	3045
DS-60	Pin in block	4	3247	4	3247	4	3247	4	3252	4	3255
DS-61	Chaser screw	4	**	4	**	4	**	4	**	4	**
DS-63	Serrated bushing	4	**	4	**	4	**	4	**	4	**
DS-74A	Float bushing assembly	1	2953	1	2953	1	2908	1	2908	1	2922
DS-85	Reset cam only	1	3169	1	3108	1	3110	1	3110	1	3112
DS-85A	Reset cam assembly	1	2901	1	2902	1	2903	1	2903	1	2904
DS-86	Cam holder	1	3107	1	3109	1	3111	1	3111	1	3113
DS-87	Reset handle	1	3168	1	3168	1	3166	1	3166	1	3149
DS-87S	Straight line closing lever	-	-	-	-	1	3017	1	3017	1	3016
DS-88	Handle ball	1	3096	1	3096	1	3096	1	3096	1	3097
DS-R9	Reset cam spring	1	3105	1	3104	1	3106	1	3106	1	3103
DS-90	Handle screw	1	3248	1	3248	1	3257	1	3257	1	3258

* See pages 21-22 for available standard block and chaser sizes.

** See Page 19

DSF For Stationary Dieheads

The style DSF is a 5-chaser diehead specially designed for use on turret and capstan lathes. It is quickly adaptable for straight, taper, right hand and left hand threads. The head is specially suitable for close to shoulder threads as the chasers move back from the shoulder immediately the dieheads opens.



The head is equipped with a lateral compensating float. Chasers and chaser blocks may be released simply by pulling up the handle and sliding back the cup unit. Chasers are interchangeable with DRF heads of the same capacity.

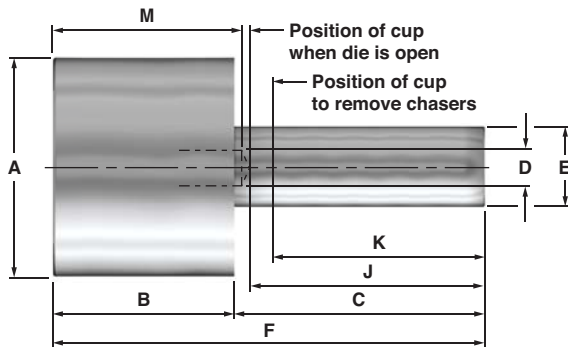

DSF Circular Chaser Head Dimensions

EDP	Size of Diehead	Straight Threads Inches	A	B	C	D	
7026	1	.438-1.000	IN	4.06	3.34	4.63	1.06
7027	1-5/8	.500-1.625	IN	4.88	3.84	5.78	1.69
7028	2-3/8	1.00-2.375	IN	6	3.84	7.03	2.44

EDP	Size of Diehead	E	F	J	Plus K	M
7026	1	1.5	8.73	4.28	3.75	4.06
7027	1-5/8	2.13	10.61	5.41	4.75	4.59
7028	2-3/8	3.25	12.06	6.57	6	4.63

▼ Also supplied with 1 1/2 in. shank is standard

Component Parts Breakdown

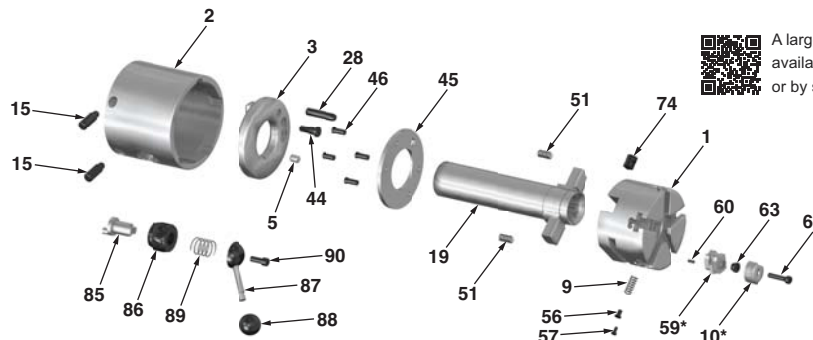

A larger version of this parts breakdown is available at - www.rsvptooling.com/prints.html or by scanning this QR code.

Part#	Unit Description	1"		1-5/8"		2-3/8"	
		EDP Req'd	Unit No.	EDP Req'd	Unit No.	EDP Req'd	No.
DSF-1A	Body assembly	1	2966	1	2942	1	2948
DSF-2A	Cup assembly	1	2967	1	2943	1	2949
DSF-3A	Adjusting plate assembly	1	2968	1	2927	1	2946
DSF-5	Stop pin	1	3029	1	3029	1	3029
DSF-9	Chaser spring	5	3233	5	3244	5	3244
DSF-9HD	Chaser spring heavy duty	5	3277	5	3240	5	3240
DSF-15	Adjusting screw in DSF-2A	2	3027	2	3031	2	3033
DSF-19	Shank	1	3057	1	3155	1	3059
DSF-19	Shank (2 3/4 Diameter)	-	-	1	3066	-	-
DSF-28	Guide pin	1	3102	1	3172	1	3172
DSF-44	Adjusting plate screw	1	3037	1	3037	1	30377
DSF-45	Spring plate	1	3058	1	3067	1	3060
DSF-46	Spring plate screw	4	3039	4	3040	4	3040
DSF-51	Shank pull back spring	2	3238	2	3243	2	3249
DSF-56	Spring plunger for DSF-9	5	3080	5	3046	5	3046
DSF-57	Spring plunger screw	5	3045	5	3045	5	3045
DSF-60	Pin in block	5	3247	5	3252	5	3255
DSF-61	Chaser screw	5	**	5	**	5	**
DSF-63	Serrated bushing	5	**	5	**	5	**
DSF-74A	Float bushing assembly	1	2908	1	2922	1	2922
DSF-85	Reset cam only	1	3110	1	3112	1	3112
DSF-85A	Reset cam assembly	1	2903	1	2904	1	2947
DSF-86	Cam holder	1	3111	1	3113	1	3113
DSF-87	Reset handle	1	3166	1	3149	1	3114
DSF-87S	Straight line spring lever	1	3017	1	3016	1	3016
DSF-88	Handle ball	1	3096	1	3097	1	3097
DSF-89	Reset cam spring	1	3106	1	3103	1	3103
DSF-90	Handle screw	1	3257	1	3258	1	3258

* See pages 21-22 for available standard block and chaser sizes.

** See Page 19

DBS For Single Spindle Automatic Screw Machines

The style DBS diehead has been specially developed for use with single-spindle automatic screw machines. The outstanding success of this head is due to its rugged simplicity and its power to maintain precision under the most severe production conditions. Two adjusting screws provide simultaneous diameter adjustment, eliminating individual chaser adjustment. Close to shoulder threading is a feature of design. Right hand and left hand threads cut with the same set of chasers, different chaser blocks only being necessary

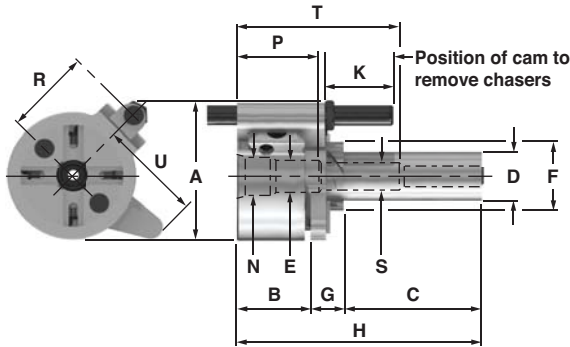

DBS Circular Chaser Head Dimensions

EDP	Size of Diehead	Straight Threads		A	B	C	D	E	F
		Inches	IN.						
7017	3/8	.188-.375	IN.	2.63	1.41	1.81	0.75	0.41	1.38
7018	9/16	.250-.562	IN.	2.88	1.41	2.06	1	0.59	1.56

EDP	Size of Diehead	G	H	P	R	S	T	U
7018	9/16	2.03	4.13	1.58	1.75	0.52	2.70	2.16

Component Parts Breakdown

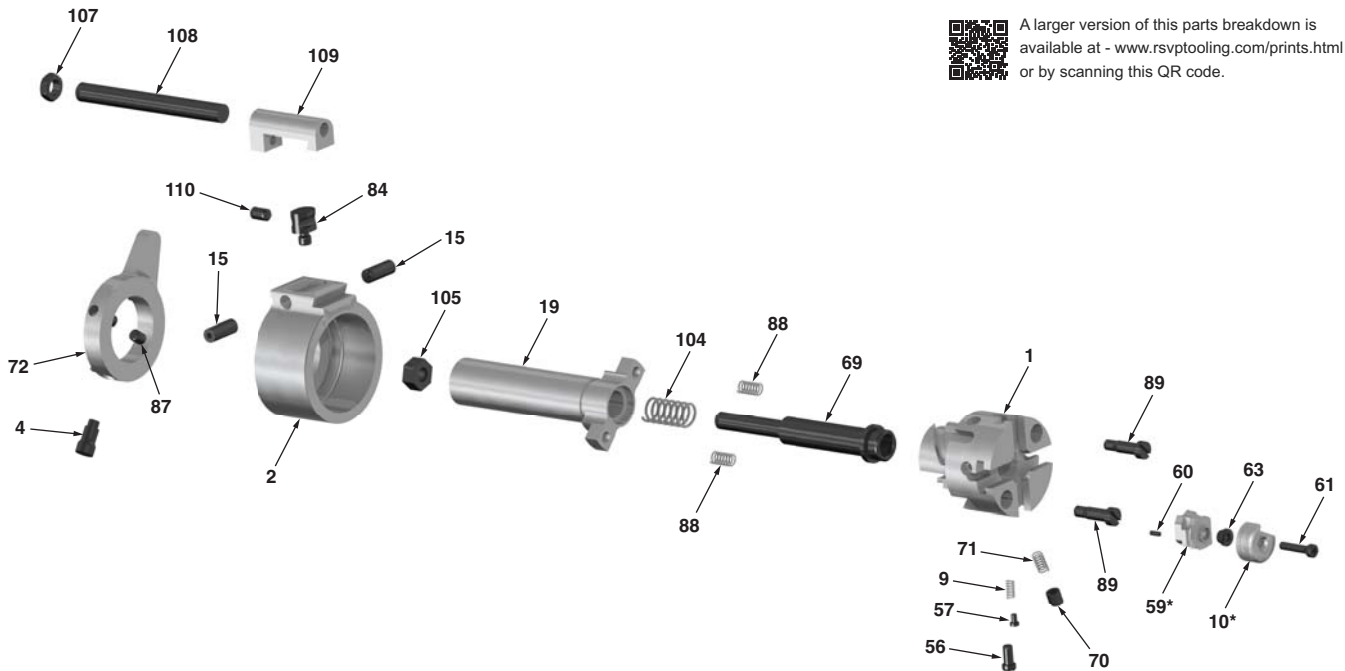

A larger version of this parts breakdown is available at - www.rsvptooling.com/prints.html or by scanning this QR code.

Part#	Unit Description	3/8"		9/16"	
		EDP Reqd	Unit No.	EDP Reqd	Unit No.
DBS-1A	Body assembly	1	2993	1	3002
DBS-2A	Cup assembly	1	2994	1	3003
DBS-4	Retaining screw	1	3130	1	3130
DBS-9	Chaser spring	4	3226	4	3233
DBS-9HD	Chaser spring HD	4	3233	4	3227
DBS-15	Adjusting screw	2	3242	2	3242
DBS-19	Shank	1	3128	1	3131
DBS-56	Spring plunger/DBS-9	4	3080	4	3080
DBS-57	Spring plunger screw	4	3045	4	3045
DBS-60	Pin in block	4	3247	4	3247
DBS-61	Chaser screw	4	**	4	**
DBS-63	Serrated bushing	4	**	4	**
DBS-69	Shank bushing	1	3129	1	3132

** See Page 19

Part#	Unit Description	3/8"		9/16"	
		EDP Reqd	Unit No.	EDP Reqd	Unit No.
DBS-70	Cup retaining plunger	1	3141	1	3141
DBS-71	Spring/retaining plunger	1	3142	1	3142
DBS-72A	Resetting ring assembly	1	2995	1	3004
DBS-84	Adjusting block	1	3148	1	3148
DBS-87	Resetting ring pin	2	3256	2	3133
DBS-88	Compensating float spring	2	3081	2	3140
DBS-89	Screw for float spring	2	3138	2	3137
DBS-104	Shank tension spring	1	3139	1	3134
DBS-105	Shank nut	1	3176	1	3177
DBS-107	Lock nut for trip rod	1	3253	1	3253
DBS-108	Trip rod	1	3119	1	3119
DBS-109	Stop bracket	1	3160	1	3160
DBS-110	Lock screw/stop bracket	1	3235	1	3225

* See pages 21-22 for available standard block and chaser sizes.

DRSA

The DRSA is a light solid adjustable diehead for use with circular chasers where reversing of the machine spindle is preferred over opening of the diehead. Popular uses include CNC machining centers and Rotary Transfer machines.

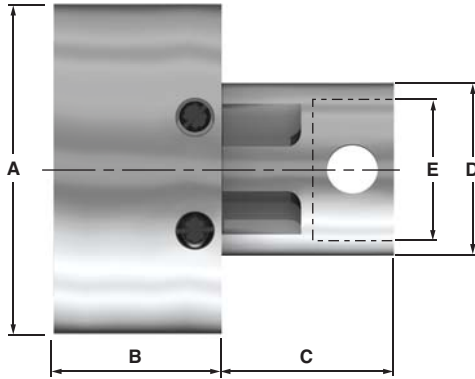

DRSA Circular Chaser Head Dimensions

EDP	Size of Head	Straight Threads Inches		A	B	C	D	E
7084 SA	9/16	.250-.562	IN.	2.88	1.47	1.92	1.5	0.93
7091 SA	13/16	.250-.562	IN.	3.63	1.63	2.03	1.5	0.93
7087 SA	1	.250-.812	IN.	4.06	1.81	2	1.63	1.1
7088 SA	1-1/16	.375-1.000	IN.	3.88	1.63	2.05	1.63	1.1
7083 SA	1-5/8	.500-1.062	IN.	4.88	1.89	2.38	2.75	1.1

Component Parts Breakdown

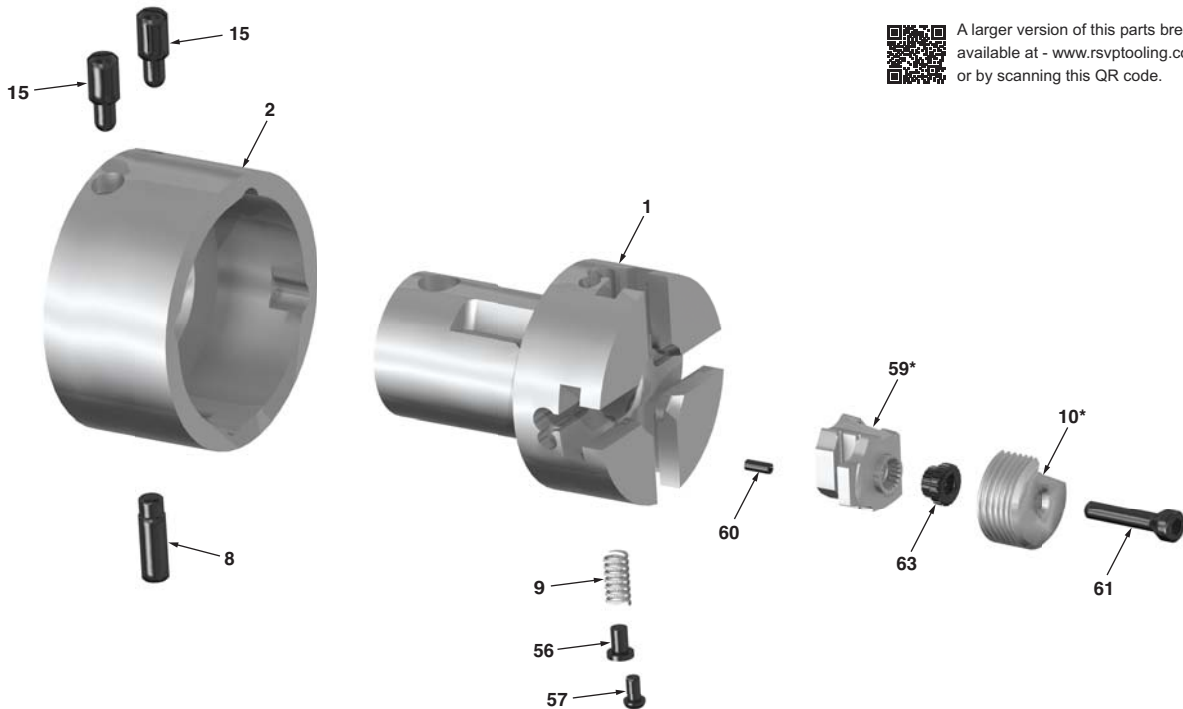

A larger version of this parts breakdown is available at - www.rsvptooling.com/prints.html or by scanning this QR code.

Part#	Unit Description	Reqd	9/16" EDP No.	13/16" EDP No.	1" EDP No.	1-1/16" EDP No.	1-5/8" EDP No.
DRSA-1A	Body Assy	1	2992M-SA	2911M-SA	2909M-SA	2916M-SA	2919M-SA
DRSA-2	Diecup	1	2951 SA	2912 SA	2910 SA	2917 SA	2920 SA
DRSA-8	Cup Rtnr Screw	1	1726	1726	1727	1727	1728
DR-9	Chaser Spring	4	3233	3239	3244	3239	3244
DR-15	Adjusting Screw	2	1014	1725	1499	3030	3031
DR-56	Spring plunger for DR-9	4	3080	3080	3046	3080	3046
DR-57	Spring plunger screw	4	3045	3045	3045	3045	3045
DR-60	Pin in block	4	3247	3247	3247	3247	3255
DR-61	Chaser screw	**	**	**	**	**	**
DR-63	Serrated brushing	**	**	**	**	**	**

* See pages 21-22 for available standard block and chaser sizes.

** See Page 19

DRSA-Biltz

RSVP Tooling offers a special version of the DRSA with an integral Biltz style shank for use in #2 QC tool holders. This option provides the versatility of combining the external threading tool with tension and compression type holders where necessary in your operation similar to those available for tapping operations.

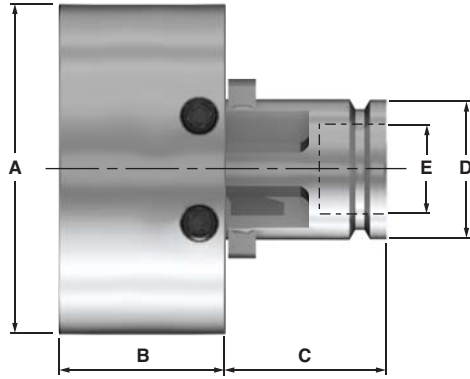

DRSA-Biltz Circular Chaser Head Dimensions

EDP	Size of Head	Straight Threads Inches		A	B	C
7084 SA-Biltz	9/16	.250-.562	IN.	2.8740	1.4560	1.4090
7085 SA-Biltz	13/16	.250-.562	IN.	3.6300	1.6300	2.0700
7086 SA-Biltz	1	.250-.812	IN.	4.0600	1.8600	2.0700
7087 SA-Biltz	1-1/16	.375-1.000	IN.	3.8750	1.6200	2.0700

EDP	Size of Head	D	E	F	G	Use QA#
7084 SA-Biltz	9/16	1.2195	0.5000	0.8125	0.6250	QA-2
7085 SA-Biltz	13/16	1.2195	0.5000	0.8125	0.6250	QA-2
7086 SA-Biltz	1	1.2195	0.6250	1.1250	1.0000	QA-2
7087 SA-Biltz	1-1/16	1.2195	0.6250	1.1250	1.0000	QA-2

Component Parts Breakdown

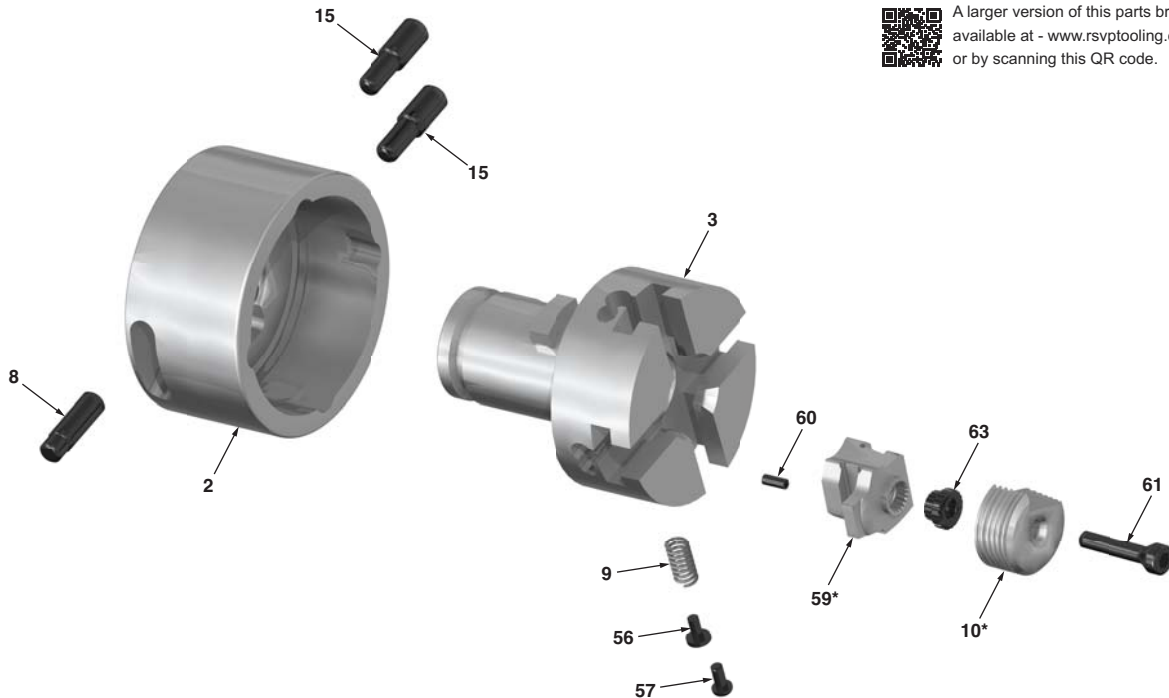

A larger version of this parts breakdown is available at - www.rsvptooling.com/prints.html or by scanning this QR code.

Part#	Description	Unit Reqd	9/16"	13/16"	1"	1-1/16"
			EDP No.	EDP No.	EDP No.	EDP No.
DRSA-1A	Body Assy	1	2992B-SA	2911B-SA	2909B-SA	2916B-SA
DRSA-2	Diecup	1	2951B SA	2912B SA	2910B SA	2917B SA
DRSA-8	Cup Rtnr Screw	1	1726	1726	1727	1727
DR-9	Chaser Spring	4	3233	3239	3244	3239
DR-15	Adjusting Screw	2	1014	1725	1499	3030
DR-56	Spring plunger for DR-9	4	3080	3080	3046	3080
DR-57	Spring plunger screw	4	3045	3045	3045	3045
DR-60	Pin in block	4	3247	3247	3247	3247
DR-61	Chaser screw	**	**	**	**	**
DR-63	Serrated brushing	**	**	**	**	**

* See pages 21-22 for available standard block and chaser sizes.

** See Page 19

DRFSA

The DRFSA is an excellent option for machining components with interrupted features in applications where reversing of the spindle is preferred to an opening type diehead. Can be used in the same manner as rigid tapping in CNC, Milling or Rotary Transfer type machines.

See pages 16 - 18 for available shank options.

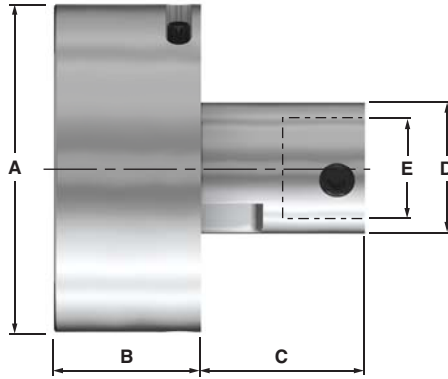

DRFSA Circular Chaser Head Dimensions

EDP	Size of Head	Straight Threads Inches	A	B	C	D	E	
7092 SA	13/16	.250-.562	IN.	3.63	1.63	2.03	1.5	0.93
7085 SA	1	.250-.812	IN.	4.06	1.86	2	1.63	1.1
7089 SA	1-5/8	.500-1.062	IN.	4.88	1.89	2.38	2.75	1.1
7093 SA	2-3/8	1.00-2.375	IN.	6	2.56	3.75	2.75	1.75

Component Parts Breakdown

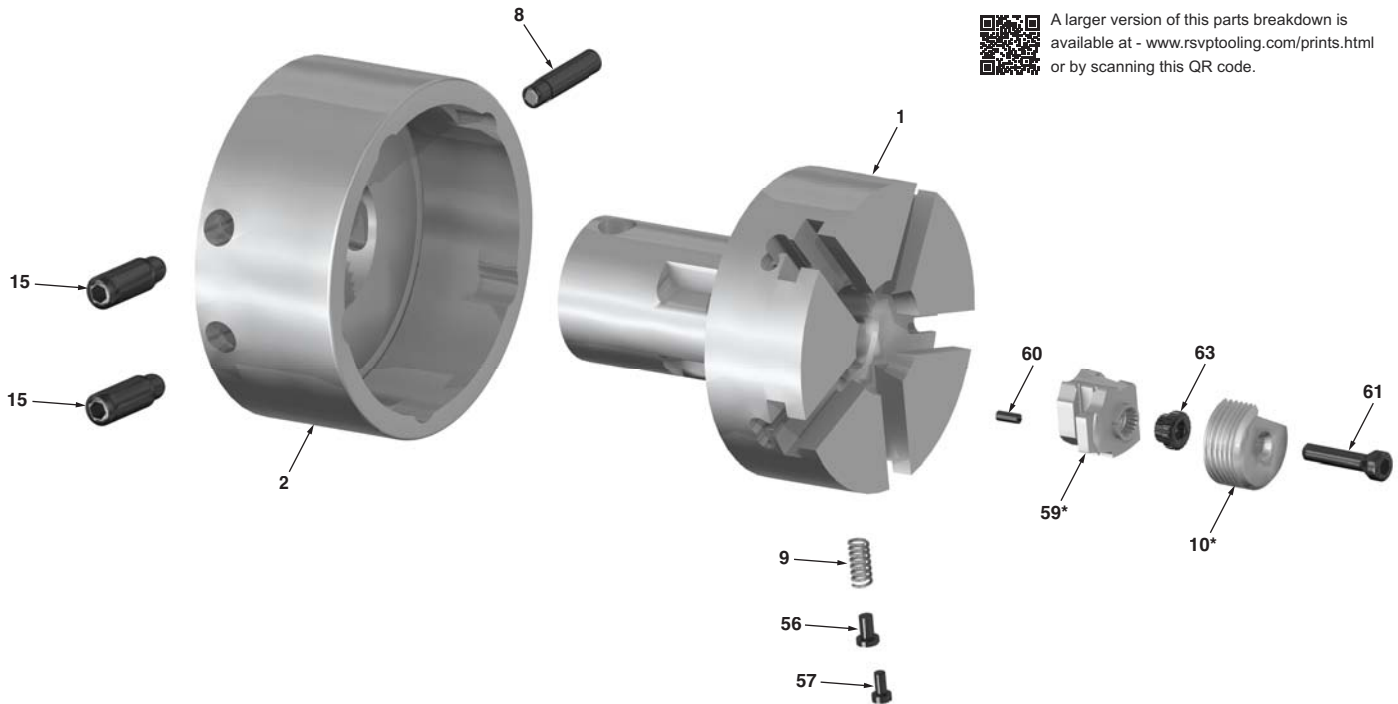

A larger version of this parts breakdown is available at - www.rsvptooling.com/prints.html or by scanning this QR code.

Part#	Description	Unit Reqd	13/16"	1"	1-5/8"	2-3/8"
			EDP No.	EDP No.	EDP No.	EDP No.
DRFSA-1A	Body Assy	1	2914M-SA	2905M-SA	2923M-SA	2934M-SA
DRFSA-2	Diecup	1	2915 SA	2916 SA	2924 SA	2935 SA
DRSFA-8	Cup Rtnr Screw	1	1726	1727	1727	1728
DR-9	Chaser Spring	5	3080	3080	3046	3046
DR-15	Adjusting Screw	2	3045	3045	3045	3045
DR-56	Spring plunger for DR-9	5	3247	3247	3252	3255
DR-57	Spring plunger screw	5	3080	3080	3046	3046
DR-60	Pin in block	5	3045	3045	3045	3045
DR-61	Chaser screw	**	**	**	**	**
DR-63	Serrated brushing	**	**	**	**	**

* See pages 21-22 for available standard block and chaser sizes.

** See Page 19

CUSTOM Circular Chaser Heads

Not only does RSVP Tooling distribute a wide range of thread cutting die heads, chasers, thread rolling attachments and thread rolls in North America but they are also supported by a dedicated manufacturing division. They have 60 plus years of threading tool production, combined with the latest CNC technology, enabling them to design and deliver solutions for virtually any circular chaser threading application.



SPECIAL SERVICES Price Upon Request

NYLOX Screws - Replace conventional screws with NYLOX screws to prevent dieheads from prematurely opening.

Black Oxide Diehead Bodies - Increase tool life, combat oxidation from setting in during machine's idle time.

Keeper Key Slots - Prevent tool pull out; let us modify your diehead shanks.

Single Replacement Circular Chasers and Blocks - There may come a time when you need just one chaser or block to complete a set. Let us know, we can complete that set and have it running again.

Special Diehead Shanks - The shanks can be manufactured to any configuration to suit your needs.

Premium Grade Materials - S-390 and ASP23 grade materials will increase your cutting and chaser tool life at a fraction of the cost.

Refurbish and Repair Dieheads - All repairs done by our factory trained personnel. If the repair estimate is too costly, or beyond repair, you may trade in your old diehead for a credit on the purchase of a new diehead.

Complete Diehead refurbishment options available including regrind of cup cam and shank / die body rework when specific conditions are present.



OVER SIZED Circular Chaser Heads

Standard threading diameters of circular chaser dieheads may be increased (subject to factory approval) as shown in the chart below. Oversize pipe threads can also be cut when diameters and length of threads are within the limits shown.

However, specifying standard equipment whenever possible avoids delay and extra expense. An additional set-up charge is made for chasers over standard rated capacity even though thread form, pitch and diameter are standard

Style of Diehead & Rated Capacity	Oversize Diameter (inches)	Coarsest Pitch	Maximum Threading Length (Oversize)						
			Standard Head (inches)	Reboring Die Body (inches)					
DR-DRD-5/16	11/32	18	Full length						
	15/32	20	9/16						
	1/2	13	3-7/16						
DBS-9/16	9/16	18	2-5/16						
	3/4	16	1-5/16						
	7/8	18	3/4						
	1	18	9/16						
DR-DRD-DS-9/16	5/8	11	15/16	Full length					
	3/4	16	3/4	1-1/8					
	7/8	18	3/4						
	1	18	9/16						
DR-DS-13/16	7/8	9	1	Full length					
					DRF-DSF	1	14	3/4	1-1/4
DR-DS-1	1-3/16	12	3/4	4-3/8					
					DRF-DSF	1-1/4	12	3/4	1-1/4
DR-DS-1	1-1/4	12	3/4	1-1/4					
					DRF-DSF	1-1/4	12	3/4	1-1/4
					DRF-DSF	1-5/16	12	3/4	
					DRF-DSF	1-3/8	12	3/4	
					DRF-DSF	1-1/2	16	3/4	
DR-DS-1	1-5/8	16	3/4						
					DRF-DSF	1-5/8	16	3/4	

Style of Diehead & Rated Capacity	Oversize Diameter (inches)	Coarsest Pitch	Maximum Threading Length (Oversize)						
			Standard Head (inches)	Reboring Die Body (inches)					
DR-1-1/16	1-1/8	12	3/4	1-1/2					
					DRF-DSF	1-3/16	12	3/4	1-1/2
					DRF-DSF	1-1/4	12	3/4	
					DRF-DSF	1-3/8	12	3/4	
					DRF-DSF	1-1/2	16	3/4	
DR-DS-1-5/8	1-3/4	12	7/8						
					DRF-DSF	1-7/8	12	7/8	
DR-2	2	12	7/8	4-3/8					
					DRF-DSF	1-3/4	12	7/8	4-3/8
DR-DS-2-3/8	2-1/2	8	1-1/8	5-1/2					
					DRF-DSF	1-7/8	12	7/8	1-1/2
					DRF-DSF	2	12	7/8	1-1/2
					DRF-DSF	2-1/8	12	7/8	
					DRF-DSF	2-1/4	12	7/8	
DR-DS-2-3/8	2-3/8	16	7/8						
					DRF-DSF	2-1/2	8	1-1/8	5-1/2
					DRF-DSF	2-5/8	10	1-1/8	
DR-DS-2-3/8	2-3/4	10	1-1/8						
					DRF-DSF	2-7/8	10	1-1/8	
DR-DS-2-3/8	3	10	1-1/8						
					DRF-DSF	3	10	1-1/8	

Note: Larger oversize thread diameter than those indicated will be considered upon application.

SHANKS Stock Modular Shanks Available To Use With Circular Chaser Heads

STRAIGHT



EDP	For Model	A	D	L
0110	9/16 DR, DRD & DRSA	0.9251	1	1.82
0111	13/16 DR, DRF, DRSA & DRFSA	0.9251	1.5	2.921
0120	1 DR, DRD, DRSA & DRFSA	1.1023	1	1.82
0117	1-1/16 DR	1.1023	1.5	2.921
0125	2 DR	1.75	2	1.82
0127	2-3/8 DRF	1.75	2.75	2.921

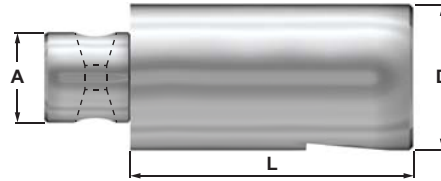

STRAIGHT COOLANT



EDP	For Model	A	B	C	D	L
0110-CI	9/16 DR, DRD & DRSA	0.9251	1.713	0.0787	1	1.82
0111-CI	13/16 DR, DRF, DRSA & DRFSA	0.9251	1.713	0.0787	1.5	2.92
0120-CI	1 DR, DRF, DRSA & DRFSA	1.1023	1.713	0.0787	1	1.82
0117-CI	1-5/8 DR & DRF	1.1023	1.713	0.0787	1.5	2.921
0125-CI	2 DR	1.75	1.87	0.0787	2	1.82
0127-CI	2-3/8 DRF	1.75	1.87	0.0787	2.75	2.921

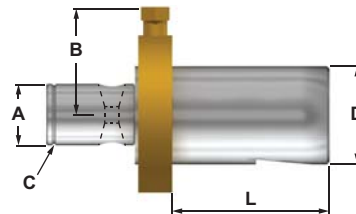

MODULAR AUTO



EDP	For Model	A	D	L
0121	9/16 DR, DRD & DRSA	Ø 0.9251	1-1/16-12ACME	6.114
0104	13/16 DR, DRF, DRSA & DRFSA	Ø 0.9251	1-3/8-12ACME	7.114
0116	1 DR, DRF, DRSA & DRFSA	Ø 1.1023	1-1/16-12ACME	6.114
0104-A	1-1/16 DR	Ø 1.1023	1-3/8-12ACME	7.114

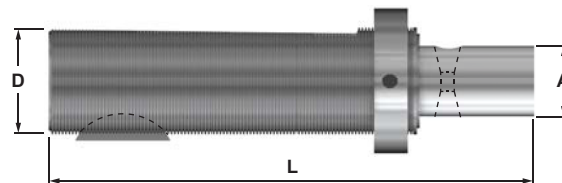

MODULAR AUTO COOLANT



EDP	For Model	A	B	C	D	L
0121-CI	9/16 DR, DRD & DRSA	Ø 0.9251	1.713	Ø 0.0787	1-1/16-12ACME	6.114
0104-CI	13/16 DR, DRF, DRSA & DRFSA	Ø 0.9251	1.713	Ø 0.0787	1-3/8-12ACME	7.114
0116-CI	1 DR, DRF, DRSA & DRFSA	Ø 1.1023	1.713	Ø 0.0787	1-1/16-12ACME	6.114
0104-A-CI	1-5/8 DR & DRF	Ø 1.1023	1.713	Ø 0.0787	1-3/8-12ACME	7.114

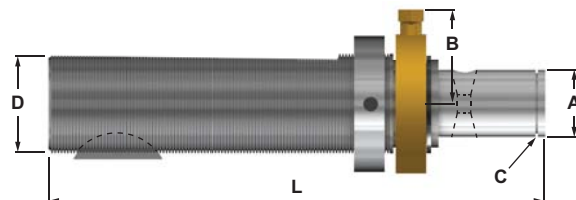

CAT-40



EDP	For Model	A
0108	9/16 DR, DRD & DRSA	0.9251
	13/16 DR, DRF, DRSA & DRFSA	
0126	1 DR, DRF, DRSA & DRFSA	1.1023
	1-1/16 DR 1-5/8 DR & DRF	
0140	2 DR	1.75
	2-3/8 DRF	



BT-40



EDP	For Model	A
0109	9/16 DR, DRD & DRSA	0.9251
	13/16 DR, DRF, DRSA & DRFSA	
0109-A	1 DR, DRF, DRSA & DRFSA	1.1023
	1-1/16 DR 1-5/8 DR & DRF	
0109-B	2 DR	1.75
	2-3/8 DRF	

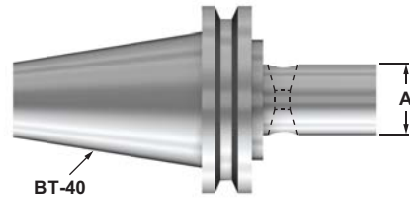

NMTB-40



EDP	For Model	A
0143	9/16 DR, DRD & DRSA	Ø 0.9251
	13/16 DR, DRF, DRSA & DRFSA	
0131	1 DR, DRF, DRSA & DRFSA	Ø 1.1023
	1-1/16 DR 1-5/8 DR & DRF	

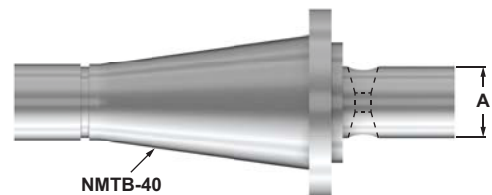

HSK 63-A



EDP	For Model	A
0107	9/16 DR, DRD & DRSA	0.9251
	13/16 DR, DRF, DRSA & DRFSA	
0138	1 DR, DRF, DRSA & DRFSA	1.1023
	1-1/16 DR 1-5/8 DR & DRF	

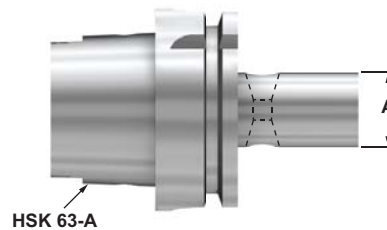

SHANKS Continued

HSK 50-A



EDP	For Model	A
0141	9/16 DR, DRD & DRSA	Ø 0.9251
	13/16 DR, DRF, DRSA & DRFSA	
	1 DR, DRF, DRSA & DRFSA	
0142	1-1/16 DR	Ø 1.1023
	1-5/8 DR & DRF	

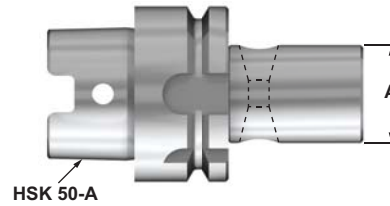

HSK 50-A COOLANT



EDP	For Model	A	B
0129	9/16 DR, DRD & DRSA	Ø 0.9251	1.713
	13/16 DR, DRF, DRSA & DRFSA		
	1 DR, DRF, DRSA & DRFSA		
0130	1-1/16 DR	Ø 1.1023	1.713
	1-5/8 DR & DRF		

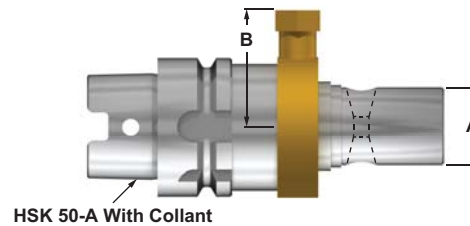

VDI-20



EDP	For Model	A
0105	9/16 DR, DRD & DRSA	0.9251
	13/16 DR, DRF, DRSA & DRFSA	
	1 DR, DRF, DRSA & DRFSA	
0105-A	1-1/16 DR	1.1023
	1-5/8 DR & DRF	

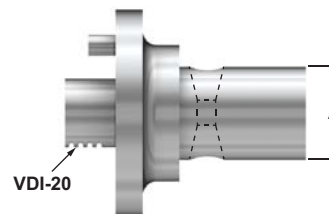

VDI-25



EDP	For Model	A
0106	9/16 DR, DRD & DRSA	0.9251
	13/16 DR, DRF, DRSA & DRFSA	
	1 DR, DRF, DRSA & DRFSA	
0106-A	1-1/16 DR	1.1023
	1-5/8 DR & DRF	

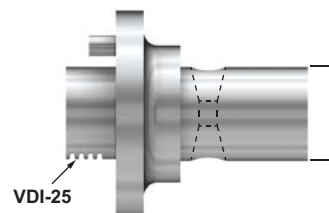

DR61 Chaser Screw Component Parts

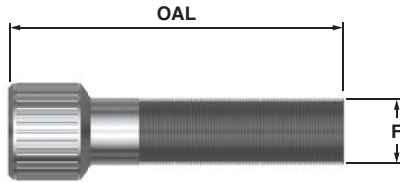

Diehead 4 Per Set	Chaser Length	Screw Diameter	OAL	EDP#	
				Left Hand	Right Hand
1/4 & 5/16	1/4 & 3/8	6-32	5/8	3196	3219
	1/4	8-32	1/2	3186	3211
3/8 & 9/16	9/16	12-28	15/16	3185	3210
	3/4	12-28	1 7/32	3189	3214
13/16 & 1" & 1 1/16	9/16	1/4-28	1 5/32	3184	3209
	3/4	1/4-28	1 3/8	3187	3212
1 5/8 & 2"	7/8 & 1"	1/4-28	1 9/16	3181	3206
	5/8	3/8-24	1 3/16	3178	3202
	7/8	3/8-24	1 7/16	3179	3203
1 5/8 & 2" Heavy Duty	1 1/8	3/8-24	1 11/16	3188	3213
	5/8	5/16-24	1 7/16	3190	3215
	7/8	5/16-24	1 11/16	3191	3216
2 3/8	1 1/8	5/16-24	1 15/16	3192	3204
	3/4	3/8-24	1 7/16	3179	3203
	1"	3/8-24	1 11/16	3188	3213
	1 1/8 & 1 1/4	3/8-24	1 15/16	3180	3205

Diehead 5 Per Set	Chaser length	Screw Diameter	OAL	EDP#	
				Left Hand	Right Hand
13/16 & 1"	9-16	12-28	15/16	3185	3210
	3/4	12-28	1 7/32	3189	3214
1 5/8	9/16	1/4-28	1 5/32	3184	3209
	3/4	1/4-28	1 3/8	3187	3212
	7/8 & 1"	1/4-28	1 9/16	3181	3206
	1 1/8	1/4-28	1 25/32	3183	3208
2 3/8	5/8	3/8-24	1 3/16	3178	3202
	7/8	3/8-24	1 7/16	3179	3203
	1 1/8	3/8-24	1 11/16	3188	3213

DR63 Chaser Serrated Bushing Chart

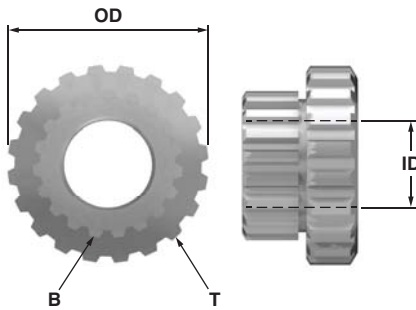

4 Chaser Style

EDP No.	Diehead	Number of Teeth		OD	ID	H
		(Bottom) (Top)				
		B	T			
3145	1/4"-5/16"	30	29	1/4"	9/64"	5/32"
3055	3/8"-9/16"	20	19	1/2"	7/32"	9/32"
3069	13/16" - 1"-11/16"	22	23	5/8"	1/4"	9/32"
3056	1 5/8"-2"	27	26	7/8"	3/8"	9/32"
3098	1 5/8"-2" HD	25	26	3/4"	5/16"	9/32"
3072	2 3/8"	27	26	15/16"	3/8"	7/16"

5 Chaser Style

EDP No.	Diehead	Number of Teeth		OD	ID	H
		(Bottom) (Top)				
		B	T			
3055	13/16 - 1"-11/16"	20	19	1/2"	7/32"	9/32"
3069	1 5/8"	23	22	5/8"	1/4"	9/32"
3056	2 3/8"	27	26	7/8"	3/8"	9/32"

*Made from HSS- Not powdered metal

CIRCULAR CHASER Accessories

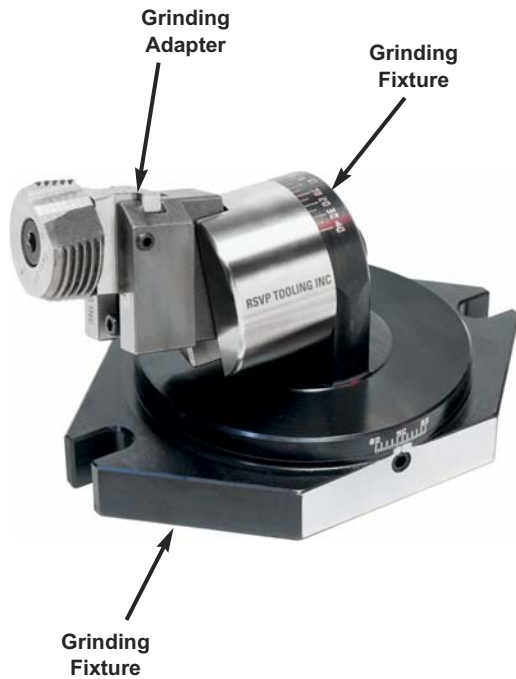

Grinding Equipment Accessories

The grinding fixture holds the grinding adapter complete with chaser and block assembly for grinding. The Base is provided with bolt slots and removable tenons for fixture direct to the grinding machine table or to a magnetic chuck. The body swivels to give the required face angle and the adapter holder rotates to give the required hook angle. One size of grinding fixture is common to all.

EDP Number
FI

Grinding Adapter

The adapter is used in conjunction with the grinding fixture and holds the chaser at a 12 degree angle for grinding the chip clearance angle.

EDP Number

- A1 1/4" and 5/16" in dieheads
- A2 3/8" dieheads
- A3 9/16" (4 chaser diehead) and 1" (5 chaser diehead)
- A4 13/16", 1", 1-1/16" (4 chaser diehead) and 1-5/8" (5 chaser diehead)
- A5 1-5/8" and 2" (4 chaser diehead) and 2-3/8" DRF (5 chaser diehead)



Micrometer Setting Gauge

This gauge is designed so that the chaser block (with the chaser mounted on it) can be checked both before and after grinding. The same gauge is used for checking both right hand and left hand chasers as well as hollow milling cutters within the size range of the gauge.

EDP Number

- M1 1/4" and 5/16" dieheads
- M2 3/8" dieheads
- M3 9/16" (4 chaser diehead) and 1" (5 chaser diehead)
- M4 13/16", 1", 1-1/16" (4 chaser diehead) and 1-5/8" (5 chaser diehead)
- M5 1-5/8" and 2" (4 chaser diehead) and 2-3/8" DRF (5 chaser diehead)



Pull Back Wrenches (Brass)

EDP Number

- PI 1/4" and 5/16" dieheads
- P2 3/8" dieheads
- P3 9/16" (4 chaser diehead) and 1" (5 chaser head)
- P4 13/16", 1", 1-1/16" (4 chaser diehead) and 1-5/8" in (5 chaser diehead)
- P5 1-5/8" and 2" (4 chaser diehead) and 2-3/8" (5 chaser diehead)



CIRCULAR CHASERS & BLOCKS (Standard 4 Per Set)

5/16" 4 Per Set Dieheads UN			
Circular Chasers		P.P.I./Form	Blocks EDP#
25 Chamfer EDP#	45 Chamfer EDP#		
4001	5001	2-56/UNC	6001
4002	5002	2-64/UNF	6002
4003	5003	3-48/UNC	6003
4004	5004	3-56/UNF	6004
4005	5005	4-40/UNC	6005
4006	5006	4.48/UNF	6006
4007	5007	5.40/UNC	6007
4008	5008	5.44/UNF	6008
4009	5009	6-32/UNC	6009
4010	5010	6-40/UNF	6010
4011	5011	8-32/UNC	6011
4012	5012	8-36/UNF	6012
4013	5013	10-24/UNC	6013
4014	5014	10-32/UNF	6014
4015	5015	12-24/UNC	6015
4016	5016	12-28/UNF	6016
4017	5017	1/4.20/UNC	6017
4018	5018	1/4.28/UNF	6018
4019	5019	5/16-18/UNC	6019
4020	5020	5/16-24/UNF	6020

Pipe			
Circular Chasers		Dia./Form	Blocks EDP#
25 Chamfer EDP#	45 Chamfer EDP#		
4021	5021	1/8 NPT/ANPT	6021
4022	5022	1/8 NPTF	6022

9/16" 4 Per Set Dieheads UN			
Circular Chasers		P.P.I./Form	Blocks EDP#
25 Chamfer EDP#	45 Chamfer EDP#		
4037	5037	1/4-20/UNC	6037
4038	5038	1/4-28/UNF	6038
4039	5039	5/16-18/UNC	6039
4040	5040	5/16-24/UNF	6040
4041	5041	3/8-16/UNC	6041
4042	5042	3/8-24/UNF	6042
4043	5043	7/16-14/UNC	6043
4044	5044	7/16-20/UNF	6044
4045	5045	1/2-13/UNC	6045
4046	5046	1/2-20/UNF	6046
4047	5047	9/16-12/UNC	6047
4048	5048	9/16-18/UNF	6048

Pipe			
Circular Chasers		Dia./Form	Blocks EDP#
25 Chamfer EDP#	45 Chamfer EDP#		
4049	5049	1/8-NPT/ANPT	6049
4050	5050	1/8-NPTF	6050
4051	5051	1/4-NPT/ANPT	6051
4052	5052	1/4-NPTF	6052
4053	5053	3/8-NPTF/ANPT	6053
4054	5054	3/8-NPTF	6054
4055	5055	1/2-NPT/ANPT	6055
4056	5056	1/2-NPTF	6056

3/8" 4 Per Set Dieheads UN			
Circular Chasers		P.P.I./Form	Blocks EDP#
25 Chamfer EDP#	45 Chamfer EDP#		
4023	5023	8-32/UNC	6023
4024	5024	8-36/UNF	6024
4025	5025	10-24/UNC	6025
4026	5026	10-32/UNF	6026
4027	5027	12-24/UNC	6027
4028	5028	12-28/UNF	6028
4029	5029	1/4-20/UNC	6029
4030	5030	1/4-28/UNF	6030
4031	5031	5/16-18/UNC	6031
4032	5032	5/16-24/UNF	6032
4033	5033	3/8-16/UNC	6033
4034	5034	3/8-24/UNF	6034

Pipe			
Circular Chasers		Dia./Form	Blocks EDP#
25 Chamfer EDP#	45 Chamfer EDP#		
4035	5035	1/8 NPT/ANPT	6035
4036	5036	1/8 NPTF	6036

13/16" 4 Per Set Dieheads UN			
Circular Chasers		P.P.I./Form	Blocks EDP#
25 Chamfer EDP#	45 Chamfer EDP#		
4057	5057	1/4-20/UNC	6057
4058	5058	1/4-28/UNF	6058
4059	5059	5/16-18/UNC	6059
4060	5060	5/16-24/UNF	6060
4061	5061	3/8-16/UNC	6061
4062	5062	3/8-24/UNF	6062
4063	5063	7/16-14/UNC	6063
4064	5064	7/16-20/UNF	6064
4065	5065	1/2-13/UNC	6065
4066	5066	1/2-20/UNF	6066
4067	5067	9/16-12/UNC	6067
4068	5068	9/16-18/UNF	6068
4069	5069	5/8-11/UNC	6069
4070	5070	5/8-18/UNF	6070
4071	5071	3/4-10/UNC	6071
4072	5072	3/4-16/UNF	6072

Pipe			
Circular Chasers		Dia./Form	Blocks EDP#
25 Chamfer EDP#	45 Chamfer EDP#		
4073	5073	1/8 NPT/ANPT	6073
4074	5074	1/8 NPTF	6074
4075	5075	1/4 NPT/ANPT	6075
4076	5076	1/4 NPTF	6076
4077	5077	3/8 NPT/ANPT	6077
4078	5078	3/8 NPTF	6078
4079	5079	1/2 NPT/ANPT	6079
4080	5080	1/2 NPTF	6080

1" 4 Per Set Dieheads UN			
Circular Chasers		P.P.I./Form	Blocks EDP#
25 Chamfer EDP#	45 Chamfer EDP#		
4081	5081	7/16-14/UNC	6081
4082	5082	7/16-20/UNF	6082
4083	5083	1/2-13/UNC	6083
4084	5084	1/2-20/UNF	6084
4085	5085	9/16-12/UNC	6085
4086	5086	9/16-18/UNF	6086
4087	5087	5/8-11/UNC	6087
4088	5088	5/8-18/UNF	6088
4089	5089	3/4-10/UNC	6089
4090	5090	3/4-16/UNF	6090
4091	5091	7/8-9/UNC	6091
4092	5092	7/8-14/UNF	6092
4093	5093	1-8/UNC	6093
4094	5094	1-12/UNF	6094

Pipe			
Circular Chasers		P.P.I./Form	Blocks EDP#
25 Chamfer EDP#	45 Chamfer EDP#		
4095	5095	1/8 NPT/ANPT	6095
4096	5096	1/8 NPTF	6096
4097	5097	1/4 NPT/ANPT	6097
4098	5098	1/4 NPTF	6098
4099	5099	3/8 NPT/ANPT	6099
4100	5100	3/8 NPTF	6100
4101	5101	1/2 NPT/ANPT	6101
4102	5102	1/2 NPTF	6102
4103	5103	3/4 NPT/ANPT	6103
4104	5104	3/4 NPTF	6104

1-5/8" 4 Per Set Dieheads UN			
Circular Chasers		P.P.I./Form	Blocks EDP#
25 Chamfer EDP#	45 Chamfer EDP#		
4149	5149	1/2-13/UNC	6149
4150	5150	1/2-20/UNF	6150
4151	5151	9/16-12/UNC	6151
4152	5152	9/16-18/UNF	6152
4153	5153	5/8-11/UNC	6153
4154	5154	5/8-18/UNF	6154
4155	5155	3/4-10/UNC	6155
4156	5156	3/4-16/UNF	6156
4157	5157	7/8-9/UNC	6157
4158	5158	7/8-14/UNF	6158
4159	5159	1-8/UNC	6159
4160	5160	1-12/UNF	6160
4161	5161	1 1/8-7/UNC	6161
4162	5162	1 1/8-12/UNF	6162
4163	5163	1 1/4-7/UNC	6163
4164	5164	1 1/4-12/UNF	6164
4165	5165	1 3/8-12/UNF	6165
4166	5166	1 1/2-12/UNF	6166

Pipe			
Circular Chasers		P.P.I./Form	Blocks EDP#
25 Chamfer EDP#	45 Chamfer EDP#		
4167	5167	1/4 NPT/ANPT	6167
4168	5168	1/4 NPTF	6168
4169	5169	3/8 NPT/ANPT	6169
4170	5170	3/8 NPTF	6170
4171	5171	1/2 NPT/ANPT	6171
4172	5172	1/2 NPTF	6172
4173	5173	3/4 NPT/ANPT	6173
4174	5174	3/4 NPTF	6174
4175	5175	1 NPT/ANPT	6175
4176	5176	1 NPTF	6176
4177	5177	1 1/4NPT/ANPT	6177
4178	5178	1 1/4NPTF	6178

1 1/16" 4 Per Set Dieheads UN			
Circular Chasers		P.P.I./Form	Blocks EDP#
25 Chamfer EDP#	45 Chamfer EDP#		
4127	5127	1/2-13/UNC	6127
4128	5128	1/2-20/UNF	6128
4129	5129	9/16-12/UNC	6129
4130	5130	9/16-18/UNF	6130
4131	5131	5/8-11/UNC	6131
4132	5132	5/8-18/UNF	6132
4133	5133	3/4-10/UNC	6133
4134	5134	3/4-16/UNF	6134
4135	5135	7/8-9/UNC	6135
4136	5136	7/8-14/UNF	6136
4137	5137	1-8/UNC	6137
4138	5138	1-12/UNF	6138

Pipe			
Circular Chasers		P.P.I./Form	Blocks EDP#
25 Chamfer EDP#	45 Chamfer EDP#		
4139	5139	1/8 NPT/ANPT	6139
4140	5140	1/8 NPTF	6140
4141	5141	1/4 NPT/ANPT	6141
4142	5142	1/4 NPTF	6142
4143	5143	3/8 NPT/ANPT	6143
4144	5144	3/8 NPTF	6144
4145	5145	1/2 NPT/ANPT	6145
4146	5146	1/2 NPTF	6146
4147	5147	3/4 NPT/ANPT	6147
4148	5148	3/4 NPTF	6148

2" 4 Per Set Dieheads UN			
Circular Chasers		P.P.I./Form	Blocks EDP#
25 Chamfer EDP#	45 Chamfer EDP#		
4209	5209	3/4-10/UNC	6209
4210	5210	3/4-16/UNF	6210
4211	5211	7/8-9/UNC	6211
4212	5212	7/8-14/UNF	6212
4213	5213	1-8/UNC	6213
4214	5214	1-12/UNF	6214
4215	5215	1 1/8-7/UNC	6215
4216	5216	1 1/8-12/UNF	6216
4217	5217	1 1/4-7/UNC	6217
4218	5218	1 1/4-12/UNF	6218
4219	5219	1 3/8-12/UNF	6219
4220	5220	1 1/2-12/UNF	6220

Pipe			
Circular Chasers		P.P.I./Form	Blocks EDP#
25 Chamfer EDP#	45 Chamfer EDP#		
4221	5221	1/2 NPT/ANPT	6221
4222	5222	1/2 NPTF	6222
4223	5223	3/4 NPT/ANPT	6223
4224	5224	3/4 NPTF	6224
4225	5225	1 NPT/ANPT	6225
4226	5226	1" NPTF	6226
4227	5227	1 1/4 NPT/ANPT	6227
4228	5228	1 1/4 NPTF	6228
4229	5229	1 1/2 NPT/ANPT	6229
4230	5230	1 1/2 NPTF	6230

CIRCULAR CHASERS & BLOCKS (Standard 5 Per Set)

13/16" 5 Per Set Dieheads UN			
Circular Chasers		P.P.I./Form	Blocks EDP#
25 Chamfer EDP#	45 Chamfer EDP#		
4247	5247	7/16-14/UNC	6247
4248	5248	7/16-20/UNF	6248
4249	5249	1/2-13/UNC	6249
4250	5250	1/2-20/UNF	6250
4251	5251	9/16-12/UNC	6251
4252	5252	9/16-18/UNF	6252
4253	5253	5/8-11/UNC	6253
4254	5254	5/8-18/UNF	6254
4255	5255	3/4-10/UNC	6255
4256	5256	3/4-16/UNF	6256

Pipe			
Circular Chasers		Dia./Form	Blocks EDP#
25 Chamfer EDP#	45 Chamfer EDP#		
4257	5257	1/8 NPT/ANPT	6257
4258	5258	1/8 NPTF	6258
4259	5259	1/4 NPT/ANPT	6259
4260	5260	1/4 NPTF	6260
4261	5261	3/8 NPT/ANPT	6261
4262	5262	3/8 NPTF	6262

1-5/8" 5 Per Set Dieheads UN			
Circular Chasers		P.P.I./Form	Blocks EDP#
25 Chamfer EDP#	45 Chamfer EDP#		
4179	5179	1/2-13/UNC	6179
4180	5180	1/2-20/UNF	6180
4181	5181	9/16-12/UNC	6181
4182	5182	9/16-18/UNF	6182
4183	5183	5/8-11/UNC	6183
4184	5184	5/8-18/UNF	6184
4185	5185	3/4-10/UNC	6185
4186	5186	3/4-16/UNF	6186
4187	5187	7/8-9/UNC	6187
4188	5188	7/8-14/UNF	6188
4189	5189	1-8/UNC	6189
4190	5190	1-12/UNF	6190
4191	5191	1-7/UNC	6191
4192	5192	1 1/8-12/UNF	6192
4193	5193	1 1/4-7/UNC	6193
4194	5194	1 1/4-12/UNF	6194
4195	5195	1 3/8-12/UNF	6195
4196	5196	1 1/2-12/UNF	6196

Pipe			
Circular Chasers		Dia./Form	Blocks EDP#
25 Chamfer EDP#	45 Chamfer EDP#		
4197	5197	1/4 NPT/ANPT	6197
4198	5198	1/4 NPTF	6198
4199	5199	3/8 NPT/ANPT	6199
4200	5200	3/8 NPTF	6200
4201	5201	1/2 NPT/ANPT	6201
4202	5202	1/2 NPTF	6202
4203	5203	3/4 NPT/ANPT	6203
4204	5204	3/4 NPTF	6204
4205	5205	1 NPT/ANPT	6205
4206	5206	1 NPTF	6206
4207	5207	1 1/4 NPT/ANPT	6207
4208	5208	1 1/4 NPTF	6208

1" 5 Per Set Dieheads UN			
Circular Chasers		P.P.I./Form	Blocks EDP#
25 Chamfer EDP#	45 Chamfer EDP#		
4105	5105	7/16-14/UNC	6105
4106	5106	7/16-20/UNF	6106
4107	5107	1/2-13/UNC	6107
4108	5108	1/2-20/UNF	6108
4109	5109	9/16-12/UNC	6109
4110	5110	9/16-18/UNF	6110
4111	5111	5/8-11/UNC	6111
4112	5112	5/8-18/UNF	6112
4113	5113	3/4-10/UNC	6113
4114	5114	3/4-16/UNF	6114
4115	5115	7/8-9/UNC	6115
4116	5116	7/8-14/UNF	6116
4117	5117	1-8/UNC	6117
4118	5118	1-12/UNF	6118

Pipe			
Circular Chasers		Dia./Form	Blocks EDP#
25 Chamfer EDP#	45 Chamfer EDP#		
4119	5119	1/4 NPT/ANPT	6119
4120	5120	1/4 NPTF	6120
4121	5121	3/8 NPT/ANPT	6121
4122	5122	3/8 NPTF	6122
4123	5123	1/2 NPT/ANPT	6123
4124	5124	1/2 NPTF	6124
4125	5125	3/4 NPT/ANPT	6125
4126	5126	3/4 NPTF	6126

2-3/8" 5 Per Set Dieheads UN			
Circular Chasers		P.P.I./Form	Blocks EDP#
25 Chamfer EDP#	45 Chamfer EDP#		
4231	5231	1-8/UNC	6231
4232	5232	1-12/UNF	6232
4233	5233	1 1/8-7/UNC	6233
4234	5234	1 1/8-12/UNF	6234
4235	5235	1 1/4-7/UNC	6235
4236	5236	1 1/4-12/UNF	6236
4237	5237	1 3/8-12/UNF	6237
4238	5238	1 1/2-12/UNF	6238

Pipe			
Circular Chasers		Dia./Form	Blocks EDP#
25 Chamfer EDP#	45 Chamfer EDP#		
4239	5239	1 NPT/ANPT	6239
4240	5240	1 NPTF	6240
4241	5241	1 1/4 NPT/ANPT	6241
4242	5242	1 1/4 NPTF	6242
4243	5243	1 1/2 NPT/ANPT	6243
4244	5244	1 1/2 NPTF	6244
4245	5245	2 NPT/ANPT	6245
4246	5246	2 NPTF	6246

HOW TO ORDER Circular Chasers & Blocks

Please fill in below:

Qty. Ordered	EDP Number	Diameter	Pitch/TPI Thread Per Inch	Thread Form NC, NF, NS NPT, NPS ACME, etc.	Right or Left Hand	Die Head Size/Style	Number Per Set

GEOMETRIC CHASER System

RSVP Tooling now offers a comprehensive selection of thread cutting diehead options to consider for virtually any job lot size or application. We are proud to offer an economic solution to suit any requirement.

D Style dieheads are commonly used in automatic or manual operations, mounted in a fixed, stationary position in a turret or tool holder. Known as self opening type heads, they pull open when feed is stopped and are reset to the closed position by use of a reset lever actuated by hand or index of the machine.

DJ Style dieheads utilize the same chasers as D style heads and are made to withstand the same heavy duty applications. DJ heads are used where an opening type head is not mechanically supported or preferred. Referred to as solid adjustable type, DJ heads are suited to threading operations where reversing of the spindle is preferred such as in milling machines or lead screw controlled applications. They can be mounted in a fixed or rotating position.

Samn & Saman Style dieheads are a simple, durable design offering an attractive alternative to acorn type die chasers. Their one piece construction and ample thread size range offer an economic solution for short run applications and those with limited clearance. The SAMN style heads are a basic straight shank design whereas the SAMAN heads are offered with threaded bodies to screw directly onto standard #1 through #4 acorn holders.

Note: As is the case with all RSVP Tooling Dieheads, we can manufacture any head with customer specific requirements such as ground pilot bore, tap adapter fitting and virtually any shank configuration.

- D-Style - Overview & Components23 - 24
- DJ - Overview & Components25
- SAMN - Overview & Components26
- SAMAN - Overview & Components27
- Geometric Chaser Specs & Terms28 - 29
- How To Order Geometric Chasers29

D-STYLE Geometric Head

Self-Opening Stationary for Heavy Duty applications

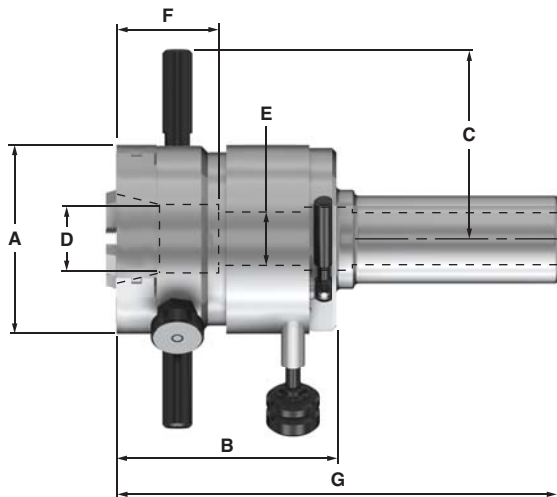

D-Style Geometric Head Dimensions

EDP	Size of Diehead	St. Thread Capacity	Pipe Capacity	Max The Length Solid Shank*	Std Shank Dia. **
7200	5/16 D	1/16 - 5/16	16-Jan	1.31	0.63
7201	9/16 D	1/8 - 9/16	1/16 - 1/4	1.5	1
7202	3/4 D	3/16 - 3/4	1/8 - 1/2	2.38	1.5
7207	1 D	1/4/01	1/8 - 3/4	2.5	1.5
7204	1-1/4 D	1/2 - 1-1/4	1/4/01	3	1.5
7219	1-1/2 D	5/8 - 1-1/2	3/8 - 1-1/4	3.63	1.5
7220	2 D	3/4/02	1/2 - 1-1/2	4.5	2
7221	2-1/2 D	1 - 2-1/2	3/4/02	4.5	2.5

EDP	Size of Diehead	A	B	C	D	E	F	G (OAL)
7200	5/16 D	1.77	2.11	1.89	0.49	0.39	0.38	3.74
7201	9/16 D	2.44	2.06	1.63	0.88	0.63	0.56	5.65
7202	3/4 D	2.94	3	1.94	1.13	0.81	1	6.84
7207	1 D	3.56	3.25	2.25	1.38	1.06	1.19	7.41
7204	1-1/4 D	4.94	3.81	2.94	1.75	1.31	1.19	8.45
7219	1-1/2 D	5.31	4.63	3.5	2.13	1.63	1.63	
7220	2 D	6.38	5.38	4.31	2.88	2.13	1.88	
7221	2-1/2 D	6.88	5.63	4.72	3.38	2.63	1.88	

Component Parts Breakdown Next Page

D-STYLE Component Parts Breakdown

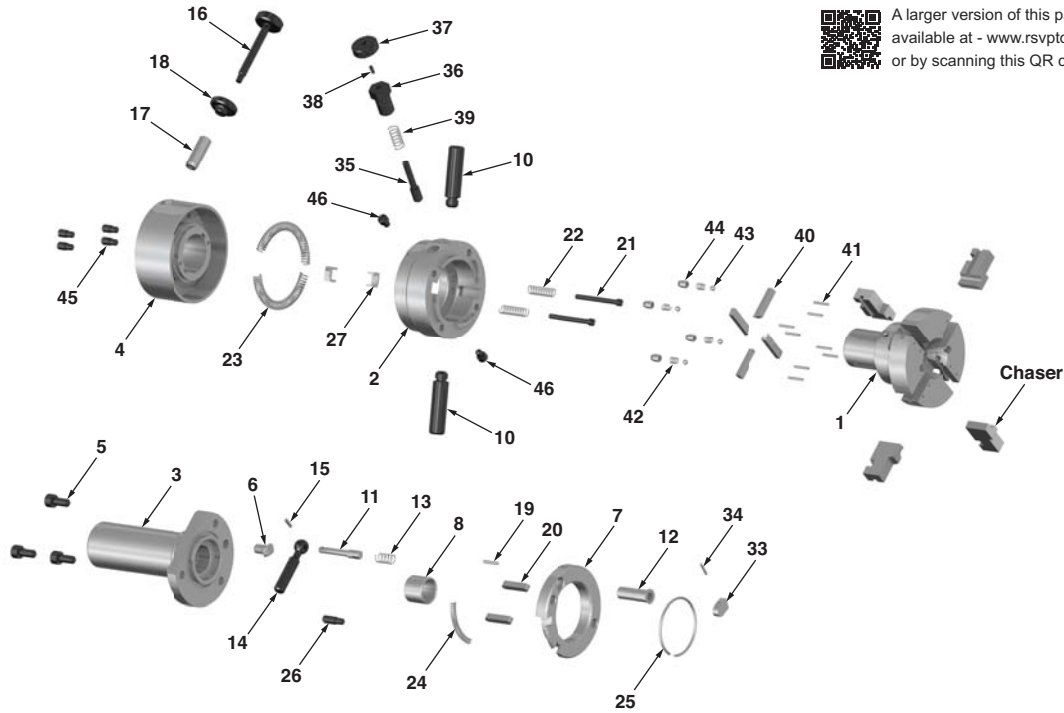

A larger version of this parts breakdown is available at - www.rsvptooling.com/prints.html or by scanning this QR code.

Item#	Description	Unit Reqd	5/16 EDP No.	9/16 EDP No.	3/4 EDP No.	1 EDP No.	1-1/4 EDP No.	1-1/2 EDP No.	2 EDP No.	2-1/2 EDP No.
1	Body	1	D1-001	D2-001	D3-001	D4-001	D5-001	D6-001	D7-001	D8-001
2	Cam	1	D1-002	D2-002	D3-002	D4-002	D5-002	D6-002	D7-002	D8-002
3	Shank	1	D1-003	D2-003	D3-003	D4-003	D5-003	D6-003	D7-003	D8-003
4	Flange	1	D1-004	D2-004	D3-004	D4-004	D5-004	D6-004	D7-004	D8-004
5	Allen Screw	3	D1-005	D2-005	D3-005	D4-005	D5-005	D6-005	D7-005	D8-005
6	Guide Pin for Shank	1	D1-006	D2-006	D3-006	D4-006	D5-006	D6-006	D7-006	D8-006
7	Adjusting Ring	1	D1-007	D2-007	D3-007	D4-007	D5-007	D6-007	D7-007	D8-007
8	Safety Bushing	1	D1-008	D2-008	D3-008	D4-008	D5-008	D6-008	D7-008	D8-008
10	Handle	2	D1-010	D2-010	D3-010	D4-010	D5-010	D6-010	D7-010	D8-010
11	Locking Pin	1	D1-011	D2-011	D3-011	D4-011	D5-011	D6-011	D7-011	D8-011
12	Sleeve	1	D1-012	D2-012	D3-012	D4-012	D5-012	D6-012	D7-012	D8-012
13	Sleeve Spring	1	D1-013	D2-013	D3-013	D4-013	D5-013	D6-013	D7-013	D8-013
14	Locking Pin Handle	1	D1-014	D2-014	D3-014	D4-014	D5-014	D6-014	D7-014	D8-014
15	Pin for Handle	1	D1-015	D2-015	D3-015	D4-015	D5-015	D6-015	D7-015	D8-015
16	Adjusting Screw	1	D1-016	D2-016	D3-016	D4-016	D5-016	D6-016	D7-016	D8-016
17	Threaded Bushing	1	D1-017	D2-017	D3-017	D4-017	D5-017	D6-017	D7-017	D8-017
18	Lock Nut	1	D1-018	D2-018	D3-018	D4-018	D5-018	D6-018	D7-018	D8-018
19	Pin for Threaded Bshg.	1	D1-019	D2-019	D3-019	D4-019	D5-019	D6-019	D7-019	D8-019
20	Key	2	D1-020	D2-020	D3-020	D4-020	D5-020	D6-020	D7-020	D8-020
21	Return Spring Screw	2	D1-021	D2-021	D3-021	D4-021	D5-021	D6-021	D7-021	D8-021
22	Return Spring	2	D1-022	D2-022	D3-022	D4-022	D5-022	D6-022	D7-022	D8-022
23	Opening Spring	2	D1-023	D2-023	D3-023	D4-023	D5-023	D6-023	D7-023	D8-023
24	Adjusting Spring	1	D1-024	D2-024	D3-024	D4-024	D5-024	D6-024	D7-024	D8-024
25	Locking Ring	1	D1-025	D2-025	D3-025	D4-025	D5-025	D6-025	D7-025	D8-025
26	Screw for Flange	1	D1-026	D2-026	D3-026	D4-026	D5-026	D6-026	D7-026	D8-026
27	Pad for Opening Spring	2	D1-027	D2-027	D3-027	D4-027	D5-027	D6-027	D7-027	D8-027
33	Segment	1	D1-033	D2-033	D3-033	D4-033	D5-033	D6-033	D7-033	D8-033
34	Segment Pin	1	D1-034	D2-034	D3-034	D4-034	D5-034	D6-034	D7-034	D8-034
35	Indexing Pin	1	D1-035	D2-035	D3-035	D4-035	D5-035	D6-035	D7-035	D8-035
36	Indexing Sleeve	1	D1-036	D2-036	D3-036	D4-036	D5-036	D6-036	D7-036	D8-036
37	Indexing Head	1	D1-037	D2-037	D3-037	D4-037	D5-037	D6-037	D7-037	D8-037
38	Pin for In design Head	1	D1-038	D2-038	D3-038	D4-038	D5-038	D6-038	D7-038	D8-038
39	Indexing Spring	1	D1-039	D2-039	D3-039	D4-039	D5-039	D6-039	D7-039	D8-039
40	Chaser Key	4	D1-040	D2-040	D3-040	D4-040	D5-040	D6-040	D7-040	D8-040
41	Pin for Chaser Key	8	D1-041	D2-041	D3-041	D4-041	D5-041	D6-041	D7-041	D8-041
42	Pressure Nipple Spring	4	D1-042	D2-042	D3-042	D4-042	D5-042	D6-042	D7-042	D8-042
43	Ball	4	D1-043	D2-043	D3-043	D4-043	D5-043	D6-043	D7-043	D8-043
44	Pressure Nipple	4	D1-044	D2-044	D3-044	D4-044	D5-044	D6-044	D7-044	D8-044
45	Cam Screw	4	D1-045	D2-045	D3-045	D4-045	D5-045	D6-045	D7-045	D8-045
46	Screw for Body	2	D1-046	D2-046	D3-046	D4-046	D5-046	D6-046	D7-046	D8-046

DJ Geometric Head

Durable Solid Adjustable for repeating tap style external threading

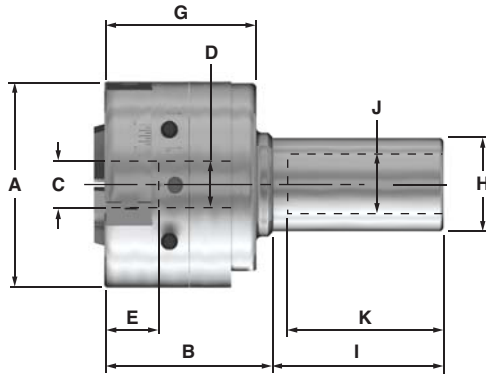

DJ Geometric Head Dimensions

EDP	Size of Diehead	St. Thread Capacity	Pipe Capacity	Max The Length Solid Shank*	A	B	C
7208	5/16 DJ	1/16 - 5/16	1/16 - 1/8	0.56	1.63	1	0.5
7211	9/16 DJ	1/8 - 9/16	1/16 - 1/4	0.81	2.44	1.38	0.88
7212	3/4 DJ	3/16 - 3/4	1/8 - 1/2	1.13	2.92	1.75	1.06
7213	1 DJ	1/4/01	1/8 - 3/4	1.25	3.56	2	1.44
7214	1-1/4 DJ	1/2 - 1-1/4	1/4/01	1.5	3.88	2.25	1.69
7215	1-3/4 DJ	5/8 - 1-1/2	3/8 - 1-1/4	1.63	4.5	2.38	2.19
7216	2-1/4 DJ	3/4/02	1/2 - 1-1/2	1.63	4.94	2.38	2.69
7217	2-1/2 DJ	1 - 2-1/2	3/4/02	1.75	5.75	2.75	3
7218	3 DJ	1-1/2 - 3	1-1/4 - 2	1.63	5.88	2.38	3.44
7219	3-3/4 DJ	2-1/8 - 3-3/4	3-Feb	1.63	6.5	2.38	4.19
7220	4-3/4 DJ	2-7/8 - 4-3/4	2-1/2 - 4	1.75	8.25	2.75	5.25

EDP	Size of Diehead	D	E	G	H	I	J	K
7208	5/16 DJ	0.5	—	0.94	0.88	2	—	—
7211	9/16 DJ	0.81	0.56	1.13	1	2.5	0.93	1.5
7212	3/4 DJ	1	0.81	1.5	1.25	3	0.93	1.5
7213	1 DJ	1.31	1.06	1.63	1.5	3.5	0.93	1.5
7214	1-1/4 DJ	1.56	0.94	1.88	2	3.75	1.1	1.5
7215	1-3/4 DJ	2.06	0.94	2	2.5	4	1.1	1.5
7216	2-1/4 DJ	2.56	0.94	2	3	4.25	1.1	1.5
7217	2-1/2 DJ	2.88	1.19	2.25	3.5	4.75	1.75	1.5
7218	3 DJ	3.31	0.94	2.25	4	4.75	1.75	1.5
7219	3-3/4 DJ	4.06	0.94	2.25	4.75	5	1.75	1.5
7220	4-3/4 DJ	5.13	1.19	2.25	5	5.5	1.75	1.5

Component Parts Breakdown

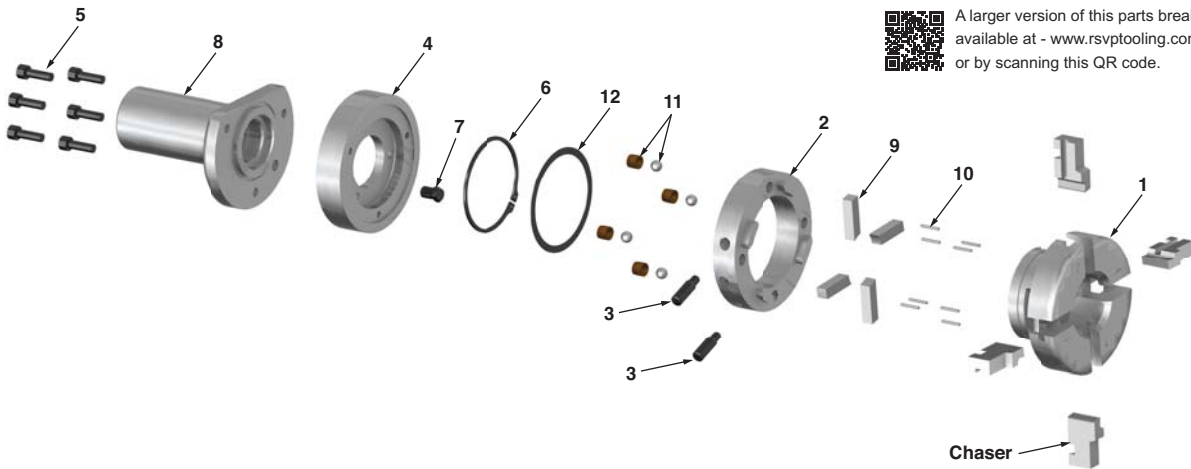

A larger version of this parts breakdown is available at - www.rsypooling.com/prints.html or by scanning this QR code.

Item#	Description	Unit Reqd	5/16 EDP No.	9/16 EDP No.	3/4 EDP No.	1 EDP No.	1-1/4 EDP No.	1-3/4 EDP No.	2-1/4 EDP No.	2-1/2 EDP No.	3 EDP No.	3-3/4 EDP No.	4-3/4 EDP No.
1	Body	1	DJ1-001	DJ2-001	DJ3-001	DJ4-001	DJ5-001	DJ6-001	DJ7-001	DJ8-001	DJ9-001	DJ10-001	DJ11-001
2	Cam	1	DJ1-002	DJ2-002	DJ3-002	DJ4-002	DJ5-002	DJ6-002	DJ7-002	DJ8-002	DJ9-002	DJ10-002	DJ11-002
3	Adjusting Screw	1	DJ1-003	DJ2-003	DJ3-003	DJ4-003	DJ5-003	DJ6-003	DJ7-003	DJ8-003	DJ9-003	DJ10-003	DJ11-003
4	Flange	1	DJ1-004	DJ2-004	DJ3-004	DJ4-004	DJ5-004	DJ6-004	DJ7-004	DJ8-004	DJ9-004	DJ10-004	DJ11-004
5	Allen Screw	6	DJ1-005	DJ2-005	DJ3-005	DJ4-005	DJ5-005	DJ6-005	DJ7-005	DJ8-005	DJ9-005	DJ10-005	DJ11-005
6	Circlip	1	DJ1-006	DJ2-006	DJ3-006	DJ4-006	DJ5-006	DJ6-006	DJ7-006	DJ8-006	DJ9-006	DJ10-006	DJ11-006
7	Guide Pin	1	DJ1-007	DJ2-007	DJ3-007	DJ4-007	DJ5-007	DJ6-007	DJ7-007	DJ8-007	DJ9-007	DJ10-007	DJ11-007
8	Modular Shank	1	DJ1-008	DJ2-008	DJ3-008	DJ4-008	DJ5-008	DJ6-008	DJ7-008	DJ8-008	DJ9-008	DJ10-008	DJ11-008
9	Chaser Key		DJ1-009	DJ2-009	DJ3-009	DJ4-009	DJ5-009	DJ6-009	DJ7-009	DJ8-009	DJ9-009	DJ10-009	DJ11-009
10	Pin for Chaser Key	2	DJ1-010	DJ2-010	DJ3-010	DJ4-010	DJ5-010	DJ6-010	DJ7-010	DJ8-010	DJ9-010	DJ10-010	DJ11-010
11	Nipple Assembly	1	DJ1-011	DJ2-011	DJ3-011	DJ4-011	DJ5-011	DJ6-011	DJ7-011	DJ8-011	DJ9-011	DJ10-011	DJ11-011
12	Washer	1	DJ1-012	DJ2-012	DJ3-012	DJ4-012	DJ5-012	DJ6-012	DJ7-012	DJ8-012	DJ9-012	DJ10-012	DJ11-012

SAMN Geometric Head

Compact solid adjustable for limited clearance applications



Head EDP	Size	Head EDP	Size	Head EDP	Size	Head EDP	Size
7300	0	7302	17/32-3/4	7304	1-1/32-1-1/4	7306	1-17/32-1-3/4
7301	0-1/2	7303	25/32-1	7305	1-9/32-1-1/2	7307	1-25/32-2

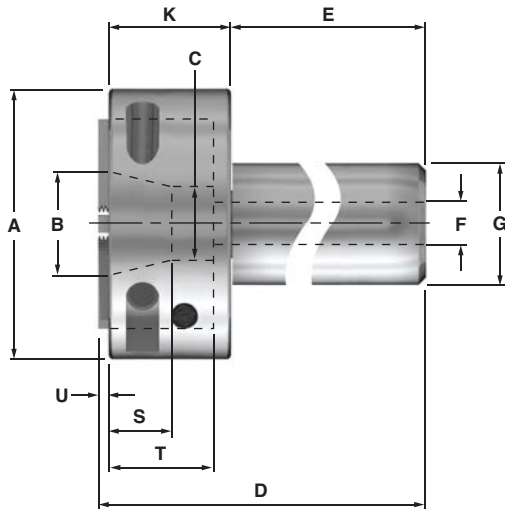

SAMN Geometric Head Dimensions

EDP	Size of Diehead		A	B	C	D	E
7300	0	IN.	1.75	0.62	0.41	2.77	1.69
7301	0-1/2	IN.	2.22	0.69	0.56	5.12	4
7302	17/32-3/4	IN.	2.5	0.94	0.81	5.25	4
7303	25/32-1	IN.	2.88	1.19	1.06	5.25	4
7304	1-1/32-1-1/4	IN.	3.13	1.44	1.31	5.25	4
7305	1-9/32-1-1/2	IN.	3.38	1.69	1.56	5.25	4
7306	1-17/32-1-3/4	IN.	3.63	1.81	1.81	5.25	4
7307	1-25/32-2	IN.	3.88	2.06	2.06	5.25	4

EDP	Size of Diehead	F	G	K	S	T	U
7300	0	0.41	0.63	1.02	0.56	0.83	0.06
7301	0-1/2	0.56	1	1	0.5	0.81	0.12
7302	17/32-3/4	0.5	1.25	1.12	0.5	0.94	0.12
7303	25/32-1	0.5	1.5	1.12	0.5	0.94	0.12
7304	1-1/32-1-1/4	0.5	1.5	1.12	0.5	0.94	0.12
7305	1-9/32-1-1/2	0.5	1.5	1.12	0.5	0.94	0.12
7306	1-17/32-1-3/4	0.75	2	1.12	—	0.94	0.12
7307	1-25/32-2	0.75	2	1.12	—	0.94	0.12

Component Parts Breakdown

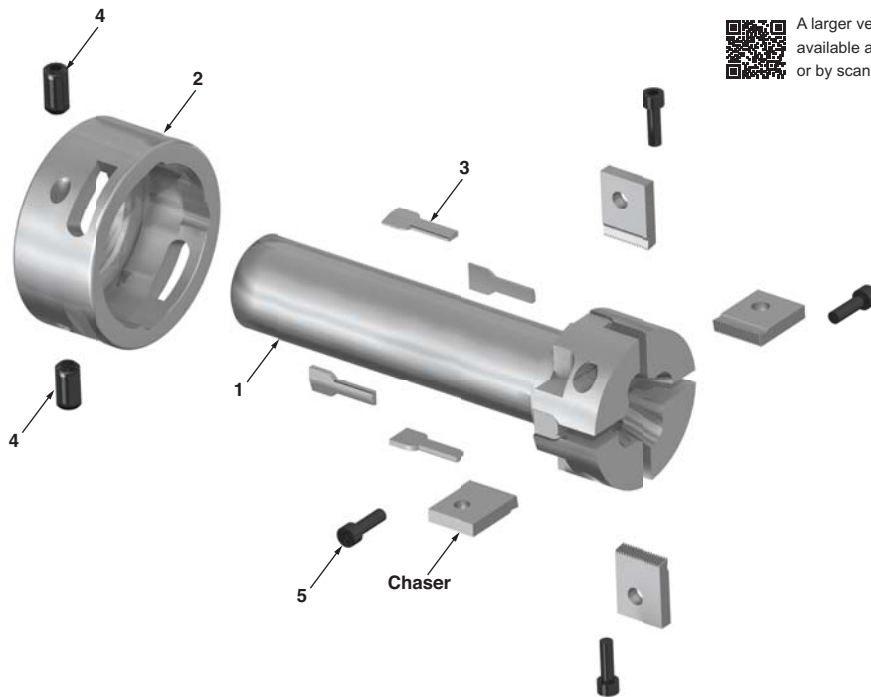

A larger version of this parts breakdown is available at - www.rsypooling.com/prints.html or by scanning this QR code.

Item#	Description	Unit Reqd	0		0-1/2		17/32-3/4		25/32-1		1-1/32-1-1/4		1-9/32-1-1/2		1-17/32-1-3/4		1-25/32-2	
			EDP No.	EDP No.	EDP No.	EDP No.	EDP No.	EDP No.	EDP No.	EDP No.	EDP No.	EDP No.	EDP No.	EDP No.	EDP No.			
1	Body assembly	1	S1693	S2372	S2374	S2376	S2378	S2380	S2382	S2384								
2	Cup assembly	1	S1694	S2373	S2375	S2377	S2379	S2381	S2383	S2385								
3	Chaser Insert	4	S1706	S2415	S2419	S2419	S2419	S2419	S2419	S2419								
4	Adjusting Screw	2	S1707	S1707	S2420	S2424	S2428	S2428	S2428	S2428								
5	Chaser Screw	4	S1708	S2416	S2421	S2425	S2429	S2429	S2434	S2434								

SAMAN Geometric Head

Compact simple design perfect for replacement of acorn die systems



Head EDP	Size	Head EDP	Size	Head EDP	Size	Head EDP	Size
7300-A	0	7302-A	17/32-3/4	7304-A	1-1/32-1-1/4	7306-A	1-17/32-1-3/4
7301-A	0-1/2	7303-A	25/32-1	7305-A	1-9/32-1-1/2	7307-A	1-25/32-2

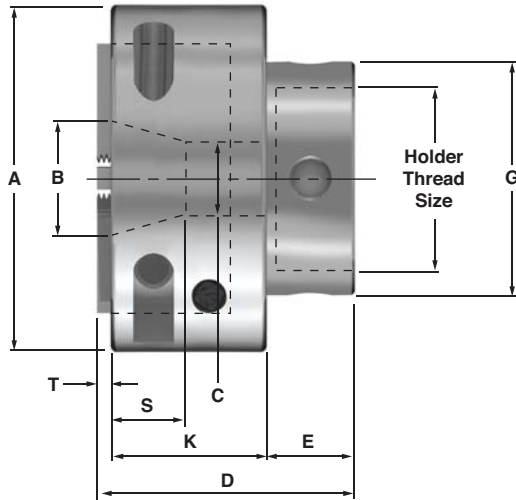

SAMAN Geometric Head Dimensions

EDP	Size of Diehead	A	B	C	D	E
7300-A	0	IN. 1.75	0.62	0.41	1.56	0.48
7301-A	0-1/2	IN. 2.22	0.69	0.56	1.69	0.56
7302-A	17/32-3/4	IN. 2.5	0.94	0.81	2	0.75
7303-A	25/32-1	IN. 2.88	1.19	1.06	2	0.75
7304-A	1-1/32-1-1/4	IN. 3.13	1.44	1.31	2	0.75
7305-A	1-9/32-1-1/2	IN. 3.38	1.69	1.56	2	0.75
7306-A	1-17/32-1-3/4	IN. 3.63	1.81	1.62	2	0.75
7307-A	1-25/32-2	IN. 3.88	2.06	1.56	2	0.75

EDP	Size of Diehead	G	K	S	T	Acorn Holder #	Thread Size
7300-A	0	1.25	1.02	0.56	0.06	#2	1.0 x 20
7301-A	0-1/2	1.5	1	0.5	0.12	#2	1.0 x 20
7302-A	17/32-3/4	1.88	1.12	0.5	0.12	#3	1.5 x 20
7303-A	25/32-1	2	1.12	0.5	0.12	#3	1.5 x 20
7304-A	1-1/32-1-1/4	2.38	1.12	0.5	0.12	#3	1.5 x 20
7305-A	1-9/32-1-1/2	2.38	1.12	0.5	0.12	#4	1.875 x 20
7306-A	1-17/32-1-3/4	2.5	1.12	0.5	0.12	#4	1.875 x 20
7307-A	1-25/32-2	2.75	1.12	0.5	0.12	#4	1.875 x 20

Component Parts Breakdown

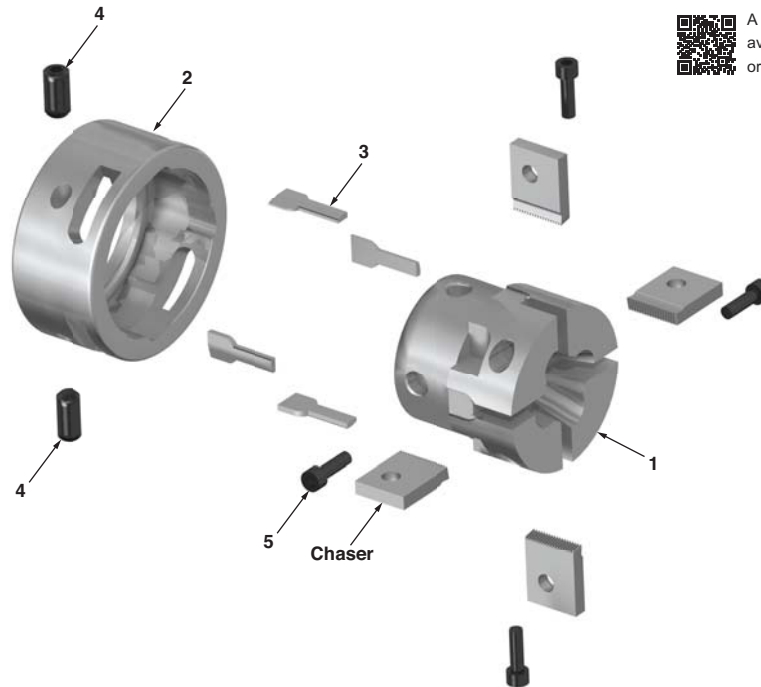

A larger version of this parts breakdown is available at - www.rsvptooling.com/prints.html or by scanning this QR code.

Item#	Description	Unit Reqd	0	0-1/2	17/32-3/4	25/32-1	1-1/32-1-1/4	1-9/32-1-1/2	1-17/32-1-3/4	1-25/32-2
			EDP No.	EDP No.	EDP No.	EDP No.	EDP No.	EDP No.	EDP No.	EDP No.
1	Body assembly	1	S1704	S2413	S2417	S2422	S2426	S2430	S2432	S2435
2	Cup assembly	1	S1705	S2414	S2418	S2423	S2427	S2431	S2433	S2436
3	Chaser Insert	4	S1706	S2415	S2419	S2419	S2419	S2419	S2419	S2419
4	Adjusting Screw	2	S1707	S1707	S2420	S2424	S2428	S2428	S2428	S2428
5	Chaser Screw	4	S1708	S2416	S2421	S2425	S2429	S2429	S2434	S2434

GEOMETRIC Chaser Specs & Terms

Geometric Chaser Parts

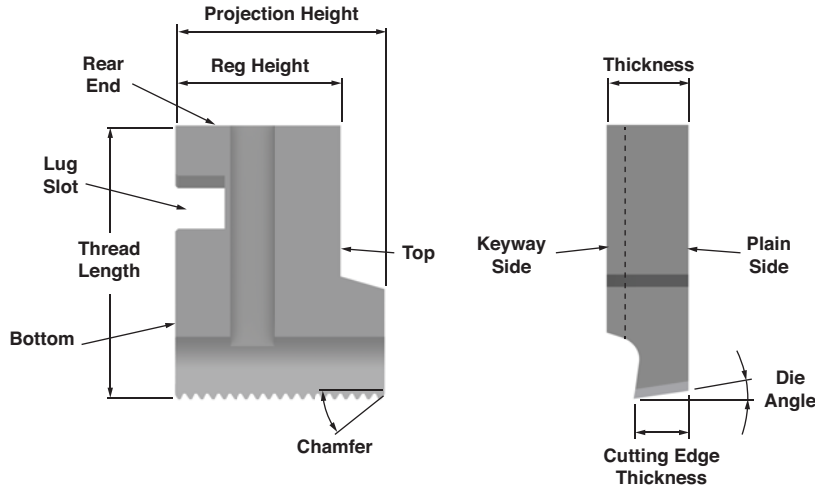

For Milled, Supermetric, Ground and Tapped Form

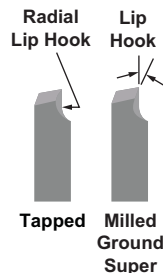
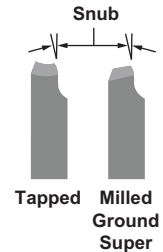
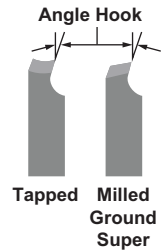
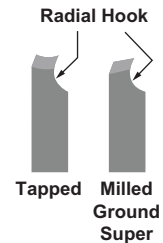
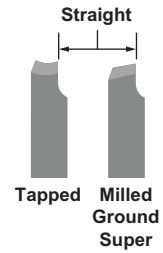

Geometric Chaser Grinding Chart

	Die Head Chasers		S-Tap Chasers	
	Milled-Thread	Ground-SUPER-Tapped	Ground	Taper Thread
Aluminum:				
Cast, Die, Cast, Rod, or Stamping	15° Radial hook	10° Radial Hook	20° Radial Hook	20° radial hook
Bakelite:	5° snub	5° snub	5° hook	5° hook
Brass:				
Bar	5° hook	straight	5° hook	5° hook
Cast	5° snub	5° hook	5° hook	5° hook
Forging, Stamping, Tubing, or Naval	10° hook	5° hook	10° hook	10° hook
Bronze:				
Bar, Cast, Aluminum, Manganese, Naval, Phosphor, Tubing	10° hook	5° hook	10° hook	10° hook
Cast	Straight	straight	10° hook	10° hook
Celluloid:	straight	straight	5° hook	5° hook
Copper:	15° radial lip hook	10° Radial Hook	20° lip hook	20° radial hook
Everdur:	10° hook	10° hook	10° hook	10° hook
Fibre:	5° snub	5° snub	5° hook	5° hook
Iron:				
Cast	straight	straight	5° hook	5° hook
Malleable, Wrought	10° hook	5° hook	10° hook	10° hook
Magnesium:	15° radial hook	20° radial hook	20° radial hook	20° radial hook
Monel Metal:	10° hook	5° hook	10° hook	10° hook
Nickel:	15° hook	10° hook	20° lip hook	15° radial hook
Rubber:	5° snub	5° snub	5° hook	5° hook
Silver:				
German	10° hook	5° hook	10° hook	10° hook
Steel:				
Bessmr, Scr. Stock, Cast, Carb.				
SAE 1010-1035, SAE 1112-X1340	10° hook	5° hook	10° hook	10° hook
Carb. SAE 1040-1095				
Mang. SAE T1330-T1350				
Chrome SAE 5120-52100				
Chrome Van SAE 6115-6195				
Molybdenum SAE 5130-4820				
Nickle SAE 2015-2515				
Nitalloy Ni-Chrome SAE 3115-3450				
Stainless, Tool, Forging	15° hook	10° hook	20° hook	15° radial hook
Stamping, Tubing	15° hook	5° hook	20° hook	15° radial hook
Semi-casting	straight	straight	5° hook	5° hook
Zinc:				
Die Casting	15° radial hook	10° Radial Hook	20° Radial Hook	20° radial hook

For Right and Left Hand Tap Chasers

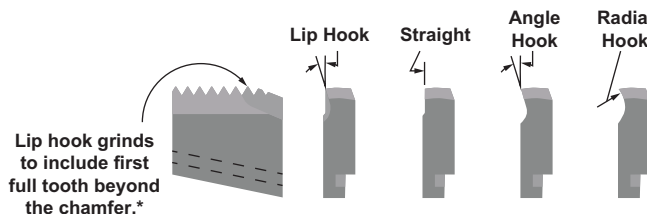

Lip hook grinds to include first full tooth beyond the chamfer.*

*Lip hook grinds not recommended for shoulder or bottoming work. Use the same angle but omit the lip.

Terms Related to Geometric Chasers

Bearing

This is the surface in contact between the Chaser and the work when cutting the thread.

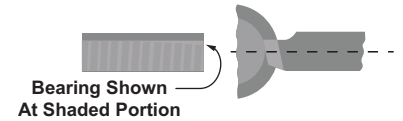

Circumferential Clearance

(Tapped Form and S Chasers)

To provide relief circumferentially between chasers and work as shown so that the chasers will contact the work at the cutting face only.

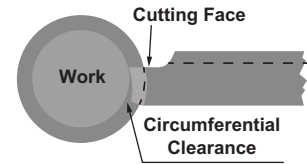

Die Angle

(Milled, Ground thread, or Tapped Form Chasers)

Relief between the chaser and the work is provided by the Die Angle, i.e., the angle at which the threads are milled.

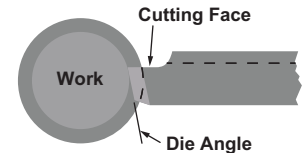

Longitudinal Clearance

(Milled, Ground thread, or Tapped Form Chasers)

To provide clearance longitudinally between the chaser and the work as shown so all the cutting will be done at the chamfer.

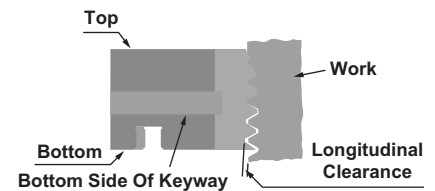

Move (Single Thread)

The distance or advance of a given thread from chaser to chaser is the "MOVE". The distance is the same from one chaser to the next in a set (on single thread).

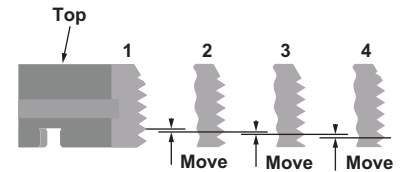

Tracking

Chasers "track" properly when all chasers of a set follow exactly in the groove cut by the preceding chaser or chasers.

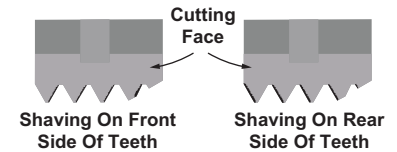

Shaving

Shaving is the side cutting action of one or more chasers resulting in thin threads.

HOW TO ORDER Geometric Chasers

For D-Style and DJ Geometric chasers please fill in below:

Qty. Ordered	EDP Number	Diameter	Pitch/TPI Thread Per Inch	Thread Form NC, NF, NS NPT, NPS ACME, etc.	Righ or Left Hand	Type Milled Ground Supermetric Tapped Form	Chamfer 45, 33 22, 15, ect. Degrees	Projection O'hanging Regular Style	Die Head or Tap Size/Style	Construction No. or Serial Numbers	Face Grind Hook Str, Neg 5, 5P, 10P, 15P ect.	Material to Be Cut Steel, Brass Alum, ect.	Coating

For SAMN and SAMAN Geometric chasers please fill in below:

Qty. Ordered	EDP Number	Diameter	Pitch/TPI Thread Per Inch	Thread Form NC, NF, NS NPT, NPS ACME, etc.	Righ or Left Hand	Series 00 100, 200	Number Per set	Blank Width	Chamfer 45, 35 25, ect. Degrees	Die Head Size/Style	Face Grind Hook Str, Neg 5, 5P, 10P, 15P ect.	Material to Be Cut Steel, Brass Alum, ect.	Coating

AXIAL Thread Rolling

For producing long threads, or threads without run-out restriction, then RSVP axial rolling heads are the ideal selection. Axial heads feed on from the end of the part and require one revolution of the spindle for each pitch of thread to be produced. Controlled forward axial motion, either by cam or CNC feed, are recommended although manually operated lathes can also give excellent results. RSVP axial heads are self opening and normally require an external closing action to reset them for the next pass. Right hand rolling heads are required for rolling right hand threads and the spindle direction must also be right hand. Left hand threads require corresponding heads and spindle rotation.

How To Order

Selecting The Correct Thread Rolling Head

There are two main factors that govern the choice of thread rolling head:

1. The thread size has to be within the standard capacity of the thread rolling head.
2. There must be sufficient clearance within the machine for the head to operate.

On pages 34 to 47 the range of axial thread rolling heads is illustrated, showing the outline dimensions and standard thread sizes for each head. Left hand and rotating versions of these heads are available in all the standard sizes. Special high-helix heads can also be supplied to accommodate Acme and multi-start threads.

Example:

In order to produce a 7/16 - 14 UNC stud, there is a choice between the A1, A2 and A3 heads. This choice may be limited by the clearance on the machine so it is most important to know the maximum diameter and projection available. If the maximum diameter that will clear when the machine turret indexes is 3.75", then the A3 head, at 4.60" diameter, is no longer a viable option. The choice between the A1 or the A2 should then be made with consideration given to any other threads that may need to be produced on the chosen head. If 7/16 UNC is the maximum thread size required then the A1, with a range of 1/4 UNC up to 7/16 UNC would be the recommended choice. However, if thread sizes above 7/16 UNC are required then the A2, with a range of 5/16 UNC up to 5/8 UNC, should be selected. Having selected the appropriate thread rolling head, please specify the required shank diameter from the options available.

RSVP Thread Rolling System Advantages	31
Thread Rolling Introduction	32
Applications	33
A0 - Overview & Components	34
A001 - Overview & Components	35
A01 - Overview & Components	36
A1 - Overview & Components	37
A12 - Overview & Components	38
A2 - Overview & Components	39
A23 - Overview & Components	40
A233400 - Overview & Components	41
A3 - Overview & Components	42
A34 - Overview & Components	43
A4 - Overview & Components	44
A45 - Overview & Components	45
A5 - Overview & Components	46
A56 - Overview & Components	47
Operation.....	48 - 50
Problem Solving	51
Lead Angles	52 - 54
Recommended Blank Diameters.....	55 - 57
Rolling Speeds	58

Selecting Thread Rolls

When ordering thread rolls it is important to specify as much information as possible about the rolls and the application so that the correct rolls may be promptly supplied. The minimum details required are as follows:

The full thread specification (e.g. 3/8 - 16 UNC, 7/16 - 20 UNF, 1/2 - 14 NPSM, 1/4 - 19 BSP)

The thread rolling head for which the rolls are required (A1, A23, A01 Etc.)

The lead required on the rolls (1K standard short lead, 2K standard long lead, or other special lead)

Using the 7/16 - 14 UNC stud example, to be produced using the A2 head, the final order would read as follows:

Quantity	Description
1	A2 THREAD ROLLING HEAD, 1" DIAMETER SHANK
2 SETS	7/16 - 14 UNC ROLLS WITH 2K LEAD, TO SUIT A2 HEAD

Should there be any doubt about the type of lead required on the rolls, or the size of head to be used, please provide our technical department with a component drawing so that we may make our own recommendations. Test samples may be produced with customer's material on special request.

THREAD ROLLING Advantages

Advantages To Using An RSVP Thread Rolling System

Thread rolling is now recognized as the fastest and most reliable method of producing quality threads, with RSVP axial and tangential heads and rolls at the forefront of this technology.

The introduction of radial thread rolling offers a new dimension to users of this process, and means thread production can be measured in fractions of a second!

The applications for RSVP thread rolling heads are almost limitless, with models available to suit virtually every type of lathe in the industry.

Technical support

It should be noted that many of the features of thread rolling are shared by axial, tangential and radial rolling heads. Customers are advised to contact our technical department for assistance in selecting the appropriate equipment.

RSVP enjoy the advantage of a dedicated manufacturing facility that offers the customer unrivaled technical support and know-how across a full range of thread rolling and thread cutting products. This expertise applies throughout our thread rolling program and is available to all our customers in North America.

The Benefits Of Thread Rolling

In order to select the appropriate rolling head, it is important to understand the principles of thread rolling.

The cold forming rolling process produces threads by plastic deformation of the material. This in turn imparts high strength plus excellent surface finish, combined with improved wear and corrosion resistance.

As a result, rolled threads are indispensable to safety critical applications in the aerospace, nuclear and automotive industries.

The high rates of material deformation required to roll threads have a most beneficial consequence; very short cycle times. Compare thread rolling with other widely used methods and the potential savings in time and cost are self evident. Figure 1 illustrates the time saving over single point as 7.2 seconds per thread. Multiply this by over 200,000 parts per annum to give a total time saving of 400 hours. This equates to 10 extra weeks of valuable machine time!

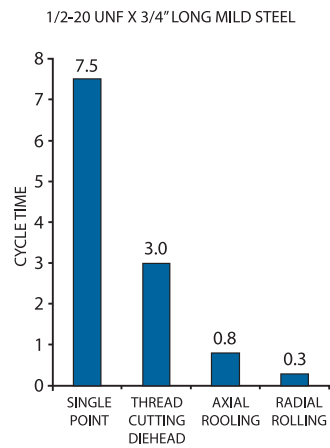

Figure: 1

Axial, Tangential Or Radial?

Before choosing the optimum rolling system, there are certain criteria that must be met:

- a. **Material** - for axial rolling should have minimum elongation of 5% and the tensile strength should not exceed 1700 N/mm². However, 8% elongation and 1000 N/mm² are preferred for radial rolling.
- b. **Spindle** - should be fast enough to permit rolling speeds of 60-180 sfm when axial thread rolling and 60-90 sfm when radial rolling. The work piece must always be on the same center line as the rolling head.
- c. **Power** - available power for rolling at high speeds is essential. Radial rolling requires additional torque to axial and tangential rolling as the process is completed in just one revolution of the rolls.

INTRODUCTION to Axial Thread Rolling

Description

The thread rolling process is now widely acknowledged as the fastest and most efficient method of producing accurate external threads, with surface finish and mechanical properties unobtainable by any other method.

This simple cold forming operation enables engineers to produce threaded fasteners and components to the most exacting standards with ease and repeatability on a wide range of materials. In fact, many high tensile and safety critical components, such as used in the aerospace industries, demand a rolled thread for its high strength properties and no other threading method will be accepted in these cases.

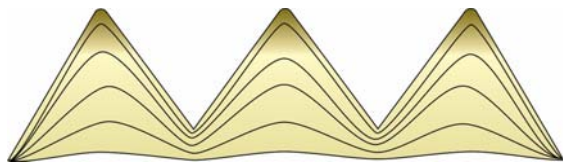

Figure 1: Grain structure of rolled thread



Figure 2: Grain structure of cut thread

The properties of a rolled thread are best illustrated by examining the cross section of a thread that has been produced by thread rolling and comparing it to a thread that has been produced by conventional cutting.

The rolled thread form does not break through the grain of the material as occurs with a cut thread and is subsequently more resistant to fracture during tensile loading. The compressive action that takes place during thread rolling serves to increase the hardness of the material, improve its tensile and yield strengths due to the burnishing action of rolling. As a result, thread rolling gives a highly polished finish that resists surface corrosion.

Axial Thread Rolling

The thread rolling heads detailed on pages 34 - 47 of this catalog all function by means of axial or end feeding. This process requires the head to be applied to the end of a prepared blank at a controlled feed rate so that the lead on the thread rolls engage with the lead chamfer on the blank. Once the rolls have engaged with the blank the head will feed itself axially along the part until it reaches the end of its stroke. At this point the forward motion of the head is arrested and the pull off mechanism operates to open the head so that the rolls clear the thread and the head can then be retracted from the part. Due to the self feeding action of the head, it is equally suited to machines without a feed control mechanism as well as machines with lead screws or CNC controlled slides.

On manual type machines the head is reset by the operator before each threading pass using the standard handle equipped with the head. The same method is used when the head is mounted into the turret of a CNC chucking lathe. When operated under automatic cycle on either cam or CNC bar autos, the manual ball type handle is replaced by a closing pin which has to be actuated by an external closing lever or strike plate mounted at the indexing position of the machine turret (the same principle as a conventional diehead). Some machine tool manufacturers offer separate pneumatic actuating units which are ideally suited to closing thread rolling heads.



AXIAL Application

Applications

Axial thread rolling heads have an established reputation for reducing thread cycle times and increasing productivity on a wide range of conventional and CNC controlled machines. The nature of thread-rolling, being up to four times faster than traditional cutting methods, requires the machine tool to be able to run at much higher speeds which can place limitations on older lathes and cam autos that were designed for cutting at lower speeds and feeds. The widespread use of CNC lathes with their elevated spindle speeds and accurate programmable feed rates has helped to increase the potential applications for axial thread rolling heads, especially on smaller diameter threading where single point methods are slower and less accurate. High resolution programming to .0001" (.001mm) enables pre-rolling blank diameters to be maintained more accurately on CNC lathes which is advantages when producing threads to tight tolerances.

The basic criteria for selecting a machine for thread rolling are as follows:

Spindle Speed: The machine spindle must be capable of rotating at the speed required for the thread to be rolled.

Feed Control: Automatic machines should be equipped with a controllable feed mechanism that allows a smooth start to the rolling process and a positive, accurate stop mechanism for reliable opening of the head. On both manual and automatic machines, a heavy or sticking slide will not allow the self-feeding of the head to function correctly and premature opening of the head will result. Over feeding of the head will cause damage both to the start threads on the piece part as well as the rolls and must be avoided.

Alignment: As with all on center end working tools, it is essential that the machine spindle and the head are not misaligned, as this can result in malformed threads, shortened roll life and in severe cases breakage to the thread rolling head.

Coolant: An adequate supply of good quality, particle-free coolant should be obtainable from the machine coolant system.

If the basic criteria outlined above are met, then successful thread rolling can be achieved on most types of turning machines, including CNC lathes, multi-spindle screw machines, single-spindle screw machines, turret lathes, centre lathes and special purpose threading machines.

Material Properties

Axial thread rolling proves most successful on materials that have an elongation of 10% or more and a tensile strength of below 1500N/mm² (140,000 psi). It is often possible to roll materials outside these parameters, but the life of the thread rolls can be so reduced as to make the process uneconomic. Certain free cutting grades of steel and brass may have low tensile strengths and good elongation factors but are often susceptible to flaking at the root and flanks of the thread, especially on Acme, trapezoidal and coarse v-form threads. For these applications, it is advisable to obtain material grades that offer good machinability combined with a low lead content.

The following chart gives an indication of the types of materials that can be thread rolled using an axial head, combined with the recommended rolling speeds for standard v-form threads:

	feet/min	meters/min
Low - medium carbon steels	100 - 200	30 - 60
Medium case hardening steels	100 - 200	30 - 60
High alloy steels	120 - 250	35 - 75
Stainless steels	120 - 225	35 - 70
Copper alloys	200 - 300	60 - 90

As a guide, coarse pitches and high tensile materials are rolled at the lower end of the above speed ranges. Fine pitches and light alloys may be rolled at the top end of the above speed ranges.



Standard HSS Thread Rolls



Nitrided HSS Thread Rolls

AO Axial Head

EDP	Shank
7101	3/4
7101-20	20mm

Approximate Weight: 1.2 lbs

Axial Thread Rolling Heads For Right Hand Threads For Stationary Applications

AO Axial Head Dimensions

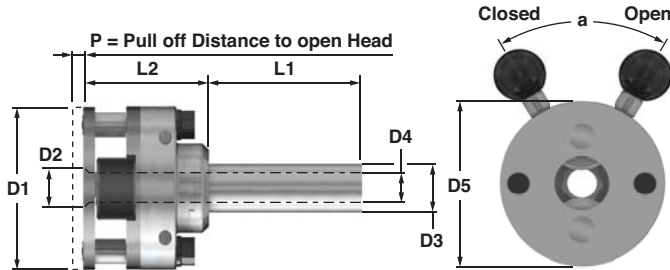

Dimensions

	D1	D2	D3	D4	D5 max
Helix Angle in Head = 4°					
Allowable Component Lead	inches	1.970	0.453	3/4	0.260
Angle = 2° 25' - 5° 12'	mm	50	11.5	20	6.5

Dimensions Continued

	L1	L2	P	a
Helix Angle in Head = 4°				
Allowable Component Lead	inches	1.970	1.520	0.080
Angle = 2° 25' - 5° 12'	mm	50	39	2

Left hand heads are dimensionally the same as right hand heads but open and close on the opposite direction. Thread rolls can be used in both right hand and left hand heads.

The Following Thread Rolls May Be Ordered As Standard On The AO Axial Head

ISO Metric		
1K EDP	2K EDP	Description
8101	8102	M1.4 x 0.3
8103	8104	M1.6 - 1.8 x .035
8105	8106	M2.0 - 2.3 x 0.4
8107	8108	M2.2 - 2.6 x 0.45
8109	8110	M2.5 - 3.0 x 0.5
8111	8112	M3.0 - 3.5 x 0.6
8113	8114	M4 x .07
8115	8116	M4.0 - 4.5 x 0.75
8117	8118	M5 x 0.8
8119	8120	M5.0 - 5.5 x 0.9

Unified Coarse UNC		
1K EDP	2K EDP	Description
8121	8122	No. 1 x 64
8123	8124	No. 2 x 56
8125	8126	No. 3 x 48
8127	8128	No. 4 - 5 x 40
8129	8130	No. 6 - 8 x 32
8131	8132	No. 10 - 12 x 24

Unified Fine UNF		
1K EDP	2K EDP	Description
8133	8134	No. 0 x 80
8135	8136	No. 1 x 72
8137	8138	No. 2 x 64
8139	8140	No. 3 x 56
8141	8142	No. 4 x 48
8143	8144	No. 5 x 44
8145	8146	No. 6 x 40
8147	8148	No. 8 x 36
8149	8150	No. 10 x 32
8151	8152	No. 12 x 28

Threads outside of the above standard series may also be rolled on this head provided that their helix does not fall outside the permissible range.

Nitrided Rolls are available for use in rolling special alloys such as Stainless Steel.

Component Parts Breakdown

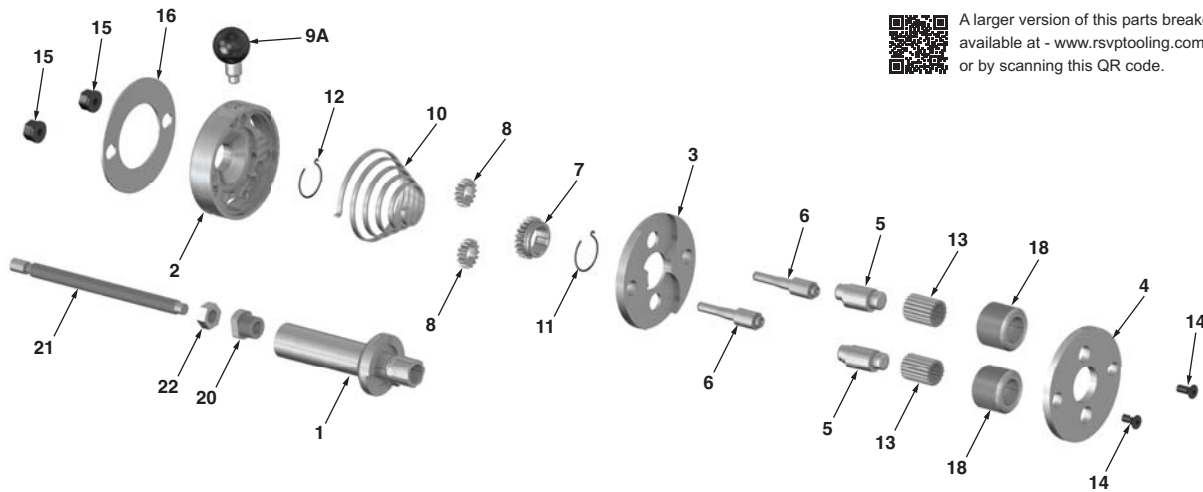

A larger version of this parts breakdown is available at - www.rsptooling.com/prints.html or by scanning this QR code.

Ref	Qty	Description	EDP
1	1	Shank	7500
2	1	Spring Housing	7501
3	1	Center Plate	7502
4	1	Front Plate	7503
5	2	Eccentric Spindle	7504
6	2	Spacer Stud	7505
7	1	Center Gear	7506
8	2	Outer Gear	7507

Ref	Qty	Description	EDP
9A	1	Handle Assy.	7508A
10	1	Coil Spring	7509
11	1	Circlip	7510
12	1	Circlip	7511
13	36	Needle Bearings	7512
13*	2	Carbide Bushing	1466
14	2	Front Plate Screw	7514
15	2	Hexagon Nut	7515

Ref	Qty	Description	EDP
16	1	Ring Washer	7516
18	3	Thread Roll (See Chart for Size & EDP)	
20	1	Stop Screw Body	7517
21	1	Stop Screw	7518
22	1	Hexagon Nut	7519

(*) #13 Needle Bearings are provided as standard. Optional Carbide Bushings provided at additional cost upon request.

A001 Axial Head

EDP	Shank	EDP	Shank
7102	3/4	7102-20	20mm
7102-5/8	5/8	7102-16	16mm

Approximate Weight: 0.1 lbs

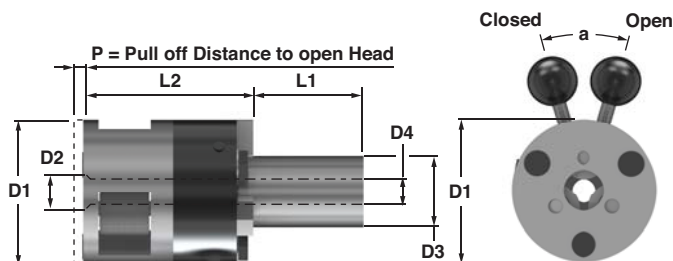

Axial Thread Rolling Heads For Right Hand Threads For Stationary Applications

A001 Axial Head Dimensions

Dimensions

		D1	D2	D3	D4
Helix Angle in Head = 4°					
Allowable Component Lead	inches	1.575	0.275	3/4 / 5/8	0.295
Angle = 2° 25' - 5° 12'	mm	40	7	20 / 16	7.5

Dimensions Continued

		L1	L2	P	a
Helix Angle in Head = 4°					
Allowable Component Lead	inches	0.985	1.575	0.060	32°
Angle = 2° 25' - 5° 12'	mm	25	40	1.5	

Left hand heads are dimensionally the same as right hand heads but open and close on the opposite direction. Thread rolls can be used in both right hand and left hand heads.

The Following Thread Rolls May Be Ordered As Standard On The A001 Axial Head

ISO Metric		
1K EDP	2K EDP	Description
8167	8168	M2.6 x 0.45
8169	8170	M3.0 x 0.5
8171	8172	M3.0 - 3.5 x 0.6
8173	8174	M4.0 x 0.7
8165	8166	M4.0 x 0.75

Unified Coarse UNC		
1K EDP	2K EDP	Description
8175	8176	No. 4 - 5 x 40
8177	8178	No. 6 - 8 x 32

Unified Fine UNF		
1K EDP	2K EDP	Description
8179	8180	No. 4 x 48
8181	8182	No. 5 x 44
8183	8184	No. 6 x 40

Threads outside of the above standard series may also be rolled on this head provided that their helix does not fall outside the permissible range.

Nitrided Rolls are available for use in rolling special alloys such as Stainless Steel.

Component Parts Breakdown

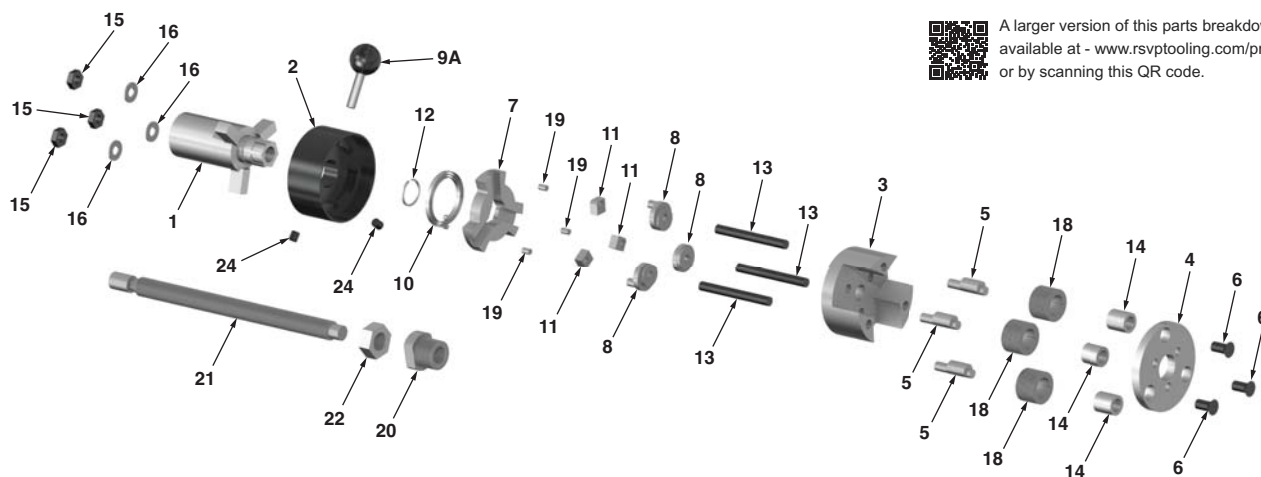

A larger version of this parts breakdown is available at - www.rsvptooling.com/prints.html or by scanning this QR code.

Ref	Qty	Description	EDP
1	1	Shank	7544
2	1	Spring Housing	7513
3	1	Center Plate	7520
4	1	Front Plate	7521
5	3	Eccentric Spindle	7522
6	3	Front Plate Screw	7523
7	1	Clutch Plate	7524
8	3	Cam	7525
9A	1	Handle Assy.	7546A

Ref	Qty	Description	EDP
10	1	Coil Spring	7545
11	3	Hardened Slide	7528
12	1	Circlip	7529
13	3	Studs	7542
14	3	Carbide Bushing	1453
15	3	Hexagon Nut	7543
16	3	Washer	7537
17	1	Hexagon Nut	7549

Ref	Qty	Description	EDP
18	3	Thread Roll (See Chart for Size & EDP)	
19	3	Shear Pin	7533
20	1	Stop Screw Body	7535
21	1	Stop Screw	7536
22	1	Hexagon Nut	7519
24	2	Set Screw	7547
25	1	Washer	7548

A01 Axial Head

EDP	Shank	EDP	Shank
7103	3/4	7103-20	20mm
7103-5/8	5/8	7103-16	16mm

Approximate Weight: 0.8 lbs

Axial Thread Rolling Heads For Right Hand Threads For Stationary Applications

A01 Axial Head Dimensions

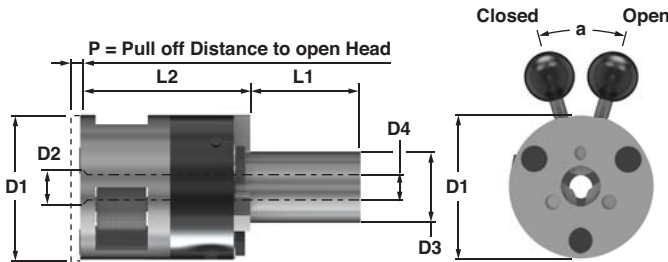

Dimensions

Helix Angle in Head = 3° 30'		D1	D2	D3	D4
Allowable Component Lead	inches	1.575	0.470	3/4 / 5/8	0.295
Angle = 2° 5' - 4° 33'	mm	40	12	20 / 16	7.5

Dimensions Continued

Helix Angle in Head = 3° 30'		L1	L2	P	a
Allowable Component Lead	inches	0.950	1.710	0.060	32°
Angle = 2° 5' - 4° 33'	mm	24	43.5	1.5	

Left hand heads are dimensionally the same as right hand heads but open and close on the opposite direction. Thread rolls can be used in both right hand and left hand heads.

The Following Thread Rolls May Be Ordered As Standard On The A01 Axial Head

ISO Metric		
1K EDP	2K EDP	Description
8189	8190	M3.5 x 0.6
8191	8192	M4.0 x 0.7
8193	8194	M4.0 - 4.5 x 0.75
8195	8196	M5.0 x 0.8
8197	8198	M5.0 - 5.5 x 0.9
8199	8200	M6.0 x 1.0

ISO Metric Fine		
1K EDP	2K EDP	Description
8201	8202	M4.0 - 5.0 x 0.5

Unified Coarse UNC		
1K EDP	2K EDP	Description
8203	8204	No. 8 x 32
8205	8206	No. 10 - 12 x 24
8217	8218	1/4 x 20

Unified Fine UNF		
1K EDP	2K EDP	Description
8207	8208	No. 6 x 40
8209	8210	No. 8 x 36
8211	8212	No. 10 x 32
8213	8214	No. 12 x 28
8215	8216	1/4 x 28

Threads outside of the above standard series may also be rolled on this head provided that their helix does not fall outside the permissible range.

Nitrided Rolls are available for use in rolling special alloys such as Stainless Steel.

Component Parts Breakdown

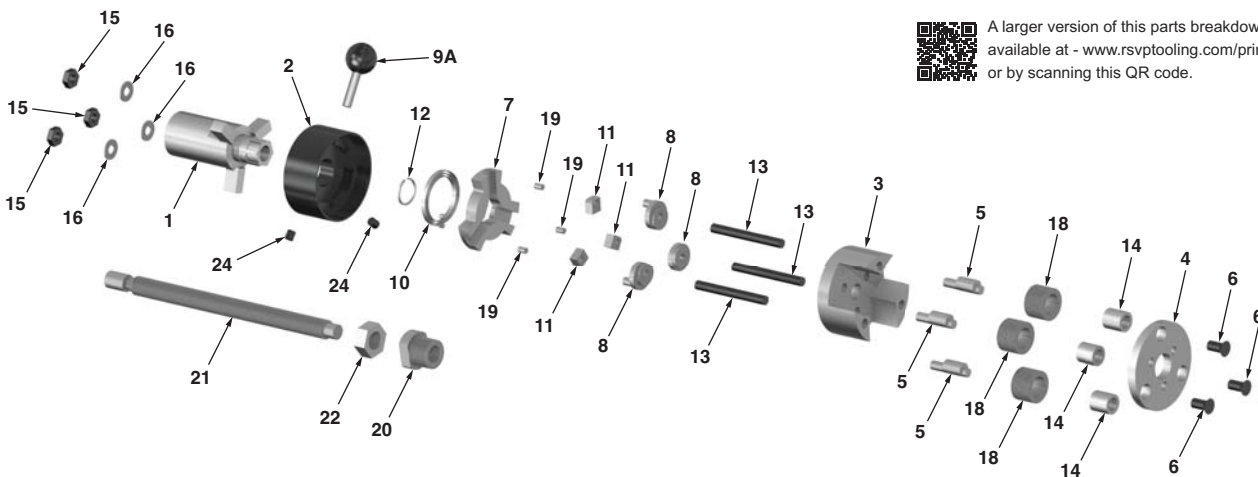

A larger version of this parts breakdown is available at www.rsvpooling.com/prints.html or by scanning this QR code.

Ref	Qty	Description	EDP
1	1	Shank	7544
2	1	Spring Housing	7686
3	1	Center Plate	7526
4	1	Front Plate	7539
5	3	Eccentric Spindle	7531
6	3	Front Plate Screw	7523
7	1	Clutch Plate	7527
8	3	Cam	7525
9A	1	Handle Assy.	7546A

Ref	Qty	Description	EDP
10	1	Coil Spring	7545
11	3	Hardened Slide	7528
12	1	Circlip	7529
13	3	Studs	7532
14	3	Carbide Bushing	1454
15	3	Hexagon Nut	7543
16	3	Washer	7537
17	1	Hexagon Nut	7549

Ref	Qty	Description	EDP
18	3	Thread Roll (See Chart for Size & EDP)	
19	3	Shear Pin	7533
20	1	Stop Screw Body	7535
21	1	Stop Screw	7536
22	1	Hexagon Nut	7519
24	2	Set Screw	7547
25	1	Washer	7548

A1 Axial Head

EDP	Shank
7104	3/4
7104-20	20mm

Approximate Weight: 2.0 lbs

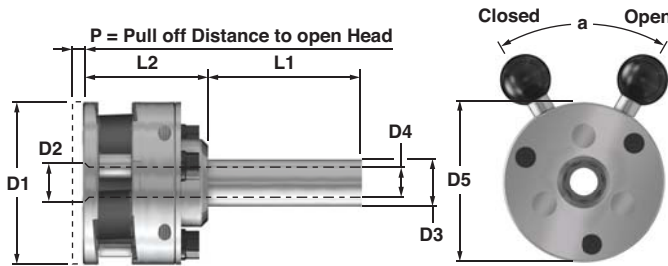

Axial Thread Rolling Heads For Right Hand Threads For Stationary Applications

A1 Axial Head Dimensions

Dimensions

	D1	D2	D3	D4	D5 max	
Helix Angle in Head = 3° 30'						
Allowable Component Lead inches	2.520	0.670	3/4	0.440	2.756	
Angle = 2° 5' - 4° 33'	mm	64	17	20	11	70

Dimensions Continued

	L1	L2	P	a
Helix Angle in Head = 3° 30'				
Allowable Component Lead inches	2.360	1.970	0.080	60°
Angle = 2° 5' - 4° 33'	mm	60	50	2

Left hand heads are dimensionally the same as right hand heads but open and close on the opposite direction. Thread rolls can be used in both right hand and left hand heads.

The Following Thread Rolls May Be Ordered As Standard On The A1 Axial Head

ISO Metric		
1K EDP	2K EDP	Description
8001	8002	M6.0 - 8.0 x 1.0
8003	8004	M8.0 - 9.0 x 1.25
8005	8006	M10.0 x 1.5

ISO Metric Fine		
1K EDP	2K EDP	Description
8047	8046	M6.0 - 8.0 x 0.75
8055	8056	M8.0 - 10.0 x 1.0
9945	9953	M10.0 - 11.0 x 1.25

Unified Coarse UNC		
1K EDP	2K EDP	Description
8007	8008	1/4 x 20
8009	8010	5/16 x 18
8011	8012	3/8 x 16
8013	8014	7/16 x 14

Unified Fine UNF		
1K EDP	2K EDP	Description
8015	8016	1/4 x 28
8017	8018	5/16 - 3/8 x 24
8068	8070	7/16 x 20

National Pipe Thread NPT		
1K EDP	2K EDP	Description
8058	8059	1/16 x 27 NPT
8060	8061	1/8 x 27 NPT

National Pipe Thread Dryseal NPTF		
1K EDP	2K EDP	Description
8062	8063	1/16 x 27 NPTF
8064	8065	1/8 x 27 NPTF

Threads outside of the above standard series may also be rolled on this head provided that their helix does not fall outside the permissible range.

Nitrided Rolls are available for use in rolling special alloys such as Stainless Steel.

Component Parts Breakdown

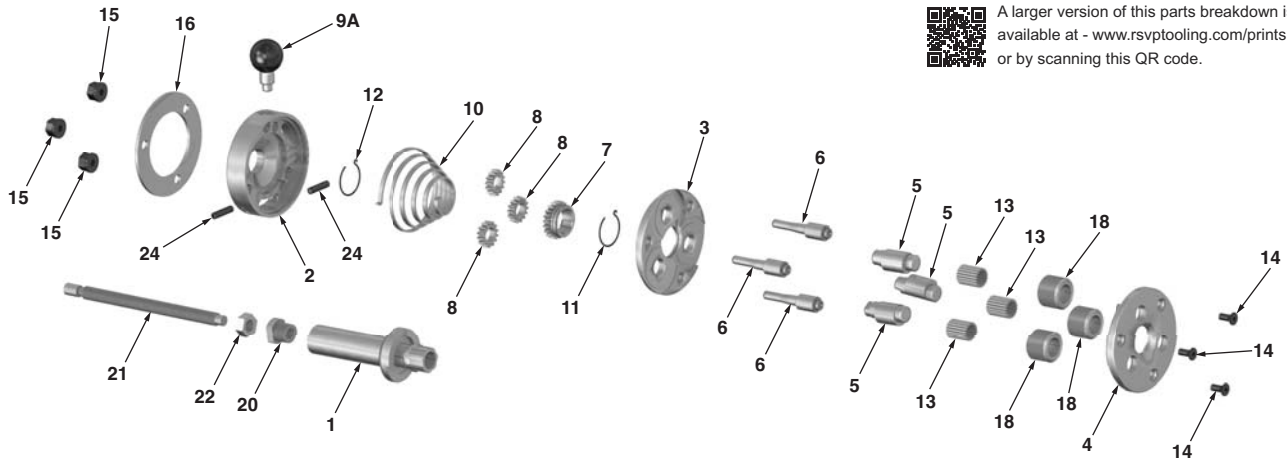

A larger version of this parts breakdown is available at - www.rsvptooling.com/prints.html or by scanning this QR code.

Ref	Qty	Description	EDP
1	1	Shank 3/4"	7554
1A	1	Shank 20mm	7554-20
2	1	Spring Housing	7571
3	1	Center Plate	7556
4	1	Front Plate	7557
5	3	Eccentric Spindle	7558
6	3	Spacer Stud	7559
7	1	Center Gear	7560

Ref	Qty	Description	EDP
8	3	Outer Gear	7561
9A	1	Handle Assy.	7576A
10	1	Coil Spring	7563
11	1	Circlip	7564
12	1	Circlip	7565
13	57	Needle Roller Bearings	7566
13*	3	Carbide Bushing	1455
14	3	Front Plate Screw	7568

Ref	Qty	Description	EDP
15	3	Hexagon Nut	7578
16	1	Ring Washer	7570
18	3	Thread Roll (See Chart for Size & EDP)	
20	1	Stop Screw Body	2185
21	1	Stop Screw	2187
22	1	Hexagon Nut	2186
24	2	Set Screw (2/set)	2190

(*) #13 Needle Bearings are provided as standard. Optional Carbide Bushings provided at additional cost upon request.

A12 Axial Head

EDP	Shank
7105	3/4
7105-20	20mm

Approximate Weight: 2.0 lbs

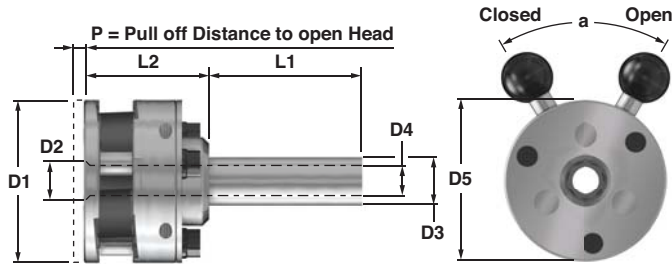

Axial Thread Rolling Heads For Right Hand Threads For Stationary Applications

A12 Axial Head Dimensions

Dimensions

Helix Angle in Head = 1° 50'	D1	D2	D3	D4	D5 max	
Allowable Component Lead inches	2.520	0.790	3/4	0.430	2.756	
Angle = 1° 5' - 2° 23'	mm	64	20	20	11	70

Dimensions Continued

Helix Angle in Head = 1° 50'	L1	L2	P	a
Allowable Component Lead inches	2.360	1.970	0.080	60°
Angle = 1° 5' - 2° 23'	mm	60	50	2

Left hand heads are dimensionally the same as right hand heads but open and close on the opposite direction. Thread rolls can be used in both right hand and left hand heads.

The Following Thread Rolls May Be Ordered As Standard On The A12 Axial Head

ISO Metric Fine		
1K EDP	2K EDP	Description
8229	8230	M6.0 - 7.0 x 0.5
8231	8232	M7.0 - 8.0 x 0.5
8233	8234	M6.0 x 7.0 x 0.75
8235	8236	M8.0 - 9.0 x 0.75
8237	8238	M9.0 - 10.0 x 0.75
8239	8240	M10.0 - 11.0 x 0.75*
8241	8242	M11.0 - 12.0 x 0.75*
8243	8244	M8.0 - 9.0 x 1.0
8245	8246	M9.0 - 10.0 x 1.0
8247	8248	M10.0 - 11.0 x 1.0
8249	8250	M11.0 - 12.0 x 1.0

ISO Metric Fine (Continued)		
1K EDP	2K EDP	Description
8251	8252	M10 - 11.0 x 1.25
8253	8254	M11.0 - 12.0 x 1.25
8255	8256	M12.0 x 1.5

Unified Fine UNF		
1K EDP	2K EDP	Description
8257	8258	1/4 - 5/16 x 40
8259	8260	5/16 - 3/8 x 36
8261	8262	7/16 x 36*
8263	8264	5/16 - 3/8 x 32
8265	8266	7/16 - 1/2 x 32*

Unified Fine UNF (Continued)		
1K EDP	2K EDP	Description
8267	8268	3/8 - 7/16 x 28*
8269	8270	1/2 x 28*
8271	8272	7/16 - 1/2 x 26*
8273	8274	3/8 - 7/16 x 24*
8275	8276	7/16 - 1/2 x 24*
8277	8278	7/16 - 1/2 x 22*
8279	8280	7/16 - 1/2 x 20*

National Pipe Thread NPT		
1K EDP	2K EDP	Description
8281	8282	1/8 x 27 NPT
8283	8284	1/4 x 18 NPT

National Pipe Thread Dryseal NPTF		
1K EDP	2K EDP	Description
8285	8286	1/8 x 27 NPTF
8287	8288	1/4 x 18 NPTF

(*) Limited to short threads up to 14mm (0.551") including thread runout

Threads outside of the above standard series may also be rolled on this head provided that their helix does not fall outside the permissible range.

Nitrided Rolls are available for use in rolling special alloys such as Stainless Steel.

Component Parts Breakdown

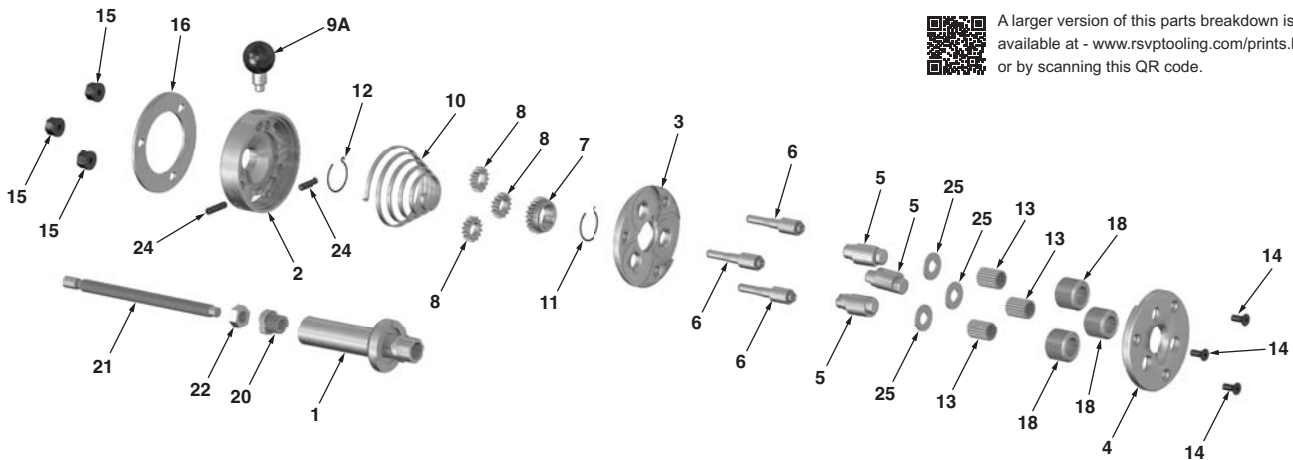

A larger version of this parts breakdown is available at www.rsptooling.com/prints.html or by scanning this QR code.

Ref	Qty	Description	EDP
1	1	Shank 3/4"	7554
1A	1	Shank 20mm	7554-20
2	1	Spring Housing	7571
3	1	Center Plate	7610
4	1	Front Plate	7581
5	3	Eccentric Spindle	7580
6	3	Spacer Stud	7654
7	1	Center Gear	2177
8	3	Outer Gear	7579

Ref	Qty	Description	EDP
9A	1	Handle Assy.	7576A
10	1	Coil Spring	7563
11	1	Circlip	7564
12	1	Circlip	7565
13	57	Needle Roller Bearings	7584
13*	3	Carbide Bushing	1467
14	3	Front Plate Screw	7568
15	3	Hexagon Nut	7578

Ref	Qty	Description	EDP
16	1	Ring Washer	7570
18	3	Thread Roll (See Chart for Size & EDP)	
20	1	Stop Screw Body	2185
21	1	Stop Screw	2187
22	1	Hexagon Nut	2186
24	2	Set Screw (2/set)	2190
25	3	Washer	7585

(*) #13 Needle Bearings are provided as standard. Optional Carbide Bushings provided at additional cost upon request.

A2 Axial Head

EDP	Shank
7106	1"
7106-25	25mm

Approximate Weight: 4.2 lbs

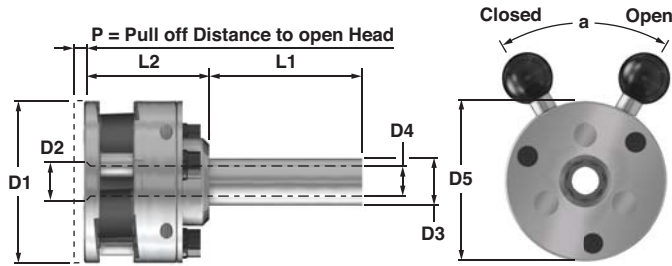

Axial Thread Rolling Heads For Right Hand Threads For Stationary Applications

A2 Axial Head Dimensions

Dimensions

		D1	D2	D3	D4	D5 max
Helix Angle in Head = 3°						
Allowable Component Lead	inches	3.460	0.940	1	0.670	3.681
Angle = 1° 50' - 4° 15'	mm	88	24	25	17	93.5

Dimensions Continued

		L1	L2	P	a
Helix Angle in Head = 3°					
Allowable Component Lead	inches	2.990	2.720	0.120	60°
Angle = 1° 50' - 4° 15'	mm	76	69	3	

Left hand heads are dimensionally the same as right hand heads but open and close on the opposite direction. Thread rolls can be used in both right hand and left hand heads.

The Following Thread Rolls May Be Ordered As Standard On The A2 Axial Head

ISO Metric		
1K EDP	2K EDP	Description
8019	8020	M8.0 - 10.0 x 1.25
8021	8022	M10.0 - 12.0 x 1.5
8023	8024	M12.0 - 14.0 x 1.75
8025	8026	M14.0 - 16.0 x 2.0

ISO Metric Fine		
1K EDP	2K EDP	Description
8073	8074	M8.0 - 10.0 x 1.0
8075	8076	M10.0 - 12.0 x 1.25
8077	8078	M12.0 - 14.0 x 1.5

Unified Coarse UNC		
1K EDP	2K EDP	Description
8027	8028	5/16 x 18
8029	8030	3/8 x 16
8031	8032	7/16 x 14
8033	8034	1/2 x 13
8035	8036	9/16 x 12
8037	8038	5/8 x 11

Unified Fine UNF		
1K EDP	2K EDP	Description
8039	8040	5/16 - 3/8 x 24
8041	8042	7/16 - 1/2 x 20
8043	8044	9/16 - 5/8 x 18

National Pipe Thread NPT		
1K EDP	2K EDP	Description
8084	8085	1/4 x 18 NPT

National Pipe Thread Dryseal NPTF		
1K EDP	2K EDP	Description
8086	8087	1/4 x 18 NPTF

Threads outside of the above standard series may also be rolled on this head provided that their helix does not fall outside the permissible range.

Nitrided Rolls are available for use in rolling special alloys such as Stainless Steel.

Component Parts Breakdown

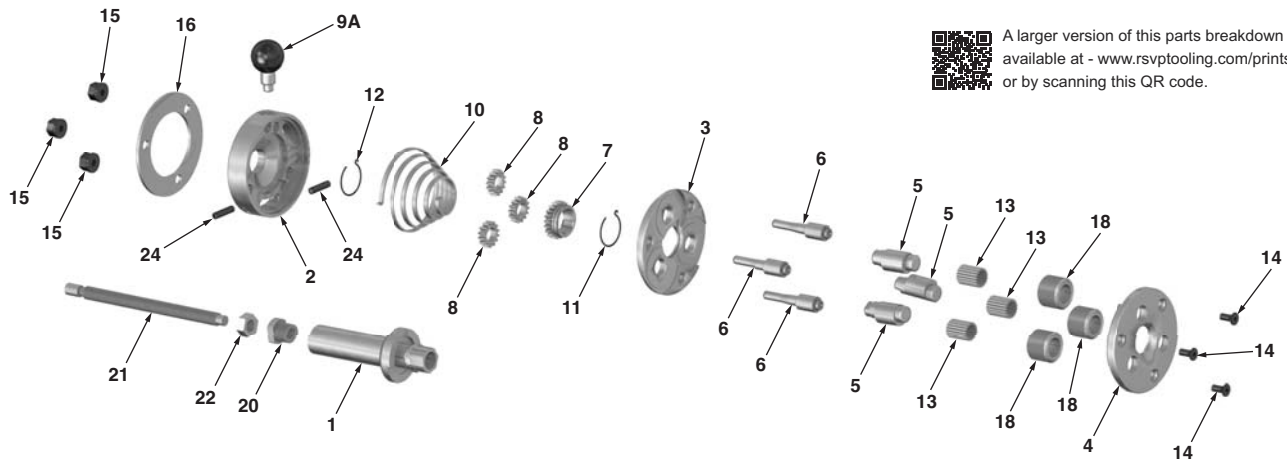

A larger version of this parts breakdown is available at - www.rsvp tooling.com/prints.html or by scanning this QR code.

Ref	Qty	Description	EDP
1	1	Shank 1"	7590
1A	1	Shank 25mm	7590-25
2	1	Spring Housing	7310
3	1	Center Plate	7593
4	1	Front Plate	7594
5	3	Eccentric Spindle	7595
6	3	Spacer Stud	7609
7	1	Center Gear	7597

Ref	Qty	Description	EDP
8	3	Outer Gear	7598
9A	1	Handle Assy.	7604A
10	1	Coil Spring	7600
11	1	Circlip	7601
12	1	Circlip	7683
13	57	Needle Roller Bearings	7603
13*	3	Carbide Bushing	1461
14	3	Front Plate Screw	7605

Ref	Qty	Description	EDP
15	3	Hexagon Nut	7606
16	1	Ring Washer	7596
18	3	Thread Roll (See Chart for Size & EDP)	
20	1	Stop Screw Body	7592
21	1	Stop Screw	7599
22	1	Hexagon Nut	7602
24	2	Set Screw (2/set)	7311

(*) #13 Needle Bearings are provided as standard. Optional Carbide Bushings provided at additional cost upon request.

A23 Axial Head

EDP	Shank
7107	1"
7107-25	25mm

Approximate Weight: 4.2 lbs

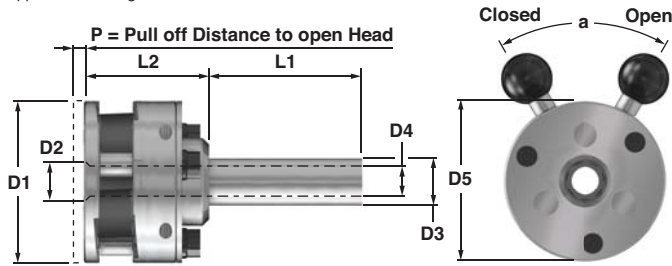

Axial Thread Rolling Heads For Right Hand Threads For Stationary Applications

A23 Axial Head Dimensions

Dimensions

Helix Angle in Head = 1° 25'	D1	D2	D3	D4	D5 max	
Allowable Component Lead	inches	3.470	1.100	1	0.670	3.681
Angle = 0° 50' - 2° 0'	mm	88	28	25	17	93.5

Dimensions Continued

Helix Angle in Head = 1° 25'	L1	L2	P	a	
Allowable Component Lead	inches	2.990	2.720	0.120	60°
Angle = 0° 50' - 2° 0'	mm	76	69	3	

Left hand heads are dimensionally the same as right hand heads but open and close on the opposite direction. Thread rolls can be used in both right hand and left hand heads.

The Following Thread Rolls May Be Ordered As Standard On The A23 Axial Head

ISO Metric Fine		
1K EDP	2K EDP	Description
8323	8324	M8.0 - 10.0 x 0.5
8325	8326	M8.0 - 10.0 x 0.75
8289	8290	M10.0 - 12.0 x 0.75
8291	8292	M10.0 - 12.0 x 1.0
8293	8294	M12.0 - 14.0 x 1.0
8341	8342	M14.0 - 16.0 x 1.0
8297	8298	M16.0 - 18.0 x 1.0
8299	8300	M18.0 - 20.0 x 1.0
8301	8302	M14.0 - 16.0 x 1.25
8303	8304*	M16.0 - 18.0 x 1.5
8305	8306*	M18.0 - 20.0 x 1.5
8307	8308*	M20.0 - 22.0 x 1.5

Unified Fine UNF		
1K EDP	2K EDP	Description
8327	8328	5/16 - 3/8 x 32
8329	8330	3/8 - 7/16 x 32
8331	8332	7/16 - 1/2 x 28
8333	8334	7/16 - 1/2 x 32
8353	8354	1/2 - 9/16 x 20
8337	8338	1/2 - 9/16 x 28
8339	8340	1/2 - 9/16 x 32
8365	8366	9/16 - 5/8 x 18
8343	8344	9/16 - 5/8 x 20
8345	8346	9/16 - 5/8 x 24
8347	8348	9/16 - 5/8 x 28
8335	8336	9/16 - 5/8 x 32

Unified Fine UNF (Continued)		
1K EDP	2K EDP	Description
8351	8352	5/8 - 11/16 x 16*
8349	8350	5/8 - 11/16 x 20*
8367	8368	5/8 - 11/16 x 24*
8369	8370	5/8 - 11/16 x 28*
8359	8360	11/16 - 3/4 x 16*
8361	8362	11/16 - 3/4 x 20*
8363	8364	3/4 - 13/16 x 16*
8365	8366	3/4 - 13/16 x 20*
8355	8356	13/16 - 7/8 x 20*

National Pipe Thread NPT		
1K EDP	2K EDP	Description
8309	8310	1/8 x 27 NPT
8313	8314	1/4 x 18 NPT
8315	8316	3/8 x 18 NPT

National Pipe Thread Dryseal NPTF		
1K EDP	2K EDP	Description
8317	8318	1/8 x 27 NPTF
8319	8320	1/4 x 18 NPTF
8321	8322	3/8 x 18 NPTF

(*) Limited to short threads up to 19mm (0.748") including thread runout

Threads outside of the above standard series may also be rolled on this head provided that their helix does not fall outside the permissible range.

Nitrided Rolls are available for use in rolling special alloys such as Stainless Steel.

Component Parts Breakdown

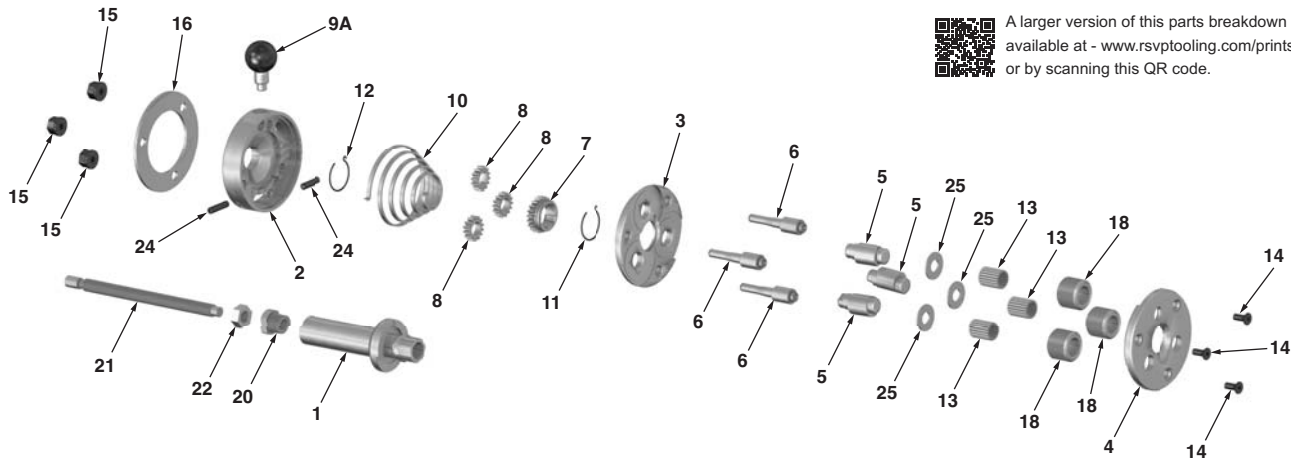

A larger version of this parts breakdown is available at - www.rsvp tooling.com/prints.html or by scanning this QR code.



Ref	Qty	Description	EDP
1	1	Shank 1"	7590
1A	1	Shank 25mm	7590-25
2	1	Spring Housing	7310
3	1	Center Plate	7491
4	1	Front Plate	7492
5	3	Eccentric Spindle	7589
6	3	Spacer Stud	7493
7	1	Center Gear	7494

Ref	Qty	Description	EDP
8	3	Outer Gear	7495
9A	1	Handle Assy.	7604A
10	1	Coil Spring	7600
11	1	Circlip	7601
12	1	Circlip	7683
13	57	Needle Roller Bearings	7566
13*	3	Carbide Bushing	1455
14	3	Front Plate Screw	7605

Ref	Qty	Description	EDP
15	3	Hexagon Nut	7606
16	1	Ring Washer	7596
18	3	Thread Roll (See Chart for Size & EDP)	
20	1	Stop Screw Body	7592
21	1	Stop Screw	7599
22	1	Hexagon Nut	7602
24	2	Set Screw (2/set)	7311
25	3	Washer	7673

(*) #13 Needle Bearings are provided as standard. Optional Carbide Bushings provided at additional cost upon request.

A233400 Axial Head

Axial Thread Rolling Heads
For Right Hand Threads
For Stationary Applications

EDP	Shank	EDP	Shank
7108	1"	7108-30	30mm
7108-1.25	1-1/4"	7108-25	25mm

Approximate Weight: 6.4 lbs

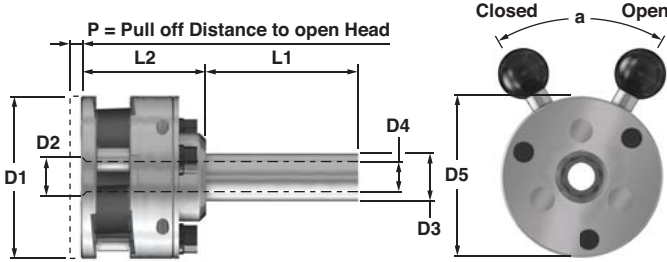

Dimensions

	D1	D2	D3	D4	D5 max
Helix Angle in Head = 1° 15'					
Allowable Component Lead inches	3.780	1.540	1 / 1.1/4	0.550	4.528
Angle = 0° 45' - 1° 40'	mm	96	39	25 / 30	14

Dimensions Continued

	L1	L2	P	a
Helix Angle in Head = 1° 15'				
Allowable Component Lead inches	2.360	3.250	0.120	30°
Angle = 0° 45' - 1° 40'	mm	115	60	82.5

Left hand heads are dimensionally the same as right hand heads but open and close on the opposite direction. Thread rolls can be used in both right hand and left hand heads.

The Following Thread Rolls May Be Ordered As Standard On The A233400 Axial Head

ISO Metric Fine		
1K EDP	2K EDP	Description
8373	8374	M16.0 - 18.0 x 1.5
8375	8376	M18.0 - 20.0 x 1.5
8377	8378	M20.0 - 22.0 x 1.5
8379	8380	M22.0 - 24.0 x 1.5
8381	8382	M24.0 - 26.0 x 1.5
8383	8384	M26.0 - 28.0 x 1.5
8385	8386	M28.0 - 30.0 x 1.5
8387	8388	M30.0 - 32.0 x 1.5
8389	8390	M32.0 - 34.0 x 1.5
8391	8392	M34.0 - 36.0 x 1.5
8393	8394	M22.0 - 24.0 x 2.0
8395	8396	M24.0 - 26.0 x 2.0
8397	8398	M26.0 - 28.0 x 2.0
8399	8400	M28.0 - 30.0 x 2.0
8401	8402	M30.0 - 32.0 x 2.0
8403	8404	M32.0 - 34.0 x 2.0
8405	8406	M34.0 - 36.0 x 2.0

Unified Fine UNF		
1K EDP	2K EDP	Description
8419	8420	3/4 x 26*
8421	8422	5/8 x 24*
8423	8424	11/16 x 24*
8425	8426	3/4 x 24*
8427	8428	7/8 x 24*
8429	8430	3/4 x 22*
8431	8432	7/8 x 22*
8433	8434	5/8 - 11/16 x 20*
8435	8436	11/16 - 3/4 x 20*
8437	8438	3/4 - 13/16 x 20*
8439	8440	13/16 - 7/8 x 20*
8441	8442	7/8 - 15/16 x 20*
8443	8444	15/16 - 1 x 20*
8445	8446	1 - 1-1/16 x 20*
8447	8448	1-1/16* - 1-1/8** x 20
8449	8450	1-1/8** - 1-3/16** x 20
8451	8452	5/8 x 18*
8453	8454	3/4 x 18*
8455	8456	7/8 x 18*
8457	8458	1" - 1-1/16 x 18*
8459	8460	1-1/16* - 1-1/8** x 18

Unified Fine UNF (Continued)		
1K EDP	2K EDP	Description
8461	8462	1-1/8 - 1-3/16 x 18**
8463	8464	11/16 - 3/4 x 16*
8465	8466	13/16 - 7/8 x 16*
8467	8468	7/8 - 15/16 x 16*
8469	8470	15/16 - 1 x 16*
8471	8472	1" - 1-1/16 x 16**
8473	8474	1-1/16* - 1-1/8** x 16
8475	8476	1-1/8 - 1-3/16 x 16**
8477	8478	1-3/16 - 1-1/4 x 16**
8479	8480	1-1/4 - 1-5/16 x 16**
8481	8482	1-5/16 - 1-3/8 16**
8483	8484	1-3/8 - 1-7/16 x 16**
8485	8486	13/16 - 7/8 x 14*
8487	8488	7/8 - 15/16 x 14*
8489	8490	15/16 - 1 x 14*
8491	8492	1" - 1-1/16 x 14**
8493	8494	1-1/16* - 1-1/8** x 14
8495	8496	1-1/8 - 1-3/16 x 14**
8497	8498	1-3/16 - 1-1/4 x 14**
8499	8500	1-1/4 - 1-5/16 x 14**
8501	8502	1-5/16 - 1-3/8 14**

Unified Fine UNF (Continued)		
1K EDP	2K EDP	Description
8503	8504	1-3/8 - 1-7/16 x 14**
8505	8506	7/8 - 15/16 x 12*
8507	8508	15/16 - 1 x 12*
8509	8510	1" - 1-1/16 x 12**
8511	8512	1-1/16* - 1-1/8** x 12
8513	8514	1-1/8 - 1-3/16 x 12**
8515	8516	1-3/16 - 1-1/4 x 12**
8517	8518	1-1/4 - 1-5/16 x 12**
8519	8520	1-5/16 - 1-3/8 x 12**
8521	8522	1-3/8 - 1-7/16 x 12**

National Pipe Thread NPT

1K EDP	2K EDP	Description
8407	8408	3/8 x 18 NPT

National Pipe Thread Dryseal NPTF

1K EDP	2K EDP	Description
8409	8410	3/8 x 18 NPTF

(*) Limited to short threads up to 67mm (2.638") including thread runout
(**) Limited to short threads up to 24mm (1.063") including thread runout

Component Parts Breakdown

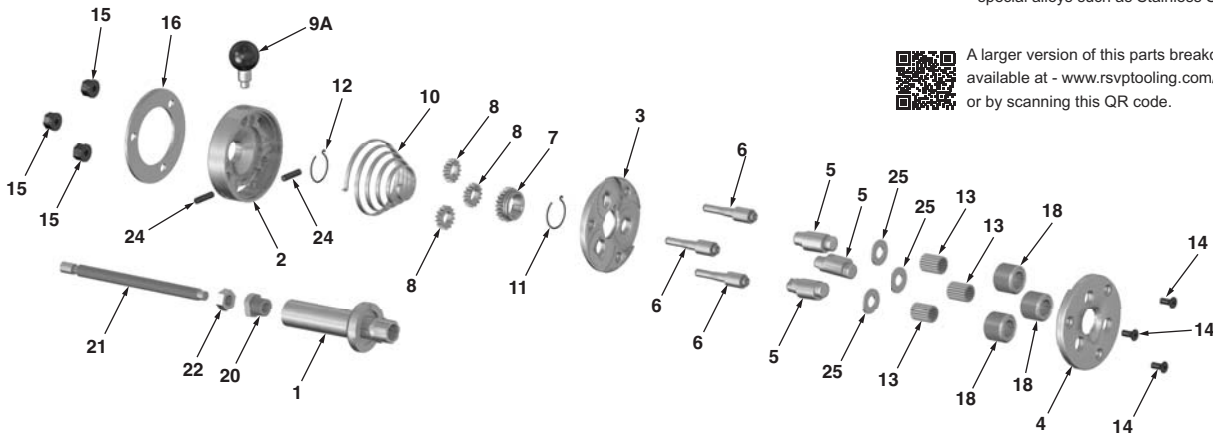

A larger version of this parts breakdown is available at www.rsviewportooling.com/prints.html or by scanning this QR code.

Ref	Qty	Description	EDP
1	1	Shank 1-1/4	7389
1A	1	Shank 1"	7389-1
1B	1	Shank 30mm	7389-30
1C	1	Shank 25mm	7389-25
2	1	Spring Housing	7339
3	1	Center Plate	7340
4	1	Front Plate	7341
5	3	Eccentric Spindle	7388
6	3	Spacer Stud	7342

Ref	Qty	Description	EDP
7	1	Center Gear	7344
8	3	Outer Gear	7345
9A	1	Handle Assy.	7346A
10	1	Coil Spring	7347
11	1	Circlip	7348
12	1	Circlip	7349
13	57	Needle Roller Bearings	7350
13*	3	Carbide Bushing	1458
14	3	Front Plate Screw	7351

Ref	Qty	Description	EDP
15	3	Hexagon Nut	7352
16	1	Ring Washer	7353
18	3	Thread Roll	(See Chart for Size & EDP)
20	1	Stop Screw Body	7592
21	1	Stop Screw	7599
22	1	Hexagon Nut	7602
24	2	Set Screw (2/set)	7354
25	3	Washer	7355

(*) #13 Needle Bearings are provided as standard. Optional Carbide Bushings provided at additional cost upon request.

A3 Axial Head

EDP	Shank	EDP	Shank
7109	1-1/2	7109-30	30mm
7109-1.25	1-1/4	7109-32	32mm

Approximate Weight: 8.3 lbs

Axial Thread Rolling Heads For Right Hand Threads For Stationary Applications

A3 Axial Head Dimensions

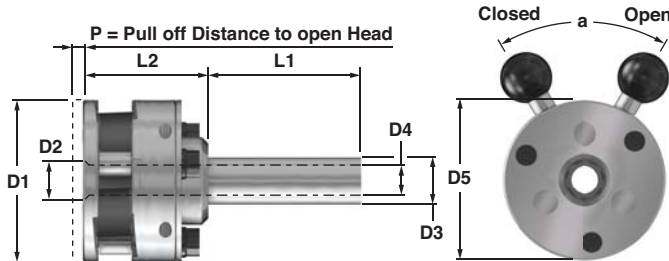

Dimensions

	D1	D2	D3	D4	D5 max
Helix Angle in Head = 2° 40'					
Allowable Component Lead inches	4.600	1.500	1.25/1.5	0.870	5.157
Angle = 1° 35' - 3° 30'	mm	117	38	30 / 40	22

Dimensions Continued

	L1	L2	P	a
Helix Angle in Head = 2° 40'				
Allowable Component Lead inches	3.540	3.270	0.160	60°
Angle = 1° 35' - 3° 30'	mm	89	83	4

Left hand heads are dimensionally the same as right hand heads but open and close on the opposite direction. Thread rolls can be used in both right hand and left hand heads.

The Following Thread Rolls May Be Ordered As Standard On The A3 Axial Head

ISO Metric		
1K EDP	2K EDP	Description
8523	8562	M12.0 - 14.0 x 1.75
8525	8526	M14.0 - 16.0 x 2.0
8527	8528	M18.0 - 20.0 x 2.5
8529	8530	M20.0 - 22.0 x 2.5

Unified Coarse UNC		
1K EDP	2K EDP	Description
8539	8540	7/16 x 14
8541	8542	1/2 x 13
8543	8563	9/16 x 12
8545	8546	5/8 x 11
8547	8548	3/4 x 10
8549	8550	7/8 x 9

Unified Fine UNF		
1K EDP	2K EDP	Description
8551	8552	7/16 - 1/2 x 20
8553	8554	9/16 - 5/8 x 18
1514	1492	3/4 x 16
8561	8560	7/8 x 14

National Pipe Thread NPT		
1K EDP	2K EDP	Description
8569	8570	1/4 x 18 NPT

ISO Metric Fine		
1K EDP	2K EDP	Description
8531	8532	M12.0 - 14.0 x 1.5
8533	8534	M14.0 - 16.0 x 1.5
8535	8536	M18.0 - 20.0 x 2.0
8537	8538	M20.0 - 22.0 x 2.0

Threads outside of the above standard series may also be rolled on this head provided that their helix does not fall outside the permissible range.

Nitrided Rolls are available for use in rolling special alloys such as Stainless Steel.

National Pipe Thread Dryseal NPTF		
1K EDP	2K EDP	Description
8567	8568	1/4 x 18 NPTF

Component Parts Breakdown

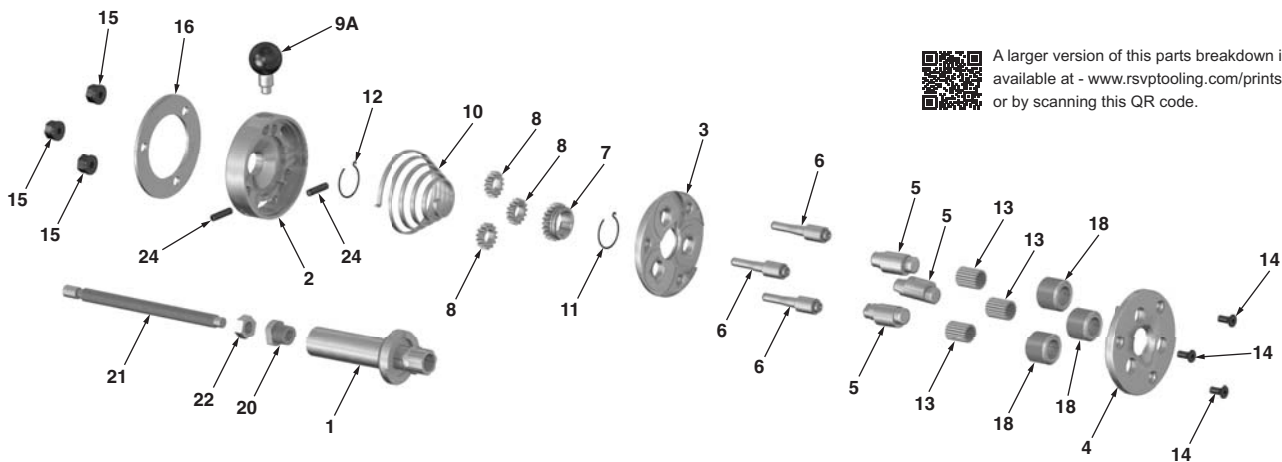

A larger version of this parts breakdown is available at - www.rsvptooling.com/prints.html or by scanning this QR code.

Ref	Qty	Description	EDP
1	1	Shank 1-1/2	7364
1A	1	Shank 1-1/4	7361
1B	1	Shank 30mm	7364-30
1C	1	Shank 32mm	7364-32
2	1	Spring Housing	7375
3	1	Center Plate	7358
4	1	Front Plate	7359
5	3	Eccentric Spindle	7360
6	3	Spacer Stud	7357

Ref	Qty	Description	EDP
7	1	Center Gear	7362
8	3	Outer Gear	7363
9A	1	Handle Assy.	7369A
10	1	Coil Spring	7365
11	1	Circlip	7366
12	1	Circlip	7367
13	57	Needle Roller Bearings	7368
13*	3	Carbide Bushing	1460
14	3	Front Plate Screw	7370

Ref	Qty	Description	EDP
15	3	Hexagon Nut	7371
16	1	Ring Washer	7387
18	3	Thread Roll (See Chart for Size & EDP)	
20	1	Stop Screw Body	7372
21	1	Stop Screw	7373
22	1	Hexagon Nut	7374
24	2	Set Screw (2/set)	7312

(*) #13 Needle Bearings are provided as standard. Optional Carbide Bushings provided at additional cost upon request.

A34 Axial Head

Axial Thread Rolling Heads
For Right Hand Threads
For Stationary Applications

EDP	Shank	EDP	Shank
7110	1-1/2	7110-30	30mm
7110-1-1/4	1-1/4	7110-32	32mm

Approximate Weight: 8.3 lbs

A34 Axial Head Dimensions

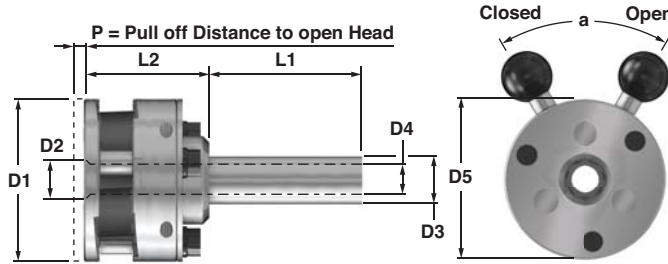

Dimensions

	D1	D2	D3	D4	D5 max
Helix Angle in Head = 1° 15'					
Allowable Component Lead inches	4.610	1.730	1.25/1.5	0.870	5.039
Angle = 0° 45' - 1° 40'	mm	117	44	30 / 40	22

Dimensions Continued

	L1	L2	P	a
Helix Angle in Head = 1° 15'				
Allowable Component Lead inches	3.540	3.290	0.160	60°
Angle = 0° 45' - 1° 40'	mm	89	83.5	4

Left hand heads are dimensionally the same as right hand heads but open and close on the opposite direction. Thread rolls can be used in both right hand and left hand heads.

The Following Thread Rolls May Be Ordered As Standard On The A34 Axial Head

ISO Metric Fine		
1K EDP	2K EDP	Description
8579	8580	M12.0 - 14.0 x 1.0
8581	8582	M14.0 - 16.0 x 1.0
8583	8584	M16.0 - 18.0 x 1.0
8596	8586	M18.0 - 20.0 x 1.0
8587	8588	M16.0 - 18.0 x 1.5
8589	8590	M18.0 - 20.0 x 1.5
8591	8600	M20.0 - 22.0 x 1.5
8601	8602	M22.0 - 24.0 x 1.5*
8603	8604	M24.0 - 27.0 x 1.5*
8605	8606	M27.0 - 30.0 x 1.5*

Unified Fine UNF		
1K EDP	2K EDP	Description
8607	8608	1/2 x 28
8609	8610	5/8 - 11/16 x 28
8611	8612	11/16 - 3/4 x 28
8613	8614	3/4 - 13/16 x 28
8615	8616	13/16 - 7/8* x 28
8617	8618	9/16 - 5/8 x 24
8619	8620	5/8 - 11/16 x 24
8623	8624	5/8 - 11/16 x 20
8625	8626	3/4 - 13/16 x 20
8631	8632	13/16 - 7/8* x 20

Unified Fine UNF (Continued)		
1K EDP	2K EDP	Description
8633	8634	7/8 - 15/16 x 20*
8635	8636	15/16 - 1" x 20*
8627	8628	5/8 x 18
8637	8638	1-1/16 - 1-1/8 x 18*
8639	8640	3/4 - 13/16 x 16
8641	8642	7/8 - 15/16 x 16*
8645	8648	7/8 x 14
8643	8644	7/8 - 15/16 x 12*
8651	8652	1" x 12*
8647	8649	1" x 14**

National Pipe Thread NPT		
1K EDP	2K EDP	Description
8571	8572	3/8 x 18 NPT
8573	8574	1/2 x 14 NPT
8575	8576	3/4 x 14 NPT

National Pipe Thread Dryseal NPTF		
1K EDP	2K EDP	Description
8577	8578	3/8 x 18 NPTF
8653	8654	1/2 x 14 NPTF
8655	8656	3/4 x 14 NPTF

(* Limited to short threads up to 24mm (0.945") including thread runoff

Threads outside of the above standard series may also be rolled on this head provided that their helix does not fall outside the permissible range.

Nitrided Rolls are available for use in rolling special alloys such as Stainless Steel.

Component Parts Breakdown

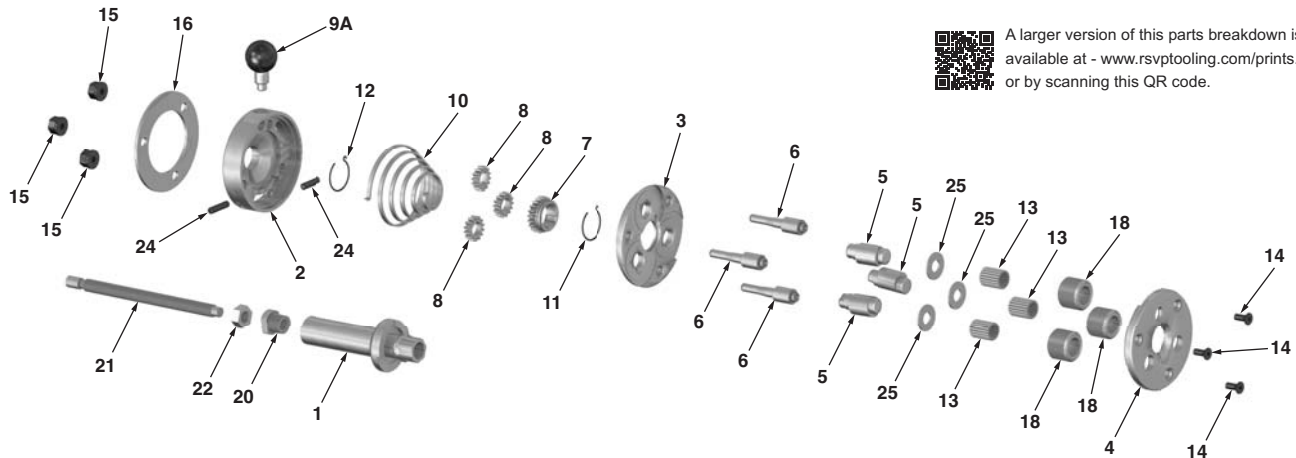

A larger version of this parts breakdown is available at - www.rsvp tooling.com/prints.html or by scanning this QR code.

Ref	Qty	Description	EDP
1	1	Shank 1-1/2	7364
1A	1	Shank 1-1/4	7361
1B	1	Shank 30mm	7364-30
1C	1	Shank 32mm	7364-32
2	1	Spring Housing	7375
3	1	Center Plate	7396
4	1	Front Plate	7397
5	3	Eccentric Spindle	7394
6	3	Spacer Stud	7680

Ref	Qty	Description	EDP
7	1	Center Gear	7393
8	3	Outer Gear	7395
9A	1	Handle Assy.	7369A
10	1	Coil Spring	7365
11	1	Circlip	7398
12	1	Circlip	7367
13	57	Needle Roller Bearings	7603
13*	3	Carbide Bushing	1461
14	3	Front Plate Screw	7370

Ref	Qty	Description	EDP
15	3	Hexagon Nut	7371
16	1	Ring Washer	7387
18	3	Thread Roll	(See Chart for Size & EDP)
20	1	Stop Screw Body	7372
21	1	Stop Screw	7373
22	1	Hexagon Nut	7374
24	2	Set Screw (2/set)	7312
25	3	Washer	7395

(* #13 Needle Bearings are provided as standard. Optional Carbide Bushings provided at additional cost upon request.

A4 Axial Head

EDP	Shank	EDP	Shank
7121	1/1/02	7121-40	40mm
7124	2"	7124-50	50mm

Approximate Weight: 30 lbs

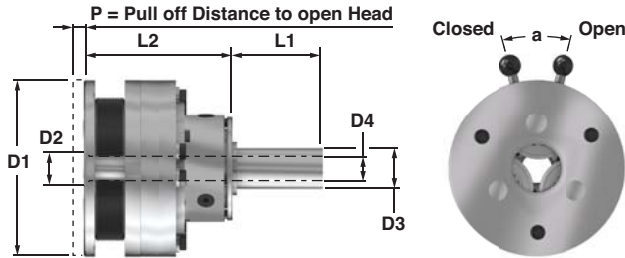

Axial Thread Rolling Heads For Right Hand Threads For Stationary Applications

A4 Axial Head Dimensions

Dimensions

	D1	D2	D3	D4
Helix Angle in Head = 2° 30'				
Allowable Component Lead	inches	6.339	1.811	1.5 / 2 1.100 / 1.260
Angle = 1° 30' - 3° 10'	mm	161	46	40 / 50 28 / 32

Dimensions Continued

	L1	L2	P	a
Helix Angle in Head = 2° 30'				
Allowable Component Lead	inches	2.953	6.142	0.157 30°
Angle = 1° 30' - 3° 10'	mm	75	156	4

Left hand heads are dimensionally the same as right hand heads but open and close on the opposite direction. Thread rolls can be used in both right hand and left hand heads.

The Following Thread Rolls May Be Ordered As Standard ON The A4 Axial Head

ISO Metric		
1K EDP	2K EDP	Description
8745	8746	M14.0 - 16.0 x 2.0
8747	8748	M18.0 - 20.0 x 2.5
8592	8750	M20.0 - 22.0 x 2.5
8749	8690	M24.0 - 27.0 x 3.0
2826	2827	M27.0 - 30.0 x 3.5

Unified Coarse UNC		
1K EDP	2K EDP	Description
8759	8760	9/16 x 12
8696	8697	5/8 x 11
2514	2523	3/4 x 10
8699	2850	7/8 x 9
1742	1638	1" x 8
8761	8762	1-1/8 x 7

Unified Fine UNF		
1K EDP	2K EDP	Description
2181	8763	9/16 - 5/8 x 18
8693	8764	3/4 x 16
2496	8765	7/8 x 14
2547	2548	1 x 12
8597	8599	1 x 14

National Pipe Thread NPT		
1K EDP	2K EDP	Description
8766	8767	1/2 x 14 NPT

National Pipe Thread Dryseal NPTF		
1K EDP	2K EDP	Description
8768	8769	1/2 x 14 NPTF

ISO Metric Fine		
1K EDP	2K EDP	Description
8751	8752	M14.0 - 16.0 x 1.5
8753	8754	M16.0 - 18.0 x 1.5
8755	8756	M18.0 - 20.0 x 2.0
8757	8758	M22.0 - 24.0 x 2.0

Threads outside of the above standard series may also be rolled on this head provided that their helix does not fall outside the permissible range.

Nitrided Rolls are available for use in rolling special alloys such as Stainless Steel.

Component Parts Breakdown

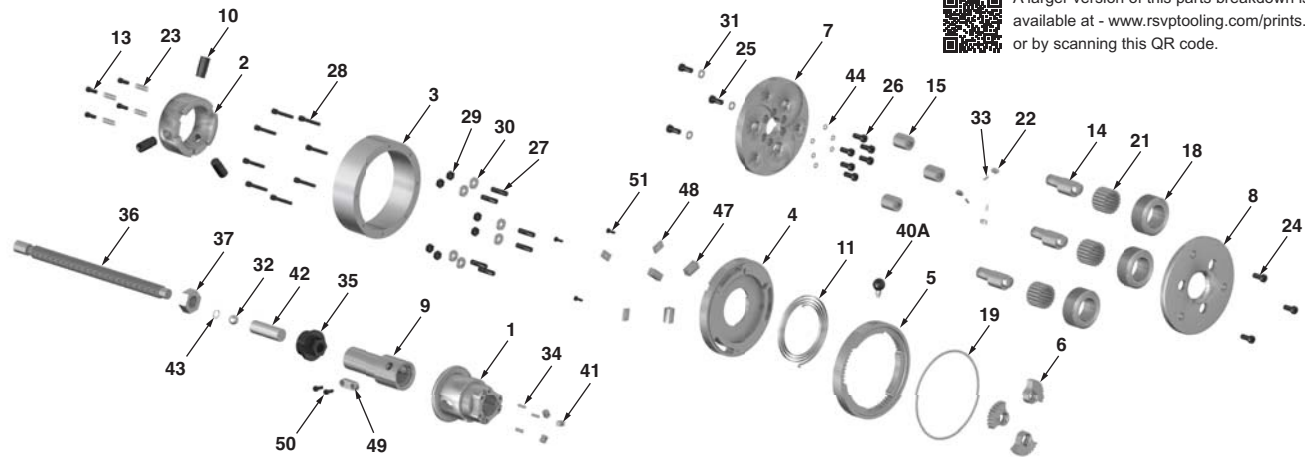

A larger version of this parts breakdown is available at - www.rsptooling.com/prints.html or by scanning this QR code.

Ref	Qty	Description	EDP
1	1	Flange	4-001
2	1	Clutch	4-002
3	1	Operating Ring	4-003
4	1	Spring Housing	4-004
5	1	Gear Ring	4-005
6	3	Gear Sectors	4-006
7	1	Center Plate	4-007
8	1	Front Plate	4-008
9	1	Shank 1-1/2	4-009
9A	1	Shank 2"	4-009A
9B	1	Shank 40mm	4-009B
9C	1	Shank 50mm	4-009C
10	1	Pin	4-010
11	1	Coil Spring	4-011
13	4	Spring Pin	4-013
14	3	Eccentric Spindles	4-014
15	3	Spacer Studs	4-015

Ref	Qty	Description	EDP
18	3	Thread Roll (See Chart for Size & EDP)	
19	116	Steel Ball	4-019
21	57	Needle Roller Bearings	4-021
21*	3	Carbide Bushing	1462
22	3	Fitting Key	4-022
23	4	Pressure Ring	4-023
24	3	Cap Screw	4-024
25	3	Cap Screw	4-025
26	6	Cap Screw	4-026
27	6	Stud	4-027
28	8	Cap Screw	4-028
29	6	Hex Nut	4-029
30	6	Washer	4-030
31	3	Lock Washer	4-031
32	1	Steel Ball	4-032
33	3	Shear Pins	4-033

Ref	Qty	Description	EDP
34	3	Roll Pins	4-034
35	1	Stop Screw Body	4-035
36	1	Stop Screw Body	4-036
37	1	Hex Nut	4-037
39	1	Hex Nut	4-039
40A	1	Handle Assy.	4-040A
41	3	Fitting Key	4-041
42	1	Rotating End Stop	4-042
43	1	Circlip	4-043
44	6	Circlip	4-044
47	3	Clutch Wedge	4-047
48	3	Cover Plate	4-048
49	1	Fitting Key	4-049
50	2	Cap Screw	4-050
51	3	Cap Screw	4-051

44 (*) #21 Needle Bearings are provided as standard. Optional Carbide Bushings provided at additional cost upon request.

A45 Axial Head

EDP	Shank	EDP	Shank
7113	1/1/02	7113-40	40mm
7113-2	2"	7121-50	50mm

Approximate Weight: 30 lbs

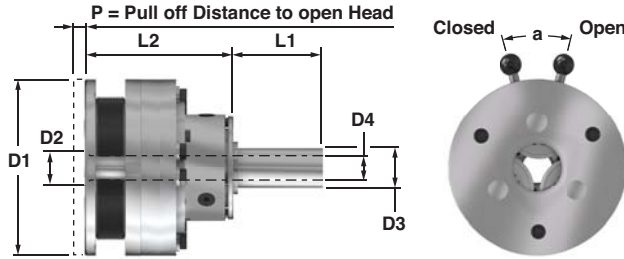

Axial Thread Rolling Heads For Right Hand Threads For Stationary Applications

A45 Axial Head Dimensions

Dimensions

Helix Angle in Head = 1° 10'		D1	D2	D3	D4
Allowable Component Lead	inches	6.339	1.890	1.5 / 2	1.100 / 1.260
Angle = 0° 40' - 1° 40'	mm	161	48	40 / 50	28 / 32

Dimensions Continued

Helix Angle in Head = 1° 10'		L1	L2	P	a
Allowable Component Lead	inches	2.953	6.220	0.157	30°
Angle = 0° 40' - 1° 40'	mm	75	158	4	

Left hand heads are dimensionally the same as right hand heads but open and close on the opposite direction. Thread rolls can be used in both right hand and left hand heads.

The Following Thread Rolls May Be Ordered As Standard On The A45 Axial Head

ISO Metric Fine		
1K EDP	2K EDP	Description
8771	8772	M16.0 - 18.0 x 1.0
8773	8774	M18.0 - 20.0 x 1.0
8775	8776	M20.0 - 22.0 x 1.0
8777	8778	M22.0 - 24.0 x 1.0
8779	8780	M18.0 - 20.0 x 1.5
8781	8782	M20.0 - 22.0 x 1.5
8783	8784	M22.0 - 24.0 x 1.5
8785	8786	M24.0 - 27.0 x 1.5
8787	8788	M27.0 - 30.0 x 1.5
8789	8790	M30.0 - 33.0 x 1.5
8791	8792	M33.0 - 36.0 x 1.5
8793	8794	M36.0 - 39.0 x 1.5*
8795	8796	M38.0 - 40.0 x 1.5*
8797	8798	M24.0 - 27.0 x 2.0
8799	8800	M27.0 - 30.0 x 2.0
8801	8804	M30.0 - 33.0 x 2.0
8803	8660	M33.0 - 36.0 x 2.0
8805	8806	M36.0 - 39.0 x 2.0*
8807	8808	M39.0 - 42.0 x 2.0

Unified Fine UNF		
1K EDP	2K EDP	Description
8809	8810	3/4 - 13/16 x 32
8811	8812	13/16 - 7/8 x 32
8813	8814	3/4 - 13/16 x 28
8815	8816	13/16 - 7/8 x 28
8817	8818	3/4 - 13/16 x 20
8819	8820	13/16 - 7/8 x 20
8821	8822	7/8 - 15/16 x 20
8823	8824	15/16 - 1 x 20
8825	8826	1 - 1-1/16 x 20
8827	8828	1-1/16 - 1-1/8 x 20
8829	8830	1-1/8 - 1-3/16 x 20
8831	8832	1-3/16 - 1-1/4 x 20
8833	8834	1-1/16 - 1-1/8 x 18
8835	8836	1-1/8 - 1-3/16 x 18
8837	8838	1-3/16 - 1-1/4 x 18
8839	8840	1-1/4 - 1-5/16 x 18
8841	8842	1-5/16 - 1-3/8 x 18
8843	8844	13/16 - 7/8 x 16
8845	8846	7/8 - 15/16 x 16

Unified Fine UNF (Continued)		
1K EDP	2K EDP	Description
8849	8850	15/16 - 1 x 16
8851	8852	1 - 1-1/16 x 16
8865	8848	1-1/16 - 1-1/8 x 16
2271	2272	1-1/8 - 1-3/16 x 16
8847	0934	1-3/16 - 1-1/4 x 16
8853	8854	1-1/4 - 1-5/16 x 16
8855	8856	1-5/16 - 1-3/8 x 16
8857	8858	1-3/8 - 1-7/16 x 16
8859	8860	1-7/16 - 1-1/2 x 16*
8861	8862	1-1/2 - 1-9/16 x 16*
2902	0954	7/8 x 14
2892	2890	1 - 1-1/16 x 12
8863	8864	1-1/16 - 1-1/8 x 12
0948	0927	1-1/8 - 1-3/16 x 12
1824	1825	1-3/16 - 1-1/4 x 12
8865	8866	1-1/4 - 1-5/16 x 12
8867	8868	1-5/16 - 1-3/8 x 12
8869	8870	1-3/8 - 1-7/16 x 12
8871	8872	1-7/16 - 1-1/2 x 12*
8873	8874	1-1/2 - 1-9/16 x 12*

National Pipe Thread NPT		
1K EDP	2K EDP	Description
8875	8876	3/4 x 14 NPT
8877	8878	1 x 11.5 NPT

National Pipe Thread Dryseal NPTF		
1K EDP	2K EDP	Description
8879	8880	3/4 x 14 NPTF
8881	8882	1 x 11.5 NPTF

(* Limited to short threads up to 28mm (1.102") including thread runoff

Threads outside of the above standard series may also be rolled on this head provided that their helix does not fall outside the permissible range.

Nitrided rolls are available for use in rolling special alloys such as Stainless Steel.

Component Parts Breakdown

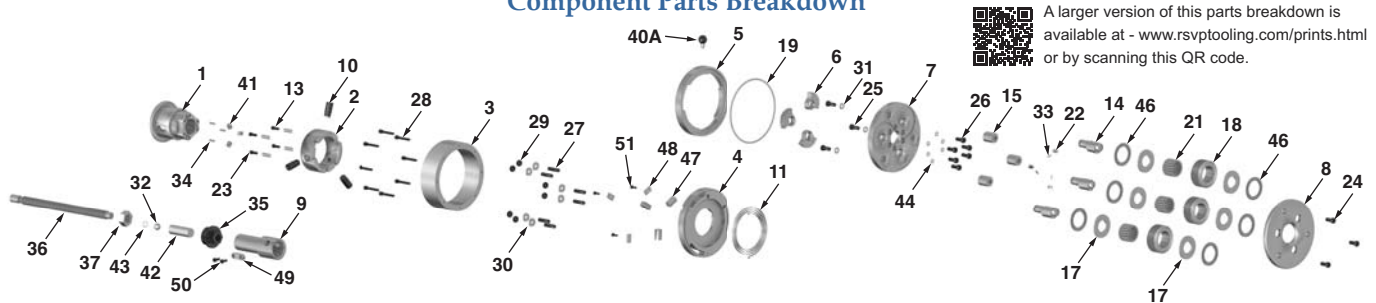

A larger version of this parts breakdown is available at - www.rsvptooling.com/prints.html or by scanning this QR code.

Ref	Qty	Description	EDP
1	1	Flange	4-001
2	1	Clutch	4-002
3	1	Operating Ring	4-003
4	1	Spring Housing	4-004
5	1	Gear Ring	4-005
6	3	Gear Sectors	45-006
7	1	Center Plate	45-007
8	1	Front Plate	45-008
9	1	Shank 1-1/2	4-009
9A	1	Shank 2"	4-009A
9B	1	Shank 40mm	4-009B
9C	1	Shank 50mm	4-009C
10	1	Pin	4-010
11	1	Coil Spring	4-011
13	4	Spring Pin	4-013
14	3	Eccentric Spindles	45-014
15	3	Spacer Studs	45-015
17	6	Axial Washer	45-017

Ref	Qty	Description	EDP
18	3	Thread Roll (See Chart for Size & EDP)	
19	116	Steel Ball	4-019
21	54	Needle Roller Bearings	7368
21*	3	Carbide Bushing	1460
22	3	Fitting Key	4-022
23	4	Pressure Ring	4-023
24	3	Cap Screw	4-024
25	3	Cap Screw	4-025
26	6	Cap Screw	4-026
27	6	Stud	4-027
28	8	Cap Screw	4-028
29	6	Hex Nut	4-029
30	6	Washer	4-030
31	3	Lock Washer	4-031
32	1	Steel Ball	4-032
33	3	Shear Pins	4-033
34	3	Roll Pins	4-034

Ref	Qty	Description	EDP
35	1	Stop Screw Body	4-035
36	1	Stop Screw Body	4-036
37	1	Hex Nut	4-037
39	1	Hex Nut	4-039
40A	1	Handle Assy.	4-040A
41	3	Fitting Key	4-041
42	1	Rotating End Stop	4-042
43	1	Circlip	4-043
44	6	Circlip	4-044
46	6	Axial Bearing Cage	45-046
47	3	Clutch Wedge	4-047
48	3	Cover Plate	4-048
49	1	Fitting Key	4-049
50	2	Cap Screw	4-050
51	3	Cap Screw	4-051

(*) #21 Needle Bearings are provided as standard. Optional Carbide Bushings provided at additional cost upon request.

A5 Axial Head

Axial Thread Rolling Heads
For Right Hand Threads
For Stationary Applications

EDP	Shank	EDP	Shank	EDP	Shank
7127	2"	7127-2.5	2/1/02	7127-60	60mm
7127-2.25	2/1/04	7127-50	50mm		

Approximate Weight: 58 lbs

A5 Axial Head Dimensions

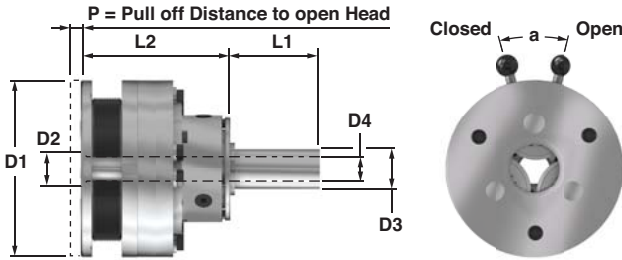

Dimensions

Helix Angle in Head = 2° 30'		D1	D2	D3	D4
Allowable Component Lead	inches	8.031	2.165	2 / 2.5	1.260 / 1.575
Angle = 1° 30' - 3°	mm	204	55	50 / 70	32 / 40

Dimensions Continued

Helix Angle in Head = 2° 30'		L1	L2	P	a
Allowable Component Lead	inches	3.740	6.850	0.197	30°
Angle = 1° 30' - 3°	mm	95	174	5	

Left hand heads are dimensionally the same as right hand heads but open and close on the opposite direction. Thread rolls can be used in both right hand and left hand heads.

The Following Thread Rolls May Be Ordered As Standard On The A5 Axial Head

ISO Metric			ISO Metric Fine			Unified Coarse UNC			Unified Fine UNF		
1K EDP	2K EDP	Description	1K EDP	2K EDP	Description	1K EDP	2K EDP	Description	1K EDP	2K EDP	Description
8714	8715	M18.0 - 20.0 x 2.5	8724	8725	M18.0 x 1.5	8700	8701	3/4 x 10	8708	8709	3/4 x 16
8716	8717	M20.0 - 22.0 x 2.5	8726	8727	M18.0 - 20.0 x 2.0	8734	8735	7/8 x 9	8710	8711	7/8 x 14
8718	8719	M24.0 - 27.0 x 3.0	8728	8729	M22.0 - 24.0 x 2.0	8702	8703	1" x 8	8712	8713	1 x 12
8720	8721	M30.0 - 33.0 x 3.5	8730	8731	M30.0 - 33.0 x 3.0	8704	1938	1-1/8 - 1-1/4 x 7			
8722	8723	M36.0 - 39.0 x 4.0	8732	8733	M33.0 - 36.0 x 3.0	8706	8707	1-3/8 - 1-1/2 x 6			

Threads outside of the above standard series may also be rolled on this head provided that their helix does not fall outside the permissible range.

Nitrided Rolls are available for use in rolling special alloys such as Stainless Steel.

Component Parts Breakdown

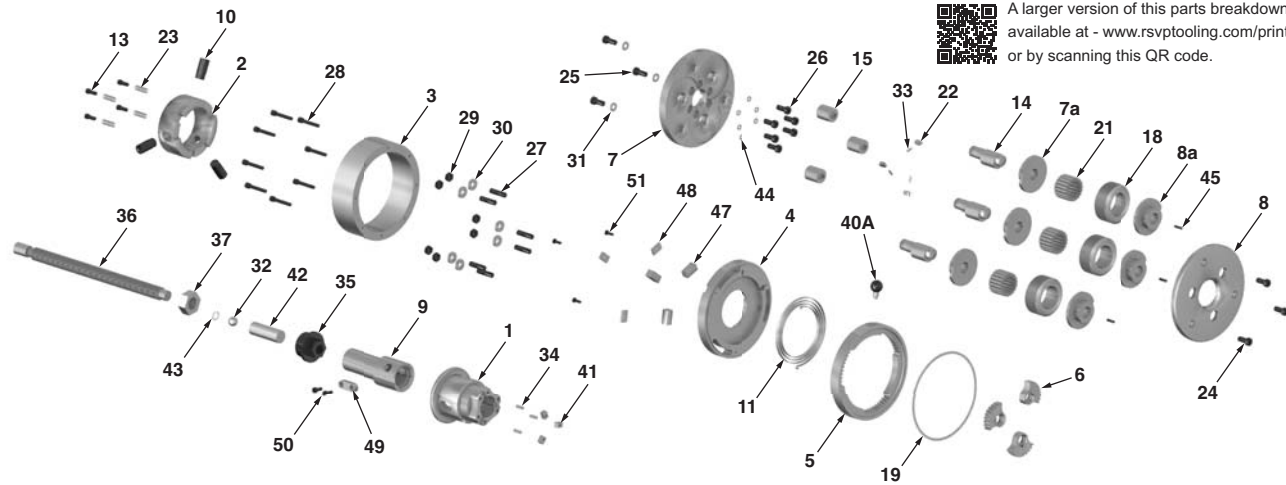

A larger version of this parts breakdown is available at - www.rsvpooling.com/prints.html or by scanning this QR code.

Ref	Qty	Description	EDP	Ref	Qty	Description	EDP	Ref	Qty	Description	EDP
1	1	Flange	5-001	14	3	Eccentric Spindles	5-014	33	3	Shear Pins	5-033
2	1	Clutch	5-002	15	3	Spacer Studs	5-015	34	3	Roll Pins	5-034
3	1	Operating Ring	5-003	18	3	Thread Roll (See Chart for Size & EDP)		35	1	Stop Screw Body	5-035
4	1	Spring Housing	5-004	19	145	Steel Ball	5-019	36	1	Stop Screw Body	5-036
5	1	Gear Ring	5-005	21	78	Needle Roller Bearings	5-021	37	1	Hex Nut	5-037
6	3	Gear Sectors	5-006	21*	3	Carbide Bushing	1457	39	3	Clutch Wedge	5-039
7	1	Center Plate	5-007	22	3	Fitting Key	5-022	40A	1	Handle Assy.	5-040A
7a	3	Center Plate Bushing	5-007a	23	3	Pressure Ring	5-023	41	3	Fitting Key	5-041
8	1	Front Plate	5-008	24	3	Cap Screw	5-024	42	1	Rotating End Stop	5-042
8a	3	Front Plate Bushing	5-008a	25	3	Cap Screw	5-025	43	1	Circlip	5-043
9	1	Shank 2"	5-009	26	6	Cap Screw	5-026	44	6	Circlip	5-044
9A		Shank 2-1/4	5-009A	27	6	Stud	5-027	45	3	Roll Pins	5-045
9B	1	Shank 2-1/2	5-009B	28	8	Cap Screw	5-028	48	3	Cover Plate	5-048
9C	1	Shank 50mm	5-009C	29	6	Hex Nut	5-029	49	1	Fitting Key	5-049
9D	1	Shank 60mm	5-009D	30	6	Washer	5-030	50	2	Cap Screw	5-050
10	1	Pin	5-010	31	3	Lock Washer	5-031	54	3	Cap Screw	5-054
11	1	Coil Spring	5-011	32	1	Steel Ball	5-032				
13	3	Spring Pin	5-013								

(* #21 Needle Bearings are provided as standard. Optional Carbide Bushings provided at additional cost upon request.

A56 Axial Head

Axial Thread Rolling Heads
For Right Hand Threads
For Stationary Applications

EDP	Shank	EDP	Shank	EDP	Shank
7120	2"	7120-2.5	2 1/2	7120-60	60mm
7120-2.25	2 1/4	7120-50	50mm		

Approximate Weight: 58 lbs

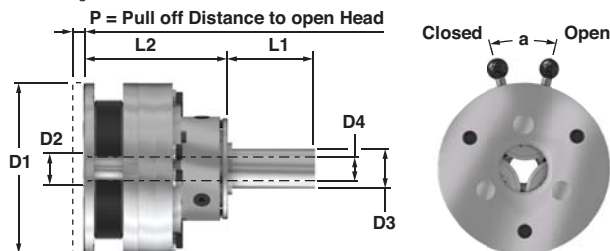

A56 Axial Head Dimensions

Dimensions

Helix Angle in Head = 1°		D1	D2	D3	D4
Allowable Component Lead	inches	8.031	2.283	2 / 2.5	1.260 / 1.575
Angle = 0° 35' - 3° 30'	mm	204	58	50 / 70	32 / 40

Dimensions Continued

Helix Angle in Head = 1°		L1	L2	P	a
Allowable Component Lead	inches	3.740	6.614	0.197	30°
Angle = 0° 35' - 3° 30'	mm	95	168	5	

Left hand heads are dimensionally the same as right hand heads but open and close on the opposite direction. Thread rolls can be used in both right hand and left hand heads.

The Following Thread Rolls May Be Ordered As Standard On The A56 Axial Head

ISO Metric Fine		
1K EDP	2K EDP	Description
8889	8890	M22.0 - 24.0 x 1.5
8891	8892	M24.0 - 27.0 x 1.5
8893	8894	M27.0 - 30.0 x 1.5
8895	8896	M30.0 - 33.0 x 1.5
8897	8898	M33.0 - 36.0 x 1.5
8899	8900	M36.0 - 39.0 x 1.5
8901	8902	M39.0 - 42.0 x 1.5
8903	8904	M42.0 - 45.0 x 1.5
8905	8906	M45.0 - 48.0 x 1.5*
8907	8908	M27.0 - 30.0 x 2.0
8909	8910	M30.0 - 33.0 x 2.0
8911	8912	M33.0 - 36.0 x 2.0
8913	8914	M36.0 - 39.0 x 2.0
8915	8916	M39.0 - 42.0 x 2.0
8917	8918	M42.0 - 45.0 x 2.0
8919	8920	M45.0 - 48.0 x 2.0*
8921	8689	M48.0 - 50.0 x 2.0*
8923	8924	M50.0 - 52.0 x 2.0*
8925	8926	M42.0 - 45.0 x 3.0

ISO Metric Fine (Continued)		
1K EDP	2K EDP	Description
8927	8928	M45.0 - 48.0 x 3.0*
8929	8930	M48.0 - 50.0 x 3.0*
8931	8932	M50.0 - 52.0 x 3.0*

Unified Fine UNF		
1K EDP	2K EDP	Description
8933	8934	7/8 - 1 x 32
8935	8936	7/8 - 1 x 28
8937	8938	1 - 1-1/8 x 28
8939	8940	1-1/8 - 1-1/4 x 28
8941	8942	1-1/4 - 1-5/16 x 28
8943	8944	7/8 - 1 x 20
8945	8946	1 - 1-1/8 x 20
8947	8948	1-1/8 - 1-1/4 x 20
8949	8950	1-1/4 - 1-3/8 x 20
8951	8952	1-3/8 - 1-1/2 x 20
8953	8954	1-1/16 - 1-3/16 x 18
8955	8956	1-3/16 - 1-5/16 x 18
8957	8958	1-5/16 - 1-7/16 x 18

Unified Fine UNF (Continued)		
1K EDP	2K EDP	Description
8959	8960	1-7/16 - 1-9/16 x 18
8961	8962	1-9/16 - 1-11/16 x 18
8963	8964	7/8 - 1 x 16
8965	8966	1 - 1-1/8 x 16
8967	8968	1-1/8 - 1-1/4 x 16
8969	8970	1-1/4 - 1-3/8 x 16
8971	8972	1-3/8 - 1-1/2 x 16
8973	8663	1-1/2 - 1-5/8 x 16
8975	8976	1-5/8 - 1-3/4 x 16
8977	8978	1-3/4 - 1-7/8 x 16*
8979	8980	1-7/8 - 2 x 16*
8981	8692	1-1/8 - 1-1/4 x 12
8983	8984	1-1/4 - 1-3/8 x 12
8985	8986	1-3/8 - 1-1/2 x 12
8987	8691	1-1/2 - 1-5/8 x 12
8989	8666	1-5/8 - 1-3/4 x 12
8991	8992	1-3/4 - 1-7/8 x 12*
8993	8994	1-7/8 - 2 x 12*
8995	8996	2* - 2-1/8** x 12

Unified Fine UNF (Continued)		
1K EDP	2K EDP	Description
8997	8998	1-3/4 - 1-7/8 x 8*
8999	8988	1-7/8 - 2 x 8*
8667	8668	2* - 2-1/8** x 12

National Pipe Thread NPT		
1K EDP	2K EDP	Description
8669	8670	3/4 x 14 NPT
8671	8672	1 x 11.5 NPT
8673	8674	1-1/4 x 11.5 NPT
8675	8676	1-1/2 x 11.5 NPT

National Pipe Thread Dryseal NPTF		
1K EDP	2K EDP	Description
8677	8678	3/4 x 14 NPTF
8679	8680	1 x 11.5 NPTF
8681	8682	1-1/4 x 11.5 NPTF
8683	8684	1-1/2 x 11.5 NPTF

(* Limited to short threads up to 95mm (3.74") including thread runout

(** Limited to short threads up to 38mm (1.496") including thread runout

Nitrided Rolls are available for use in rolling special alloys such as Stainless Steel.

Component Parts Breakdown

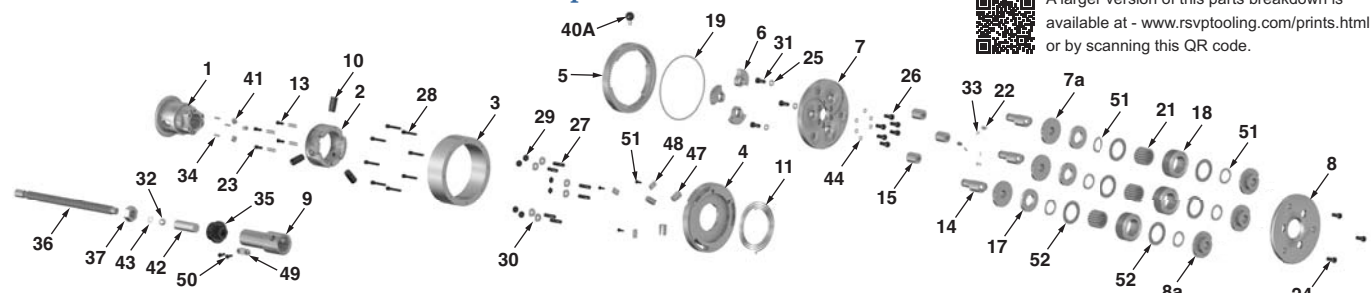

A larger version of this parts breakdown is available at - www.rsviewporting.com/prints.html or by scanning this QR code.

Ref	Qty	Description	EDP
1	1	Flange	5-001
2	1	Clutch	5-002
3	1	Operating Ring	5-003
4	1	Spring Housing	5-004
5	1	Gear Ring	5-005
6	3	Gear Sectors	56-006
7	1	Center Plate	56-007
7a	3	Center Plate Bushing	56-007a
8	1	Front Plate	56-008
8a	3	Front Plate Bushing	56-008a
9	1	Shank 2"	5-009
9A	1	Shank 2-1/4	5-009A
9B	1	Shank 2-1/2	5-009B
9C	1	Shank 50mm	5-009C
9D	1	Shank 60mm	5-009D
10	1	Pin	5-010
11	1	Coil Spring	5-011
13	3	Spring Pin	5-013

Ref	Qty	Description	EDP
14	3	Eccentric Spindles	56-014
15	3	Spacer Studs	56-015
17	3	Washer	56-017
18	3	Thread Roll	
(See Chart for Size & EDP)			
19	145	Steel Ball	5-019
21	57	Needle Roller Bearings	4-021
21*	3	Carbide Bushing	1462
22	3	Fitting Key	5-022
23	3	Pressure Ring	5-023
24	3	Cap Screw	5-024
25	3	Cap Screw	5-025
26	6	Cap Screw	5-026
27	6	Stud	5-027
28	8	Cap Screw	5-028
29	6	Hex Nut	5-029
30	6	Washer	5-030
31	3	Lock Washer	5-031

Ref	Qty	Description	EDP
32	1	Steel Ball	5-032
33	3	Shear Pins	5-033
34	3	Roll Pins	5-034
35	1	Stop Screw Body	5-035
36	1	Stop Screw Body	5-036
37	1	Hex Nut	5-037
39	3	Clutch Wedge	5-039
40A	1	Handle Assy.	5-040A
41	3	Fitting Key	5-041
42	1	Rotating End Stop	5-042
43	1	Circlip	5-043
44	6	Circlip	5-044
48	3	Cover Plate	5-048
49	1	Fitting Key	5-049
50	2	Cap Screw	5-050
51	6	Centering Ring	56-051
52	6	Axial Bearing Cage	56-052
54	3	Cap Screw	5-054

(*) #21 Needle Bearings are provided as standard. Optional Carbide Bushings provided at additional cost upon request.

AXIAL Operation

Operation

Thread rolling remains a simple and efficient process, provided the three main conditions listed below are met and adhered to at all times:

The material to be rolled must be suitable for thread rolling. Attempting to roll unsuitable material may at best give poor thread quality, and at worst cause severe damage to both the rolls and the thread rolling head.

The correct rolling speed should be selected according to the material being rolled and the profile of the thread form required. Reference to material properties, and the rolling speeds chart will enable the correct spindle speed to be calculated. For most standard V-form threads such as unified, metric & Whitworth, 100 ft/min (30m/min) should be considered as the absolute minimum speed, with only Acme, trapezoidal and similar thread forms being attempted at speeds as low as 65 ft/min (20m/min). Attempting to roll at too low a speed will most likely result in premature thread roll failure. Conversely, a higher rolling speed will often improve a material's rolling characteristics, thus improving thread roll life.

An adequate supply of good quality coolant is essential for successful thread rolling, as it is for most machining processes. The choice between neat cutting oils and water soluble is often governed by the type of machine being used or, where applicable, the user's environmental/health and safety policy. While neat cutting oils normally possess superior lubricating and extreme pressure properties, they do not dissipate heat away from the rolls as efficiently as water soluble solutions, unless some type of refrigeration unit is incorporated into the coolant system. When mixing soluble oils it is advisable to maximize the ratio of oil to water, as this gives the best combination of lubrication and cooling properties needed for thread rolling. Finally, once the choice of coolant has been made, ensure the supply is both copious and free of metallic particles. An insufficient supply will soon result in the rolls overheating, while particulate contamination can cause damage to the thread rolls, their bearings and the head mechanism.

Having satisfied the principal machining conditions outlined above, the following steps should be followed when setting up for each thread size:

Blank Preparation

Such is the variety of components that can be rolled it is impossible to illustrate the pre-rolling blank for every application. However, with few exceptions, component blanks fall in to one of three following categories:

A. Rod/tube drawn or ground to pre-rolling size.

When producing studs, linkages, U-bolts, conduit and similar parts, pre-machining can be eliminated by careful selection of material stock that has been drawn or ground to the correct pre-rolling diameter. The increasing popularity of thread rolling has resulted in rod and tube mills offering many standard materials in a range of pre-rolling diameters for most commercial thread sizes. It is often found the blank diameter will be at or within .002"/.05mm of the threads effective diameter, but before committing production to any given supply of bar stock, it is advisable to run sample batches in order to determine that both the basic stock size and tolerance will suit the application. Consideration should be given to the fact that a variation in blank diameter will affect the resultant major diameter by a ratio of approximately three to one when rolling directly on to bar stock. For example, if a drawn rod is supplied with a tolerance of nominal size 0.0/-0.002" (0.0/-0.05mm), then the rolled major diameter will have a tolerance band of 0.006" (0.15mm) which is allowable for most threads of class 2A and 6G fit. If a tighter tolerance on major diameter is required, then ground stock should be considered ahead of drawn stock.

Once the correct diameter of bar or tube has been selected, it only remains for the blank to be pre-chamfered to facilitate the initial engagement of the rolls and leave the finished piece part with a clean lead in thread (See figures 3 & 4).



Figure: 3 Pre-rolled rod



Figure: 4 Rod after rolling

B. Blank pre-turned up to a shoulder.

Most thread rolling applications involve the piece part being turned in the spindle prior to the actual rolling process. This has the distinct advantage the blank and the rolling head will be in line which eliminates the problems involved with misalignment. The required blank diameter will need to be determined by machining several trial parts to the following procedure:

1. The rolling head has to be adjusted as close as possible to its final running position. With the head in its closed position, a plain plug, turned to the minor diameter of the thread, is placed between the thread rolls in the head. The three nuts (part number 15) are slackened off and the head is adjusted down so that the rolls grip the plug. The plug is then removed and the head adjusted down 1/2 a division on the graduated scale to remove any play in the bearings.

2. The piece part is turned down to the pitch diameter, minus .002" / .05mm, with a chamfer machined to .010"-.020" (.25mm-.5mm) below the root diameter. The angle of the chamfer should be no more than 30 degrees to the axis, with 20-25 degrees being ideal (See figure 5). After rolling, the resultant chamfer should be approximately 45 degrees, due to the flow of material at this point (figure 6).

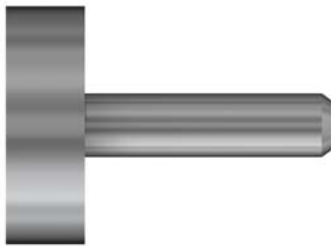

Figure: 5 Before rolling

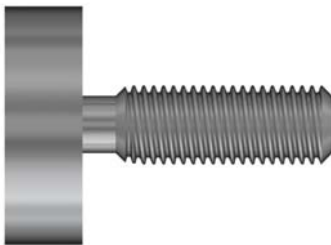

Figure: 6 After rolling

3. The opening position of the rolling head is then determined by advancing it forward, in the open condition, until the front faces of the rolls are just short of the shoulder. On a conventional machine, the mechanical stops would be set at this point, whereas on a CNC machine the Z-axis position should be noted and used as the end point in the program. This procedure should be undertaken with the spindle stationary and as previously stated, with the head in the open condition.

4. With the head set to the approximate size, and the blank turned to the lowest estimate of the required pre-rolling diameter, the first attempt at rolling is then made, using the appropriate spindle speed for the thread being rolled and advancing the head at, or just below, the required feed rate (1 X pitch/rev). At the opening position the head stops advancing, allowing it to pull off and trip open as the drive coupling disengages between the shank and spring housing. (A short, half a second dwell on the machine cam or in the CNC program is required to allow the head to open before it is retracted).

It is most likely that the first component rolled following the above procedure will be oversize on the pitch diameter and undersize on the major diameter. If this is the case, then the next step is to adjust the head down another 1/2 division on the graduated scale and then roll another test piece. By adjusting the head down, the pitch diameter will decrease, while the major diameter will increase. After just one or two further test pieces, the pitch diameter should be established to suit the gauges, but the major diameter may still be undersized. If this is the case, calculate the amount by which the major diameter needs to increase and adjust the blank diameter up by a third of this amount. Ideally, when both the pitch and the major diameters are at the middle limit of their tolerances, the crest of the thread should have a slight truncation and not quite be fully formed. A fully formed thread, while giving a smooth and polished appearance, is a sign of over rolling which causes over stressing of the rolls and reduces their working life.

C. Thread rolling into an undercut

The same principles for thread rolling up to a shoulder apply when thread rolling into an undercut, except for the blank profile at the undercut itself. Here, the chamfer is machined on the front of the blank must also be machined at the undercut, as illustrated in figure 7.

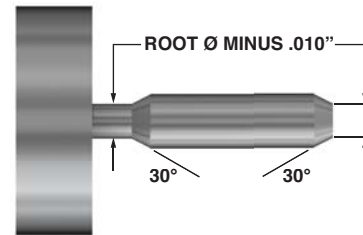

Figure: 7 Blank with undercut

In selecting the width of undercut, consideration should be given for the length of run out required when the thread rolling head opens. Axial thread rolls are available with two standard styles of lead: 1K and 2K.

Rolls designated 1K have one modified lead thread that enables the rolls to engage on the end of the blank and allows for the material to be progressively formed up to the full thread depth. Chosen as the standard short lead, these rolls generate a runout length of $2.3 \times P$, where P is the pitch of the thread being rolled. This formula allows for the length of the lead on the rolls and for the opening action of the thread rolling head and is therefore only a close approximation. In practice, it may be found that a shorter runout is obtained when a sample component is rolled.

Note: If the standard 1K lead is too long for the desired undercut, rolls can be supplied with special extra short leads of 0.6K or even 0.3K. However, by concentrating the rolling process into a shorter lead, roll life can be significantly

reduced. Subsequently, 0.6 and 0.3K leads are only recommended on low tensile, ductile materials.

The preferred standard lead for most thread rolling applications is 2K, as this spreads the working load over two start threads on each roll, giving a general increase in roll life over 1K lead rolls. Due to the extra lead thread on each roll, the runout length on the component will increase by one extra pitch. The following examples show the runout for each type of lead on some typical threads:

Length	Runout Lead	Thread formula	Runout size
0.3 K	1.6 x Pitch	M6 x 1	1.6mm
0.6 K	2 x Pitch	7/16 x 20 UNF	0.10"
1 K	2.3 x Pitch	M14 x 2	4.6mm
2 K	3.3 x Pitch	3/4 x 10 UNC	0.33"

Assembling Rolls Into Head

Remove the front plate screws to release the front plate, revealing the eccentric spindles on which the thread rolls are to be mounted. For the A0 head, which has 2 rolls, the rolls are assembled 1-2 or A-B while for all right hand 3 roll heads, the rolls are assembled 1,2,3 or A,B,C in a clockwise direction as viewed by the operator (for left hand thread rolling heads, rolls are assembled counter clockwise). Before assembly, it is recommended to smear all contact surfaces with a good quality lubricating grease or paste to minimize friction and wear. This will help protect the rolls, needle bearings and eccentric spindles which perform at high speeds under severe loads.

With the rolls in the correct sequence, insert the needle bearings or carbide bushes, replace the front plate and secure tightly with the front plate screws. Always ensure that the full amount of needle bearings are loaded between the rolls and the eccentric spindles (refer to head breakdown). For example, the A2 head requires 57 needle bearings, which is 19 per roll. Insufficient needle bearings in just one roll will reduce accuracy,

promote roll failure and cause excessive wear to the eccentric spindle. This potential problem is eliminated by the use of carbide bushings, which are also quicker and easier to replace and allow roll changeovers to be accomplished with the head still mounted in the machine turret.

With the rolls assembled and the front plate tightened down, it should be possible to rotate the rolls freely by hand. The head can now be adjusted to suit the thread to be rolled by following this simple procedure:

- Ensure the head is in the closed condition.
- Loosen the 3 nuts (part number 15) which will allow the front cage of the head to be rotated relative to the spring housing. Note the setting line and graduated scale. As the head is adjusted in the minus direction (-), the rolls close down, opening outwards when the head is adjusted in the plus (+) direction.
- The head can now be adjusted down on to a setting piece, which can be a screwed sample or a plain plug machined to the minor diameter of the thread. If the head is adjusted to either the + or - limit, and is still not to size, remove the 3 nuts and ring washer (part number 16). The front cage assembly is then removed, rotated about 120 degrees in the desired direction of adjustment, and then reassembled on the spring housing. Another indicator will then line up at one end of the graduated scale, permitting further adjustment in the desired direction.
- When the head has been successfully adjusted down on to the setting piece, the 3 nuts can then be re-tightened. The first component to be rolled at this setting is invariably oversize, and the head will then need to be adjusted down in 1/2 division increments until the desired pitch diameter is achieved. Any necessary alterations to the blank diameter can now be made to produce the correct major diameter on the thread.



Axial Rolling head with standard needle bearings installed



Axial Rolling head with optional Carbide Bushings installed

AXIAL Problem Solving

Fault / Condition	Probable Cause	Remedy
Major diameter is under size with truncated form, but the pitch diameter is correct	The pre-rolling blank diameter is undersize	Increase the pre-rolling blank diameter in small increments until correct major is obtained
Major diameter is undersize with truncated form and the pitch diameter is oversize	Thread rolling head is not adjusted correctly to size	Adjust thread rolling head down This will decrease the pitch but increase the major diameter
Both major diameter and pitch diameter are oversize	Blank diameter is oversize Head is adjusted oversize	Reduce blank diameter and readjust head, then follow setup procedure
The first 2 or 3 threads are rough or malformed	The approach rate of the thread rolling head is too fast or too slow	Check feed cam, programmed feed rate or hydraulic system according to type used
	Chamfer angle is too high or not uniform	Check that chamfer is not more than 30 degrees to the axis and is smooth/uniform
	The thread rolling head and component are misaligned	Check that the thread rolling head is on center with spindle
Thread slivers/flakes	Insufficient ductility	Change material/grade
	Material is leaded for free cutting	If other machining parameters permit, change to a low or non leaded grade of material
	Swarf/metal particles present in the coolant	Flush out and change coolant Improve filtration system
	Over rolling Thread form is full	Reduce blank diameter until thread form starts to truncate
Poor finish on thread	Thread rolls worn or chipped on the leads	Reverse rolls in the head before the leads chip. Replace badly damaged rolls
Component is bent or out of round	Blank is bent prior to rolling or bends during rolling	Material has inherent stress Anneal material
	Blank is not perfectly round	Check pre-turning operation particularly on long threads
	Thread rolling head and component are misaligned	Check that the thread rolling head is on center with spindle

AXIAL Lead Angles Based On Basic Pitch Diameter

For UN Threads

Diameter			Threads per inch													
Inches	mm		80	72	64	56	50	48	44	40	36	32	30	28	26	24
No. 0	0.060	1.52	4°23'	4°57'	5°42'	6°42'	7°43'	8° 8'	9° 6'	10°21'	11°55'	14° 6'				
No. 1	0.073	1.85	3°30'	3°57'	4°31'	5°17'	6° 3'	6°16'	7° 5'	8° 2'	9° 9'	10°43'				
No. 2	0.086	2.18	2°56'	3°17'	3°46'	4°22'	4°59'	5°14'	5°48'	6°31'	7°25'	8°37'	9°23'			
No. 3	0.099	2.51	2°30'	2°49'	3°12'	3°43'	4°14'	4°26'	4°55'	5°30'	6°14'	7°13'	7°44'	8°32'	9°25'	9°16'
No. 4	0.112	2.84	2°12'	2°27'	2°48'	3°14'	3°41'	3°51'	4°15'	4°45'	5°23'	6°12'	6°43'	7°18'	8° 2'	8°53'
No. 5	0.125	3.18	1°57'	2°11'	2°29'	2°52'	3°16'	3°24'	3°45'	4°11'	4°46'	5°26'	5°52'	6°22'	7° 0'	7°43'
No. 6	0.138	3.51	1°45'	1°58'	2°14'	2°34'	2°55'	3° 3'	3°21'	3°44'	4°13'	4°50'	5°13'	5°39'	6°12'	6°50'
No. 8	0.164	4.17	1°28'	1°38'	1°51'	2° 5'	2°25'	2°27'	2°43'	3° 5'	3°28'	3°58'	4°32'	4°37'	5° 2'	5°32'
No. 10	0.190	4.83	1°15'	1°24'	1°35'	1°49'	2° 5'	2° 9'	2°22'	2°37'	2°56'	3°21'	3°40'	3°54'	4°25'	4°39'
No. 12	0.216	5.49	1° 6'	1°13'	1°23'	1°36'	1°46'	1°53'	2° 3'	2°17'	2°33'	2°55'	3° 6'	3°22'	3°37'	4° 1'
1/4"	0.250	6.35	0°57'	1° 3'	1°12'	1°22'	1°33'	1°37'	1°46'	1°57'	2°11'	2°24'	2°40'	2°53'	3° 7'	3°24'
9/32"	0.281	7.14	0°50'	0°56'	1° 3'	1°12'	1°22'	1°25'	1°34'	1°43'	1°56'	2°11'	2°21'	2°31'	2°44'	3° 0'
5/16"	0.313	7.95	0°45'	0°50'	0°57'	1° 5'	1°13'	1°16'	1°24'	1°33'	1°43'	1°57'	2° 5'	2°15'	2°27'	2°40'
11/32"	0.344	8.74	0°40'	0°45'	0°51'	0°59'	1° 6'	1° 9'	1°15'	1°24'	1°34'	1°46'	1°54'	2° 2'	2°12'	2°24'
3/8"	0.375	9.53	0°37'	0°41'	0°47'	0°54'	1° 1'	1° 3'	1° 9'	1°16'	1°25'	1°37'	1°43'	1°51'	2° 0'	2°11'
13/32"	0.406	10.31	0°34'	0°38'	0°43'	0°50'	0°56'	0°58'	1° 4'	1°10'	1°18'	1°29'	1°35'	1°42'	1°50'	2° 0'
7/16"	0.438	11.13	0°32'	0°36'	0°40'	0°46'	0°52'	0°54'	0°59'	1° 5'	1°12'	1°22'	1°27'	1°34'	1°42'	1°51'
15/32"	0.469	11.91	0°30'	0°33'	0°37'	0°43'	0°48'	0°50'	0°55'	1° 1'	1° 8'	1°17'	1°22'	1°27'	1°35'	1°43'
1/2"	0.500	12.70	0°28'	0°31'	0°35'	0°40'	0°45'	0°47'	0°52'	0°57'	1° 3'	1°12'	1°16'	1°22'	1°29'	1°37'
17/32"	0.531	13.49		0°33'	0°38'	0°42'	0°44'	0°48'	0°53'	0°59'	1° 7'	1°11'	1°17'	1°24'	1°30'	1°30'
9/16"	0.563	14.30			0°31'	0°36'	0°40'	0°42'	0°45'	0°50'	0°56'	1° 3'	1° 8'	1°12'	1°18'	1°25'
19/32"	0.594	15.09			0°29'	0°34'	0°38'	0°39'	0°43'	0°47'	0°53'	1° 0'	1° 4'	1° 9'	1°14'	1°20'
5/8"	0.625	15.88			0°28'	0°32'	0°36'	0°37'	0°41'	0°45'	0°50'	0°57'	1° 0'	1° 5'	1°10'	1°17'
11/16"	0.688	17.48			0°25'	0°29'	0°33'	0°34'	0°37'	0°41'	0°46'	0°51'	0°55'	0°59'	1° 4'	1° 9'
3/4"	0.750	19.05			0°23'	0°27'	0°30'	0°31'	0°34'	0°37'	0°42'	0°47'	0°50'	0°54'	0°58'	1° 3'
13/16"	0.813	20.65				0°25'	0°27'	0°29'	0°31'	0°35'	0°38'	0°43'	0°46'	0°50'	0°53'	0°58'
7/8"	0.875	22.23				0°23'	0°25'	0°27'	0°29'	0°32'	0°36'	0°40'	0°43'	0°46'	0°50'	0°54'
15/16"	0.938	23.83				0°21'	0°24'	0°25'	0°27'	0°30'	0°33'	0°37'	0°40'	0°43'	0°46'	0°50'
1"	1.000	25.40				0°20'	0°22'	0°23'	0°25'	0°28'	0°31'	0°35'	0°37'	0°40'	0°43'	0°47'
1.1/16"	1.063	27.00				0°19'	0°21'	0°22'	0°24'	0°26'	0°29'	0°33'	0°35'	0°38'	0°41'	0°44'
1.1/8"	1.125	28.58				0°18'	0°20'	0°21'	0°23'	0°25'	0°28'	0°31'	0°33'	0°36'	0°38'	0°42'
1.3/16"	1.188	30.18				0°17'	0°19'	0°20'	0°21'	0°24'	0°26'	0°29'	0°31'	0°34'	0°36'	0°39'
1.1/4"	1.250	31.75				0°16'	0°18'	0°19'	0°20'	0°22'	0°25'	0°28'	0°30'	0°32'	0°35'	0°37'
1.5/16"	1.313	33.35				0°15'	0°17'	0°18'	0°19'	0°21'	0°24'	0°26'	0°28'	0°30'	0°33'	0°36'
1.3/8"	1.375	34.93				0°14'	0°17'	0°17'	0°18'	0°20'	0°23'	0°25'	0°27'	0°29'	0°31'	0°34'
1.7/16"	1.438	36.53								0°19'	0°22'	0°24'	0°26'	0°28'	0°30'	0°32'
1.1/2"	1.500	38.10								0°18'	0°21'	0°23'	0°25'	0°27'	0°29'	0°31'
1.5/8"	1.625	41.28										0°21'	0°23'	0°24'	0°26'	0°29'
1.3/4"	1.750	44.45										0°20'	0°21'	0°22'	0°24'	0°27'
1.7/8"	1.875	47.63										0°18'	0°20'	0°21'	0°23'	0°25'
2"	2.000	50.80										0°17'	0°18'	0°20'	0°21'	0°23'



AXIAL Lead Angles Based On Basic Pitch Diameter

For UN Threads

Diameter			Threads per inch													
Inches	mm		20	18	16	14	13	12	11	10	9	8	7	6	5	4.5
No. 0	0.060	1.52														
No. 1	0.073	1.85														
No. 2	0.086	2.18														
No. 3	0.099	2.51														
No. 4	0.112	2.84														
No. 5	0.125	3.18	9°46'	11°16'	13°18'											
No. 6	0.138	3.51	8°35'	9°51'	11°30'											
No. 8	0.164	4.17	6°55'	7°50'	9°10'	10°57'	12° 9'	13°36'								
No. 10	0.190	4.83	5°47'	6°34'	7°36'	9° 1'	9°56'	11° 4'								
No. 12	0.216	5.49	4°58'	5°37'	6°28'	7°39'	8°24'	9°19'	10°29'							
1/4"	0.250	6.35	4°12'	4°43'	5°26'	6°23'	6°59'	7°43'	8°38'	9°47'						
9/32"	0.281	7.14	3°40'	4° 9'	4°43'	5°32'	6° 3'	6°40'	7°26'	8°23'						
5/16"	0.313	7.95	3°15'	3°40'	4°12'	4°53'	5°20'	5°52'	6°32'	7°20'	8°23'	9°46'				
11/32"	0.344	8.74	2°51'	3°17'	3°46'	4°26'	4°46'	5°15'	5°49'	6°31'	7°26'	8°38'				
3/8"	0.375	9.53	2°47'	3° 0'	3°24'	3°58'	4°20'	4°43'	5°15'	5°52'	6°40'	7°44'				
13/32"	0.406	10.31	2°27'	2°44'	3° 7'	3°37'	3°47'	4°26'	4°46'	5°20'	6° 3'	6°59'	8°16'	10° 7'		
7/16"	0.438	11.13	2°15'	2°31'	2°53'	3°20'	3°37'	3°58'	4°24'	4°53'	5°32'	6°23'	7°32'	9°10'	11°43'	
15/32"	0.469	11.91	2° 5'	2°20'	2°40'	3°00'	3°21'	3°40'	4° 3'	4°30'	5° 6'	5°52'	6°55'	8°26'	10°40'	
1/2"	0.500	12.70	1°57'	2°11'	2°29'	2°53'	3° 7'	3°24'	3°46'	4°12'	4°43'	5°26'	6°23'	7°44'	9°46'	11°16'
17/32"	0.531	13.49	1°50'	2° 3'	2°20'	2°41'	2°55'	3°12'	3°31'	3°57'	4°24'	5° 3'	5°56'	7°10'	9° 2'	10° 3'
9/16"	0.563	14.30	1°43'	1°55'	2°11'	2°31'	2°44'	3° 0'	3°17'	3°40'	4° 9'	4°44'	5°32'	6°40'	8°23'	9°37'
19/32"	0.594	15.09	1°38'	1°49'	2° 4'	2°23'	2°35'	2°49'	3° 6'	3°27'	3°59'	4°27'	5°12'	6°15'	7°50'	8°57'
5/8"	0.625	15.88	1°33'	1°43'	1°57'	2°15'	2°27'	2°40'	2°56'	3°15'	3°40'	4°11'	4°53'	5°52'	7°20'	8°23'
11/16"	0.688	17.48	1°24'	1°34'	1°46'	2° 2'	2°12'	2°24'	2°38'	2°56'	3°17'	3°46'	4°24'	5°14'	6°31'	7°26'
3/4"	0.750	19.05	1°16'	1°25'	1°37'	1°51'	2° 0'	2°11'	2°24'	2°40'	3° 0'	3°24'	3°58'	4°43'	5°52'	6°40'
13/16"	0.813	20.65	1°10'	1°18'	1°29'	1°42'	1°50'	2° 0'	2°12'	2°27'	2°44'	3° 7'	3°37'	4°20'	5°20'	6° 3'
7/8"	0.875	22.23	1° 5'	1°12'	1°22'	1°34'	1°42'	1°51'	2° 2'	2°15'	2°32'	2°53'	3°20'	3°28'	4°53'	5°32'
15/16"	0.938	23.83	1° 1'	1° 8'	1°16'	1°27'	1°35'	1°43'	1°54'	2° 5'	2°20'	2°40'	3° 6'	3°40'	4°30'	5° 6'
1"	1.000	25.40	0°57'	1° 3'	1°12'	1°22'	1°29'	1°37'	1°46'	1°57'	2°11'	2°29'	2°53'	3°24'	4°12'	4°44'
1.1/16"	1.063	27.00	0°53'	0°59'	1° 7'	1°17'	1°24'	1°31'	1°39'	1°56'	2° 3'	2°20'	2°41'	3°12'	3°55'	4°24'
1.1/8"	1.125	28.58	0°50'	0°56'	1° 3'	1°13'	1°18'	1°25'	1°34'	1°43'	1°56'	2°11'	2°32'	3° 0'	3°40'	4° 8'
1.3/16"	1.188	30.18	0°47'	0°53'	1° 0'	1° 9'	1°14'	1°21'	1°28'	1°38'	1°49'	2° 4'	2°23'	2°49'	3°27'	3°53'
1.1/4"	1.250	31.75	0°45'	0°50'	0°57'	1° 5'	1°10'	1°16'	1°24'	1°33'	1°43'	1°57'	2°15'	2°40'	3°15'	3°40'
1.5/16"	1.313	33.35	0°43'	0°48'	0°54'	1° 2'	1° 7'	1°12'	1°19'	1°27'	1°38'	1°51'	2° 8'	2°31'	3° 6'	3°29'
1.3/8"	1.375	34.93	0°41'	0°45'	0°51'	0°59'	1° 4'	1° 9'	1°15'	1°24'	1°34'	1°46'	2° 2'	2°24'	2°56'	3°17'
1.7/16"	1.438	36.53	0°39'	0°43'	0°49'	0°56'	1° 1'	1° 6'	1°12'	1°20'	1°29'	1°41'	1°56'	2°17'	2°47'	3° 8'
1.1/2"	1.500	38.10	0°37'	0°42'	0°47'	0°54'	0°58'	1° 3'	1° 9'	1°16'	1°25'	1°36'	1°51'	2°11'	2°40'	3° 0'
1.5/8"	1.625	41.28	0°34'	0°38'	0°43'	0°50'	0°53'	0°58'	1° 4'	1°10'	1°18'	1°29'	1°42'	2° 0'	2°26'	2°44'
1.3/4"	1.750	44.45	0°32'	0°36'	0°40'	0°46'	0°50'	0°54'	0°59'	1° 5'	1°12'	1°22'	1°34'	1°52'	2°15'	2°31'
1.7/8"	1.875	47.63	0°30'	0°33'	0°37'	0°43'	0°46'	0°50'	0°55'	1° 1'	1° 8'	1°17'	1°28'	1°43'	2° 5'	2°20'
2"	2.000	50.80	0°28'	0°31'	0°35'	0°40'	0°43'	0°47'	0°51'	0°57'	1° 3'	1°11'	1°22'	1°37'	1°57'	2°11'

AXIAL Lead Angles Based On Basic Pitch Diameter

For Metric Screw Threads M Profile

Diameter		Pitch										
mm	inches	0.30	0.35	0.40	0.45	0.50	0.60	0.70	0.75	0.80	1.00	1.25
1.4	0.055	4° 32'	5° 26'	6° 22'	7° 22'							
1.6	0.063	3° 53'	4° 38'	5° 26'	6° 15'	7° 7'						
1.8	0.071	3° 24'	4° 3'	4° 44'	5° 26'	6° 9'						
2.0	0.079	3° 2'	3° 36'	4° 11'	4° 48'	5° 26'	6° 46'					
2.2	0.087	2° 44'	3° 14'	3° 45'	4° 18'	4° 51'	6° 1'	7° 17'				
2.5	0.098	2° 22'	2° 48'	3° 15'	3° 43'	4° 11'	5° 10'	6° 13'	6° 46'	7° 20'		
3.0	0.118	1° 57'	2° 18'	2° 40'	3° 2'	3° 24'	4° 11'	5° 0'	5° 26'	5° 52'		
3.5	0.138	1° 39'	1° 57'	2° 15'	2° 33'	2° 52'	3° 31'	4° 11'	4° 32'	4° 53'	6° 22'	
4.0	0.157	1° 26'	1° 41'	1° 57'	2° 13'	2° 29'	3° 2'	3° 36'	3° 53'	4° 11'	5° 26'	7° 7'
4.5	0.177	1° 16'	1° 30'	1° 43'	1° 57'	2° 11'	2° 40'	3° 9'	3° 24'	3° 40'	4° 44'	6° 9'
5.0	0.197	1° 8'	1° 20'	1° 32'	1° 45'	1° 57'	2° 22'	2° 48'	3° 2'	3° 15'	4° 11'	5° 26'
6.0	0.236	0° 57'	1° 6'	1° 16'	1° 26'	1° 36'	1° 57'	2° 18'	2° 29'	2° 40'	3° 24'	4° 23'
6.3	0.248	0° 54'	1° 3'	1° 12'	1° 22'	1° 32'	1° 51'	2° 11'	2° 21'	2° 31'	3° 13'	4° 9'
8.0	0.315	0° 42'	0° 49'	0° 57'	1° 4'	1° 11'	1° 26'	1° 41'	1° 49'	1° 57'	2° 29'	3° 10'
10.0	0.394	0° 33'	0° 39'	0° 45'	1° 51'	0° 57'	1° 8'	1° 20'	1° 26'	1° 32'	1° 57'	2° 29'
12.0	0.472	0° 28'	0° 33'	0° 37'	0° 42'	0° 47'	0° 57'	1° 6'	1° 11'	1° 16'	1° 36'	2° 2'
14.0	0.551	0° 24'	0° 28'	0° 32'	0° 36'	0° 40'	0° 48'	0° 57'	1° 1'	1° 5'	1° 22'	1° 44'
16.0	0.630	0° 21'	0° 24'	0° 28'	0° 31'	0° 35'	0° 42'	0° 49'	0° 53'	0° 57'	1° 11'	1° 30'
18.0	0.709		0° 22'	0° 25'	0° 28'	0° 31'	0° 37'	0° 44'	0° 47'	0° 50'	1° 3'	1° 20'
20.0	0.787			0° 22'	0° 25'	0° 28'	0° 33'	0° 39'	0° 42'	0° 45'	0° 57'	1° 11'
22.0	0.866			0° 20'	0° 23'	0° 25'	0° 30'	0° 36'	0° 38'	0° 41'	0° 51'	1° 5'
24.0	0.945				0° 21'	0° 23'	0° 28'	0° 33'	0° 35'	0° 37'	0° 47'	0° 59'
27.0	1.063					0° 21'	0° 25'	0° 29'	0° 31'	0° 33'	0° 42'	0° 52'
30.0	1.181						0° 22'	0° 26'	0° 28'	0° 30'	0° 37'	0° 47'
33.0	1.299						0° 20'	0° 24'	0° 25'	0° 27'	0° 34'	0° 42'
36.0	1.417							0° 22'	0° 23'	0° 25'	0° 31'	0° 39'
39.0	1.535							0° 20'	0° 21'	0° 23'	0° 29'	0° 36'
42.0	1.654								0° 20'	0° 21'	0° 26'	0° 33'
45.0	1.772									0° 20'	0° 25'	0° 31'
48.0	1.890										0° 23'	0° 29'
52.0	2.047										0° 21'	0° 27'

Diameter		Pitch										
mm	inches	1.50	1.75	2.00	2.50	3.00	3.50	4.00	4.50	5.00	5.50	6.00
1.4	0.055											
1.6	0.063											
1.8	0.071											
2.0	0.079											
2.2	0.087											
2.5	0.098											
3.0	0.118											
3.5	0.138											
4.0	0.157											
4.5	0.177											
5.0	0.197	6° 46'										
6.0	0.236	5° 26'	6° 32'									
6.3	0.248	5° 7'	6° 9'	7° 15'								
8.0	0.315	3° 53'	4° 38'	5° 26'	7° 7'							
10.0	0.394	3° 2'	3° 36'	4° 11'	5° 26'	6° 46'						
12.0	0.472	2° 29'	2° 56'	3° 24'	4° 23'	5° 26'	6° 32'					
14.0	0.551	2° 6'	2° 29'	2° 52'	3° 41'	4° 32'	5° 26'	6° 22'	7° 22'			
16.0	0.630	1° 49'	2° 9'	2° 29'	3° 10'	3° 53'	4° 38'	5° 26'	6° 15'	7° 7'		
18.0	0.709	1° 36'	1° 54'	2° 11'	2° 47'	3° 24'	4° 3'	4° 44'	5° 26'	6° 9'	6° 55'	
22.0	0.866	1° 18'	1° 32'	1° 46'	2° 14'	2° 44'	3° 14'	3° 45'	4° 18'	4° 51'	5° 26'	6° 1'
24.0	0.945	1° 11'	1° 24'	1° 36'	2° 2'	2° 29'	2° 56'	3° 24'	3° 53'	4° 23'	4° 54'	5° 26'
27.0	1.063	1° 3'	1° 14'	1° 25'	1° 48'	2° 11'	2° 35'	2° 59'	3° 24'	3° 50'	4° 16'	4° 44'
30.0	1.181	0° 57'	1° 6'	1° 16'	1° 36'	1° 57'	2° 18'	2° 40'	3° 2'	3° 24'	3° 47'	4° 11'
33.0	1.299	0° 51'	1° 0'	1° 9'	1° 27'	1° 46'	2° 5'	2° 24'	2° 44'	3° 4'	3° 24'	3° 45'
36.0	1.417	0° 47'	0° 55'	1° 3'	1° 20'	1° 36'	1° 54'	2° 11'	2° 29'	2° 47'	3° 5'	3° 24'
39.0	1.535	0° 43'	0° 51'	0° 58'	1° 13'	1° 29'	1° 44'	2° 0'	2° 16'	2° 33'	2° 50'	3° 7'
42.0	1.654	0° 40'	0° 47'	0° 54'	1° 8'	1° 22'	1° 36'	1° 51'	2° 6'	2° 21'	2° 37'	2° 52'
45.0	1.772	0° 37'	0° 44'	0° 50'	1° 3'	1° 16'	1° 30'	1° 43'	1° 57'	2° 11'	2° 25'	2° 40'
48.0	1.890	0° 35'	0° 41'	0° 47'	0° 59'	1° 11'	1° 24'	1° 36'	1° 49'	2° 2'	2° 15'	2° 29'
52.0	2.047	0° 32'	0° 38'	0° 43'	0° 54'	1° 6'	1° 17'	1° 29'	1° 40'	1° 52'		



AXIAL Recommended Blank Diameters

Blank Diameters For Parallel Rolled Threads UNF & UNC - Class 2

Size		Steel													Aluminum Alloy				
		10-50 C Soft		30-50 C Soft		30-50 C or Alloy 15-25 RC		30-50 C Chrome Nickel 26-32 RC		Stainless Chrome 300 Series*		Stainless Chrome 400 Series*		Brass and Bronze		Soft		Hard	
O.D.	Pitch	Max.	Min.	Max.	Min.	Max.	Min.	Max.	Min.	Max.	Min.	Max.	Min.	Max.	Min.	Max.	Min.	Max.	Min.
#0	80	.0504	.0498	.0507	.0501	.0509	.0503	.0511	.0505	.0513	.0507	.0515	.0509	.0507	.0501	.0509	.0503	.0507	.0501
#1	72	.0623	.0617	.0627	.0621	.0629	.0622	.0631	.0625	.0633	.0626	.0635	.0628	.0627	.06321	.0629	.0622	.0627	.0621
#1	64	.0612	.0605	.0616	.0609	.0618	.0611	.0620	.0613	.0622	.0615	.0624	.0617	.0616	.0609	.0618	.0611	.0616	.0609
#2	64	.0742	.0735	.0746	.0739	.0748	.0741	.0750	.0743	.0752	.0745	.0754	.0747	.0746	.0739	.0748	.0741	.0746	.0739
#2	56	.0726	.0719	.0730	.0723	.0732	.0725	.0734	.0728	.0737	.0730	.0739	.0732	.0730	.0723	.0732	.0725	.0730	.0723
#3	56	.0855	.0847	.0859	.0852	.0861	.0854	.0863	.0856	.0866	.0858	.0868	.0860	.0859	.0852	.0861	.0854	.0859	.0852
#3	48	.0835	.0827	.0840	.0832	.0842	.0834	.0844	.0837	.0846	.0839	.0849	.0841	.0840	.0832	.0842	.0834	.0840	.0832
#4	48	.0964	.0956	.0969	.0961	.0971	.0964	.0974	.0966	.0976	.0968	.0979	.0971	.0969	.0961	.0971	.0964	.0969	.0961
#4	40	.0936	.0928	.0941	.0933	.0943	.0935	.0946	.0938	.0948	.0940	.0951	.0943	.0941	.0938	.0943	.0935	.0941	.0933
#5	44	.1081	.1073	.1086	.1078	.1088	.1080	.1091	.1082	.1093	.1085	.1096	.1088	.1086	.1078	.1088	.1080	.1086	.1078
#5	40	.1065	.1057	.1070	.1062	.1073	.1064	.1075	.1067	.1078	.1070	.1081	.1072	.1070	.1062	.1073	.1064	.1070	.1062
#6	40	.1195	.1187	.1200	.1192	.1203	.1194	.1205	.1197	.1208	.1200	.1211	.1202	.1200	.1192	.1203	.1194	.1200	.1192
#6	32	.1153	.1144	.1159	.1149	.1161	.1152	.1164	.1155	.1167	.1158	.1170	.1161	.1159	.1149	.1161	.1152	.1159	.1149
#8	36	.1436	.1427	.1442	.1432	.1444	.1435	.1447	.1438	.1450	.1441	.1453	.1444	.1442	.1432	.1444	.1435	.1442	.1432
#8	32	.1412	.1402	.1417	.1408	.1420	.1411	.1423	.1414	.1426	.1416	.1429	.1419	.1417	.1408	.1420	.1411	.1417	.1408
#10	32	.1671	.1661	.1677	.1667	.1680	.1670	.1683	.1673	.1686	.1676	.1689	.1679	.1677	.1667	.1680	.1670	.1677	.1667
#10	24	.1591	.1589	.1608	.1596	.1611	.1599	.1614	.1602	.1618	.1606	.1621	.1609	.1608	.1596	.1611	.1599	.1608	.1596
#12	28	.1900	.1889	.1907	.1896	.1910	.1899	.1913	.1902	.1916	.1905	.1920	.1908	.1907	.1896	.1910	.1899	.1907	.1896
#12	24	.1861	.1848	.1868	.1855	.1871	.1859	.1874	.1862	.1878	.1865	.1881	.1869	.1868	.1855	.1871	.1859	.1868	.1855
1/4	20	.2144	.2131	.2151	.2138	.2155	.2142	.2159	.2146	.2166	.2153	.2159	.2146	.2151	.2138	.2155	.2142	.2151	.2138
1/4	28	.2241	.2228	.2248	.2235	.2251	.2238	.2255	.2242	.2261	.2248	.2255	.2242	.2248	.2235	.2251	.2238	.2248	.2235
5/16	18	.2729	.2716	.2737	.2724	.2741	.2728	.2745	.2732	.2753	.2740	.2745	.2732	.2737	.2724	.2741	.2728	.2737	.2724
5/16	24	.2823	.2810	.2830	.2817	.2834	.2821	.2837	.2824	.2845	.2832	.2837	.2824	.2830	.2817	.2834	.2821	.2830	.2817
3/8	16	.3306	.3291	.3315	.3300	.3320	.3305	.3324	.3309	.3333	.3318	.3324	.3309	.3315	.3300	.3320	.3305	.3315	.3300
3/8	24	.3448	.3434	.3455	.3441	.3459	.3445	.3463	.3449	.3471	.3457	.3463	.3449	.3455	.3441	.3459	.3445	.3455	.3441
7/16	14	.3871	.3855	.3880	.3864	.3885	.3869	.3890	.3874	.3899	.3883	.3890	.3874	.3880	.3864	.3885	.3869	.3880	.3864
7/16	20	.4012	.3999	.4021	.4008	.4025	.4012	.4029	.4016	.4037	.4024	.4029	.4016	.4021	.4008	.4025	.4012	.4021	.4008
1/2	13	.4458	.4440	.4468	.4450	.4473	.4455	.4478	.4460	.4488	.4470	.4478	.4460	.4468	.4450	.4473	.4455	.4468	.4450
1/2	20	.4637	.4623	.4646	.4632	.4650	.4636	.4655	.4641	.4663	.4649	.4655	.4641	.4646	.4632	.4650	.4636	.4646	.4632
9/16	12	.5039	.5021	.5050	.5032	.5055	.5037	.5060	.5042	.5070	.5052	.5060	.5042	.5050	.5032	.5055	.5037	.5050	.5032
9/16	18	.5225	.5210	.5234	.5219	.5238	.5223	.5243	.5228	.5252	.5237	.5243	.5228	.5234	.5219	.5238	.5223	.5234	.5219
5/8	11	.5614	.5595	.5625	.5606	.5630	.5611	.5636	.5617	.5647	.5628	.5636	.5617	.5625	.5606	.5630	.5611	.5625	.5606
5/8	18	.5850	.5833	.5859	.5842	.5864	.5847	.5869	.5852	.5878	.5861	.5869	.5852	.5859	.5842	.5864	.5847	.5859	.5842
3/4	10	.6799	.6779	.6811	.6791	.6817	.6797	.6823	.6803	.6834	.6814	.6823	.6803	.6811	.6791	.6817	.6797	.6811	.6791
3/4	16	.7052	.7034	.7062	.7044	.7067	.7049	.7072	.7054	.7082	.7064	.7072	.7054	.7062	.7044	.7067	.7049	.7062	.7044
7/8	9	.7972	.7952	.7985	.7965	.7991	.7971	.7998	.7978	.8010	.7990	.7998	.7978	.7985	.7965	.7991	.7971	.7985	.7965
7/8	14	.8240	.8221	.8251	.8232	.8257	.8238	.8262	.8243	.8273	.8259	.8262	.8243	.8251	.8232	.8257	.8238	.8251	.8232
1	8	.9131	.9107	.9144	.9120	.9151	.9127	.9158	.9134	.9172	.9148	.9158	.9134	.9144	.9120	.9151	.9127	.9144	.9120
1	12	.9408	.9388	.9420	.9400	.9426	.9406	.9432	.9412	.9443	.9423	.9432	.9412	.9420	.9400	.9426	.9406	.9420	.9400
1-1/8	7	1.0262	1.0235	1.0276	1.0250	1.0283	1.0257	1.0290	1.0264	1.0304	1.0278	1.0290	1.0264	1.0276	1.0250	1.0283	1.0257	1.0276	1.0250
1-1/8	12	1.0657	1.0637	1.0669	1.0649	1.0675	1.0655	1.0681	1.0661	1.0693	1.0673	1.0681	1.0661	1.0669	1.0649	1.0675	1.0655	1.0669	1.0649
1-1/4	7	1.1510	1.1483	1.1525	1.1498	1.1533	1.1506	1.1540	1.1513	1.1555	1.1528	1.1540	1.1513	1.1525	1.1498	1.1533	1.1506	1.1525	1.1498
1-1/4	12	1.1906	1.1885	1.1919	1.1898	1.1925	1.1904	1.1931	1.1910	1.1943	1.1922	1.1931	1.1910	1.1919	1.1898	1.1925	1.1904	1.1919	1.1898
1-3/8	6	1.2601	1.2571	1.2617	1.2587	1.2625	1.2595	1.2633	1.2603	1.2649	1.2619	1.2633	1.2603	1.2617	1.2587	1.2625	1.2595	1.2617	1.2587
1-3/8	12	1.3153	1.3133	1.3166	1.3146	1.3171	1.3152	1.3178	1.3158	1.3191	1.3171	1.3178	1.3158	1.3166	1.3146	1.3171	1.3152	1.3166	1.3146
1-1/2	6	1.3850	1.3820	1.3866	1.3836	1.3874	1.3844	1.3882	1.3852	1.3898	1.3868	1.3882	1.3851	1.3866	1.3836	1.3874	1.3844	1.3866	1.3836
1-1/2	12	1.4402	1.4382	1.4415	1.4395	1.4422	1.4402	1.4428	1.4408	1.4441	1.4421	1.4428	1.4408	1.4415	1.4395	1.4422	1.4402	1.4415	1.4395
1-3/4	5	1.6124	1.6094	1.6142	1.6112	1.6150	1.6120	1.6159	1.6129	1.6177	1.6147	1.6159	1.6129	1.6142	1.6112	1.6150	1.6120	1.6142	1.6112
2	4-1/2	1.8474	1.8442	1.8493	1.8461	1.8503	1.8471	1.8512	1.8480	1.8531	1.8499	1.8512	1.8480	1.8442	1.8461	1.8503	1.8471	1.8442	1.8461

Note: These dimensions are for set-up reference. Diameters must be finally established by actual rolling.

• Only Certain Grades Rollable

AXIAL Recommended Blank Diameters

Blank Diameters For Parallel Rolled Threads UNF & UNC - Class 3

Size		Steel													Aluminum Alloy				
		10-50 C Soft		30-50 C Soft		30-50 C or Alloy 15-25 RC		30-50 C Chrome Nickel 26-32 RC		Stainless Chrome 300 Series*		Stainless Chrome 400 Series*		Brass and Bronze		Soft		Hard	
		Max.	Min.	Max.	Min.	Max.	Min.	Max.	Min.	Max.	Min.	Max.	Min.	Max.	Min.	Max.	Min.	Max.	Min.
#0	80	.0512	.0507	.0514	.0510	.0515	.0511	.0517	.0513	.0519	.0515	.0517	.0513	.0514	.0510	.0515	.0511	.0514	.0510
#1	72	.0632	.0627	.0635	.0630	.0637	.0632	.0638	.0633	.0641	.0636	.0638	.0633	.0635	.0630	.0637	.0632	.0635	.0630
#1	64	.0621	.0616	.0624	.0619	.0625	.0620	.0627	.0622	.0630	.0625	.0627	.0622	.0624	.0619	.0625	.0620	.0624	.0619
#2	64	.0751	.0746	.0754	.0749	.0755	.0750	.0757	.0752	.0760	.0755	.0757	.0752	.0754	.0749	.0755	.0750	.0754	.0749
#2	56	.0735	.0730	.0738	.0733	.0739	.0734	.0741	.0736	.0744	.0739	.0741	.0736	.0738	.0733	.0739	.0734	.0738	.0733
#3	56	.0865	.0860	.0868	.0863	.0869	.0864	.0871	.0866	.0874	.0869	.0871	.0866	.0868	.0863	.0869	.0864	.0868	.0863
#3	48	.0845	.0840	.0848	.0843	.0850	.0845	.0852	.0847	.0855	.0850	.0852	.0847	.0848	.0843	.0850	.0845	.0848	.0843
#4	48	.0975	.0969	.0978	.0972	.0980	.0974	.0982	.0976	.0986	.0980	.0982	.0976	.0978	.0972	.0980	.0974	.0978	.0972
#4	40	.0947	.0941	.0950	.0945	.0953	.0947	.0955	.0949	.0958	.0952	.0955	.0949	.0950	.0945	.0953	.0947	.0950	.0945
#5	44	.1091	.1085	.1095	.1088	.1097	.1091	.1099	.1093	.1102	.1096	.1099	.1093	.1095	.1088	.1097	.1091	.1095	.1088
#5	40	.1077	.1071	.1081	.1075	.1083	.1077	.1085	.1079	.1088	.1082	.1085	.1079	.1081	.1075	.1083	.1077	.1081	.1075
#6	40	.1207	.1200	.1211	.1204	.1213	.1206	.1215	.1208	.1219	.1212	.1215	.1208	.1211	.1204	.1213	.1206	.1211	.1204
#6	32	.1164	.1157	.1169	.1162	.1171	.1164	.1174	.1167	.1178	.1171	.1174	.1167	.1169	.1162	.1171	.1164	.1169	.1162
#8	36	.1448	.1441	.1452	.1445	.1454	.1447	.1457	.1450	.1461	.1454	.1457	.1450	.1452	.1445	.1454	.1447	.1452	.1445
#8	32	.1424	.1417	.1429	.1422	.1431	.1424	.1433	.1426	.1437	.1430	.1433	.1426	.1429	.1422	.1431	.1424	.1429	.1422
#10	32	.1683	.1676	.1688	.1681	.1690	.1683	.1693	.1686	.1697	.1690	.1693	.1686	.1688	.1681	.1690	.1683	.1688	.1681
#10	24	.1615	.1607	.1620	.1612	.1622	.1614	.1625	.1617	.1630	.1622	.1625	.1617	.1620	.1612	.1622	.1614	.1620	.1612
#12	28	.1913	.1906	.1918	.1911	.1921	.1914	.1923	.1916	.1928	.1921	.1923	.1916	.1918	.1911	.1921	.1914	.1918	.1911
#12	24	.1874	.1866	.1879	.1871	.1881	.1873	.1884	.1876	.1889	.1881	.1884	.1876	.1879	.1871	.1881	.1873	.1879	.1871
1/4	20	.2159	.2150	.2164	.2155	.2167	.2158	.2170	.2161	.2176	.2167	.2170	.2161	.2164	.2155	.2167	.2158	.2164	.2155
1/4	28	.2254	.2246	.2259	.2251	.2261	.2253	.2264	.2256	.2269	.2261	.2264	.2256	.2259	.2251	.2261	.2253	.2259	.2251
5/16	18	.2724	.2737	.2753	.2743	.2756	.2746	.2759	.2749	.2765	.2755	.2759	.2749	.2753	.2743	.2756	.2746	.2753	.2743
5/16	24	.2839	.2830	.2845	.2836	.2847	.2838	.2850	.2841	.2855	.2846	.2850	.2841	.2845	.2836	.2847	.2838	.2845	.2836
3/8	16	.3326	.3314	.3333	.3321	.3336	.3324	.3340	.3328	.3346	.3334	.3340	.3328	.3334	.3324	.3340	.3328	.3333	.3321
3/8	24	.3463	.3453	.3469	.3459	.3472	.3462	.3475	.3465	.3480	.3470	.3475	.3465	.3469	.3459	.3472	.3462	.3469	.3459
7/16	14	.3893	.3880	.3900	.3887	.3903	.3890	.3907	.3894	.3914	.3901	.3907	.3894	.3900	.3887	.3903	.3890	.3900	.3887
7/16	20	.4032	.4022	.4038	.4028	.4041	.4031	.4044	.4034	.4051	.4041	.4044	.4034	.4038	.4028	.4041	.4031	.4038	.4028
1/2	13	.4480	.4467	.4487	.4474	.4491	.4478	.4495	.4482	.4502	.4489	.4495	.4482	.4487	.4474	.4491	.4478	.4487	.4474
1/2	20	.4657	.4646	.4664	.4653	.4664	.4654	.4670	.4659	.4676	.4665	.4670	.4659	.4664	.4653	.4664	.4654	.4664	.4653
9/16	12	.5062	.5049	.5070	.5057	.5070	.5057	.5078	.5065	.5085	.5072	.5078	.5065	.5070	.5057	.5070	.5057	.5070	.5057
9/16	18	.5246	.5233	.5253	.5240	.5253	.5240	.5260	.5247	.5267	.5254	.5260	.5247	.5253	.5240	.5253	.5240	.5253	.5240
5/8	11	.5636	.5623	.5644	.5631	.5644	.5631	.5653	.5640	.5661	.5648	.5653	.5640	.5644	.5631	.5644	.5631	.5644	.5631
5/8	18	.5871	.5858	.5878	.5865	.5878	.5865	.5885	.5872	.5892	.5879	.5885	.5872	.5878	.5865	.5878	.5865	.5878	.5865
3/4	10	.6825	.6810	.6834	.6819	.6834	.6819	.6843	.6828	.6852	.6837	.6843	.6828	.6834	.6819	.6834	.6819	.6834	.6819
3/4	16	.7073	.7060	.7080	.7067	.7080	.7067	.7088	.7075	.7096	.7083	.7088	.7075	.7080	.7067	.7080	.7067	.7087	.7067
7/8	9	.8002	.7986	.8010	.7994	.8011	.7995	.8021	.8005	.8030	.8014	.8021	.8005	.8010	.7994	.8011	.7995	.8010	.7994
7/8	14	.8262	.8249	.8270	.8257	.8270	.8257	.8279	.8266	.8287	.8274	.8279	.8266	.8270	.8257	.8270	.8257	.8270	.8257
1	8	.9160	.9142	.9170	.9151	.9170	.9152	.9180	.9162	.9191	.9173	.9180	.9162	.9170	.9152	.9170	.9152	.9170	.9152
1	12	.9434	.9419	.9443	.9428	.9443	.9428	.9452	.9437	.9461	.9446	.9452	.9437	.9443	.9428	.9443	.9428	.9443	.9428
1-1/8	7	1.0292	1.0273	1.0303	1.0284	1.0303	1.0284	1.0314	1.0295	1.0325	1.0306	1.0314	1.0295	1.0303	1.0284	1.0303	1.0284	1.0303	1.0284
1-1/8	12	1.0684	1.0669	1.0693	1.0678	1.0693	1.0678	1.0693	1.0678	1.0711	1.0696	1.0693	1.0678	1.0693	1.0678	1.0693	1.0678	1.0693	1.0678
1-1/4	7	1.1542	1.1523	1.1553	1.1534	1.1553	1.1534	1.1553	1.1534	1.1575	1.1556	1.1553	1.1534	1.1553	1.1539	1.1553	1.1534	1.1553	1.1534
1-1/4	12	1.1933	1.1918	1.1942	1.1927	1.1942	1.1927	1.1951	1.1936	1.1960	1.1945	1.1951	1.1936	1.1942	1.1927	1.1942	1.1927	1.1942	1.1927
1-3/8	6	1.2633	1.2613	1.2645	1.2625	1.2651	1.2631	1.2657	1.2637	1.2665	1.2649	1.2657	1.2637	1.2645	1.2625	1.2651	1.2631	1.2645	1.2625
1-3/8	12	1.3182	1.3167	1.3191	1.3176	1.3196	1.3181	1.3200	1.3185	1.3210	1.3195	1.3200	1.3185	1.3191	1.3176	1.3196	1.3181	1.3191	1.3176
1-1/2	6	1.3883	1.3862	1.3894	1.3874	1.3900	1.3880	1.3906	1.3886	1.3918	1.3898	1.3906	1.3886	1.3894	1.3874	1.3900	1.3880	1.3894	1.3874
1-1/2	12	1.4433	1.4416	1.4442	1.4425	1.4447	1.4430	1.4451	1.4434	1.4461	1.4444	1.4451	1.4434	1.4442	1.4425	1.4447	1.4430	1.4442	1.4435
1-3/4	5	1.6165	1.6141	1.6178	1.6154	1.6185	1.6161	1.6191	1.6167	1.6205	1.6181	1.6191	1.6167	1.6178	1.6154	1.6185	1.6161	1.6178	1.6159
2	4-1/2	1.8518	1.8493	1.8532	1.8507	1.8539	1.8514	1.8546	1.8521	1.8561	1.8536	1.8546	1.8521	1.8532	1.8507	1.8539	1.8514	1.8532	1.8507

Note: These dimensions are for set-up reference. Diameters must be finally established by actual rolling.

* Only Certain Grades Rollable



AXIAL Recommended Blank Diameters

Blank Diameters In Inches For Straight, Metric Threads

Size in MM		Steel												Aluminum Alloy						
		10-50 C Soft		30-50 C Soft		30-50 C or Alloy 15-25 RC		30-50 C Chrome Nickel 26-32 RC		Stainless Chrome 300 Series*		Stainless Chrome 400 Series*		Brass and Bronze		Soft		Hard		
O.D.	Pitch	Max.	Min.	Max.	Min.	Max.	Min.	Max.	Min.	Max.	Min.	Max.	Min.	Max.	Min.	Max.	Min.	Max.	Min.	
3	.35	In.	.1085	.1080	.1088	.1083	.1090	.1085	.1091	.1086	.1094	.1089	.1091	.1086	.1088	.1083	.1090	.1085	.1088	.1083
3	.5	In.	.1044	.1039	.1047	.1042	.1049	.1044	.1050	.1045	.1053	.1048	.1050	.1045	.1047	.1042	.1049	.1044	.1047	.1042
3.5	.35	In.	.1282	.1277	.1284	.1279	.1286	.1281	.1287	.1282	.1290	.1285	.1287	.1282	.1284	.1279	.1286	.1281	.1284	.1279
3.5	.6	In.	.1214	.1209	.1218	.1213	.1219	.1214	.1221	.1216	.1224	.1219	.1221	.1216	.1218	.1213	.1219	.1214	.1218	.1213
4	.5	In.	.1438	.1433	.1441	.1436	.1442	.1437	.1444	.1439	.1447	.1442	.1444	.1439	.1441	.1436	.1442	.1437	.1441	.1436
4	.7	In.	.1386	.1380	.1389	.1383	.1391	.1385	.1393	.1387	.1397	.1391	.1393	.1387	.1389	.1383	.1391	.1385	.1389	.1383
4.5	.5	In.	.1635	.1630	.1638	.1633	.1639	.1634	.1641	.1636	.1644	.1639	.1641	.1636	.1638	.1633	.1639	.1634	.1638	.1633
5	.5	In.	.1831	.1826	.1835	.1830	.1836	.1831	.1837	.1832	.1841	.1836	.1837	.1832	.1835	.1830	.1836	.1831	.1835	.1830
5	.8	In.	.1754	.1747	.1757	.1751	.1759	.1753	.1761	.1755	.1765	.1758	.1761	.1755	.1757	.1751	.1759	.1753	.1757	.1751
6	.75	In.	.2159	.2153	.2163	.2157	.2165	.2159	.2167	.2161	.2170	.2164	.2167	.2161	.2163	.2157	.2165	.2159	.2163	.2157
6	1.0	In.	.2092	.2084	.2097	.2089	.2100	.2092	.2102	.2094	.2107	.2099	.2102	.2094	.2097	.2089	.2100	.2092	.2097	.2089
7	.75	In.	.2553	.2547	.2557	.2551	.2559	.2553	.2561	.2555	.2564	.2558	.2561	.2551	.2557	.2551	.2559	.2553	.2557	.2551
7	1.0	In.	.2486	.2478	.2491	.2483	.2494	.2486	.2496	.2488	.2501	.2493	.2496	.2488	.2491	.2483	.2494	.2486	.2491	.2483
8	1.0	In.	.2880	.2872	.2885	.2877	.2888	.2880	.2890	.2882	.2895	.2887	.2890	.2882	.2885	.2877	.2888	.2880	.2885	.2877
8	1.25	In.	.2815	.2807	.2820	.2812	.2822	.2814	.2825	.2817	.2830	.2822	.2825	.2817	.2820	.2812	.2822	.2814	.2820	.2812
9	1.0	In.	.3273	.3265	.3278	.3270	.3281	.3273	.3283	.3275	.3288	.3280	.3283	.3275	.3278	.3270	.3281	.3273	.3278	.3270
9	1.25	In.	.3209	.3201	.3214	.3206	.3216	.3208	.3219	.3211	.3224	.3216	.3219	.3211	.3214	.3206	.3216	.3208	.3214	.3206
10	1.0	In.	.3667	.3659	.3672	.3664	.3675	.3667	.3677	.3669	.3682	.3674	.3677	.3669	.3672	.3664	.3675	.3667	.3672	.3664
10	1.5	In.	.3537	.3529	.3543	.3535	.3546	.3538	.3549	.3541	.3554	.3546	.3549	.3541	.3543	.3535	.3546	.3538	.3543	.3535
11	1.5	In.	.3930	.3919	.3936	.3925	.3939	.3928	.3942	.3932	.3948	.3938	.3942	.3932	.3936	.3925	.3939	.3928	.3936	.3925
12	1.5	In.	.4324	.4313	.4330	.4319	.4333	.4322	.4336	.4326	.4342	.4332	.4336	.4326	.4330	.4319	.4333	.4322	.4330	.4319
12	1.75	In.	.4259	.4246	.4266	.4253	.4269	.4256	.4273	.4260	.4280	.4267	.4273	.4260	.4266	.4253	.4269	.4256	.4266	.4253
14	1.5	In.	.5111	.5100	.5117	.5106	.5120	.5109	.5123	.5113	.5129	.5119	.5123	.5113	.5117	.5106	.5120	.5109	.5117	.5106
14	2	In.	.4979	.4966	.4986	.4973	.4990	.4977	.4994	.4981	.5002	.4989	.4994	.4981	.4986	.4973	.4990	.4977	.4986	.4973
16	1.5	In.	.5899	.5888	.5905	.5894	.5908	.5897	.5911	.5901	.5917	.5907	.5911	.5901	.5905	.5894	.5908	.5897	.5905	.5894
16	2	In.	.5767	.5754	.5774	.5761	.5778	.5765	.5782	.5769	.5790	.5777	.5782	.5769	.5774	.5761	.5778	.5765	.5774	.5761
18	1.5	In.	.6686	.6675	.6692	.6681	.6695	.6684	.6698	.6688	.6704	.6694	.6698	.6688	.6692	.6681	.6695	.6684	.6692	.6681
18	2.5	In.	.6422	.6407	.6431	.6416	.6435	.6420	.6440	.6425	.6449	.6434	.6440	.6425	.6431	.6416	.6435	.6420	.6431	.6416
20	1.5	In.	.7474	.7463	.7480	.7469	.7483	.7472	.7486	.7476	.7492	.7482	.7486	1.7476	.7480	.7469	.7483	.7472	.7480	.7469
20	2.5	In.	.7210	.7195	.7219	.7204	.7223	.7208	.7228	.7213	.7237	.7222	.7228	.7213	.7219	.7204	.7223	.7208	.7219	.7204
22	1.5	In.	.8261	.8250	.8267	.8256	.8270	.8259	.8273	.8263	.8279	.8269	.8273	.8263	.8267	.8256	.8270	.8259	.8267	.8256
22	2.5	In.	.7997	.7982	.8006	.7991	.8010	.7995	.8015	.8000	.8024	.8009	.8015	.8000	.8006	.7991	.8010	.7995	.8006	.7991
24	2	In.	.8916	.8903	.8923	.8910	.8927	.8914	.8931	.8918	.8939	.8926	.8931	.8918	.8923	.8910	.8927	.8914	.8923	.8910
24	3	In.	.8653	.8634	.8663	.8645	.8668	.8650	.8673	.8655	.8683	.8664	.8673	.8655	.8663	.8645	.8668	.8650	.8663	.8645
27	2	In.	1.0097	1.0084	1.0104	1.0091	1.0108	1.0095	1.0112	1.0099	1.012	1.0107	1.0112	1.0099	1.0104	1.0091	1.0208	1.0095	1.0104	1.0091
27	3	In.	.9835	.9816	.9845	.9827	.9850	.9832	.9855	.9837	.9866	.9847	.9855	.9837	.9845	.9827	.9850	.9832	.9845	.9827

Note: These dimensions are for set-up reference. Diameters must be finally established by actual rolling.

* Only Certain Grades Rollable

AXIAL Rolling Speeds

Blank Diameter Inches		Rolling Speed - FPM											Blank Diameter mm
		66	82	98	115	131	164	197	230	262	295	328	
		Rolling Speed - Meters/Minute											
		20	25	30	35	40	50	60	70	80	90	100	
		Component Rotating at ... RPM											
1/32	0.031	8000	10000	12000	14000	16000	20000	24000	28000	32000	36000	40000	1
5/64	0.078	3200	4000	4800	5600	6400	8000	9600	11200	12800	14400	16000	2
1/8	0.125	2000	2500	3000	3500	4000	5000	6000	7000	8000	9000	10000	3
5/32	0.156	1600	2000	2400	2800	3200	4000	4800	5600	6400	7200	8000	4
3/16	0.188	1300	1700	2000	2300	2700	3300	4000	4700	5300	6000	6700	5
1/4	0.250	1000	1300	1500	1800	2000	2500	3000	3500	4000	4500	5000	6
9/32	0.281	890	1100	1300	1600	1800	2200	2700	3100	3600	4000	4400	7
5/16	0.313	800	1000	1200	1400	1600	2000	2400	2800	3200	3600	4000	8
3/8	0.375	670	830	1000	1200	1300	1700	2000	2300	2700	3000	3300	9 - 10
7/16	0.438	570	710	860	1000	1100	1400	1700	2000	2300	2600	2900	11
1/2	0.500	500	630	750	880	1000	1300	1500	1800	2000	2300	2500	12 - 13
9/16	0.563	440	560	670	780	890	1100	1300	1600	1800	2000	2200	14
19/32	0.594	420	530	630	740	840	1100	1300	1500	1700	1900	2100	15
5/8	0.625	400	500	600	700	800	1000	1200	1400	1600	1800	2000	16 - 17
3/4	0.750	330	420	500	580	670	830	1000	1200	1300	1500	1700	18 - 19
13/16	0.813	310	380	460	540	620	770	920	1100	1200	1400	1500	20 - 21
7/8	0.875	290	360	430	500	570	710	860	1000	1100	1300	1400	22 - 23
15/16	0.938	270	330	400	470	530	670	800	930	1100	1200	1300	24
1	1.000	250	310	380	440	500	630	750	880	1000	1100	1300	25 - 27
1.1/8	1.125	220	280	330	390	440	560	670	780	890	1000	1100	28 - 29
1.3/16	1.188	210	260	320	370	420	530	630	740	840	950	1100	30 - 31
1.1/4	1.250	200	250	300	350	400	500	600	700	800	900	1000	32
1.5/16	1.313	190	240	290	330	380	480	570	670	760	860	1000	33
1.3/8	1.375	180	230	270	320	360	450	550	640	730	820	910	34 - 35
1.7/16	1.438	170	220	260	300	350	430	520	610	700	780	870	36 - 37
1.1/2	1.500	170	210	250	290	330	420	500	580	670	750	830	38 - 39
1.9/16	1.563	160	200	240	280	320	400	480	560	640	720	800	40 - 41
1.3/4	1.750	140	180	210	250	290	360	430	500	570	640	710	42 - 44
2	2.000	130	160	190	220	250	310	380	440	500	560	630	45 - 50

RADIAL Thread Rolling

RSVP Radial rolling heads offer an ideal solution for producing very short threads with tight runout, rolling close to a shoulder or into an undercut. Due to the 3-roll action of the radial system, the component is well supported during the rolling process, even when threading the ends of long shafts. Since the rolling action is completed within one revolution of the rolls, cycle times are extremely short and in most cases, under 0.5 seconds.

Radial rolling heads are automatically reset after each threading pass. They are actuated by external means when positioned over the component to be rolled by use of the external trip lever on stationary heads, or an internal push rod on rotating heads.

Radial Thread Rolling Operation	60
RE-8 - Overview & Components	61
RE-10 - Overview & Components	62
RE-13 - Overview & Components	63
RE-16 - Overview & Components	64
RE-23 - Overview & Components	65



RADIAL Thread Rolling Operation

Unlike the axial and tangential rolling systems, radial rolling does not require a controlled feed motion in order to produce a thread.

The RSVP RE style rolling head simply needs to be positioned over the part using the forward stroke of the machine. This may be a standard turret lathe, CNC machine or rotary transfer machine.

When the head is in position, the trip lever is actuated and the rolling process begins (fig. 2). The external trip can only be actuated when the head is stationary. For applications where the head is revolving, an internal trip must be actuated by a push rod mechanism through the shank (or flange) of the head.

The tripping of the head causes all 3 rolls to rotate under spring pressure until they contact the blank. At this point they pinch up against the part, and are driven round one full revolution. During this rotation of the rolls, their geometry effects a “squeezing down” in a radial direction and the thread is rapidly formed (fig. 3).

Once the rolls have completed the threading cycle, they are returned to the start position with their flats facing the threaded part. This allows the head to be retracted without damage to the thread. The head is now re-set and ready for the next cycle (fig. 4).

It is not advisable to trip the head without a blank in position as the rolls would not return to their start point. If a rolling pass is then attempted, the rolls will hit against the blank, damaging the rolls and possibly the head.

In automatic, un-manned cycles, it is advisable to operate some means of checking device, to ensure that the head is in the reset position before any attempt is made to roll a thread. The external trip lever can be actuated automatically or by

hand. For manual operation, a ball type handle can be attached to the trip lever which accepts an M5 x 0.8 thread. For automatic tripping, it is required that the external lever is brought up against a machine stop precisely at the point when the head reaches the desired rolling position. The head must not still be advancing forward after it is tripped.

Rotating direction of spindle

Most conventional spindles run in a right-hand, or clockwise direction, so RE radial heads and rolls are primarily supplied for this condition. These standard, right hand heads should not be solely associated with right hand threads. Right and left hand threads can be produced on the same head; it is only the roll design that alters.

The standard shank style heads illustrated in this publication can be mounted in most lathe turrets and used stationary, in which case the component & spindle rotate in the conventional right hand direction.

When used in rotating mode, RSVP radial heads can be shank or flange mounted. The heads must then be tripped by an internal push rod that passes through the back of the head. Actuation is normally by mechanical, hydraulic or pneumatic means.

Clamping of the component

The radial rolling action is completed in one revolution of the rolls which requires high momentary torque. This in turn imparts high loads on the part being rolled. It is imperative the work holding system is able to resist these high forces, and hydraulic clamping is usually preferred.

Blank preparation

Ensuring the blank diameter is correct is an essential ingredient for trouble free thread rolling. As with other rolling methods, the blank diameter is initially set at or just below the pitch diameter of the thread. Successive rolling passes will then determine the best blank size by trial and error. Threads rolled by the radial method should not exhibit smooth, fully formed crests as this indicates over-rolling which will shorten roll life.

Safety

Radial thread rolling combines high spindle speeds with extremely fast cycle times. Machinery should always be adequately guarded. If RSVP radial heads are to be fitted to manually operated lathes, then full eye protection should always be worn.

Figure: 2

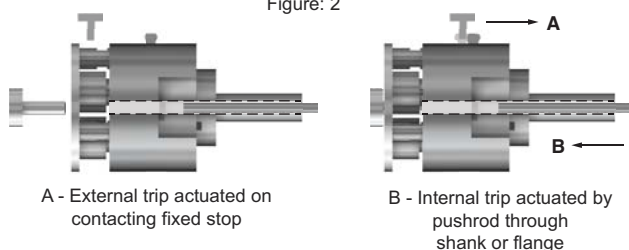

A - External trip actuated on contacting fixed stop

B - Internal trip actuated by pushrod through shank or flange

Figure: 3

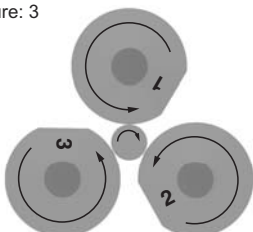
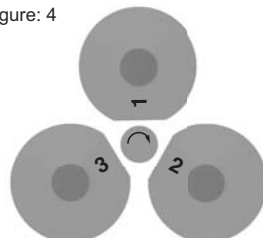

Figure: 4



RE-8 Radial Head

Radial Thread Rolling Heads
Standard Shank Style Illustrated
Flange Mounting Also Available

EDP	Shank	EDP	Shank	EDP	Shank
0800E	3/4"	0800E-1.25	1-1/4"	0800E-25	25mm
0800E-1	1"	0800E-20	20mm	0800E-30	30mm

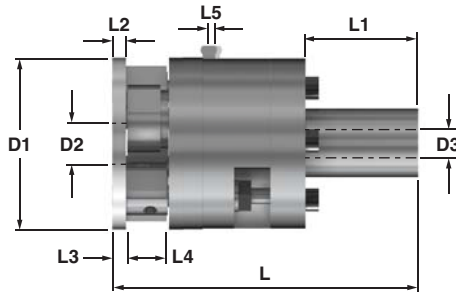

RE-8 Radial Head Dimensions

Dimensions

Shank Ø Options	D1	D2	D3	L	L1	
3/4 - 1 - 1-1/4	inches	2.520	0.591	0.413	4.551	1.575
20 - 25 - 30	mm	64	15.0	10.5	115.6	40.0

Dimensions Continued

Shank Ø Options	L2	L3	L4max	L5	
3/4 - 1 - 1-1/4	inches	0.197	0.205	0.457	0.087
20 - 25 - 30	mm	5	5.2	11.6	2.2

L4 = Maximum width of rolls
L5 = Stroke to trip head

The Following Thread Rolls May Be Ordered As Standard On The RE-8 Radial Head

1K EDP	ISO Metric Description
0803E	M3.5 x 0.5
0804E	M3.5 x 0.6
0805E	M4.0 x 0.7
0806E	M4.0 x 0.5
0807E	M5.0 x 0.8
0808E	M5.0 x 0.5
0809E	M6.0 x 1.0
0810E	M6.0 x 0.75
0811E	M6.0 x 0.5

1K EDP	ISO Metric (Continued) Description
0812E	M8.0 x 1.25
0813E	M8.0 x 1.0
0814E	M8.0 x 0.75
0815E	M8.0 x 0.5
0816E	M10.0 x 1.5
0817E	M10.0 x 1.25
0818E	M10.0 x 1.0
0819E	M10.0 x 0.75

1K EDP	Unified Fine UNF Description
0824E	5 x 40
0825E	5 x 44
0826E	6 x 32
0827E	6 x 40
0831E	8 x 32
0829E	8 x 36
0830E	10 x 24
0828E	10 x 32
0832E	12 x 24
0833E	12 x 28

1K EDP	Unified Fine UNF (Cont.) Description
0834E	1/4 x 20
0835E	1/4 x 28
0836E	1/4 x 32
0865E	5/16 x 18
0801E	5/16 x 24
0838E	5/16 x 32
0839E	3/8 x 16
0840E	3/8 x 24
0841E	3/8 x 32

1K EDP	National Pipe Thread NPT Description
0820E	1/16 x 27 NPT
0821E	1/8 x 27 NPT

National Pipe Thread Dryseal NPTF

1K EDP	Description
0822E	1/16 x 27 NPTF
0823E	1/8 x 27 NPTF

The range of sizes shown can normally be safely rolled on the RE-8 head. For thread forms other than those listed, please contact our technical department.

Thread rolls are supplied as standard to suit right hand heads. This refers to the direction of rotation of the spindle and not the thread itself. Both right and left hand threads can be rolled using the same head; only the rolls are changed.

Component Parts Breakdown

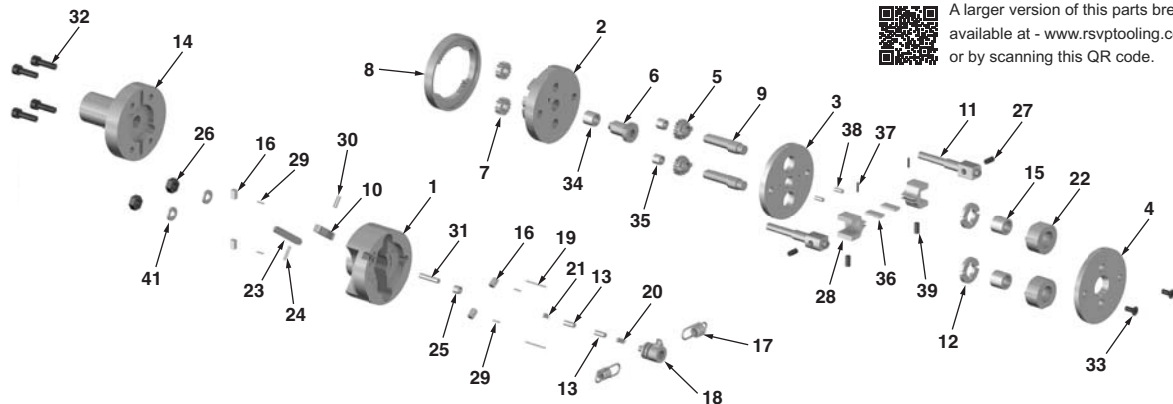

A larger version of this parts breakdown is available at - www.rsptooling.com/prints.html or by scanning this QR code.

Ref	Qty	Description	EDP
1	1	Spring Housing	08-001
2	1	Drive Gear Plate	08-002
3	1	Cover Plate	08-003
4	1	Front Plate	08-004
5	2	Synchronizing Gear w/Bushing	08-005
6	1	Center Gear	08-006
7	2	Adjusting Gear	08-007
8	1	Gear Rim	08-008
9	2	Eccentric Spindle	08-009
10	1	External Trip Release Lever	08-010
11	2	Spacer Pin	08-011
12	2	Drive Plate	08-012
13	2	Coupling Pin	08-013
14	1	Shank 3/4	08-014
14A	1	Shank 1"	08-014A

Ref	Qty	Description	EDP
14B	1	Shank 1-1/4	08-014B
14C	1	Shank 20mm	08-014C
14D	1	Shank 25mm	08-014D
14E	1	Shank 30mm	08-014E
15	2	Bushing	08-015
16	4	Fitting Key	08-016
17	1	Tension Spring (2 pcs.)	08-017
18	1	Clutch Stop	08-018
19	2	Pin	08-019
20	1	Pressure Spring, Heavy	08-020
21	1	Pressure Spring, Light	08-021
22	2	Thread Roll (see chart for size and EDP)	
23	1	Internal Trip Release Lever	08-023
24	1	Pin	08-024
25	1	Bushing	08-025

Ref	Qty	Description	EDP
26	2	Hex Nut	08-026
27	2	Set Screw	08-027
28	2	Guide with Carbide Blade	08-028
29	4	Stud	08-029
30	1	Pin	08-030
31	1	Pin	08-031
32	4	Cap Screw	08-032
33	2	Cap Screw	08-033
34	1	Bushing	08-034
35	2	Bushing - see Item 5	08-035
36	2	Carbide Blade - see Item 28	08-036
37	2	Pin	08-037
38	2	Pin	08-038
39	2	Set Screw	08-039
41	2	Washer	08-041

RE-10 Radial Head

Radial Thread Rolling Heads
Standard Shank Style Illustrated
Flange Mounting Also Available

EDP	Shank	EDP	Shank	EDP	Shank	EDP	Shank
1000E	3/4"	1000E-1.25	1-1/4"	1000E-20	20mm	1000E-30	30mm
1000E-1	1"	1000E-1.5	1-1/2"	1000E-25	25mm	1000E-32	32mm

RE-10 Radial Head Dimensions

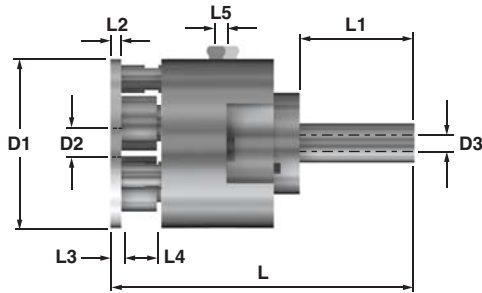

Dimensions

Shank Ø Options	D1	D2	D3	L	L1
3/4 - 1 - 1-1/4	inches	3.937	1.024	0.492	6.480
20 - 25 - 30 - 32	mm	100	26.0	12.5	164.6

Dimensions Continued

Shank Ø Options	L2	L3	L4max	L5
3/4 - 1 - 1-1/4	inches	0.236	0.244	0.772
20 - 25 - 30 - 32	mm	6	6.2	20

L4 = Maximum width of rolls

L5 = Stroke to trip head

The Following Thread Rolls May Be Ordered As Standard On The RE-10 Radial Head

ISO Metric	1K EDP	Description
M8.0 x 0.75	1003E	M8.0 x 0.75
M8.0 x 1.0	1004E	M8.0 x 1.0
M8.0 x 1.25	1005E	M8.0 x 1.25
M10.0 x 1.0	1006E	M10.0 x 1.0
M10.0 x 1.25	1007E	M10.0 x 1.25
M10.0 x 1.5	1008E	M10.0 x 1.5

ISO Metric (Continued)	1K EDP	Description
M12.0 x 1.0	1009E	M12.0 x 1.0
M12.0 x 1.25	1010E	M12.0 x 1.25
M12.0 x 1.5	1011E	M12.0 x 1.5
M14.0 x 1.25	1012E	M14.0 x 1.25
M14.0 x 1.5	1013E	M14.0 x 1.5
M14.0 x 1.0	1014E	M14.0 x 1.0

Unified Fine UNF	1K EDP	Description
5/16 x 20	1021E	5/16 x 20
5/16 x 24	1022E	5/16 x 24
5/16 x 32	1023E	5/16 x 32
3/8 x 16	1024E	3/8 x 16
3/8 x 24	1025E	3/8 x 24
3/8 x 32	1026E	3/8 x 32
7/16 x 20	1001E	7/16 x 20

Unified Fine UNF (Cont.)	1K EDP	Description
7/16 x 28	1027E	7/16 x 28
1/2 x 20	1028E	1/2 x 20
1/2 x 28	1029E	1/2 x 28
9/16 x 18	1002E	9/16 x 18
9/16 x 20	1030E	9/16 x 20
9/16 x 24	1031E	9/16 x 24

National Pipe Thread NPT	1K EDP	Description
1/16 x 27 NPT	1043E	1/16 x 27 NPT
1/8 x 27 NPT	1044E	1/8 x 27 NPT
1/4 x 18 NPT	1045E	1/4 x 18 NPT

National Pipe Thread Dryseal NPTF	1K EDP	Description
1/16 x 27 NPTF	1046E	1/16 x 27 NPTF
1/8 x 27 NPTF	1047E	1/8 x 27 NPTF
1/4 x 18 NPTF	1048E	1/4 x 18 NPTF

The range of sizes shown can normally be safely rolled on the RE-10 head. For thread forms other than those listed, please contact our technical department.

Thread rolls are supplied as standard to suit right hand heads. This refers to the direction of rotation of the spindle and not the thread itself. Both right and left hand threads can be rolled using the same head; only the rolls are changed.

Component Parts Breakdown

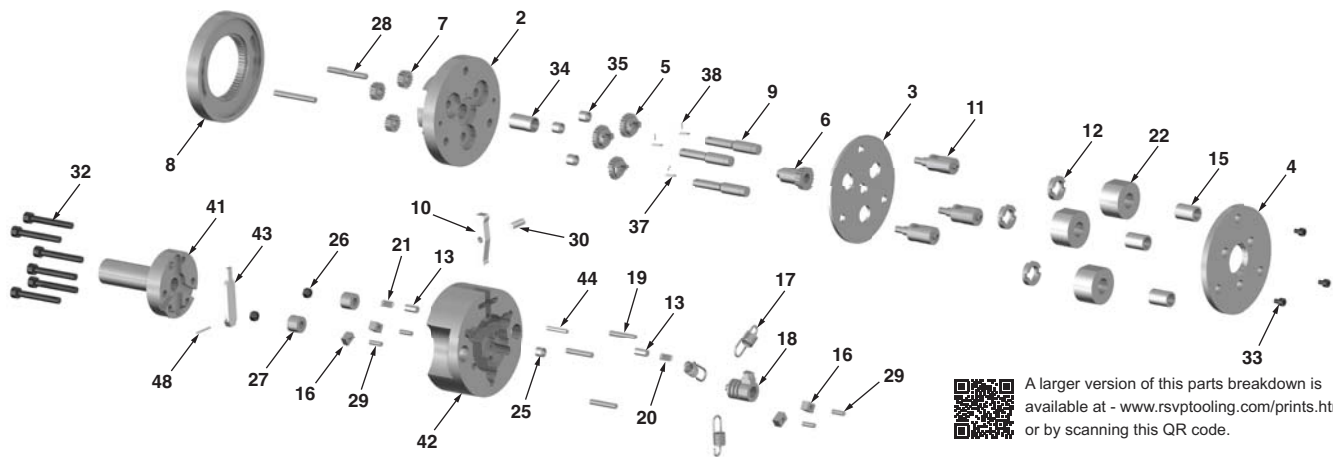

A larger version of this parts breakdown is available at www.rsvp tooling.com/prints.html or by scanning this QR code.

Ref	Qty	Description	EDP
2	1	Drive Gear Plate	10-002
3	1	Cover Plate	10-003
4	1	Front Plate	10-004
5	3	Synchronizing Gear w/Bushing	10-005
6	1	Center Gear	10-006
7	3	Adjusting Gear	10-007
8	1	Gear Rim	10-008
9	3	Eccentric Spindle	10-009
10	1	External Trip Release Lever	10-010
11	3	Spacer Pin	10-011
12	3	Drive Plate	10-012
13	2	Coupling Pin	10-013
15	3	Bushing	10-015
16	4	Fitting Key	10-016

Ref	Qty	Description	EDP
17	1	Tension Spring (3 pcs.)	10-017
18	1	Clutch Stop	10-018
19	3	Pin	10-019
20	1	Pressure Spring, Heavy	10-020
21	1	Pressure Spring, Light	10-021
22	3	Thread Roll (see chart for size and EDP)	10-025
25	1	Bushing	10-025
26	2	Hex Nut	10-026
27	2	Washer	10-027
28	2	Stud	10-028
29	4	Pin	10-029
30	1	Pin	10-030
32	6	Cap Screw	10-032
33	3	Cap Screw	10-033

Ref	Qty	Description	EDP
34	1	Bushing	10-034
35	3	Bushing - see Item 5	10-035
37	3	Fitting Key	10-037
38	3	Pin	10-038
41	1	Shank 3/4	10-041
41A	1	Shank 1"	10-041A
41B	1	Shank 1-1/4	10-041B
41C	1	Shank 20mm	10-041C
41D	1	Shank 25mm	10-041D
41E	1	Shank 30mm	10-041E
41F	1	Shank 32mm	10-041F
42	1	Spring Housing	10-042
43	1	Internal Trip Release Lever	10-043
44	1	Pin	10-044
48	1	Pin	10-048

RE-13 Radial Head

Radial Thread Rolling Heads
Standard Shank Style Illustrated
Flange Mounting Also Available

EDP	Shank	EDP	Shank
1300E	1-1/2"	1300E-30	30mm
1300E-1.25	1-1/4"	1300E-40	40mm

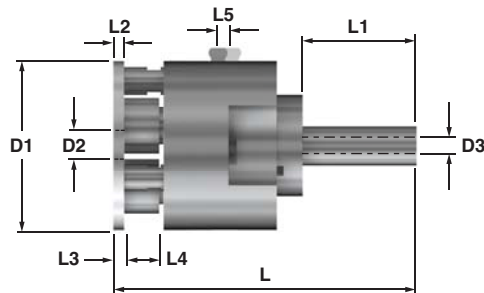

RE-13 Radial Head Dimensions

Dimensions

Shank Ø Options	D1	D2	D3	L	L1
1-1/4 - 1-1/2 inches	4.921	1.260	0.492	7.622	3.150
30 - 40 mm	125	32.0	12.5	193.6	80.0

Dimensions Continued

Shank Ø Options	L2	L3	L4max	L5
1-1/4 - 1-1/2 inches	0.315	0.323	0.968	0.118
30 - 40 mm	8	8.2	24.6	3

L4 = Maximum width of rolls
L5 = Stroke to trip head

The Following Thread Rolls May Be Ordered As Standard On The RE-13 Radial Head

ISO Metric	
1K EDP	Description
1303E	M10.0 x 0.75
1304E	M10.0 x 1.0
1305E	M10.0 x 1.25
1306E	M10.0 x 1.5
1307E	M12.0 x 1.0
1308E	M12.0 x 1.25
1309E	M12.0 x 1.5
1310E	M12.0 x 1.75

ISO Metric (Continued)	
1K EDP	Description
1311E	M14.0 x 1.0
1312E	M14.0 x 1.25
1323E	M14.0 x 1.5
1314E	M16.0 x 1.0
1315E	M16.0 x 1.5
1316E	M18.0 x 1.0
1317E	M18.0 x 1.5

Unified Fine UNF	
1K EDP	Description
1326E	7/16 x 14
1301E	7/16 x 20
1328E	7/16 x 28
1329E	1/2 x 13
1330E	1/2 x 20
1331E	1/2 x 28

Unified Fine UNF (Cont.)	
1K EDP	Description
1332E	9/16 x 18
1333E	9/16 x 20
1334E	9/16 x 24
1335E	5/8 x 18
1336E	5/8 x 24
1337E	11/16 x 24

National Pipe Thread NPT	
1K EDP	Description
1350E	1/8 x 27 NPT
1302E	1/4 x 18 NPT
1352E	3/8 x 18 NPT

National Pipe Thread Dryseal NPTF	
1K EDP	Description
1353E	1/8 x 27 NPTF
1354E	1/4 x 18 NPTF
1355E	3/8 x 18 NPTF

The range of sizes shown can normally be safely rolled on the RE-13 head. For thread forms other than those listed, please contact our technical department.

Thread rolls are supplied as standard to suit right hand heads. This refers to the direction of rotation of the spindle and not the thread itself. Both right and left hand threads can be rolled using the same head; only the rolls are changed.

Component Parts Breakdown

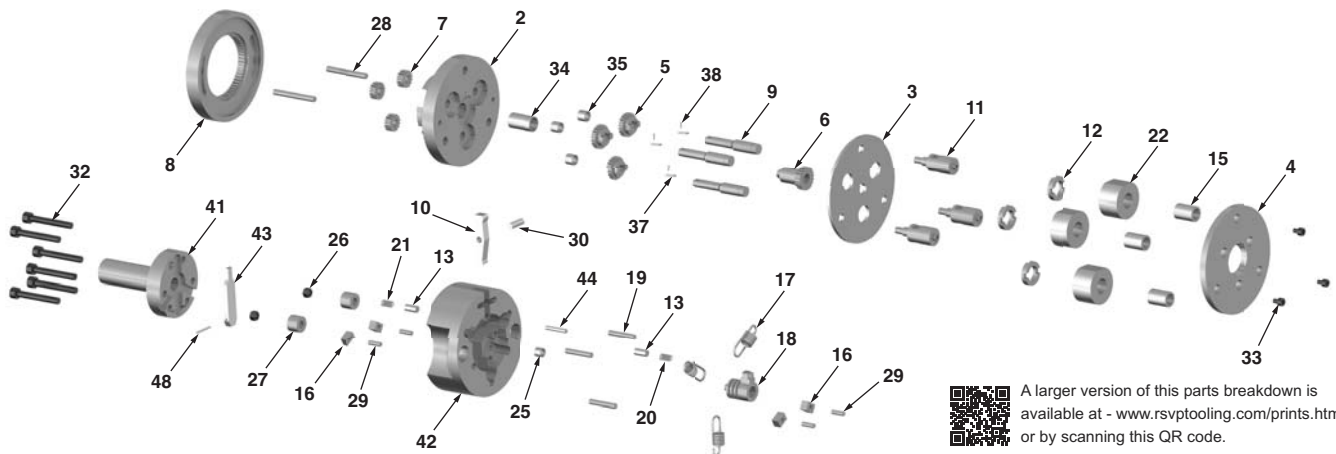

A larger version of this parts breakdown is available at - www.rsviewport.com/prints.html or by scanning this QR code.

Ref	Qty	Description	EDP
2	1	Drive Gear Plate	13-002
3	1	Cover Plate	13-003
4	1	Front Plate	13-004
5	3	Synchronizing Gear w/Bushing	13-005
6	1	Center Gear	13-006
7	3	Adjusting Gear	13-007
8	1	Gear Rim	13-008
9	3	Eccentric Spindle	13-009
10	1	External Trip Release Lever	13-010
11	3	Spacer Pin	13-011
12	3	Drive Plate	13-012
13	2	Coupling Pin	10-013
15	3	Bushing	13-015

Ref	Qty	Description	EDP
16	4	Fitting Key	10-016
17	1	Tension Spring (3 pcs.)	13-017
18	1	Clutch Stop	13-018
19	3	Pin	10-019
20	1	Pressure Spring, Heavy	13-020
21	1	Pressure Spring, Light	13-021
22	3	Thread Roll (see chart for size and EDP)	
25	1	Bushing	10-025
26	2	Hex Nut	10-026
27	2	Washer	13-027
28	2	Stud	13-028
29	4	Pin	10-029
30	1	Pin	10-030

Ref	Qty	Description	EDP
32	6	Cap Screw	10-032
33	3	Cap Screw	13-033
34	1	Bushing	13-034
35	3	Bushing - see Item 5	13-035
37	3	Fitting Key	13-037
38	3	Pin	13-038
41	1	Shank 1-1/2	13-041
41A	1	Shank 1-1/4	13-041A
41B	1	Shank 30mm	13-041B
41C	1	Shank 40mm	13-041C
42	1	Spring Housing	13-042
43	1	Internal Trip Release Lever	13-043
44	1	Pin	10-044
48	1	Pin	13-048

RE-16 Radial Head

Radial Thread Rolling Heads
Standard Shank Style Illustrated
Flange Mounting Also Available

EDP	Shank	EDP	Shank
1600E	1-1/2"	1600E-40	40mm
1600E-2	2"	1600E-50	50mm

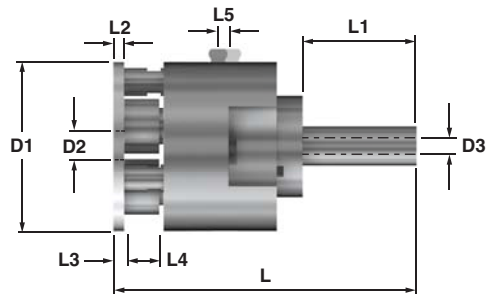

RE-16 Radial Head Dimensions

Dimensions

Shank Ø Options		D1	D2	D3	L	L1
1-1/2 - 2	inches	5.512	1.594	0.492	8.366	3.150
40 - 50	mm	140	40.5	12.5	212.5	80.0

Dimensions Continued

Shank Ø Options		L2	L3	L4max	L5
1-1/2 - 2	inches	0.394	0.402	1.165	0.173
40 - 50	mm	10	10.2	29.6	4.4

L4 = Maximum width of rolls
L5 = Stroke to trip head

The Following Thread Rolls May Be Ordered As Standard On The RE-16 Radial Head

1K EDP	ISO Metric Description
1602E	M12.0 x 1.0
1603E	M12.0 x 1.25
1604E	M12.0 x 1.5
1605E	M12.0 x 1.75
1606E	M14.0 x 1.0
1607E	M14.0 x 1.25
1608E	M14.0 x 1.5
1610E	M14.0 x 2.0
1650E	M16.0 x 1.0
1614E	M16.0 x 1.5

1K EDP	ISO Metric (Continued) Description
1651E	M16.0 x 2.0
1652E	M18.0 x 1.0
1617E	M18.0 x 1.5
1618E	M18.0 x 2.0
1619E	M20.0 x 1.0
1620E	M20.0 x 1.5
1621E	M20.0 x 2.0
1622E	M22.0 x 1.0
1623E	M22.0 x 1.5
1624E	M22.0 x 2.0

1K EDP	Unified Fine UNF Description
1669E	7/16 x 20
1633E	1/2 x 13
1634E	1/2 x 20
1635E	1/2 x 28
1636E	9/16 x 12
1637E	9/16 x 18
1638E	9/16 x 20
1639E	9/16 x 24
1640E	5/8 x 11

1K EDP	Unified Fine UNF (Cont.) Description
1641E	5/8 x 18
1642E	5/8 x 24
1643E	11/16 x 24
1644E	3/4 x 16
1645E	3/4 x 20
1665E	13/16 x 20
1646E	7/8 x 14
1647E	7/8 x 20

1K EDP	National Pipe Thread NPT Description
1662E	1/4 x 18 NPT
1663E	3/8 x 18 NPT
1601E	1/2 x 14 NPT

1K EDP	National Pipe Thread Dryseal NPTF Description
1660E	1/4 x 18 NPTF
1661E	3/8 x 18 NPTF
1664E	1/2 x 14 NPTF

The range of sizes shown can normally be safely rolled on the RE-16 head. For thread forms other than those listed, please contact our technical department.

Thread rolls are supplied as standard to suit right hand heads. This refers to the direction of rotation of the spindle and not the thread itself. Both right and left hand threads can be rolled using the same head; only the rolls are changed.

Component Parts Breakdown

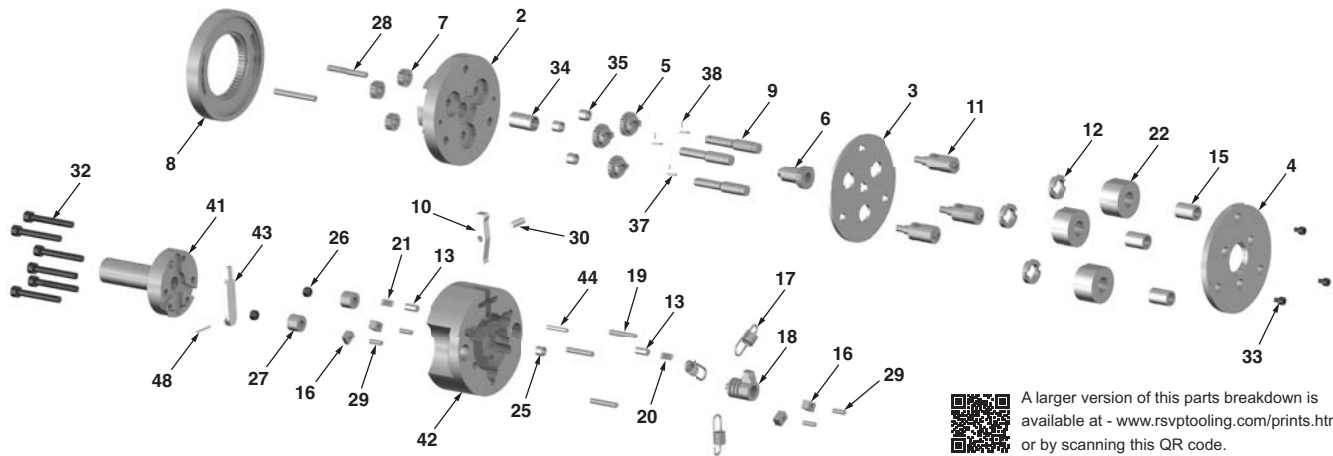

A larger version of this parts breakdown is available at - www.rsvptooling.com/prints.html or by scanning this QR code.

Ref	Qty	Description	EDP
2	1	Drive Gear Plate	16-002
3	1	Cover Plate	16-003
4	1	Front Plate	16-004
5	3	Synchronizing Gear w/Bushing	16-005
6	1	Center Gear	16-006
7	3	Adjusting Gear	16-007
8	1	Gear Rim	16-008
9	3	Eccentric Spindle	16-009
10	1	External Trip Release Lever	16-010
11	3	Spacer Pin	16-011
12	3	Drive Plate	16-012
13	2	Coupling Pin	16-013
15	3	Bushing	16-015

Ref	Qty	Description	EDP
16	4	Fitting Key	16-016
17	1	Tension Spring (3 pcs.)	16-017
18	1	Clutch Stop	16-018
19	3	Pin	16-019
20	1	Pressure Spring, Heavy	16-020
21	1	Pressure Spring, Light	16-021
22	3	Thread Roll (see chart for size and EDP)	
25	1	Bushing	16-025
26	2	Hex Nut	16-026
27	2	Washer	16-027
28	2	Stud	16-028
29	4	Pin	10-029
30	1	Pin	16-030

Ref	Qty	Description	EDP
32	6	Cap Screw	16-032
33	3	Cap Screw	16-033
34	1	Bushing	16-034
35	3	Bushing - see Item 5	16-035
37	3	Fitting Key	16-037
38	3	Pin	16-038
41	1	Shank 1-1/2	16-041
41A	1	Shank 2"	16-041A
41B	1	Shank 40mm	16-041B
41C	1	Shank 50mm	16-041C
42	1	Spring Housing	16-042
43	1	Internal Trip Release Lever	16-043
44	1	Pin	16-044
48	1	Pin	13-048

RE-23 Radial Head

Radial Thread Rolling Heads
Standard Shank Style Illustrated
Flange Mounting Also Available

EDP	Shank	EDP	Shank
2300E	2"	2300E-50	50mm
2300E-2.5	2-1/2"	2300E-60	60mm

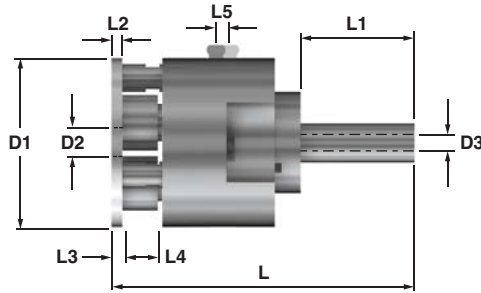

Dimensions

Shank Ø Options		D1	D2	D3	L	L1
2 - 2-1/2	inches	6.693	1.968	0.492	10.295	3.937
50 - 60	mm	170	50.0	12.5	261.5	100.0

Dimensions Continued

Shank Ø Options		L2	L3	L4max	L5
2 - 2-1/2	inches	0.512	0.520	1.362	0.177
50 - 60	mm	13	13.2	34.6	4.5

L4 = Maximum width of rolls
L5 = Stroke to trip head

The Following Thread Rolls May Be Ordered As Standard On The RE-23 Radial Head

ISO Metric	
1K EDP	Description
2301E	M16.0 x 1.0
2302E	M16.0 x 1.5
2303E	M16.0 x 2.0
2304E	M18.0 x 1.0
2305E	M18.0 x 1.25
2306E	M18.0 x 1.5
2307E	M18.0 x 2.0
2308E	M18.0 x 2.5
2309E	M20.0 x 1.0
2310E	M20.0 x 1.5
2311E	M20.0 x 2.0
2312E	M20.0 x 2.5
2313E	M22.0 x 1.0

ISO Metric (Continued)	
1K EDP	Description
2314E	M22.0 x 1.5
2315E	M22.0 x 2.0
2316E	M22.0 x 2.5
2317E	M24.0 x 1.0
2318E	M24.0 x 1.5
2319E	M24.0 x 2.0
2320E	M26.0 x 1.5
2321E	M27.0 x 1.5
2322E	M27.0 x 2.0
2323E	M28.0 x 1.5
2324E	M30.0 x 1.5
2325E	M30.0 x 2.0

Unified Fine UNF	
1K EDP	Description
2334E	5/8 x 11
2335E	5/8 x 18
2336E	5/8 x 24
2337E	11/16 x 24
2338E	3/4 x 10
2339E	3/4 x 16
2340E	3/4 x 20
2341E	13/16 x 20
2370E	7/8 x 14

Unified Fine UNF (Cont.)	
1K EDP	Description
2369E	7/8 x 20
2344E	15/16 x 20
2345E	1 x 12
2871E	1 x 20
2347E	1-1/16 x 18
2348E	1-1/8 x 12
2349E	1-1/8 x 18
2350E	1-3/16 x 18

National Pipe Thread NPT	
1K EDP	Description
2363E	3/8 x 18 NPT
2364E	1/2 x 14 NPT
2365E	3/4 x 14 NPT

National Pipe Thread Dryseal NPTF	
1K EDP	Description
2366E	3/8 x 18 NPTF
2367E	1/2 x 14 NPTF
2368E	3/4 x 14 NPTF

Thread rolls are supplied as standard to suit right hand heads. This refers to the direction of rotation of the spindle and not the thread itself. Both right and left hand threads can be rolled using the same head; only the rolls are changed.

The range of sizes shown can normally be safely rolled on the RE-23 head. For thread forms other than those listed, please contact our technical department.

Component Parts Breakdown

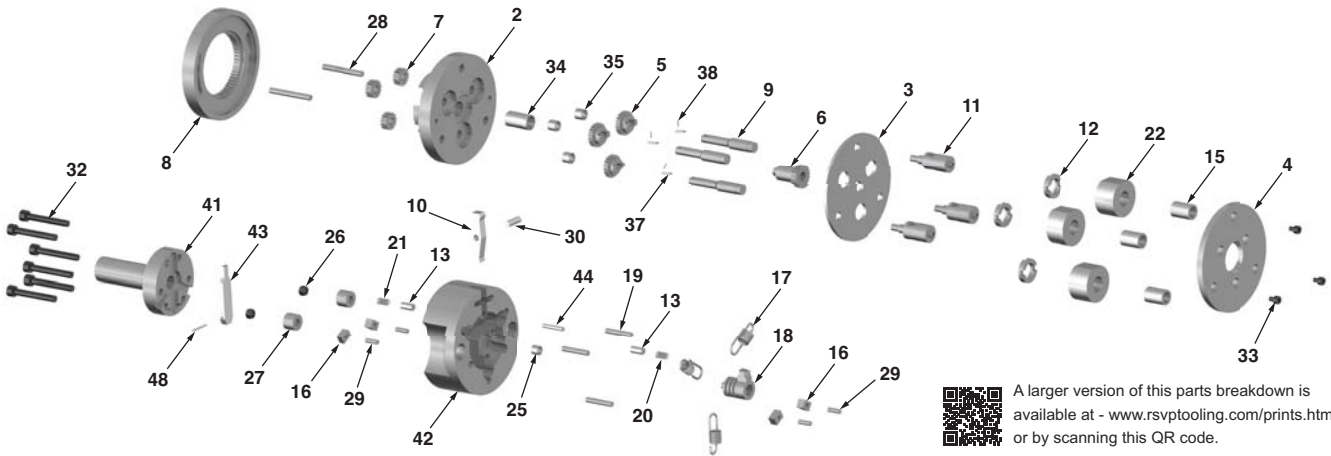

A larger version of this parts breakdown is available at - www.rsvptooling.com/prints.html or by scanning this QR code.

Ref	Qty	Description	EDP
2	1	Drive Gear Plate	23-002
3	1	Cover Plate	23-003
4	1	Front Plate	23-004
5	3	Synchronizing Gear w/Bushing	23-005
6	1	Center Gear	23-006
7	3	Adjusting Gear	23-007
8	1	Gear Rim	23-008
9	3	Eccentric Spindle	23-009
10	1	External Trip Release Lever	23-010
11	3	Spacer Pin	23-011
12	3	Drive Plate	23-012
13	2	Coupling Pin	23-013
15	3	Bushing	23-015

Ref	Qty	Description	EDP
16	4	Fitting Key	23-016
17	1	Tension Spring (3 pcs.)	23-017
18	1	Clutch Stop	23-018
19	3	Pin	23-019
20	1	Pressure Spring, Heavy	23-020
21	1	Pressure Spring, Light	23-021
22	3	Thread Roll (see chart for size and EDP)	
25	1	Bushing	16-025
26	2	Hex Nut	16-026
27	2	Washer	16-027
28	2	Stud	23-028
29	4	Pin	10-029
30	1	Pin	23-030

Ref	Qty	Description	EDP
32	6	Cap Screw	23-032
33	3	Cap Screw	23-033
34	1	Bushing	23-034
35	3	Bushing - see Item 5	23-035
37	3	Fitting Key	23-037
38	3	Pin	23-038
41	1	Shank 1-1/2	23-041
41A	1	Shank 2"	23-041A
41B	1	Shank 40mm	23-041B
41C	1	Shank 50mm	23-041C
42	1	Spring Housing	23-042
43	1	Internal Trip Release Lever	23-043
44	1	Pin	23-044
48	1	Pin	13-048

TANGENTIAL Thread Rolling System

Our RT Tangential system is interchangeable with the Fette style tangential thread rolling system. They will fit into your existing machine tool holders and take the same rolls you are currently using:

RT10 = T12 RT20 = T18 RT30 = T27

By using lathe type machine tools with automatic, power infeed as with controlled or hydraulic automatics, hydraulically operated copy lathe, NC/CNC lathes, etc., it is now possible to feed from the side of the part and obtain all of the advantages of the rolling method. RSVP tangential type rolling attachments are especially suited to produce the following threads and profiles:

- Thread rolled behind a shoulder
- Extremely short thread lengths
- Threads with a very short runout (approx. 1/2 - 1 x pitch)
- Tapered threads
- Straight knurls DIN 82
- Burnishing
- Forming

The component must rotate for this application. RSVP tangential side rolling attachments are available in 3 sizes covering a wide range of diameters. It is recommended that the largest rolling attachment that can be adapted on the machine always be used, thereby offering the advantage that the entire work range of the machine can be utilized. Longer threads, maximum component shoulder diameters, and a higher efficiency of the rolling attachment will be attained that way.

Attachments.....	67
Thread Rolls & Setting Gauges.....	68
Design of Rolls.....	69
RT10 - Overview & Components.....	70
RT20 - Overview & Components.....	71
RT30 - Overview & Components.....	72
Tangential Thread Roll Charts.....	73
Custom Tangential Thread Rolls.....	74



TANGENTIAL Side Thread Rolling Attachments, Type RT 10, RT 20 & RT 30

RSVP tangential side rolling attachments were originally developed to roll threads behind a shoulder. The process requires the rolls to be plunged, at a controlled rate, into the rotating component. Tangential side rolling attachments may be mounted in any machine tool having a cross slide or turret with a controlled feed stroke. The attachment is mounted in a holder that has been designed for a specific machine tool. There must be clearance between the attachment and machine tool, as well as between the arms of the attachment and any shoulder on the component.

For left-hand threads, the same attachment can be used as for right-hand threads. Left-hand threads require left-hand rolls.

RSVP - Tangential side rolling attachments, Type RT, have a capacity range to 64 mm / 2.52".

Capacity ranges are shown in the adjoining table.

The thread length including thread runout can not exceed the width of the roll. For shorter threads, rolls can be supplied with a recess for additional clearance. Roll width must be specified.

Also attachments with smaller construction numbers are suitable in the same work range, there are exceptions.



Tangential Head Adapter



Fig. 1: Tangential Side Thread Rolling Attachments, Type RT

Capacity Range

Cylindrical Threads					
Type		Major Diameter	min.	max.	Roll
		min.	max.	Pitch width TPI	max. ¹⁾
RT10	mm	1.6	14	1.5	15.5
up to work No. 66	inch	1/6	9/16	16	0.6102
RT20	mm	2	30	2	21.5
up to work No. 548	inch	5/64	1 3/16	12	0.8465
RT30	mm	2	42	2.5	31
up to work No. 467	inch	5/64	1 5/8	10	1.2205

Tapered Threads					
Type	Standard	min.	max.		
RT10 Up to work No 66	DIN 158	M 6 x 1 taper	M 14 x 1.5 taper		
	DIN 2999	G 1/16 - 28	G 1/4 - 19		
	DIN 3858	G 1/8 - 28	G 1/4 - 19		
	ANSI B1.20.1	1/16-27NPT(NPTF)	1/4-18NPT(NPTF)		
RT20 up to work No 548	DIN 158	M 6 x 1 taper	M 30 x 1.5 taper		
	DIN 2999	G 1/16 - 28	G 3/4 - 14		
	DIN 3858	G 1/8 - 28	G 3/4 - 14		
	ANSI B1.20.1	1/16-27NPT(NPTF)	1/2-14NPT(NPTF)		
RT30 up to work No. 467	DIN 158	M 6 x 1 taper	M 42 x 2 taper		
	DIN 2999	G 1/16 - 28	G 1 1/4 - 11		
	DIN 3858	G 1/8 - 28	G 1 1/4 - 11		
	ANSI B 1.20.1	1/6 - 27 NPT (NPTF)	1 - 11.5 NPT (NPTF)		

Tolerances for Shoulder dia. and cam rise.

With metric (DIN 458) and Whitworth (DIN 2999, DIN 3858) profiles the shoulder dia. and cam rise with cylindrical threads are dimensionally identical, NPT - and NPTF (ANSI B 1.20.1) threads.

TANGENTIAL Thread Rolls & Setting Gauges

Thread rolls

One set of rolls is needed for each thread size. One set has two different rolls. They are marked with the number 1 and 2. The rolls have a defined position on the rolling attachment. The rolling attachments are marked on the front end, with the number 1 on the upper side and number 2 on the lower side. The roll number 1 has to be mounted where the number 1 is marked on the attachment. It is imperative that the roll is mounted with the marked number looking towards the outside of the attachment. The same has to be done with roll number 2. Both marked numbers have to look to the outer side of the attachment.

Spindle direction may be right or left handed the component must rotate in the same direction of the arrow on the roll that contacts the component first.

The marking in the roll consists of the thread size, attachment size, code number, roll width, roll style and EDP number.

Setting Gauges

There is a setting gauge for each thread size. The setting gauge has to tasks:

1. The distance of the axles are set-up after mounting the rolls on the attachment. In general the width of the recessed part of the gauge is equivalent to the core diameter of the thread. This dimension has to be setup tight between the rolls.

Please check when using the setting gauge that the marking of attachment size and serial code number are identical to the marking of attachment size and serial code number on the rolls.

2. The size of the stroke is set. The attachment holder is mounted on the slide (turret). The gauge is mounted on the pin of the attachment holder. The slide has to be advanced towards the component direction, until the tip of the gauge touches the blank diameter. This position is the end of the work stroke.

Roll-Key-Code:

(Example for M 22 x 2.5 on attachment Type RT30)

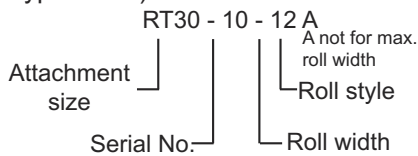

Max. width rolls
 T 12 = 15.5 mm/0.61"
 T 18 = 21.5 mm/0.846"
 T 27 = 31 mm/1.22"
 T 42 = 40.5 mm/1.594"

Setting Gauges-Key-Code:

(Example for M 22 x 2.5 on attachment Type RT30)

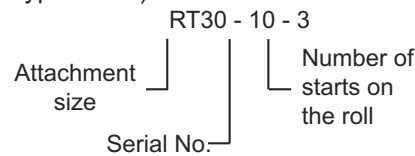

Please check when using the setting gauge, that the marking of attachment size and serial code number are identical to the marking of attachment size and serial code no. on the rolls.

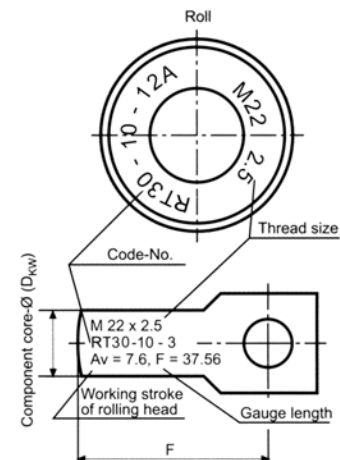

Standard roll width design

Head	Roll Widths (mm)/inch													
	4	6	8	10	12	14	15.5							
RT10	0.157	0.236	0.315	0.394	0.472	0.551	0.61							
RT20	-	6	8	10	12	14	16	18	21.5					
	-	0.236	0.315	0.394	0.472	0.551	0.63	0.709	21.5					
RT30	-	-	8	10	12	14	16	18	20	22	24	26	28	31
	-	-	0.315	0.394	0.472	0.551	0.63	0.709	0.787	0.866	0.945	1.024	1.102	1.22

It is recommended to order the roll widths in the dimensions shown. Special requirements upon request.

TANGENTIAL Design Of Rolls

Depending on the type of component, rolls of various design configurations can be used (normally design "A" is used). The maximum roll runout on each side can be about 1 x pitch, or in the case of multiple start threads about 1 x lead. The width of rolls must therefore be at least 2 x pitch longer than the effective thread length on the component.

If the roll width is unimportant (Example: journal portion in front, or in front of a shoulder diameter) it would be advisable to indicate the minimum and the maximum width of the roll, as it would facilitate delivery from stock. The tangential side rolling attachment can also be used with its wide arm side pointing towards the spindle.

One set of rolls and one setting gauge are required for every size of thread to be rolled. The first two number groups need to be the same.

Example of roll width and styles for tapered & parallel type threads

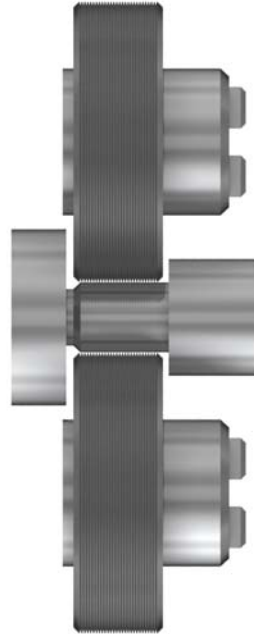

Parallel Rolls - Type A

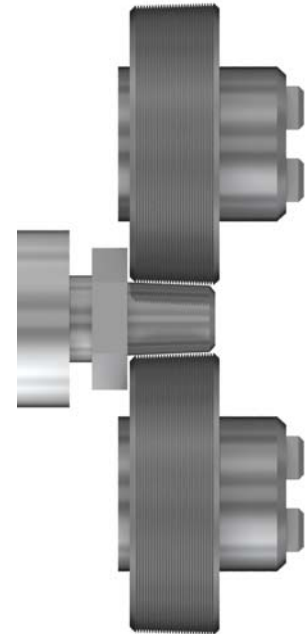

Taper Rolls - Type AV

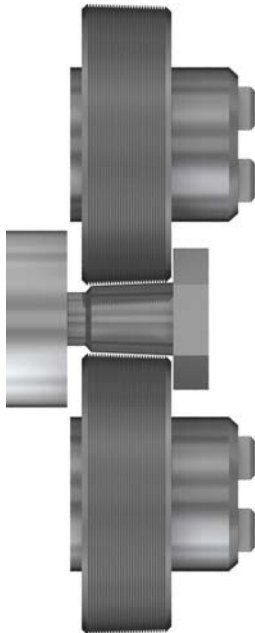

Taper Rolls - Type A

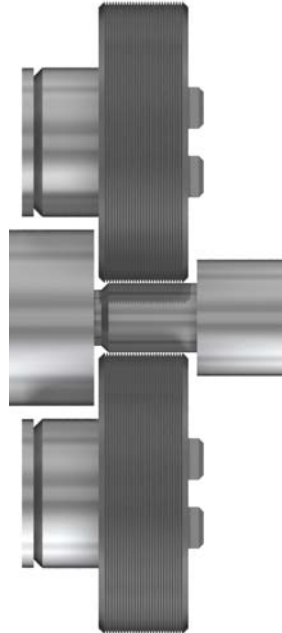

Parallel Rolls - Type B

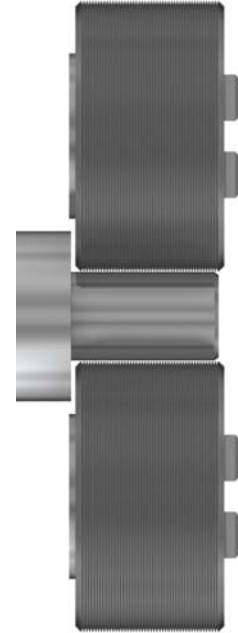

Parallel Rolls - Type F

RT-10 Tangential Side Thread Rolling Attachment

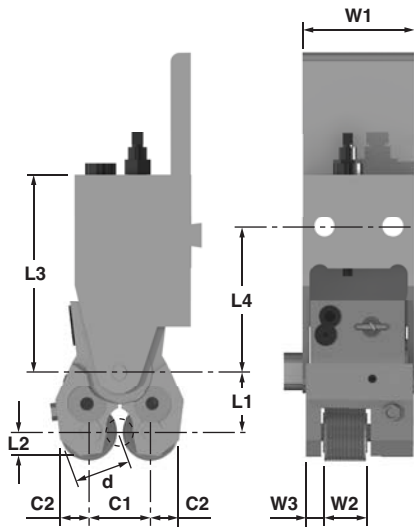

Dmax = max. shoulder diameter
 Av = Operating feed
 Dimensions above refer to cross slide mounted holder.
 Dimensions for other tool holder are adapted to the respective machine.

Roiling Attachment		RT10
W1 mm/inch		43 / 1.693
W2 mm/inch		15.5 / 0.61
W3 mm/inch		7.2 / 0.283
L1 mm/ Inch min./max.		23.2 / 0.913 27.6 / 1.087
L2 mm/inch		10 / 0.394
L3 mm/inch		80 / 3.15
C1 mm/inch min./max.		26.5 / 1.043 40 / 1.575
C2 mm/inch		14/0.551
d mm/inch max.		31.5 / 1.24
L4		70 / 2.756
Weight Approx. (kg)	Rolling Attachment	0.65
	Rolling Attachment Holder	0.75
	Thread rolls (1 set = 2 pieces)	0.17
	Setting gauge	0.05
	Total	1.62

For left hand threads, the same rolling attachment can be used as for right hand threads. Left hand threads require left hand rolls.

Component Parts Breakdown

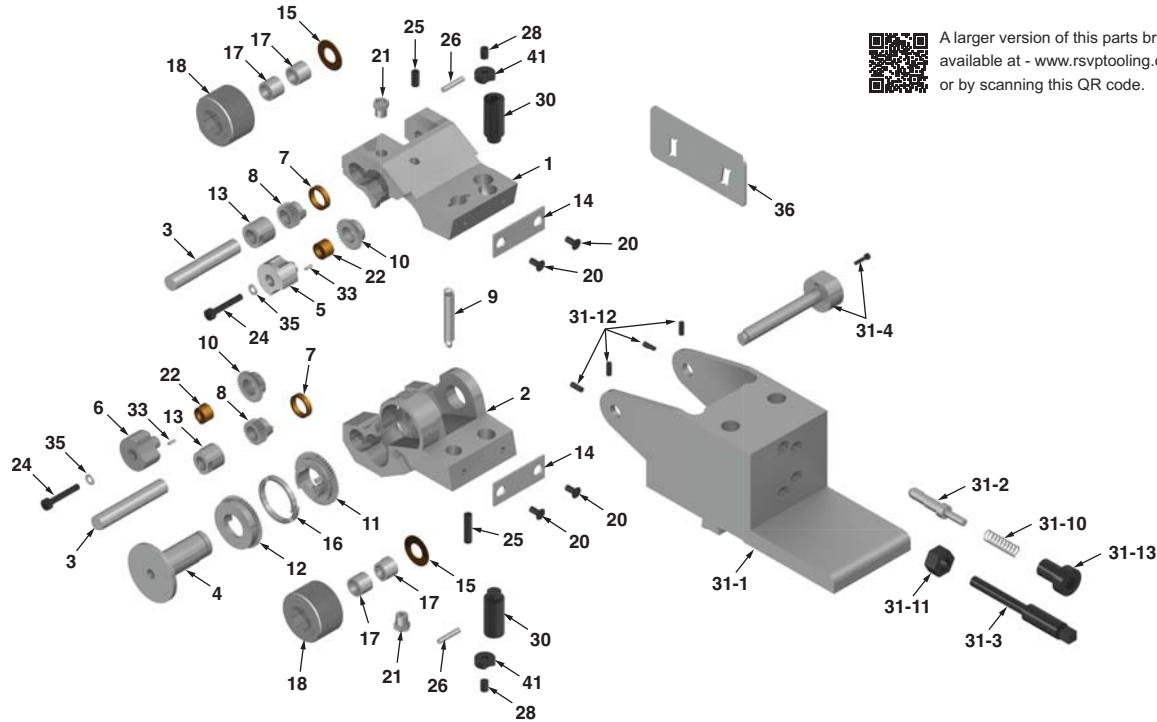

A larger version of this parts breakdown is available at - www.rsvptooling.com/prints.html or by scanning this QR code.

Item #	EDP	Description	Qty
1	10-001	Upper Arm	1**
2	10-002	Lower Arm	1
3	10-003	Shaft	2
4	10-004	Center Shaft	1
5	10-005	Bushing	1
6	10-006	Bushing	1
7	10-007	Bearing Bushing	2
8	10-008	Pinion	2
9	10-009	Tension Spring	1
10	10-010	Gear w/Bushing	2
11	10-011	Gear (assy w/12 & 16 only)	0**
12	10-012	Gear w/Coil Spring	1
13	10-013	Carbide Bushing	2
14	10-014	Plate	2

Item #	EDP	Description	Qty
15	10-015	Thrust Washer	2
16	10-016	Coil spring (assy w/11 & 12)	1
17	10-017	Bushing	4
20	10-020	Flat Head Scr.	4
21	10-021	Grease Nipple	2
22	10-022	Bearing Bushing	2
24	10-024	Cap Screw	2
25	10-025	Cap Screw	2
26	10-026	Straight Pin	2
27	10-027	Set Screw	1
28	10-028	Set Screw	2
30	10-030	Adj. Set Screw	2
31	10-031	Attachment Holder Complete	1*
31-1	10-031-1	Housing	1*

Item #	EDP	Description	Qty
31-2	10-031-2	Spring Loded Bolt	1
31-3	10-031-3	Stop Bolt	1
31-4A	10-031-4A	Bolt	1
31-4B	10-031-4B	Bolt	1
31-10	10-031-10	Thrust Spring	1
31-11	10-031-11	Hex Nut	1
31-12	10-031-12	Set Screw	2
31-13	10-031-13	Cap Screw	1
32	10-032	Setting Gauge	1*
33	10-033	Slotted Pin	2
35	10-035	Schnorr Clip	2
36	10-036	Sheet Metal Gauge	1
41	10-041	Lock Washer	2

Sold as an assembly only
 *(#1 & #2 Arm Assy) (#11, 12 & 16 gear w/Coil Spring Assy)
 †Per Application

RT-20 Tangential Side Thread Rolling Attachment

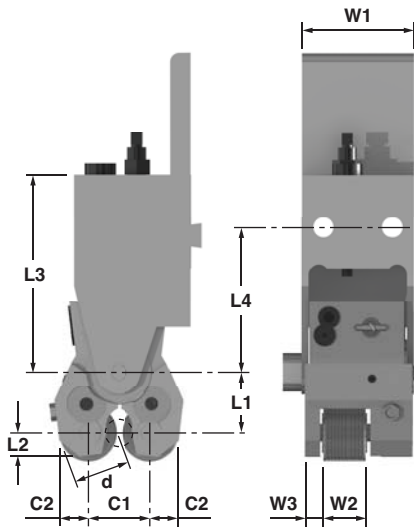

Dmax = max. shoulder diameter
 Av = Operating feed
 Dimensions above refer to cross slide mounted holder.
 Dimensions for other tool holder are adapted to the respective machine.

Roiling Attachment		RT20
W1 mm/inch		58 / 2.283
W2 mm/inch		21.5 / 0.846
W3 mm/inch		11.1 / 0.437
L1 mm/ Inch min./max.		30.1 / 1.185 37.8 / 1.488
L2 mm/inch		14 / 0.551
L3 mm/inch		100 / 3.937
C1 mm/inch min./max.		40.5 / 1.594 61 / 2.402
C2 mm/inch		19.8/0.78
d mm/inch max.		44 / 1.732
L4		97.5 / 3.839
Weight Approx. (kg)	Rolling Attachment	1.7
	Roiling Attachment Holder	2.4
	Thread rolls (1 set = 2 pieces)	0.45
	Setting gauge	0.1
	Total	4.65

For left hand threads, the same rolling attachment can be used as for right hand threads. Left hand threads require left hand rolls.

Component Parts Breakdown

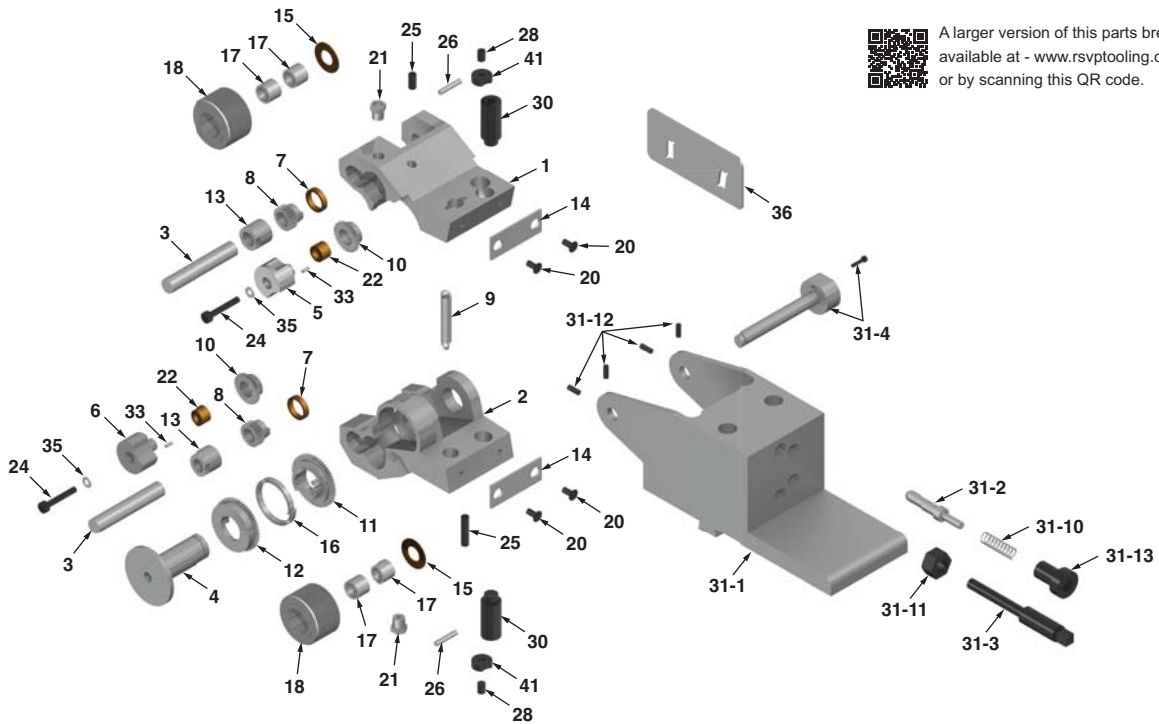

A larger version of this parts breakdown is available at - www.rsvptooling.com/prints.html or by scanning this QR code.

Item #	EDP	Description	Qty
1	20-001	Upper Arm	1**
2	20-002	Lower Arm	1
3	20-003	Shaft	2
4	20-004	Center Shaft	1
5	20-005	Bushing	1
6	20-006	Bushing	1
7	20-007	Bearing Bushing	2
8	20-008	Pinion	2
9	20-009	Tension Spring	1
10	20-010	Gear w/Bushing	2
11	20-011	Gear (assy w/12 & 16 only)	0**
12	20-012	Gear w/Coil Spring	1
13	20-013	Carbide Bushing	2
14	20-014	Plate	2

Item #	EDP	Description	Qty
15	20-015	Thrust Washer	2
16	20-016	Coil spring (assy w/11 & 12)	1
17	20-017	Bushing	4
20	20-020	Flat Head Scr.	4
21	20-021	Grease Nipple	2
22	20-022	Bearing Bushing	2
24	20-024	Cap Screw	2
25	20-025	Cap Screw	2
26	20-026	Straight Pin	2
27	20-027	Set Screw	1
28	20-028	Set Screw	2
30	20-030	Adj. Set Screw	2
31	20-031	Attachment Holder Complete	1*
31-1	20-031-1	Housing	1*

Item #	EDP	Description	Qty
31-2	20-031-2	Spring Loded Bolt	1
31-3	20-031-3	Stop Bolt	1
31-4A	20-031-4A	Bolt	1
31-4B	20-031-4B	Bolt	1
31-10	20-031-10	Thrust Spring	1
31-11	20-031-11	Hex Nut	1
31-12	20-031-12	Set Screw	2
31-13	20-031-13	Cap Screw	1
32	20-032	Setting Gauge	1*
33	20-033	Slotted Pin	2
35	20-035	Schnorr Clip	2
36	20-036	Sheet Metal Gauge	1
41	20-041	Lock Washer	2

Sold as an assembly only
 *(#1 & #2 Arm Assy) (#11,12 & 16 gear w/Coil Spring Assy)
 *Per Application

RT-30 Tangential Side Thread Rolling Attachment

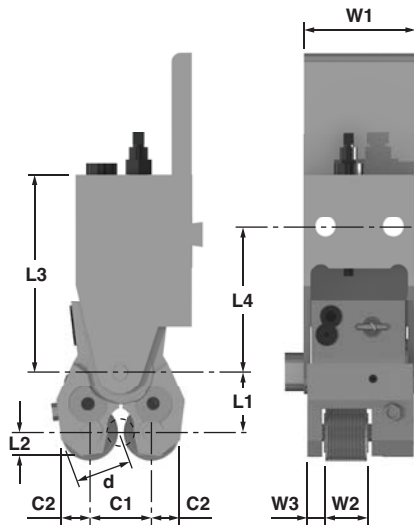

Dmax = max. shoulder diameter
 Av = Operating feed
 Dimensions above refer to cross slide mounted holder.
 Dimensions for other tool holder are adapted to the respective machine.

Roiling Attachment		RT30
W1 mm/inch		83 / 3.268
W2 mm/inch		31 / 1.22
W3 mm/inch		15.8 / 0.622
L1 mm/ Inch min./max.		43.1 / 1.697
L2 mm/inch		53.5 / 2.106
L3 mm/inch		20 / 0.787
L4 mm/inch		124 / 4.882
C1 mm/inch min./max.		59.5 / 2.343
C2 mm/inch		87 / 3.425
d mm/inch max.		28/1.102
L4		63 / 2.48
Weight Approx. (kg)	Rolling Attachment	4.9
	Rolling Attachment Holder	4.2
	Thread rolls (1 set = 2 pieces)	1.4
	Setting gauge	0.2
	Total	10.7

For left hand threads, the same rolling attachment can be used as for right hand threads. Left hand threads require left hand rolls.

Component Parts Breakdown

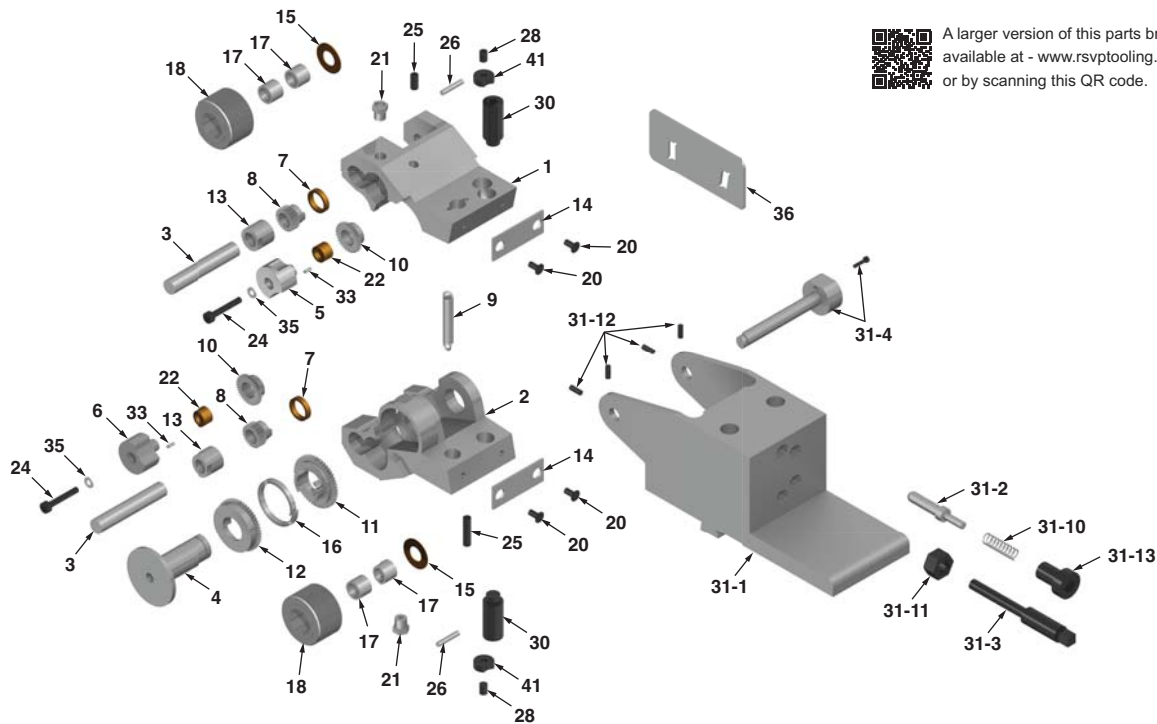

A larger version of this parts breakdown is available at - www.rsptooling.com/prints.html or by scanning this QR code.

Item #	EDP	Description	Qty
1	30-001	Upper Arm	1**
2	30-002	Lower Arm	1
3	30-003	Shaft	2
4	30-004	Center Shaft	1
5	30-005	Bushing	1
6	30-006	Bushing	1
7	30-007	Bearing Bushing	2
8	30-008	Pinion	2
9	30-009	Tension Spring	1
10	30-010	Gear w/Bushing	2
11	30-011	Gear (assy w/12 & 16 only)	0**
12	30-012	Gear w/Coil Spring	1
13	30-013	Carbide Bushing	2
14	30-014	Plate	2

Item #	EDP	Description	Qty
15	30-015	Thrust Washer	2
16	30-016	Coil spring (assy w/11 & 12)	1
17	30-017	Bushing	4
20	30-020	Flat Head Scr.	4
21	30-021	Grease Nipple	2
22	30-022	Bearing Bushing	2
24	30-024	Cap Screw	2
25	30-025	Cap Screw	2
26	30-026	Straight Pin	2
27	30-027	Set Screw	1
28	30-028	Set Screw	2
30	30-030	Adj. Set Screw	2
31	30-031	Attachment Holder Complete	1▼
31-1	30-031-1	Housing	1▼

Item #	EDP	Description	Qty
31-2	30-031-2	Spring Loded Bolt	1
31-3	30-031-3	Stop Bolt	1
31-4A	30-031-4A	Bolt	1
31-4B	30-031-4B	Bolt	1
31-10	30-031-10	Thrust Spring	1
31-11	30-031-11	Hex Nut	1
31-12	30-031-12	Set Screw	2
31-13	30-031-13	Cap Screw	1
32	30-032	Setting Gauge	1▼
33	30-033	Slotted Pin	2
35	30-035	Schnorr Clip	2
36	30-036	Sheet Metal Gauge	1
41	30-041	Lock Washer	2

Sold as an assembly only

▼(#1 & #2 Arm Assy) (#11,12 & 16 gear w/Coil Spring Assy)

▼ Per Application



TANGENTIAL Thread Rolls

Unified Threads			
Thread Size	RT10	RT20	RT30
2-56 UNC	X	X	
2-64 UNF	X	X	
3-48 UNC	X	X	
3-56 UNF	X	X	
4-40 UNC	X	X	
4-48 UNF	X	X	
5-40 UNC	X	X	
5-44 UNF	X	X	
6-32 UNC	X	X	
6-40 UNF	X	X	
8-32 UNC	X	X	
10-24 UNC	X	X	
10-32 UNF	X	X	
12-24 UNC	X	X	
12-28 UNF	X	X	
12-32 UNEF	S	S	
1/4-20 UNC	X	X	X
1/4-28 UNF	X	X	X
1/4-32 UNEF	S	S	S
5/16-18 UNC	X	X	X
5/16-24 UNF	X	X	X
5/16-32 UNEF	S	S	S
3/8-16 UNC	X	X	X
3/8-24 UNF	X	X	X
3/8-32 UNEF	S	S	S
7/16-14 UNC		X	X
7/16-20 UNF	X	X	X
7/16-28 UNEF	S	S	S
1/2-13 UNC	X	X	
1/2-20 UNF	X	X	X
1/2-28 UNEF	S	S	S
9/16-12 UNC		X	X
9/16-18 UNF	X	X	X
9/16-24 UNEF	S	S	S
5/8-11 UNC			X
5/8-18 UNF		X	X
5/8-24 UNEF		S	S
1 1/16-24 UNEF		S	S
3/4-10 UNC		X	X
3/4-16 UNF		X	X
3/4-20 UNEF		X	X
13/16-20 UNEF		S	S
7/8-14 UNF		X	X
7/8-20 UNEF		X	X
15/16-20 UNEF		S	S
1-12 UNF		X	X
1-20 UNEF		X	X
1-1/16-18 UNEF		S	S
1-1/8-12 UNF		X	X
1-1/8-18 UNEF		S	S
1-3/16-18 UNEF		S	S
NPT/NPTF Threads			
1/16-27	X	X	X
1/8-27	X	X	X
1/4-18		X	X
3/8-18		X	X
1/2-14		X	X
3/4-14		X	X
1-11.5			X
1-1/4-11.5			X

Standard Rolls For
Rolling Heads "X" Indicates Standard
For Designed Head Size "S" Indicates Special

Standard Roll Widths

RT10 Rolls Available In: 4MM, 6MM, 8MM, 10MM, 12MM, 14MM, 15.5MM

RT20 Rolls Available In: 6MM, 8MM, 10MM, 12MM,
14MM, 16MM, 18MM, 21.5MM

RT30 Rolls Available In: 8MM, 10MM, 12MM, 14MM, 16MM, 18MM,
20MM, 22MM, 24MM, 26MM, 28MM, 30MM

Thread Rolls Are Interchangeable With:

RT10 with T12 **RT20** with T18 **RT30** with T27

Metric Threads			
Thread Size	RT10	RT20	RT30
M2 X 0.4	X		
M2.2 X 0.45	X		
M2.5 X 0.45	X		
M3 X 0.5	X	X	
M3.5 X 0.5	X	X	
M4 X 0.7	X	X	
M5 X 0.8	X	X	
M5 X 0.5	S	S	
M6 X 1	X	X	X
M6 X 0.75	S	S	S
M6 X 0.5	S	S	S
M8 X 1.25	X	X	X
M8 X 1.25	X	X	X
M8 X 0.75	S	S	S
M8 X 0.5	S	S	S
M10 X 1.5	X	X	X
M10 X 1.25	X	X	X
M10 X 1	X	X	X
M10 X 0.75	S	S	S
M12 X 1.75		X	X
M12 X 1.5	X	X	X
M12 X 1.25	X	X	X
M12 X 1	X	X	X
M14 X 2		X	X
M14 X 1.5	X	X	X
M14 X 1.25	X	X	X
M14 X 1	X	X	X
M16 X 2		X	X
M16 X 1.5		X	X
M16 X 1.5		X	X
M16 X 1		X	X
M18 X 2		X	X
M18 X 1.5		X	X
M18 X 1.5		X	X
M20 X 2		X	X
M20 X 1.5		X	X
M20 X 1		X	X
M22 X 2		X	X
M22 X 1.5		X	X
M22 X 1		X	X
M24 X 2		X	X
M24 X 1.5		X	X
M24 X 1		X	X
M26 X 1.5		X	X
M27 X 2		X	X
M27 X 1.5		X	X
M28 X 1.5		X	X
M30 X 2		X	X
M30 X 1.5		X	X
M33 X 2			X
M33 X 1.5			X
M35 X 1.5			X
M36 X 2			X
M36 X 1.5			X
M39 X 2			X
M39 X 1.5			X
M40 X 1.5			X
M42 X 2			X
M42 X 1.5			X
Whitworth Pipe Parallel			
G1/8-28	X	X	X
G1/4-19	X	X	X
G3/8-19		X	X
G1/2-14		X	X
G5/8-14		X	X
G3/4-14		X	X
G7/8-14			X
G1-11			X
G1-1/8-11			X
G1-1/4-11			X

TANGENTIAL We Make Other Rolls To Fit Most Heads

RSVP's Tangential Thread Rolling Head rolls are designed to offer:

- Better performance
- Increased productivity by reducing set up times
- Better threading efficiency.

RSVP's Tangential system is interchangeable with the Fette style tangential thread rolling system. We can manufacture custom and standard rolls to fit into your existing tangential holders such as Reed, Winter, and Salvo style rolls.

When ordering or requesting a quotation on thread rolls the following information should be provided.

1 Type of roll

- C-1, C-2, F1-ff ect.
- Working face or hub dimension when applicable.
- Die prints when possible.

2. Attachment or machine size and type.

3. Part details

- Thread size.
- Length of thread.
- Position and size of should on part if applicable.

Thread rolls are also available for three die machines and can be made for a wide variety of specialty machines.

Contact RSCVP Tooling for further assistance in placing your custom or standard Tangential thread roll order.

Thread Rolls For Standard Attachments (Two Dies/Set)

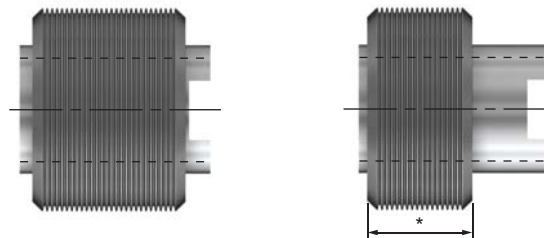

C-1

C-2

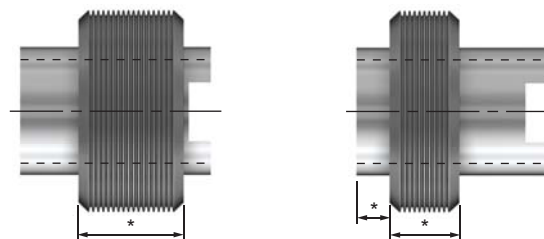

C-3

C-4

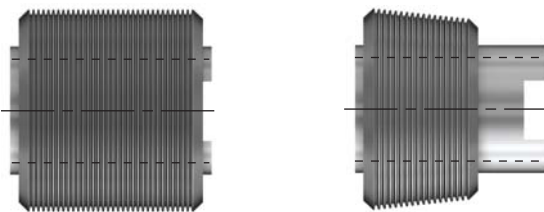

D-1

K-2



Q-2

CR-1

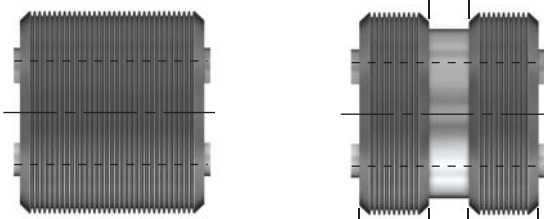

DR-1

DR-5

Bump Type Thread Rolls (Single Roll)



F1 Style
Full Width
Work Face

F2 Style
Variable
Work Face

Y2 Style
Pipe Rolls

Pipe Rolls	
Size	Workface
1/8-27	.357
1/4-18	.541
3/8-18	.547
1/2-14	.712
3/4-14	.724

Other workfaces may be provided - as requested.

* Dimensions must be supplied by the customer.

SPLINE Rolling Head - "RS" Series

Synchronized Spline Rolling Head

The "E" Series heads operate in a way similar to a three jaw chuck, but use an adjustment mechanism that is much more precise and repeatable. The three dies are adjusted with a single adjustment, and locked in position (the die slides do not open during the rolling cycle). If required, the slides can easily be adjusted individually.

To prevent mis-tracking, a springloaded shaft holds a synchronizing gear in position between the dies. When rolling, the gear is pushed ahead of the part and into the rolling head. When the correct depth is reached, the part is retracted and the gear follows the part (under spring pressure) back into position, to re-synchronize the rolls.

Available In Two Sizes:

- The 150E measure 4" diameter, and extends 3" from the turret mounting face.
- The 200E measures 4.5" diameter, and extends 3" from the turret mounting face.
- Standard mounting shanks run from 3/4" to 1-1/2" diameter, in 1/4" increments, and measure 3" long.



ZEUS Cut Knurling Tools

Knurling without pressure and force.

Unbeatable benefits:

- **Flexible use** for shanks 20 and 25 through vertical adjustment mechanism.
- **High precision** for excellent knurling profiles.
- **Modular tool system** for left and right hand orientation with easy tool conversion.
- **Fast and easy head orientation** reduces setting time.
- **Easy tool handling** and adjustment of work piece diameter.
- **Rigid tool design** offers high process safety and excellent knurling quality. Gear tooth system between tool holder and cut knurling head for a steady vibration free process.
- **Knurling wheel options:** PVD coatings for increased wheel life.
- **Special surface hardening** of the tool shank for increased tool life (nitriding).

Zeus Cut Knurling Wheels guarantee an optimal tool life, high precision & absolute process safety:

- **Teeth fine milled, front and bore ground:** high quality of knurling pattern.
- **Vacuum hardened.**
- **Knurling wheel options:** PVD coatings for increased wheel life (3).
- **Exclusive product range.**

RSVP Tooling is proud to be the North American stock master distributor for Homell Keller Zeus knurling and marking tools. RSVP Tooling offers knurling and marking tool solutions to meet a wide range of production specifications and demands. For a complete listing of Zeus Knurling and Marking tools visit <http://www.zeus-tooling.de/en/products> or scan this QR code.



Best Example:
Zeus RF2-A

Tool Series:

RF1

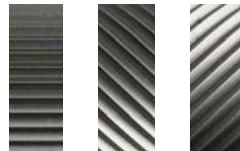

Knurling profiles:
RAA / RBL / RBR

RF2

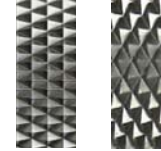

Knurling profiles:
RGE30° / RGE45°

RF3

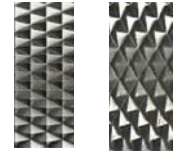

Knurling profiles:
RGE30° / RGE45°



Form AA



BL 15°



BR 15°



BL 30°



BR 30°

Variations	Type	Ø x width x bore	Pitch p - Profile angle a
No.15 / milled, without chamfer, HSS ✓	AA	8,9 x 2,5 x 4 ✓	0,3 - 90°
No.16 / milled, without chamfer, PM ✓	BL 15°	10 x 3 x 6 ✓	0,4 - 90°
No.17 / milled, with chamfer, HSS ✓	BR15°	14,5 x 3 x 5 ✓	0,5 - 90°
No.18 / milled, with chamfer, PM ✓	BL30°	15 x 4 x 8 ✓	0,6 - 90°
No.35 / ground, without chamfer, PM ✓	BR30°	21,5 x 5 x 8 ✓	0,7
No.37 / ground, with chamfer, PM ✓		25 x 6 x 8 ✓	0,8
No.55 / ground, without chamfer, HM ✓		32 x 13 x 16 ✓	0,9
No.57 / ground, with chamfer, HM ✓		42 x 13 x 16 ✓	1,0
			1,2
			1,5
			1,6
			1,8
			2,0 - 90°

Please choose your options by combining the four columns accordingly. HSS = High Speed Cutting Steel PM = Powder metallurgy Steel HM = Carbide

ZEUS Form Knurling Tools

Optimal solutions for knurling applications.

Unbeatable benefits:

- **High precision** for excellent knurling profiles. Low radial pressure on the work piece.
- **Easy tool handling** and adjustment of work piece diameter. With scale for setting the work piece Ø.
- **Rigid tool design** offers high process safety and excellent knurling quality.
- **Knurling wheel options:** PVD coatings for increased wheel life.
- **Special surface hardening** of the tool shank for increased tool life (nitriding).
- **Application oriented** tool solutions. Suitable for small machines and small work piece diameters.

Zeus Form Knurling Wheels guarantee an optimal tool life, high precision and absolute process safety:

- **Teeth fine milled, front and bore ground:** high quality of knurling pattern
- **Vacuum hardened:** increase in tool life
- **Knurling wheel options:** PVD coatings for increased wheel life (✓)
- **Exclusive product range**

RSVP Tooling is proud to be the North American stock master distributor for Homell Keller Zeus knurling and marking tools. RSVP Tooling offers knurling and marking tool solutions to meet a wide range of production specifications and demands. For a complete listing of Zeus Knurling and Marking tools visit <http://www.zeus-tooling.de/en/products> or scan this QR code.



Best Example:
Zeus RD2

Tool Series:

RD1

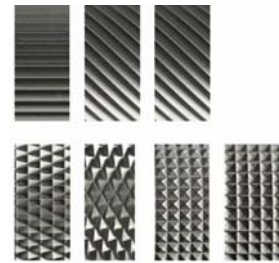

All knurling profiles possible

RD2

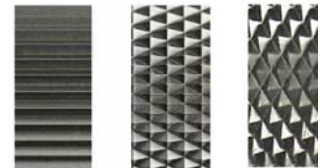

RAA, RGE30°, RGE45°

RD3

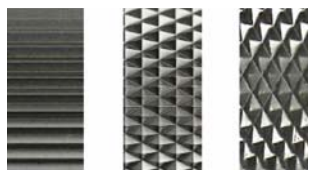

RAA, RGE30°, RGE45°

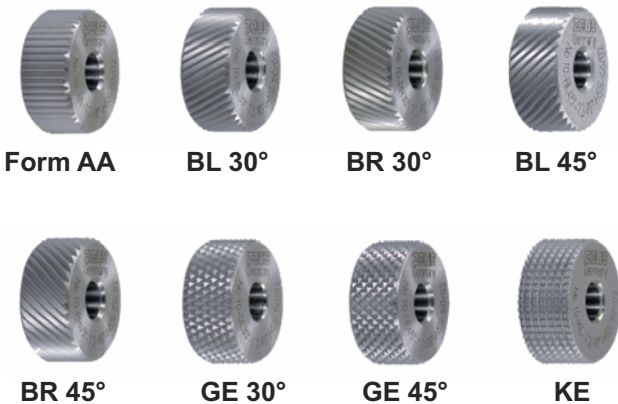

Form AA

BL 30°

BR 30°

BL 45°

BR 45°

GE 30°

GE 45°

KE

ZEUS Marking Tools - Turned Part Marking On (Auto) Lathe

Leave your mark with Zeus marking tools.

Unbeatable benefits:

- **Application oriented** tool solutions. Marking of work pieces on the (auto) lathe directly.
- **Customized tool** solutions. Each tool is designed according to the applications specific requirements.
- **Cost reduction.** No additional manual processing step or additional setting time required.
- **Individuality.** Branding of turned-parts with company name or logo.

Turned part marking application benefits:

- **Unique product allocation and traceability** through product identification
- **Unique supplier allocation**
- **Improved production data**
- **Branding possibilities**



Leave your mark with Zeus marking tools.

Marking Rolls:

- **Customer oriented tool solutions.** Individual tool design for your specific application.
- **Individual design.** Each marking roll is designed to the customer's specific requirements.
- **Cost effective.** Customized solutions for standard price.

RSVP Tooling is proud to be the North American stock master distributor for Homell Keller Zeus knurling and marking tools. For a complete listing of Zeus Knurling and Marking tools visit <http://www.zeus-tooling.de/en/products> or scan this QR code.



Best Example:
Zeus MRS1

Tool Series:



MC1



MRS1



MR1

Spring Return Marking System:



No. 41
Marking roll partially rotating

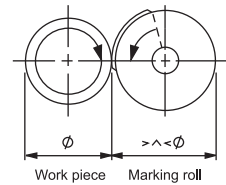

For marking tools:
MR1 - Series

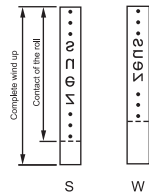

Marking types
on work piece



Continuous Roll Marking System:



No. 40
Marking roll continuously rotating

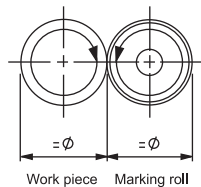

Marking types
on work piece

For marking tools:
MC1 - Series
MCC1 - Series

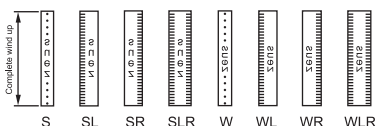

No. 41
Marking roll partially rotating

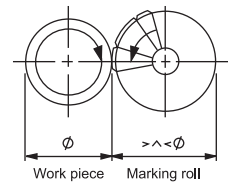

For marking tools:
MRS1 - Series

Marking types
on work piece

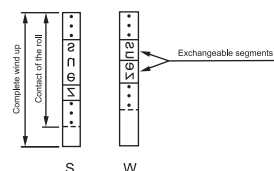

BAUBLIES Precision Burnishing Tools

RSVP Tooling is proud to be the North American source for Baublies precision roller and diamond burnishing tools.

We offer a complete range of sizes and styles to suit any application regardless of how large or small.

Please contact us with your application and we will be happy to provide a complete comprehensive solution for you.

Complete product catalogs and video representations are available at www.rsvptooling.com and follow our link to Baublies Burnishing Tools.

Or contact our office directly and we will be able to assist you.



RSVP Tooling
Home Page



Baublies Burnishing Tools
Home Page

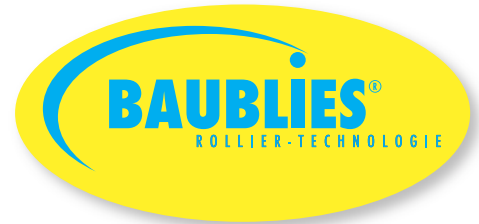

TOOLHOLDER Solutions

RSVP Tooling is partnered with several expert tool manufacturers and can provide an economic tool holding solution for virtually any application.

We apply these products to supplement our standard product lines to accommodate the many difficulties that can be encountered when machining difiicult components or adapting a machine to a specific operation.

Contact our office and we will be happy to work with you to find the best approach to your situation.



RSVP Tooling
Home Page





Contact Information

RSVP Tooling, Inc.

Toll Free: 888-289-7787

Direct: 815-725-3310

Fax: 815-725-3391

Email: sales@rsvptooling.com

www.rsvptooling.com



Website Link