

reCool®

*The first of its kind system
to convert existing live
tooling to through coolant*

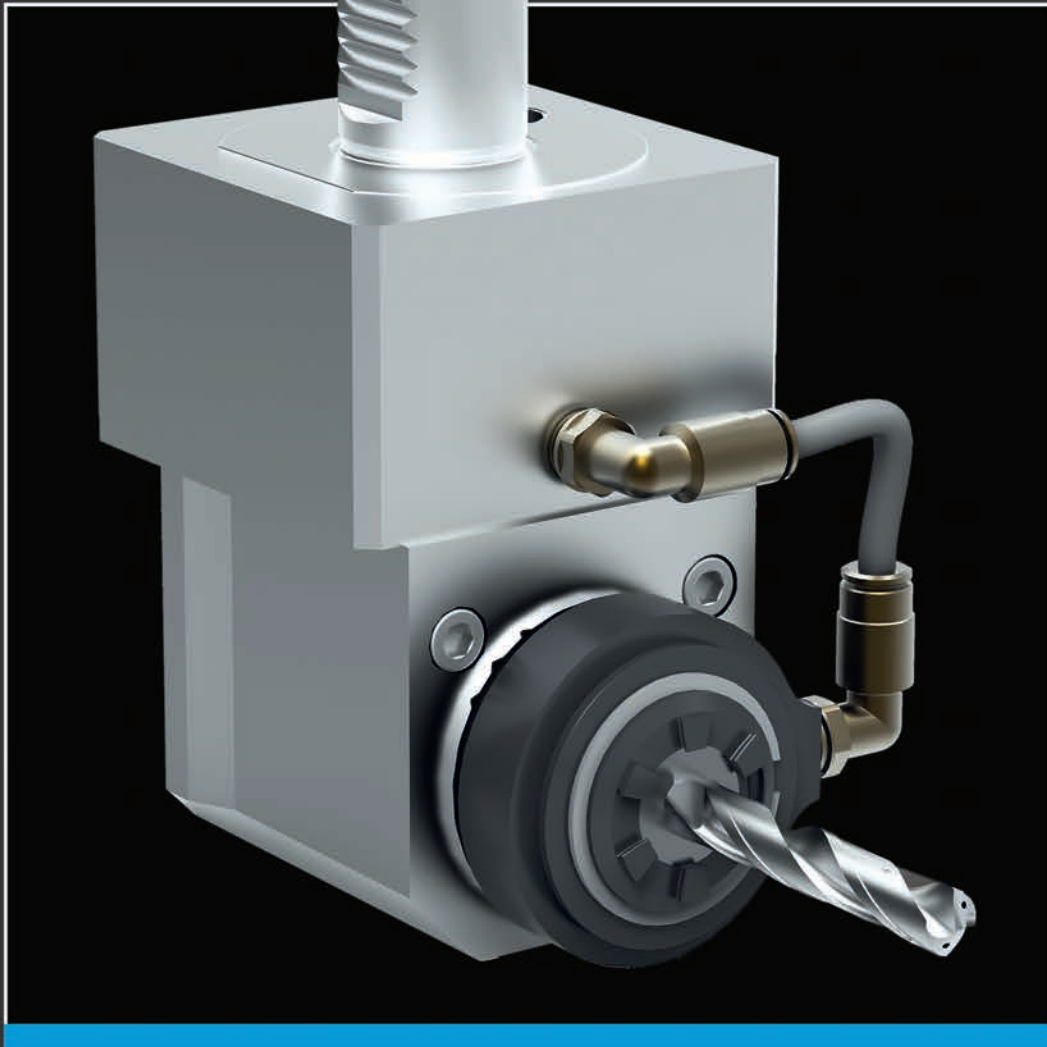

No internal cooling? reCool from REGO-FIX converts existing live tooling systems to through coolant...in only two minutes and at low costs.

- For live tools with externally threaded nuts and ER collets
- Speeds up to 6,000 rpm*
- Coolant pressures up to 20 bar/300 PSI*
- Maintenance free coolant lubricated bearings
- Swiss manufactured for high-quality and long life

*Higher speeds and coolant pressures on request

www.rego-fix.com
800.999.7346
info@reg-fix.com

Made in
Switzerland



Swiss
Precision
Tools



REGO-FIX®



Benefits of Internal Cooling with reCool

- Optimized coolant for all tools and for difficult to access machining
- Suitable for use with the REGO-FIX Coolant disk or Coolant flush systems
- More coolant reaches the cutting tool without splattering or spray losses
- Tool lubrication is optimized via through tool coolant
- Increased chip removal

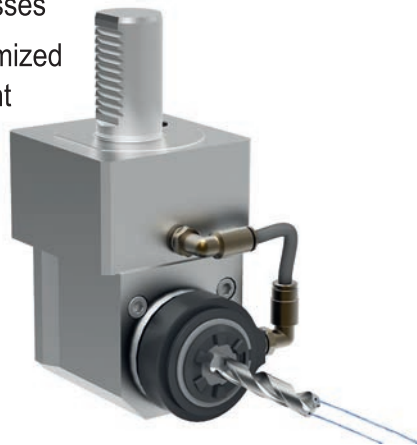

reCool Coolant Supply set includes:

- 1 reCool clamping nut with outer ring
- 2 Coolant pipe with protector (0.6mm, 400 mm length)
- 3 1/8" BSP straight push-in fitting
- 4 1/8" BSP elbow push-in fitting

Type	Part No.
RCR/ER 16	3716.00000
RCR/ER 20	3720.00000
RCR/ER 25	3725.00000
RCR/ER 32	3732.00000
RCR/ER 40	3740.00000

Notes:

- 1) Designed for water-based coolant systems not oil-based
- 2) Collets, disks & wrenches not included

Peripheral cooling without reCool

- Adjustment and control of the nozzles or spray tubes with different tool length and tool diameter is limited
- Coolant may not be direct at the cutting edge resulting in higher wear on the cutting tool
- Splattering losses of the spray jet
- Poor chip removal



Watch reCool in action



REGO-FIX TOOL CORPORATION

7752 Moller Road
Indianapolis, IN 46268 USA

Toll Free: 800.999.7346

Phone: 317.870.5959

Fax: 317.870.5955

Email: info@rego-fix.com

www.rego-fix.com