

LAMBRICH USA

European Quality. Unforgettable Design. Exceptional Value.

2022



Distributed By:

AHB
TOOLING & MACHINERY

**COMPLETE
METALWORKING
SOLUTIONS**

(800) 991-4225

www.ahbinc.com





ISO Certified

customerservice@ahbinc.com

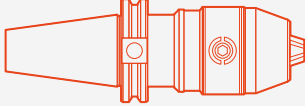
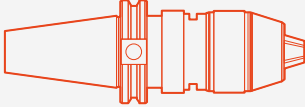
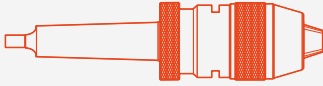

llambrichusa.com

Drill Chucks

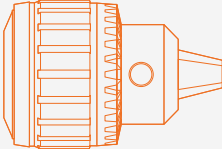
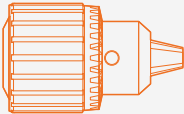
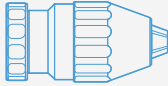
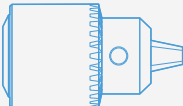
			Keyed or Keyless	Maximum Runout	Integrated Shank	Capacity Up To
Super-High Precision Certified Series		Hexa	Keyed Hexagonal Key Lock System	0.0012" ★ CERTIFIED ★ ACCURACY	YES	5/8"
High Precision Certified Series		NPU	Keyless w/ Supplemental Wrench	0.0016" ★ CERTIFIED ★ ACCURACY	YES	5/8"
		JK Solid	Keyless w/ Supplemental Wrench	0.0016" ★ CERTIFIED ★ ACCURACY	YES	5/8"
		JKP	Keyless	0.0016" ★ CERTIFIED ★ ACCURACY	NO	5/8"
		JKT	Keyless w/ Supplemental Wrench	0.0016" ★ CERTIFIED ★ ACCURACY	NO	5/8"
Production Series		JK Industrial	Keyless	-	NO	3/4"
		CBB	Keyed	-	NO	1"
		CY	Keyed	-	NO	3/4"
Stainless Steel INOX Series		SP	Keyless	-	NO	0.291"
		CSS	Keyed	-	NO	0.291"

Mounting Style Options	Rotational Direction	Instant Stop Spindle	Page
CAT BT R-8	Permits Counter-Clockwise Rotation	Resists Tool Loosening on Instant Stop Spindle	6
CAT BT	Clockwise Rotation	Resists Tool Loosening on Instant Stop Spindle	7
Morse Taper Straight Shank R-8	Clockwise Rotation	Resists Tool Loosening on Instant Stop Spindle	8
Threaded Jacobs Taper	Clockwise Rotation	-	9
Jacobs Taper	Clockwise Rotation	Resists Tool Loosening on Instant Stop Spindle	10
Threaded Jacobs Taper	Clockwise Rotation	-	11
Jacobs Taper	Permits Counter-Clockwise Rotation	Resists Tool Loosening on Instant Stop Spindle	12
Threaded Jacobs Taper	Permits Counter-Clockwise Rotation	Resists Tool Loosening on Instant Stop Spindle	13
Threaded Jacobs Taper	Clockwise Rotation	-	14
Threaded Jacobs Taper	Permits Counter-Clockwise Rotation	Resists Tool Loosening on Instant Stop Spindle	15



16 Arbors & Sleeves

Completely Hardened and Precision Ground



18 Live Centers

PRECISION WORKHOLDING

Live Centers for Accurate Work Holding in Conventional or CNC Lathes



20 Llambrich® Cross Reference

Easy Conversion from Jacobs®, Albrecht®, LFA® and Rohm®



22 Drill Chucks 101

Know Your Drill Chuck?

Quality Engineering

Llambrich® originated from the province of Barcelona, Spain and has been designing, engineering and manufacturing drill chucks and machine tool accessories since 1957.

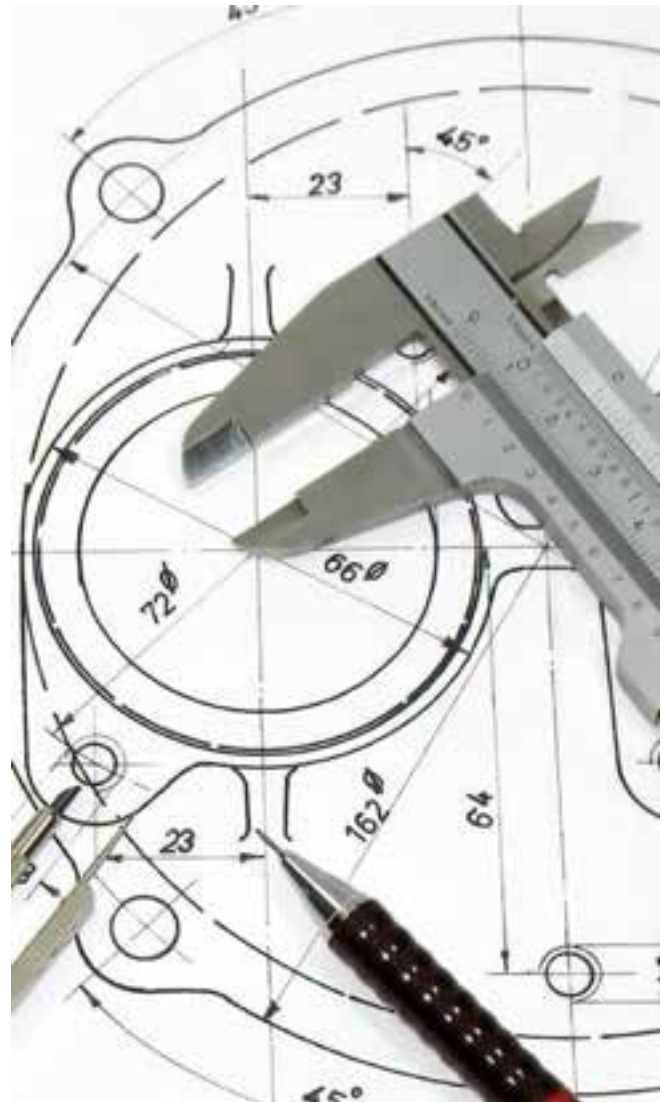

**CAN'T FIND WHAT YOU'RE
LOOKING FOR? JUST ASK!**

**ADDITIONAL CONFIGURATIONS INCLUDING
DIN MOUNTS AVAILABLE, INQUIRE AT
SALES@QTIMPORTS.COM**

MANUFACTURER'S WARRANTY

Llambrich® guarantees all products that it manufactured and marketed to be free of any manufacturing defects. Without notice, Llambrich® Manufacturing Company can reserve the right to change the design, material composition and dimensional specifications for all products offered in this catalog.



Since 1957

Guarantee Of Accuracy

Llambrich® has been the pioneer and inventor of the precision keyless chuck that guarantees the lowest run-out of concentricity since 1983. All high performance drill chucks come with a certificate of inspection that guarantees a maximum run-out of 0.0016" (0.0012" for Hexa drill chucks). All chucks are precision tested and certified. Inspections for concentricity are performed adhering to the most demanding standards in the metalworking industry.

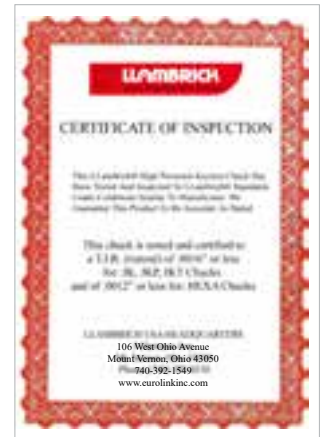

HEXA

Super-High Precision Drill Chuck with Integrated Shank & Hexagonal Key Lock

For use on CNC machining centers

- Hexagonal key lock system (key included)
- Permits clockwise and counterclockwise turning

Optional balancing service up to 25,000 RPM at G6.3
(Max RPM without balancing: 8,000)

INTEGRATED SHANK

Compact Construction Significantly shorter than two-piece chuck and arbor.

Higher Precision A single taper connection to the machine without intermediate arbor provides maximum rigidity and concentricity.



★ CERTIFIED ★
ACCURACY
MAX. RUNOUT
0.0012"

GRIPPING
TORQUE
+75 ft/lbs

CAPACITY
UP TO
5/8"

HEXAGONAL KEY



CAT

EDP	PART	CAPACITY	MOUNT	DIMENSIONS		
Number	Number	Inches	Style	Ø	L1	L2
L40020B	HX-13 CA-40	1/32 - 1/2	CAT40	2.126	4.213	4.567
L40026B	HX-16 CA-50	1/8 - 5/8	CAT50	2.244	3.583	3.858

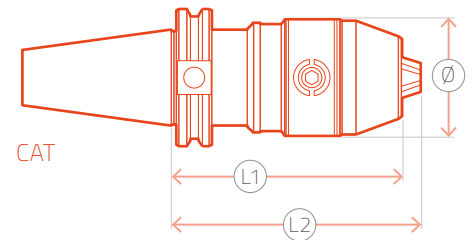

BT

EDP	PART	CAPACITY	MOUNT	DIMENSIONS		
Number	Number	Inches	Style	Ø	L1	L2
L40008B	HX-13 BT-40	1/32 - 1/2	BT40	2.126	3.780	4.134

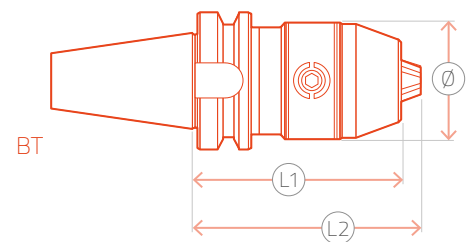

R-8

EDP	PART	CAPACITY	MOUNT	DIMENSIONS		
Number	Number	Inches	Style	Ø	L1	L2
L40049B	HX-13 R-8	1/32 - 1/2	R-8	2.126	3.346	3.701
L40050B	HX-16 R-8	1/8 - 5/8	R-8	2.244	3.465	3.740

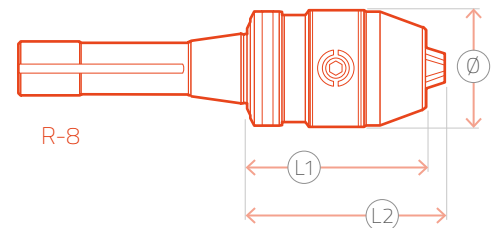

NPU

High Precision Short Keyless Drill Chuck with Integrated Shank

For use on CNC machining centers

- Engineered with milled flats for supplemental gripping torque up to three times higher than hand tightening. (Spanner Wrench included)
- Resists tool loosening on high-speed machines with instant spindle stop
- Smaller capacities available on request for all NPU models

INTEGRATED SHANK

Compact Construction Significantly shorter than two-piece chuck and arbor.

Higher Precision A single taper connection to the machine without intermediate arbor provides maximum rigidity and concentricity.



★ CERTIFIED ★
ACCURACY
MAX. RUNOUT
0.0016"

CAPACITY
UP TO
5/8"

SUPPLEMENTAL
TIGHTENING

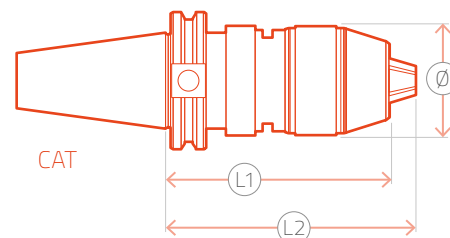

CAT

EDP	PART	CAPACITY	MOUNT	DIMENSIONS		
Number	Number	Inches	Style	∅	L1	L2
L40286B	NPU-08 CA 40-A	1/64 - 5/16	CAT40	1.496	3.228	3.464
L40287B	NPU-13 CA 40-A	1/32 - 1/2	CAT40	1.889	4.527	4.960
L40289B	NPU-13 CA 50-A	1/32 - 1/2	CAT50	1.889	3.779	4.212
L40290B	NPU-16 CA 40-A	1/8 - 5/8	CAT40	2.165	4.724	5.157
L40291B	NPU-16 CA 50-A	1/8 - 5/8	CAT50	2.165	3.700	4.133

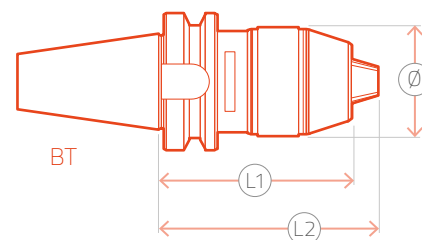

BT

EDP	PART	CAPACITY	MOUNT	DIMENSIONS		
Number	Number	Inches	Style	∅	L1	L2
L40267B	NPU-08 BT 40	1/64 - 5/16	BT40	1.496	3.070	3.307
L6339B	NPU-13 BT 40	1/32 - 1/2	BT40	1.889	3.385	3.818
L40273B	NPU-13 BT 50	1/32 - 1/2	BT50	1.889	3.818	4.251
L40274B	NPU-16 BT 40	1/8 - 5/8	BT40	2.165	4.133	4.566
L40275B	NPU-16 BT 50	1/8 - 5/8	BT50	2.165	3.740	4.173



**CAN'T FIND WHAT YOU'RE
LOOKING FOR? JUST ASK!**

ADDITIONAL CONFIGURATIONS INCLUDING
DIN MOUNTS AVAILABLE, INQUIRE AT
SALES@QTIMPORTS.COM

JK-Solid

Self-Tightening High Precision Keyless Drill Chuck with Integrated Shank

- The JK-Solid is a high precision integrated shank keyless drill chuck. The one piece construction offers a tighter tolerance on T.I.R.
- Greater rigidity and precision
- Engineered with milled flats for supplemental gripping torque up to three times higher than hand tightening. (Spanner Wrench included)
- Resists tool loosening on high-speed machines with instant spindle stop

INTEGRATED SHANK

Compact Construction Significantly shorter than two-piece chuck and arbor.

Higher Precision A single taper connection to the machine without intermediate arbor provides maximum rigidity and concentricity.



★ CERTIFIED ★
ACCURACY
MAX. RUNOUT
0.0016"

CAPACITY
UP TO
5/8"

SUPPLEMENTAL
TIGHTENING



Morse Taper

EDP	PART	CAPACITY	MOUNT	DIMENSIONS			
Number	Number	Inches	Style	∅	L1	L2	
L31406B	JK-08 MT2	1/64 - 5/16	MT2	1.496	2.559	2.835	--
L31407B	JK-10 MT2	1/32 - 3/8	MT2	1.693	2.874	3.228	--
L31408B	JK-13 MT2	1/32 - 1/2	MT2	1.890	3.150	3.622	--
L31409B	JK-13 MT3	1/32 - 1/2	MT3	1.890	3.150	3.622	--
L31410B	JK-13 MT4	1/32 - 1/2	MT4	1.890	3.150	3.622	--
L31413B	JK-16 MT2	1/8 - 5/8	MT2	2.126	3.346	3.780	--
L31414B	JK-16 MT3	1/8 - 5/8	MT3	2.126	3.346	3.780	--
L31415B	JK-16 MT4	1/8 - 5/8	MT4	2.126	3.346	3.780	--

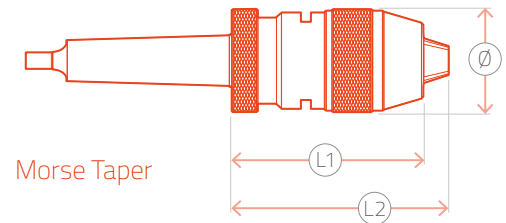

Straight Shank

EDP	PART	CAPACITY	MOUNT	DIMENSIONS			
Number	Number	Inches	Style	∅	L1	L2	L3
L31412B	JK-130 5/8	1/32 - 1/2	5/8 SS	1.890	3.150	3.622	2.480

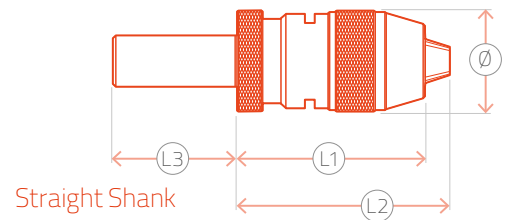

R-8

EDP	PART	CAPACITY	MOUNT	DIMENSIONS			
Number	Number	Inches	Style	∅	L1	L2	
L31411B	JK-130 R-8	1/32 - 1/2	R-8	1.890	3.228	3.543	--
L31416B	JK-160 R-8	1/8 - 5/8	R-8	2.126	3.425	3.858	--

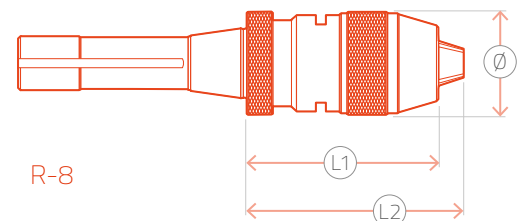



Self-Tightening High Precision Keyless Drill Chuck

- Self-tightening mechanism automatically increases the clamping forces in proportion to the increase in torque during the drilling operation. This prevents tool slippage in clockwise rotation.
- For right-hand rotation applications only
- Use on high accuracy drill presses, jig borers, milling machines and production drilling equipment.
- All components exposed to wear are completely hardened to maintain accuracy and extend chuck life.
- Left hand rotation is available upon request
- Also available with through hole, for EDM machines, on demand



CAPACITY
UP TO
5/8"

EDP Number	PART Number	CAPACITY Inches	MOUNT Style	DIMENSIONS		
				∅	L1	L2
L31126B	JKP-30 J-0	1/64 - 1/8	JT0	0.965	1.732	1.870
L31127B	JKP-30 J-1	1/64 - 1/8	JT1	0.965	1.732	1.870
L31128B	JKP-30 R-5/16	1/64 - 1/8	5/16-24	0.965	1.732	1.870
L31121B	JKP-65 J-1	1/64 - 1/4	JT1	1.299	2.441	2.756
L40002B	JKP-80 J-1	1/64 - 5/16	JT1	1.496	2.638	2.913
L9679B	JKP-80 J-2S	1/64 - 5/16	JT2	1.496	2.638	2.913
L9681B	JKP-100 J-2	1/32 - 3/8	JT2	1.693	3.189	3.504
L9680B	JKP-100 J-33	1/32 - 3/8	JT33	1.693	3.189	3.504
L9683B	JKP-130 J-2	1/32 - 1/2	JT2	1.929	3.583	4.055
L9682B	JKP-130 J-33	1/32 - 1/2	JT33	1.929	3.583	4.055
L9684B	JKP-130 J-6	1/32 - 1/2	JT6	1.929	3.583	4.055
L40003B	JKP-160 J-33	1/8 - 5/8	JT33	2.165	3.740	4.213
L9685B	JKP-160 J-6	1/8 - 5/8	JT6	2.165	3.740	4.213

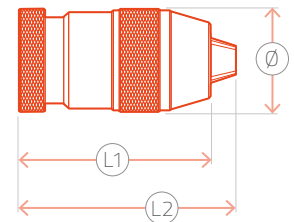

Jacobs Taper or
Threaded Mount

See **JKT** (page10), which includes milled flats for up to 3x the gripping force with a supplemental wrench.

**CAN'T FIND WHAT YOU'RE
LOOKING FOR? JUST ASK!**

ADDITIONAL CONFIGURATIONS INCLUDING
DIN MOUNTS AVAILABLE, INQUIRE AT
SALES@QTIMPORTS.COM



Self-Tightening High Precision Keyless Drill Chuck with Supplementary Gripping Torque

- Use on CNC machines in drilling, boring, counter-boring and milling operations requiring heavy feed.
- Engineered with milled flats for supplemental gripping torque up to three times higher than hand tightening. (Spanner Wrench included)
- Resists tool loosening on high-speed machines with instant spindle stop
- Self-tightening mechanism automatically increases the clamping forces in proportion to the increase in torque during the drilling operation. This prevents tool slippage in clockwise rotation.
- Left hand rotation is available upon request



★ CERTIFIED ★
ACCURACY
MAX. RUNOUT
0.0016"

CAPACITY
UP TO
5/8"

SUPPLEMENTAL
TIGHTENING

EDP Number	PART Number	CAPACITY Inches	MOUNT Style	DIMENSIONS		
				∅	L1	L2
L31122B	JKT-65 J-1	1/64 - 1/4	1JT	1.299	2.441	2.756
L30526B	JKT-80 J-2S	1/64 - 5/16	2JT	1.496	2.638	2.913
L30533B	JKT-100 J-2	1/32 - 3/8	2JT	1.693	3.189	3.504
L30532B	JKT-100 J-33	1/32 - 3/8	33JT	1.693	3.189	3.504
L30527B	JKT-130 J-2	1/32 - 1/2	2JT	1.929	3.583	4.055
L30528B	JKT-130 J-33	1/32 - 1/2	33JT	1.929	3.583	4.055
L30529B	JKT-130 J-6	1/32 - 1/2	6JT	1.929	3.583	4.055
L30530B	JKT-160 J-6	1/8 - 5/8	6JT	2.165	3.740	4.213

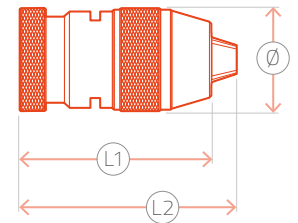

Jacobs Taper

If arbor is required, consider **JK-Solid** (page 8) with integrated shank for maximum rigidity and concentricity in a more compact single piece design.

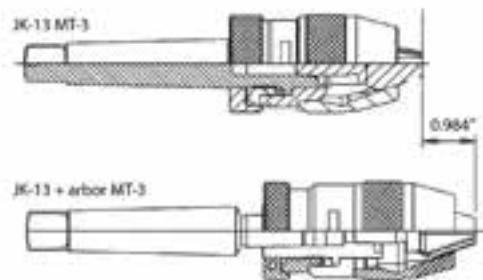

CAN'T FIND WHAT YOU'RE LOOKING FOR? JUST ASK!

ADDITIONAL CONFIGURATIONS INCLUDING DIN MOUNTS AVAILABLE, INQUIRE AT SALES@QTIMPORTS.COM

JK-Industrial

CAPACITY
UP TO
3/4"

Keyless Precision Drill Chuck

- Self-tightening mechanism automatically increases the clamping forces in proportion to the increase in torque during the drilling operation. This prevents tool slippage in clockwise rotation.
- Automatic fitting for efficient, fast change of tools

Threaded Mount

EDP Number	PART Number	CAPACITY Inches	MOUNT Style	DIMENSIONS		
				∅	L1	L2
L40160B	JK 06 R-3/8	1/64 - 1/4	3/8 - 24	1.339	2.480	2.756
L40161B	JK 08 R-3/8	1/32 - 5/16	3/8 - 24	1.457	2.835	3.071
L40162B	JK 08 R-1/2	1/32 - 5/16	1/2 - 20	1.457	2.835	3.071
L40165B	JK 10 R-3/8	1/32 - 3/8	3/8 - 24	1.457	2.835	3.071
L40439B	JK 10 R-3/8 **	1/32 - 3/8	3/8 - 24	1.457	2.835	3.071
L40166B	JK 10 R-1/2	1/32 - 3/8	1/2 - 20	1.457	2.835	3.071
L40440B	JK 10 R-1/2 **	1/32 - 3/8	1/2 - 20	1.457	2.835	3.071
L40171B	JK 13 R-3/8	1/16 - 1/2	3/8 - 24	1.575	2.992	3.268
L40443B	JK 13 R-3/8 **	1/16 - 1/2	3/8 - 24	1.575	2.992	3.268
L40444B	JK 13 R-1/2 **	1/16 - 1/2	1/2 - 20	1.575	2.992	3.268
L40175B	JK 16 R-1/2	1/8 - 5/8	1/2 - 20	2.047	3.740	4.134
L40176B	JK 16 R-5/8	1/8 - 5/8	5/8 - 16	2.047	3.740	4.134

**Retail packaging available upon request

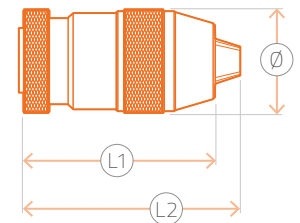

Jacobs Taper or
Threaded Mount

Taper Mount

EDP Number	PART Number	CAPACITY Inches	MOUNT Style	DIMENSIONS		
				∅	L1	L2
L40158B	JK 04 J-1	1/64 - 5/32	1JT	1.024	1.969	2.165
L40159B	JK 06 J-1	1/64 - 1/4	1JT	1.339	2.480	2.756
L40163B	JK 08 J-1	1/32 - 5/16	1JT	1.457	2.835	3.071
L40164B	JK 08 J-25	1/32 - 5/16	2JT	1.457	2.835	3.071
L40167B	JK 10 J-2	1/32 - 3/8	2JT	1.575	3.110	3.386
L40221B	JK 10 J-33	1/32 - 3/8	33JT	1.575	3.110	3.386
L40168B	JK 13 J-2	1/32 - 1/2	2JT	1.850	3.661	4.055
L40169B	JK 13 J-33	1/32 - 1/2	33JT	1.850	3.661	4.055
L40170B	JK 13 J-6	1/32 - 1/2	6JT	1.850	3.661	4.055
L40173B	JK 16 J-33	1/8 - 5/8	33JT	2.047	3.740	4.134
L40174B	JK 16 J-6	1/8 - 5/8	6JT	2.047	3.740	4.134
L40177B	JK 20 J-3	3/16 - 3/4	3JT	2.520	4.764	5.157

CBB

Super Ball-Bearing Drill Chuck with Key

- For industrial applications that require the toughest machining conditions
- Ball bearings reduce friction in the tightening mechanism and provide a better grip on the drill shaft.
- All CBB components are hardened and ground
- One-piece gear ring and sleeve eliminate the possibility of tooth breakage
- Jacobs® taper mount standard



CAPACITY
UP TO
1"



EDP	PART	CAPACITY	MOUNT	KEY	DIMENSIONS		
Number	Number	Inches	Style	Type	∅	L1	L2
L40072B	CBB-13 J3	1/32 - 1/2	3JT	K3	2.441	2.953	3.701
L40626B	CBB-13 J6	1/32 - 1/2	6JT	K3	2.441	2.953	3.701
L40073B	CBB-16 J3	1/16 - 5/8	3JT	K4	2.638	3.189	4.016
L40074B	CBB-19 J4	1/8 - 3/4	4JT	K4	2.953	3.898	4.921
L40075B	CBB-25 J5	13/64 - 1	5JT	K5	3.661	4.409	5.787

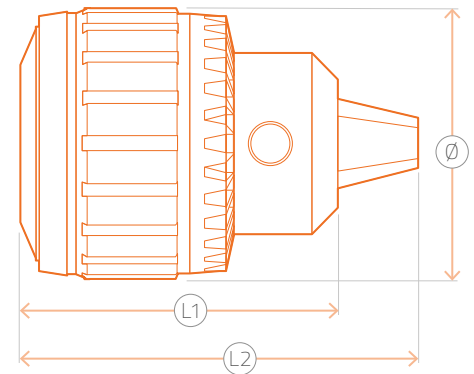

Jacobs Taper

**CAN'T FIND WHAT YOU'RE
LOOKING FOR? JUST ASK!**

ADDITIONAL CONFIGURATIONS INCLUDING
DIN MOUNTS AVAILABLE, INQUIRE AT
SALES@QTIMPORTS.COM



Performance Plain Bearing Drill Chuck with Key

- One-piece gear ring and sleeve eliminate the possibility of tooth breakage
- Jaws, gear ring and body are totally hardened for exceptional tool life
- Specially designed for stationary drilling, turning, milling and wood working machines.
- Available in Jacobs® taper or screw thread mounts



CAPACITY UP TO **3/4"**



Heavy Duty

EDP	PART	CAPACITY	MOUNT	KEY	DIMENSIONS		
Number	Number	Inches	Style	Type	∅	L1	L2
L40124B	CY-06 R-3/8 SP	1/64 - 1/4	3/8 - 24	CK4	1.456	2.007	2.480
L40125B	CY-10 R-1/2 SP	1/64 - 3/8	1/2 - 20	K34	1.692	2.086	2.677
L40131B	CY-10 J-2 SP	1/32 - 3/8	2JT	K34	1.693	2.165	2.677
L40116B	CYX-13 J-2	3/64 - 1/2	2JT	K3	2.087	2.717	3.504
L40117B	CYX-13 J-6	3/64 - 1/2	6JT	K3	2.087	2.717	3.504
L40118B	CYX-13 J-33	3/64 - 1/2	33JT	K3	2.087	2.717	3.504

Medium Duty

EDP	PART	CAPACITY	MOUNT	KEY	DIMENSIONS		
Number	Number	Inches	Style	Type	∅	L1	L2
L40137B	CY-04 R-5/16	1/32 - 5/32	5/16 - 24	K0	0.866	1.496	1.732
L40129B	CY-04 J-0	1/32 - 5/32	0JT	K0	0.866	1.142	1.417
L40138B	CY-06 R-3/8	1/32 - 1/4	3/8 - 24	CK4	1.260	1.654	2.047
L40140B	CY-10 R-3/8	1/32 - 3/8	3/8 - 24	K34	1.457	2.008	2.362
L40142B	CY-10 R-1/2	1/32 - 3/8	1/2 - 20	K34	1.457	2.008	2.362
L40132B	CY-10 J-1	1/32 - 3/8	1JT	K34	1.457	2.008	2.362
L40133B	CY-10 J-2	1/32 - 3/8	2JT	K34	1.457	2.008	2.362
L40144B	CY-13 R-3/8	3/64 - 1/2	3/8 - 24	K2	1.811	2.441	3.031
L40143B	CY-13 R-1/2	3/64 - 1/2	1/2 - 20	K2	1.811	2.441	3.031
L40145B	CY-13 R-5/8	3/64 - 1/2	5/8 - 16	K2	1.811	2.441	3.031
L40134B	CY-13 J-33	3/64 - 1/2	33JT	K2	1.811	2.441	3.031
L40136B	CY-13 J-33 KD1	3/64 - 1/2	33JT	K2	1.811	2.795	3.386
L40119B	CYX-13 J-33C3	3/64 - 1/2	33JT	K3	2.087	3.386	4.173
L40528B	CY-13 J-6	3/64 - 1/2	6JT	K2	1.811	2.440	3.031
L40126B	CY-16 R-1/2	1/16 - 5/8	1/2 - 20	K3	2.244	3.031	3.740
L40123B	CY-16 R-5/8	1/32 - 5/8	5/8 - 16	K3	2.244	3.031	3.740
L40531B	CY-16 J-33	1/32 - 5/8	33JT	K3	2.244	3.031	3.740
L40532B	CY-16 J-6	1/32 - 5/8	6JT	K3	2.244	3.031	3.740
L40113B	CY-16 J-3	1/32 - 5/8	3JT	K3	2.168	3.069	3.740
L40114B	CY-16 J-3 KD1	1/32 - 5/8	3JT	K3	2.244	3.346	4.016
L40115B	CY-16 J-3 PD2	1/32 - 5/8	3JT	K3	2.244	3.346	4.016
L40120B	CY-19 J-3	13/64 - 3/4	3JT	K4	2.559	3.346	4.331
L40121B	CY-19 J-3 KD1	13/64 - 3/4	3JT	K4	2.559	3.504	4.567
L40122B	CY-19 J-3 PD2	13/64 - 3/4	3JT	K4	2.559	3.504	4.567

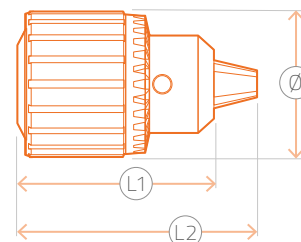

Jacobs Taper or Threaded Mount

- KD1** = POSITIVE DRIVE SLOT
- PD2** = PIN TYPE POSITIVE DRIVE
- C3** = LOCKING COLLAR

INOX Series: Stainless

Available in keyed and keyless models



- Manufactured from stainless steel to withstand chemical corrosion.
- Identified with special laser markings to hold up to the autoclave process.
- FGE keyless chucks have milled instead of knurled grip areas to ensure non-slip hand tightening free of sharp edges. Excellent choice for use when operating with rubber gloves.
- All FGE and GE drill chucks models are bead blasted with glass balls and have a passivation treatment by an electro-polishing technique. This adds additional protection against all types of corrosion, eliminates undesirable residual contaminants and improves the finish of the surface profile.
- For the insertion of nails, screws, pins and other medical fasteners, all chucks come with a through hole.
- Special designs, sizes and mounts for all types of applications are available upon request.
- Lubricated with a special grease for food and medical applications.



**CAN'T FIND WHAT YOU'RE
LOOKING FOR? JUST ASK!**

**ADDITIONAL CONFIGURATIONS AVAILABLE,
INQUIRE AT SALES@QTIMPORTS.COM**

SP

Threaded Mount

KEYLESS



EDP Number	PART Number	CAPACITY Inches	MOUNT Style	DIMENSIONS		
				∅	L1	L2
L40695B	SP-03 R-3/8 FGE	.012 - .125	3/8 - 24	1.043	1.752	1.894
L14717B	SP-03 R-3/8 FGE-S	.012 - .125	3/8 - 24	1.043	1.751	1.893
L40706B	SP-03 R-5/16 FGE	.012 - .125	5/16 - 24	1.043	1.751	1.893
L40751B	SP-07 R-3/8 FGE-C	.012 - .291	3/8 - 24	1.181	2.205	2.470
L40707B	SP-07 R-5/16 FGE-C	.012 - .291	5/16 - 24	1.181	2.468	2.470

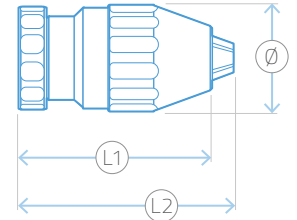

Jacobs Taper or Threaded Mount

Tapered Mount

EDP Number	PART Number	CAPACITY Inches	MOUNT Style	DIMENSIONS		
				∅	L1	L2
L40704B	SP-15 J0 FGE	.008 - .059	OJT	0.779	1.397	1.468
L40705B	SP-03 J0 FGE	.012 - .125	OJT	1.043	1.751	1.893
L40750B	SP-07 J1 FGE-C	.012 - .291	1JT	1.181	2.283	2.549

C = COMPACT VERSION

FGE = NOSE & COLLAR HAVE MILLED SECTIONS, BEAD BLASTED

GE = BEAD BLASTED SLEEVE

CSS

Threaded Mount

KEYED



EDP Number	PART Number	CAPACITY Inches	MOUNT Style	KEY Type	DIMENSIONS		
					∅	L1	L2
L13967B	CSS-04 R-5/16 GE	.020 - .156	5/16 - 24	K0M	0.866	1.181	1.366
L14720B	CSS-06 R-3/8 GE DS	.020 - .291	3/8 - 24	K1M	1.118	1.575	1.980
L40699B	CSS-06 R-5/16 GE-DS	.020 - .291	5/16 - 24	K1M	1.118	1.575	1.980

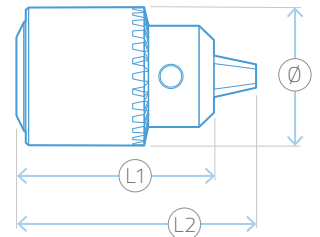

Jacobs Taper or Threaded Mount

Tapered Mount

EDP Number	PART Number	CAPACITY Inches	MOUNT Style	KEY Type	DIMENSIONS		
					∅	L1	L2
L40680B	CSS-04 J0 GE	.020 - .156	OJT	K0M	0.866	1.102	1.378
L40696B	CSS-06 J1 GE-DS	.020 - .291	1JT	K1M	1.118	1.575	1.980

Chucks with a capacity up to 7.4mm/0.291" are ideal to hold Zimmer accessories.

Arbors for Drill Chucks

Lambrich arbors are Completely hardened and precision ground to ensure a close fit for maximum concentricity.



Morse Taper to Jacobs® Taper

EDP Number	Part Number	Morse Taper	Jacobs® Taper
LEJ010B	E-J0/1	1	0
LEJ011B	E-J1/1	1	1
LEJ012B	E-J2/1	1	2
LEJ013B	E-J3/1	1	3
LEJ016B	E-J6/1	1	6
LEJ133B	E-J33/1	1	33
LEJ021B	E-J1/2	2	1
LEJ022B	E-J2/2	2	2
LEJ023B	E-J3/2	2	3
LEJ026B	E-J6/2	2	6
LEJ233B	E-J33/2	2	33
LEJ031B	E-J1/3	3	1
LEJ032B	E-J2/3	3	2
LEJ033B	E-J3/3	3	3
LEJ036B	E-J6/3	3	6
LEJ333B	E-J33/3	3	33
LEJ034B	E-J4/3	3	4
LEJ035B	E-J5/3	3	5
LEJ042B	E-J2/4	4	2
LEJ043B	E-J3/4	4	3
LEJ046B	E-J6/4	4	6
LEJ433B	E-J33/4	4	33
LEJ044B	E-J4/4	4	4
LEJ045B	E-J5/4	4	5
LEJ055B	E-J5/5	5	5



Morse Taper to Threaded Mount

EDP Number	Part Number	Threaded Mount	Morse Taper
L40585B	E-MT2-3/8	3/8-24	2
L40586B	E-MT2-1/2	1/2-20	2
L40587B	E-MT2-5/8	5/8-16	2



Straight Shank to Jacobs® Taper

EDP Number	Part Number	Straight Shank	Jacobs® Taper
L40588B	E-1/2-J0	1/2	0
L40589B	E-1/2-J1	1/2	1
L40590B	E-1/2-J2	1/2	2
L40591B	E-1/2-J3	1/2	3
L40592B	E-1/2-J33	1/2	33
L40593B	E-1/2-J4	1/2	4
L40594B	E-1/2-J6	1/2	6
L40595B	E-5/8-J1	5/8	1
L40596B	E-5/8-J2	5/8	2
L40597B	E-5/8-J3	5/8	3
L40598B	E-5/8-J33	5/8	33
L40599B	E-5/8-J4	5/8	4
L40600B	E-5/8-J6	5/8	6
L40601B	E-3/4-J2	3/4	2
L40602B	E-3/4-J3	3/4	3
L40603B	E-3/4-J33	3/4	33
L40604B	E-3/4-J4	3/4	4
L40605B	E-3/4-J6	3/4	6
L40606B	E-1-J2	1	2
L40607B	E-1-J3	1	3
L40608B	E-1-J33	1	33
L40609B	E-1-J4	1	4
L40610B	E-1-J6	1	6
L40611B	E-1-1/2-J3	1-1/2	3
L40612B	E-1-1/2-J4	1-1/2	4



R-8 Shank to Jacobs® Taper

EDP Number	Part Number	Jacobs® Taper
L40579B	E-R8-J1	1
L40580B	E-R8-J2	2
L40581B	E-R8-J3	3
L40582B	E-R8-J33	33
L40583B	E-R8-J4	4
L40584B	E-R8-J6	6

CAN'T FIND WHAT YOU'RE LOOKING FOR? JUST ASK!

ADDITIONAL CONFIGURATIONS AVAILABLE, INQUIRE AT SALES@QTIMPORTS.COM

Drill Sleeves

Completely hardened and ground externally and internally to ensure a tight fit.



Drill Sleeves DIN-2185

EDP Number	Part Number	Morse Taper	
		Outside	Inside
LCR021B	CR-2 x 1	2	1
LCR031B	CR-3 x 1	3	1
LCR032B	CR-3 x 2	3	2
LCR041B	CR-4 x 1	4	1
LCR042B	CR-4 x 2	4	2
LCR043B	CR-4 x 3	4	3
LCR051B	CR-5 x 1	5	1
LCR052B	CR-5 x 2	5	2
LCR053B	CR-5 x 3	5	3
LCR054B	CR-5 x 4	5	4
L40414B	CR-6 x 2	6	2
L40415B	CR-6 x 3	6	3
L40416B	CR-6 x 4	6	4
L40417B	CR-6 x 5	6	5

Ejecting Drift

Assists in ejecting Morse taper arbors from drill sleeves or machine spindles

- Tempered steel



EDP No.	Part No.	Morse Taper
L40418B	CE 1-2	1 & 2
L40419B	CE 2-3	2 & 3
L40420B	CE 3-4	3 & 4
L40421B	CE 4-5	4 & 5
L40422B	CE 5-6	5 & 6

Keys

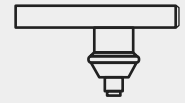

CSS	Chuck EDP	Part No.	Key EDP
	CSS-04	K0M	L40235A
	CSS-06	K1M	L40233A

CBB	Chuck EDP	Part No.	Key EDP
	CBB-08	K30	L40088A
	CBB-10	K32	L40089A
	CBB-13	K3	L40090A
	CBB-16	K4	L40091A
	CBB-19	K4	L40091A
	CBB-25	K5	L40093A

CY	Chuck EDP	Part No.	Key EDP
	CY-04	K0	L40535A
	CY-06	CK4	L40578A
	CY-06 SP	K34	L40578A
	CY-10	K34	L40537A
	CY-10 SP	K34	L40537A
	CY-13	K2	L40538A
	CYX-13	K3	L40090A
	CY-16	K3	L40090A
	CY-19	K4	L40091A

Wrenches

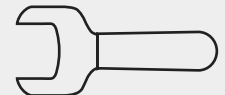

NPU	Chuck EDP	Part No.	Wrench EDP
	NPU-08	0812	L30622A
	NPU-13	1312	L40066A
	NPU-16	1612	L40067A

JKT	Chuck EDP	Part No.	Wrench EDP
	JKT-65	0612	L31123A
	JKT-80	0812	L30622A
	JKT-100	1012	L40065A
	JKT-130	1312	L40066A
	JKT-160	1612	L40067A

JK-Solid	Chuck EDP	Part No.	Wrench EDP
	JK-08	0812	L30622A
	JK-10	1012	L40065A
	JK-13	1312	L40066A
	JK-16	1612	L40067A

Hex Keys

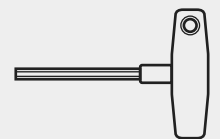

HEXA	Chuck EDP	Part No.	Key EDP
	HX-10	HX-10	L40068A
	HX-13	HX-13-16	L40069A
	HX-16	HX-13-16	L40069A

Live Centers

Live Centers for Accurate Work Holding in Conventional or CNC Lathes

- Llambrich revolving lathe centers are of high precision
- Capable of bearing up to 2,200 lbs workload and speeds of up to 5,000 rpm
- Fully hardened and precision ground
- Standard or extended nose configurations
- Maintenance free

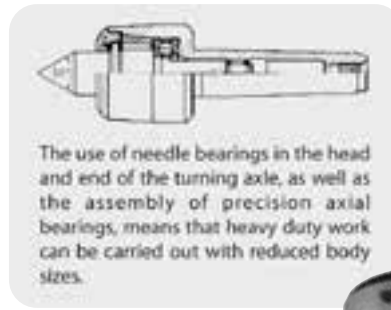

★ CERTIFIED ★
ACCURACY
MAX. RUNOUT
UP TO
0.00012"

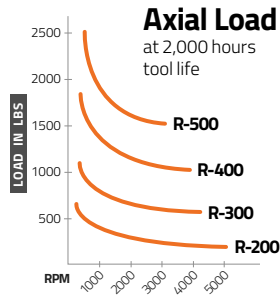
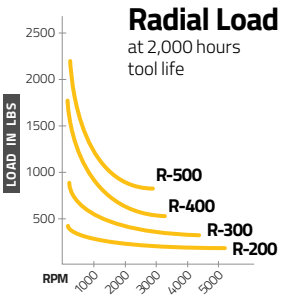

Max. Runout by Model

R-200	0.00012"
R-300	0.00012"
R-400	0.00012"
R-500	0.00016"

Model N

For a wide range of general turning work.

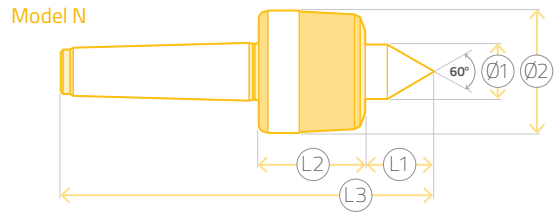

EDP	PART	MORSE	LOAD FACTOR	MAX RUNOUT	DIMENSIONS					
Number	Number	TAPER	lbs		Ø1	Ø2	Ø3	L1	L2	L3
LGN200B	R-200-N	2	400	0.00012"	0.709	1.654	--	0.945	1.378	5.039
LGN300B	R-300-N	3	890	0.00012"	0.866	1.929	--	1.142	1.850	6.417
LGN400B	R-400-N	4	1,765	0.00012"	1.181	2.480	--	1.378	2.047	7.717
LGN500B	R-500-N	5	3,860	0.00016"	1.299	3.346	--	1.890	2.520	9.843

Model C

Increases tool clearance and operator visibility for work on small parts or machining close to workpiece end.

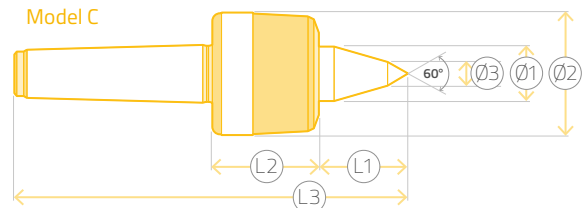

EDP	PART	MORSE	LOAD FACTOR	MAX RUNOUT	DIMENSIONS					
Number	Number	TAPER	lbs		Ø1	Ø2	Ø3	L1	L2	L3
LGC300B	R-300-C	3	890	0.00012"	0.866	1.929	0.394	1.496	1.850	6.850
LGC400B	R-400-C	4	1,765	0.00012"	1.181	2.480	0.433	1.811	2.047	8.150
LGC500B	R-500-C	5	3,860	0.00016"	1.299	3.346	0.709	2.520	2.520	10.472

Small Diameter Live Centers

Small Casing Diameter

- Small diameter for optimum accessibility
- Additional bearings to compensate axial load
- Morse tapers hardened and ground
- High concentricity
- Lubricated for life
- Maintenance free

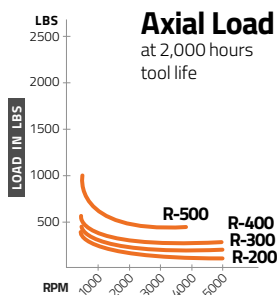
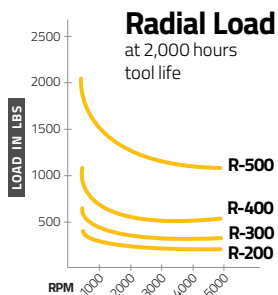

Max. Runout by Model

R-200	0.00019"
R-300	0.00019"
R-400	0.00019"
R-500	0.00031"



Model RN

For a wide range of general turning work.

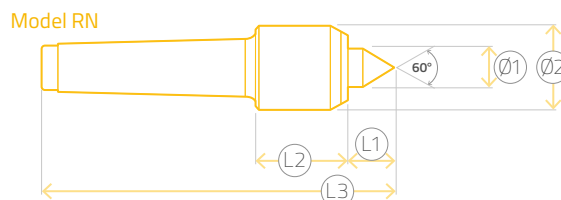

EDP Number	PART Number	MORSE TAPER	LOAD FACTOR lbs	MAX RUNOUT	DIMENSIONS					
					Ø1	Ø2	Ø3	L1	L2	L3
L40548B	R-200-RN	2	440	0.00019"	0.591	1.260	--	0.787	1.535	5.000
L40549B	R-300-RN	3	880	0.00019"	0.591	1.339	--	0.787	1.575	5.709
L40550B	R-400-RN	4	1765	0.00019"	0.787	1.693	--	1.024	1.654	7.087
L40551B	R-500-RN	5	2645	0.00031"	1.181	2.283	--	1.457	2.362	9.252

Model RC

Increases tool clearance and operator visibility for work on small parts or machining close to workpiece end.

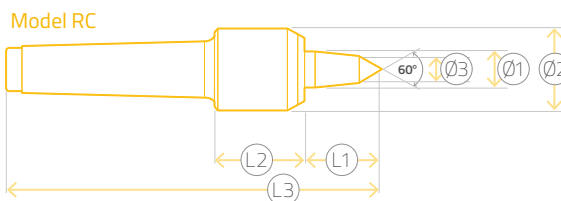

EDP Number	PART Number	MORSE TAPER	LOAD FACTOR lbs	MAX RUNOUT	DIMENSIONS					
					Ø1	Ø2	Ø3	L1	L2	L3
L40552B	R-200-RC	2	330	0.00019"	0.591	1.260	0.315	1.181	1.535	5.394
L40553B	R-300-RC	3	660	0.00019"	0.591	1.339	0.315	1.181	1.575	6.102
L40554B	R-400-RC	4	1545	0.00019"	0.787	1.693	0.394	1.417	1.654	7.480
L40555B	R-500-RC	5	2200	0.00031"	1.181	2.283	0.472	2.008	2.362	9.646

Model RE

Maximum tool clearance and operator visibility for work on small parts or machining close to workpiece end.

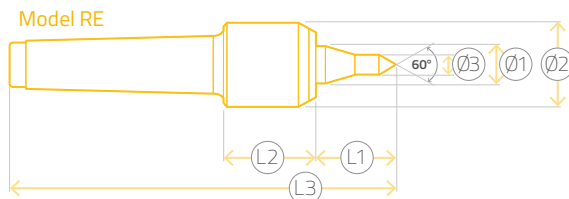

EDP Number	PART Number	MORSE TAPER	LOAD FACTOR lbs	MAX RUNOUT	DIMENSIONS					
					Ø1	Ø2	Ø3	L1	L2	L3
L40556B	R-200-RE	2	285	0.00019"	0.591	1.260	0.236	1.181	1.535	5.394
L40557B	R-300-RE	3	615	0.00019"	0.591	1.339	0.315	1.220	1.575	6.102
L40558B	R-400-RE	4	1435	0.00019"	0.787	1.693	0.394	1.496	1.654	7.480
L40559B	R-500-RE	5	2050	0.00031"	1.181	2.283	0.472	1.929	2.362	9.646



Conversion Chart



Hexa: page 6

Llambrich® EDP	Llambrich® Part Number	Jacobs® Part Number	Albrecht® Part Number	LFA® Part Number	Rohm® Part Number
L40016B	HX-13 CA-40	-	KL130 - CAT40	-	-
L40020B	HX-16 CA-40	-	KL160 - CAT40	-	-
L40024B	HX-16 CA-50	-	KL160 - CAT50	-	-
L40008B	HX-13 BT-40	-	KL130 - BT40	-	-
L40012B	HX-16 BT-40	-	KL160 - BT40	-	-
L40014B	HX-16 BT-50	-	KL160 - BT50	-	-
L40021B	HX-13 CA-40/R	-	KL130 - CAT40C	-	-
L40025B	HX-16 CA-40/R	-	KL160 - CAT40C	-	-
L40027B	HX-16 CA-50/R	-	KL160 - CAT50C	-	-
L40005B	HX-13 BT-40/R	-	KL130 - BT40C	-	-
L40009B	HX-16 BT-40/R	-	KL160 - BT40C	-	-
L40015B	HX-16 BT-50/R	-	KL160 - BT50C	-	-
L40029B	HX-13 HSK-63 /R	-	KL130-HSK63	-	-
L40031B	HX-13 HSK-100/R	-	KL130-HSK100	-	-
L40033B	HX-16 HSK-63 /R	-	KL160-HSK63	-	-
L40035B	HX-16 HSK-100/R	-	KL160-HSK100	-	-
L40036B	HX-13 VDI-30	-	KL130-VDI30C	-	-
L40037B	HX-13 VDI-40	-	KL130-VDI40C	-	-
L40039B	HX-16 VDI-30	-	KL160-VDI30C	-	-
L40040B	HX-16 VDI-40	-	KL160-VDI40C	-	-



JK Solid: page 8

Llambrich® EDP	Llambrich® Part Number	Jacobs® Part Number	Albrecht® Part Number	LFA® Part Number	Rohm® Part Number
L31411B	JK-130 R-8	JK130-R8	CP130-R8	71052	-
L31416B	JK-160 R-8	JK160-R8	CP160-R8	81052	-
L31406B	JK-08 MT2	JK80-MT2	-	-	-
L31407B	JK-10 MT2	JK100-MT2	-	-	-
L31408B	JK-13 MT2	JK130-MT2	CP130-2MT	-	-
L31409B	JK-13 MT3	JK130-MT3	CP130-3MT	-	-
L31410B	JK-13 MT4	JK130-MT4	CP130-4MT	-	-
L31413B	JK-16 MT2	JK160-MT2	CP160-2MT	-	-
L31414B	JK-16 MT3	JK160-MT3	CP160-3MT	-	-
L31415B	JK-16 MT4	JK160-MT4	CP160-4MT	-	-
L31412B	JK-130 5/8	JK130-5/8	CP130-5/8	-	-



JKP: page 9

Llambrich® EDP	Llambrich® Part Number	Jacobs® Part Number	Albrecht® Part Number	LFA® Part Number	Rohm® Part Number
L31126B	JKP-30 J-0	JKP 30-J0	C30-J0	-	-
L31127B	JKP-30 J-1	JKP 30-J1	C30-J1	-	-
L31128B	JKP-30 R-5/16	JKP 30-5/16	CT30-5/16	-	-
L31121B	JKP-65 J-1	JKP 65-J1	C65-J1	-	871005
L40002B	JKP-80 J-1	JKP 80-J1	-	-	871007
L9679B	JKP-80 J-2S	JKP 80-J2S	C80-J2	-	-
L9681B	JKP-100 J-2	JKP 100-J2	C100-J2	72SA-J2	871010
L9680B	JKP-100 J-33	JKP 100-J33	C100-J33	-	871011
L9683B	JKP-130 J-2	JKP 130-J2	C130-J2	-	871013
L9682B	JKP-130 J-33	JKP 130-J33	C130-J33	73SA-J33	871014
L9684B	JKP-130 J-6	JKP 130-J6	C130-J6	73SA-J6	871015
L40003B	JKP-160 J-33	JKP160-J33	-	-	-
L9685B	JKP-160 J-6	JKP 160-J6	C160-J6	74SA-J6	871018



JKT: page 10

Llambrich® EDP	Llambrich® Part Number	Jacobs® Part Number	Albrecht® Part Number	LFA® Part Number	Rohm® Part Number
L31122B	JKT-65 J-1	JKT 65-J1	-	-	-
L30526B	JKT-80 J-2S	JKT 80-J2S	-	-	-
L30533B	JKT-100 J-2	JKT 100-J2	-	-	-
L30523B	JKT-100 J-33	JKT 100-J33	-	-	-
L30527B	JKT-13- J-2	JKT 130-J2	-	-	-
L30528B	JKT-130 J-33	JKT 130-J33	-	73ST-J33	-
L30529B	JKT-130 J-6	JKT 130-J6	-	73ST-J6	-
L30530B	JKT-160 J-6	JKT 160-J6	-	-	-

CAN'T FIND WHAT YOU'RE LOOKING FOR? JUST ASK!

ADDITIONAL CONFIGURATIONS INCLUDING

DIN MOUNTS AVAILABLE, INQUIRE AT

SALES@QTIMPORTS.COM



JK-Industrial: page 11

Llambrich® EDP	Llambrich® Part Number	Jacobs® Part Number	Albrecht® Part Number	LFA® Part Number	Rohm® Part Number
L40158B	JK 04 J-1	-	-	-	-
L40159B	JK 06 J-1	-	-	-	-
L41060B	JK 06 R-3/8	-	-	-	-
L40161B	JK 08 R-3/8	JK 80 3/8	-	-	871034
L40162B	JK 08 R-1/2	JK 80 1/2	-	-	871035
L40163B	JK 08 J-1	JK 80 J1	-	61BA-J1	871033
L40164B	JK 08 J-2S	JK 80 J2	-	-	-
L40165B	JK 10 R-3/8	JK 100 3/8	-	520-3/8-24	871044
L40166B	JK 10 R-1/2	JK 100 1/2	-	520-1/2-20	871045
L40167B	JK 10 J-2	JK100 J2	-	62A-J2	871042
L40221B	JK 10 J-33	JK 100 J33	-	62A-J33	871043
L40168B	JK 13 J-2	JK 130 J2	-	-	871048
L40169B	JK 13 J-33	JK 130 J33	-	63A-J33	871053
L40170B	JK 13 J-6	JK 130 J6	-	63A-J6	871054
L40171B	JK 13 R-3/8	JK 130 3/8	-	5322A CAR	871049
L40172B	JK 13 R-1/2	JK 130 1/2	-	5322A CAR	871050
L40173B	JK 16 J-33	JK 160 J33	-	64A-J33	871060
L40174B	JK 16 J-6	JK 160 J6	-	64A-J6	871066
L40175B	JK 16 R-1/2	JK 160 1/2	-	-	871062
L40176B	JK 16 R-5/8	JK 160 5/8	-	-	871063
L40177B	JK 20 J-3	JK 200 J3	-	-	-



SP: page 14

Llambrich® EDP	Llambrich® Part Number	Jacobs® Part Number
L40000	SP-03 R-3/8 SS	OM KL-0JT
L40001	SP-06 R-3/8 SS	1M KL-1JT



CSS: page 15

Llambrich® EDP	Llambrich® Part Number	Jacobs® Part Number
L40680B	CSS-04 JO GE	OM
L13967B	CSS-04 R-5/16 GE	OBM 5/16
L40696B	CSS-06 J1 GE-DS	1M
L14720B	CSS-06 R-3/8 GE-DS	1BM 3/8
L40699B	CSS-06 R-5/16 GE-DS	1BM 5/16



CBB: page 12

Llambrich® EDP	Llambrich® Part Number	Jacobs® Part Number	Albrecht® Part Number	LFA® Part Number	Rohm® Part Number
L40070B	CBB-08 J2	8-1/2N	-	81BS-13A-J2	-
L40071B	CBB-10 J2	11N	-	82BS-5A-J2	-
L40072B	CBB-13 J3	14N	-	83S-6A-J3	BB13-3(215000)
L40626B	CBB-13 J6	-	-	-	-
L40073B	CBB-16 J3	16N	-	84S-6A-J3	BB16-3(215001)
L40074B	CBB-19 J4	18N	-	85S-9A-J4	-
L40075B	CBB-25 J5	20N	-	85BS-9A-J4	BB26-5(2150003)



CY: page 13

Llambrich® EDP	Llambrich® Part Number	Jacobs® Part Number	Albrecht® Part Number	LFA® Part Number	Rohm® Part Number
L40129B	CY-04 J-0	0	-	80-0A	RO-0 (72807)
L40130B	CY-06 J-1	1A	-	81-1A-J1	R1-1 (666537)
L40132B	CY-10 J-1	31-01	-	-	R8-1(72662)
L40133B	CY-10 J-2	31-02	-	-	R2-2 (666567)
L40131B	CY-10 J-2SP	2A	-	-	-
L40134B	CY-13 J-33	33	-	43B-5A-J33	R3-33(666572)
L40528B	CY-13 J-6	-	-	-	-
L40116B	CYX-13 J-2	34-02	-	43-6A-J2	R3-2 (666571)
L40118B	CYX-13 J-33	34-33	-	43-6A-J33	-
L40117B	CYX-13 J-6	34-06	-	43-6A-J6	R3-6 (666573)
L40531B	CY-16 J-33	-	-	-	-
L40532B	CY-16 J-6	-	-	-	-
L40113B	CY-16 J-33	3A	-	84-6A-J3	R4-3 (666579)
L40120B	CY-19 J-3	36	-	45-6A-J3	R5-3 (72833)
L40534B	CY-19 J-4	-	-	-	-
L40137B	CY-04 R-5/16	OB 5/16	-	-	-
L40138B	CY-06 R-3/8	1B 3/8	-	81-1B-3/8-24	-
L40124B	CY-06 R-3/8SP	7BA 3/8	-	-	R1-38TH (666563)
L40140B	CY-10 R-3/8	41BA 3/8	-	-	-
L40139B	CY-10 R-3/8SP	2BA 3/8	-	82-2B-3/8-24	-
L40142B	CY-10 R-1/2	41BA 1/2	-	-	-
L40125B	CY-10 R-1/2SP	32BA 1/2	-	82B-5B-1/2-20	-
L40144B	CY-13 R-3/8	33BA 3/8	-	43B-5B-3/8-24	R3-38TH (666574)
L40143B	CY-13 R-1/2	33BA 1/2	-	43B-5B-1/2-2-	R3-12TH (666575)
L40145B	CY-13 R-5/8	33BA 5/8	-	43B-5B-5/8-16	-
L40126B	CY-16 R-1/2	35B 1/2	-	-	-
L40123B	CY-16 R-5/8	3B 5/8	-	84-6B-5/8-16	-
L40128B	CY-19 R-5/8	36B 5/8	-	45-65-5/8-16	-
L40127B	CY-19 R-3/4	36B 3/4	-	45-6B-3/4-16	-

Parts of a Drill Chuck

Mounting Systems

Taper
Thread
Straight Hole

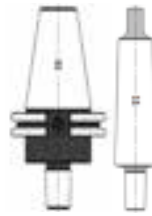
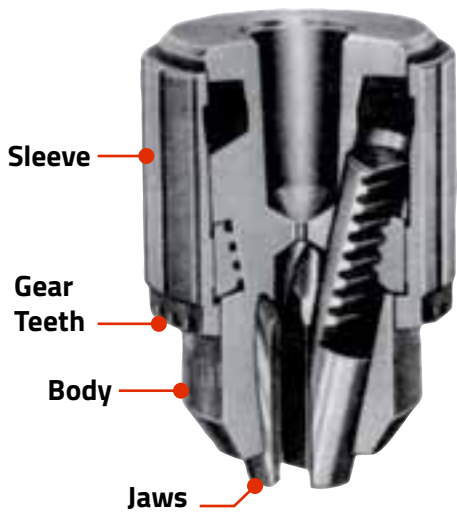

Arbor

Chuck mounting devices used to adapt standardized chuck mounts to various machine spindle tapers.



Sleeve

Adapter for arbors when the machine spindle requires a larger taper than is available on the arbor.

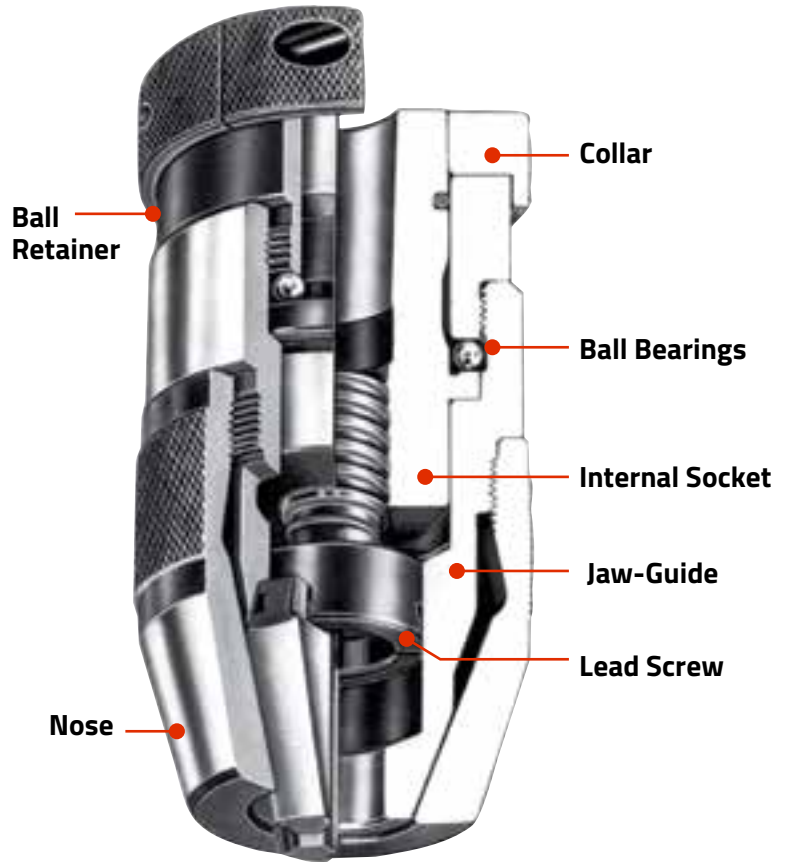

Mounting & Removing Chucks



Threaded Spindle Tools

Unplug drill or disconnect battery pack. Open jaws of existing chuck completely. If present, remove left-hand thread screw from inside chuck and save for re-use.

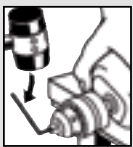

Insert hex-type wrench into chuck body and tighten jaws on wrench. Strike wrench counterclockwise with mallet to free and unscrew chuck.



Screw new chuck onto spindle (clockwise). Insert hex-type wrench in jaws and tighten jaws on wrench. Strike wrench clockwise with mallet several times.



Tapered Shank Arbors

Clean both tapers of all grease and grit. With the jaws retracted into the chuck and with the chuck nose resting on a wooden bench, strike the tang of the arbor lightly to seal it into the chuck.

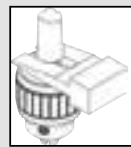

Removing the Arbor

Insert wedge between the back of the chuck and the shoulder of the arbor.

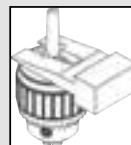

If the mounting taper of the arbor does not provide a shoulder, a cross hole should be drilled through the neck of the arbor and a cross pin inserted. Then the wedge can be used between the chuck back and the cross pin.

Types of Drill Chucks

Type Well Suited for:

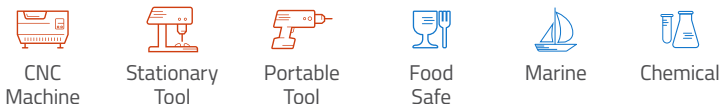

KEYED



CNC Precision with Integrated Shank



Ideal for CNC machines. Uses a Hexagonal Key Lock System. Short design, maximum concentricity, max. run-out .0012" or better sometimes supplied with a certification, high clamping forces, over 75 ft/lbs, and optional through coolant and balance. Permits clockwise and counterclockwise turning. For use in high speed CNC equipment for milling, drilling, reaming and tapping.



Super Ball Bearing



Keyed chucks require a key for tightening or loosening, and permit clockwise and counterclockwise turning. The Super Ball Bearing Chucks are equipped with ball bearings to reduce friction in the tightening mechanism and provide a better grip on the drill. Used for industrial applications that require the toughest machining conditions, where high accuracy drilling is not a must. Available with tapered mounts only (Jacobs®).



Plain Bearing



Equipped with one-piece gearing and sleeve that reduces the possibility of teeth breaking. Used for stationary drilling, turning, milling and wood working machines. For medium duty industrial use, available with threaded mount for hand held drilling machines and with tapered mounts for stationary drilling machines where run-out is not a must.



Stainless Steel



Manufactured out of stainless steel. For use in the food, marine, chemical, medical and dental industries, where tools must be sterilized or resistant to environmental conditions. Same design as a Plain Bearing chuck, but in stainless steel.

KEYLESS



CNC Precision with Integrated Shank



Ideal for CNC machines with applications requiring clockwise turning only as it has a self-tightening feature. Compact construction, maximum connection rigidity, higher precision (TIR .0016" or better, certified by some producers). For use on CNC machine centers, milling and turning machines.



High Precision, High Torque



A self-tightening feature causes the chuck to grip tighter as more torque is applied. Permits clockwise turning only. Automatic fitting for efficient, fast change tools. Minimum run-out for accurate hole sizing, sometimes certified by the producer. For high accuracy drill presses, jig borers, milling machines and production drilling equipment, CNC's included. Also available with through hole for EDM machines. High Torque versions can include a wrench for increased clamping force to resist tool loosening on high speed machines with instant spindle stop.



Medium Duty Applications



Same self-tightening feature as High Precision or High Torque chucks, but with wider run-outs (about .006"). Automatic fitting for efficient, fast change tools. For medium duty industrial use, available with threaded mount for hand held drilling machines and with tapered mounts for stationary drilling machines. Clockwise turning only.



Stainless Steel



Manufactured out of stainless steel. High precision and selftightening design. For use in the food, marine, chemical, medical and dental industries, where tools must be sterilized or resistant to environmental conditions. Clockwise turning only.

LLAMBRICHUSA

The World's Most Complete Industrial Drill Chuck Offering



QTI is committed to providing our supply channel partners and end user customers the best drilling and tapping products in the world. If you have any suggestions on how we can do better, please don't hesitate to contact me!

-Joshua Nourse, President

**DIDN'T FIND WHAT YOU'RE
LOOKING FOR? JUST ASK!**

ADDITIONAL CONFIGURATIONS INCLUDING

DIN MOUNTS AVAILABLE, INQUIRE AT

SALES@QTIMPORTS.COM

www.qtimports.com

sales@qtimports.com

(220) 666-0911

601 Pittsburgh Avenue

Mount Vernon, OH 43050

llambrichusa.com