

CATALOGUE & TECHNICAL GUIDE 2015



TOOLING SYSTEMS

Alphanumeric index	3-5
Catalogue presentation	7-8
Product overview	Monobloc and Graflex® holders	9-12
	Combimaster holders	13
	Graflex® Modular System	14
	Additional equipment	15-16
	Shrinkfit devices	17
General guide	Quality	18
	Balancing	19-20
	Code key	21
	Taper norms	22-25
	Front end types	26-49
Monobloc holders	HSK-A holders	50-78
	HSK-E holders	79-85
	DIN 69871 holders	86-114
	BT JIS holders	115-148
Combimaster holders	Guide	149-151
	Arbors	152-158
	Intermediates	159-160
	Adapters	161-164
	Shrinkfit holders	165
Graflex® Modular System	Guide	166-172
	Arbors	173-181
	Intermediates	182-188
	Tool holders	189-210
	Connection accessories and spare parts	211-212
Seco-Capto™	Range presentation	213
	Overview	214-215
	Instructions	216
	Code keys	217
	Basic arbors	218-237
	Intermediates	238-245
	Tool holders	246-277
Additional equipment	Guide	278-286
	HSK coolant tubes, tube spanners and sealing plugs	287
	Pull studs	288-292
	Spare sealing plugs for ADB tapers	293
	Shrinkfit holders	294
	Reduction sleeves, control gauges for hydraulic chucks	295-296
	ER collets standard and high precision	297-303
	ER sealing rings	304
	OZ collets	305
	Tapping chucks for synchronized tapping	306-307
	ER tapping collets with square drive	308
	ER tapping sealing rings	309
	Tapping chucks with axial compensation	310
	Quick change tap adapters	311-312

Guide
HSK -A & E
DIN
BT
Combimaster
Graflex®
Seco-Capto™
Additional equipment
Shrinkfit devices

	Assembly support Toolboy	313
	HSK locking units and flange mounts, TF	314-321
Shrinkfit devices	Guide	322-330
	Easyshrink 15 and Easyshrink 20 devices	331-333
	Accessories and Spare parts	334-337
SMG	338-349
Declaration of conformity	350-352

0			
01B5875	304	
02E93	287	
03E93	287	
03H	211	
05F5832	295	
05R	336	
2			
20E93	287	
24H5095	314	
3			
3920	309	
3925	309	
393.14	308	
5			
5450	301	
5672	297-300	
5880	302-303	
5883B	305	
9			
90F	211	
90M	211	
950A	293	
B			
BC			
5821	163	
BD			
5801	294	
5820	161	
5821	161	
5822	161	
5867	307	
BM			
5603	195	
5672	196	
5675	198	
5820	164	
6100	205	
6101	206	
BR1	315	
BR2	316	
BR3	317	
BS			
5603	165	
5820	159-160	
BSM	207-210	
BW			
5821	162	
5867	306	
C			
C.-390.00	236-237	
C.-390.140	222-223	
C.-390.272	224-225	
C.-390.369	230-231	
C.-390.410	218-219	
C.-390.411	220-221	
C.-390.540	226-227	
C.-390.55	228-229	
C.-390.555	232-233	
C.-390.558	232-233	
C.-390.58	228-229	
C.-390.605	234-235	
C.-391.01	238-239, 242-243	
C.-391.02	240-241, 244-245	
C.-391.0401	276	
C.-391.0552	249	
C.-391.0584	253-254	
C.-391.20	251-252	
C.-391.21	255-256	
C.-391.27	257-258	
C.-391.5524	248	
C.-391.5525	248	
C.-391.5545	246	
C.-391.5555	247	
C.-391.5556	247	
C.-391.5600	261	
C.-391.5600P	262	
C.-391.5603	259-260	
C.-391.5657	250	
C.-391.5672	266	
C.-391.5675	267-268	
C.-391.5820	275	
C.-391.5834	264-265	
C.-391.5835	263	
C.-391.5867	269	
C.-391.60	270-271	
C.-391.61	272-273	
C.-391.K820	274	
C.-391.K821	274	
CA5832	296	
E			
E3214			
5600	132	
5600P	134	
E3216			
5600	132	
5600P	134	
E3414			
5023	147	
5085	142	
5525	117	
5545	115	
5555	116	
5556	116	
5600	130	
5600P	133	
5603	127-128	
5672	136	
5675	140	
5801	135	
5820	158	
5821	158	
5834	138	
5835	137	
584	122	
5842	125	
5865	145	
5873	141	
K820	157	
K821	157	

E3416				E3476	
5023	147			5801	101
5085	142			5820	156
5524	118			5821	156
5525	118			E3478	
5545	115			5545	86
5555	116			5820	156
5556	116			5842	95
5600	131			E4040	
5600P	133			552	119
5603	129			5603	126
5672	136			5672	136
5675	140			5675	139
5820	158			5867	143
5834	138			E4041	
5835	137			552	119
584	123-124			5657	121
5842	125			5675	140
5865	145			586	148
5873	141			5867	143
K820	157			E4469	
K821	157			552	90
E3469				5657	92
5023	113			5675	105
5085	107			586	114
5524	88			5867	108
5525	88			E4471	
5545	86			5095	112
5555	87			543	111
5556	87			552	90
5600	98			5657	92
5600P	100			569	91
5603	96			586	114
5672	102			5867	108
5675	105			E5766	
5834	104			543	146
5835	103			552	119
584	93			5657	121
5842	95			569	120
5865	110			5867	143
5873	106			E9301	
K820	155			5675	71
K821	155			E9302	
E3471				5023	77
5023	113			5603	60
5085	107			5672	68
5525	89			5675	71
5555	87			5801	67
5556	87			5820	153
5600	99			E9304	
5600P	100			5023	77
5603	97			5085	72
5672	102			552	54
5675	105			5524	52
5834	104			5525	52
5835	103			5545	50
584	94			5555	51
5842	95			5556	51
5865	110			5600	64
5873	106			5600P	66
K820	155			5603	60-61
K821	155			5657	57

5672.....	68	ET4041	
5675.....	71	5283.....	144
5801.....	67	ET4469	
5820.....	153	5283.....	109
5821.....	153	ET4471	
5834.....	70	5283.....	109
5835.....	69	ET5766	
584.....	58	5283.....	144
586.....	78	ET9304	
5865.....	76	5260.....	75
5867.....	73	5283.....	74
K820.....	152	ET9306	
K821.....	152	5260.....	75
E9306		5283.....	74
5023.....	77	EX9304	
5085.....	72	5525.....	55
5524.....	53	EX9306	
5525.....	53	5525.....	55
5545.....	50	M	
5555.....	51	M211.....	313
5556.....	51	M401.....	187-188
5600.....	65	M402.....	182
5600P.....	66	M403.....	183-186
5603.....	62-63	M409.....	181
5657.....	57	M5085.....	200
5672.....	68	M5260.....	203
5675.....	71	M5283.....	201-202
569.....	56	M5524.....	189
5801.....	67	M5525.....	189
5820.....	153	M553.....	190
5834.....	70	M5656.....	192
5835.....	69	M569.....	191
584.....	59	M5834.....	197
586.....	78	M584.....	193
5865.....	76	M5843.....	194
5867.....	73	M5865.....	204
K820.....	152	M5873.....	199
K821.....	152	T	
E9340		T5241.....	312
5672.....	83	T5283.....	310
E9341		T5285.....	311
5603.....	79	Z	
5672.....	83	Z847031.....	336
5675.....	85	ZFAD05.....	335
5820.....	154	ZFAG01.....	334
E9342		ZFAR02.....	335
5603.....	80	ZFAR03C.....	335
5672.....	83	ZFAR07.....	335
5675.....	85	ZFAR08.....	335
5801.....	82	ZFAR10D.....	337
5820.....	154	ZFAT.....	334
E9343		ZFCE.....	334
5603.....	81	ZFCM07IN.....	336
5672.....	83	ZFCM08IN.....	334
5675.....	85	ZFM07IN.....	331-332
5801.....	82	ZFM07RE1.....	333
5820.....	154	ZFM08IN.....	331
5834.....	84	ZFS07IN.....	336
E95.....	288-292		
EM.....	173-179		
ER.....	180		



TOOLING SYSTEMS catalogue is part of the Seco MACHINING NAVIGATOR collection.

Here you will find the most recent spindle tooling products and guides to successfully equip your machine tools.

The EPB tooling systems product range is divided into 7 product families: MONOBLOC – COMBIMASTER – GRAFLEX® – SECO-CAPTO™ – ADDITIONAL EQUIPMENT – SHRINKFIT DEVICES.

Each product family catalogue chapter contains:

- Guide pages, with dedicated technical information and main operating instructions.
- Product pages with product Part Numbers and detailed dimensions.

Monobloc

Solid holders with HSK 'hollow shank taper' (HSK-A, HSK-E) and SA 'steep angle' (DIN 69871, BT). 'Workpiece side' types to hold milling, turning, drilling, tapping and reaming tools.

Notice the Steadyline holders with shell mill, Combimaster, Shrinkfit machine sides, with built in damping feature, for long machinings at high productivity.

The Accu-Fit™ shell mill holders, with a hydraulic expandable spigot to minimize cutting tool run-out.

Axiaset shell mill holders adjustable in length for e.g. multi-spindle machines.

Shrinkfit holders, EPB 5672 collet chucks and hydraulic chucks form the HSM 'High Speed Machining' programme of products within the MONOBLOC ranges.



Combimaster

A modern milling solution used as an alternative to side lock holders and collet chucks.

The cylinder-flange interface with central thread provides slimmer and easy access tooling, by improving rigidity, precision and balance.

Combimaster holders (arbors, intermediates and adapters) are shown in this catalogue; Combimaster cutting heads are shown in the Milling catalogue.



Graflex®

The Graflex® Modular System has a leading reputation for 'flexibility' without 'weakness'.

Customised tooling dimensions closest to the required machining operation can rapidly be built together from standard arbors, intermediates and toolholders. Graflex® arbors and intermediates are also used to hold the whole range of boring heads, shown in the Holemaking catalogue.



Seco-Capto™

The Seco-Capto™ modular tooling range uses the PSC (Polygonal Shank Coupling) couplings, in accordance with the Norm ISO 26623.

More Seco-Capto™ tooling, clamping units and tools for turning are shown in the Turning catalogue.



Additional Equipment

This shows the items to be used in conjunction with the main holders (e.g. pull studs, collets, tap adapters, Shrinkfit - collet chuck - tapping extensions, plus e.g. Tool Boy assembly supports, HSK locking units).

Note: 'Accessories' and 'Spare parts' shown in the sub-tables of the Product pages in any catalogue chapter are items for handling or adapting the products shown on the page (e.g. spanners, stop end screws, sealing nuts).



Shrinkfit Devices

Here you can select dedicated tool 'shrinking' equipment to meet your requirements.

The Easyshrink® devices achieve fast and reliable 'shrink grip' and 'shrink release' operations of all tool shank types (carbide - heavy metal - steel - HSS), using induction heating.

Easyshrink® 20 is a modular device concept: select and build up your best suitable equipment.

Easyshrink® 15 is a compact device, an easy entry to the Shrinkfit technology.

Easyshrink® 20 Packs exist in 3 versions from 'basic' to 'high', but all include heating, cooling (air and/or water) and shrink depth setting features.





Monobloc and Graflex® toolholders (overview page 1/4)

	Shell mill holders, Accu-Fit™	Steadyline™ shell mill holders	Shell mill holders (including Axiaset*, Combi holders**...)	Milling cutter holders, flange mounting
Guide pages:	page(s) 26	page(s) 27-29	page(s) 30-31	page(s) 32
Product pages:				
HSK-A	page(s) 50	page(s) 51	page(s) 52-55	page(s) 56
HSK-E	-	-	-	-
DIN 69871	page(s) 86	page(s) 87	page(s) 88-90	page(s) 91
JIS (BT)	page(s) 115	page(s) 116	page(s) 117-119	page(s) 120
Graflex	-	-	page(s) 189-190	page(s) 191
	Disc mill holders	Side lock holders, Weldon	Side lock holders, Whistle Notch	Shrinkfit holders, DIN type
Guide pages:	page(s) 32	page(s) 33, 172	page(s) 33, 172	page(s) 34-35
Product pages:				
HSK-A	page(s) 57	page(s) 58-59	-	page(s) 60-63
HSK-E	-	-	-	page(s) 79-81
DIN 69871	page(s) 92	page(s) 93-95	-	page(s) 96-97
JIS (BT)	page(s) 121	page(s) 122-125	-	page(s) 126-129
Graflex	page(s) 192	page(s) 193	page(s) 194	page(s) 195

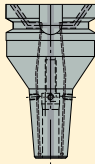

* Axiaset only available in HSK-A

** Combi shell mill holders only available in Graflex®

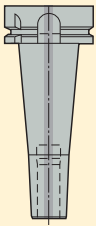
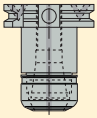
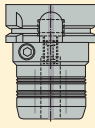
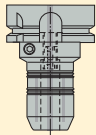
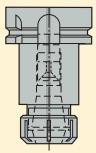
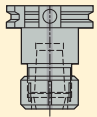
Monobloc and Graflex® toolholders (overview page 2/4)

	<p>Shrinkfit holders, reinforced</p> 	<p>Shrinkfit holders, reinforced and with tool pull-out protection</p> 	<p>Shrinkfit holders, Mould and Die type</p> 	<p>High precision collet chucks</p> 
Guide pages:	page(s) 34, 36	page(s) 34, 37	page(s) 34, 38	page(s) 39-40
Product pages:				
HSK-A	page(s) 64-65	page(s) 66	page(s) 67	page(s) 68
HSK-E	–	–	page(s) 82	page(s) 83
DIN 69871	page(s) 98-99	page(s) 100	page(s) 101	page(s) 102
JIS (BT)	page(s) 130-132	page(s) 133-134	page(s) 135	page(s) 136
Graflex	–	–	–	page(s) 196
	<p>Hydraulic chucks, strong</p> 	<p>Hydraulic chucks</p> 	<p>ER collet chucks</p> 	<p>OZ collet chucks</p> 
Guide pages:	page(s) 41-42	page(s) 43	page(s) 44	page(s) 45
Product pages:				
HSK-A	page(s) 69	page(s) 70	page(s) 71	–
HSK-E	–	page(s) 84	page(s) 85	–
DIN 69871	page(s) 103	page(s) 104	page(s) 105	page(s) 106
JIS (BT)	page(s) 137	page(s) 138	page(s) 139-140	page(s) 141
Graflex	–	page(s) 197	page(s) 198	page(s) 199

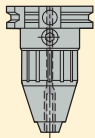
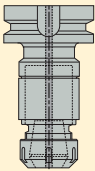
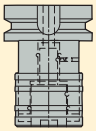
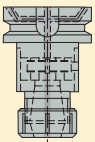

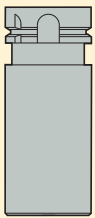
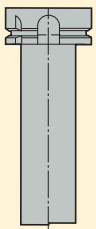
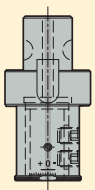

Monobloc and Graflex® toolholders (overview page 3/4)

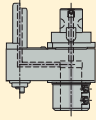
	Universal drill chucks	Tapping chucks for synchronized tapping, with micro-compensation	Quick change tapping chucks (with/ without compensation)	ER tapping chucks (without compensation)
				
Guide pages:	page(s) 45	page(s) 46	page(s) 47	page(s) 47
Product pages:				
HSK-A	page(s) 72	page(s) 73	page(s) 74-75	page(s) 76
HSK-E	-	-	-	-
DIN 69871	page(s) 107	page(s) 108	page(s) 109	page(s) 110
JIS (BT)	page(s) 142	page(s) 143	page(s) 144	page(s) 145
Graflex	page(s) 200	-	page(s) 201-203	page(s) 204
	Taper adapters (SA/ HSK)	Greenstock blanks	Test/ Control bars	Adjustable drill holders
				
Guide pages:	-	page(s) 48	page(s) 48	page(s) 47
Product pages:				
HSK-A	-	page(s) 77	page(s) 78	-
HSK-E	-	-	-	-
DIN 69871	page(s) 111-112	page(s) 113	page(s) 114	-
JIS (BT)	page(s) 146	page(s) 147	page(s) 148	-
Graflex	-	-	-	page(s) 205-206

Monobloc and Graflex® toolholders (overview page 4/4)

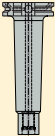
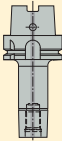
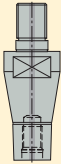

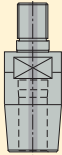
	Rotary coolant inducers
	
Guide pages:	page(s) 49, 172
Product pages:	
HSK-A	–
HSK-E	–
DIN 69871	–
JIS (BT)	–
Graflex	page(s) 207-210

Combimaster holders (overview page 1/1)



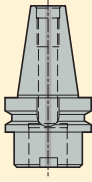
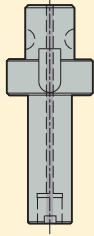
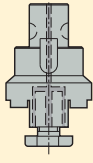

	Steadyline vibration damping Combimaster holders	Combimaster arbors	Combimaster intermediates, extensions and reducers	Cylindrical, Weldon and Morse Taper adapters for Combimaster
				
Guide pages:	page(s) 150-151	page(s) 149	page(s) 149	page(s) 149
Product pages:				
HSK-A	page(s) 152	page(s) 153	-	-
HSK-E	-	page(s) 154	-	-
DIN 69871	page(s) 155	page(s) 156	-	-
JIS (BT)	page(s) 157	page(s) 158	-	-
Cylindrical	-	-	-	page(s) 161
Weldon	-	-	-	page(s) 162
Morse taper	-	-	-	page(s) 163
Extensions	-	-	page(s) 159	-
Reducers	-	-	page(s) 160	-
Graflex	-	-	-	-
	Graflex® adapters for Combimaster	Combimaster Shrinkfit holders	Combimaster heads	
				
Guide pages:	page(s) 149	page(s) 149	See Machining Navigator Milling	
Product pages:		page(s) 165	See Machining Navigator Milling	
HSK-A	-			
HSK-E	-			
DIN 69871	-			
JIS (BT)	-			
Cylindrical	-			
Weldon	-			
Morse taper	-			
Extensions	-			
Reducers	-			
Graflex	page(s) 164			

Note: Combimaster holders and heads are shown in Machining Navigator Milling

Graflex® modular system (overview page 1/1)

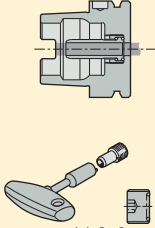
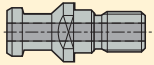
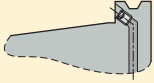
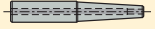
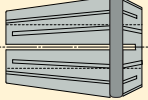
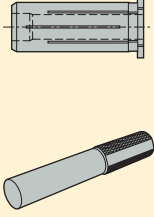
	Arbors (HSK-A, HSK-E, DIN 69871, DIN/CAT, JIS BT DIN 2080, Adjustable, Flange mounts)	Intermediates (Extensions, Reducers, Enlargers, Cyl. extensions)	Tool holders (for details, see Monobloc and Graflex® holders overview pages)	Accessories and spare parts for the Graflex® connection
				
Guide pages:	page(s) 170	page(s) 171-172	page(s) 172	page(s) 169
Product pages:	page(s) 173-181	page(s) 182-188	page(s) 189-210	page(s) 211-212

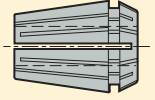
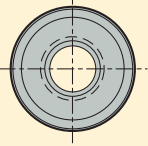
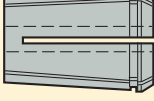

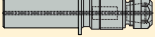

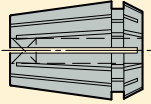
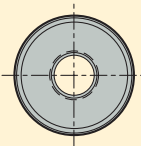
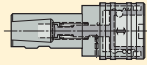
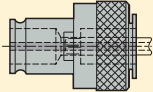
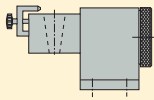
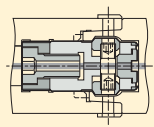
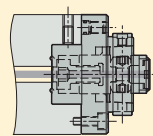

Additional equipment (overview page 1/2)

<p>Guide pages:</p> <p>Product pages:</p>	<p>HSK coolant tubes and sealing plugs (incl. tube fitting keys)</p>  <p>page(s) 278</p> <p>page(s) 287</p>	<p>Pull studs</p>  <p>page(s) 278</p> <p>page(s) 288-292</p>	<p>Sealing plugs for ADB tapers (spare parts)</p>  <p>page(s) 278</p> <p>page(s) 293</p>	<p>Shrinkfit holders with cylindrical shank</p>  <p>page(s) 279</p> <p>page(s) 294</p>
<p>Guide pages:</p> <p>Product pages:</p>	<p>ER HP collets</p>  <p>page(s) 280</p> <p>page(s) 297-300</p>	<p>Reduction sleeves, control gauges for hydraulic chucks</p>  <p>page(s) 279</p> <p>page(s) 295-296</p>	<p>ER collet chucks with cylindrical shank</p>  <p>page(s) 281</p> <p>page(s) 301</p>	<p>ER collets (standard and high precision types)</p>  <p>page(s) 281</p> <p>page(s) 302-303</p>
<p>Guide pages:</p> <p>Product pages:</p>	<p>ER sealing rings</p>  <p>page(s) 282</p> <p>page(s) 304</p>	<p>OZ collets</p>  <p>page(s) 282</p> <p>page(s) 305</p>	<p>Tapping chucks for synchronized tapping, with micro-compensation with combined Weldon and Whistle Notch shank</p>  <p>–</p> <p>page(s) 306</p>	<p>Tapping chucks for synchronized tapping, with micro-compensation, cylindrical</p>  <p>–</p> <p>page(s) 307</p>

Additional equipment (overview page 2/2)

	<p>ER tapping collets with square drive</p> 	<p>ER sealing rings for tapping chucks</p> 	<p>Quick change tapping chucks with combined Weldon and Whistle Notch shank (with compensation)</p> 	<p>Quick change tap adapters (with/ without torque limiter)</p> 
Guide pages:	page(s) 283	page(s) 283	page(s) 284	page(s) 284
Product pages:	page(s) 308	page(s) 309	page(s) 310	page(s) 311-312
	<p>Assembly supports, Tool Boy</p> 	<p>HSK locking units, TF</p> 	<p>HSK locking flange mounts, TF</p> 	
Guide pages:	page(s) 284	page(s) 285	page(s) 286	
Product pages:	page(s) 313	page(s) 314, 318	page(s) 315-317, 319-321	

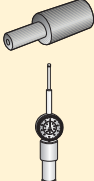
Shrinkfit devices (overview page 1/1)

<p>Guide pages:</p> <p>Product pages:</p>	<p>EasyShrink® 15 device</p>  <p>page(s) 322-324</p> <p>page(s) 331</p>	<p>Packs Easyshrink® 20</p>  <p>page(s) 322, 325-328</p> <p>page(s) 331-332</p>	<p>Refrigerated water cooling bells units</p>  <p>page(s) 328</p> <p>page(s) 333</p>
<p>Guide pages:</p> <p>Product pages:</p>	<p>Easyshrink® 15 and Easyshrink® 20 accessories and spare parts</p>  <p>page(s) 329</p> <p>page(s) 334-335</p>	<p>Shrinkfit height setting accessories</p>  <p>page(s) 330</p> <p>page(s) 336</p>	<p>Accessories for refrigerated water cooling bells units</p>  <p>page(s) 328</p> <p>page(s) 337</p>



Quality

The philosophy behind EPB products is based on total quality and is applied to each and every tool holder in the EPB range. Controls are carried out at all stages of the manufacturing process in accordance with ISO 9001.

- Material characteristics - 'classic' SA and HSK tool holders = case hardened steels, surface hardness 58 ± 2 HRC - Accu-Fit™, Shrinkfit and hydraulic holders = through hardened steels chosen for their superior performances, hardness 56 ± 2 HRC.
- Taper precision - SA tapers according to ISO 1947, tolerance class AT3 - HSK according to ISO 12164.
- Geometrical tolerances - direct run-out measured on the holder and/or run-out measured on a test gauge are in the catalogue. Run-out controls are made by simulating a spindle fitting.
- Overall finish - deburred, black oxide or special surface treatment and laser marking.
- Traceability - individual product marking relates to the quality information that is available.
- Fine balancing or pre-balancing information is listed in this catalogue for each holder. Residual unbalance controls are made by simulating a spindle fitting.



The balancing quality of each EPB holder is shown in its Product page balancing column:

1 = Fine-balanced, 2 = Pre-balanced.

1 = Fine balancing quality:

EPB holders suitable for HSM applications are balanced to $e = 3 \text{ g.mm/kg}$ maximum for holders with mass $M \geq 1 \text{ kg}$ or $U = 3 \text{ g.mm}$ maximum for holders $< 1 \text{ kg}$. Fine balanced HSK holders $\leq \text{HSK50}$ are balanced to $e = 1 \text{ g.mm/kg}$ maximum for holders with mass $M \geq 1 \text{ kg}$ or $U = 1 \text{ g.mm}$ maximum for holders $< 1 \text{ kg}$.

E.g.: Fine balancing a 2 kg holder BT 40 to $e = 3 \text{ g.mm/kg}$ max means that the permitted residual unbalance U can be 6 g.mm max.

Fine balancing a holder HSK-E40 weighing $0,7 \text{ kg}$ means that U can be 1 g.mm max (meaning $e = 1/0,7 = 1,43 \text{ g.mm/kg}$ max).

2 = Pre-balancing quality:

The majority of EPB holders are pre-balanced to $e = 30 \text{ g.mm/kg}$ maximum for holders with mass $M \geq 1 \text{ kg}$ or $U = 30 \text{ g.mm}$ maximum for holders $< 1 \text{ kg}$.

Most of the pre-balanced holders can be fine-balanced on request, please enquire.

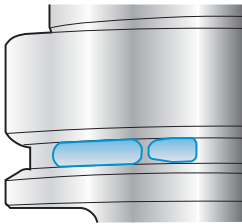

1 = Fine balancing, individual operation

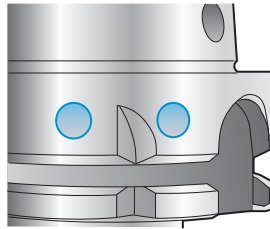

2 = Pre-balancing, standard operation

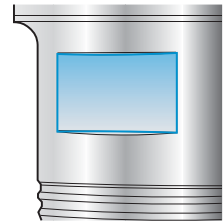

Balancing quality G:

Instead using e or U to define the balancing quality, it is possible to use G and n from the norm ISO 1940.

The relation between G and n in regard to e is shown on the chart taken from the norm ISO 1940.

See more information on next page.

ISO 1940

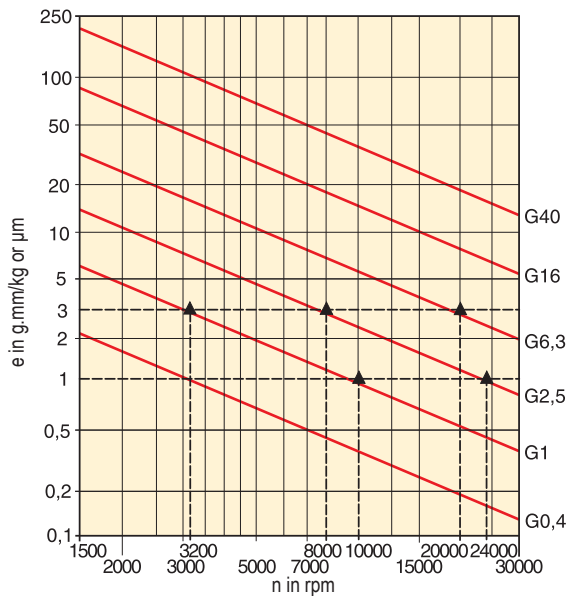

Residual unbalance U:

$$U = m \cdot r$$

U [g.mm] is the product of the unbalance mass m [g] and its distance to the rotational axis r [mm].

Value and direction of the residual unbalance U are measured using a balancing machine.

Residual unbalance U causes a centrifugal force F [N] to act on the rotating parts. This force will have, for example, a negative effect on the useful life of the spindle bearings.

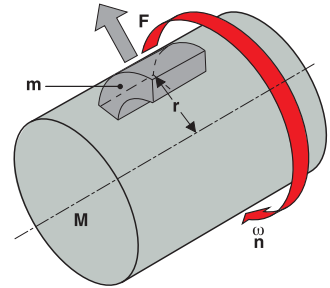

$$F = 10^{-6} \cdot U \cdot \omega^2$$

Balancing is the process which improves the distribution of the mass of a solid piece, in order to reduce U and its effect F to an acceptable level.

Balancing can be achieved by different methods: by adding weights (e.g. when balancing car wheels), removing material (EPB holders), or utilising settable compensations (e.g. balancing rings on EPB boring heads).

Specific unbalance e:

$$e = U/M \Leftrightarrow U = e \cdot M$$

e is also called unbalance eccentricity: e [g.mm]/[kg] or [µm] is the distance to which the centre of gravity is offset in regard to the holder's rotational axis.

Balancing reduces e, in other words, brings back the centre of gravity as near as possible to the axis of rotation.

Balancing quality G:

Norm ISO 1940 has established G as the unit of measurement for the balance quality of rotating parts.

G is the tangential speed of the centre of gravity in reference to the rotational axis.

$$G = \frac{e}{1000} \cdot \omega$$

$$G = \frac{U}{1000 \cdot M} \cdot \frac{2 \pi n}{60}$$

G = balance quality in mm/s

e = specific unbalance in g.mm/kg or µm

ω = speed in rad/s

U = residual unbalance, (U = e x M) in g.mm

M = mass of toolholder in kg

n = rpm

m = unbalance mass in g

r = distance between the unbalance mass and rotational axis in mm

Note: G is depending on n, M, U: It is not possible to define G without referring to the rotational speed. For toolholders it is preferable to use e and U to define their balancing quality:

– e or U can be generalised for all holders, while G has to be expressed against a specific n.

– e can easily be calculated from U, given by a balancing machine, divided by the mass M of the holder.

See on previous page the chart ISO 1940 showing the relation between G and n in regard to e.

Code key

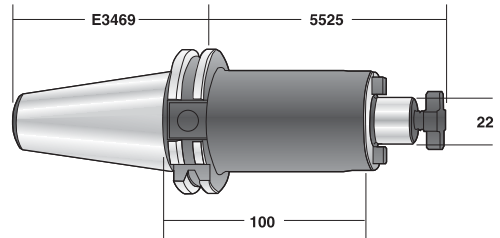
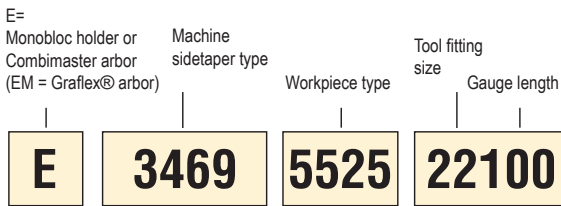

Workpiece side tool holding types

5545	Shell mill holders, Accu-Fit™
5555/5556	Steadyline™ shell mill holders
5525/5524	Shell mill holders with through coolant channels (5524 = small face)
552	Shell mill holders (small face)
X...5525	Shell mill holders, Axiaset™
553	Combi shell mill holders
569	Milling cutter holders, flange mounting
5656/5657	Disc mill holders
584	Side lock holders, Weldon
5842	Side lock holders, Weldon short
5843	Side lock holders, Whistle Notch
5603	Shrinkfit holders, DIN type
5600	Shrinkfit holders reinforced
5600 Safe-lock™	Shrinkfit holders reinforced with tool pull-out protection
5801	Shrinkfit holders, Mould and Die type
5672	High precision collet chucks
5835	Hydraulic chucks, strong
5834	Hydraulic chucks
5675	ER collet chucks
5450	ER collet chucks, with cylindrical shank
5873	OZ collet chucks
5085	Universal drill chucks
5867	Tapping chucks for synchronized tapping, with micro compensation
5283	Quick change tapping chucks with axial compensation
5260	Quick change tapping chucks for synchronised tapping
5865	ER tapping chucks for synchronised tapping
543	Taper adapters SA
5095	Taper adapters HSK
5023	Greenstock blanks
586	Test/Control bars
6100/6101	Adjustable drill holders
BSM	Rotary coolant inducers
K820/K821	Steadyline™ vibration damping Combimaster holders
5820/5821/5822	Combimaster arbors
401	Graflex® arbors
C	Seco-Capto™ arbors

Note: DIN 69882 defines the overall dimensions of some HSK-A holder sizes for types 5525, 553, 584, 5843, 5603, 5834 and 5675. EPB holders that conform to DIN 69882 are marked in the Product pages with an asterisk.

Delivery contents

Each item is delivered with all components included, also shown in the Product pages as 'Spare parts' (e.g. Weldon locking screw).

'Accessories' (e.g. ER sealing nut) and 'Additional equipment' (e.g. ER collet) are not included in the delivery content, please order separately.

Blind holes for data carriers

If not already available, blind holes for data carriers can be machined and data carriers fitted on request, please enquire.

HSK-A, norm dimensions

ISO 12164-1 Form A/ DIN 69893 Form A compatible

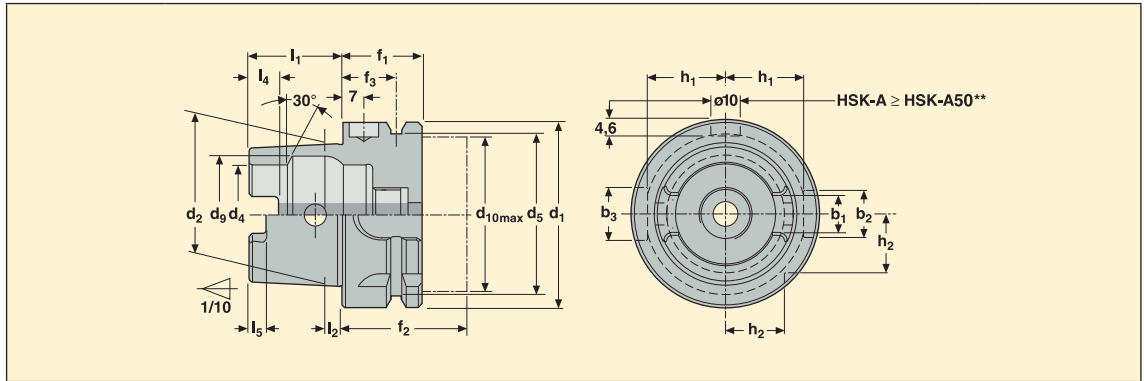

HSK	Machine side taper type	Dimensions in mm																	
		d_1	d_2	d_{10max}	d_4	d_5	d_9	f_1	f_2	f_3	l_1	l_2	l_4	l_5	b_1	b_2	b_3	h_1	h_2
HSK-A32	E9301...	32	24	26	17	26,5	21,0	20	35	16	16	3,2	5,0	3,0	7,05	7	9	13,0	9,5
HSK-A40	E9302...	40	30	34	21	34,8	25,5	20	35	16	20	4,0	6,0	3,5	8,05	9	11	17,0	12,0
HSK-A50	E9303...	50	38	42	26	43,0	32,0	26	42	18	25	5,0	7,5	4,5	10,54	12	14	21,0	15,5
HSK-A63	E9304...	63	48	53	34	55,0	40,0	26	42	18	32	6,3	10,0	6,0	12,54	16	18	26,5	20,0
HSK-A80	E9305...	80	60	67	42	70,0	50,0	26	42	18	40	8,0	12,0	8,0	16,04	18	20	34,0	25,0
HSK-A100	E9306...	100	75	88*	53	92,0	63,0	29	45	20	50	10,0	15,0	10,0	20,02	20	22	44,0	31,5

EPB's holders HSK-A have a radial hole through the taper for manual clamping, compatible with HSK-C.

Note: The following norm dimensions are applied to all the holders shown in the Product pages.

For HSK sealing plugs, coolant tubes and tube spanners, see page(s) 287.

* Note: HSK-A100 has d_{10max} 88 mm according to the latest norm ISO 12164.

** Data carrier blind hole location available as standard on all HSK-A50/63/80/100.

HSK-E, norm dimensions

DIN 69893 Form E with additional thread for coolant tube

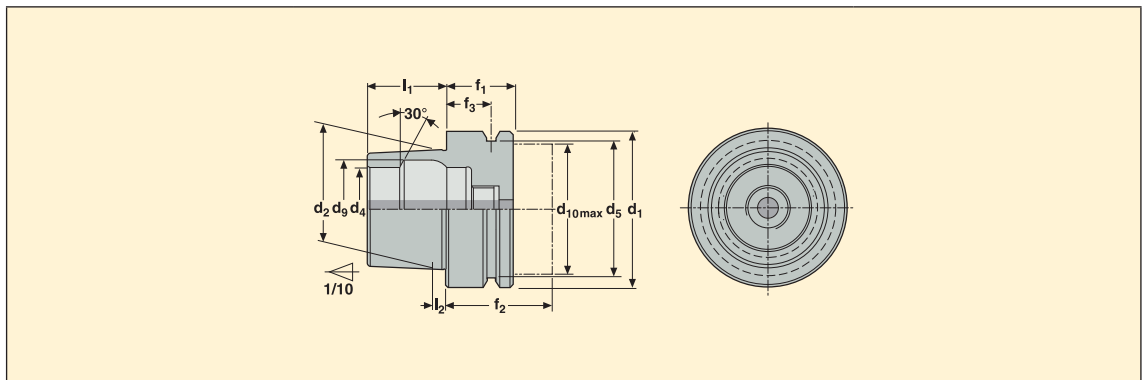

HSK	Machine side taper type	Dimensions in mm										
		d_1	d_2	d_4	d_5	d_9	d_{10max}	f_1	f_2	f_3	l_1	l_2
HSK-E32	E9341...	32	24	17	26,5	21,0	26	20	35	16	16	3,2
HSK-E40	E9342...	40	30	21	34,8	25,5	34	20	35	16	20	4,0
HSK-E50	E9343...	50	38	26	43,0	32,0	42	26	42	18	25	5,0

Note: EPB's newest HSK-E design has a thread to fit coolant tubes or sealing plugs from the HSK-A type (delivered by FIFO rule).

For HSK sealing plugs, coolant tubes and tube spanners, see page(s) 287.

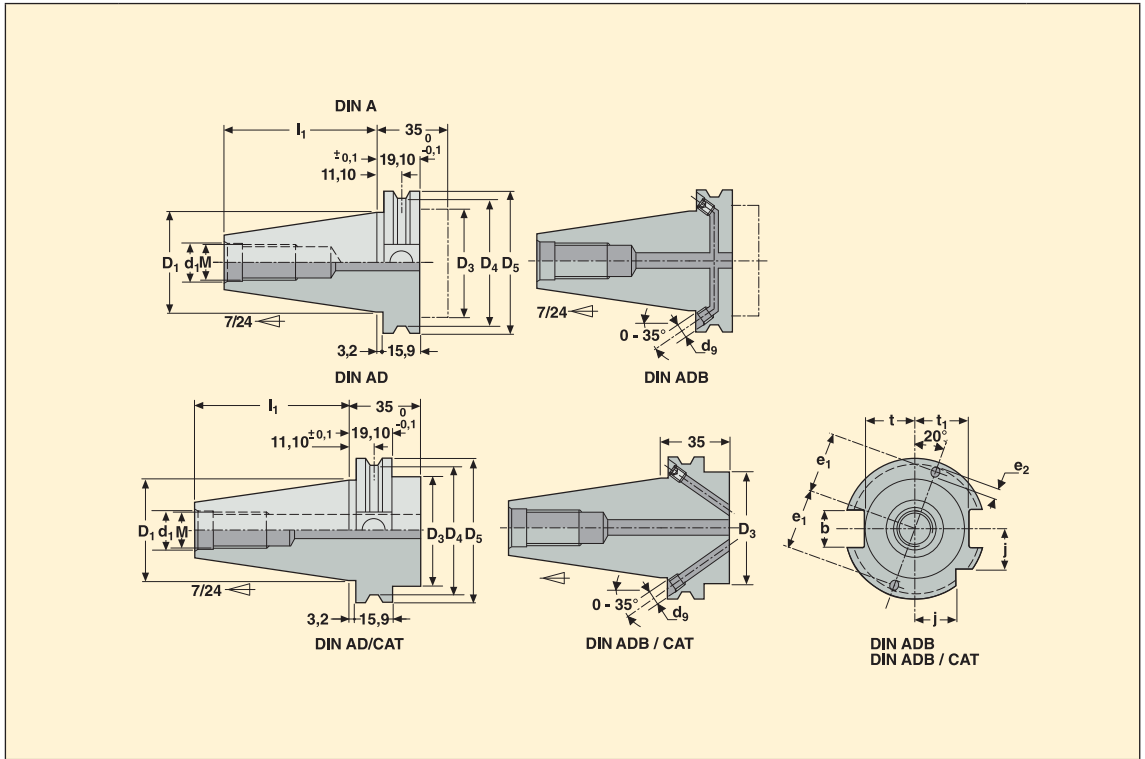

Taper	Through coolant Form	Machine side taper type	Dimensions in mm													
			D ₁	D ₃	D ₄	D ₅	$l_1^{+0,20}$	M	d_1^{H7}	d_9	e_1	e_2^{max}	t	t_1	b	j
DIN30	A/AD	E4464...	31,75	45 max	44,30	50,00	47,80	M12	13	-	-	-	16,4	19,0	16,1	15,0
DIN40	A/AD	E4469...	44,45	50 max	56,25	63,55	68,40	M16	17	-	-	-	22,8	25,0	16,1	18,5
DIN40 AD/CAT40	A/AD	E4466...	44,45	44,45	56,25	63,55	68,40	M16	17	-	-	-	22,8	25,0	16,1	18,5
DIN40 ADB	A/AD/B	E3469...	44,45	50 max	56,25	63,55	68,40	M16	17	4	27	5	22,8	25,0	16,1	18,5
DIN40 ADB/CAT 40	A/AD/B	E3476...	44,45	44,45	56,25	63,55	68,40	M16	17	4	27	5	22,8	25,0	16,1	18,5
DIN45	A/AD	E4470...	57,15	63 max	75,00	82,55	82,70	M20	21	-	-	-	29,1	31,3	19,3	24,0
DIN50	A/AD	E4471...	69,85	80 max	91,25	97,50	101,75	M24	25	-	-	-	35,5	37,7	25,7	30,0
DIN50 AD/CAT50	A/AD	E4468...	69,85	69,85	91,25	97,50	101,75	M24	25	-	-	-	35,5	37,7	25,7	30,0
DIN50 ADB	A/AD/B	E3471...	69,85	80 max	91,25	97,50	101,75	M24	25	6	42	7	35,5	37,7	25,7	30,0
DIN50 ADB/CAT50	A/AD/B	E3478...	69,85	69,85	91,25	97,50	101,75	M24	25	6	42	7	35,5	37,7	25,7	30,0

ADB type holders have two removable sealing plugs in the flange, in order to realise all through coolant types A, AD, or B. For spare plugs and pull studs, see page(s) 288-293.

DIN/ CAT indicate these holders of the DIN 69871 range feature the controlled diameter D3 of the CAT norm (CATERPILLAR ANSI B5 50 compatible only). Full ANSI-CAT conformity restricted by timing notch inclusion and metric pull-stud thread.

Note: Holders conforming to ANSI CAT (with imperial pull-stud threads) are shown in a separate catalogue, please enquire.

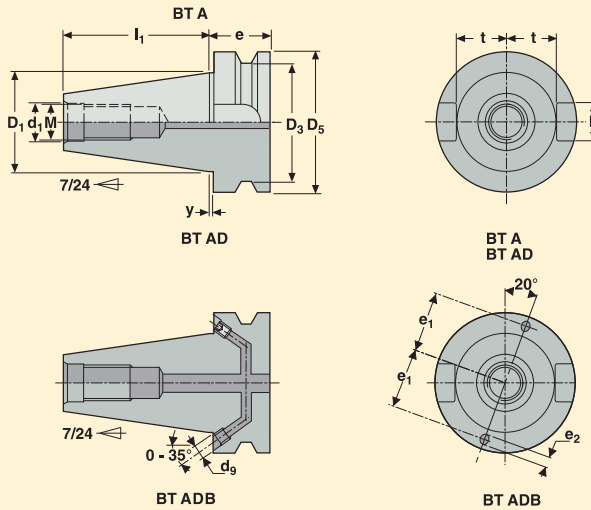

Taper	Through coolant Form	Machine side taper type	Dimensions in mm												
			D ₁	D ₃	D ₅ *	l ₁	M	d ₉	e ₁	e _{2max}	e	d ₁	t	b	y
BT30	A/AD	E4040...	31,75	38	46	48,4	M12	–	–	–	22	12,5	16,3	16,1	2
BT40	A/AD	E4041...	44,45	53	63	65,4	M16	–	–	–	27	17,0	22,5	16,1	2
BT40 ADB	A/AD/B	E3414...	44,45	53	63	65,4	M16	4	27	5	27	17,0	22,5	16,1	2
BT50	A/AD	E5766...	69,85	85	100	101,8	M24	–	–	–	38	25,0	35,4	25,7	3
BT50 ADB	A/AD/B	E3416...	69,85	85	100	101,8	M24	6	42	7	38	25,0	35,4	25,7	3

The B through coolant design of ADB holders is made according to DIN 69871 Form B.

ADB type holders have two removable sealing plugs in the flange, in order to realise all through coolant types A, AD or B. For spare plugs and pull studs, see page(s) 288-293.

* EPB BT holders with a front end diameter in excess of diameter D₅, are produced with a flange clearance length: BT30 = ∅ 45 mm x 3 mm; BT40 = ∅ 62 mm x 8 mm; BT50 = ∅ 98 mm x 12 mm. This is compatible with the BT JIS norm which permits free dimensions in front of the taper.

BT JIS-ADB for Taper -Face*, norm dimensions

JIS B 6339/ BT Form ADB/ ISO 7388-2

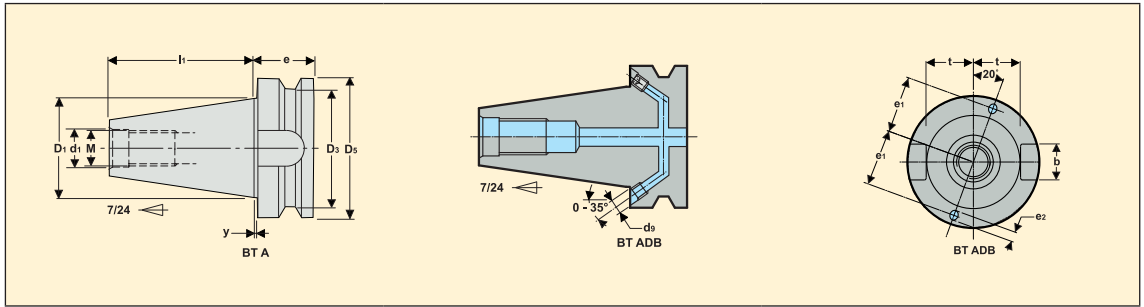

Taper	Through coolant Form	Machine side taper type	Dimensions in mm												
			D ₁	D ₃	D ₅ **	l ₁	M	d ₉	e ₁	e _{2max}	e	d ₁	t	b	y
BT40 ADB	A/AD/B	E3214...	44,45	53	63	65,4	M16	4	27	5	27	17	22,5	16,1	1,0
BT50 ADB	A/AD/B	E3216...	69,85	85	100	101,8	M24	6	42	7	38	25	35,4	25,7	1,5

The B through coolant design of ADB holders is made according to DIN 69871 Form B.

ADB type holders have two removable sealing plugs in the flange, in order to realise all through coolant types A, AD, or B. For spare plugs and pull studs, see page(s) 288-293.

** EPB BT holders with a front end diameter in excess of diameter D₅, are produced with the following clearance diameters: BT40 = ∅ 62 mm max x 8 mm; BT50 = ∅ 98 mm max x 12 mm. This is compatible with the BT JIS norm which permits free dimensions in front of the taper.

*Taper-Face (TF) holders BT are conform to the BT JIS Form ADB norm, except that they have a larger flange towards machine side, with tight tolerances: They achieve taper and face contacts on machine spindles with Taper-Face dimensions. They are also usable on standard spindles, however a gap remains between spindle and flange faces.

DIN 2080, norm dimensions

DIN 2080/ NF-E-60-024/ ISO 297

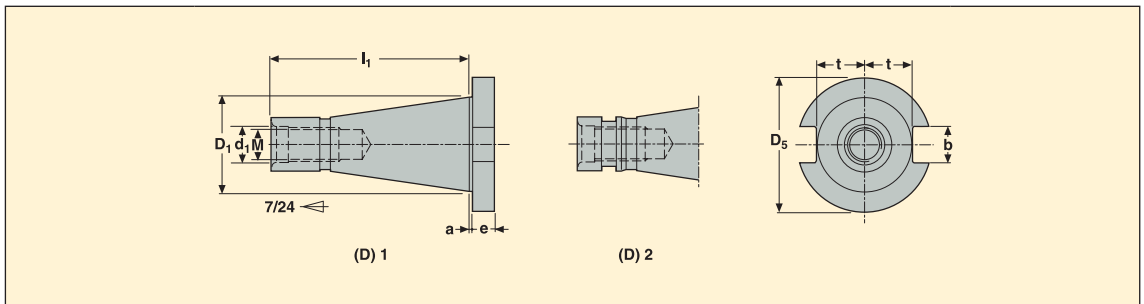

Taper	Machine side taper type	Design (D)	Dimensions in mm								
			D ₁	D ₅	l ₁	M	e	d ₁	t	b	a
DIN(2080) 40	E0040...	2	44,45	63,0	93,4	M16	10	17	22,5	16,1	1,6
DIN(2080) 50	E0050...	1	69,85	97,5	126,8	M24	12	26	35,3	25,7	3,2

DIN 2080 only available as Graflex® arbors.

Note: For pull studs to convert DIN 69871 and BT holders to DIN 2080 holders, see page(s) 292.

Shell mill holders, Accu-Fit™

Accu-Fit™, EPB 5545

Increase tool life and minimize run-out with EPB's new Accu-Fit™ – the hydraulic shell mill holder that provides the best connection between milling cutter and machine tool. Take precision manufacturing to an all-new level.

Fine balanced to 3 g.mm/kg, Accu-Fit™ is the best choice for high speed applications and difficult materials. As the mechanism is self-centering, balance of the assembled cutter and holder is maintained during operation.

Norm: Spigot and tenon drive features according to ISO 3937, but with larger bearing face OD than ISO (according to most recent cutters, for optimized rigidity).

Suitable milling cutters: For milling cutters with receiving bore tolerances and driving notches according to ISO 2780 (Bores H7 : Dia 22 or 27mm: 21µ; dia 32 or 40mm: 25µ), but with possible larger bearing faces OD than ISO, see OD of the holders.

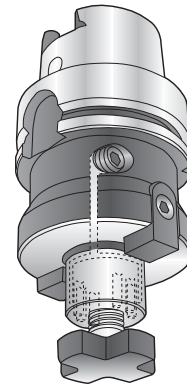

Accu-Fit™ holder's TruCentre™ design, details

Our patent-pending TruCentre™ design features an expandable hydraulic spigot to precisely hold the shell mill, eliminate play and minimize run out.

The clamping force between the cutter and the holder is further secured by the central bolt.

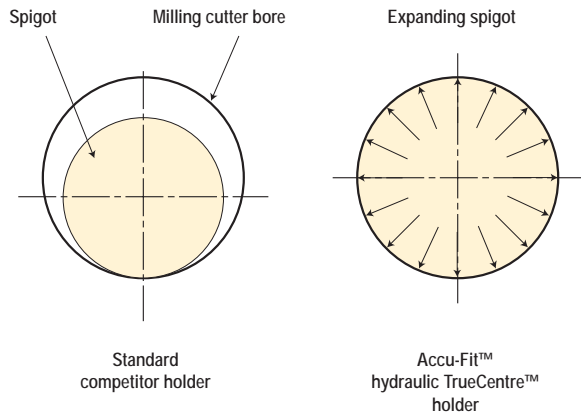
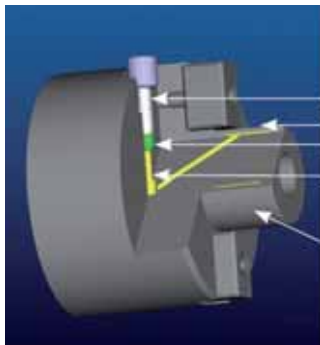

Other features

Large bearing face OD, same as EPB 5525.

Directional through coolant channels in the spigot, same as EPB 5525/5524.

Direct run-out of the spigot with fitted control ring in relation to the external taper is 5 µm maximum.

Accessories: When the cutter has no through coolant channels, it is possible to replace the standard cross head centre bolt by a cross head centre bolt with through coolant channels shown in Accessories. This will direct the coolant towards the cutter's front end.

Steadyline™ damping system, general information

The patented Steadyline™ damping system

A built-in vibration absorber dampens the vibrations as soon as they are transmitted by the cutting tool to the body of the holder. It prevents them from spreading along the bar, thus limiting the deflection of the milling assembly.

As a result, Steadyline™ vibration damping holders offer up to three times greater dynamic rigidity than equivalent solid holders.

The holders are ready to use, and offer the damping advantages regardless the type of rotating or static machining operation, the number of teeth in the cutter or the workpiece material.



Productivity booster

The Steadyline™ vibration damping system allow longer assemblies, much higher cutting conditions, with quieter operation and optimum stability. Key benefits are increased productivity, improved surface finish and longer tool and spindle life.

Problem solver

Steadyline™ holders are particularly recommended for:

- Milling and turning operations with long overhangs with predominantly radial forces.
- Machining of deep cavities in mould and die workpieces.
- Machining of complex monolithic (one piece) workpieces, particularly in the aerospace, automotive and power generation industries.

Steadyline™ tooling range

For milling, standard holders with Steadyline™ damping systems are available with Combimaster and Shell mill tool connections, see Product pages. For internal turning, threading and boring, the standard range of bars with the GL tool connection is shown in a separate Steadyline™ brochure, please inquire.

Steadyline™ damping is also widely applicable on custom made tooling and tools, please inquire.

Steadyline™ shell mill holders feature the Steadyline™ damping system.

See also Guide page 'Steadyline™ vibration damping system, general information'.



Productivity booster

The standard Steadyline™ shell mill holders enable machining over 5xD overhang with cutting speeds similar to short assemblies, hence increasing depth of cut up by up to 3 times compared to classic long holders : the chip removal rate can be drastically increased ! For longer assemblies, please enquire.

For recommended cutting conditions, see Instructions page.



Other features

- Types:** Steadyline™ shell mill holders type 5555 are cylindrical and 5556 are conical shaped for increased stiffness. Front end for tenon drive milling cutters is designed with large bearing face and through the spigot multi-channel coolant supply.
- Run-out:** Direct run-out of the spigot in relation to the external taper is 5 µm maximum.
- Balancing** Holders are pre-balanced (see Product pages 'Balancing' columns).

Shell mill holders, Steadyline™, main operating instructions

This page summarises the instructions delivered with the holders, as a pre-information. To ensure optimal use of the Steadyline™ shell mill holders, the detailed operating instructions delivered with the holder must be respected.

Note: The built-in damping system is ready to use, whatever the milling operation, the number of teeth in the cutter or the workpiece material.

Milling cutter fitting

Due to the high cutting conditions achievable, a reliable clamping of the milling cutter onto the Steadyline™ holder must be realised as below:

- Centre bolt with suitable length: For optimal use, the centre bolt has to stand out from the milling cutter back face (E) (see table).
- Centre bolt tightening torque: Apply the recommended centre bolt tightening torque (see table).

d ₁ (mm)	M (mm)	E min (mm)	E max (mm)	Tightening torque (Nm)
16	8	3	4	30
22	10	6	8	40
27	12	8	10	60
32	16	12	16	80
40	20	17	22	108

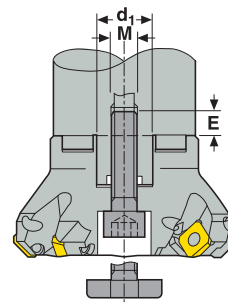

Recommended cutting conditions and maximum temperature

Make sure to never exceed the maximum RPM of the holder (indicated on the holder and listed in the table).

- Too high cutting conditions could cause vibrations of the milling assembly, this would prevent the damper operating properly and would damage the tool, the tool holder, the machine as well as the workpiece: set the cutting conditions in order to stay vibration free.

Optimal cutting conditions, selection procedure:

1. Cutting speed v_c and feed f : select the average values recommended for the cutter and inserts.
 2. The width of cut a_e and the depth of cut a_p maximum are the parameters to fine tune. It is possible to increase them inside cutter and inserts recommendations, while staying vibration free.
- BEWARE: contrary to the use of classic long holders, the machining cannot be stabilised through additional radial force (e.g. by raising the feed).

Make sure the Steadyline™ holder body never exceeds a maximum temperature when in use of 80° C.

d ₁ (mm)	Max. RPM	Operating temperature
16	8 000	80° C
22	8 000	
27	6 000	
32	4 000	
40	3 000	

Shell mill holders, Axiaset™

Multi-spindle productivity booster

Axiaset™ shell mill holders are designed to easily set two or more milling assemblies (shell mill holder + milling cutter) at the same length in order to obtain identical operations from the spindles of a multi-spindle machining centre or multi-spindle heads.

Axiaset™ offers a unique, economical, easy and efficient way for multispindle users to simultaneously run all the spindles also for accurate face milling applications, maximising productivity.



Axiaset™ shell mill holders: EPB X...5525

Based on a two part assembly :

- Front part with shell mill holder being identical to type 5525 (large bearing face, coolant supply multi-channels through the spigot) equipped with a length setting ring.
- Back part with the spindle taper.

When rotating the setting ring, the front part is pushed out from (or pulled into) the back part: translation only, no rotation.

Assembly is locked by two ball nose screws and a driving key.

Length adjustment capacity 3 mm ($\pm 1,5$ mm from average length).

Direct run-out of the spigot in relation to the external taper is 20 μ m maximum.

Adjustment through a graduated ring (pitch 0,02 mm), ball bearing guided.

Accessories: When the cutter has no through coolant channels, it is possible to replace the standard cross head centre bolt by a cross head centre bolt with through coolant channels shown in Accessories.

Operating instructions

Assembling a shell mill onto an Axiaset™ holder:

Place the milling cutter on the Axiaset™ holder, and tighten bolt (1).

Setting the programming length (A length):

1. Unlock the clamping screws (2) and (3) by two turns only.
 2. Using the setting ring (4), set the assembly at the required A length using a presetter or ring's graduation (1 increment = 0.02 mm in length).
- Tip: for precise A length setting, it is recommended to first decrease the A length by approx. 1/2 ring rotation, then increase it to the required A length.
3. Slightly tighten both clamping screws (2) and (3) (10 Nm maxi).
 4. Fully tighten both clamping screws (2) and (3) (25 Nm).

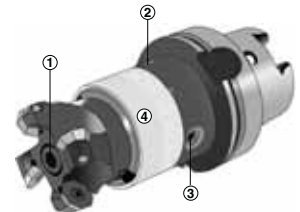

Setting two Axiaset™ assemblies (I) and (II) at the same height:

1. Set the assembly (I) (Axiaset™ holder + shell mill) to the required A length (see paragraph above).
2. Locking screws (2) and (3) being tightened, use a presetter to precisely measure the highest point of assembly's (I) cutting edges.
3. Determine the highest cutting edge of assembly (II).
4. Using this highest cutting edge as a reference, set duplicate assembly (II) at the same A length as assembly (I).

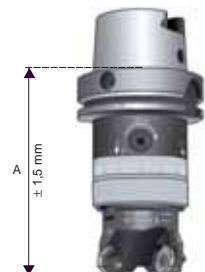

Maintenance

Setting system is lubricated for life.

During stocking, protect the Axiaset™ holders from corrosion.

Shell mill holders

Types:	EPB 5525, 5524 and 552 – Holders for tenon drive milling cutters. EPB 5525 and 5524 are with directional coolant channels through the spigot.
Norm:	EPB 5525: Spigot and tenon drive features according to ISO 3937, but with larger bearing face OD than ISO (according to most recent cutters, for optimized rigidity). EPB 5524 and 552, ISO 3937: small bearing face OD suitable for e.g. disc mill cutters Type B. EPB 5525 with $\varnothing 40$ have 4 threaded holes according to DIN 6357 in addition to the central locking bolt.
Run-out:	Direct run-out of the spigot in relation to the external taper is 5 μm maximum.
Balancing:	See Product pages.
Accessories:	When the cutter has no through coolant channels, it is possible to replace the standard cross head centre bolt by a cross head centre bolt with through coolant channels shown in Accessories. This will direct the coolant towards the cutter's front end.

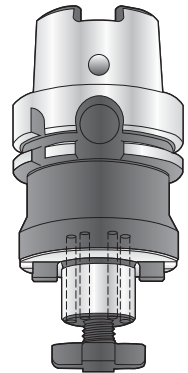

Combi shell mill holders

Types:	EPB 553 – For tenon drive cutters or key drive cutters by removing the driving ring.
Norm:	DIN 6358.
Run-out:	Direct run-out of the spigot in relation to the external taper is 5 μm maximum.
Balancing:	Not suitable for balancing due to the removable driving ring.

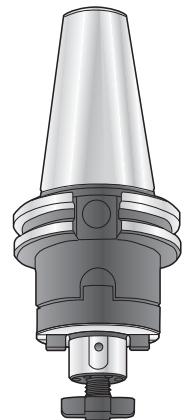

Milling cutter holders, flange mounting

- Types:** EPB 569 – For large diameter face mill cutters. Offering a large bearing face and secure locking using 4 screws according to DIN 2079. High torque transmission thanks to large driving keys.
- Norm:** DIN 6357/DIN 2079.
- Run-out:** Direct run-out of the spigot in relation to the external taper is 5 μm maximum.
- Balancing:** See Product pages.

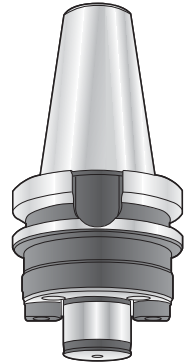

Disc mill holders

- Types:** EPB M5656, 5657 – The disc mill is held by an adjustable sliding shaft arbor equipped with a driving key. The arbor and disc mill are locked using a pulling screw. Slim front end clamping flange for optimised accessibility.
- Norm:** Suitable for e.g. Seco disc mill cutters Type A.
- Balancing:** See Product pages.



Side lock holders, Weldon

Types:	EPB 584 – The tool position is fixed as a result of the tool shank flat(s) and cannot be adjusted. The locking method offers high torque transmission. Bore sizes \varnothing 16, 20, 25, 32 and 40 mm have the front face ground (Seco Weldon shanks and flanges compatible).	
Norm:	DIN 1835-2 Form B/ISO 5414-1.	
Tool shanks:	Weldon DIN 1835-1 Form B/ DIN 6535 Form HB.	
Run-out:	Direct run-out of the bore to the external taper is 3 μ m. Reduced bore tolerances on \varnothing 6 to 18 mm is +1 to +5 μ m and \varnothing 20 and > is +1 to +7 μ m.	
Balancing:	See Product pages.	

Side lock holders, Weldon short

Types:	EPB 5842 – Short, giving maximum rigidity. Bore sizes \varnothing 16, 20, 25 and 32 mm have the front face ground (Seco Weldon shanks and flanges compatible).	
Norm:	Compatible to DIN 1835-1 Form B/ISO 5414-1 but not conformed.	
Tool shanks:	Weldon DIN 1835-1 Form B/ DIN 6535 Form HB.	
Run-out:	Direct run-out of the bore to the external taper is 5 μ m. Reduced bore tolerances on \varnothing 6 to 18 mm are +1 to +5 μ m and on \varnothing 20 and > are +1 to +7 μ m.	
Balancing:	See Product pages (1 = Fine balanced ; 2 = Pre-balanced).	

Side lock holders, Whistle Notch

Types:	EPB 5843 – Similar to Weldon, but with screw(s) angled 2° to lock the tool against an adjustable stop end screw. \varnothing 16, 20, 25 and 32 mm have the front face ground. A securing screw is provided for the stop end screw.	
Norm:	DIN 1835-2 Form E.	
Tool shanks:	Whistle Notch DIN 1835-1 Form E/ DIN 6535 Form HE.	
Run-out:	Direct run-out of the bore to the external taper is 3 μ m. Reduced bore tolerances on \varnothing 6 to 18 mm is +1 to +5 μ m and \varnothing 20 and > is +1 to +7 μ m.	
Balancing:	See Product pages (balancing with median clamping position of the screws).	

Shrinkfit holders, general information

A Shrinkfit tool holder works in conjunction with a specialised heater e.g. EasyShrink®. The bore in which the tool locates is slightly undersized compared to the tool shank. Heating the holder opens up this bore, allowing the tool to be inserted. As the holder cools, the bore shrinks around the tool to create a concentric and rigid clamping. Bore size \varnothing 3 mm to 32 mm.

Thermal expansion:

Approx. $11 \mu\text{m}/\text{m}/^\circ$ for steel and HSS

Approx. $6 \mu\text{m}/\text{m}/^\circ$ for carbide and heavy metal

e.g.: \varnothing 20, heating from 20°C to 270°C , increase of 250°C :

Steel: $0,020 \times 11 \times 250 = + 55 \mu\text{m}$

Carbide: $0,020 \times 6 \times 250 = + 30 \mu\text{m}$

Shrinkfit holders, all available front end types

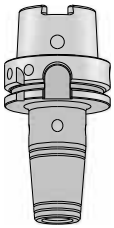

EPB 5603

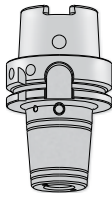

EPB 5600

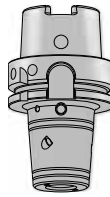

EPB 5600P

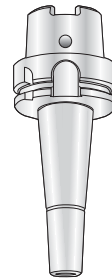

EPB 5801



EPB 5801

Suitable tool shank types and tolerances for Shrinkfit holders

Cylindrical DIN 1835-1 Form A/ DIN 6535 Form HA.

Note: Type 5600P requires the Safe-Lock™ shank execution (grooves).

Tool shank tolerance required

\varnothing 3 to 5 mm maximum h5, tool shank must be carbide or heavy metal (e.g. Densimet). \varnothing 6 to 32 mm maximum h6, tool shank can be steel, HSS, carbide or heavy metal. Using h5 for \varnothing 6 to 32 mm provides a safer minimum clamping torque. Make sure the minimum shrinking depth l_3 shown in the product pages for each holder is respected when fitting the tool shank into the holder.

Run-out

Maximum run-out when measured at a gauge projection of $3 \times d$ (d = bore dia.) in relation to the external taper or shank is $3 \mu\text{m}$.

Direct run-out of the holder bore in relation to the taper or the shank is $3 \mu\text{m}$ maximum.

Balancing

Shrinkfit holders are fine balanced as standard ; except Shrinkfit extensions, being pre-balanced.

Heat resistance

EPB Shrinkfit holders are made from heat resistant steel guaranteeing structure, geometry and dimensional stability after many Shrinkfit heating cycles. The maximum acceptable temperature is 400°C .

Stop end screw setting adapters with hexagonal back-end are available as Accessories, see Shrinkfit devices pages.

Set the stop end screw position taking into account the actual tool to be shrink-gripped. For application details, see the information in the Shrinkfit devices Guide pages.

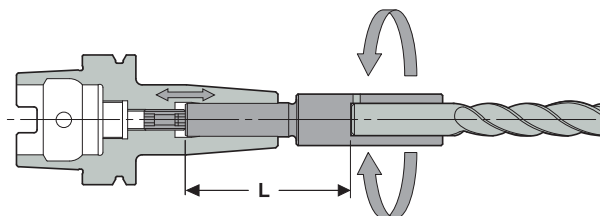

Stop end screw and setting adapter for holders type 5603

DIN type Shrinkfit holders, EPB 5603

See also Guide page ‘Shrinkfit holders, general information’.

EPB 5603 has a 4,5° nose angle, an internal thread for a stop end screw (stop end screw delivered with the holder) and 4 balancing threaded holes, according to norm DIN 69882-8.

The stop end screw has hexagonal back and front ends and a coolant through channel with front groove. Note: When using the stop rods from Easyshrink® 20 Shrinkfit devices for tool length setting, there is no need for a stop end screw.

Norm DIN 69882-8 also defines the overall dimensions of some HSK-A Shrinkfit holder type 5603 sizes (marked with an asterisk in the Product pages): for the other type 5603 holders, this norm only applies to the front end shape, the thread for a stop end screw and a stop end screw delivered with the holder, and the 4 balancing threaded holes.

Holders type 5603 with diameters 3 to 5 mm as well as extra short holders have neither thread for stop screw (no stop screw delivered) nor balancing threaded holes, due to lack of space (see information in Product pages). Holders type 5603 in Combimaster and in Seco-Capto™ have no balancing threaded holes.



Transmittable torque to the tool shank (Nm) and Max RPM, Shrinkfit holders EPB 5603

Clamp Ø (mm)	Minimum static transmittable torque (Nm)	Shrinkfit clamping system Max RPM*
6	18	45 000
8	35	45 000
10	65	40 000
12	110	40 000
14	150	38 000
16	200	38 000
18	250	35 000
20	320	35 000
25	500	32 000
32	550	30 000

* The maximum RPM for holders equipped with this clamping system is often restricted by the holder’s machine side taper type and size.

A kit of balancing screws for Shrinkfit holders EPB 5603 and EPB 5600 is available as Accessories (Part N° 90ZQ01)

The kit contains screws of different masses, to be fitted into holder’s balancing threaded holes of Shrinkfit holders type 5603.

Balancing screws allow fine tune balancing of Shrinkfit holder and tool assemblies when using a suitable balancing machine. The appropriate balancing screws are meant to be screwed until stop in the threaded holes, with a torque of 1 Nm.

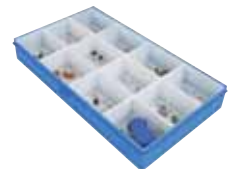

Shrinkfit holders, reinforced, EPB 5600

See also Guide page ‘Shrinkfit holders, general information’.

Reinforced design:

The Shrinkfit front part OD dimensions are one size wider compared to type 5603. The body part from flange to Shrinkfit front is conical reinforced.

Periphery through coolant channels, with removable plugging screws:

When using tools without through coolant, remove the plugging screws to direct coolant towards the cutting edges.

The reinforced design achieves up to 40% more tool transmittable torque and higher rigidity, for increased productivity and quality performances. The coolant supply directed towards the cutting edges increases tool life.



Other features, Shrinkfit holders EPB 5600

Shrinkfit front with 4,5° nose angle (similar to DIN EPB 5603 holders but one size wider).

Internal thread for a stop end screw. A stop end screw is delivered with the holder (similar to DIN type 5603 holders). The stop end screw features a central hole and a concave front face for through coolant with tools with through coolant.

4 balancing threaded holes for balancing screws (similar to DIN type 5603 holders). A kit of balancing screws is available as accessories, see guide page of EPB 5603 Shrinkfit holders.

Due to their dimensions (lack of space), some holders type 5600 don't have threads for stop screws (no stop screw delivered) or no balancing threaded holes (see information in Product pages).

The coolant channels design and numbers achieve high coolant flow: 2 channels up to \varnothing 20 mm, 3 channels for \varnothing 25 and 32 mm.

Coolant channel plugs are designed to be fitted without using additional equipment. Plug removal is easy and reliable.

The reinforced front ends of EPB 5600 Shrinkfit holders require a specific heating program on the Easyshrink® 15 and 20 Shrinkfit devices.

Transmittable torque to the tool shank (Nm) and Max RPM, Shrinkfit holders, reinforced, EPB 5600

Clamp \varnothing (mm)	Minimum static transmittable torque (Nm)	Shrinkfit clamping system Max RPM*
6	25	45 000
8	48	45 000
10	90	40 000
12	150	40 000
16	280	38 000
20	420	35 000
25	620	30 000
32	750	25 000

* The maximum RPM for holders equipped with this clamping system is often restricted by the holder's machine side taper type and size.

Shrinkfit holders, EPB 5600 Safe-Lock™

See also Guide page 'Shrinkfit holders, general information'.

The EPB 5600 Safe-Lock™ Shrinkfit holders combine a pull-out protection system for round shanked cutting tools with the highly accurate Shrinkfit clamping.

Safe-Lock™ tool pull-out protection system:

Drive pins are fitted into the Shrinkfit toolholder bores. In combination with spiral-shaped grooves of the cylindrical cutting tool shank, the pins prevent the tool from being pulled-out of the chuck during extreme machining. Most SECO Jabro-HPM solid end mills now can be ordered with Safe-Lock™ shank execution (grooves) on demand.

Safe-Lock™ is the solution against tool pull-out effects, it:

- secures the tool clamping,
- avoids tool ejection, workpiece scrapping, and damage on machine spindle,
- ensures optimum process reliability and longer tool life
- increases productivity as the milling cutter can be used with its maximum cutting data.



Using the EPB 5600 Shrinkfit design

Safe-Lock™ Shrinkfit holders use the EPB 5600 reinforced Shrinkfit design : see EPB 5600 Guide pages.

Differences EPB 5600 Safe-Lock™ vs EPB 5600:

Tools require the Safe-Lock™ shank execution.

Stop end screw fitted in the holder vs in delivery content.

Due to their dimensions (lack of space), some EPB 5600 Safe-Lock™ holders don't have threads for stop screw and therefore no stop screw, and/or no balancing threaded holes (see information in Product pages).

Max RPM, Shrinkfit holders EPB 5600 Safe-Lock™

Clamp Ø (mm)	Shrinkfit clamping system Max RPM*
12	45 000
16	38 000
20	35 000
25	30 000
32	25 000

* The maximum RPM for holders equipped with this clamping system is often restricted by the holder's machine side taper type and size.



Suitable tool shanks, to be:

Cylindrical DIN 1835-1 Form A/ DIN 6535 Form HA with Safe-Lock™ shank execution.

SAFE-LOCK™
by HAIMER.

Mould and Die type Shrinkfit holders, EPB 5801

See also Guide page 'Shrinkfit holders, general information'.

Mould and Die Shrinkfit holders, EPB 5801 available in Monobloc and as cylindrical extension (see Additional equipment).

Long and slim 5°/3° nose angle design, with coated external surfaces. Designed to be particularly suitable for Mould & Die application.

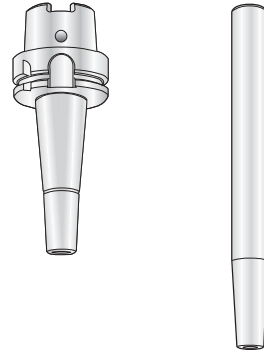

High precision collet chucks, EPB 5672

Type:

EPB 5672 – High performance collet chuck system combining high run-out precision, high transmittable torque and HSM suitability.

Run-out:

Maximum run-out, in relation to holder's back end taper is 3 µm when measured with an ER HP collet at a gauge projection of 3xd (up to a maximum of 50mm).

Suitable collets ER HP type 5672:

The high precision collet chucks EPB 5672 require a specific range of collets ER HP type 5672, see Additional Equipment.

The collet designation 'ER HP' indicates that the collet type 5672 is based on the external design of ISO 15488-B (ER), but equipped with a distinguishing plastic ring in the locking groove to avoid confusing it with a classic ER collet that would not provide the run-out mentioned above.

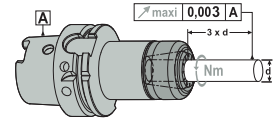

Transmittable static torque to the tool shank (Nm)

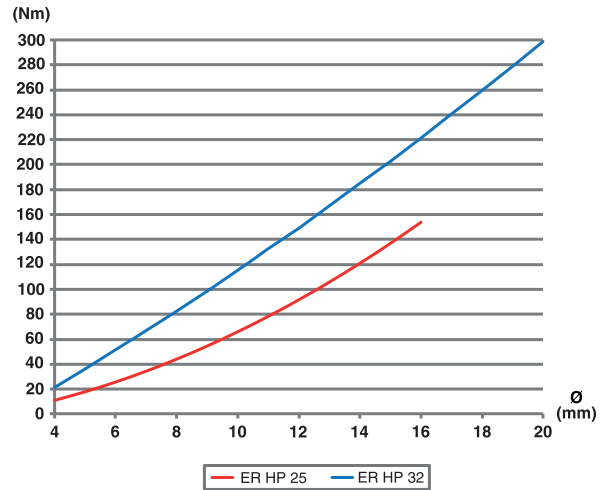
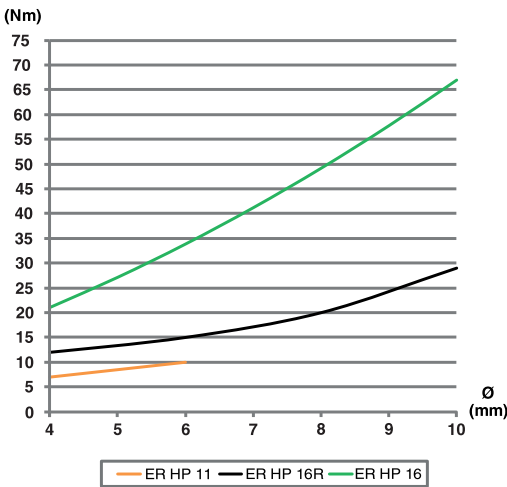

Transmittable static torques when collet nuts are tightened at Max. torque.

Balancing:

Fine balanced is standard.

Norm:

No norm.

Tool shanks:

Cylindrical DIN 1835-1 Form A/ DIN 6535 Form HA.

Tool shank diameter to be similar to collet's bore (no clamping capacity) and tolerance h10 maxi.

Through coolant supply:

1/ When using 'not sealed' collets and no stop end screw, the coolant flows through the collet's grooves, along the tool shank.

2/ To direct the coolant through the tool shank, two solutions are available:

- sealing obtained by using a concave tapered stop end screw available as Accessories (for tool shanks without groove)
- sealing obtained by using sealed collets (available as Additional equipment).

Stop end screw:

High precision collet chucks are delivered as standard without stop end screws. Stop end screws are not recommended for high spindle speeds, e.g. over 10 000 rpm. When using a stop end screw, its tapered contact onto the tool shank can increase the tool run-out defect. Stop end screws have to be ordered separately, see Accessories.

High precision collet chucks, EPB 5672 (cont.)

Roller spanners are required to tighten and release the plain cylindrical collet nuts of EPB 5672 chucks. Standard spanners and dynamometric spanners are available as Accessories, to be ordered separately.

The use of a dynamometric spanner is recommended for collet nut tightening: reliable application of the recommended clamping torque guarantees high transmittable torque to the tool and prevents nut or collet deformation.

For nut releasing, it is recommended to use a standard spanner: Dynamometric spanner's handle mechanism could be damaged by possible required higher untightening torque compared to the set torque for tightening.



Dynamometric roller spanner, Tip/Handle



Standard roller spanner

Recommended tightening torque for the collet nut

Collet chuck size	Capacity d mm	Recommended tightening torque*
HP 11	1-7	10 Nm
HP 16R	1	10 Nm
	1,5-3,5	15-20 Nm
	4-10	25-30 Nm
HP 16	1	10 Nm
	1,5-3,5	25-30 Nm
	4-10	50-55 Nm
HP 25	2-3	25-30 Nm
	3,5-6,5	35-40 Nm
	7-10	55-60 Nm
	10,5-16	80-90 Nm
HP 32	2-3	30-35 Nm
	3,5-6,5	55-60 Nm
	7-15,5	110-120 Nm
	16-20	130-140 Nm

* Suitable roller spanner, standard and dynamometric types are available as Accessories, see Product pages.

High precision type clamping system Max RPM

Collet chuck size	Capacity d mm	HP type clamping system Max RPM*
HP 11	1-7	50 000
HP 16R	1-10	50 000
HP 16	1-10	60 000
HP 25	2-16	42 000
HP 32	2-20	30 000

* The maximum RPM for holders equipped with this clamping system is often restricted by the holder's back-end taper type and size.

Operating instructions: To ensure optimal use of the high precision collet chucks, the detailed operating instructions delivered with the holder must be respected.

Hydraulic chucks, strong, EPB 5835

Hydraulic chucks, strong type, for High Performance Cutting are specially designed for rough milling applications. This holder allows higher cutting data thanks to the high transmittable torque, a great rigidity due to short design and a hydraulic system that minimizes vibration during machining.

An internal piston pressurises hydraulic fluid into a chamber surrounding the holder bore. The high pressure is uniformly applied to grip 360° around the tool shank. Cutting tools are held with excellent precision. The bore has a helical groove where dirt, oil or grease can collect when it has inadvertently been left on the tool shank. The pressurising screw must be tightened until stop using the dedicated key available as Accessories (see Product pages).

PLEASE NOTE: Never lock the chuck without a tool in place. This would damage the chamber and make the chuck unusable.



Tool shanks

Cylindrical DIN 1835-1 Form A/ DIN 6535 Form HA, Ø 12, 20, 32 mm and Weldon DIN 1835-1 Form B/ DIN 6535 Form HB, Ø 12, 20 mm. Additional tool shank diameters can be clamped using reduction sleeves (see next page).

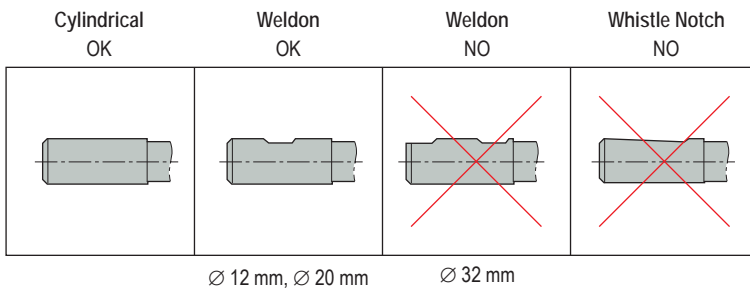

Shank tolerance
h6 maximum.

Run-out

Maximum run-out when measured at a gauge projection of 3 x d in relation to the external taper is 4 µm.

Balancing

Fine-balanced as standard.



Clamp Ø (mm)	Minimum static transmittable torque (Nm)	Operating temperature	Max. coolant pressure	Hydraulic system Max RPM
12	200	10-50°C	70 bars	30000
20	450			25000
32	1000			18000

* The maximum RPM for holders equipped with this clamping system is often restricted by the holder's machine side taper type and size. To reach maximum transmittable torque, the tool shank and bore must be clean and dry. Suitable cleaning brushes, see Additional equipment chapter in MN 2012 Tooling.

Hydraulic chucks, strong, EPB 5835 and EPB 5834

Control gauges, see Additional equipment

To check that the pressure of hydraulic chucks remains sufficient, it is recommended to regularly test the chucks with suitable gauges, shown in MN 2012 Tooling, chapter Additional equipment.

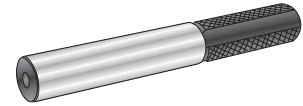

Hydraulic chuck control instructions summary, using a control gauge:

Insert the control gauge into the chuck.

Tighten the clamping screw until you cannot turn the control gauge.

Then it should be possible to complete a minimum of three full turns of the pressurising screw, before completely tightening.

This will confirm that the clamping capability is adequate.

Note: Detailed control instructions are part of the operating instruction sheet delivered with the hydraulic chucks.

Reduction sleeves for hydraulic chucks, see Additional equipment

The reduction sleeves for hydraulic chucks act as split collets allowing more shank types and sizes to be gripped (see below). The run-out with the sleeve is maximum 5 µm at 3 x d.

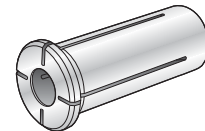
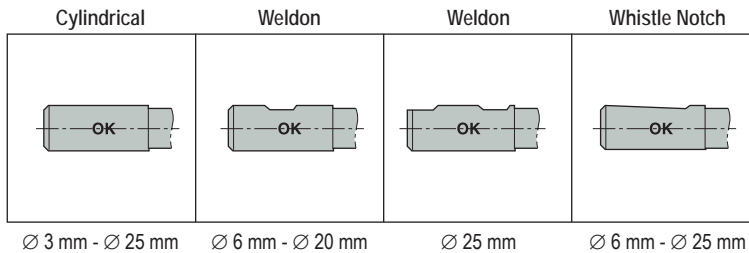

Reduction sleeves, range (see also chapter Additional equipment)

Tool shank ∅ mm	Reduction sleeves ∅ 12 mm	Reduction sleeves ∅ 20 mm	Reduction sleeves ∅ 32 mm
	Part No.	Part No.	Part No.
3	05F5832 12 03	05F5832 20 03	–
4	05F5832 12 04	05F5832 20 04	–
5	05F5832 12 05	05F5832 20 05	–
6	05F5832 12 06	05F5832 20 06	05F5832 32 06
8	05F5832 12 08	05F5832 20 08	05F5832 32 08
10	05F5832 12 10	05F5832 20 10	05F5832 32 10
12	–	05F5832 20 12	05F5832 32 12
14	–	05F5832 20 14	05F5832 32 14
16	–	05F5832 20 16	05F5832 32 16
18	–	–	05F5832 32 18
20	–	–	05F5832 32 20
25	–	–	05F5832 32 25

Hydraulic chucks, EPB 5834

A good choice for HSM and high precision. It is not recommended where high radial forces are involved due to its lower radial rigidity. An internal piston pressurises hydraulic fluid into a chamber surrounding the holder bore. The high pressure is uniformly applied to grip 360° around the tool shank. Cutting tools are held with excellent precision. The bore has a helical groove where dirt, oil or grease can collect when it has inadvertently been left on the tool shank. The pressurising screw must be completely tightened.
PLEASE NOTE: NEVER LOCK THE CHUCK WITHOUT A TOOL IN PLACE.

Types: EPB 5834 – DIN 69882-7 defines the overall dimensions of some HSK-A hydraulic chuck holder sizes, refer to the Product pages. For the other hydraulic chuck holder types and sizes this norm only applies to the front end.

Tool shanks: Cylindrical DIN 1835-1 Form A/ DIN 6535 Form HA, \varnothing 6 to 32 mm and Weldon DIN 1835-1 Form B/ DIN 6535 Form HB, \varnothing 6 to 20 mm.

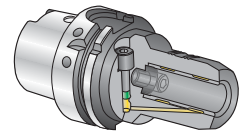
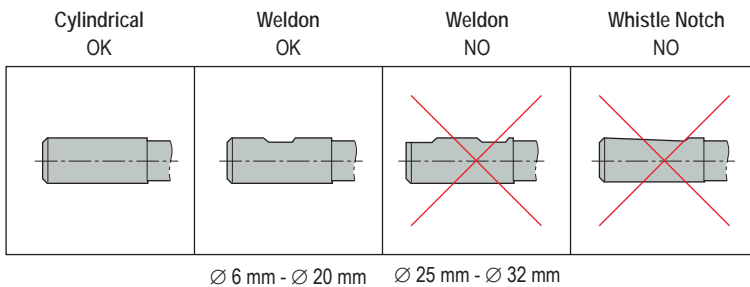

Shank tolerance
h6 maximum.

Run-out
Maximum run-out when measured at a gauge projection of 3 x d in relation to the external taper is 3 μ m.

Balancing
Fine-balanced as standard.

Clamp \varnothing (mm)	Minimum static transmittable torque (Nm)	Operating temperature	Max. coolant pressure	Hydraulic system Max RPM*
6	20	10-50° C	70 bar	40 000
8	30			40 000
10	40			40 000
12	70			40 000
14	100			40 000
16	120			40 000
18	140			40 000
20	170			40 000
25	200			25 000
32	250			25 000

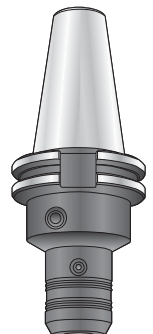

* The maximum RPM for holders equipped with this clamping system is often restricted by the holder's back-end taper type and size.
 To reach maximum transmittable torque, the tool shank and bore must be clean and dry.

ER collet chucks

- Types:** EPB 5675 – offers good flexibility thanks to the interchangeability of the collets.
The clamping range of an ER collet is up to 1 mm.
- Norm:** ISO 15488.
- Tool shanks:** Cylindrical DIN 1835-1 Form A/ DIN 6535 Form HA.
- Run-out:** Maximum run-out when measured with a collet at a gauge projection of $3 \times d$ in relation to the external taper is $10 \mu\text{m}$.
- Balancing:** See Product pages (1 = Fine balanced ; 2 = Pre-balanced).

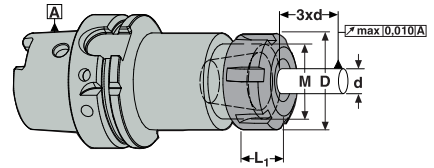

Recommended tightening torque for the locking nut

Collet chuck size	D	L ₁	M	Max tightening torque
ER16	32	18	M22 x 1,5	60 Nm
ER25	42	21	M32 x 1,5	110 Nm
ER32	50	23	M40 x 1,5	160 Nm
ER40	63	26	M50 x 1,5	180 Nm

Through coolant supply:

- There are two possibilities to direct the coolant through the tool shank coolant channel(s) when fitted into an ER collet chuck:
- by applying the concave front face of the stop end screw equipping the ER collet chucks onto the tool shank (for tool shanks without groove)
 - by using a sealing nut, available as Accessories, and a sealing ring, available as Additional equipment. Sealing nuts are slightly longer than standard nuts, see lengths listed in Product pages.

ER collet chuck extensions, with cylindrical shank, Additional equipment

- Types:** EPB 5450 – these collet chuck extensions have a cylindrical shank, tolerance h5.
They can be used where there is restricted access, when a long reach is required or to hold small tools. Extensions in sizes ER08R, ER11R, ER16R and ER25R are equipped with reduced diameter locking nuts.
- Norm:** ISO 15488.
- Tool shanks:** Cylindrical DIN 1835-1 Form A/ DIN 6535 Form HA.
- Run-out:** Maximum run-out when measured with a collet at a gauge projection of $3 \times d$ in relation to the to the cylindrical shank is $15 \mu\text{m}$ ($18 \mu\text{m}$ with the smallest ER 08).
- Balancing:** See Product pages.



Recommended tightening torque for the locking nut

Collet chuck size	D	L	M	Max tightening torque
ER08R	12	11	M10 x 0,75	12 Nm
ER11R	16	12	M13 x 0,75	25 Nm
ER16R	22	18	M19 x 1	35 Nm
ER25R	32	20	M30 x 1	45 Nm
ER32	50	23	M40 x 1,5	160 Nm

OZ collet chucks

Types: EPB 5873 – Flexibility thanks to the interchangeability of collets. Ball bearing type locking nut.

Norm: DIN 6388.

Tool shanks: Cylindrical DIN 1835-1 Form A/ DIN 6535 Form HA.

Run-out: Maximum run-out when measured with a collet and at a gauge projection of $3 \times d$ in relation to the external taper is $15 \mu\text{m}$ maximum, see OZ collets Guide and Product pages - Additional equipment.

Balancing: See Product pages.

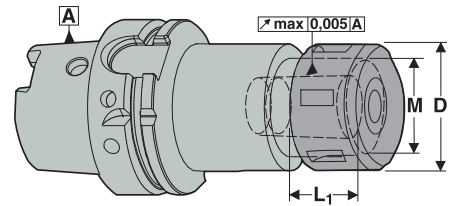

Recommended tightening torque for the locking nut

Collet chuck size	D	L ₁	M	Max tightening torque
OZ32	72	33,5	M60 x 2,5	140 Nm

Universal drill chucks

Types: EPB 5085 – Compact one piece design, allowing both CW or CCW spindle rotation. Clamping is made through a side access screw and gear mechanism.

Norm: No norm.

Tool shanks: Cylindrical DIN 1835-1 Form A/ DIN 6535 Form HA.

Run-out: Maximum run-out when measured at a gauge projection of $2,5 \times d$ in relation to the external taper is $40 \mu\text{m}$ for diameters from 2 mm. No run-out precision guarantee for diameters lower than 2 mm.

Balancing: See Product pages.

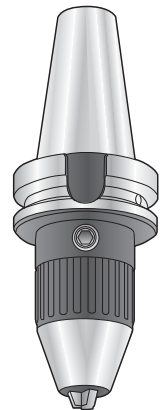

Tapping chucks with micro-compensation, for synchronized tapping, EPB 5867

EPB 5867 – Improves tapping performances during synchronized tapping. The inbuilt axial micro flexure (+/- 0,5 mm) prevents from tap stress, which may appear from micro-deviation of the synchronism between the spindle rotation, feed and tap pitch. That micro-compensation mechanism offers longer tap life, protects tap against breakage, increases productivity and improves thread quality.

Suitable ER tapping collets with square drive:
offering precise tap holding and positive torque transmission.

Tool shanks:
Cylindrical tap shanks with a square back-end.

Balancing:
Balanced by design.

Through coolant supply:
Chucks EPB 5867 feature a through coolant design. Maximum coolant pressure 80 bar.

Suitable sealing rings:
The chucks are delivered with collet clamping nuts allowing the fitting of sealing rings, available as Additional equipment.

The rings prevents coolant to flow though the collet's grooves, forcing coolant to flow through the tap's coolant channel.

Assembly instructions:
The use of two dedicated wrenches, available as Accessories (see Product Pages) will provide the recommended tightening torque (see table below) and is recommended to eliminate the risk of damaging the micro-compensation system or the tap driver: the wrench (Part No. 56800x2-xx) is used to maintain the micro-compensation mechanism in position while the locking wrench (Part No. 56800x1-xx for sizes ER 11 and ER 20, Part No. 5680096-xx for sizes ER 25 and 40) is used to tighten the nut. Do not tighten the nut without maintaining the micro-compensation mechanism in position, even if the EPB 5867 tapping chuck is maintained in a Tool Boy assembly support.



Recommended tightening torque for the ER tapping collet nuts

Tapping chuck size	Max. tightening torque
ER 11	30 Nm
ER 20	100 Nm
ER 25	130 Nm
ER 40	220 Nm

Quick change Tapping chucks

- Types:** EPB 5283 – Offers an axial feed compensation in extension and compression which protects the tap against breakage. Shown here.
Note: Type 5283 chucks are also available with Weldon/Whistle Notch combined back end shank, see Additional equipment.
- Types:** EPB 5260 – No axial compensation. Most machines on the market today are available with a standard option of rigid synchronized tapping.
- Norm:** No norm.
- Adapters:** Tap adapters, with or without torque limiter, see Additional equipment.
- Tool shanks:** DIN 374/376, DIN 371, ISO R529, PIPE.
- Balancing:** Pre balanced, cannot be fine balanced.

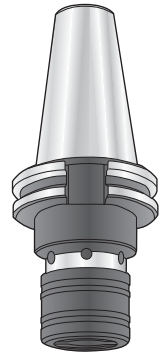

Assembly advice for the tap adapters:

Push the tap adapter into the chuck until it is locked automatically.
 To dismantle, push the front sleeve of the chuck to unlock and remove the tap adapter. In size 4, pulling the sleeve also unlocks the tap adapter.

ER tapping chucks

- Types:** EPB 5865 – For rigid synchronized tapping, with ER collets, offering flexibility, and precise tap holding. The square clamping system is based on two driving jaws, the tap square is clamped between the jaws, while the cylindrical shank is clamped into the ER collet.
- Norm:** No norm.
- Tool shanks:** All cylindrical tap shanks with a square back end.
- Balancing:** See Product pages.
- Through coolant supply:**
 By using a sealing nut, available as Accessories, and a sealing ring, available as Additional equipment. Sealing nuts are slightly longer than standard nuts, see lengths listed in Product pages.

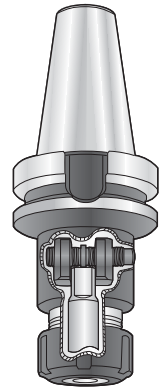

Adjustable drill holders

- Types:** EPB BM/6100-6101 – These holders allow SECO Performax™ drills to be radially offset from centre.
 Available for R7 drill shanks, ISO 9766, \varnothing 25, 32 and 40.
 Reduction sleeves are available as Accessories.
- Norm:** No norm.
- Run-out:** Offset is adjusted by rotating the holder's internal sleeve and then locking.
 – Adjustable +0,8 to -0,3 mm on diameter.
 – Adjustability graduations in increments of 0,05 mm on diameter.
 – Maximum radial adjustment for the drills is shown in Machining Navigator Holemaking.
- Balancing:** Not suitable for balancing due to the sleeve rotation.

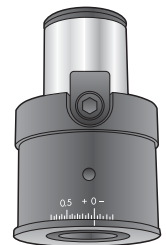

Greenstock blanks, available in Monobloc and Graflex®

Types:	<p>EPB 5023 – The taper/flange and Graflex® connection are case hardened and ground. The cylindrical front part 120 to 130 daN/mm² tensile strength it is not hardened and can be machined by the customer. Subsequent heat treatment is not recommended.</p>	
Norm:	<p>No norm. Used for special (custom-made) tooling.</p>	
Balancing:	<p>Not balanced.</p>	

Test/Control bars, available in Monobloc

Types:	<p>EPB 586 – Test bars are used primarily for checking the accuracy and to set the axes of the machine tool and tool presetter.</p>	
Norm:	<p>No norm.</p>	
Accuracy:	<p>Direct run-out between front part and taper 5 µm maximum. Measurement values are tabulated on the accompanying datasheet and certificate of accuracy.</p>	

1 2
586 40250
GB40 250
p 25/01
ø 40,007
± 250,11

586 40250
GB40 250
p 25/01
ø 40,007
± 250,11

1 2

Diameter and length measurement values are laser engraved on each test bar.

Measurement positions are laser engraved.

Delivered in a protective case.

The front leading edge can be used for optical presetting.

Rotary coolant inducers for drills, available in Graflex®

For machines not equipped with 'through the spindle' coolant, these inducers provide a way of delivering coolant through the drill. Inducers are available with Graflex® back end size 5 or 6.

Inducers are available in five types of front ends:

Type BSM/6181-6183: For Type 7 drill shanks, ISO 9766 (Weldon compatible). Reduction sleeves are available, see Accessories.

Type BSM/6100-6101: for Perfomax™ drills with Type 7 shanks, adjustable +0,8 to -0,3 mm on Ø.

Type BSM/401: for Graflex® modular system modules.

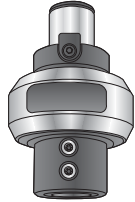

Manual inducers:

Connection to the coolant feed pipe has to be made manually after every holder change.

Inducers for automatic tool change:

The inducer has an indexable and compressible connecting pipe. The pipe connects to a coolant supply socket mounted on the machine tool spindle housing during the automatic tool change procedure. Before use, the connecting pipe has to be shortened to the required length.

Pipe orientation has to be set in line with the socket position.

For application details, e.g. pipe shortening procedure, refer to the instruction sheet supplied with the inducers.

Spare connecting pipes are available, the same pipe is suitable for all inducers shown in the catalogue:

Part No: EU9023001.

If not already fitted to the machine, the coolant supply socket has to be ordered and fitted.

The socket is available as Accessories: Part No. E99000.

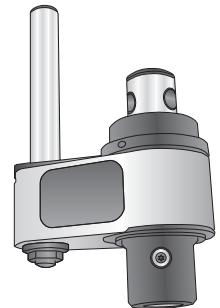

Application note: (also marked on the inducer body):

Max. coolant supply pressure: 20 bar (240 psi).

Never run the inducer without coolant.

Max. speed: 4000 or 6000 rpm, depending on the inducer's size (shown on Product pages).

Coolant to be filtered to 40 µm maximum.

Balancing: Not suitable for balancing.





- With expandable hydraulic spigot
- Direct run-out 5 µm maximum
- With coolant supply channels through the spigot

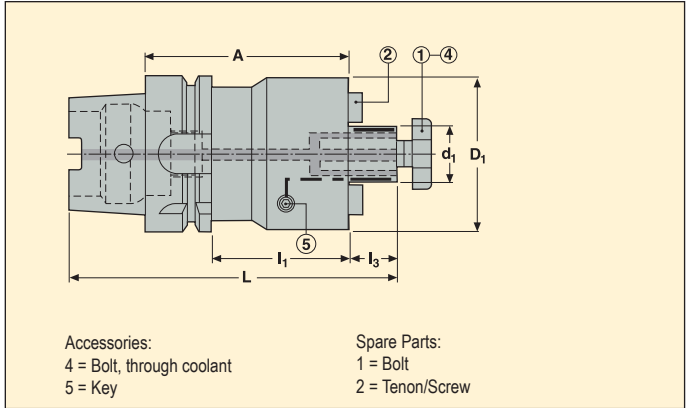

Taper	d ₁ mm	Part No.	Dimensions in mm					*	Balancing	KG
			A	D ₁	L	l ₁	l ₃			
HSK-A63	22	E930455452250	50	48	101	24	19		1	1,00
	27	E930455452760	60	60	113	34	21		1	1,37
	32	E930455453260	60	78	116	34	24		1	1,69
HSK-A100	22	E930655452255	55	48	124	26	19	*	1	2,35
	27	E930655452750	50	60	121	21	21		1	2,50
	32	E930655453250	50	78	124	21	24		1	2,89

* Length A (55) on type 5545 is longer than on type 5525 (50)

Accessories

Spare Parts

For d ₁	Bolt, through coolant	Key	Spanner
22	5802210L	H04-4	5812210
27	5802712L	H04-4	5812712
32	5803216L	H04-4	5813216

For d ₁	Bolt	Screw	Tenon
22	5802210	951D0416	16C2101111
27	5802712	951D0508	16C2121214
32	5803216	951D0516	16C2141421

Please check availability in current price and stock-list
 For HSK sealing plugs, coolant tubes and tube spanners, see page(s) 287



- With dynamic damping, ready to use
- Direct run-out 5 µm maximum
- With coolant supply channels through the spigot

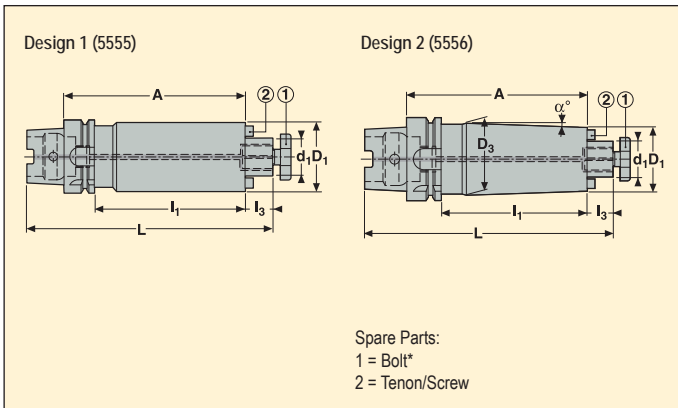

Taper	d ₁ mm	Part No.	Dimensions in mm						Design	α°	Balancing	
			A	D ₁	D ₃	L	I ₁	I ₃				
HSK-A63	16	E9304555516160	160	38	–	209	134	17	1	–	2	2,40
	22	E9304555522210	210	48	–	261	184	19	1	–	2	3,54
	22	E9304555522260	260	48	63,3	311	234	19	2	1,9	2	5,38
	27	E9304555527260	260	60	–	313	234	21	1	–	2	6,56
HSK-A100	22	E9306555522210	210	48	–	279	181	19	1	–	2	4,80
	22	E9306555522260	260	48	65,0	329	231	19	2	1,9	2	6,78
	27	E9306555527260	260	60	–	331	231	21	1	–	2	7,92
	27	E9306555527320	320	60	82,0	391	291	21	2	2,0	2	11,86
	32	E9306555532330	330	78	–	404	301	24	1	–	2	14,42
	40	E9306555540350	350	89	–	424	321	27	1	–	2	19,40

d₁ 40, includes 4 threaded holes on the bearing face according to DIN 6357

Accessories

For d ₁	Spanner
16	5811608
22	5812210
27	5812712
32	5813216
40	5814020

Spare Parts*

For d ₁	Bolt	Screw	Tenon
16	5801608	951D0312	16C2080810A
22	5802210	951D0416	16C2101111
27	5802712	951D0516	16C2121214A
32	5803216	951D0516	16C2141421A
40	5804020	951D0616	16C2161621A

Please check availability in current price and stock-list

* These centre bolts are similar to the original delivered ones: check if lengths L are suitable for the milling cutters used, therefore see instructions in catalogue's Guide pages or in the Operating instructions sheet delivered with the holders.



- Direct run-out 5 µm maximum
- With coolant supply channels through the spigot

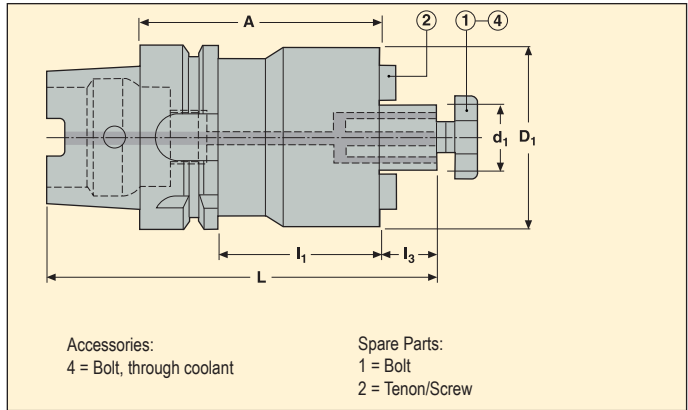

Taper	d ₁ mm	Part No.	Dimensions in mm					*	**	Balancing		
			A	D ₁	L	l ₁	l ₃					
HSK-A63	16	E930455251650	50	38	99	24	17			1	0,88	
	16	E9304552516100	100	38	149	74	17			1	1,31	
	16	E9304552516145	145	38	194	119	17			1	1,70	
	22	E930455252250	50	48	101	24	19	*		1	1,08	
	22	E9304552522100	100	48	151	74	19			1	1,72	
	22	E9304552522160	160	48	211	134	19			1	2,54	
	27	E930455252760	60	60	113	34	21	*	**	1	1,38	
	27	E9304552527100	100	60	153	74	21			1	2,23	
	27	E9304552527160	160	60	213	134	21			1	3,54	
	32	E930455253260	60	78	116	34	24	*		1	1,75	
	32	E9304552532100	100	78	156	74	24			1	2,93	
	40	E930455254060	60	89	119	34	27	*		1	2,02	
		27	E930455242760	60	48	113	34	21	*	**	1	1,20

d₁ 40, includes 4 threaded holes on the bearing face according to DIN 6357

* Conform to DIN 69882-3

** Diameter D₁ on type 5524 is smaller than on type 5525

Accessories

For d ₁	Bolt, through coolant	Spanner
16	5801608L	5811608
22	5802210L	5812210
27/5524	5802712L	5812712
27/5525	5802712L	5812712
32	5803216L	5813216
40	5804020L	5814020

Spare Parts

For d ₁	Bolt	Screw	Tenon
16	5801608	950D0312	16C10810164
22	5802210	950D0416	16C11012206
27/5524	5802712	951D0512	16C127
27/5525	5802712	951D0516	16C11214243
32	5803216	951D0516	16C2141421
40	5804020	951D0616	16C2161621

Please check availability in current price and stock-list

For HSK sealing plugs, coolant tubes and tube spanners, see page(s) 287



- Direct run-out 5 μ m maximum
- With coolant supply channels through the spigot

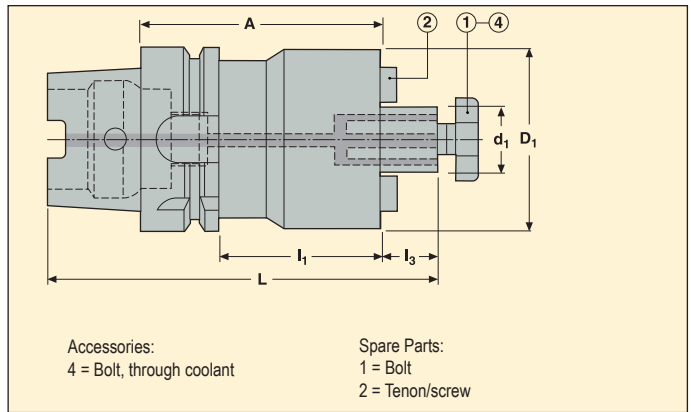

Taper	d ₁ mm	Part No.	Dimensions in mm					*	**	Balancing		
			A	D ₁	L	l ₁	l ₃					
HSK-A100	16	E9306552516100	100	38	167	71	17			1	2,58	
	22	E930655252250	50	48	119	21	19	*		1	2,35	
	22	E9306552522100	100	48	169	71	19			1	3,00	
	22	E9306552522160	160	48	229	131	19			1	3,82	
	27	E930655252750	50	60	121	21	21	*	**	1	2,53	
	27	E9306552527100	100	60	171	71	21			1	3,60	
	27	E9306552527160	160	60	231	131	21			1	4,87	
	32	E930655253250	50	78	124	21	24	*		1	2,96	
	32	E9306552532100	100	78	174	71	24			1	4,78	
	32	E9306552532160	160	78	234	131	24			1	6,98	
	40	E930655254060	60	89	137	31	27	*		1	3,64	
	40	E9306552540100	100	89	177	71	27			1	5,56	
	40	E9306552540160	160	89	237	131	27			1	8,41	
		27	E930655242750	50	48	121	21	21		**	1	2,36

d₁ 40, includes 4 threaded holes on the bearing face according to DIN 6357

* Conform to DIN 69882-3

** Diameter D₁ on type 5524 is smaller than on type 5525

Accessories

For d ₁	Bolt, through coolant	Spanner
16	5801608L	5811608
22	5802210L	5812210
27/5524	5802712L	5812712
27/5525	5802712L	5812712
32	5803216L	5813216
40	5804020L	5814020

Spare Parts

For d ₁	Bolt	Screw	Tenon
16	5801608	950D0312	16C10810164
22	5802210	950D0416	16C11012206
27/5524	5802712	951D0512	16C127
27/5525	5802712	951D0516	16C11214243
32	5803216	951D0516	16C2141421
40	5804020	951D0616	16C2161621

Please check availability in current price and stock-list

For HSK sealing plugs, coolant tubes and tube spanners, see page(s) 287



- Direct run-out 5 µm maximum
- Small front face diameter D_1 according to ISO 3937, suitable for Seco disc mill cutters Type B

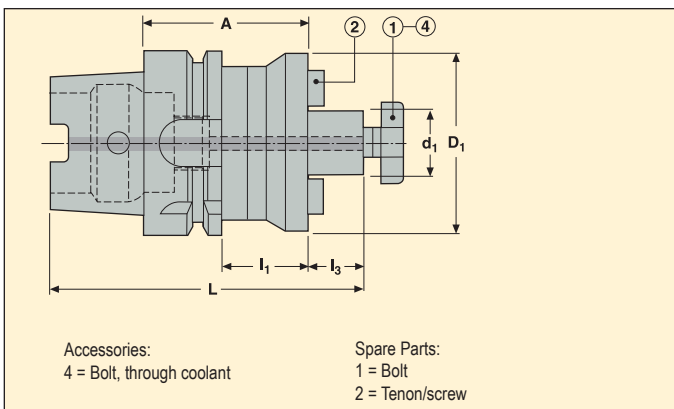

Taper	d_1 mm	Part No.	Dimensions in mm					Balancing	
			A	D_1	L	I_1	I_3		
HSK-A63	16	E93045521650	50	32	99	24	17	1	0.82
	22	E93045522250	50	40	101	24	19	1	0.94
	32	E93045523260	60	58	116	34	24	1	1.45
	40	E93045524060	60	70	119	34	27	1	1.80

Accessories

For d_1	Bolt, through coolant	Spanner
16	5801608L	5811608
22	5802210L	5812210
32	5803216L	5813216
40	5804020L	5814020

Spare Parts

For d_1	Bolt	Screw	Tenon
16	5801608	950D0308	16C116
22	5802210	951D0410	16C122
32	5803216	950E0512	16C13201
40	5804020	951D0616	16C2161613

Please check availability in current price and stock-list
For HSK sealing plugs, coolant tubes and tube spanners, see page(s) 287

EPB 5525 – Axiaset™, shell mill holders

HSK-A/ ISO 12164-1-A



- Length adjustment stroke 3 mm
- For e.g. multi-spindle applications
- Direct run-out 50 μm maximum
- With coolant supply multi-channels through the spigot

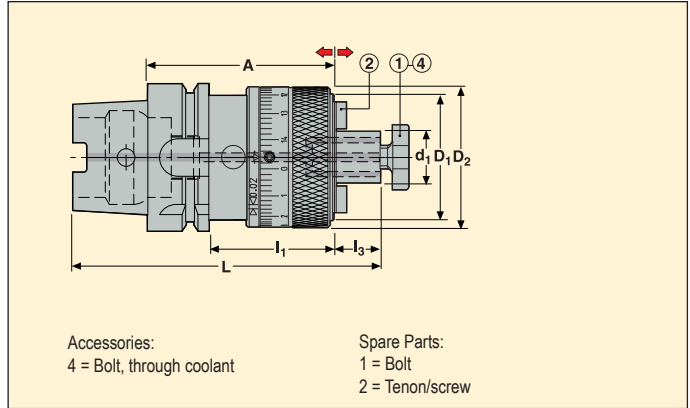

Taper	d ₁ mm	Part No.	Dimensions in mm						Balancing	 KG
			A*	D ₁	D ₂	L	I ₁	I ₃		
HSK-A63	16	EX9304552516080	80	38	60	129	54	17	2	1,74
	22	EX9304552522080	80	48	60	131	54	19	2	1,78
HSK-A100	22	EX9306552522090	90	48	60	159	61	19	2	3,24
	27	EX9306552527100	100	60	70	171	71	21	2	3,98

* A nominal (adjustable +/- 1.5 mm)

Accessories

For d ₁	Bolt, through coolant	Spanner
16	5801608L	5811608
22	5802210L	5812210
27	5802712L	5812712

Spare Parts

For d ₁	Bolt	Screw	Tenon
16	5801608	951D0312	16C2080810
22	5802210	951D0410	16C2100911
27	5802712	951D0512	16C2121214

Please check availability in current price and stock-list
For HSK sealing plugs, coolant tubes and tube spanners, see page(s) 287

Monobloc holders HSK-A

EPB 569 – Milling cutter holders, flange mounting – DIN 6357/ DIN 2079

HSK-A/ISO 12164-1-AD



- Direct run-out $5\ \mu\text{m}$ maximum

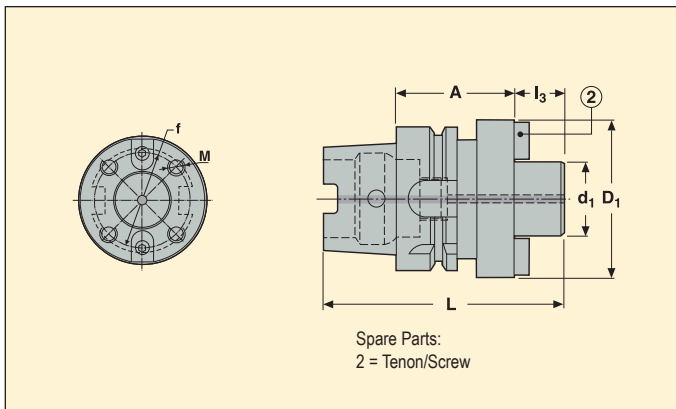

Taper	d ₁ mm	Part No.	Dimensions in mm					M mm	Balancing	
			A	D ₁	L	l ₃	f			
HSK-A100	60	E93065696075	75	129	165	40	101,6	M16	2	6,70

Spare Parts

For d ₁	Screw	Tenon
60	951D1225	16C35060

Please check availability in current price and stock-list
For HSK sealing plugs, coolant tubes and tube spanners, see page(s) 287

EPB 5657 – Disc mill holders



- With adjustable slide rod
- Best suitable for Seco disc mill cutters Type A

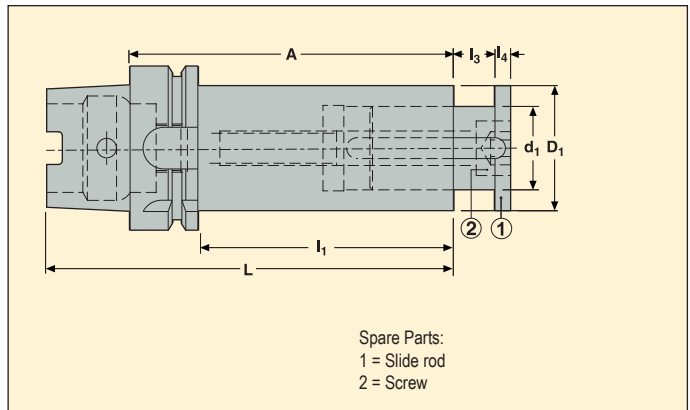

Taper	d ₁ mm	Part No.	Dimensions in mm						Balancing	
			A	D ₁	L	I ₁	I ₃	I ₄		
HSK-A63	22	E930456572290	90	35	122	64	0-12	4	2	1,13
	27	E9304565727120	120	42	152	94	0-15	5	2	1,66
	32	E9304565732150	150	48	182	124	0-24	6	2	2,39
HSK-A100	27	E9306565727120	120	42	170	91	0-15	5	2	2,96
	32	E9306565732155	155	48	205	126	0-24	6	2	3,76
	40	E9306565740190	190	58	240	161	0-30	7	2	5,30
	50	E9306565750235	235	72	285	206	0-32	8	2	8,44
	60	E9306565760255	255	90	305	226	0-40	8	2	13,24

Spare Parts

For d ₁	Screw	Slide rod
22	19C565722	565722
27	19C565727	565727
32	950D1690	565732
40	19C565740	565740
50	19C565750	565750
60	19C565760	565760

Please check availability in current price and stock-list
For HSK sealing plugs, coolant tubes and tube spanners, see page(s) 287



- Direct run-out 3 µm maximum
- Weldon d 16, 20, 25, 32 and 40 with ground face (Seco-Weldon compatible)

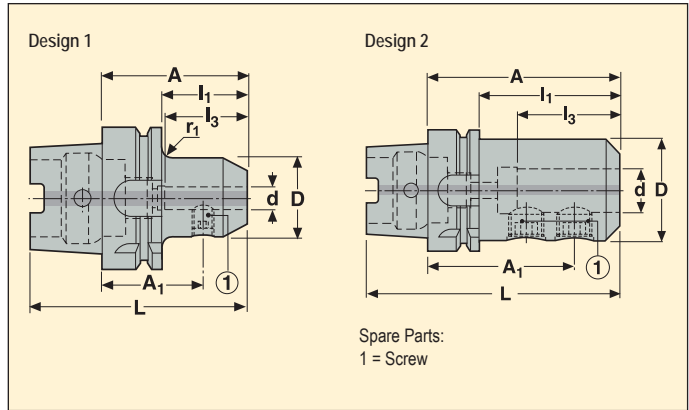

Taper	d mm	Part No.	Dimensions in mm						*	r ₁	Design	Balancing	
			A	D	L	I ₁	I ₃	A ₁					
HSK-A63	6	E93045840665	65	25	97	39	27	47,5	*	3	1	1	0,85
	8	E93045840865	65	28	97	39	30	47,5	*	3	1	1	0,80
	8	E930458408120	120	28	152	94	30	102,5		3	1	1	1,05
	10	E93045841065	65	35	97	39	36	45,5	*	3	1	1	0,90
	10	E930458410120	120	35	152	94	36	100,5		3	1	1	1,30
	12	E93045841280	80	42	112	54	43	58,0	*	3	1	1	1,15
	12	E930458412120	120	42	152	94	43	98,0		3	1	1	1,55
	14	E93045841480	80	44	112	54	43	58,0	*	3	1	1	1,20
	16	E93045841680	80	48	112	54	46	56,5	*	3	1	1	1,25
	16	E930458416120	120	48	152	94	46	96,5		2,5	1	1	1,85
	18	E93045841880	80	50	112	54	46	56,5	*	<2	1	1	1,35
	20	E93045842080	80	52	112	54	48	55,5	*	<2	1	1	1,35
	20	E930458420120	120	52	152	94	48	95,5		<2	1	1	2,00
	25	E930458425110	110	63	142	–	54	86,5	*	–	2	2	2,25
	32	E930458432110	110	72	142	–	58	86,5	*	–	2	2	2,55

Balancing 1, with steel shank

* Conform to DIN 69882-4

Spare Parts

For d	Locking screw
6	951C0610
8	951C0810
10	951C1012
12-14	951C1216
16-18	951C1416
20	951C1616
25	951C1820
32	951C2020

Please check availability in current price and stock-list

For HSK sealing plugs, coolant tubes and tube spanners, see page(s) 287

Monobloc holders HSK-A



EPB 584 – Side lock holders, Weldon – DIN 1835 Form B/ DIN 6535 Form HB

HSK-A/ ISO 12164-1-A



- Direct run-out 3 µm maximum
- Weldon d 16, 20, 25, 32 and 40 with ground face (Seco-Weldon compatible)

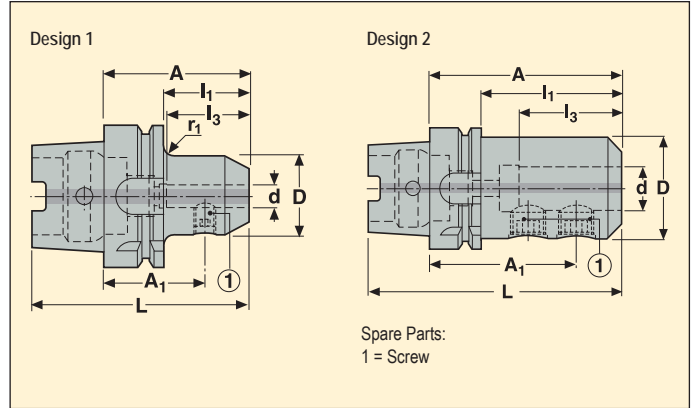

Taper	d mm	Part No.	Dimensions in mm						*	r ₁	Design	Balancing	
			A	D	L	I ₁	I ₃	A ₁					
HSK-A100	6	E93065840680	80	25	130	51	27	62,5	*	15	1	1	2,20
	8	E93065840880	80	28	130	51	30	62,5	*	10	1	1	2,25
	10	E93065841080	80	35	130	51	36	60,5	*	5	1	1	2,35
	12	E93065841280	80	42	130	51	43	58,0	*	5	1	1	2,45
	14	E93065841480	80	44	130	51	43	58,0	*	5	1	1	2,50
	16	E930658416100	100	48	150	71	46	76,5	*	5	1	1	2,85
	16	E930658416160	160	48	210	131	46	136,5		5	1	1	3,65
	18	E930658418100	100	50	150	71	46	76,5	*	5	1	1	2,95
	20	E930658420100	100	52	150	71	48	76,5	*	5	1	1	3,00
	20	E930658420160	160	52	210	131	48	135,5		5	1	1	3,95
	25	E930658425100	100	65	150	71	54	76,5	*	5	2	1	3,50
	25	E930658425160	160	65	210	131	54	136,5		5	2	1	5,00
	32	E930658432100	100	72	150	71	58	76,5	*	5	2	1	3,70
	32	E930658432160	160	72	210	131	58	136,5		5	2	1	5,60
	40	E930658440120	120	80	170	91	68	90,5		5	2	1	4,70

Balancing 1, with steel shank

* Conform to DIN 69882-4

Spare Parts

For d	Locking screw
6	951C0610
8	951C0810
10	951C1012
12-14	951C1216
16-18	951C1416
20	951C1616
25	951C1820
32	951C2020
40	951C2020

Please check availability in current price and stock-list

For HSK sealing plugs, coolant tubes and tube spanners, see page(s) 287



- Run-out 3 µm at 3xd (direct run-out 3 µm) maximum
- Delivered with one stop screw

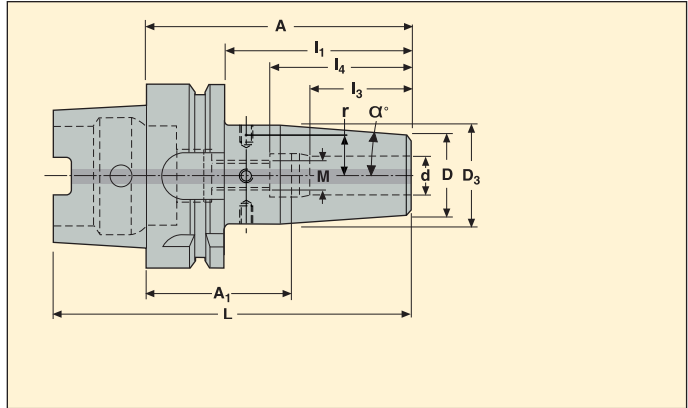

Taper	d mm	Part No.	Dimensions in mm								M mm	α°	r mm	*	Balancing	KG	
			A	D	D ₃	L	I ₁	I ₃	I ₄	A ₁ min-max							
HSK-A40	6	E930256030680	80	21	27	100	60	22	37,5	44-54	M5	4,5	10,5	*	1	0,40	
	8	E930256030880	80	21	27	100	60	26	37,5	44-54	M6	4,5	10,5	*	1	0,40	
	10	E930256031080	80	24	32	100	60	31	42,5	39-49	M8x1	4,5	13,0	*	1	0,45	
	12	E930256031290	90	24	32	110	70	34	47,5	44-54	M10x1	4,5	13,0	*	1	0,49	
	16	E930256031690	90	27	34	110	70	39	50,5	41-51	M12x1	4,5	14,0	*	1	0,51	
HSK-A63	6	E930456030680	80	21	27	112	54	22	37,5	44-54	M5	4,5	10,5	*	1	0,82	
	6	E9304560306120	120	21	27	152	94	22	37,5	84-94	M5	4,5	10,5		1	0,99	
	6	E9304560306160	160	21	27	192	134	22	37,5	124-134	M5	4,5	10,5		1	1,16	
	8	E930456030880	80	21	27	112	54	26	37,5	44-54	M6	4,5	10,5	*	1	0,81	
	8	E9304560308120	120	21	27	152	94	26	37,5	84-94	M6	4,5	10,5		1	0,98	
	8	E9304560308160	160	21	27	192	134	26	37,5	124-134	M6	4,5	10,5		1	1,15	
	10	E930456031085	85	24	32	117	59	31	42,5	44-54	M8x1	4,5	13,0	*	1	0,89	
	10	E9304560310120	120	24	32	152	94	31	42,5	79-89	M8x1	4,5	13,0		1	1,10	
	10	E9304560310160	160	24	32	192	134	31	42,5	119-129	M8x1	4,5	13,0		1	1,34	

For Shrinkfit extensions, see page(s) 294

* Conform to DIN 69882-8

Accessories

For d	Balancing screws
6	90ZQ01
8	90ZQ01
10	90ZQ01
12	90ZQ01
16	90ZQ01

Spare Parts

For d	Stop screw
6	19BDR05165
8	19BDR06165
10	19BDR08165
12	19BDR10165
16	19BDR12165

Please check availability in current price and stock-list

For stop screw setting adapters, see page(s) 336

For HSK sealing plugs, coolant tubes and tube spanners, see page(s) 287



- Run-out 3 µm at 3xd (direct run-out 3 µm) maximum
- Delivered with one stop screw

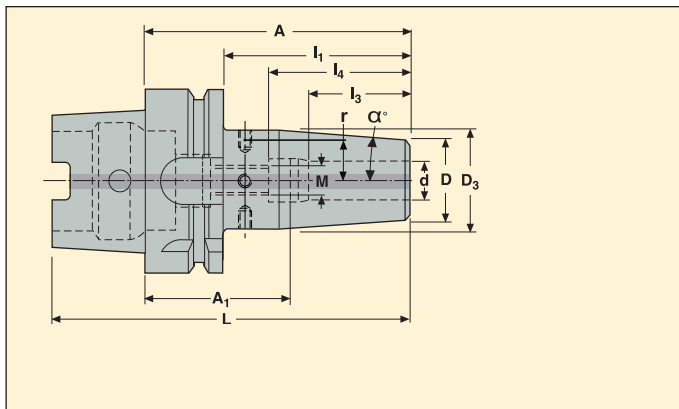

Taper	d mm	Part No.	Dimensions in mm								M mm	α°	r mm	*	Balancing	
			A	D	D ₃	L	I ₁	I ₃	I ₄	A ₁ min-max						
HSK-A63	12	E930456031290	90	24	32	122	64	34	47,5	44-54	M10x1	4,5	13,0	*	1	0,90
	12	E9304560312120	120	24	32	152	94	34	47,5	74-84	M10x1	4,5	13,0		1	1,07
	12	E9304560312160	160	24	32	192	134	34	47,5	114-124	M10x1	4,5	13,0		1	1,31
	14	E930456031490	90	27	34	122	64	34	47,5	44-54	M10x1	4,5	14,0	*	1	0,94
	14	E9304560314120	120	27	34	152	94	34	47,5	74-84	M10x1	4,5	14,0		1	1,15
	16	E930456031695	95	27	34	127	69	39	50,5	46-56	M12x1	4,5	14,0	*	1	0,95
	16	E9304560316120	120	27	34	152	94	39	50,5	71-81	M12x1	4,5	14,0		1	1,12
	16	E9304560316160	160	27	34	192	134	39	50,5	111-121	M12x1	4,5	14,0		1	1,39
	18	E930456031895	95	33	42	127	69	39	50,5	46-56	M12x1	4,5	18,0	*	1	1,13
	18	E9304560318120	120	33	42	152	94	39	50,5	71-81	M12x1	4,5	18,0		1	1,38
	20	E9304560320100	100	33	42	132	74	41	52,5	49-59	M16x1	4,5	18,0	*	1	1,13
	20	E9304560320120	120	33	42	152	94	41	52,5	69-79	M16x1	4,5	18,0		1	1,33
	20	E9304560320160	160	33	42	192	134	41	52,5	109-119	M16x1	4,5	18,0		1	1,74
	25	E9304560325115	115	44	53	147	89	47	58,5	58-68	M16x1	4,5	23,5	*	1	1,71
	25	E9304560325160	160	44	53	192	134	47	58,5	103-113	M16x1	4,5	23,5		1	2,47
	32	E9304560332120	120	44	53	152	94	51	62,5	59-69	M16x1	4,5	23,5	*	1	1,64

For Shrinkfit extensions, see page(s) 294

* Conform to DIN 69882-8

Accessories

For d	Balancing screws
12-14	90ZQ01
16-18	90ZQ01
20-32	90ZQ01

Spare Parts

For d	Stop screw
12-14	19BDR10165
16-18	19BDR12165
20-32	19BDR16165

Please check availability in current price and stock-list

For stop screw setting adapters, see page(s) 336

For HSK sealing plugs, coolant tubes and tube spanners, see page(s) 287



- Run-out 3 µm at 3xd (direct run-out 3 µm) maximum
- Delivered with one stop screw

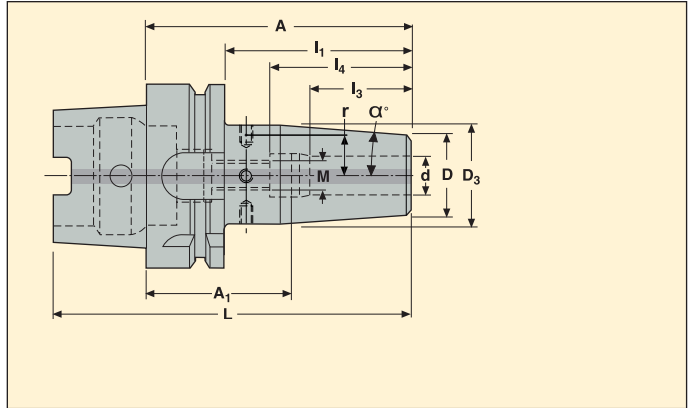

Taper	d mm	Part No.	Dimensions in mm								M mm	α°	r mm	*	Balancing	KG
			A	D	D ₃	L	I ₁	I ₃	I ₄	A ₁ min-max						
HSK-A100	6	E930656030685	85	21	27	135	56	22	37,5	49-59	M5	4,5	10,5	*	1	2,15
	6	E9306560306120	120	21	27	170	91	22	37,5	84-94	M5	4,5	10,5		1	2,29
	6	E9306560306160	160	21	27	210	131	22	37,5	124-134	M5	4,5	10,5		1	2,46
	8	E930656030885	85	21	27	135	56	26	37,5	49-59	M6	4,5	10,5	*	1	2,14
	8	E9306560308120	120	21	27	170	91	26	37,5	84-94	M6	4,5	10,5		1	2,29
	8	E9306560308160	160	21	27	210	131	26	37,5	124-134	M6	4,5	10,5		1	2,44
	10	E930656031090	90	24	32	140	61	31	42,5	49-59	M8x1	4,5	13,0	*	1	2,22
	10	E9306560310120	120	24	32	170	91	31	42,5	79-89	M8x1	4,5	13,0		1	2,40
	10	E9306560310160	160	24	32	210	131	31	42,5	119-129	M8x1	4,5	13,0		1	2,63

For Shrinkfit extensions, see page(s) 294

* Conform to DIN 69882-8

Accessories

For d	Balancing screws
6	90ZQ01
8	90ZQ01
10	90ZQ01

Spare Parts

For d	Stop screw
6	19BDR05165
8	19BDR06165
10	19BDR08165

Please check availability in current price and stock-list

For stop screw setting adapters, see page(s) 336

For HSK sealing plugs, coolant tubes and tube spanners, see page(s) 287



- Run-out 3 μm at 3xd (direct run-out 3 μm) maximum
- Delivered with one stop screw

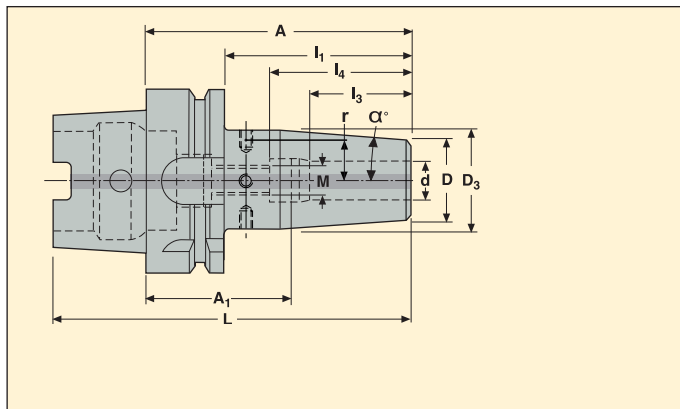

Taper	d mm	Part No.	Dimensions in mm								M mm	α°	r mm	*	Balancing	
			A	D	D ₃	L	I ₁	I ₃	I ₄	A ₁ min-max						
HSK-A100	12	E930656031295	95	24	32	145	66	34	47,5	49-59	M10x1	4,5	13,0	*	1	2,23
	12	E9306560312120	120	24	32	170	91	34	47,5	74-84	M10x1	4,5	13,0		1	2,37
	12	E9306560312160	160	24	32	210	131	34	47,5	114-124	M10x1	4,5	13,0		1	2,61
	14	E930656031495	95	27	34	145	66	34	47,5	49-59	M10x1	4,5	14,0	*	1	2,28
	16	E9306560316100	100	27	34	150	71	39	50,5	51-61	M12x1	4,5	14,0	*	1	2,29
	16	E9306560316130	130	27	34	180	101	39	50,5	81-91	M12x1	4,5	14,0		1	2,48
	16	E9306560316160	160	27	34	210	131	39	50,5	111-121	M12x1	4,5	14,0		1	2,68
	18	E9306560318100	100	33	42	150	71	39	50,5	51-61	M12x1	4,5	18,0	*	1	2,47
	20	E9306560320105	105	33	42	155	76	41	52,5	54-64	M16x1	4,5	18,0	*	1	2,48
	20	E9306560320130	130	33	42	180	101	41	52,5	79-89	M16x1	4,5	18,0		1	2,80
	20	E9306560320160	160	33	42	210	131	41	52,5	109-119	M16x1	4,5	18,0		1	3,02
	25	E9306560325115	115	44	53	165	86	47	58,5	58-68	M16x1	4,5	23,5	*	1	3,00
	25	E9306560325160	160	44	53	210	131	47	58,5	103-113	M16x1	4,5	23,5		1	3,80
	32	E9306560332120	120	44	53	170	91	51	62,5	59-69	M16x1	4,5	23,5	*	1	3,00

For Shrinkfit extensions, see page(s) 294

* Conform to DIN 69882-8

Accessories

For d	Balancing screws
12-14	90ZQ01
16-18	90ZQ01
20-32	90ZQ01

Spare Parts

For d	Stop screw
12-14	19BDR10165
16-18	19BDR12165
20-32	19BDR16165

Please check availability in current price and stock-list

For stop screw setting adapters, see page(s) 336

For HSK sealing plugs, coolant tubes and tube spanners, see page(s) 287



- Reinforced design with wider front and tapered body
- Run-out 3 µm maximum at 3xd
- With coolant supply channels towards the tool (plugged)

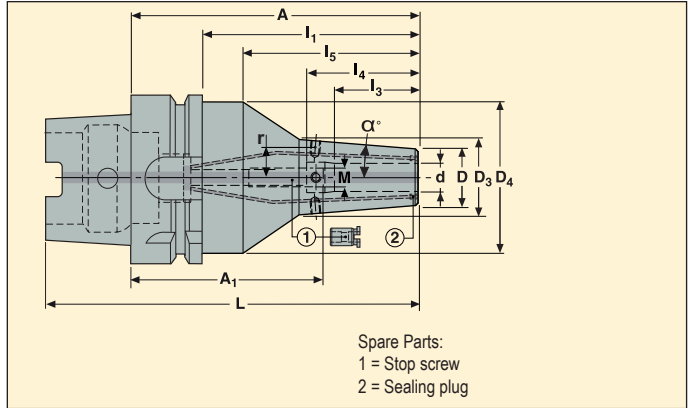

Taper	d mm	Part No.	Dimensions in mm											M mm	α°	**	r mm	***	Balancing	
			A*	D	D ₃	D ₄	L	I ₁	I ₃	I ₄	I ₅	A ₁ min-max								
HSK-A63	6	E930456000670	70	24	31,0	–	102	44	22	37,5	–	–	–	–	4,5	**	12,0	1	0,85	
	6	E9304560006130	130	24	32,2	52,5	162	104	22	37,5	88	94-104	M5	4,5	–	12,0	1	1,55		
	6	E9304560006160	160	24	32,2	52,5	192	134	22	37,5	118	124-134	M5	4,5	–	12,0	1	1,90		
	8	E930456000870	70	24	31,0	–	102	44	26	37,5	–	–	–	–	4,5	**	12,0	1	0,85	
	8	E9304560008130	130	24	32,2	52,5	162	104	26	37,5	88	94-104	M6	4,5	–	12,0	1	1,55		
	8	E9304560008160	160	24	32,2	52,5	192	134	26	37,5	118	124-134	M6	4,5	–	12,0	1	1,90		
	10	E930456001070	70	27	34,0	–	102	44	31	42,5	–	–	–	–	4,5	**	13,5	1	0,85	
	10	E9304560010130	130	27	35,2	52,5	162	104	31	42,5	88	89-99	M8x1	4,5	–	13,5	1	1,60		
	10	E9304560010160	160	27	35,2	52,5	192	134	31	42,5	118	119-129	M8x1	4,5	–	13,5	1	1,95		
	12	E930456001270	70	27	33,9	–	102	44	34	46,0	–	–	–	–	4,5	**	13,5	1	0,85	
	12	E9304560012130	130	27	35,2	52,5	162	104	34	47,5	88	84-94	M10x1	4,5	–	13,5	1	1,60		
	12	E9304560012160	160	27	35,2	52,5	192	134	34	47,5	118	114-124	M10x1	4,5	–	13,5	1	1,95		
	16	E930456001675	75	33	40,8	–	107	49	39	50,5	–	–	–	–	4,5	**	17,0	1	1,00	
	16	E9304560016130	130	33	42,2	52,5	162	104	39	50,5	88	81-91	M12x1	4,5	–	17,0	1	1,70		
	16	E9304560016160	160	33	42,2	52,5	192	134	39	50,5	118	111-121	M12x1	4,5	–	17,0	1	2,15		
	20	E930456002075	75	44	51,7	–	107	49	41	50,5	–	–	–	–	4,5	**	21,5	1	1,19	
	20	E9304560020130	130	44	57,6	52,5	162	104	41	52,5	88	79-89	M16x1	4,5	–	21,5	1	2,12		
	20	E9304560020160	160	44	62,0	52,5	192	134	41	52,5	118	109-119	M16x1	4,5	–	21,5	1	2,74		
	25	E930456002585	85	48	56,5	52,5	117	59	47	58,5	43	–	–	–	4,5	**	–	***	1	1,41
	25	E9304560025130	130	48	63,0	52,5	162	104	47	58,5	88	73-83	M16x1	4,5	–	25,0	1	2,34		
	25	E9304560025160	160	48	63,0	52,5	192	134	47	58,5	118	103-113	M16x1	4,5	–	25,0	1	3,04		
	32	E930456003285	85	48	56,5	52,5	117	59	51	61,0	43	–	–	–	4,5	**	–	***	1	1,25

* If A = 70, 75 or 85: Extra-short holders requiring a dedicated cooling contact bush type "5600 extra short", see page(s) 337

** Holder without thread for a stop screw, *** Holder without threaded holes for balancing screw

Accessories

For d	Balancing screws
6	90ZQ01
8	90ZQ01
10	90ZQ01
12	90ZQ01
16	90ZQ01
20-32	90ZQ01

Spare Parts

For d	Sealing plugs	Stop screw
6	90AI03	19BDR05165
8	90AI03	19BDR06165
10	90AI03	19BDR08165
12	90AI03	19BDR10165
16	90AI03	19BDR12165
20-32	90AI04	19BDR16165

Please check availability in current price and stock-list

For stop screw setting adapters, see page(s) 334

For HSK sealing plugs, coolant tubes and tube spanners, see page(s) 287

EPB 5600 – Shrinkfit holders, reinforced

HSK-A/ ISO 12164-1-A



- Reinforced design with wider front and tapered body
- Run-out 3 µm maximum at 3xd
- With coolant supply channels towards the tool (plugged)

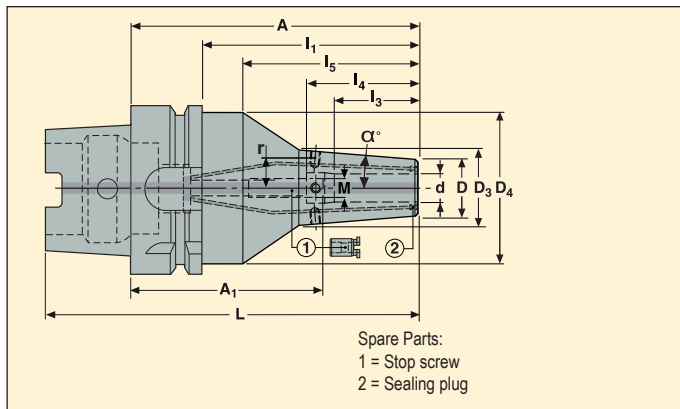

Taper	d mm	Part No.	Dimensions in mm											M mm	α°	r mm	Balancing	KG
			A	D	D ₃	D ₄	L	I ₁	I ₃	I ₄	I ₅	A ₁ min-max						
HSK-A100	6	E9306560006160	160	24	32,2	87,5	210	131	22	37,5	115	124-134	M5	4,5	12,0	1	4,45	
	8	E9306560008160	160	24	32,2	87,5	210	131	26	37,5	115	124-134	M6	4,5	12,0	1	4,45	
	10	E930656001090	90	27	36,6	–	140	61	31	42,5	–	49-59	M8x1	4,5	13,5	1	2,35	
	10	E9306560010160	160	27	35,2	87,5	210	131	31	42,5	115	119-129	M8x1	4,5	13,5	1	4,55	
	10	E9306560010200	200	27	35,2	87,5	250	171	31	42,5	155	159-169	M8x1	4,5	13,5	1	5,50	
	12	E930656001295	95	27	37,4	–	145	66	34	47,5	–	49-59	M10x1	4,5	13,5	1	2,40	
	12	E9306560012160	160	27	35,2	87,5	210	131	34	47,5	115	114-124	M10x1	4,5	13,5	1	4,50	
	12	E9306560012200	200	27	35,2	87,5	250	171	34	47,5	155	154-164	M10x1	4,5	13,5	1	5,50	
	16	E9306560016100	100	33	44,2	–	150	71	39	50,5	–	51-61	M12x1	4,5	17,0	1	2,55	
	16	E9306560016160	160	33	42,2	87,5	210	131	39	50,5	115	111-121	M12x1	4,5	17,0	1	4,65	
	16	E9306560016200	200	33	42,2	87,5	250	171	39	50,5	155	151-161	M12x1	4,5	17,0	1	5,70	
	20	E9306560020105	105	44	56,0	–	155	76	41	52,5	–	54-64	M16x1	4,5	21,5	1	3,01	
	20	E9306560020160	160	44	53,1	87,5	210	131	41	52,5	115	109-119	M16x1	4,5	21,5	1	5,12	
	20	E9306560020200	200	44	53,1	87,5	250	171	41	52,5	155	149-159	M16x1	4,5	21,5	1	6,32	
	25	E9306560025115	115	48	59,1	87,5	165	86	47	58,5	70	58-68	M16x1	4,5	25,0	1	3,93	
	25	E9306560025160	160	48	59,1	87,5	210	161	47	58,5	115	103-113	M16x1	4,5	25,0	1	5,37	
	25	E9306560025200	200	48	59,1	87,5	250	171	47	58,5	155	143-153	M16x1	4,5	25,0	1	6,67	
	32	E9306560032115	115	48	59,1	87,5	165	86	51	62,5	70	54-64	M16x1	4,5	25,0	1	3,75	
	32	E9306560032160	160	48	59,1	87,5	210	131	51	62,5	115	99-109	M16x1	4,5	25,0	1	5,20	

Accessories

For d	Balancing screws
6	90ZQ01
8	90ZQ01
10	90ZQ01
12	90ZQ01
16	90ZQ01
20-32	90ZQ01

Spare Parts

For d	Sealing plugs	Stop screw
6	90AI03	19BDR05165
8	90AI03	19BDR06165
10	90AI03	19BDR08165
12	90AI03	19BDR10165
16	90AI03	19BDR12165
20-32	90AI04	19BDR16165

Please check availability in current price and stock-list

For stop screw setting adapters, see page(s) 334

For HSK sealing plugs, coolant tubes and tube spanners, see page(s) 287



- With Safe-Lock™ tool pull-out protection system
- Reinforced design of EPB 5600
- Run-out 3 μm maximum at 3xd
- With coolant supply channels towards the tool (plugged)

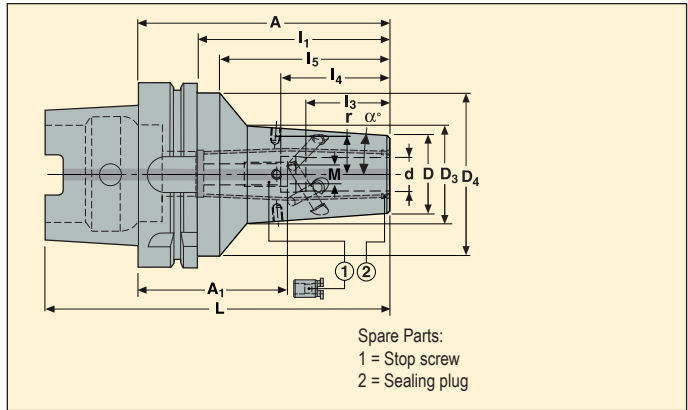

Taper	d mm	Part No.	Dimensions in mm										M mm	α°	**	r mm	***	Balancing	
			A*	D	D ₃	D ₄	L	I ₁	I ₃	I ₄	I ₅	A ₁ min-max							
HSK-A63	12	E930456001270P	70	27	33,9	-	102	44	34	46,0	-	-	-	4,5	**	13,5		1	0,85
	16	E930456001675P	75	33	40,8	-	107	49	39	50,5	-	-	-	4,5	**	17,0		1	1,00
	20	E930456002075P	75	44	51,7	-	107	49	41	50,5	-	-	-	4,5	**	21,5		1	1,19
	25	E930456002585P	85	48	56,5	-	117	59	47	58,5	-	-	-	4,5	**	-	***	1	1,41
HSK-A100	12	E930656001295P	95	27	37,4	-	145	66	34	47,5	-	49-57,5	M10x1	4,5		13,5		1	2,40
	16	E9306560016100P	100	33	44,2	-	150	71	39	50,5	-	51-59	M12x1	4,5		17,0		1	2,60
	20	E9306560020105P	105	44	56,0	-	155	76	41	52,5	-	54-62	M16x1	4,5		21,5		1	3,10
	25	E9306560025115P	115	48	57,1	87,5	165	86	47	58,5	70	58-66	M16x1	4,5		25,0		1	3,90
	32	E9306560032115P	115	48	57,2	87,5	165	86	51	62,5	70	54-64	M16x1	4,5		25,0		1	3,70

* If A = 70, 75 or 85 : Extra-short holders requiring a dedicated Easyshrink® cooling contact bush type "5600 extra short", see page(s) 337

** Holder without thread for a stop screw nor a stop end screw, *** Holder without threaded holes for balancing screws

Accessories

For d	Balancing screws
12-16	90ZQ01
20-32	90ZQ01

Spare Parts

For d	Sealing plugs	Stop screw
12-16	90AI03	-
20-32	90AI04	19BDR16165

Please check availability in current price and stock-list

(-) For Ø 12 and 16 mm, stop screw not removable/replaceable by the user, please request a repair process

EPB 5801 – Shrinkfit holders, Mould and Die type

HSK-A/ ISO 12164-1-A



- Run-out 3 μm at 3xd (direct run-out 3μm) maximum

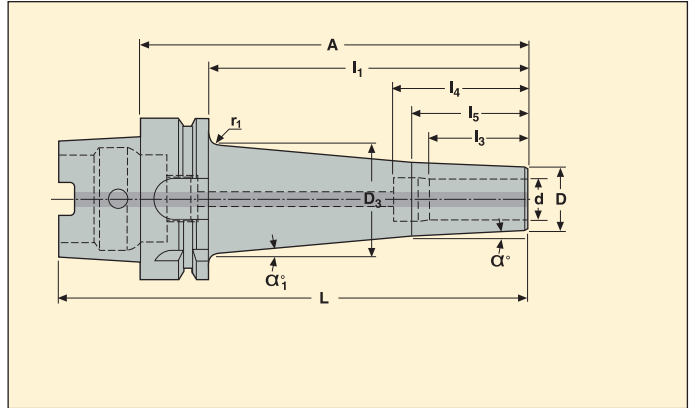

Taper	d mm	Part No.	Dimensions in mm								α°	α_1°	r_1	Balancing	
			A	D	D ₃	L	I ₁	I ₃	I ₄	I ₅					
HSK-A40	3	E930258010370	70	9	15,99	90	50	13	-	25	3	5	7	1	0,23
	3	E9302580103100	100	9	22,00	120	80	13	-	25	3	5	6	1	0,29
	4	E930258010470	70	10	16,99	90	50	15	-	25	3	5	7	1	0,24
	6	E930258010670	70	12	18,50	90	50	26	40	32	3	5	7	1	0,29
HSK-A63	3	E9304580103100	100	9	21,00	132	74	13	-	25	3	5	7	1	0,71
	3	E9304580103140	140	9	28,00	172	114	13	-	25	3	5	7	1	0,84
	4	E9304580104100	100	10	22,00	132	74	15	-	25	3	5	7	1	0,72
	4	E9304580104140	140	10	29,00	172	114	15	-	25	3	5	7	1	0,86
	5	E9304580105100	100	11	23,00	132	74	18	-	25	3	5	7	1	0,73
	5	E9304580105140	140	11	30,00	172	114	18	-	25	3	5	7	1	0,89
	6	E9304580106100	100	12	23,00	132	74	26	40	32	3	5	7	1	0,74
	6	E9304580106140	140	12	30,00	172	114	26	40	32	3	5	7	1	0,91
	8	E9304580108100	100	16	27,00	132	74	30	44	36	3	5	7	1	0,80
	8	E9304580108140	140	16	34,00	172	114	30	44	36	3	5	7	1	1,11
	10	E9304580110120	120	18	32,00	152	94	32	45	38	3	5	7	1	0,94
	10	E9304580110160	160	18	39,00	192	134	32	45	38	3	5	7	1	1,25
	12	E9304580112130	130	20	36,00	162	104	34	46	40	3	5	7	1	1,05
	12	E9304580112170	170	20	43,00	202	144	34	46	40	3	5	5	1	1,41
	14	E9304580114180	180	22	47,00	212	154	34	48	40	3	5	3	1	1,62
	16	E9304580116150	150	24	43,00	182	124	38	52	45	3	5	5	1	1,35
HSK-A100	6	E9306580106160	160	12	33,00	210	131	26	40	32	3	5	7	1	2,29
	8	E9306580108160	160	16	37,00	210	131	30	44	36	3	5	7	1	2,42
	10	E9306580110180	180	18	42,00	230	151	32	45	38	3	5	7	1	2,68
	12	E9306580112180	180	20	44,00	230	151	34	46	40	3	5	4,5	1	2,76
	14	E9306580114180	180	22	46,00	230	151	34	48	40	3	5	7	1	2,87
	16	E9306580116200	200	24	51,00	250	171	38	52	45	3	5	7	1	3,24

Please check availability in current price and stock-list

For Shrinkfit extensions, see page(s) 294

For HSK sealing plugs, coolant tubes and tube spanners, see page(s) 287



- Run-out 3 µm maximum at 3xd
- High transmittable torque
- High RPM suitable

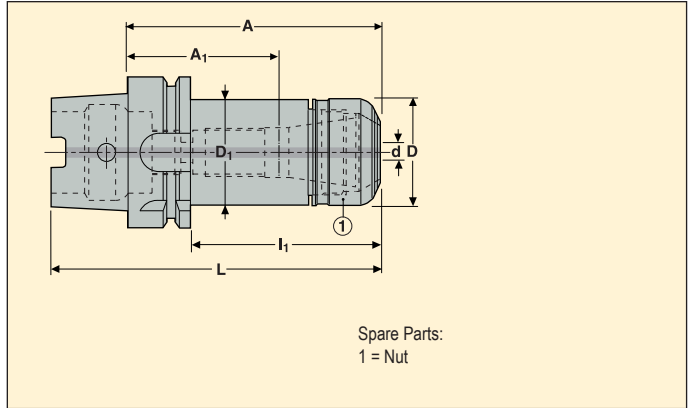

Taper	Capacity d mm	Part No.	Chuck & Collet Size	Dimensions in mm						A ₁ min-max*	**	Balancing	
				A	D	D ₁	L	I ₁					
HSK-A40	1-7	E930256721150	HP 11	50	16	16	70	30	20-32	**	1	0,3	
	1-10	E930256721660	HP 16	60	30	30	80	40	20-33	**	1	0,36	
HSK-A63	1-7	E9304567211100	HP 11	100	16	16	132	74	56-82		1	0,8	
	1-10	E930456721660	HP 16	60	30	30	92	34	28-33	**	1	0,77	
	1-10	E9304567216100	HP 16	100	30	30	132	74	56-73		1	0,96	
	1-10	E9304567216130	HP 16	130	30	30	162	104	86-103		1	1,11	
	1-10	E9304567216160	HP 16	160	30	30	192	134	116-133		1	1,26	
	2-16	E9304567225100	HP 25	100	40	40	132	74	49-66		1	1,16	
	2-16	E9304567225130	HP 25	130	40	40	162	104	66-96		1	1,42	
	2-16	E9304567225160	HP 25	160	40	40	192	134	96-126		1	1,69	
	2-20	E9304567232100	HP 32	100	50	50	132	74	52-60		1	1,42	
	2-20	E9304567232130	HP 32	130	50	50	162	104	67-90		1	1,84	
HSK-A100	2-16	E9306567225160	HP 25	160	40	40	210	131	96-126		1	2,99	
	2-20	E9306567232100	HP 32	100	50	50	150	71	55-60		1	2,74	
	2-20	E9306567232160	HP 32	160	50	50	210	131	97-120		1	3,55	

For ER HP collets type 5672, see page(s) 297-300

* A1 setting length onto stop screw when possible, or total available setting length for chucks without thread for stop end screw, ** Chuck without thread for stop screw

Accessories***

For size	Socket	Spanner	Stop screw	Torque key
HP 11	03EF567211	03B567211	19B5870812	03DYD010100
HP 16	03EF567216	03B567216	19B58711	03DYD010100
HP 25	03EF567225	03B567225	19B58718	03DYD020200
HP 32	03EF567232	03B567232	19B58722	03DYD020200

Spare Parts

For size	Nut
HP 11	08B567211
HP 16	08B567216
HP 25	08B567225
HP 32	08B567232

Please check availability in current price and stock-list

** When using a stop end screw, its tapered contact onto the tool shank can increase the tool run-out defect. For tightening torques, see Guide pages

EPB 5835 – Hydraulic chucks, strong

HSK-A/ ISO 12164-1-A



- Run-out 4 μm maximum at 3xd

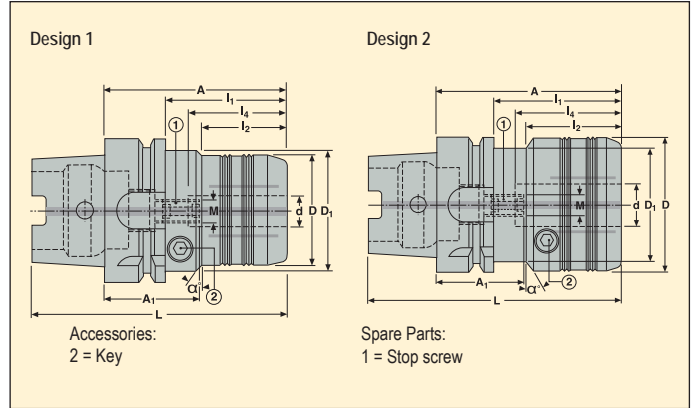

Taper	d mm	Part No.	Dimensions in mm							M mm	Design	α°	Balancing		
			A	D	D ₁	L	I ₁	I ₂	I ₄						A ₁ min-max
HSK-A63	12	E930458351280	80	48,0	52,5	112	54	38	47	33-43	M8	1	30	1	1,36
	20	E930458352085	85	62,5	52,5	117	59	43	52	33-43	M8	2	0	1	1,74
HSK-A100	20	E930658352095	95	62,5	-	145	66	-	52	43-53	M10	1	-	1	3,39
	32	E9306583532100	100	80,0	-	150	71	-	63	37-47	M10	1	-	1	4,30

For reduction sleeves and control gauges, see page(s) 295-296

Accessories

For taper	Locking key
HSK-A63	03HXL06
HSK-A100	03HXL06

Spare Parts

For taper	Stop screw
HSK-A63	19LS0816A
HSK-A100	19LS1016A

Please check availability in current price and stock-list
For HSK sealing plugs, coolant tubes and tube spanners, see page(s) 287



- Run-out 3 µm maximum at 3xd

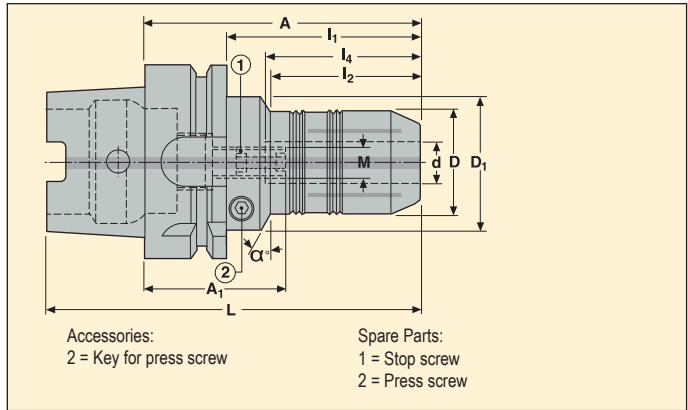

Taper	d mm	Part No.	Dimensions in mm								M mm	*	α°	Balancing	
			A	D	D ₁	L	I ₁	I ₂	I ₄	A ₁ min-max					
HSK-A63	6	E930458340670	70	26	50	102	44	23	38	32-42	M5	*	30	1	0,97
	8	E930458340870	70	28	50	102	44	24	38	32-42	M5	*	30	1	0,97
	10	E930458341080	80	30	50	112	54	34	42	38-48	M8	*	30	1	1,04
	12	E930458341285	85	32	50	117	59	40	47	38-48	M10	-	30	1	1,07
	14	E930458341485	85	34	50	117	59	40	47	38-48	M10	*	30	1	1,09
	16	E930458341690	90	38	50	122	64	46	50	40-50	M10	*	30	1	1,18
	18	E930458341890	90	40	50	122	64	48	50	40-50	M10	*	30	1	1,19
	20	E930458342090	90	42	50	122	64	47	52	38-48	M10	*	30	1	1,22
	25	E9304583425120	120	58	53	152	94	78	58	62-72	M10	*	60	1	2,19
32	E9304583432125	125	64	53	157	-	-	63	64-74	M10	*	90	1	2,46	
HSK-A100	12	E930658341295	95	32	50	145	66	40	47	48-58	M10	*	30	1	2,50
	16	E930658341695	95	38	50	145	66	46	50	45-55	M10	*	30	1	2,53
	20	E9306583420105	105	42	50	155	76	47	52	53-63	M10	*	30	1	2,83
	25	E9306583425110	110	58	70	160	81	50	58	52-62	M10	*	30	1	3,58
	32	E9306583432110	110	64	70	160	81	60	63	47-57	M10	*	30	1	3,60

For reduction sleeves, see page(s) 295 and control gauges, see page(s) 296

* Conform to DIN 69882-7.

Accessories

For d	Locking key
A63/6-8	H04-4
A63/10	H04-4
A63/12	H04-4
A63/14-20	H04-4
A63/25-32	H04-4
A100/12	H04-4
A100/16-32	H04-4

Spare Parts

For d	Press screw	Stop screw
A63/6-8	950AF0810008	19LS0512A
A63/10	950AF0810008	19LS0820T
A63/12	950AF0810008	19LS1016A
A63/14-20	950AF1010010	19LS1016A
A63/25-32	950AF1010010	19LS1020A
A100/12	950AF0810008	19LS1020A
A100/16-32	950AF1010010	19LS1020A

Please check availability in current price and stock-list

For HSK sealing plugs, coolant tubes and tube spanners, see page(s) 287



• Run-out 10 µm maximum at 3xd

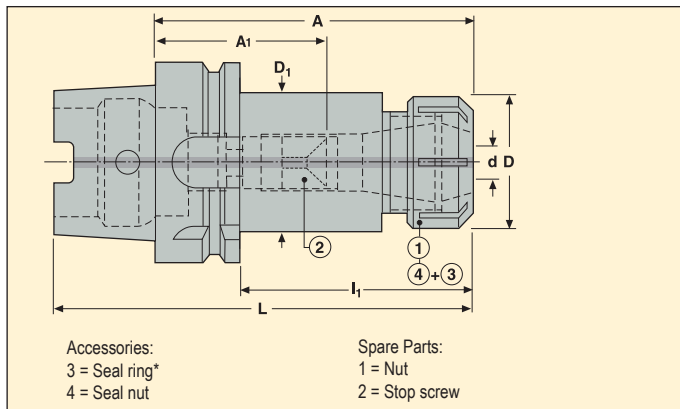

Taper	Capacity d mm	Part No.	Chuck & Collet Size	Dimensions in mm						A ₁ min-max	*	Balancing	
				A	D	D ₁	L	I ₁					
HSK-A32	0,5-10	E930156751660	ER 16	60	32	25	76	40	24-30		1	0,24	
HSK-A40	0,5-10	E930256751660	ER 16	60	32	32	80	40	26-30		1	0,35	
	1-16	E930256752570	ER 25	70	42	34	90	50	-		1	0,44	
HSK-A63	0,5-10	E9304567516100	ER 16	100	32	32	132	74	52-68		1	0,99	
	0,5-10	E9304567516160	ER 16	160	32	32	192	134	112-128	*	1	1,35	
	1-16	E9304567525100	ER 25	100	42	42	132	74	44-62	*	1	1,21	
	1-16	E9304567525160	ER 25	160	42	42	192	134	91-122		1	1,82	
	2-20	E9304567532100	ER 32	100	50	50	132	74	45-60	*	1	1,4	
	2-20	E9304567532160	ER 32	160	50	50	192	134	92-120		1	2,28	
	3-26	E9304567540120	ER 40	120	63	53	152	94	53-75	*	1	1,81	
HSK-A100	1-16	E9306567525100	ER 25	100	42	42	150	71	52-62		1	2,54	
	1-16	E9306567525160	ER 25	160	42	42	210	131	91-122		1	3,14	
	2-20	E9306567532100	ER 32	100	50	50	150	71	53-60	*	1	2,73	
	2-20	E9306567532160	ER 32	160	50	50	210	131	92-120		1	3,57	
	3-26	E9306567540120	ER 40	120	63	63	170	91	58-75	*	1	3,56	

For ER collets, see page(s) 302-303, ER extensions, see page(s) 301

* Conform to DIN 69882-6

Accessories*

For size	Seal nut	Spanner
ER 16	08B587516IC	03B587516
ER 25	08B587525IC	03B587525
ER 32	08B587532IC	03B587532
ER 40	08B587540IC	03B587540

Spare Parts

For size	Nut	Stop screw
ER 16	08B587516X	19B58711
ER 25	08B587525X	19B58718
ER 32	08B587532X	19B58722
ER 40	08B587540X	19B58730

Please check availability in current price and stock-list

* For ER sealing rings, see page(s) 304

For HSK sealing plugs, coolant tubes and tube spanners, see page(s) 287



- Run-out 40 µm maximum at 2,5xd

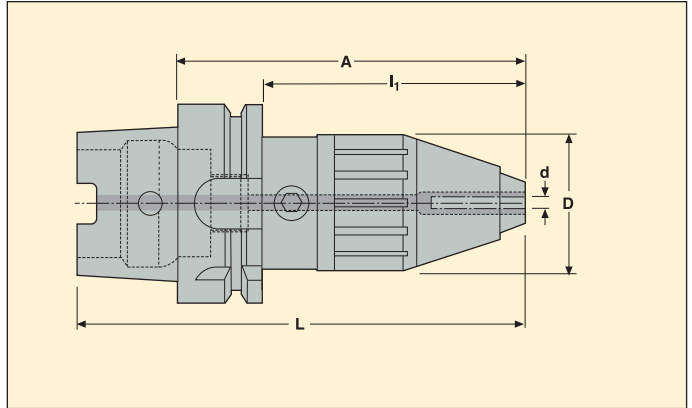

Taper	Capacity d mm	Part No.	Dimensions in mm				Balancing	
			A	D	L	I ₁		
HSK-A63	1-13	E9304508513	110	43	142	84	2	1,17
	2,5-16	E9306508516	134	56	184	105	2	3,26
HSK-A100								

Accessories

For Capacity d	Key
1-13	H06-4
2,5-16	H06-4

Please check availability in current price and stock-list
 For HSK sealing plugs, coolant tubes and tube spanners, see page(s) 287

EPB 5867 – Tapping chucks for synchronized tapping, with micro-compensation



- Inbuilt axial micro flexure (+/- 0,5 mm) prevents from tapping tap stress
- Tap fitting based on ER tapping collets with square drive
- Maximum coolant pressure 80 bar

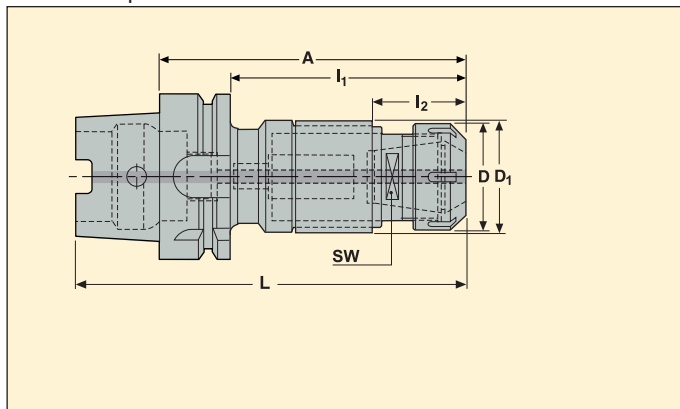

Taper	Tapping range	Part No.	Size	Dimensions in mm							Balancing	
				A	D	D ₁	L	I ₁	I ₂	SW		
HSK-A63	M4-M12	E9304586720108	ER 20	108,1	33,7	35	140	82,2	40,3	22,00	-	1,10
	M8-M20	E9304586725128	ER 25	127,5	42	44	159,4	101,5	42,1	28,00	-	1,50
	M16-M30	E9304586740160	ER 40	159,9	62,7	62	191,8	133,9	52	39,60	-	2,90
HSK-A100	M4-M12	E9306586720115	ER 20	114,6	33,7	35	164,5	85,7	40,3	22,00	-	4,20
	M8-M20	E9306586725134	ER 25	134	42	44	183,9	105	42,1	28,00	-	2,50
	M16-M30	E9306586740163	ER 40	163,4	62,7	62	213,3	134,4	52	39,60	-	2,90

For ER tapping collets with square drive, see page(s) 308

Accessories

For size	Locking key	Spanner
ER 20	5680092-04	03B587520UM
ER 25	5680092-05	03B587525
ER 40	5680092-06	03B587540

Spare Parts

For size	Nut
ER 20	5533051-02
ER 25	5533051-03
ER 40	5533051-05

Please check availability in current price and stock-list

For EPB 5867 sealing rings, see page(s) 309

For HSK sealing plugs, coolant tubes and tube spanners, see page(s) 287

EPB 5283 – Quick change tapping chucks with axial compensation

HSK-A/ ISO 12164-1-A



- With extension and compression
- Maximum coolant through pressure 15 bar

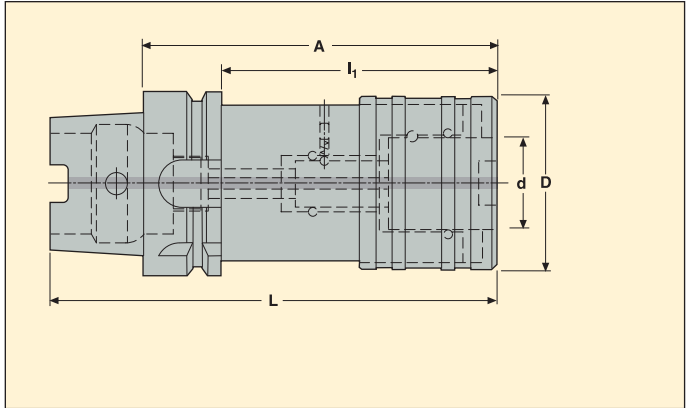

Taper	Tapping range	Part No.	For tap adapter		Dimensions in mm						
			Size	d mm	Compression	Extension	A	D	L	I ₁	
HSK-A63	M3-M12	ET930452832L	2	19	7,5	7,5	120	39	152	94	1,25
	M8-M20	ET930452833L	3	31	12,5	12,5	155	59	187	129	2,51
HSK-A100	M3-M12	ET930652832L	2	19	7,5	7,5	125	39	175	96	2,6
	M8-M20	ET930652833L	3	31	12,5	12,5	165	59	215	136	3,92

Please check availability in current price and stock-list
 For quick change tap adapters, see page(s) 311-312
 For HSK sealing plugs, coolant tubes and tube spanners, see page(s) 287

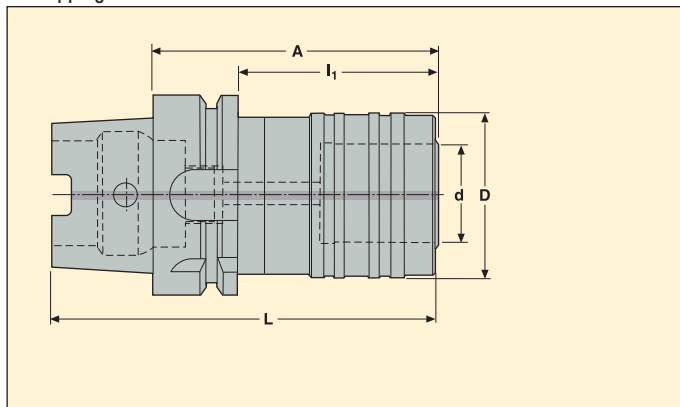

- No compensation
- Maximum coolant through pressure 50 bar

Taper	Tapping range	Part No.	For tap adapter		Dimensions in mm				Balancing	KG
			Size	d mm	A	D	L	I ₁		
HSK-A63	M3-M12	ET930452602	2	19	90	32	122	64	2	0,96
	M8-M20	ET930452603	3	31	115	52	147	89	2	1,74
HSK-A100	M3-M12	ET930652602	2	19	95	32	145	66	2	2,29
	M8-M20	ET930652603	3	31	120	52	170	91	2	3,15
	M14-M33	ET930652604	4	48	155	73	205	126	2	4,66

Please check availability in current price and stock-list
 For quick change tap adapters, see page(s) 311-312
 For HSK sealing plugs, coolant tubes and tube spanners, see page(s) 287



- Direct run-out 5 µm maximum
- No compensation

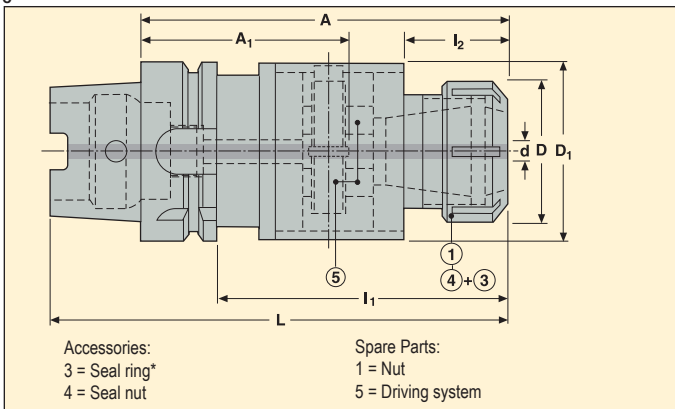

Taper	Tapping range	Part No.	For tap adapter		Dimensions in mm							Balancing	
			Size	d mm	A	D	D ₁	L	I ₁	I ₂	A ₁		
HSK-A63	M5-M30	E9304586532130	ER 32	2-20	130	50	63	162	–	37	73,5	2	2,12
	M12-M33	E9306586540115	ER 40	3-26	115	63	63	165	86	–	52,5	2	3,2

For ER collets, see page(s) 302-303

Accessories*

For size	Key	Seal nut
ER 32		
ER 40		

Spare Parts

For size	Driving system	Nut
ER 32		
ER 40		

Please check availability in current price and stock-list
 * For ER type sealing rings, see page(s) 304
 For HSK sealing plugs, coolant tubes and tube spanners, see page(s) 287

EPB 5023 – Greenstock blanks

HSK-A/ISO 12164-1-A

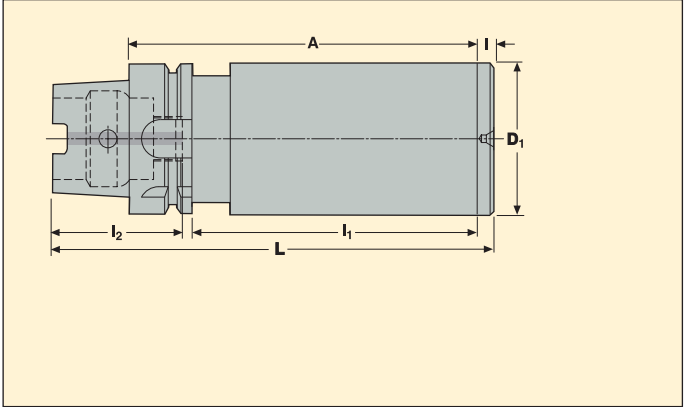

Taper	Part No.	Dimensions in mm						Balancing	
		A	D ₁	L	I	I ₁	I ₂		
HSK-A40	E9302502340150	150	40	178	8	130	36	2	1,51
HSK-A63	E9304502363250	250	63	290	8	224	54	2	6,18
HSK-A100	E9306502363250	250	63	308	8	221	78.5	2	7,56
	E9306502395250	250	95	308	8	221	78.5	2	14,00

Please check availability in current price and stock-list
 For HSK sealing plugs, coolant tubes and tube spanners, see page(s) 287

EPB 5603 – Shrinkfit holders, DIN type

HSK-E (with thread for coolant tube*)



- Run-out 3 μm at 3xd (direct run-out 3 μm) maximum
- Delivered with one stop screw

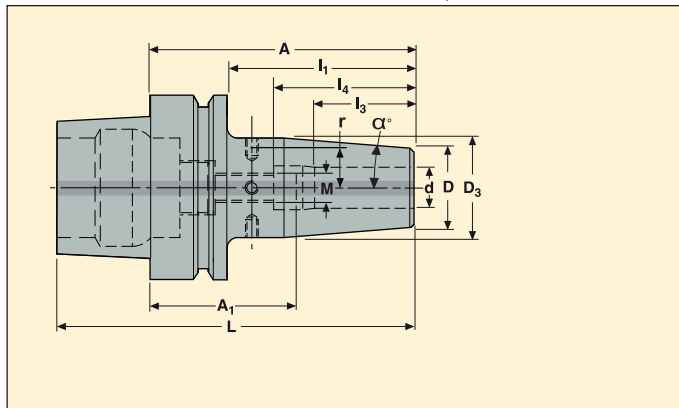

Taper	d mm	Part No.	Dimensions in mm								M mm	α°	r mm	**	Balancing		
			A	D	D ₃	L	I ₁	I ₃	I ₄	A ₁ min-max							
HSK-E32	3	E934156030345	45	15	–	61	25	13	–	–	–	4,5	–	**	1	0,16	
	4	E934156030445	45	15	–	61	25	15	–	–	–	4,5	–	**	1	0,20	
	6	E934156030650	50	21	–	66	30	26	33	–	–	4,5	–	**	1	0,22	
	8	E934156030850	50	21	–	66	30	26	33	–	–	4,5	–	**	1	0,30	

Please check availability in current price and stock-list *For HSK sealing plugs, coolant tubes and tube spanners, see page(s) 287
 ** Extra-short holder, without thread for a stop screw nor threaded holes for balancing screws and requiring a dedicated Easyshrink® cooling contact bush type '5603 extra-short', see page(s) 337. For Shrinkfit extensions, see page(s) 294

EPB 5603 – Shrinkfit holders, DIN type



- Run-out 3 μm at 3xd (direct run-out 3 μm) maximum
- Delivered with one stop screw

HSK-E (with thread for coolant tube*)

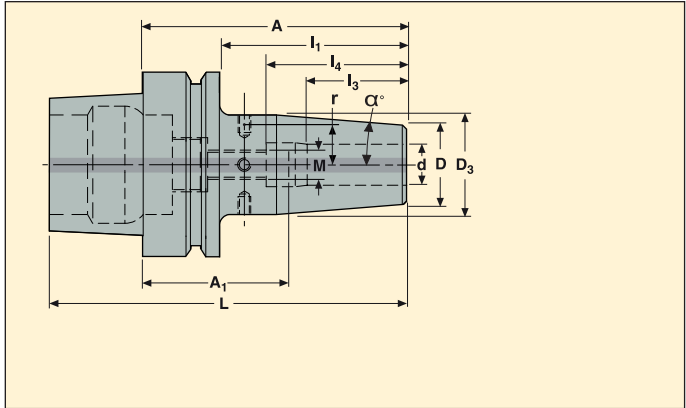

Taper	d mm	Part No.	Dimensions in mm								M mm	α°	r mm	**	Balancing	KG
			A	D	D ₃	L	I ₁	I ₃	I ₄	A ₁ min-max						
HSK-E40	3	E934256030350	50	15	–	70	30	13	–	–	–	4,5	–	**	1	0,30
	4	E934256030450	50	15	–	70	30	15	–	–	–	4,5	–	**	1	0,30
	6	E934256030650	50	21	–	70	30	22	31	–	–	4,5	–	**	1	0,30
	6	E934256030670	70	21	27	90	50	22	37,5	34-44	M5	4,5	10,5	–	1	0,40
	8	E934256030850	50	21	–	70	30	26	31	–	–	4,5	–	**	1	0,30
	8	E934256030870	70	21	27	90	50	26	37,5	34-44	M6	4,5	10,5	–	1	0,36
	10	E934256031055	55	24	–	75	35	31	36	–	–	4,5	–	**	1	0,40
	12	E934256031260	60	24	–	80	40	34	41	–	–	4,5	–	**	1	0,40
	16	E934256031665	65	27	–	85	45	39	46	–	–	4,5	–	**	1	0,40

* Extra-short holder, without thread for a stop screw nor threaded holes for balancing screws and requiring a dedicated Easyshrink® cooling contact bush type '5603 extra-short', see page(s) 337. For Shrinkfit extensions, see page(s) 294

Accessories

For d	Balancing screws
6	90ZQ01
8	90ZQ01

Spare Parts

For d	Stop screw
6	19BDR05165
8	19BDR06165

Please check availability in current price and stock-list

* For HSK sealing plugs, coolant tubes and tube spanners, see page(s) 287

For stop screw setting adapters, see page(s) 336

EPB 5603 – Shrinkfit holders, DIN type



- Run-out $3 \mu\text{m}$ at $3xd$ (direct run-out $3 \mu\text{m}$) maximum
- Delivered with one stop screw

HSK-E (with thread for coolant tube*)

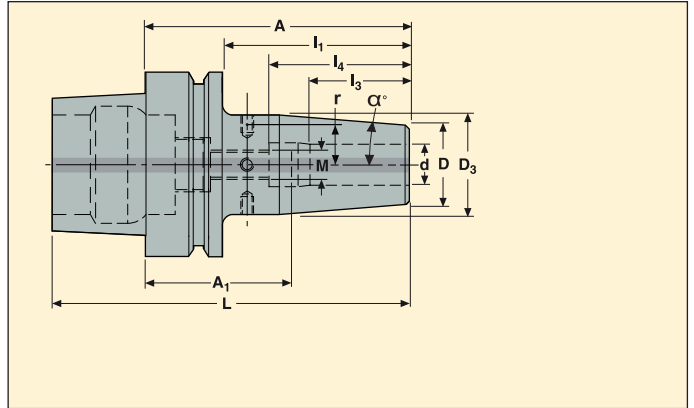

Taper	d mm	Part No.	Dimensions in mm								M mm	α°	r mm	**	Balancing	KG
			A	D	D ₃	L	I ₁	I ₃	I ₄	A ₁ min-max						
HSK-E50	3	E934356030355	55	15	-	80	29	13	-	-	-	4,5	-	**	1	0,50
	4	E934356030455	55	15	-	80	29	15	-	-	-	4,5	-	**	1	0,45
	6	E934356030655	55	21	-	80	29	22	32	-	-	4,5	-	**	1	0,50
	8	E934356030855	55	21	-	80	29	26	32	-	-	4,5	-	**	1	0,50
	10	E934356031060	60	24	-	85	34	31	37	-	-	4,5	-	**	1	0,60
	12	E934356031265	65	24	-	90	39	34	42	-	-	4,5	-	**	1	0,60
	12	E934356031290	90	24	32	115	64	34	47,5	44-54	M10x1	4,5	13,0		1	0,70
	16	E934356031670	70	27	-	95	44	39	47	-	-	4,5	-	**	1	0,60

** Extra-short holder, without thread for a stop screw nor threaded holes for balancing screws and requiring a dedicated Easyshrink® cooling contact bush type '5603 extra-short', see page(s) 337. For Shrinkfit extensions, see page(s) 294

Accessories

For	Balancing screws
E934356031290	90ZQ01

Spare Parts

For	Stop screw
E934356031290	19BDR10165

Please check availability in current price and stock-list
 * For HSK sealing plugs, coolant tubes and tube spanners, see page(s) 287
 For stop screw setting adapters, see page(s) 336

EPB 5801 – Shrinkfit holders, Mould and Die type

HSK-E (with thread for coolant tube*)



• Run-out 3 µm at 3xd (direct run-out 3 µm) maximum

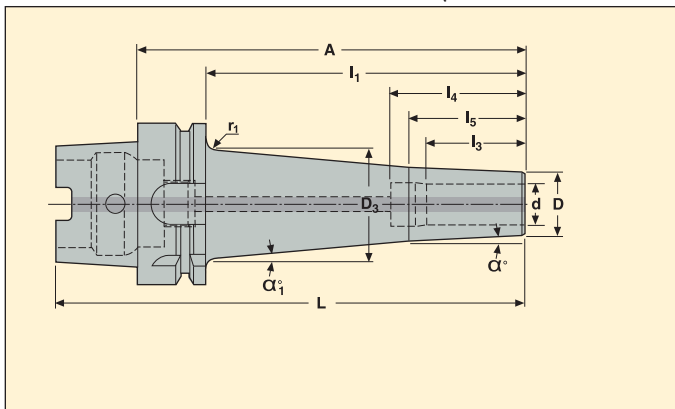

Taper	d mm	Part No.	Dimensions in mm								r_1	α°	α_1°	Balancing	
			A	D	D_3	L	I_1	I_3	I_4	I_5					
HSK-E40	3	E934258010360	60	9	13,14	80	40	13	-	-	7	3	-	1	0,23
	3	E9342580103100	100	9	21,50	120	80	13	-	25	6	3	5	1	0,30
	4	E934258010460	60	10	14,20	80	40	15	-	-	7	3	-	1	0,24
	4	E9342580104100	100	10	22,50	120	80	15	-	25	7	3	5	1	0,32
	6	E934258010660	60	12	16,20	80	40	26	40	-	7	3	-	1	0,25
	6	E9342580106100	100	12	24,00	120	80	26	40	32	6	3	5	1	0,34
	8	E934258010860	60	16	20,14	80	40	30	42	-	7	3	-	1	0,27
	10	E934258011060	60	18	22,20	80	40	32	42	-	-	3	-	1	0,28
HSK-E50	3	E9343580103100	100	9	20,20	125	74	13	-	25	7	3	5	1	0,50
	4	E9343580104100	100	10	21,20	125	74	15	-	25	7	3	5	1	0,51
	6	E9343580106100	100	12	22,70	125	74	26	40	32	7	3	5	1	0,53
	8	E9343580108100	100	16	26,50	125	74	30	44	36	7	3	5	1	0,59

Please check availability in current price and stock-list
 * For HSK sealing plugs, coolant tubes and tube spanners, see page(s) 287
 For Shrinkfit extensions, see page(s) 294

EPB 5672 – High precision collet chucks



- Run-out 3 μm maximum at 3xd
- High transmittable torque
- High RPM suitable

HSK-E (with thread for coolant tube****)

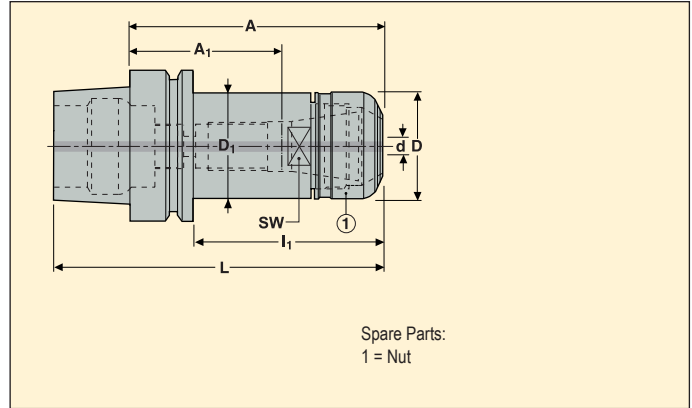

Taper	Capacity d mm	Part No.	Chuck & Collet Size	Dimensions in mm							SW***	**	Balancing	
				A	D	D ₁	L	I ₁	A ₁ min-max*					
HSK-E25	1-7	E934056721150	HP 11	50	16	16	63	40	15-32	13	**	1	0,1	
	1-10	E934056721655R	HP 16R	55	24	24	68	45	21-28	21	**	1	0,14	
HSK-E32	1-7	E934156721150	HP 11	50	16	16	66	30	18-32	13	**	1	0,2	
	1-10	E934156721660R	HP 16R	60	24	24	76	40	25-33	21	**	1	0,24	
HSK-E40	1-7	E934256721150	HP 11	50	16	16	70	30	20-32	13	**	1	0,3	
	1-10	E934256721660	HP 16	60	30	30	80	40	29-33	27	**	1	0,36	
	1-10	E9342567216120	HP 16	120	30	30	140	100	68-93	27	**	1	0,67	
	2-16	E934256722570	HP 25	70	40	40	90	–	21-36	36	**	1	0,47	
HSK-E50	1-10	E934356721660	HP 16	60	30	30	85	34	24-33	27	**	1	0,54	
	1-10	E9343567216120	HP 16	120	30	30	145	94	75-93	27	**	1	0,83	
	2-16	E934356722570	HP 25	70	40	40	95	44	25-36	36	**	1	0,67	

For ER HP collets type 5672, see page(s) 297-300, Chuck size HP 16R use the collet size ER HP 16. * A₁ when using a stop end screw.
 ** Chuck without thread for stop end screw. *** Flats for preventing the chuck from rotation during collet nut tightening, as HSK-E tapers are without driving slots.

Accessories****

For size	Socket	Spanner	Stop screw	Torque key
HP 11	03EF567211	03B567211	19B5870812	03DYD010100
HP 16	03EF567216	03B567216	19B58711	03DYD010100
HP 16R	03EF567216R	03B567216R	19B58711	03DYD010100
HP 25	03EF567225	03B567225	19B58718	03DYD020200

Spare Parts

For size	Nut
HP 11	08B567211
HP 16	08B567216
HP 16R	08B567216R
HP 25	08B567225

Please check availability in current price and stock-list

**** When using a stop end screw, its tapered contact onto the tool shank can increase the tool run-out defect. For tightening torques, see Guide pages

***** For HSK sealing plugs, coolant tubes and tube spanners, see page(s) 287

EPB 5834 – Hydraulic chucks

HSK-E (with thread for coolant tube*)



- Run-out $3 \mu\text{m}$ maximum at $3x d$

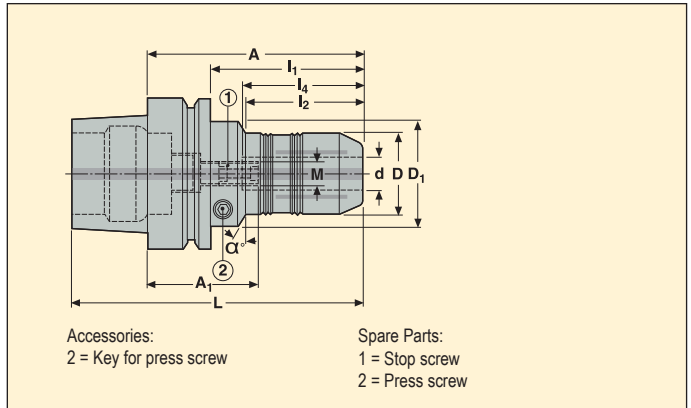

Taper	d mm	Part No.	Dimensions in mm								M mm	α°	Balancing	
			A	D	D ₁	L	I ₁	I ₂	I ₄	A ₁ min-max				
HSK-E50	12	E934358341285	85	32,0	42	110	59	40	47	33-48	M8	30	1	0,78

For reduction sleeves, see page(s) 295 and control gauges, see page(s) 296

Accessories

For Taper/d	Locking key
HSK-E50/12	H04-4

Spare Parts

For Taper/d	Press screw	Stop screw
HSK-E50/12	950AF1010010	19LS0816A

Please check availability in current price and stock-list
* For HSK sealing plugs, coolant tubes and tube spanners, see page(s) 287

EPB 5675 – ER collet chucks – ISO 15488

HSK-E (with thread for coolant tube*)



- Run-out 10 µm maximum at 3xd

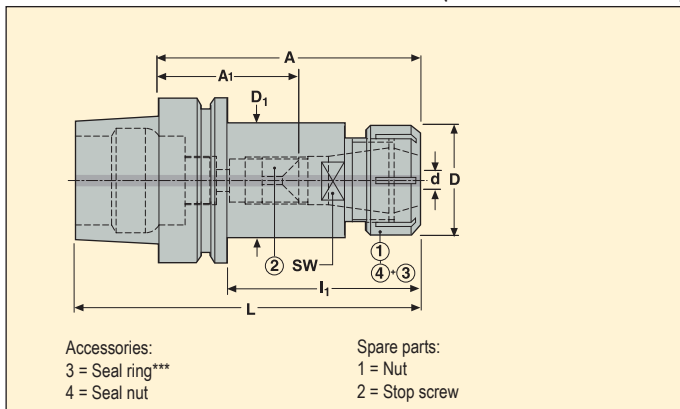

Taper	Capacity d mm	Part No.	Chuck & Collet Size	Dimensions in mm								Balancing	
				A	D	D ₁	L	I ₁	A ₁ min-max	SW**			
HSK-E32	0,5-10	E934156751660	ER 16	60	32	25	76	40	24-30	22	1	0,25	
HSK-E40	0,5-10	E934256751660	ER 16	60	32	32	80	40	26-30	27	1	0,36	
	1-16	E934256752570	ER 25	70	42	34	90	50	-	30	1	0,45	
HSK-E50	0,5-10	E9343567516100	ER 16	100	32	32	125	74	53-68	21	1	0,76	
	1-16	E9343567525100	ER 25	100	42	42	125	74	44-62	38	1	0,97	
	1-16	E9343567532100	ER 32	100	50	42	125	74	45-60	38	1	0,98	

For ER collets, see page(s) 302-303

ER extensions, see page(s) 301

** Flats for preventing the chuck from rotation during collet nut tightening, as HSK-E tapers are without driving slots.

Accessories***

For size	Seal nut	Spanner
ER 16	08B587516IC	03B587516
ER 25	08B587525IC	03B587525
ER 32	08B587532IC	03B587532

Spare Parts

For size	Nut	Stop screw
ER 16	08B587516X	19B58711
ER 25	08B587525X	19B58718
ER 32	08B587532X	19B58722

Please check availability in current price and stock-list

* For HSK sealing plugs, coolant tubes and tube spanners, see page(s) 287

*** For ER sealing rings, see page(s) 304



- With expandable hydraulic spigot
- Direct run-out 5 µm maximum
- With coolant supply channels through the spigot

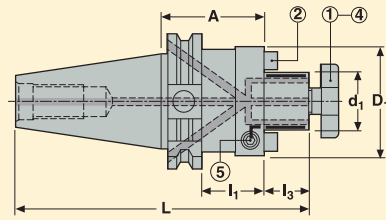

Accessories:
4 = Bolt
5 = Key

Spare Parts:
1 = Bolt
2 = Tenon

Taper	d ₁ mm	Part No.	Dimensions in mm					*	Balancing	KG
			A	D ₁	L	I ₁	I ₃			
DIN40 ADB	22	E346955452235	35	48	122,4	16	19		1	1,04
	27	E346955452745	45	60	134,4	26	21	*	1	1,30
DIN50 ADB/ CAT50	22	E347855452235	35	48	155,7	16	19		1	3,30
	27	E347855452740	40	60	162,7	21	21		1	3,50
	32	E347855453250	50	78	175,7	31	24		1	3,60
	40	E347855454050	50	89	178,7	31	27		1	3,88

* Length A (45) on type Accu-Fit™ 5545 is longer than on classic type 5525 (35), available on next page

Accessories

For d ₁	Bolt, through coolant	Key	Spanner
22	5802210L	H04-4	5812210
27	5802712L	H04-4	5812712
32	5803216L	H04-4	5813216
40	5804020L	H04-4	5814020

Spare Parts

For d ₁	Bolt	Screw	Tenon
22	5802210	951D0416	16C2101111
27	5802712	951D0508	16C2121214
32	5803216	951D0516	16C2141421
40	5804020	951D0516	16C2161621

Please check availability in current price and stock-list



- With dynamic damping, ready to use
- Direct run-out 5 μm maximum
- With coolant supply channels through the spigot

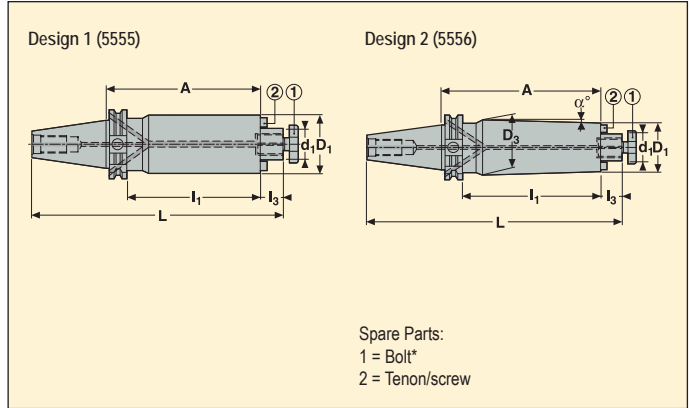

Taper	d ₁ mm	Part No.	Dimensions in mm						Design	α°	Balancing	KG
			A	D ₁	D ₃	L	I ₁	I ₃				
DIN40 ADB	16	E3469555516160	160	38	–	245,4	141	17	1	–	2	2,12
	22	E3469555522210	210	48	–	297,4	191	19	1	–	2	3,74
	22	E3469555622260	260	48	63,2	347,4	241	19	2	1,9	2	5,56
DIN50 ADB	22	E3471555522210	210	48	–	330,7	191	19	1	–	2	5,36
	22	E3471555622260	260	48	66,0	380,7	241	19	2	2,0	2	7,52
	27	E3471555527260	260	60	–	382,7	241	21	1	–	2	8,52
	27	E3471555627320	320	60	79,5	442,7	301	21	2	1,7	2	12,26
	32	E3471555532330	330	78	–	455,7	311	24	1	–	2	14,96
	40	E3471555540350	350	89	–	475,7	331	27	1	–	2	20,40

d₁ 40, includes 4 threaded holes on the bearing face according to DIN 6357

Accessories

For d ₁	Spanner
16	5811608
22	5812210
27	5812712
32	5813216
40	5814020

Spare Parts*

For d ₁	Bolt	Screw	Tenon
16	5801608	950D0312	16C2080810A
22	5802210	950D0416	16C2101111
27	5802712	950D0516	16C2121214A
32	5803216	950D0516	16C2141421A
40	5804020	950D0616	16C2161621A

Please check availability in current price and stock-list

* These centre bolts are similar to the original delivered ones: check if lengths L are suitable for the milling cutters used, therefore see instructions in catalogue's Guide pages or in the Operating instructions sheet delivered with the holders



- Direct run-out 5 µm maximum
- With coolant supply channels through the spigot

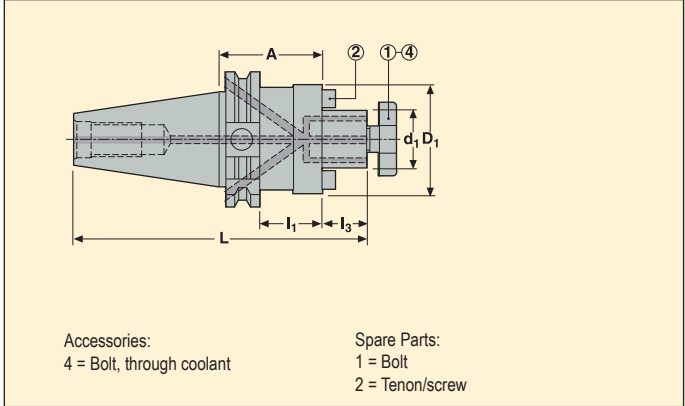

Taper	d ₁ mm	Part No.	Dimensions in mm					*	Balancing	
			A	D ₁	L	I ₁	I ₃			
DIN40 ADB	16	E346955251635	35	38	120,4	16	17		2	0,94
	16	E3469552516100	100	38	185,4	81	17		2	1,46
	22	E346955252235	35	48	122,4	16	19		2	1,05
	22	E3469552522100	100	48	187,4	81	19		2	1,90
	27	E346955252745	45	60	134,4	26	21	*	2	1,30
	27	E3469552527100	100	60	189,4	81	21		2	3,55
	32	E346955253250	50	78	142,4	–	24		2	1,74
	40	E346955254050	50	89	145,4	–	27		2	1,98
	27	E346955242735	35	48	124,4	16	21	*	2	1,10

d₁ 40, includes 4 threaded holes on the bearing face according to DIN 6357

* Diameter D₁ on type 5524 is smaller than on type 5525

Accessories

For d ₁	Bolt, through coolant	Spanner
16	5801608L	5811608
22	5802210L	5812210
27/5524	5802712L	5812712
27100/5525	5802712L	5812712
2745/5525	5802712L	5812712
32	5803216L	5813216
40	5804020L	5814020

Spare Parts

For d ₁	Bolt	Screw	Tenon
16	5801608	950D0312	16C10810164
22	5802210	951D0416	16C11012206
27/5524	5802712	951D0512	16C127
27100/5525	5802712	951D0516	16C11214243
2745/5525	5802712	951D0512	16C127
32	5803216	951D0516	16C2141421
40	5804020	951D0616	16C2161621

Please check availability in current price and stock-list



- Direct run-out 5 µm maximum
- With coolant supply channels through the spigot

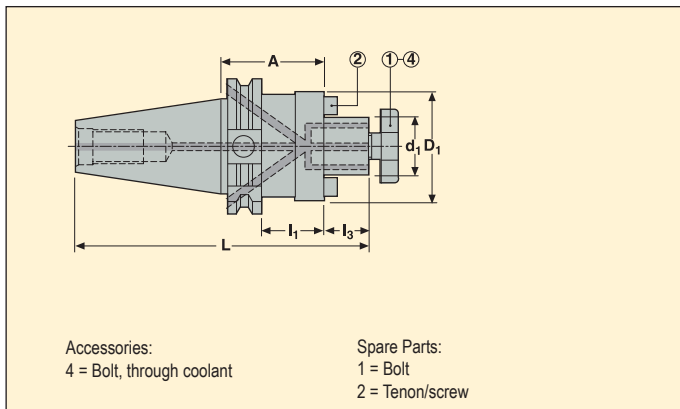

Taper	d ₁ mm	Part No.	Dimensions in mm					Balancing	 KG
			A	D ₁	L	I ₁	I ₃		
DIN50 ADB	16	E3471552516100	100	38	218,7	81	17	2	3,80
	22	E347155252235	35	48	155,7	16	19	2	3,00
	22	E3471552522100	100	48	220,7	81	19	2	4,75
	22	E3471552522160	160	48	280,7	141	19	2	5,15
	27	E347155252740	40	60	162,7	21	21	2	3,20
	27	E3471552527100	100	60	222,7	81	21	2	5,10
	27	E3471552527160	160	60	282,7	141	21	2	6,10
	32	E347155253250	50	78	175,7	31	24	2	4,00
	32	E3471552532100	100	78	225,7	81	24	2	6,40
	32	E3471552532160	160	78	285,7	141	24	2	8,40
	40	E347155254050	50	89	178,7	31	27	2	4,10
	40	E3471552540100	100	89	228,7	81	27	2	6,60
	40	E3471552540160	160	89	288,7	141	27	2	8,70

d₁ 40, includes 4 threaded holes on the bearing face according to DIN 6357

Accessories

For d ₁	Bolt, through coolant	Spanner
16	5801608L	5811608
22	5802210L	5812210
27	5802712L	5812712
32	5803216L	5813216
40	5804020L	5814020

Spare Parts

For d ₁	Bolt	Screw	Tenon
16	5801608	950D0312	16C10810164
22	5802210	950D0416	16C11012206
27	5802712	951D0512	16C11214243
32	5803216	951D0516	16C2141421
40	5804020	951D0616	16C2161621

Please check availability in current price and stock-list



- Direct run-out 5 µm maximum
- Small front face diameter D_1 according to ISO 3937, suitable for Seco disc mill cutters Type B

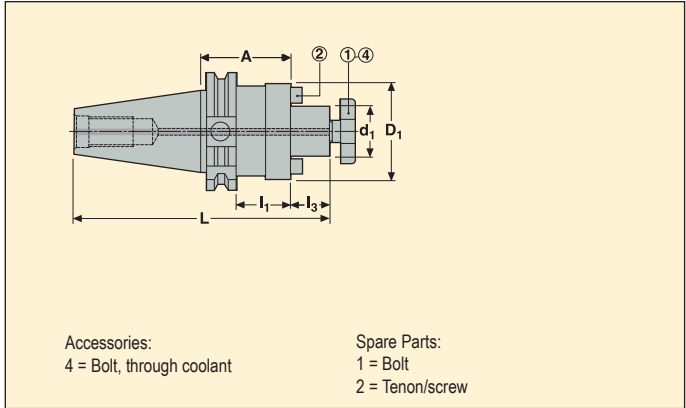

Taper	d_1 mm	Part No.	Dimensions in mm					Balancing	
			A	D_1	L	I_1	I_3		
DIN40 AD	16	E44695521644	44	32	129,4	25	17	2	0,95
	22	E44695522244	44	40	131,4	25	19	2	1,09
	27	E44695522744	44	48	133,4	25	21	2	1,24
	32	E44695523260	60	58	152,4	41	24	2	1,72
DIN50 AD	22	E44715522244	44	40	164,7	25	19	2	2,99
	27	E44715522744	44	48	166,7	25	21	2	3,02
	32	E44715523244	44	58	169,7	25	24	2	3,24
	40	E44715524044	44	70	172,7	25	27	2	3,60

Accessories

For d_1	Bolt, through coolant	Spanner
16	5801608L	5811608
22	5802210L	5812210
27	5802712L	5812712
32	5803216L	5813216
40	5804020L	5814020

Spare Parts

For d_1	Bolt	Screw	Tenon
16	5801608	950D0308	16C116
22	5802210	951D0410	16C122
27	5802712	951D0512	16C127
32	5803216	951D0514	16C132
40	5804020	951D0616	16C140

Please check availability in current price and stock-list

Monobloc holders DIN 69871

EPB 569 – Milling cutter holders, flange mounting – DIN 6357/ DIN 2079

DIN 69871-AD



- Direct run-out 5 µm maximum

Technical drawings showing:

- A circular view of the holder's flange with dimensions f and M .
- A side view of the holder with dimensions A , l_3 , d_1 , D_1 , and L .

 A circled '2' is shown next to the dimension l_3 .

Spare Parts:
2 = Tenon/Screw

Taper	d_1 mm	Part No.	Dimensions in mm					M mm	Balancing	KG
			A	D_1	L	l_3	f			
DIN50 A	40	E44715694070	70	89	201,7	30	66,7	M12	2	5,15
	60	E44715696070	70	129	211,7	40	101,6	M16	2	7,48

Spare Parts

For d_1	Screw	Tenon
40	951D0616	16C34040
60	951D1225	16C35060

Please check availability in current price and stock-list

EPB 5657 – Disc mill holders



- With adjustable slide rod
- Best suitable for Seco disc mill cutters Type A

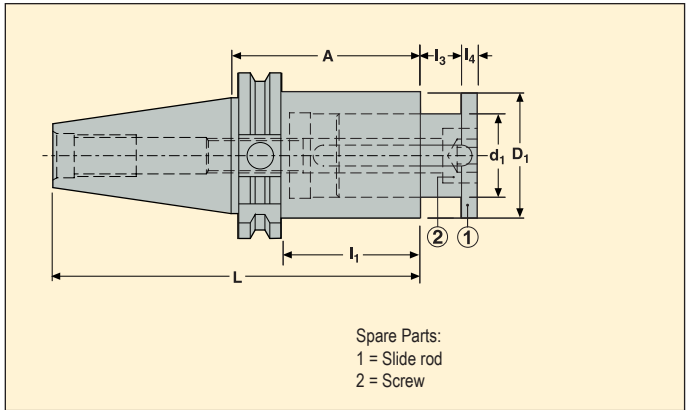

Taper	d ₁ mm	Part No.	Dimensions in mm						Balancing	KG
			A	D ₁	L	I ₁	I ₃	I ₄		
DIN40 A	22	E446956572265	65	35	133,4	45,9	0-12	4	2	1,16
	27	E446956572765	65	42	133,4	45,9	0-15	5	2	1,33
	32	E446956573290	90	48	158,4	70,9	0-24	6	2	1,85
DIN50 A	40	E4471565740100	100	58	201,7	80,9	0-30	7	2	4,38
	50	E4471565750160	160	72	261,7	140,9	0-32	8	2	7,06
	60	E4471565760180	180	90	281,7	160,9	0-40	8	2	10,44

Spare Parts

For d ₁	Screw	Slide rod
22	19C565722	565722
27	19C565727	565727
32	950D1690	565732
40	19C565740	565740
50	19C565750	565750
60	19C565760	565760

Please check availability in current price and stock-list

Monobloc holders DIN 69871

EPB 584 – Side lock holders, Weldon – DIN 1835 Form B/ DIN 6535 Form HB

DIN 69871-ADB



- Direct run-out 3 µm maximum
- Weldon d 16, 20, 25, 32 and 40 with ground face (Seco-Weldon compatible)

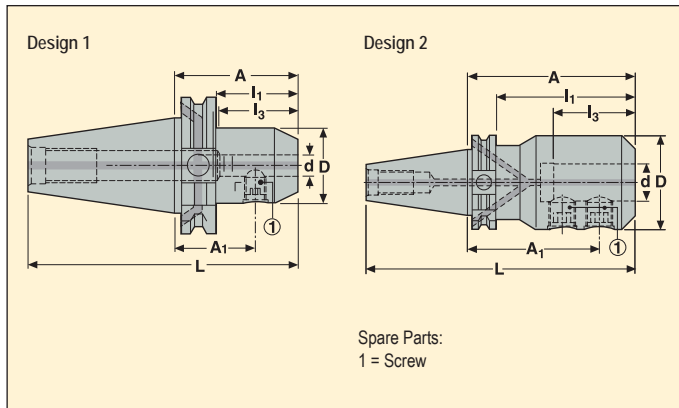

Taper	d mm	Part No.	Dimensions in mm						Design	Balancing	
			A	D	L	I ₁	I ₃	A ₁			
DIN40 ADB	6	E34695840650	50	25	118,4	31	27	32,5	1	2	0,88
	6	E346958406120	120	25	188,4	101	27	102,5	1	2	1,13
	8	E34695840850	50	28	118,4	31	30	32,5	1	2	0,93
	10	E34695841050	50	35	118,4	31	36	30,5	1	2	0,99
	12	E34695841250	50	42	118,4	31	43	28,0	1	2	1,04
	14	E34695841450	50	44	118,4	31	43	28,0	1	2	1,05
	16	E34695841663	63	48	131,4	44	46	39,5	1	2	1,28
	16	E346958416120	120	48	188,4	101	46	96,5	1	2	2,05
	18	E34695841863	63	50	131,4	44	46	39,5	1	2	1,30
	20	E34695842063	63	52	131,4	44	46	38,5	1	2	1,30
	20	E346958420120	120	52	188,4	101	46	95,5	1	2	2,20
	25	E346958425100	100	63	168,4	–	54	76,5	2	2	2,18
	32	E346958432100	100	72	168,4	–	58	76,5	2	2	2,53

Spare Parts

For d	Locking screw
6	951C0610
8	951C0810
10	951C1012
12-14	951C1216
16-18	951C1416
20	951C1616
25	951C1820
32	951C2020

Please check availability in current price and stock-list



- Direct run-out 3 µm maximum
- Weldon d 16, 20, 25, 32 and 40 with ground face (Seco-Weldon compatible)

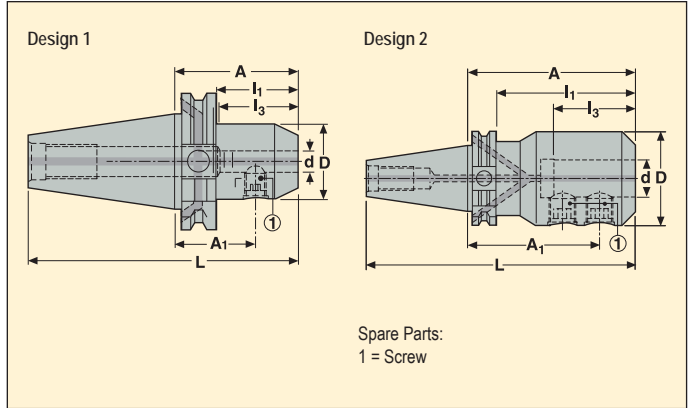

Taper	d mm	Part No.	Dimensions in mm						Design	Balancing	
			A	D	L	I ₁	I ₃	A ₁			
DIN50 ADB	6	E34715840663	63	25	164,7	44	27	45,5	1	2	2,62
	6	E347158406120	120	25	221,7	101	27	102,5	1	2	2,82
	8	E34715840863	63	28	164,7	44	30	45,5	1	2	2,66
	8	E347158408120	120	28	221,7	101	30	102,5	1	2	2,89
	10	E34715841063	63	35	164,7	44	36	43,5	1	2	2,73
	10	E347158410120	120	35	221,7	101	36	100,5	1	2	2,98
	12	E34715841263	63	42	164,7	44	43	41,0	1	2	2,86
	12	E347158412120	120	42	221,7	120	43	98,0	1	2	3,32
	14	E34715841463	63	44	164,7	44	43	41,0	1	2	3,05
	16	E34715841663	63	48	164,7	44	46	39,5	1	2	3,10
	16	E347158416120	120	48	221,7	101	46	96,5	1	2	3,60
	16	E347158416160	160	48	261,7	141	46	136,5	1	2	4,04
	18	E34715841863	63	50	164,7	44	46	39,5	1	2	3,15
	20	E34715842063	63	52	164,7	44	48	38,5	1	2	3,03
	20	E347158420120	120	52	221,7	101	48	95,5	1	2	4,05
	25	E34715842580	80	65	181,7	61	54	56,5	2	2	3,66
	25	E347158425120	120	65	221,7	101	54	96,5	2	2	4,68
	32	E347158432100	100	72	201,7	81	58	76,5	2	2	4,46
	40	E347158440120	120	80	221,7	101	68	90,5	2	2	5,70
	50	E347158450130	130	100	231,7	–	78	95,5	2	2	7,19

Spare Parts

For d	Locking screw
6	951C0610
8	951C0810
10	951C1012
12-14	951C1216
16-18	951C1416
20	951C1616
25	951C1820
32-40	951C2020
50	951C2425

Please check availability in current price and stock-list

Monobloc holders DIN 69871

EPB 5842 – Side lock holders, Weldon short

DIN 69871-ADB



- Direct run-out 5 µm maximum
- Weldon d 16, 20, 25, 32 and 40 with ground face (Seco-Weldon compatible)

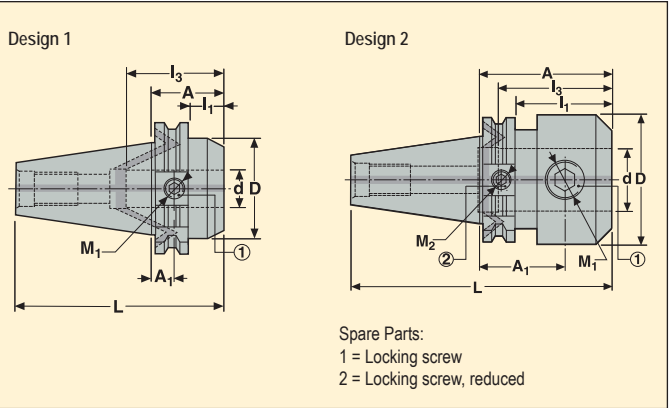

Taper	d mm	Part No.	Dimensions in mm						M ₁ mm	M ₂ mm	Design	Balancing	KG
			A	D	L	I ₁	I ₃	A ₁					
DIN40 ADB	20	E346958422035	35	50	103,4	15,9	48	10,5	M16	–	1	2	0,90
	25	E346958422560	60	50	128,4	40,9	54	36,5	M18x2	M14	2	2	1,20
	32	E346958423275	75	72	143,4	55,9	58	51,5	M20x2	M14	2	2	1,80
DIN50 ADB	25	E347158422560	60	65	161,5	40,9	54	36,5	M18x2	M14	2	2	3,35
DIN50 ADB/ CAT50	32	E347858423260	60	72	161,5	40,9	58	36,5	M20x2	M14	2	2	3,32

Spare Parts

For d	Locking screw	Locking screw, reduced
20/E3469	951C1614	–
25/E3469	951C1814	–
32/E3469	951C2020	950A1410
25/E3471	951C1820	950A1416
32/E3478	951C2020	950A1416

Please check availability in current price and stock-list



- Run-out 3 µm at 3xd (direct run-out 3 µm) maximum
- Delivered with one stop screw

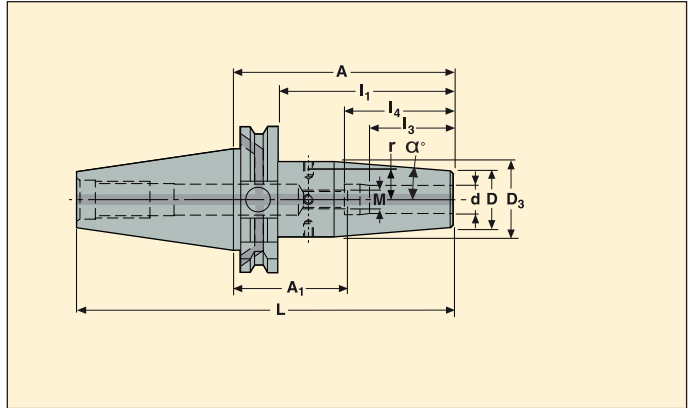

Taper	d mm	Part No.	Dimensions in mm								M mm	α°	r mm	Balancing	KG
			A	D	D ₃	L	I ₁	I ₃	I ₄	A ₁ min-max					
DIN40 ADB	6	E346956030680	80	21	27	148,4	61	22	37,5	44-54	M5	4,5	10,5	1	1,01
	6	E3469560306120	120	21	27	188,4	101	22	37,5	84-94	M5	4,5	10,5	1	1,18
	6	E3469560306160	160	21	27	228,4	141	22	37,5	124-134	M5	4,5	10,5	1	1,40
	8	E346956030880	80	21	27	148,4	61	26	37,5	44-54	M6	4,5	10,5	1	1,00
	8	E3469560308120	120	21	27	188,4	101	26	37,5	84-94	M6	4,5	10,5	1	1,20
	8	E3469560308160	160	21	27	228,4	141	26	37,5	124-134	M6	4,5	10,5	1	1,32
	10	E346956031080	80	24	32	148,4	61	31	42,5	39-49	M8x1	4,5	13,0	1	1,06
	10	E3469560310120	120	24	32	188,4	101	31	42,5	79-89	M8x1	4,5	13,0	1	1,30
	10	E3469560310160	160	24	32	228,4	141	31	42,5	119-129	M8x1	4,5	13,0	1	1,52
	12	E346956031280	80	24	32	148,4	61	34	47,5	34-44	M10x1	4,5	13,0	1	1,04
	12	E3469560312120	120	24	32	188,4	101	34	47,5	74-84	M10x1	4,5	13,0	1	1,27
	12	E3469560312160	160	24	32	228,4	141	34	47,5	114-124	M10x1	4,5	13,0	1	1,50
	14	E346956031480	80	27	34	148,4	61	34	47,5	34-44	M10x1	4,5	14,0	1	1,09
	14	E3469560314120	120	27	34	188,4	101	34	47,5	74-84	M10x1	4,5	14,0	1	1,35
	16	E346956031680	80	27	34	148,4	61	39	50,5	31-41	M12x1	4,5	14,0	1	1,06
	16	E3469560316120	120	27	34	188,4	101	39	50,5	71-81	M12x1	4,5	14,0	1	1,40
	16	E3469560316160	160	27	34	228,4	141	39	50,5	111-121	M12x1	4,5	14,0	1	1,60
	18	E346956031880	80	33	42	148,4	61	39	50,5	31-41	M12x1	4,5	18,0	1	1,30
	20	E346956032080	80	33	42	148,4	61	41	52,5	29-39	M16x1	4,5	18,0	1	1,15
	20	E3469560320120	120	33	42	188,4	101	47	52,5	69-79	M16x1	4,5	18,0	1	1,60
25	E3469560325100	100	44	53	168,4	81	47	58,5	43-53	M16x1	4,5	23,5	1	1,70	

For Shrinkfit extensions, see page(s) 294

Accessories

For d	Balancing screws
6	90ZQ01
8	90ZQ01
10	90ZQ01
12-14	90ZQ01
16-18	90ZQ01
20-25	90ZQ01

Spare Parts

For d	Stop screw
6	19BDR05165
8	19BDR06165
10	19BDR08165
12-14	19BDR10165
16-18	19BDR12165
20-25	19BDR16165

Please check availability in current price and stock-list

For stop screw setting adapters, see page(s) 336



- Run-out 3 µm at 3xd (direct run-out 3 µm) maximum
- Delivered with one stop screw

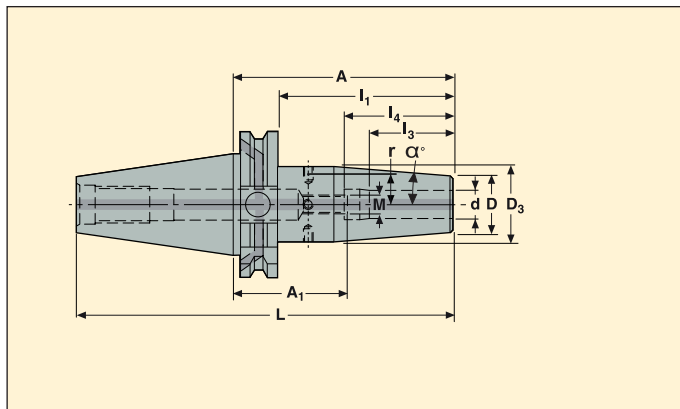

Taper	d mm	Part No.	Dimensions in mm								M mm	α°	r mm	Balancing	KG
			A	D	D ₃	L	I ₁	I ₃	I ₄	A ₁ min-max					
DIN50 ADB	6	E347156030680	80	21	27	182	61	22	37,5	44-54	M5	4,5	10,5	1	2,79
	6	E3471560306160	160	21	27	262	141	22	37,5	124-134	M5	4,5	10,5	1	3,05
	8	E347156030880	80	21	27	182	61	26	37,5	44-54	M6	4,5	10,5	1	2,77
	8	E3471560308160	160	21	27	262	141	26	37,5	124-134	M6	4,5	10,5	1	3,04
	10	E347156031080	80	24	32	182	61	31	42,5	39-49	M8x1	4,5	13,0	1	2,83
	10	E3471560310160	160	24	32	262	141	31	42,5	119-129	M8x1	4,5	13,0	1	3,27
	12	E347156031280	80	24	32	182	61	34	47,5	34-44	M10x1	4,5	13,0	1	2,81
	12	E3471560312160	160	24	32	262	141	34	47,5	114-124	M10x1	4,5	13,0	1	3,25
	14	E347156031480	80	27	34	182	61	34	47,5	34-44	M10x1	4,5	14,0	1	2,86
	16	E347156031680	80	27	34	182	61	39	50,5	31-41	M12x1	4,5	14,0	1	2,83
	16	E3471560316160	160	27	34	262	141	39	50,5	111-121	M12x1	4,5	14,0	1	3,40
	18	E347156031880	80	33	42	182	61	39	50,5	31-41	M12x1	4,5	18,0	1	3,00
	20	E347156032080	80	33	42	182	61	41	52,5	29-39	M16x1	4,5	18,0	1	2,92
	20	E3471560320160	160	33	42	262	141	41	52,5	109-119	M16x1	4,5	18,0	1	3,70
	25	E347156032590	90	44	53	192	71	47	58,5	33-43	M16x1	4,5	23,5	1	3,35
	25	E3471560325160	160	44	53	262	141	47	58,5	103-113	M16x1	4,5	23,5	1	4,47
	32	E347156033290	90	44	53	192	71	51	62,5	29-39	M16x1	4,5	23,5	1	3,18

For Shrinkfit extensions, see page(s) 294

Accessories

For d	Balancing screws
6	90ZQ01
8	90ZQ01
10	90ZQ01
12-14	90ZQ01
16-18	90ZQ01
20-32	90ZQ01

Spare Parts

For d	Stop screw
6	19BDR05165
8	19BDR06165
10	19BDR08165
12-14	19BDR10165
16-18	19BDR12165
20-32	19BDR16165

Please check availability in current price and stock-list

For stop screw setting adapters, see page(s) 336



- Reinforced design with wider front and tapered body
- Run-out 3 µm maximum at 3xd
- With coolant supply channels towards the tool (plugged)

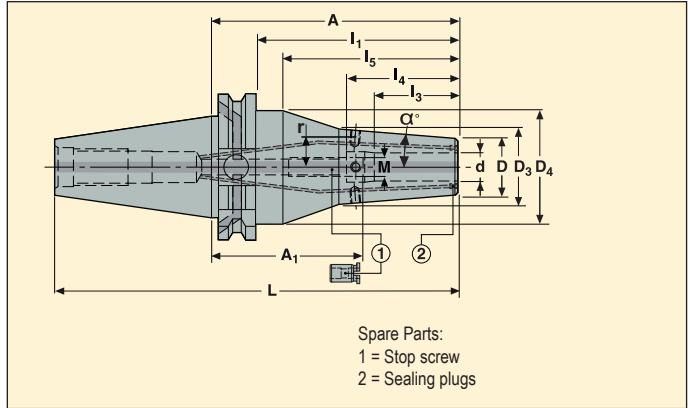

Taper	d mm	Part No.	Dimensions in mm											M mm	α°	**	r mm	Balancing	KG
			A*	D	D ₃	D ₄	L	I ₁	I ₃	I ₄	I ₅	A ₁ min-max							
DIN40 ADB	6	E3469560006130	130	24	32,2	49,5	198,4	111	22	37,5	95	94-104	M5	4,5		12,0	1	1,70	
	8	E3469560008130	130	24	32,2	49,5	198,4	111	26	37,5	95	94-104	M6	4,5		12,0	1	1,70	
	10	E346956001065	65	27	34,3	-	133,4	46	31	42,5	-	24-34	M8x1	4,5	**	13,5	1	1,05	
	10	E3469560010130	130	27	35,2	49,5	198,4	111	31	42,5	95	89-99	M8x1	4,5		13,5	1	1,80	
	12	E346956001265	65	27	34,3	-	133,4	46	34	47,5	-	19-29	M10x1	4,5	**	13,5	1	1,05	
	12	E3469560012130	130	27	35,2	49,5	198,4	111	34	47,5	95	84-94	M10x1	4,5		13,5	1	1,75	
	16	E346956001665	65	33	40,3	-	133,4	46	39	50,5	-	16-26	M12x1	4,5	**	17,0	1	1,10	
	16	E3469560016130	130	33	42,2	49,5	198,4	111	39	50,5	95	81-91	M12x1	4,5		17,0	1	1,90	
	20	E346956002065	65	44	-	49,5	133,4	46	41	52,5	-	14-24	M16x1	4,5	**	-	1	1,27	
	20	E3469560020130	130	44	58,0	49,5	198,4	111	41	52,5	95	79-89	M16x1	4,5		21,5	1	2,36	
	25	E346956002575	75	48	55,5	49,5	143,4	56	47	58,5	40	18-28	M16x1	4,5	**	-	1	1,45	
	25	E3469560025130	130	48	63,0	49,5	198,4	111	47	58,5	95	73-83	M16x1	4,5		25,0	1	2,59	

* E346956001665, E346956002065 and E346956002575: Extra-short holders requiring a dedicated Easyshrink® cooling contact bush type "5600 extra short", see page(s) 337. ** Holder without threaded holes for balancing screws

Accessories

For d	Balancing screws
6	90ZQ01
8	90ZQ01
10	90ZQ01
12	90ZQ01
16	90ZQ01
20-25	90ZQ01

Spare Parts

For d	Sealing plugs	Stop screw
6	90AI03	19BDR05165
8	90AI03	19BDR06165
10	90AI03	19BDR08165
12	90AI03	19BDR10165
16	90AI03	19BDR12165
20-25	90AI04	19BDR16165

Please check availability in current price and stock-list
For stop end screw setting adapters, see page(s) 336



- Reinforced design with wider front and tapered body
- Run-out 3 µm maximum at 3xd
- With coolant supply channels towards the tool (plugged)

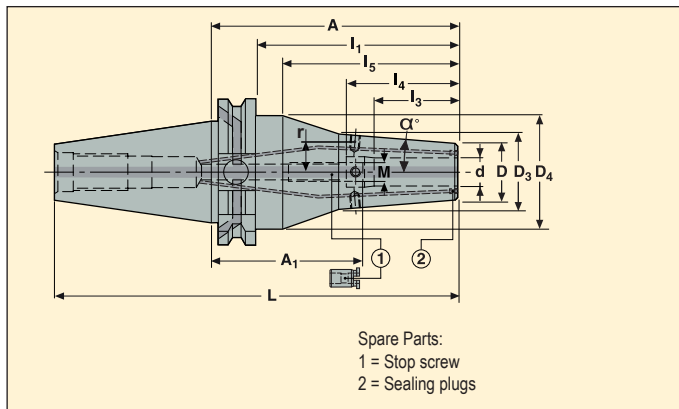

Taper	d mm	Part No.	Dimensions in mm										M mm	α°	r mm	Balancing	KG
			A*	D	D ₃	D ₄	L	I ₁	I ₃	I ₄	I ₅	A ₁ min-max					
DIN50 ADB	6	E3471560006160	160	24	32,2	79,5	261,7	141	22	37,5	125	124-134	M5	4,5	12,0	1	4,85
	8	E3471560008160	160	24	32,2	79,5	261,7	141	26	37,5	125	124-134	M6	4,5	12,0	1	4,85
	10	E347156001080	80	27	36,6	–	181,7	61	31	42,5	–	39-49	M8x1	4,5	13,5	1	3,00
	10	E3471560010160	160	27	35,2	79,5	261,7	141	31	42,5	125	119-129	M8x1	4,5	13,5	1	4,95
	10	E3471560010200	200	27	35,2	79,5	301,7	181	31	42,5	165	159-169	M8x1	4,5	13,5	1	5,80
	12	E347156001280	80	27	36,6	–	181,7	61	34	47,5	–	34-44	M10x1	4,5	13,5	1	2,95
	12	E3471560012160	160	27	35,2	79,5	301,7	181	34	47,5	125	114-124	M10x1	4,5	13,5	1	4,95
	12	E3471560012200	200	27	35,2	79,5	301,7	181	34	47,5	165	154-164	M10x1	4,5	13,5	1	5,75
	16	E347156001680	80	33	42,6	–	181,7	61	39	50,5	–	31-41	M12x1	4,5	17,0	1	3,05
	16	E3471560016160	160	33	42,2	79,5	261,7	141	39	50,5	125	111-121	M12x1	4,5	17,0	1	5,10
	16	E3471560016200	200	33	42,2	79,5	301,7	181	39	50,5	165	151-161	M12x1	4,5	17,0	1	6,00
	20	E347156002080	80	44	53,6	–	181,7	61	41	52,5	–	29-39	M16x1	4,5	21,5	1	3,26
	20	E3471560020160	160	44	53,2	79,5	261,7	141	41	52,5	125	109-119	M16x1	4,5	21,5	1	5,60
	20	E3471560020200	200	44	53,2	79,5	301,7	181	41	52,5	165	149-159	M16x1	4,5	21,5	1	6,67
	25	E347156002590	90	48	61,2	–	191,7	71	47	58,5	–	33-43	M16x1	4,5	25,0	1	3,67
	25	E3471560025160	160	48	59,1	79,5	261,7	141	47	58,5	125	103-113	M16x1	4,5	25,0	1	5,87
	25	E3471560025200	200	48	59,1	79,5	301,7	181	47	58,5	165	143-153	M16x1	4,5	25,0	1	7,02
	32	E347156003290	90	48	61,2	–	191,7	71	51	62,5	–	29-39	M16x1	4,5	25,0	1	3,50
	32	E3471560032160	160	48	59,1	79,5	261,7	141	51	62,5	125	99-109	M16x1	4,5	25,0	1	5,70
	32	E3471560032200	200	48	59,1	79,5	301,7	181	51	62,5	165	139-149	M16x1	4,5	25,0	1	6,85

* E3471 5600 2080 = Extra-short holder requiring a dedicated Easysrink® cooling contact bush type "5600 extra short", see page(s) 337

Accessories

For d	Balancing screws
6	90ZQ01
8	90ZQ01
10	90ZQ01
12	90ZQ01
16	90ZQ01
20-32	90ZQ01

Spare Parts

For d	Sealing plugs	Stop screw
6	90AI03	19BDR05165
8	90AI03	19BDR06165
10	90AI03	19BDR08165
12	90AI03	19BDR10165
16	90AI03	19BDR12165
20-32	90AI04	19BDR16165

Please check availability in current price and stock-list
For stop end screw setting adapters, see page(s) 336



- With Safe-Lock™ tool pull-out protection system
- Reinforced design of EPB 5600
- Run-out 3 μm maximum at 3xd
- With coolant supply channels towards the tool (plugged)

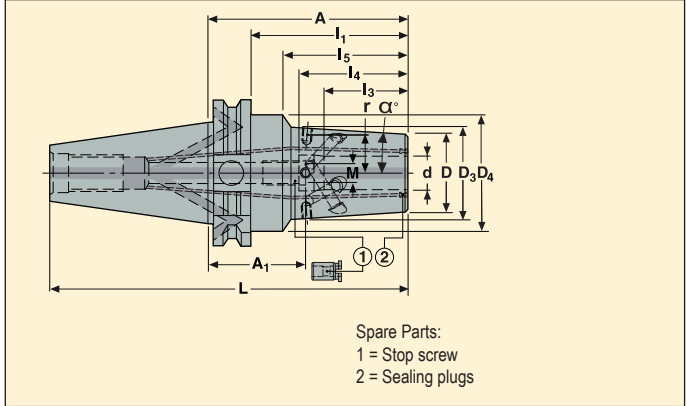

Taper	d mm	Part No.	Dimensions in mm										M	mm	α°	**	r mm	Balancing	KG
			A*	D	D ₃	D ₄	L	I ₁	I ₃	I ₄	I ₅	A ₁ min-max							
DIN40 ADB	12	E346956001265P	65	27	34,3	–	133,4	45,9	34	47,5	–	19-27,5	M10x1	4,5			13,5	1	1,10
	16	E346956001665P	65	33	40,3	–	133,4	45,9	39	50,5	–	16-24	M12x1	4,5			17,0	1	1,10
	20	E346956002065P	65	44	–	49,5	133,4	45,9	41	52,5	–	14-22	M16x1	4,5	**	–	–	1	1,30
	25	E346956002575P	75	48	55,5	49,5	143,4	55,9	47	58,5	40	18-26	M16x1	4,5	**	–	–	1	1,50
DIN50 ADB	12	E347156001280P	80	27	36,6	–	181,8	60,9	34	47,5	–	34-42,5	M10x1	4,5			13,5	1	3,00
	16	E347156001680P	80	33	42,6	–	181,8	60,9	39	50,5	–	31-39	M12x1	4,5			17,0	1	3,10
	20	E347156002080P	80	44	53,6	–	181,8	60,9	41	52,5	–	29-39	M16x1	4,5			21,5	1	3,40
	25	E347156002590P	90	48	61,2	–	191,8	70,9	47	58,5	–	33-41	M16x1	4,5			25,0	1	3,70
	32	E347156003290P	90	48	61,2	–	191,8	70,9	51	62,5	–	29-39	M16x1	4,5			25,0	1	3,50

* E346956001665P, E346956002065P, E346956002575P and E347156002080P: Extra-short holder requiring a dedicated Easysrink® cooling contact bush type "5600 extra short", see page(s) 337, ** Holder without threaded holes for balancing screws

Accessories

For d	Balancing screws
12	90ZQ01
16	90ZQ01
20-32	90ZQ01

Spare Parts

For d	Sealing plugs	Stop screw
12	90AI03	–
16	90AI03	–
20-32	90AI04	19BDR16165

Please check availability in current price and stock-list

(-) For d 12 and 16 mm, stop screw not removable/replaceable by the user, please request a repair process

Monobloc holders DIN 69871



EPB 5801 – Shrinkfit holders, Mould and Die type

DIN 69871-ADB/ CAT Combined



- Run-out 3 μm at 3xd (direct run-out 3μm) maximum

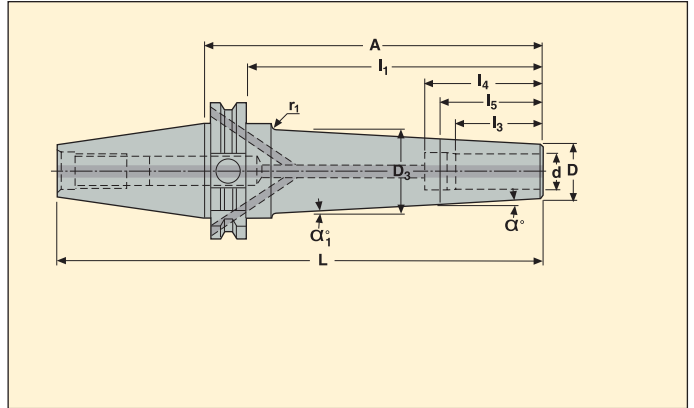

Taper	d mm	Part No.	Dimensions in mm									α°	α ₁ °	r ₁ mm	Balancing	KG
			A	D	D ₃	L	l ₁	l ₃	l ₄	l ₅						
DIN40 ADB/ CAT40	3	E347658010380	80	9	15	148,4	61	13	–	25	3	5	7	1	1,00	
	3	E3476580103140	140	9	26	208,4	120	13	–	25	3	5	7	1	1,12	
	4	E347658010480	80	10	16	148,4	61	15	–	25	3	5	7	1	1,00	
	4	E3476580104140	140	10	27	208,4	120	15	–	25	3	5	7	1	1,13	
	6	E347658010680	80	12	17	148,4	61	26	40	–	3	–	7	1	1,02	
	6	E3476580106140	140	12	30	208,4	120	26	40	32	3	5	7	1	1,17	
	8	E347658010880	80	16	21	148,4	61	30	44	–	3	–	7	1	1,04	
	8	E3476580108140	140	16	32	208,4	120	30	44	36	3	5	6	1	1,23	
	10	E347658011080	80	18	23	148,4	61	32	45	–	3	–	7	1	1,05	
	10	E3476580110160	160	18	38	228,4	140	32	45	38	3	5	2,5	1	1,44	
	12	E347658011280	80	20	25	148,4	61	34	46	–	3	–	7	1	1,06	
	12	E3476580112170	170	20	41	238,4	150	34	46	40	3	5	–	1	1,62	

Please check availability in current price and stock-list
For Shrinkfit extensions, see page(s) 294



- Run-out 3 μm maximum at 3xd
- High transmittable torque
- High RPM suitable

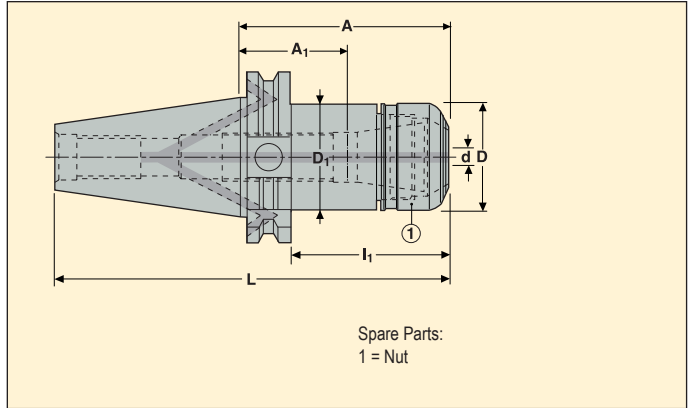

Taper	Capacity d mm	Part No.	Chuck & Collet Size	Dimensions in mm						Balancing	
				A	D	D ₁	L	I ₁	A ₁ min-max*		
DIN40 ADB	1-10	E346956721670	HP 16	70	30	30	138,4	51	25-40	1	1,0
	1-10	E3469567216130	HP 16	130	30	30	198,4	111	85-100	1	1,28
	2-16	E346956722570	HP 25	70	40	40	138,4	51	16-32	1	1,1
	2-16	E3469567225160	HP 25	160	40	40	228,4	141	95-122	1	1,86
	2-20	E346956723270	HP 32	70	50	50	138,4	51	16-22	1	1,24
DIN50 ADB	2-16	E347156722580	HP 25	80	40	40	181,75	60,9	15-42	1	2,96
	2-20	E347156723280	HP 32	80	50	50	181,75	60,9	16-32	1	3,15

For ER HP collets type 5672, see page(s) 297-300

* A1 setting length onto stop screw when possible, or total available setting length for chucks without thread for stop end screw.

Accessories**

For size	Socket	Spanner	Stop screw	Torque key
HP 16	03EF567216	03B567216	19B58711	03DYD010100
HP 25	03EF567225	03B567225	19B58718	03DYD020200
HP 32	03EF567232	03B567232	19B58722	03DYD020200

Spare Parts

For size	Nut
HP 16	08B567216
HP 25	08B567225
HP 32	08B567232

Please check availability in current price and stock-list

** When using a stop end screw, its tapered contact onto the tool shank can increase the tool run-out defect

*** For tightening torques, see Guide pages



- Run-out 4 μm maximum at 3xd

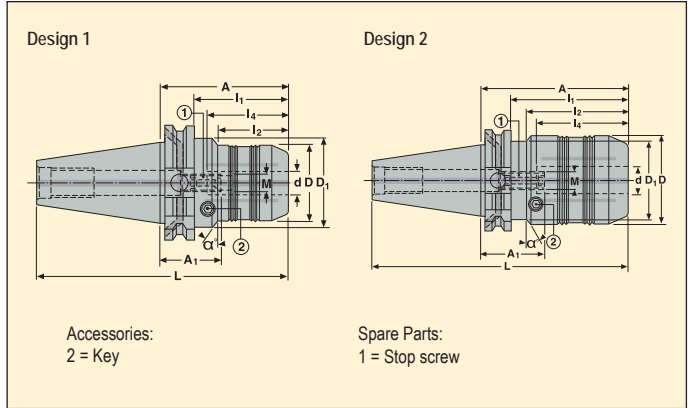

Taper	d mm	Part No.	Dimensions in mm								M mm	Design	α°	Balancing	KG
			A	D	D ₁	L	l ₁	l ₂	l ₄	A ₁ min-max					
DIN40 ADB	12	E346958351275	75	48,0	–	143,4	56	–	47	28-38	M10	1	–	1	1,49
	20	E346958352080	80	62,5	49,5	148,4	61	45	52	28-38	M10	2	0	1	1,98
DIN50 ADB	12	E347158351275	75	48,0	63	176,7	56	38	47	28-38	M10	1	30	1	3,39
	20	E347158352080	80	62,5	–	181,7	61	–	52	28-38	M10	1	–	1	4,00
	32	E347158353280	80	80,0	–	181,7	61	–	63	17-27	M10	1	–	1	4,53

For reduction sleeves and control gauges, see page(s) 295-296

Accessories

For d	Locking key
12-32	03HXL06

Spare Parts

For d	Stop screw
12-32	19LS1016A

Please check availability in current price and stock-list



- Run-out 3 μm maximum at 3x ϕ

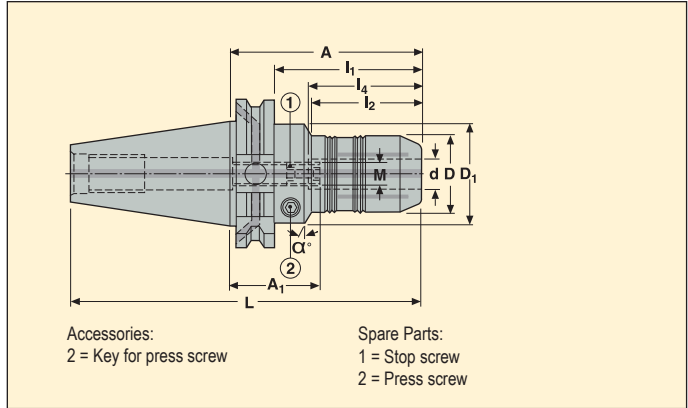

Taper	d mm	Part No.	Dimensions in mm								M mm	α°	Balancing	
			A	D	D ₁	L	I ₁	I ₂	I ₄	A ₁ min-max				
DIN40 ADB	6	E346958340680	80	26	50	148,4	61	23	38	42-52	M5	30	1	1,36
	8	E346958340880	80	28	50	148,4	61	24	38	42-52	M5	30	1	1,36
	10	E346958341080	80	30	50	148,4	61	34	42	38-48	M8	30	1	1,27
	12	E346958341280	80	32	50	148,4	61	40	47	33-43	M10	30	1	1,32
	14	E346958341480	80	34	50	148,4	61	40	47	33-43	M10	30	1	1,30
	16	E346958341680	80	38	50	148,4	61	46	50	30-40	M10	30	1	1,40
	20	E346958342080	80	42	50	148,4	61	47	52	28-38	M10	30	1	1,40
25	E346958342595	95	58	50	163,4	76	60	58	37-47	M10	60	1	1,93	
DIN50 ADB	12	E347158341280	80	32	50	181,7	61	40	47	33-43	M10	30	1	5,00
	20	E347158342080	80	42	50	181,7	61	47	52	28-38	M10	30	1	5,40
	25	E347158342595	95	58	70	196,7	76	50	58	37-47	M10	30	1	3,98
	32	E347158343290	90	64	70	191,7	71	50	63	27-37	M10	30	1	5,70

For reduction sleeves, see page(s) 295 and control gauges, see page(s) 296

Accessories

For d	Locking key
6-8	H04-4
10	H04-4
12	H04-4
14-32	H04-4

Spare Parts

For d	Press screw	Stop screw
6-8	950AF0810008	19LS0520A
10	950AF0810008	19LS0820A
12	950AF0810008	19LS1020A
14-32	950AF1010010	19LS1020A

Please check availability in current price and stock-list



- Run-out 10 µm maximum at 3xd

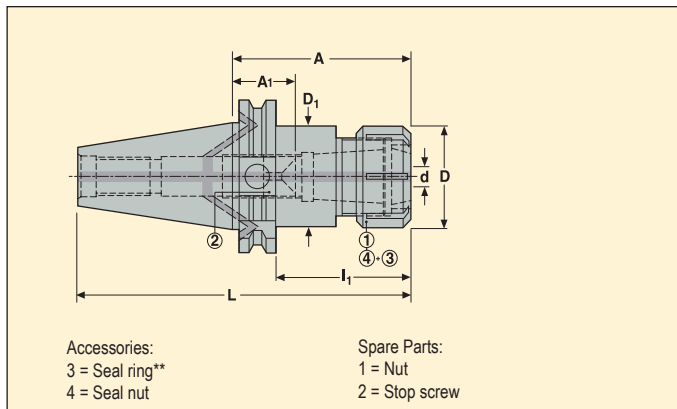

Taper	Capacity d mm	Part No.	Chuck & Collet Size	Dimensions in mm						A ₁ min-max	*	Balancing	KG
				A	D	D ₁	L	I ₁					
DIN40 ADB	0,5-10	E346956751670	ER 16	70	32	32	138,4	51	22-38		1	0,99	
	0,5-10	E3469567516120	ER 16	120	32	32	188,4	101	72-88		1	1,29	
	1-16	E346956752570	ER 25	70	42	42	138,4	51	11-32		1	1,1	
	1-16	E3469567525120	ER 25	120	42	42	188,4	101	51-82		1	1,61	
	2-20	E346956753270	ER 32	70	50	50	138,4	51	12-30		1	1,17	
	2-20	E3469567532120	ER 32	120	50	50	188,4	101	52-80		1	1,86	
	3-26	E446956754070	ER 40*	70	63	50	138,4	51	0-25	*	1	1,2	
DIN50 ADB	0,5-10	E347156751670	ER 16	70	32	32	171,7	51	22-38		2	2,73	
	0,5-10	E3471567516120	ER 16	120	32	32	221,7	101	72-88		2	2,97	
	1-16	E347156752590	ER 25	90	42	42	191,7	71	21-52		2	3,02	
	2-20	E347156753290	ER 32	90	50	50	191,7	71	22-50		2	3,2	
	2-20	E3471567532150	ER 32	150	50	50	251,7	131	82-110		2	3,98	
	3-26	E3471567540100	ER 40	100	63	63	201,7	81	28-55		2	3,76	

For ER collets, see page(s) 302-303

ER extensions, see page(s) 301

* Chuck ER40/A70 is type AD (E4469) without flange coolant through, instead type ADB (E3469)

Accessories**

For size	Seal nut	Spanner
ER 16	08B587516IC	03B587516
ER 25	08B587525IC	03B587525
ER 32	08B587532IC	03B587532
ER 40	08B587540IC	03B587540
ER 40*	08B587540IC	03B587540

Spare Parts

For size	Nut	Stop screw
ER 16	08B587516X	19B58711
ER 25	08B587525X	19B58718
ER 32	08B587532X	19B58722
ER 40	08B587540X	19B58730
ER 40*	08B587540X	19B58730

Please check availability in current price and stock-list

** For ER sealing rings, see page(s) 304



- Direct run-out 15 µm at 3rd maximum

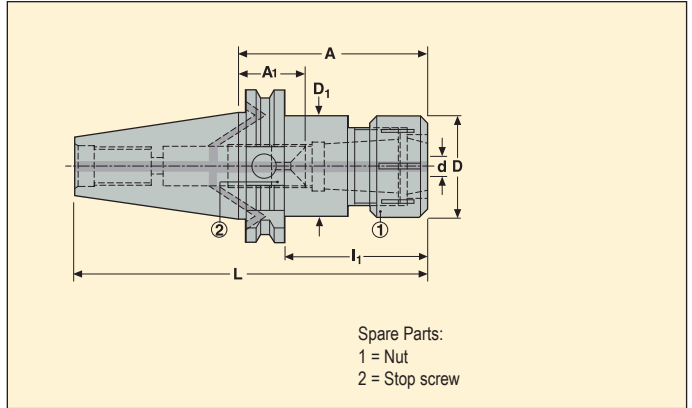

Taper	Capacity d mm	Part No.	Chuck & Collet Size	Dimensions in mm						Balancing	
				A	D	D ₁	L	I ₁	A ₁ min-max		
DIN40 ADB	4-32	E346958733290	OZ 32	90	72	50	158,4	71	15-25	2	1,72
DIN50 ADB	4-32	E347158733273	OZ 32	73	72	72	174,7	54	0-8	2	3,28

For OZ collets, see page(s) 305

Accessories

For taper	Key
DIN40 ADB	03B587332
DIN50 ADB	03B587332

Spare Parts

For taper	Nut	Stop screw
DIN40 ADB	08B587332	19B58727
DIN50 ADB	08B587332	19B58735

Please check availability in current price and stock-list



- Run-out 40 μm maximum at 2,5xd

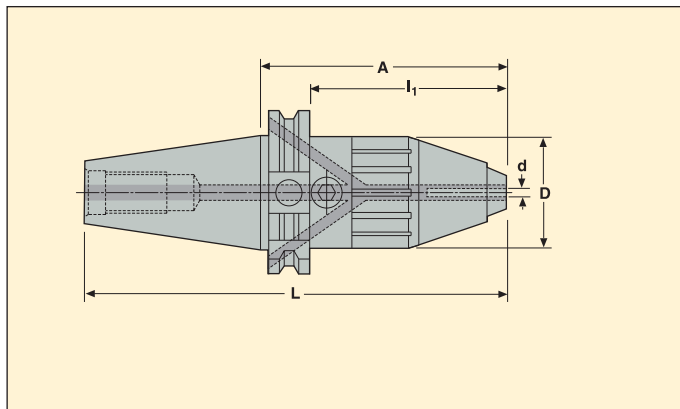

Taper	Capacity d mm	Part No.	Dimensions in mm				Balancing	
			A	D	L	I ₁		
DIN40 ADB	1-13	E3469508513	96	43	164,4	77	2	1,24
	2,5-16	E3471508516	112	56	213,7	93	2	3,68
DIN50 ADB								

Accessories

For Capacity d	Key
1-13	H06-4
2,5-16	H06-4

Please check availability in current price and stock-list

Monobloc holders DIN 69871



EPB 5867 – Tapping chucks for synchronized tapping, with micro-compensation



- Inbuilt axial micro flexure (+/- 0,5 mm) prevents from tapping tap stress
- Tap fitting based on ER tapping collets with square drive
- Maximum coolant pressure 80 bar

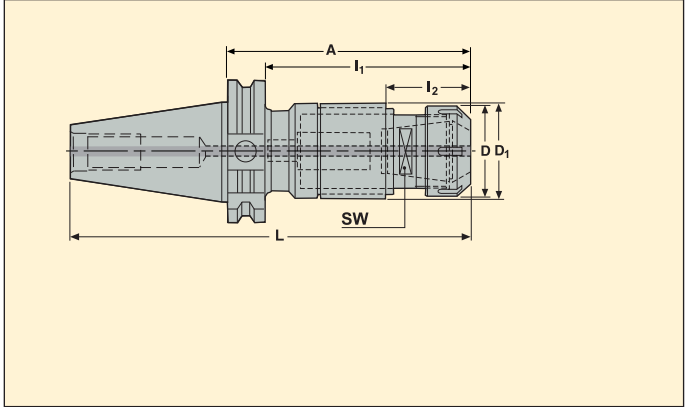

Taper	Tapping range	Part No.	Size	Dimensions in mm							Balancing	
				A	D	D ₁	L	I ₁	I ₂	SW		
DIN40 AD	M4-M12	E4469586720102	ER 20	102,2	33,7	35	170,4	83,2	40,3	22	–	1,30
	M8-M20	E4469586725122	ER 25	121,6	42	44	189,9	102,5	42,1	28	–	1,70
DIN50 AD	M4-M12	E4471586720106	ER 20	106,2	33,7	35	207,8	87,2	40,3	22	–	3,00
	M8-M20	E4471586725126	ER 25	125,6	42	44	227,2	106,5	42,1	28	–	3,40
	M16-M30	E4471586740155	ER 40	155	62,7	62	256,6	135,9	52	39	–	4,70

For ER tapping collets with square drive, see page(s) 308

Accessories

Spare Parts

For size	Locking key	Spanner
ER 20	5680092-04	03B587520UM
ER 25	5680092-05	03B587525
ER 40	5680092-06	03B587540

For size	Nut
ER 20	5533051-02
ER 25	5533051-03
ER 40	5533051-05

Please check availability in current price and stock-list
 For EPB 5867 sealing rings, see page(s) 309

Monobloc holders DIN 69871

EPB 5283 – Quick change tapping chucks with axial compensation

DIN 69871-A

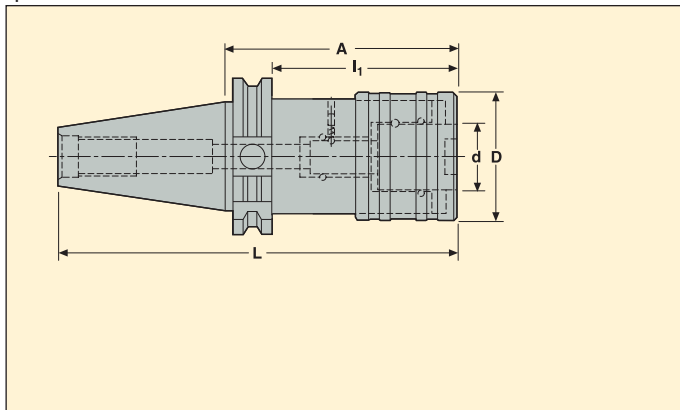

- With extension and compression

Taper	Tapping range	Part No.	For tap adapter		Dimensions in mm						
			Size	d mm	Compression	Extension	A	D	L	I ₁	
DIN40 A	M3-M12	ET446952832	2	19	7,5	7,5	70	39	138,4	51	1,11
	M8-M20	ET446952833	3	31	12,5	12,5	100	59	168,4	81	1,82
DIN50 A	M3-M12	ET447152832	2	19	7,5	7,5	70	39	171,7	51	2,89
	M8-M20	ET447152833	3	31	12,5	12,5	100	59	201,7	81	3,66
	M14-M33	ET447152834	4	48	20	20	140	84	241,7	121	5,64

Please check availability in current price and stock-list
For quick change tap adapters, see page(s) 311-312



- Direct run-out 5 µm maximum
- No compensation

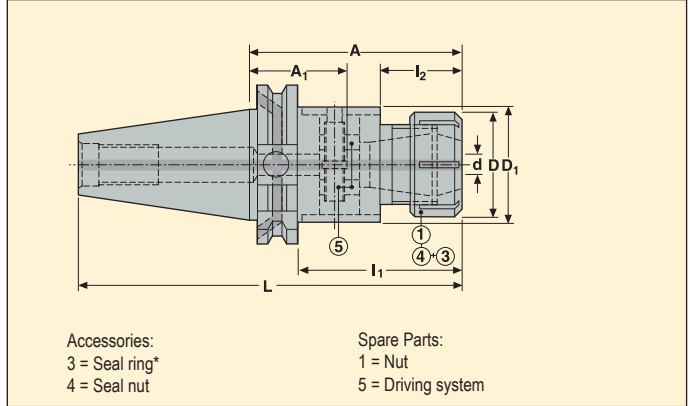

Taper	Tapping range	Part No.	For tap adapter		Dimensions in mm							Balancing	KG
			Size	d mm	A	D	D ₁	L	I ₁	I ₂	A ₁		
DIN40 ADB	M5-M20	E346958652585	ER 25	1-16	85	42	42	153,4	66	–	39,5	2	1,22
	M5-M30	E3469586532125	ER 32	2-20	125	50	63	193,4	106	37	68,5	2	2,3
DIN50 ADB	M5-M30	E3471586532105	ER 32	2-20	105	50	63	206,7	86	37	48,5	2	3,7
	M12-M33	E3471586540110	ER 40	3-26	110	63	63	211,7	91	–	47,5	2	3,88

For ER collets, see page(s) 302-303

Accessories*

For size	Key	Seal nut
ER 25	03B587525	08B587525IC
ER 32	03B587532	08B587532IC
ER 40	03B587540	08B587540IC

Spare Parts

For size	Driving system	Nut
ER 25	90T586525	08B587525X
ER 32	90T586532	08B587532X
ER 40	90T586532	08B587540X

Please check availability in current price and stock-list
* For ER type sealing rings, see page(s) 304

Monobloc holders DIN 69871

EPB 543 - Taper adapters SA - DIN 69871-BT-CAT

DIN 69871-A



• Direct run-out 5 μm maximum

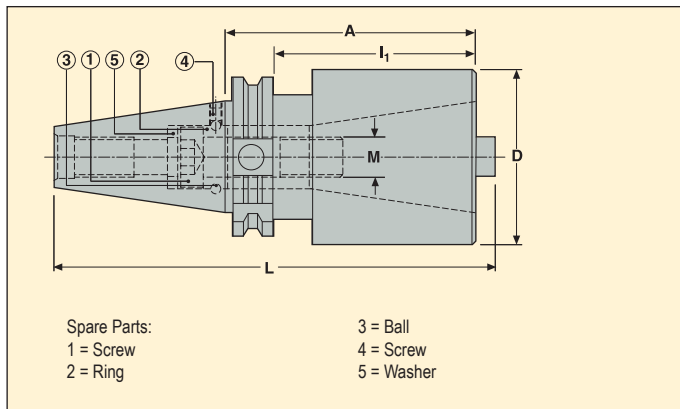

Taper	For taper	Part No.	Dimensions in mm				M mm	Balancing	
			A	D	L	I ₁			
DIN50 A	40 DIN 69871/BT/CAT	E44715434070T	70	70	179,7	51	M16	2	3,66
	50 DIN 69871/BT/CAT	E447154350120T	120	98	234,2	-	M24	2	6,20

Spare Parts

For	Balls	Plug	Ring	Screw	Washer
..4070T	901B04	950A0505	02B54240	950E1670	15B54240
..50120T	901B05	950A0806	02B54250	19B172490	-

Please check availability in current price and stock-list



- Direct run-out 5 μm maximum

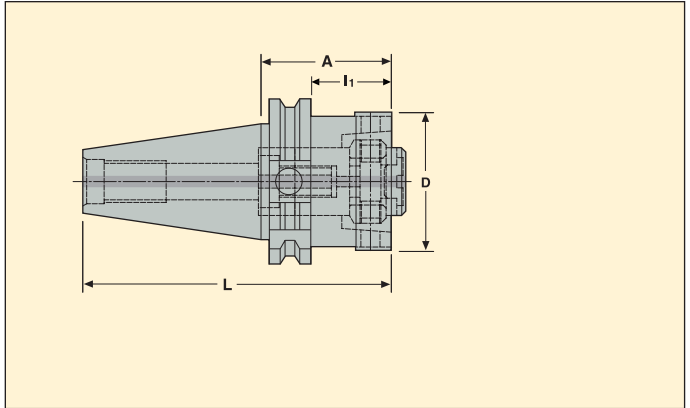

Taper	For HSK-A/C	Part No.	Dimensions in mm				Equipped with TF unit ref.	Balancing	
			A	D	L	I ₁			
DIN50 AD	HSK-A/C63	E447150956340	40	70	141,7	21	24H509563	2	2,96

Accessories

For	Key
HSK-A/C63	H05-4

Please check availability in current price and stock-list



- With expandable hydraulic spigot
- Direct run-out 5 µm maximum
- With coolant supply channels through the spigot

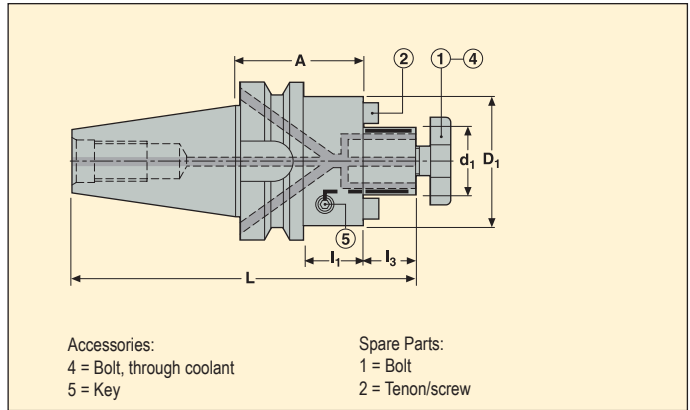

Taper	d ₁ mm	Part No.	Dimensions in mm					Balancing	
			A	D ₁	L	l ₁	l ₃		
BT40 ADB	22	E341455452245	45	48	129,4	18	19	1	1,21
	27	E341455452745	45	60	131,4	18	21	1	1,42
BT50 ADB	22	E341655452255	55	48	175,8	17	19	1	3,70
	27	E341655452755	55	60	177,8	17	21	1	3,86
	32	E341655453255	55	78	180,8	17	24	1	4,20
	40	E341655454055	55	89	183,8	17	27	1	4,52

Accessories

For d ₁	Bolt, through coolant	Key	Spanner
22	5802210L	H04-4	5812210
27	5802712L	H04-4	5812712
32	5803216L	H04-4	5813216
40	5804020L	H04-4	5814020

Spare Parts

For d ₁	Bolt	Screw	Tenon
22	5802210	951D0416	16C2101111
27	5802712	951D0508	16C2121214
32	5803216	951D0516	16C2141421
40	5804020	951D0516	16C2161621

Please check availability in current price and stock-list



- With dynamic damping, ready to use
- Direct run-out 5 µm maximum
- With coolant supply channels through the spigot

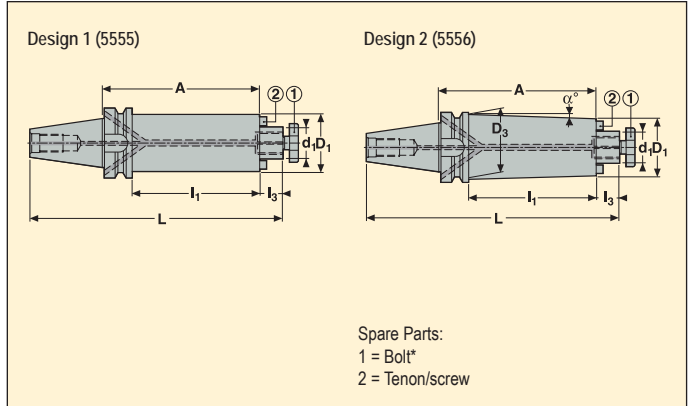

Taper	d ₁ mm	Part No.	Dimensions in mm						Design	α°	Balancing	KG
			A	D ₁	D ₃	L	I ₁	I ₃				
BT40 ADB	16	E3414555516160	160	38	–	242,4	133	17	1	–	2	2,23
	22	E3414555522210	210	48	–	294,4	183	19	1	–	2	3,78
	22	E3414555622260	260	48	60,0	344,4	233	19	2	1,3	2	5,40
	27	E3414555527260	260	60	–	346,4	233	21	1	–	2	6,86
BT50 ADB	22	E3416555522210	210	48	–	330,8	172	19	1	–	2	6,08
	22	E3416555622260	260	48	64,0	380,8	222	19	2	1,9	2	7,90
	27	E3416555527260	260	60	–	382,8	222	21	1	–	2	9,06
	27	E3416555627320	320	60	80,0	442,8	282	21	2	1,9	2	12,64
	32	E3416555532330	330	78	–	455,8	292	24	1	–	2	15,34
	40	E3416555540350	350	89	–	475,8	312	27	1	–	2	20,70

d₁ 40, includes 4 threaded holes on the bearing face according to DIN 6357

Accessories

For d ₁	Spanner
16	5811608
22	5812210
27	5812712
32	5813216
40	5814020

Spare Parts*

For d ₁	Bolt	Screw	Tenon
16	5801608	950D0312	16C2080810A
22	5802210	950D0416	16C2101111
27	5802712	950D0516	16C2121214A
32	5803216	950D0516	16C2141421A
40	5804020	950D0616	16C2161621A

Please check availability in current price and stock-list

* These centre bolts are similar to the original delivered ones: check if lengths L are suitable for the milling cutters used, therefore see instructions in catalogue's Guide pages or in the Operating instructions sheet delivered with the holders



- Direct run-out 5 µm maximum
- With coolant supply channels through the spigot

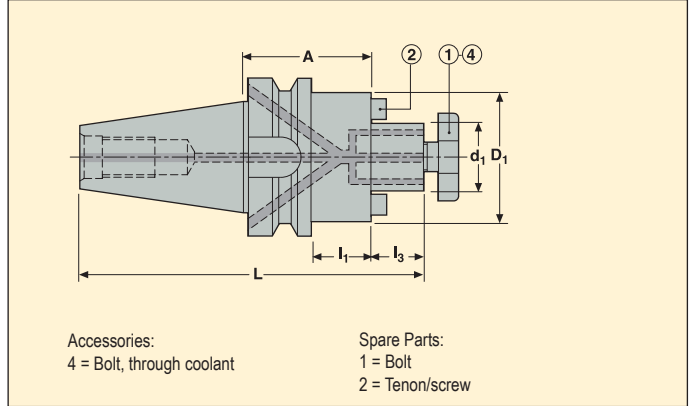

Taper	d ₁ mm	Part No.	Dimensions in mm					Balancing	KG
			A	D ₁	L	l ₁	l ₃		
BT40 ADB	16	E341455251645	45	38	127,4	18	17	2	1,13
	16	E3414552516100	100	38	182,4	73	17	2	1,56
	22	E341455252245	45	48	129,4	18	19	2	1,24
	22	E3414552522100	100	48	184,4	73	19	2	1,96
	27	E341455252745	45	60	131,4	18	21	2	1,42
	27	E3414552527100	100	60	186,4	73	21	2	2,58
	32	E341455253250	50	78	139,4	23	24	2	1,84
	40	E341455254050	50	89	142,4	23	27	2	2,09

d₁ 40, includes 4 threaded holes on the bearing face according to DIN 6357

Accessories

For d ₁	Bolt, through coolant	Spanner
16	5801608L	5811608
22	5802210L	5812210
27	5802712L	5812712
32	5803216L	5813216
40	5804020L	5814020

Spare Parts

For d ₁	Bolt	Screw	Tenon
16	5801608	950D0312	16C10810164
22	5802210	950D0416	16C11012206
27	5802712	951D0512	16C11214243
32	5803216	951D0516	16C2141421
40	5804020	951D0616	16C2161621

Please check availability in current price and stock-list



- Direct run-out 5 µm maximum
- With coolant supply channels through the spigot

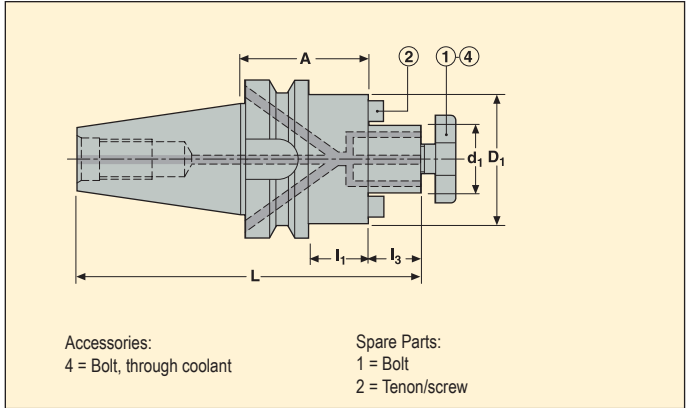

Taper	d ₁ mm	Part No.	Dimensions in mm					*	Balancing		
			A	D ₁	L	I ₁	I ₃				
BT50 ADB	16	E3416552516100	100	38	218,8	62	17		2	4,00	
	22	E3416552522100	100	48	220,8	62	19		2	4,28	
	22	E3416552522160	160	48	280,8	122	19		2	5,34	
	22	E341655252255	55	48	175,8	17	19		2	3,78	
	27	E341655252755	55	60	177,8	17	21	*	2	3,93	
	27	E3416552527100	100	60	222,8	62	21		2	4,80	
	27	E3416552527160	160	60	282,8	122	21		2	6,30	
	32	E3416552532100	100	78	225,8	62	24		2	5,88	
	32	E3416552532160	160	78	285,8	122	24		2	8,02	
	32	E341655253255	55	78	180,8	17	24		2	4,26	
	40	E3416552540100	100	89	228,8	62	27		2	6,58	
	40	E3416552540160	160	89	288,8	122	27		2	9,42	
	40	E341655254055	55	89	183,8	17	27		2	4,50	
		27	E341655242755	55	48	177,8	28	21	*	2	3,78

d₁ 40, includes 4 threaded holes on the bearing face according to DIN 6357

* Diameter D₁ on type 5524 is smaller than on type 5525

Accessories

For d ₁	Bolt, through coolant	Spanner
16	5801608L	5811608
22	5802210L	5812210
27/5524	5802712L	5812712
27/5525	5802712L	5812712
32	5803216L	5813216
40	5804020L	5814020

Spare Parts

For d ₁	Bolt	Screw	Tenon
16	5801608	950D0312	16C10810164
22	5802210	950D0416	16C11012206
27/5524	5802712	951D0512	16C127
27/5525	5802712	951D0512	16C11214243
32	5803216	951D0516	16C2141421
40	5804020	951D0616	16C2161621

Please check availability in current price and stock-list

EPB 552 – Shell mill holders, small face – ISO 3937

BT JIS B 6339-AD



- Direct run-out 5 µm maximum
- Small front face diameter D_1 according to ISO 3937, suitable for Seco disc mill cutters Type B

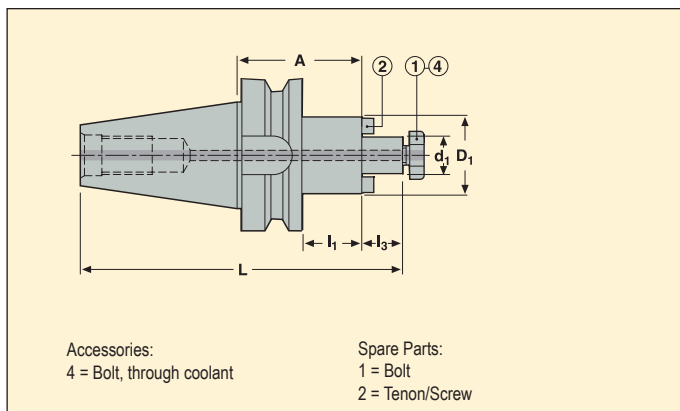

Taper	d_1 mm	Part No.	Dimensions in mm					Balancing	
			A	D_1	L	l_1	l_3		
BT30 AD	16	E40405521640	40	32	105,4	18	17	2	0,52
	22	E40405522240	40	40	107,4	18	19	2	0,62
	27	E40405522740	40	48	109,4	18	21	2	0,74
BT40 AD	16	E40415521652	52	32	134,4	25	17	2	1,12
	22	E40415522252	52	40	136,4	25	19	2	1,25
	27	E40415522752	52	48	138,4	25	21	2	1,40
	32	E40415523252	52	58	141,4	25	24	2	1,60
	40	E40415524060	60	70	152,4	33	27	2	2,28
BT50 AD	22	E57665522263	63	40	183,8	25	19	2	3,80
	27	E57665522763	63	48	185,8	25	21	2	3,96
	32	E57665523263	63	58	188,8	25	24	2	4,20
	40	E57665524063	63	70	191,8	25	27	2	4,56

Accessories

For d_1	Bolt, through coolant	Spanner
16	5801608L	5811608
22	5802210L	5812210
27	5802712L	5812712
32	5803216L	5813216
40	5804020L	5814020

Spare Parts

For d_1	Bolt	Screw	Tenon
16	5801608	950D0308	16C116
22	5802210	951D0410	16C122
27	5802712	951D0512	16C127
32	5803216	951D0514	16C132
40	5804020	951D0616	16C140

Please check availability in current price and stock-list



- Direct run-out 5 µm maximum

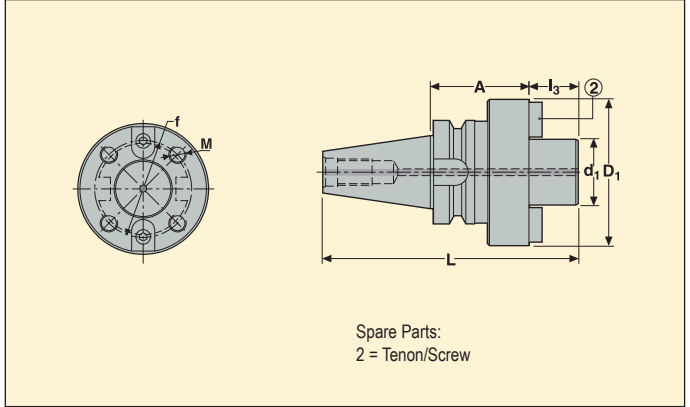

Taper	d ₁ mm	Part No.	Dimensions in mm					M mm	Balancing	
			A	D ₁	L	I ₃	f			
BT50 AD	40	E57665694070	70	89	201,8	30	66,7	M12	2	5,24
	60	E57665696080	80	129	221,8	40	101,6	M16	2	8,00

Spare Parts

For d ₁	Screw	Tenon
40	951D0616	16C34040
60	951D1225	16C35060

Please check availability in current price and stock-list

Monobloc holders BT JIS

EPB 5657 – Disc mill holders



- With adjustable slide rod
- Best suitable for Seco disc mill cutters Type A

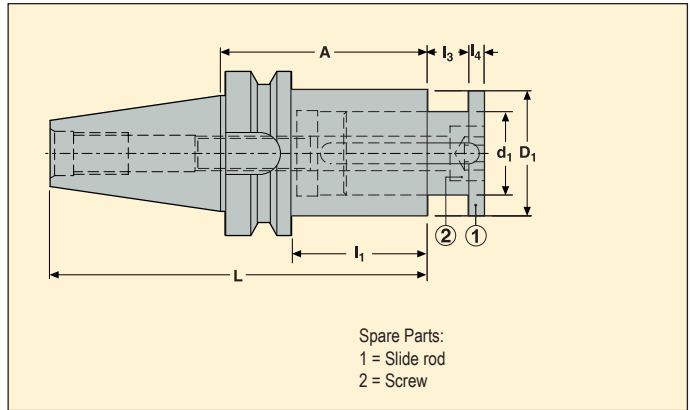

Taper	d ₁ mm	Part No.	Dimensions in mm						Balancing	
			A	D ₁	L	I ₁	I ₃	I ₄		
BT40 A	22	E404156572270	70	35	135,4	43	0-12	4	2	1,30
	27	E404156572775	75	42	140,4	48	0-15	5	2	1,52
	32	E404156573290	90	48	155,4	63	0-24	6	2	1,91
BT50 A	40	E5766565740120	120	58	221,8	82	0-30	7	2	5,34
	50	E5766565750145	145	72	246,8	107	0-32	8	2	7,04
	60	E5766565760180	180	90	281,8	142	0-40	8	2	10,74

Spare Parts

For d ₁	Screw	Slide rod
22		
27	19C565722	565722
27	19C565727	565727
32	950D1690	565732
40	19C565740	565740
50	19C565750	565750
60	19C565760	565760

Please check availability in current price and stock-list



- Direct run-out 3 μ m maximum
- Weldon d 16, 20, 25, 32 and 40 with ground face (Seco-Weldon compatible)

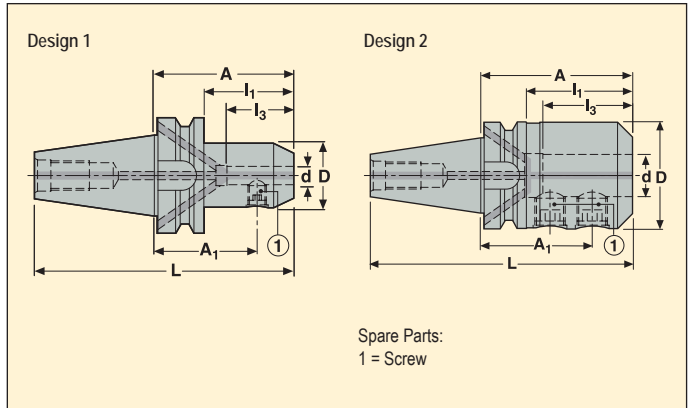

Taper	d mm	Part No.	Dimensions in mm						Design	Balancing	
			A	D	L	I ₁	I ₃	A ₁			
BT40 ADB	6	E34145840650	50	25	115,4	23	27	32,5	1	2	1,00
	6	E341458406120	120	25	185,4	93	27	102,5	1	2	1,30
	8	E34145840850	50	28	115,4	23	30	32,5	1	2	1,05
	10	E34145841063	63	35	128,4	36	36	43,5	1	2	1,20
	12	E34145841263	63	42	128,4	36	43	41,0	1	2	1,30
	12	E341458412120	120	42	185,4	93	43	98,0	1	2	1,85
	14	E34145841463	63	44	128,4	36	43	41,0	1	2	1,30
	16	E34145841663	63	48	128,4	36	46	39,5	1	2	1,35
	16	E341458416120	120	48	185,4	93	46	96,5	1	2	2,15
	18	E34145841863	63	50	128,4	36	46	39,5	1	2	1,40
	20	E34145842063	63	52	128,4	36	48	38,5	1	2	1,35
	20	E341458420120	120	52	185,4	93	48	95,5	1	2	2,30
	25	E34145842590	90	63	155,4	–	54	66,5	2	2	2,20
	32	E341458432100	100	72	165,4	–	58	76,5	2	2	2,70

Spare Parts

For d	Locking screw
6	951C0610
8	951C0810
10	951C1012
12-14	951C1216
16-18	951C1416
20	951C1616
25	951C1820
32	951C2020

Please check availability in current price and stock-list

Monobloc holders BT JIS

EPB 584 – Side lock holders, Weldon – DIN 1835 Form B/ DIN 6535 Form HB

BT JIS B 6339-ADB



- Direct run-out 3 µm maximum
- Weldon d 16, 20, 25, 32 and 40 with ground face (Seco-Weldon compatible)

Design 1

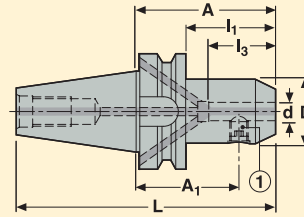

Design 2

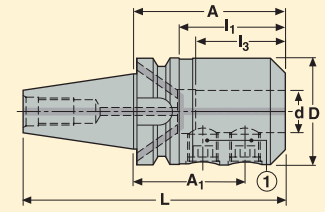

Spare Parts:
1 = Screw

Taper	d mm	Part No.	Dimensions in mm						Design	Balancing	
			A	D	L	I ₁	I ₃	A ₁			
BT50 ADB	10	E34165841063	63	35	164,8	25	36	43,5	1	2	3,60
	12	E34165841280	80	42	181,8	42	43	58,0	1	2	4,00
	14	E34165841480	80	44	181,8	42	43	58,0	1	2	4,00
	16	E34165841680	80	48	181,8	42	46	56,5	1	2	4,10
	16	E341658416120	120	48	221,8	82	46	96,5	1	2	4,60
	18	E34165841880	80	50	181,8	42	46	56,5	1	2	3,94

Spare Parts

For d	Locking screw
10	951C1012
12-14	951C1216
16-18	951C1416

Please check availability in current price and stock-list

Monobloc holders BT JIS



EPB 584 – Side lock holders, Weldon – DIN 1835 Form B/ DIN 6535 Form HB

BT JIS B 6339-ADB



- Direct run-out $3\ \mu\text{m}$ maximum
- Weldon d 16, 20, 25, 32 and 40 with ground face (Seco-Weldon compatible)

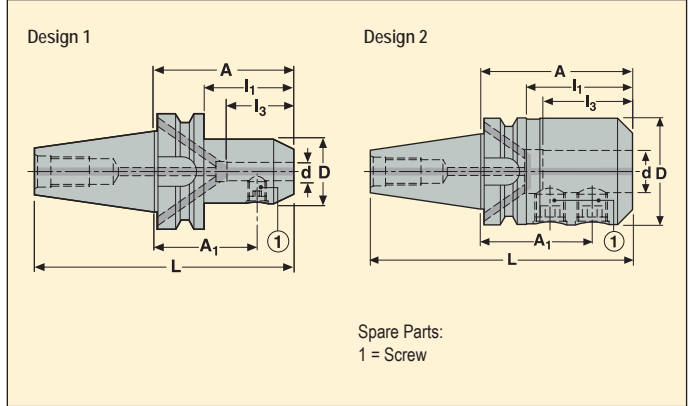

Taper	d mm	Part No.	Dimensions in mm						Design	Balancing	
			A	D	L	I ₁	I ₃	A ₁			
BT50 ADB	20	E34165842080	80	52	181,8	42	48	55,5	1	2	3,98
	20	E341658420120	120	52	221,8	82	48	95,5	1	2	4,75
	25	E341658425100	100	65	201,8	62	54	76,5	2	2	4,90
	25	E341658425120	120	65	221,8	82	54	96,5	2	2	5,12
	32	E341658432105	105	72	206,8	67	58	81,5	2	2	5,25
	40	E341658440120	120	80	221,8	82	68	90,5	2	2	6,00
	50	E341658450130	130	100	231,8	92	78	95,5	2	2	7,65

Spare Parts

For d	Locking screw
20	951C1616
25	951C1820
32-40	951C2020
50	951C2425

Please check availability in current price and stock-list



- Direct run-out 5 µm maximum
- Weldon d 16, 20, 25, 32 and 40 with ground face (Seco-Weldon compatible)

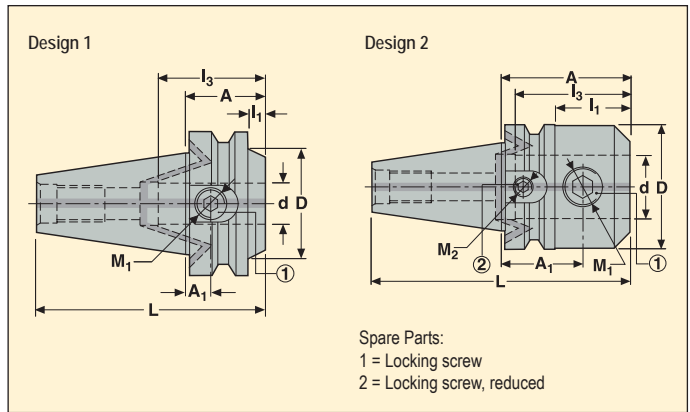

Taper	d mm	Part No.	Dimensions in mm						M ₁ mm	M ₂ mm	Design	Balancing	
			A	D	L	I ₁	I ₃	A ₁					
BT40 ADB	20	E341458422035	35	50	100,4	8	49	10,5	M16	–	1	2	0,95
	25	E341458422560	60	62	125,4	33	54	36,5	M18x2	M14	2	2	1,50
	32	E341458423265	65	62	130,4	38	58	41,5	M20x2	M10	2	2	1,45
BT50 ADB	20	E341658422044	44	48	145,8	6	48	19,5	M16	–	1	2	3,55
	25	E341658422544	44	57	145,8	6	54	20,5	M18x2	–	1	2	3,45
	32	E341658423260	60	72	161,8	22	58	36,5	M20x2	M14	2	2	3,80

Spare Parts

For d	Locking screw	Locking screw, reduced
20/E3414	951C1614	–
20/E3416	951C1616	–
25/E3414	951C1817	950A1412
25/E3416	951C1820	–
32/E3414	951C2014	950A1008
32/E3416	951C2020	950A1416

Please check availability in current price and stock-list

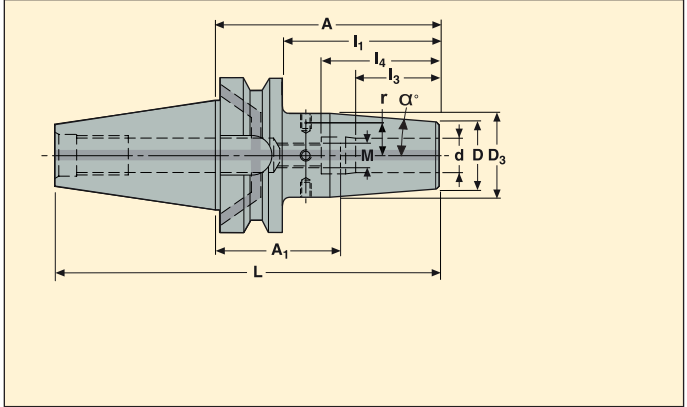

- Run-out 3 μm at 3x d (direct run-out 3 μm) maximum
- Delivered with one stop screw

Taper	d mm	Part No.	Dimensions in mm								M mm	α°	r mm	Balancing	KG
			A	D	D ₃	L	I ₁	I ₃	I ₄	A ₁ min-max					
BT30 AD	6	E404056030680	80	21	27	128,4	58	22	37,5	44-54	M5	4,5	10,5	1	0,60
	8	E404056030880	80	21	27	128,4	58	26	37,5	44-54	M6	4,5	10,5	1	0,60
	10	E404056031080	80	24	32	128,4	58	31	42,5	39-49	M8x1	4,5	13,0	1	0,70
	12	E404056031280	80	24	32	128,4	58	34	47,5	34-44	M10x1	4,5	13,0	1	0,70

For Shrinkfit extensions, see page(s) 294

Accessories

For d	Balancing screws
6	90ZQ01
8	90ZQ01
10	90ZQ01
12	90ZQ01

Spare Parts

For d	Stop screw
6	19BDR05165
8	19BDR06165
10	19BDR08165
12	19BDR10165

Please check availability in current price and stock-list
 For stop screw setting adapters, see page(s) 336

EPB 5603 – Shrinkfit holders, DIN type

BT JIS B 6339-ADB



- Run-out 3 μm at 3xd (direct run-out 3 μm) maximum
- Delivered with one stop screw

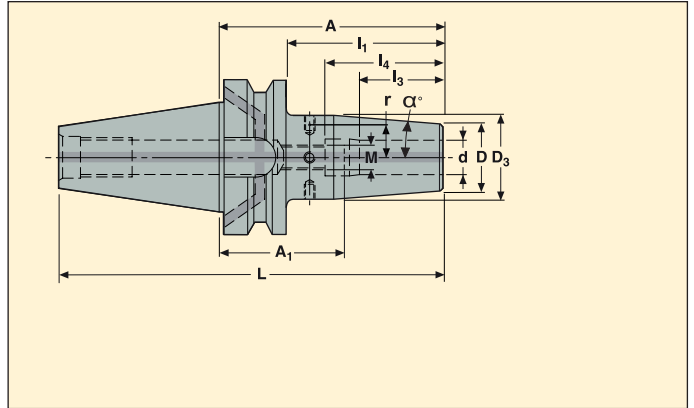

Taper	d mm	Part No.	Dimensions in mm								M mm	α°	r mm	Balancing	KG
			A	D	D ₃	L	I ₁	I ₃	I ₄	A ₁ min-max					
BT40 ADB	6	E341456030690	90	21	27	155,4	63	22	37,5	54-64	M5	4,5	10,5	1	1,18
	6	E3414560306120	120	21	27	185,4	93	22	37,5	84-94	M5	4,5	10,5	1	1,31
	6	E3414560306160	160	21	27	225,4	133	22	37,5	124-134	M5	4,5	10,5	1	1,45
	8	E341456030890	90	21	27	155,4	63	26	37,5	54-64	M6	4,5	10,5	1	1,18
	8	E3414560308120	120	21	27	185,4	93	26	37,5	84-94	M6	4,5	10,5	1	1,30
	8	E3414560308160	160	21	27	225,4	133	26	37,5	124-134	M6	4,5	10,5	1	1,44
	10	E341456031090	90	24	32	155,4	63	31	42,5	46-59	M8x1	4,5	13,0	1	1,23
	10	E3414560310120	120	24	32	185,4	93	31	42,5	79-89	M8x1	4,5	13,0	1	1,50
	10	E3414560310160	160	24	32	225,4	133	31	42,5	119-129	M8x1	4,5	13,0	1	1,70

For Shrinkfit extensions, see page(s) 294

Accessories

For d	Balancing screws
6	90ZQ01
8	90ZQ01
10	90ZQ01

Spare Parts

For d	Stop screw
6	19BDR05165
8	19BDR06165
10	19BDR08165

Please check availability in current price and stock-list
For stop screw setting adapters, see page(s) 336



- Run-out 3 µm at 3xd (direct run-out 3 µm) maximum
- Delivered with one stop screw

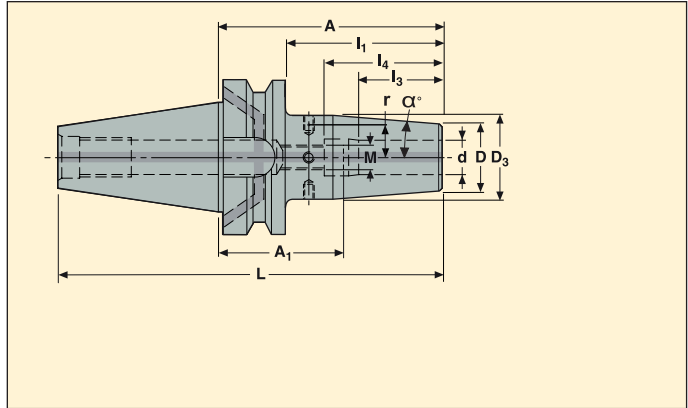

Taper	d mm	Part No.	Dimensions in mm								M mm	α°	r mm	Balancing	KG
			A	D	D ₃	L	I ₁	I ₃	I ₄	A ₁ min-max					
BT40 ADB	12	E341456031290	90	24	32	155,4	63	34	47,5	44-54	M10x1	4,5	13,0	1	1,21
	12	E3414560312120	120	24	32	185,4	93	34	47,5	74-84	M10x1	4,5	13,0	1	1,39
	12	E3414560312160	160	24	32	225,4	133	34	47,5	114-124	M10x1	4,5	13,0	1	1,70
	14	E341456031490	90	27	34	155,4	63	34	47,5	44-54	M10x1	4,5	14,0	1	1,35
	14	E3414560314120	120	27	34	185,4	93	34	47,5	74-84	M10x1	4,5	14,0	1	1,50
	16	E341456031690	90	27	34	155,4	63	39	50,5	41-51	M12x1	4,5	14,0	1	1,24
	16	E3414560316120	120	27	34	185,4	93	39	50,5	71-81	M12x1	4,5	14,0	1	1,50
	16	E3414560316160	160	27	34	225,4	133	39	50,5	111-121	M12x1	4,5	14,0	1	1,70
	18	E341456031890	90	33	42	155,4	63	39	50,5	41-51	M12x1	4,5	18,0	1	1,40
	20	E341456032090	90	33	42	155,4	63	41	52,5	39-49	M16x1	4,5	18,0	1	1,34
	20	E3414560320120	120	33	42	185,4	93	41	52,5	69-79	M16x1	4,5	18,0	1	1,70
	25	E3414560325100	100	44	53	165,4	73	47	58,5	43-53	M16x1	4,5	23,5	1	1,78

For Shrinkfit extensions, see page(s) 294

Accessories

For d	Balancing screws
12-14	90ZQ01
16-18	90ZQ01
20-25	90ZQ01

Spare Parts

For d	Stop screw
12-14	19BDR10165
16-18	19BDR12165
20-25	19BDR16165

Please check availability in current price and stock-list
For stop screw setting adapters, see page(s) 336

Monobloc holders BT JIS

EPB 5603 – Shrinkfit holders, DIN type

BT JIS B 6339-ADB



- Run-out 3 µm at 3xd (direct run-out 3 µm) maximum
- Delivered with one stop screw

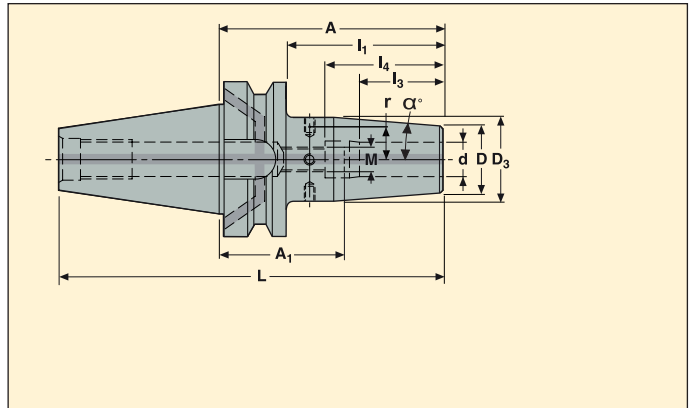

Taper	d mm	Part No.	Dimensions in mm								M mm	α°	r mm	Balancing	KG
			A	D	D ₃	L	I ₁	I ₃	I ₄	A ₁ min-max					
BT50 ADB	6	E3416560306100	100	21	27	201,8	62	22	37,5	64-74	M5	4,5	10,5	1	3,76
	6	E3416560306160	160	21	27	261,8	122	22	37,5	124-134	M5	4,5	10,5	1	3,98
	8	E3416560308100	100	21	27	201,8	62	26	37,5	64-74	M6	4,5	10,5	1	3,80
	8	E3416560308160	160	21	27	261,8	122	26	37,5	124-134	M6	4,5	10,5	1	4,00
	10	E3416560310100	100	24	32	201,8	62	31	42,5	59-69	M8x1	4,5	13,0	1	3,81
	10	E3416560310160	160	24	32	261,8	122	31	42,5	119-129	M8x1	4,5	13,0	1	4,15
	12	E3416560312100	100	24	32	201,8	62	34	47,5	54-64	M10x1	4,5	13,0	1	3,80
	12	E3416560312160	160	24	32	261,8	122	34	47,5	114-124	M10x1	4,5	13,0	1	4,14
	14	E3416560314100	100	27	34	201,8	62	34	47,5	54-64	M10x1	4,5	14,0	1	3,85
	16	E3416560316100	100	27	34	201,8	62	39	50,5	51-61	M12x1	4,5	14,0	1	3,82
	16	E3416560316160	160	27	34	261,8	122	39	50,5	111-121	M12x1	4,5	14,0	1	4,20
	18	E3416560318100	100	33	42	201,8	62	39	50,5	51-61	M12x1	4,5	18,0	1	3,95
	20	E3416560320100	100	33	42	201,8	62	41	52,5	49-59	M16x1	4,5	18,0	1	3,90
	20	E3416560320160	160	33	42	261,8	122	41	52,5	109-119	M16x1	4,5	18,0	1	4,49
	25	E3416560325110	110	44	53	211,8	72	47	58,5	53-63	M16x1	4,5	23,5	1	4,35
	25	E3416560325160	160	44	53	261,8	122	47	58,5	103-113	M16x1	4,5	23,5	1	5,20
	32	E3416560332110	110	44	53	211,8	72	51	62,5	49-59	M16x1	4,5	23,5	1	4,20

For Shrinkfit extensions, see page(s) 294

Accessories

For d	Balancing screws
6	90ZQ01
8	90ZQ01
10	90ZQ01
12-14	90ZQ01
16-18	90ZQ01
20-32	90ZQ01

Spare Parts

For d	Stop screw
6	19BDR05165
8	19BDR06165
10	19BDR08165
12-14	19BDR10165
16-18	19BDR12165
20-32	19BDR16165

Please check availability in current price and stock-list

For stop screw setting adapters, see page(s) 336



- Reinforced design with wider front and tapered body
- Run-out 3 µm maximum at 3xd
- With coolant supply channels towards the tool (plugged)

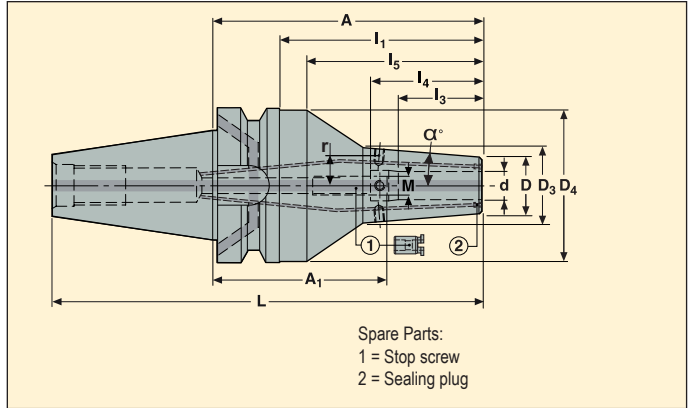

Taper	d mm	Part No.	Dimensions in mm											M mm	α°	r mm	Balancing	KG
			A*	D	D ₃	D ₄	L	I ₁	I ₃	I ₄	I ₅	A ₁ min-max						
BT40 ADB	6	E3414560006130	130	24	32,2	61,5	195,4	103	22	37,5	95	94-104	M5	4,5	12,0	1	2,00	
	8	E3414560008130	130	24	32,2	61,5	195,4	103	26	37,5	95	94-104	M6	4,5	12,0	1	2,00	
	10	E341456001070	70	27	33,8	–	135,4	43	31	42,5	–	29-39	M8x1	4,5	13,5	1	1,20	
	10	E3414560010130	130	27	35,2	61,5	195,4	103	31	42,5	95	89-99	M8x1	4,5	13,5	1	2,05	
	12	E341456001270	70	27	33,8	–	135,4	43	34	47,5	–	24-34	M10x1	4,5	13,5	1	1,20	
	12	E3414560012130	130	27	35,2	61,5	195,4	103	34	47,5	95	84-94	M10x1	4,5	13,5	1	2,05	
	16	E341456001675	75	33	40,6	–	140,4	48	39	50,5	–	26-36	M12x1	4,5	17,0	1	1,30	
	16	E3414560016130	130	33	42,2	61,5	195,4	103	39	50,5	95	81-91	M12x1	4,5	17,0	1	2,15	
	20	E341456002075	75	44	51,6	–	140,4	48	41	52,5	–	24-34	M16x1	4,5	21,5	1	1,47	
	20	E3414560020130	130	44	53,1	61,5	195,4	103	41	52,5	95	79-89	M16x1	4,5	21,5	1	2,53	
	25	E341456002585	85	48	59,1	–	150,4	58	47	58,5	–	28-38	M16x1	4,5	25,0	1	1,75	
	25	E3414560025130	130	48	63,0	61,5	195,4	103	51	58,5	95	73-83	M16x1	4,5	25,0	1	2,76	

* A = 70, 75 or 85: Extra-short holders requiring a dedicated Easyshrink® cooling contact bush type "5600 extra short", see page(s) 337

Accessories

For d	Balancing screws
6	90ZQ01
8	90ZQ01
10	90ZQ01
12	90ZQ01
16	90ZQ01
20-25	90ZQ01

Spare Parts

For d	Sealing plugs	Stop screw
6	90AI03	19BDR05165
8	90AI03	19BDR06165
10	90AI03	19BDR08165
12	90AI03	19BDR10165
16	90AI03	19BDR12165
20-25	90AI04	19BDR16165

Please check availability in current price and stock-list
For stop screw setting adapters, see page(s) 336



- Reinforced design with wider front and tapered body
- Run-out 3 μm maximum at 3xd
- With coolant supply channels towards the tool (plugged)

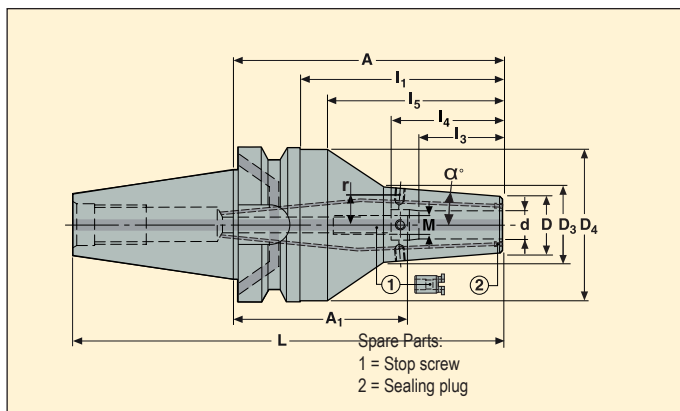

Taper	d mm	Part No.	Dimensions in mm										M mm	α°	r mm	Balancing	KG
			A°	D	D ₃	D ₄	L	I ₁	I ₃	I ₄	I ₅	A ₁ min-max					
BT50 ADB	6	E3416560006160	160	24	32,2	97,5	261,8	122	22	37,5	110	124-134	M5	4,5	12,0	1	6,15
	8	E3416560008160	160	24	32,2	97,5	261,8	122	26	37,5	110	124-134	M6	4,5	12,0	1	6,10
	10	E3416560010100	100	27	36,8	–	201,8	62	31	42,5	–	59-69	M8x1	4,5	13,5	1	4,00
	10	E3416560010160	160	27	35,2	97,5	261,8	122	31	42,5	110	119-129	M8x1	4,5	13,5	1	6,20
	10	E3416560010200	200	27	25,2	97,5	301,8	162	31	42,5	150	159-169	M8x1	4,5	13,5	1	7,35
	12	E3416560012100	100	27	36,8	–	201,8	62	34	47,5	–	54-64	M10x1	4,5	13,5	1	3,95
	12	E3416560012160	160	27	35,2	97,5	261,8	122	34	47,5	110	114-124	M10x1	4,5	13,5	1	6,20
	12	E3416560012200	200	27	35,2	97,5	301,8	162	34	47,5	150	154-164	M10x1	4,5	13,5	1	7,35
	16	E3416560016100	100	33	42,8	–	201,8	62	39	50,5	–	51-61	M12x1	4,5	17,0	1	4,05
	16	E3416560016160	160	33	42,2	97,5	261,8	122	39	50,5	110	111-121	M12x1	4,5	17,0	1	6,30
	16	E3416560016200	200	33	42,2	97,5	301,8	162	39	50,5	150	151-161	M12x1	4,5	17,0	1	7,55
	20	E3416560020100	100	44	53,8	–	201,8	62	41	52,5	–	49-59	M16x1	4,5	21,5	1	4,33
	20	E3416560020160	160	44	53,1	97,5	261,8	122	41	52,5	110	109-119	M16x1	4,5	21,5	1	6,76
	20	E3416560020200	200	44	53,1	97,5	301,8	162	41	52,5	150	149-159	M16x1	4,5	21,5	1	8,15
	25	E3416560025100	100	48	59,8	–	201,8	62	47	58,5	–	43-53	M16x1	4,5	25,0	1	4,46
	25	E3416560025160	160	48	59,1	97,5	261,8	122	47	58,5	110	113-103	M16x1	4,5	25,0	1	7,00
	25	E3416560025200	200	48	59,1	97,5	301,8	162	47	58,5	150	153-143	M16x1	4,5	25,0	1	8,50
	32	E3416560032105	105	48	60,6	–	206,8	67	51	62,5	–	44-54	M16x1	4,5	25,0	1	4,40
	32	E3416560032160	160	48	59,1	97,5	261,8	122	51	62,5	110	99-109	M16x1	4,5	25,0	1	6,83
	32	E3416560032200	200	48	59,1	97,5	301,8	162	51	62,5	150	139-149	M16x1	4,5	25,0	1	8,33

* E3416560025100 and E3416560032105: Extra-short holders requiring a dedicated Easyshrink® cooling contact bush type "5600 extra short", see page(s) 337

Accessories

For d	Balancing screws
6	90ZQ01
8	90ZQ01
10	90ZQ01
12	90ZQ01
16	90ZQ01
20-32	90ZQ01

Spare Parts

For d	Sealing plugs	Stop screw
6	90AI03	19BDR05165
8	90AI03	19BDR06165
10	90AI03	19BDR08165
12	90AI03	19BDR10165
16	90AI03	19BDR12165
20-32	90AI04	19BDR16165

Please check availability in current price and stock-list
For stop screw setting adapters, see page(s) 336



- Reinforced design with wider front and tapered body
- Run-out 3 µm maximum at 3xd
- With coolant supply channels towards the tool (plugged)

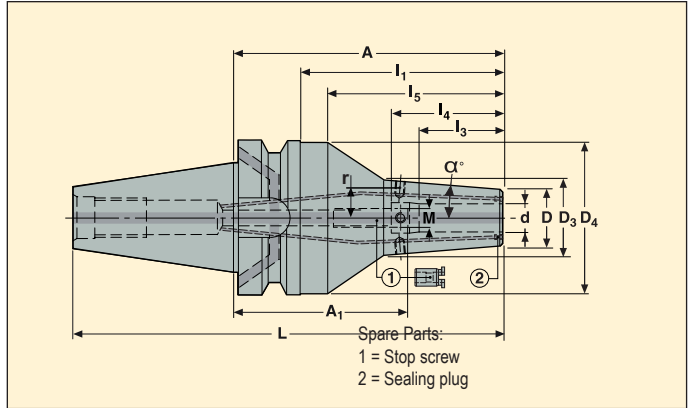

Taper	d mm	Part No.	Dimensions in mm								M mm	α°	r mm	Balancing	KG
			A**	D	D ₃	L	I ₁	I ₃	I ₄	A ₁ min-max					
BT40 TF ADB	12	E321456001270	70	27	33,8	135,4	43	34	47,5	24-34	M10x1	4,5	13,5	1	1,20
	16	E321456001675	75	33	40,6	140,4	48	39	50,5	26-36	M12x1	4,5	17,0	1	1,30
	20	E321456002075	75	44	51,6	140,4	48	41	52,5	24-34	M16x1	4,5	21,5	1	1,60
	25	E321456002585	85	48	59,1	150,4	58	47	58,5	28-38	M16x1	4,5	25,0	1	1,70
BT50 TF ADB	12	E3216560012100	100	27	36,8	201,8	62	34	47,5	54-64	M10x1	4,5	13,5	1	4,10
	16	E3216560016100	100	33	42,8	201,8	62	39	50,5	51-61	M12x1	4,5	17,0	1	4,20
	20	E3216560020100	100	44	53,8	201,8	62	41	52,5	49-59	M16x1	4,5	21,5	1	4,50
	25	E3216560025100	100	48	57,8	201,8	62	47	58,5	43-53	M16x1	4,5	25,0	1	4,50
	32	E3216560032105	105	48	58,5	206,8	67	51	62,5	44-54	M16x1	4,5	25,0	1	4,50

** E321456001270, E321456001675, E321456002075, E321456002585, E3216560025100 and E3216560032105 : Extra-short holder requiring a dedicated Easy-shrink® cooling contact bush type "5600 extra short", see page(s) 337

Accessories

For d	Balancing screws
12	90ZQ01
16	90ZQ01
20-32	90ZQ01

Spare Parts

For d	Sealing plugs	Stop screw
12	90AI03	19BDR06165
16	90AI03	19BDR12165
20-32	90AI04	19BDR16165

Please check availability in current price and stock-list * Taper-Face (TF) holders have a larger flange towards machine side, with tight tolerances: They achieve taper and face contacts on machine spindles with Taper-Face dimensions. They are also usable on standard spindles, however a gap remains between spindle and flange faces. For stop screw setting adapters, see page(s) 336



- With Safe-Lock™ tool pull-out protection system
- Reinforced design of EPB 5600
- Run-out 3 μm maximum at 3xd
- With coolant supply channels towards the tool (plugged)

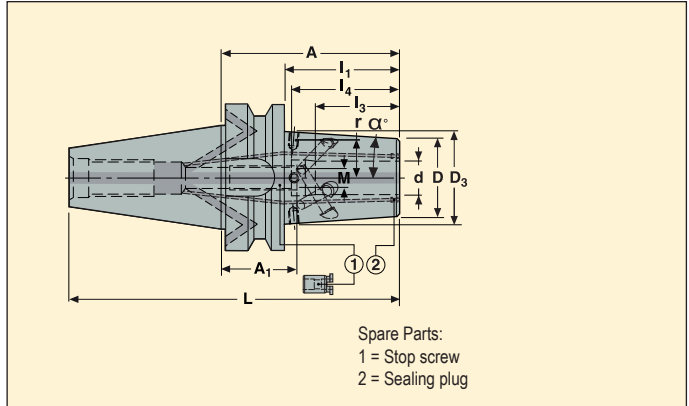

Taper	d mm	Part No.	Dimensions in mm								M mm	α°	r mm	Balancing	
			A*	D	D ₃	L	I ₁	I ₃	I ₄	A ₁ min-max					
BT40 ADB	12	E341456001270P	70	27	33,8	135,4	43	34	47,5	24-32,5	M10x1	4,5	13,5	1	1,20
	16	E341456001675P	75	33	40,6	140,4	48	39	50,5	26-34	M12x1	4,5	17,0	1	1,30
	20	E341456002075P	75	44	51,6	140,4	48	41	52,5	24-32	M16x1	4,5	21,5	1	1,50
	25	E341456002585P	85	50	59,1	150,4	58	47	58,5	28-36	M16x1	4,5	25,0	1	1,80
BT50 ADB	12	E3416560012100P	100	27	36,8	201,8	62	34	47,5	54-62,5	M10x1	4,5	13,5	1	4,00
	16	E3416560016100P	100	33	42,8	201,8	62	39	50,5	51-59	M12x1	4,5	17,0	1	4,10
	20	E3416560020100P	100	44	53,8	201,8	62	41	52,5	49-57	M16x1	4,5	21,5	1	4,40
	25	E3416560025100P	100	48	59,8	201,8	62	47	58,5	53-41	M16x1	4,5	25,0	1	4,50
	32	E3416560032105P	105	48	60,6	206,8	67	51	62,5	44-54	M16x1	4,5	25,0	1	4,40

* E341456001270P, E341456001675P, E341456002075P, E341456002585P, E3416560025100P and E3416560032105P: Extra-short holder requiring a dedicated Easyshrink® cooling contact bush type "5600 extra short", see page(s) 337

Accessories

For d	Balancing screws
12	90ZQ01
16	90ZQ01
20-32	90ZQ01

Spare Parts

For d	Sealing plugs	Stop screw
12	90AI03	-
16	90AI03	-
20-32	90AI04	19BDR16165

Please check availability in current price and stock-list
 (-) For d 12 and 16 mm, stop screw not removable/replaceable by the user, please request a repair process

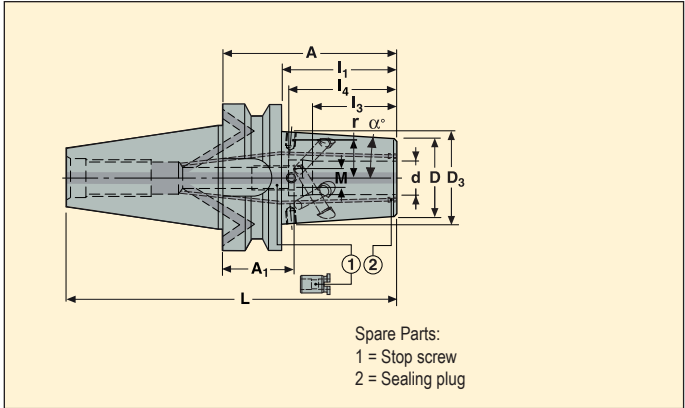

- With Safe-Lock™ tool pull-out protection system
- Reinforced design of EPB 5600
- Run-out 3 μm maximum at 3xd
- With coolant supply channels towards the tool (plugged)

Taper	d mm	Part No.	Dimensions in mm								M mm	α°	r mm	Balancing	KG
			A**	D	D ₃	L	I ₁	I ₃	I ₄	A ₁ min-max					
BT40 TF ADB	12	E321456001270P	70	27	33,8	135,4	43	34	47,5	24-32,5	M10x1	4,5	13,5	1	1,20
	16	E321456001675P	75	33	40,6	140,4	48	39	50,5	26-34	M12x1	4,5	17,0	1	1,30
	20	E321456002075P	75	44	51,6	140,4	48	41	52,5	24-32	M16x1	4,5	21,5	1	1,60
	25	E321456002585P	85	48	59,1	150,4	58	47	58,5	28-36	M16x1	4,5	25,0	1	1,70
BT50 TF ADB	12	E3216560012100P	100	27	36,8	201,8	62	34	47,5	54-62,5	M10x1	4,5	13,5	1	4,10
	16	E3216560016100P	100	33	42,8	201,8	62	39	50,5	51-59	M12x1	4,5	17,0	1	4,20
	20	E3216560020100P	100	44	53,8	201,8	62	41	52,5	49-57	M16x1	4,5	21,5	1	4,50
	25	E3216560025100P	100	48	57,8	201,8	62	47	58,5	43-51	M16x1	4,5	25,0	1	4,50
	32	E3216560032105P	105	48	58,5	206,8	67	51	62,5	44-54	M16x1	4,5	25,0	1	4,50

** A = 70 or 75: Extra-short holders requiring a dedicated Easyshrink® cooling contact bush type "5600 extra short", see page(s) 337

Accessories

For d	Balancing screws
12	90ZQ01
16	90ZQ01
20-32	90ZQ01

Spare Parts

For d	Sealing plugs	Stop screw
12	90AI03	-
16	90AI03	-
20-32	90AI04	19BDR16165

Please check availability in current price and stock-list * Taper-Face (TF) holders have a larger flange towards machine side, with tight tolerances: They achieve taper and face contacts on machine spindles with Taper-Face dimensions. They are also usable on standard spindles, however a gap remains between spindle and flange faces. (-) For d 12 and 16 mm, stop screw not removable/replaceable by the user, please request a repair process



• Run-out 3 µm at 3xd (direct run-out 3µm) maximum

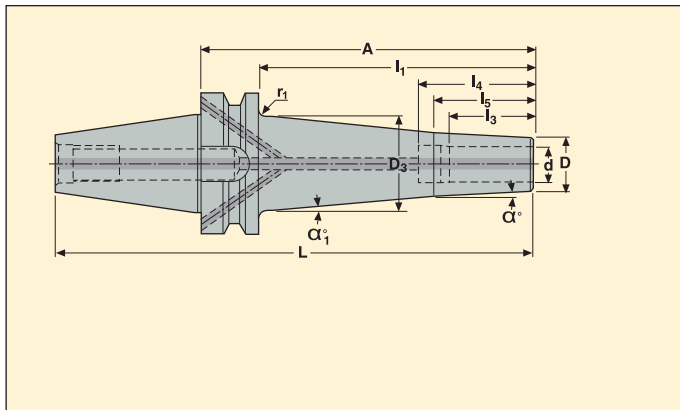
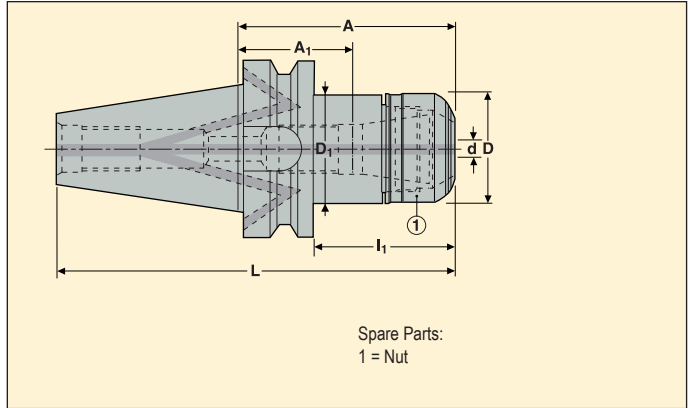

Table with columns: Taper, d mm, Part No., Dimensions in mm (A, D, D3, L, I1, I3, I4, I5), alpha°, alpha1°, r1 mm, Balancing, KG. Contains 12 rows of data for BT40 ADB.

Please check availability in current price and stock-list For Shrinkfit extensions, see page(s) 294



- Run-out 3 µm maximum at 3xd
- High transmittable torque
- High RPM suitable



Taper	Capacity d mm	Part No.	Chuck & Collet Size	Dimensions in mm						Balancing	
				A	D	D ₁	L	I ₁	A ₁ min-max*		
BT30 AD	1-7	E404056721150	HP 11	50	16	16	98,4	28	6-32	1	0,5
BT40 ADB	1-10	E341456721670	HP 16	70	30	30	135,4	43	25-40	1	1,12
	1-10	E3414567216160	HP 16	160	30	30	225,4	133	115-130	1	1,55
	2-16	E341456722570	HP 25	70	40	40	135,4	43	16-32	1	1,19
	2-16	E3414567225160	HP 25	160	40	40	225,4	133	95-122	1	1,96
	2-20	E341456723270	HP 32	70	50	50	135,4	43	15-22	1	1,29
BT50 ADB	2-16	E3416567225100	HP 25	100	40	40	201,8	62	35-62	1	3,93
	2-20	E3416567232100	HP 32	100	50	50	201,8	62	36-52	1	4,12

For ER HP collets type 5672, see page(s) 297-300

* A1 setting length onto stop screw when possible, or total available setting length for chucks without thread for stop end screw.

Accessories**

For size	Socket	Spanner	Stop screw	Torque key
HP 11	03EF567211	03B567211	19B5870812	03DYD010100
HP 16	03EF567216	03B567216	19B58711	03DYD010100
HP 25	03EF567225	03B567225	19B58718	03DYD020200
HP 32	03EF567232	03B567232	19B58722	03DYD020200

Spare Parts

For size	Nut
HP 11	08B567211
HP 16	08B567216
HP 25	08B567225
HP 32	08B567232

Please check availability in current price and stock-list

** When using a stop screw, its tapered contact onto the tool shank can increase the tool run-out defect. For tightening torques, see Guide pages



• Run-out 4 μ m maximum at 3xd

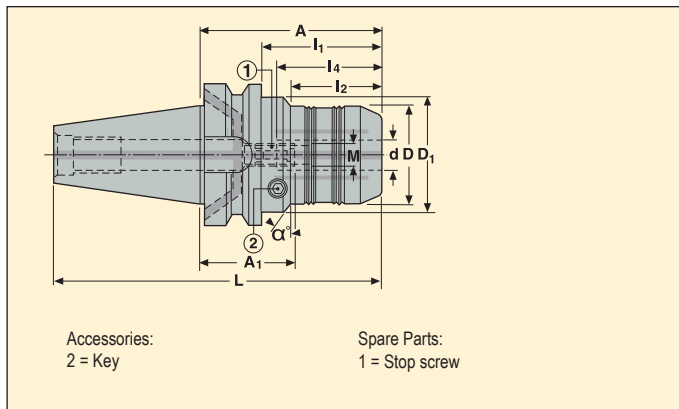

Taper	d mm	Part No.	Dimensions in mm								M mm	α [°]	Balancing	
			A	D	D ₁	L	I ₁	I ₂	I ₄	A ₁ min-max				
BT40 ADB	12	E341458351275	75	48,0	52,5	140,4	48	38	47	28-38	M10	30	1	1,56
	20	E341458352085	85	62,5	–	150,4	58	–	52	33-43	M10	–	1	2,20
BT50 ADB	12	E341658351275	75	48,0	–	176,8	37	–	47	28-38	M10	–	1	3,97
	20	E341658352085	85	62,5	–	186,8	47	–	52	33-43	M10	–	1	4,70
	32	E341658353290	90	80,0	–	191,8	52	–	63	27-37	M10	–	1	5,30

For reduction sleeves and control gauges, see page(s) 295-296

Accessories

For d	Locking key
12	03HXL06
20	03HXL06
32	03HXL06

Spare Parts

For d	Stop screw
12	19LS1016A
20	19LS1016A
32	19LS1016A

Please check availability in current price and stock-list



- Run-out 3 μm maximum at 3x ϕ

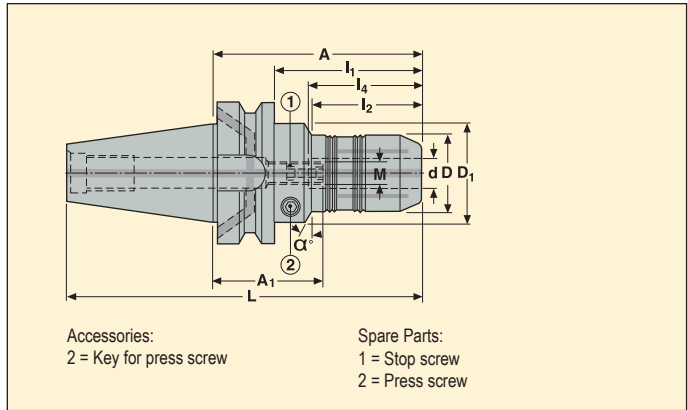

Taper	d mm	Part No.	Dimensions in mm								M mm	α°	Balancing	
			A	D	D ₁	L	I ₁	I ₂	I ₄	A ₁ min-max				
BT40 ADB	6	E341458340690	90	26	50	155,4	63	23	38	52-62	M5	30	1	1,55
	8	E341458340890	90	28	50	155,4	63	24	38	52-62	M5	30	1	1,55
	10	E341458341090	90	30	50	155,4	63	34	42	48-58	M8	30	1	1,47
	12	E341458341290	90	32	50	155,4	63	40	47	43-53	M10	30	1	1,42
	14	E341458341490	90	34	50	155,4	63	40	47	43-53	M10	30	1	1,45
	16	E341458341690	90	38	50	155,4	63	46	50	40-50	M10	30	1	1,50
	20	E341458342090	90	42	50	155,4	63	47	52	48-58	M10	30	1	1,50
25	E3414583425105	105	58	70	170,4	78	50	58	47-57	M10	45	1	2,30	
BT50 ADB	12	E3416583412105	105	32	50	206,8	67	40	47	58-68	M10	30	1	3,98
	20	E3416583420105	105	42	50	206,8	67	47	52	53-63	M10	30	1	4,04
	25	E3416583425110	110	58	70	211,8	72	50	58	52-62	M10	30	1	4,78
	32	E3416583432115	115	64	70	216,8	77	50	63	52-62	M10	30	1	4,99

For reduction sleeves, see page(s) 295 and control gauges, see page(s) 296

Accessories

For d	Locking key
6-8	H04-4
10	H04-4
12	H04-4
14-32	H04-4

Spare Parts

For d	Press screw	Stop screw
6-8	950AF0810008	19LS0520A
10	950AF0810008	19LS0820A
12	950AF0810008	19LS1020A
14-32	950AF1010010	19LS1020A

Please check availability in current price and stock-list

EPB 5675 – ER collet chucks – ISO 15488

BT JIS B 6339-AD



• Run-out 10 µm maximum at 3xd

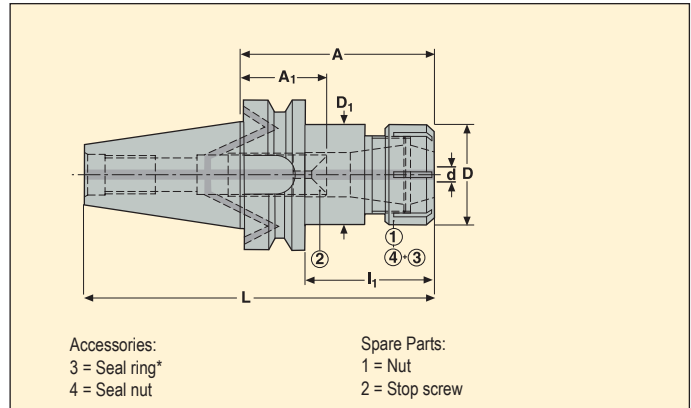

Taper	Capacity d mm	Part No.	Chuck & Collet Size	Dimensions in mm						Balancing	
				A	D	D ₁	L	I ₁	A ₁ min-max		
BT30 AD	0,5-10	E404056751660	ER 16	60	32	32	108,4	40	15-30	1	0,51
	1-16	E404056752565	ER 25	65	42	42	113,4	45	0-27	1	0,6

For ER collets, see page(s) 302-303, ER extensions, see page(s) 301

Accessories*

For size	Seal nut	Spanner
ER 16	08B587516IC	03B587516
ER 25	08B587525IC	03B587525

Spare Parts

For size	Nut	Stop screw
ER 16	08B587516X	19B58711
ER 25	08B587525X	19B58718

Please check availability in current price and stock-list

* For ER sealing rings, see page(s) 304



- Run-out 10 µm maximum at 3xd

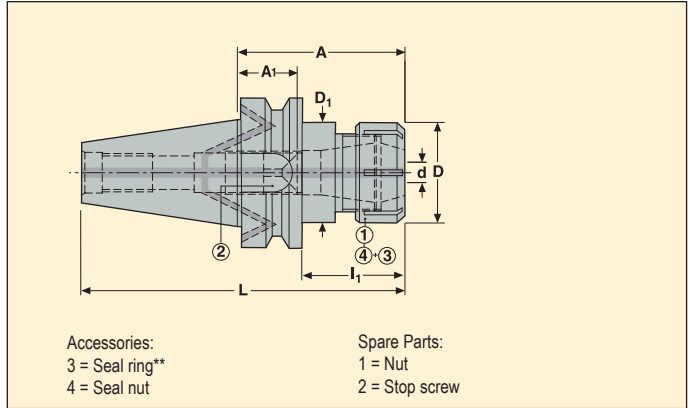

Taper	Capacity d mm	Part No.	Chuck & Collet Size	Dimensions in mm						A ₁ min-max	*	Balancing	
				A	D	D ₁	L	I ₁					
BT40 ADB	0,5-10	E341456751670	ER 16	70	32	32	135,4	43	25-40		1	1,12	
	0,5-10	E3414567516120	ER 16	120	32	32	185,4	93	75-90		1	1,39	
	1-16	E341456752570	ER 25	70	42	42	135,4	43	2-32		1	1,18	
	1-16	E3414567525120	ER 25	120	42	42	185,4	93	52-82		1	1,67	
	2-20	E341456753270	ER 32	70	50	50	135,4	43	0-27		1	1,27	
	2-20	E3414567532120	ER 32	120	50	50	185,4	93	33-77		1	1,94	
	3-26	E3414567540100	ER 40	100	63	63	165,4	73	27-50		1	1,97	
BT40 AD	3-26	E404156754075	ER 40*	75	63	63	140,4	48	3-25	*	1	1,42	
BT50 ADB	0,5-10	E3416567516120	ER 16	120	32	32	221,8	82	76-90		2	3,84	
	1-16	E341656752590	ER 25	90	42	42	191,8	52	22-52		2	3,83	
	2-20	E341656753290	ER 32	90	50	50	191,8	52	0-47		2	3,92	
	2-20	E3416567532150	ER 32	150	50	50	251,8	112	29-107		2	4,7	
	3-26	E3416567540100	ER 40	100	63	63	201,8	62	16-50		2	4,31	

For ER collets, see page(s) 302-303

ER extensions, see page(s) 301

* Chuck ER40/A75 is type AD (E4041) without flange coolant through, instead type ADB (E3414)

Accessories**

For size	Seal nut	Spanner
ER 16	08B587516IC	03B587516
ER 25	08B587525IC	03B587525
ER 32	08B587532IC	03B587532
ER 40	08B587540IC	03B587540
ER 40*	08B587540IC	03B587540

Spare Parts

For size	Nut	Stop screw
ER 16	08B587516X	19B58711
ER 25	08B587525X	19B58718
ER 32	08B587532X	19B58722
ER 40	08B587540X	19B58730
ER 40*	08B587540X	19B58730

Please check availability in current price and stock-list

** For ER sealing rings, see page(s) 304



- Direct run-out 5 μ m maximum

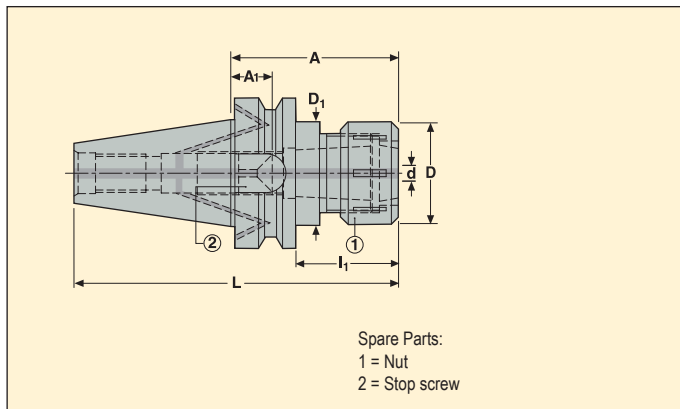

Taper	Capacity d mm	Part No.	Chuck & Collet Size	Dimensions in mm						Balancing	
				A	D	D ₁	L	I ₁	A ₁ min-max		
BT40 ADB	4-32	E341458733290	OZ 32	90	72	63	155,4	63	15-25	2	1,89
	4-32	E341658733290	OZ 32	90	72	72	191,8	42	4-25	2	4,18
BT50 ADB											

For OZ collets, see page(s) 305

Accessories

For taper	Key
BT40 ADB	03B587332
BT50 ADB	03B587332

Spare Parts

For taper	Nut	Stop screw
BT40 ADB	08B587332	19B58727
BT50 ADB	08B587332	19B58735

Please check availability in current price and stock-list



- Run-out 40 µm maximum at 2,5xd

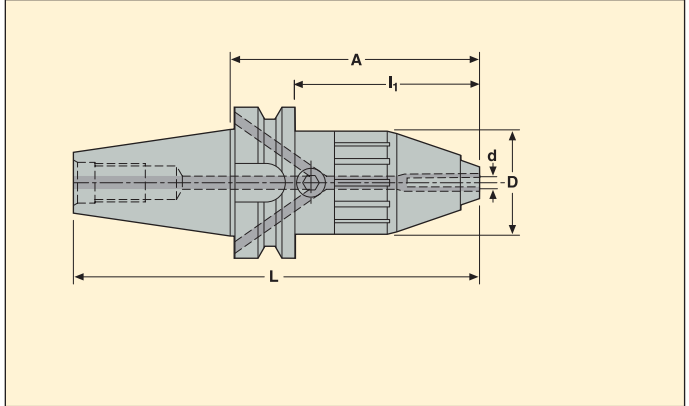

Taper	Capacity d mm	Part No.	Dimensions in mm				Balancing	
			A	D	L	I ₁		
BT40 ADB	1-13	E3414508513	104	43	169,4	77	2	1,41
	2,5-16	E3416508516	131	56	232,8	93	2	4,66
BT50 ADB								

Accessories

For Capacity d	Key
	
1-13	H06-4
2,5-16	H06-4

Please check availability in current price and stock-list

EPB 5867 – Tapping chucks for synchronized tapping, with micro-compensation



- Inbuilt axial micro flexure (+/- 0,5 mm) prevents from tapping tap stress
- Tap fitting based on ER tapping collets with square drive
- Maximum coolant pressure 80 bar

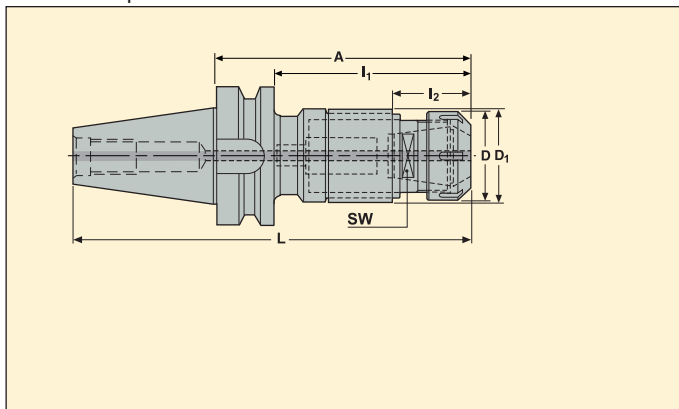

Taper	Tapping range	Part No.	Size	Dimensions in mm								Balancing	 KG
				A	D	D ₁	L	I ₁	I ₂	SW			
BT30 AD	M2-M5	E404058671182	ER 11	82	18,7	23,5	130,4	60	24,1	12,70	-	0,60	
	M4-M12	E4040586720105	ER 20	105,2	33,7	35	153,6	83,2	40,3	22,00	-	0,90	
	M8-M20	E4040586725125	ER 25	124,6	42	44	173	102,6	42,1	28,00	-	1,20	
BT40 AD	M4-M12	E4041586720110	ER 20	110,2	33,7	35	175,6	83,2	40,3	22,00	-	1,40	
	M8-M20	E4041586725130	ER 25	129,6	42	44	195	102,6	42,1	28,00	-	1,80	
BT50 AD	M4-M12	E5766586720125	ER 20	125,2	33,7	35	227	87,2	40,3	22,00	-	4,00	
	M8-M20	E5766586725145	ER 25	144,6	42	44	246,4	106,6	42,1	28,00	-	4,40	
	M16-M30	E5766586740174	ER 40	174	62,7	62	275,8	136	52	39,60	-	5,70	

For ER tapping collets with square drive, see page(s) 308

Accessories

For size	Locking key	Spanner
ER 11	5680092-03	03B587511UM
ER 20	5680092-04	03B587520UM
ER 25	5680092-05	03B587525
ER 40	5680092-06	03B587540

Spare Parts

For size	Nut
ER 11	5533050-07
ER 20	5533051-02
ER 25	5533051-03
ER 40	5533051-05

Please check availability in current price and stock-list

For EPB 5867 sealing rings, see page(s) 309



- With extension and compression

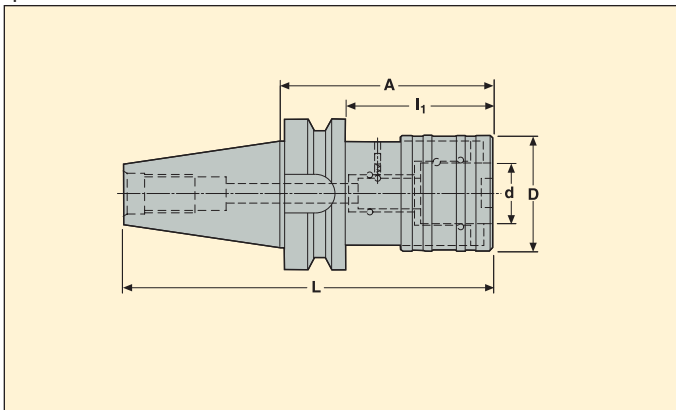

Taper	Tapping range	Part No.	For tap adapter		Dimensions in mm						
			Size	d mm	Compression	Extension	A	D	L	I ₁	
BT40 A	M3-M12	ET404152832	2	19	7,5	7,5	70	39	135,4	43	1,21
	M8-M20	ET404152833	3	31	12,5	12,5	100	59	165,4	73	1,89
BT50 A	M3-M12	ET576652832	2	19	7,5	7,5	80	39	181,8	42	3,8
	M8-M20	ET576652833	3	31	12,5	12,5	105	59	206,8	67	4,42
	M14-M33	ET576652834	4	48	20	20	140	84	241,8	102	5,98

Please check availability in current price and stock-list
 For quick change tap adapters, see page(s) 311-312

Monobloc holders BT JIS

EPB 5865 – ER tapping chucks for synchronized tapping – DIN 6499

BT JIS B 6339-ADB



- Direct run-out 5 μm maximum
- No compensation

Accessories:
 3 = Seal ring*
 4 = Seal nut

Spare Parts:
 1 = Bolt
 5 = Driving system

Taper	Tapping range	Part No.	For tap adapter		Dimensions in mm							Balancing	
			Size	d mm	A	D	D ₁	L	I ₁	I ₂	A ₁		
BT40 ADB	M5-M20	E341458652595	ER 25	1-16	95	42	42	160,4	68	–	49	2	1,34
	M5-M30	E3414586532110	ER 32	2-20	110	50	63	175,4	83	37	53,5	2	2,07
BT50 ADB	M5-M30	E3416586532120	ER 32	2-20	120	50	63	221,8	82	37	63,5	2	4,58
	M12-M33	E3416586540130	ER 40	3-26	130	63	63	231,8	92	–	67,5	2	4,87

For ER collets, see page(s) 302-303

Accessories*

For size	Key	Seal nut
ER 25	03B587525	08B587525IC
ER 32	03B587532	08B587532IC
ER 40	03B587540	08B587540IC

Spare Parts

For size	Driving system	Nut
ER 25	90T586525	08B587525X
ER 32	90T586532	08B587532X
ER 40	90T586532	08B587540X

Please check availability in current price and stock-list
 * For ER type sealing rings, see page(s) 304



- Direct run-out 5 µm maximum

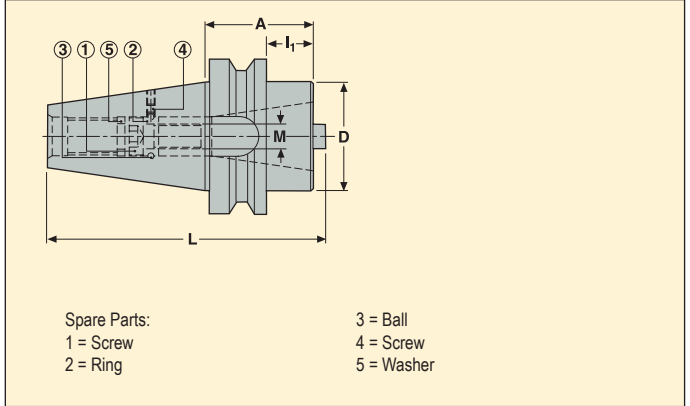

Taper	For taper	Part No.	Dimensions in mm				M mm	Balancing	
			A	D	L	I ₁			
BT50 A	40 DIN 69871/BT/CAT	E57665434070T	70	70	179,8	32	M16	2	4,10

Spare Parts

For	Balls	Plug	Ring	Screw	Washer
..4070T	901B04	950A0505	02B54240	950E1670	15B54240

Please check availability in current price and stock-list

EPB 5023 - Greenstock blanks

BT JIS B 6339-ADB

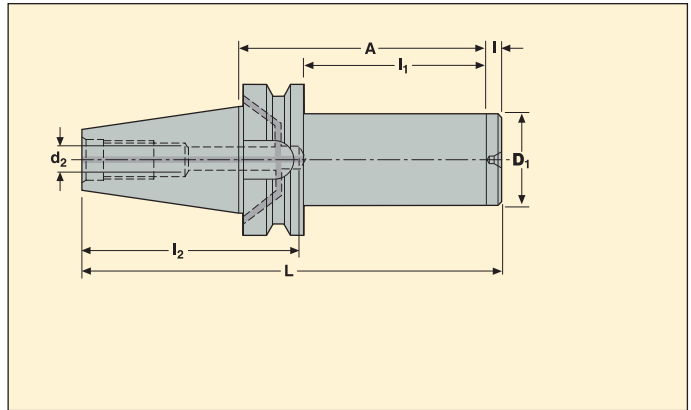

Taper	Part No.	Dimensions in mm							Balancing	
		A	D ₁	L	d ₂	I	I ₁	I ₂		
BT40 ADB	E3414502363250	250	63	323,4	10	8	215	85	2	6,58
BT50 ADB	E3416502363315	315	63	424,8	21	8	277	130	2	10,42
	E3416502395315	315	95	424,8	21	8	277	130	2	20,00

Please check availability in current price and stock-list

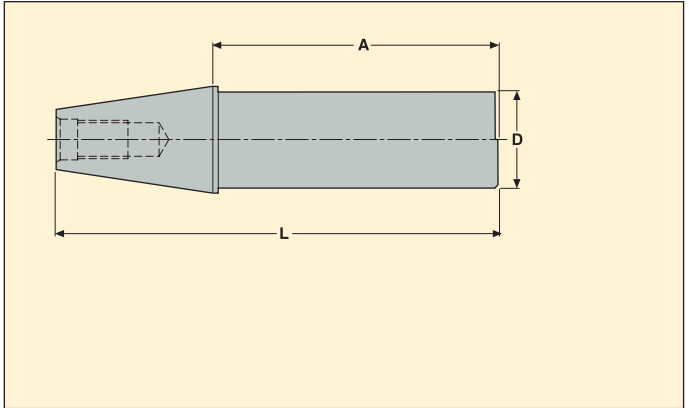

- With protective case and measurement report

Taper	Part No.	Dimensions in mm			
		A	D	L	
BT40	E404158640330	330	40	395,4	3,64

Please check availability in current price and stock-list
 Note: For BT50, use suitable DIN50 Test/Control bar (E4471 586 50330)

The modular milling solution for medium size cutters

Combimaster tools achieve optimum access and shortest overhang.

Stability, precision and balance are improved vs. classic assemblies, e.g. Weldon or collet chucks. Extensions and reducers to realise optimum tool length.

Modular: The Graflex®/ Combimaster as well as Seco-Capto™/ Combimaster arbors instead holders (Machining Navigator Seco-Capto™) allow you to mix systems. Combimaster with Shrinkfit front ends are also available to hold small tools.

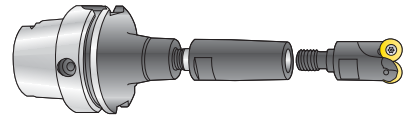

Balancing quality

Most arbors are fine balanced, except Steadyline™ Combimaster arbors, being pre-balanced. See Product pages.

Combimaster arbors, code key

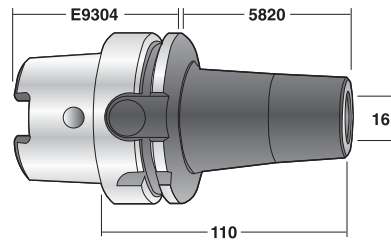
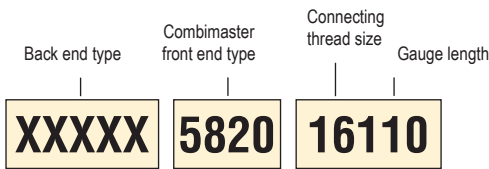

Combimaster arbors, front end types

(see also specific Guide page for damped Steadyline Combimaster arbors)

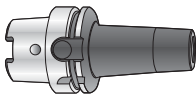

5820
Entirely tapered

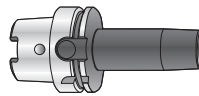

5821
Cylindrical and front tapered*



5822
Entirely cylindrical

* Except Type 5821 Cylindrical and Morse Taper extensions, see specific shape in Product pages.

Combimaster heads

Note: Combimaster cutter heads are shown in Machining Navigator Milling.

Recommended Combimaster connecting tightening torques

Connecting thread size	Tightening torque	Mounting key size (mm)
M06	10 Nm	9
M08	25 Nm	11
M10	40 Nm	15
M12	60 Nm	19
M16	80 Nm	26

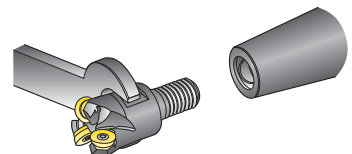

Steadyline™ vibration damping Combimaster arbors, EPB K820/K821

See also Guide page 'Combimaster arbors, General information'.

See also Guide page 'Steadyline™ vibration damping system, General information'.

Steadyline™ Combimaster arbors complete the Steadyline™ range of milling holders, between shell mill and Shrinkfit Steadyline™ holders.

Combimaster assemblies achieve optimum access to the workpiece. Stability, precision and balance are improved vs. classic assemblies, e.g. Weldon or collet chucks. Steadyline™ vibration damping Combimaster arbors are a patented solution to boost your productivity or offer you a solution in long overhang situations.

Steadyline™ Combimaster holders are available in several length projections, long (often available as an alternative to the same conventional Combimaster holder's length) and longer (adding longer projections to the range of conventional Combimaster arbors).

Steadyline™ Combimaster holder types



EPB K820
Steadyline™ Combimaster
entirely tapered



EPB K821
Steadyline™ Combimaster
cylindrical and front tapered

EPB K820

Steadyline™ Combimaster arbors are tapered to provide the best compromise between rigidity and accessibility to the workpiece.

EPB K821

Steadyline™ Combimaster arbors have a cylindrical body profile for a slimmer access to the workpiece.

Balancing

Pre-balanced : see Product pages 'Balancing' columns.

Steadyline™ Combimaster arbors, main operating instructions

This summarises the instructions delivered with the arbors, as a pre-information.

Combimaster arbors with Steadyline™ vibration damping system are designed to directly hold Combimaster heads. Addition of Combimaster intermediates is not recommended, as it will reduce the damper's effect.

Note: Combimaster cutter heads are shown in Machining Navigator Milling.

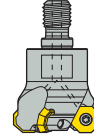

Recommended cutting conditions and maximum temperature

Make sure never to exceed the maximum RPM of the arbors (indicated on the arbors and listed in the Product pages).

Inappropriate cutting conditions could cause vibrations of the milling assembly, this would prevent the damper operating properly and would damage the tool, the tool holder, the machine as well as the workpiece: set the cutting conditions in order to stay vibration free.

Optimal cutting conditions, selection procedure:

1. Cutting speed V_c and feed f : select the average values recommended for the cutter and inserts.
2. The width of cut a_e and the depth of cut a_p are the parameters to fine tune. It is possible to increase them inside cutter and inserts recommendations, while staying vibration free.

BEWARE: contrary to the use of classic long holders, the machining cannot be stabilised through additional radial force (e.g. by raising the feed).

Make sure the Steadyline™ Combimaster holder body never exceeds a maximum temperature of 80°C when in use.

Design 1 (K820)

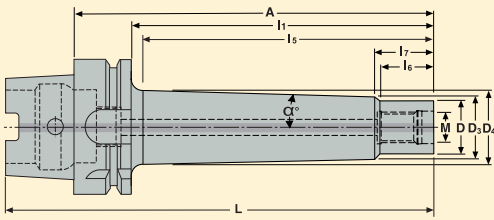

Design 2 (K821)

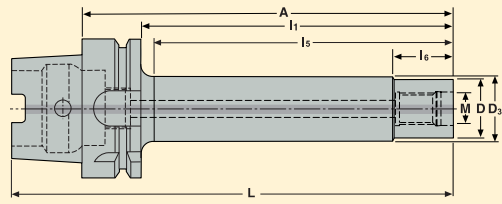

- With dynamic damping, ready to use
- With through coolant

Taper	Connecting thread size	Part No.	Dimensions in mm										α°	Design	Max rpm	Balancing	
			A	L	I ₁	I ₅	I ₆	I ₇	D	D ₃	D ₄						
HSK-A63	M10	E9304K82010185	185	217	159	154,2	20,0	22,8	18,5	24,0	36,6	2,8	1	12000	2	1,51	
	M12	E9304K82012185	185	217	159	154,2	20,0	23,4	23,0	29,5	42,0	2,8	1	12000	2	1,90	
	M16	E9304K82016185	185	217	159	154,2	20,0	23,7	30,0	37,0	59,5	2,8	1	10000	2	2,59	
	M16	E9304K82016235	235	267	209	190,6	20,0	23,7	30,0	37,0	53,0	2,8	1	8000	2	3,50	
	M16	E9304K82116160	160	192	134	129,0	22,0	-	30,0	30,5	-	-	2	10000	2	1,40	
HSK-A100	M12	E9306K82012235	235	285	206	201,2	20,0	23,4	23,0	29,5	46,6	2,8	1	8000	2	4,00	
	M16	E9306K82016235	235	285	206	201,2	20,0	23,7	30,0	37,0	54,0	2,8	1	8000	2	4,78	
	M16	E9306K82016285	285	335	256	251,2	20,0	23,7	30,0	37,0	58,8	2,8	1	6000	2	5,86	
	M16	E9306K82116185	185	235	156	151,0	22,0	-	30,0	30,5	-	-	2	8000	2	2,91	

Please check availability in current price and stock-list
For HSK sealing plugs, coolant tubes and tube spanners, see page(s) 287

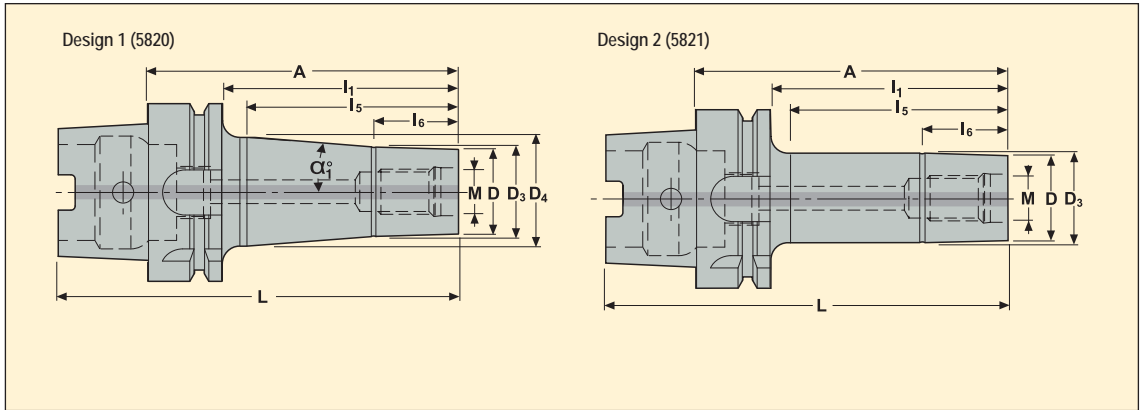

Taper	Connecting thread size	Part No.	Dimensions in mm									α_1°	Design	Balancing	
			A	L	I ₁	I ₅	I ₆	D	D ₃	D ₄					
HSK-A40	M6	E930258200645	45	65	25	15	10,0	11,0	11,7	13,5	10,2	1	1	0,30	
HSK-A63	M6	E930458200660	60	92	34	25	10,0	11,0	11,7	14,5	5,3	1	1	0,70	
	M8	E930458200860	60	92	34	25	10,0	13,5	15,7	18,5	5,3	1	1	0,70	
	M8	E930458200885	85	117	59	50	15,0	13,5	15,7	20,0	3,5	1	1	0,80	
	M10	E930458201060	60	92	34	25	10,0	18,5	19,7	23,0	6,3	1	1	0,80	
	M10	E930458201085	85	117	59	50	15,0	18,5	19,7	24,5	3,9	1	1	0,80	
	M10	E9304582010135	135	167	109	100	20,0	18,5	19,7	27,5	2,8	1	1	1,00	
	M10	E930458211060	60	92	34	25	10,0	18,5	18,5	–	–	2	1	0,70	
	M12	E930458201260	60	92	34	25	10,0	23,0	24,7	28,5	7,2	1	1	0,80	
	M12	E930458201285	85	117	59	50	20,0	23,0	24,7	30,0	5,0	1	1	0,90	
	M12	E9304582012110	110	142	84	75	25,0	23,0	24,7	31,5	3,9	1	1	1,00	
	M12	E9304582012135	135	167	109	100	30,0	23,0	24,7	33,0	3,4	1	1	1,20	
	M12	E930458211260	60	92	34	25	10,0	23,0	23,5	–	–	2	1	0,80	
	M12	E930458211285	85	117	59	50	20,0	23,0	23,5	–	–	2	1	0,80	
	M16	E930458201660	60	92	34	25	10,0	30,0	31,7	35,5	6,9	1	1	0,90	
	M16	E930458201685	85	117	59	50	20,0	30,0	31,7	37,0	5,0	1	1	1,10	
	M16	E9304582016110	110	142	84	75	25,0	30,0	31,7	38,5	3,9	1	1	1,20	
	M16	E9304582016135	135	167	109	100	30,0	30,0	31,7	40,0	3,4	1	1	1,40	
	HSK-A100	M16	E9304582016185	185	217	159	150	35,0	30,0	31,7	50,0	4,5	1	1	2,10
M16		E930458211685	85	117	59	50	20,0	30,0	30,5	–	–	2	1	1,00	
M16		E9304582116110	110	142	84	75	25,0	30,0	30,5	–	–	2	1	1,10	
M16		E9304582116135	135	167	109	100	30,0	30,0	30,5	–	–	2	1	1,20	
M8		E930658200885	85	135	56	50	15,0	13,5	15,7	24,5	7,2	1	1	2,10	
M10		E930658201085	85	135	56	50	15,0	18,5	19,7	29,0	7,6	1	1	2,20	
M10		E9306582010110	110	160	81	75	20,0	18,5	19,7	32,5	6,6	1	1	2,30	
M12		E930658201285	85	135	56	50	20,0	23,0	24,7	35,0	9,7	1	1	2,30	
M12		E9306582012110	110	160	81	75	25,0	23,0	24,7	38,0	7,6	1	1	2,40	
M12		E9306582012135	135	185	106	100	30,0	23,0	24,7	42,5	6,6	1	1	2,60	
M12		E9306582012185	185	235	156	150	30,0	23,0	24,7	42,5	4,2	1	1	2,90	
M16		E930658201685	85	135	56	50	30,0	30,0	31,7	42,5	10,2	1	1	2,40	
M16	E9306582016135	135	185	106	100	30,0	30,0	31,7	49,0	7,0	1	1	2,90		
M16	E9306582016185	185	235	156	150	35,0	30,0	31,7	50,0	4,5	1	1	3,30		

Please check availability in current price and stock-list
 For HSK sealing plugs, coolant tubes and tube spanners, see page(s) 287

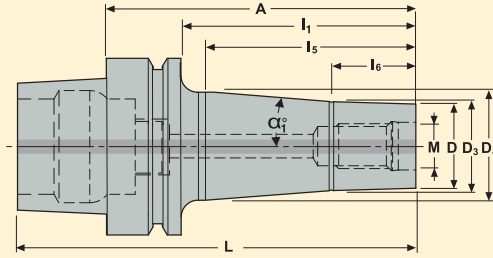

Taper	Connecting thread size	Part No.	Dimensions in mm								α_1°	Balancing	
			A	L	I ₁	I ₅	I ₆	D	D ₃	D ₄			
HSK-E32	M6	E934158200650	50	66	30	25	10	11,0	11,7	14,5	5,3	1	0,20
	M8	E934158200850	50	66	30	25	10	13,5	15,7	18,5	5,3	1	0,20
HSK-E40	M6	E934258200650	50	70	30	25	10	11,0	11,7	14,5	5,3	1	0,30
	M8	E934258200875	75	95	55	50	15	13,5	15,7	20,0	3,5	1	0,30
	M10	E934258201075	75	95	55	50	15	18,5	19,7	24,5	3,9	1	0,40
HSK-E50	M6	E934358200655	55	80	29	25	10	11,0	11,7	14,5	5,3	1	0,50
	M8	E934358200855	55	80	29	25	10	13,5	15,7	18,5	5,3	1	0,50
	M10	E934358201080	80	105	54	50	15	18,5	19,7	24,5	3,9	1	0,60
	M12	E934358201280	80	105	54	50	20	23,0	24,7	30,0	5,0	1	0,70
	M16	E934358201680	80	105	54	50	20	30,0	31,7	37,0	5,0	1	0,80

Please check availability in current price and stock-list
 *For HSK sealing plugs, coolant tubes and tube spanners, see page(s) 287

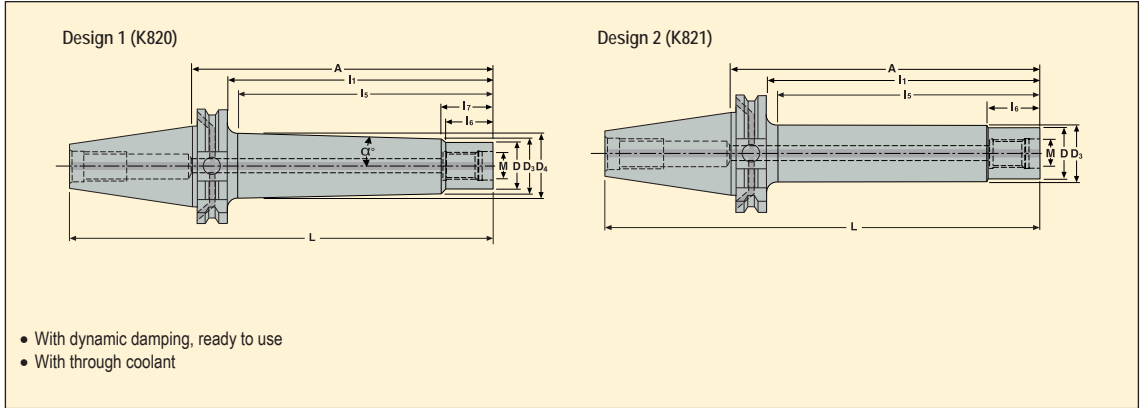

Taper	Connecting thread size	Part No.	Dimensions in mm										α°	Design	Max rpm	Balancing	
			A	L	l ₁	l ₅	l ₆	l ₇	D	D ₃	D ₄	I					
DIN40 ADB	M12	E3469K82012185	185	253,4	165,9	—	20,0	24,0	23,0	30,0	42,7	2,8	1	10000	2	2,20	
	M16	E3469K82016185	185	253,4	165,9	—	20,0	24,0	30,0	37,0	50,2	2,8	1	10000	2	2,80	
	M16	E3469K82016235	235	303,4	215,9	—	20,0	24,0	30,0	37,0	50,0	2,8	1	8000	2	3,70	
	M16	E3469K82116160	160	228,4	140,9	135,9	20,0	—	30,0	30,5	—	—	2	10000	2	1,70	
DIN50 ADB	M16	E3471K82016235	235	336,7	215,9	211,1	20,0	24,0	30,0	37,0	55,0	2,8	1	8000	2	5,50	
	M16	E3471K82016285	285	386,7	265,9	261,1	20,0	24,0	30,0	37,0	59,8	2,8	1	6000	2	6,60	
	M16	E3471K82116185	185	286,7	165,9	160,9	22,0	—	30,0	30,5	—	—	2	10000	2	3,50	

Please check availability in current price and stock-list

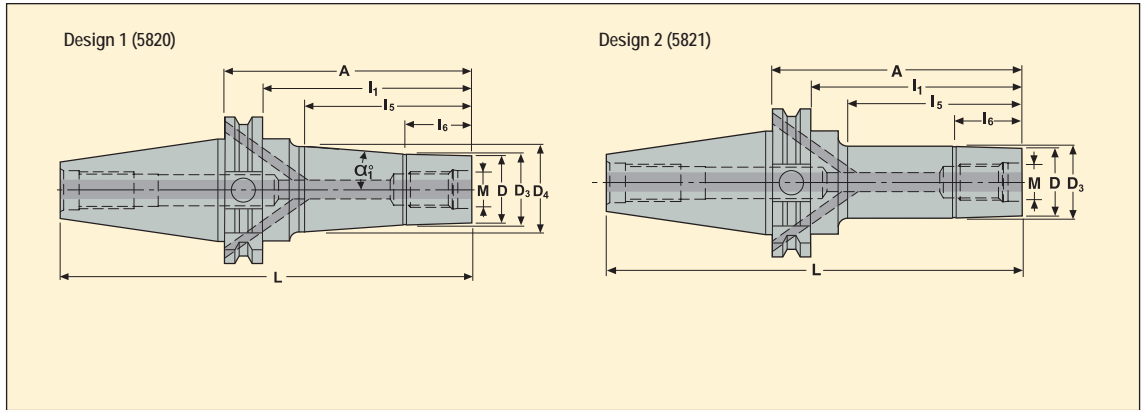

Taper	Connecting thread size	Part No.	Dimensions in mm									α_i°	Design	Balancing	
			A	L	I ₁	I ₅	I ₆	D	D ₃	D ₄					
DIN40 ADB/ CAT40	M6	E347658200660	60	128,4	41	25	10	11,0	11,7	14,5	5,3	1	1	1,00	
	M8	E347658200860	60	128,4	41	25	10	13,5	15,7	18,5	5,3	1	1	1,00	
	M10	E347658201040	40	108,4	21	5	5	18,5	19,7	19,7	6,8	1	1	1,00	
	M10	E347658201060	60	128,4	41	25	10	18,5	19,7	23,0	6,3	1	1	1,00	
	M10	E347658201085	85	153,4	66	50	15	18,5	19,7	24,5	3,9	1	1	1,10	
	M10	E3476582010135	135	203,4	116	100	20	18,5	19,7	27,5	2,8	1	1	1,30	
	M10	E347658211060	60	128,4	41	25	10	18,5	18,5	–	–	2	1	1,00	
	M12	E347658201240	40	108,4	21	5	5	23,0	24,7	24,7	9,6	1	1	1,00	
	M12	E347658201260	60	128,4	41	25	10	23,0	24,7	28,5	7,2	1	1	1,10	
	M12	E347658201285	85	153,4	66	50	20	23,0	24,7	30,0	5,0	1	1	1,20	
	M12	E3476582012110	110	178,4	91	75	25	23,0	24,7	31,5	3,9	1	1	1,30	
	M12	E3476582012185	185	253,4	166	150	30	23,0	24,7	42,5	4,2	1	1	1,80	
	M12	E347658211260	60	128,4	41	25	10	23,0	23,5	–	–	2	1	1,10	
	M12	E347658211285	85	153,4	66	50	20	23,0	23,5	–	–	2	1	1,10	
	M16	E347658201640	40	108,4	21	5	5	30,0	31,7	31,7	9,6	1	1	1,00	
	M16	E347658201660	60	128,4	41	25	10	30,0	31,7	35,5	7,2	1	1	1,10	
	M16	E347658201685	85	153,4	66	50	20	30,0	31,7	37,0	5,0	1	1	1,30	
	M16	E3476582016110	110	178,4	91	75	25	30,0	31,7	38,5	3,9	1	1	1,50	
M16	E3476582016135	135	203,4	116	100	30	30,0	31,7	40,5	3,6	1	1	1,60		
M16	E3476582016185	185	253,4	166	150	35	30,0	31,7	43,5	2,9	1	1	2,10		
M16	E347658211685	85	153,4	66	50	20	30,0	30,5	–	–	2	1	1,20		
M16	E3476582116110	110	178,4	91	75	25	30,0	30,5	–	–	2	1	1,30		
M16	E3476582116135	135	203,4	116	100	30	30,0	30,5	–	–	2	1	1,50		
DIN50 ADB/ CAT50	M12	E347858201295	95	196,7	76	50	20	23,0	24,7	35,0	9,7	1	1	3,30	
	M12	E3478582012145	145	246,7	126	100	30	23,0	24,7	41,0	6,6	1	1	3,60	
	M12	E3478582012195	195	296,7	176	150	30	23,0	24,7	42,5	4,2	1	1	3,90	
	M12	E3478582012245	245	346,7	226	200	30	23,0	24,7	47,5	3,8	1	1	4,50	
	M16	E347858201695	95	196,7	76	50	20	30,0	31,7	42,5	10,2	1	1	3,40	
	M16	E3478582016145	145	246,7	126	100	30	30,0	31,7	49,0	7,0	1	1	4,10	
	M16	E3478582016195	195	296,7	176	150	35	30,0	31,7	50,0	4,5	1	1	4,60	
	M16	E3478582016245	245	346,7	226	200	35	30,0	31,7	55,0	4,0	1	1	5,00	
	M16	E3478582016295	295	396,7	276	250	35	30,0	31,7	59,5	3,7	1	1	5,80	

Please check availability in current price and stock-list

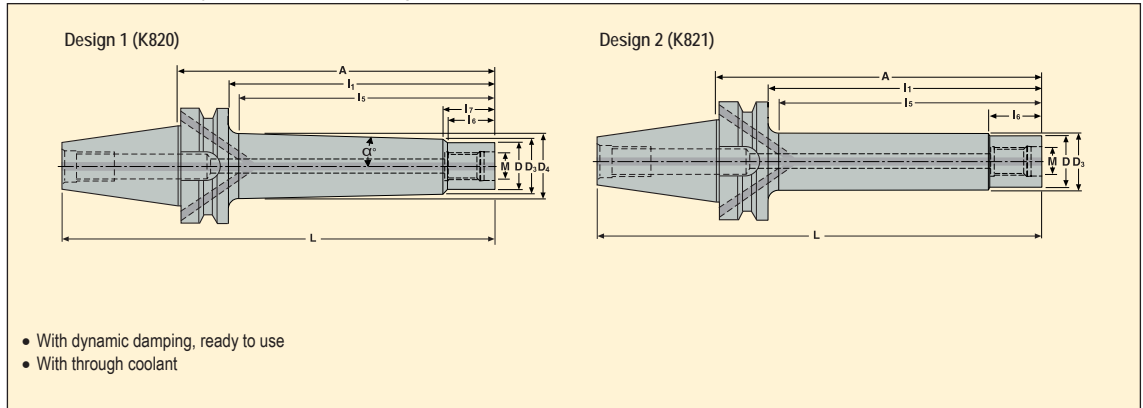

- With dynamic damping, ready to use
- With through coolant

Taper	Connecting thread size	Part No.	Dimensions in mm									α°	Design	Max rpm	Balancing	
			A	L	I ₁	I ₅	I ₆	I ₇	D	D ₃	D ₄					
BT40 ADB	M12	E3414K82012185	185	250,4	158	153,2	20,0	24,0	23,0	30,0	41,9	2,8	1	10000	2	2,20
	M16	E3414K82016185	185	250,4	158	153,2	20,0	24,0	30,0	37,0	49,4	2,8	1	10000	2	2,80
	M16	E3414K82016235	235	300,4	208	203,2	20,0	24,0	30,0	37,0	54,2	2,8	1	8000	2	3,70
	M16	E3414K82116160	160	225,4	133	128,0	22,0	-	30,0	30,5	-	-	2	10000	2	1,80
BT50 ADB	M16	E3416K82016235	235	336,8	197	192,2	20,0	24,0	30,0	37,0	53,2	2,8	1	8000	2	6,10
	M16	E3416K82016285	285	386,8	247	242,2	20,0	24,0	30,0	37,0	57,0	2,8	1	6000	2	7,20
	M16	E3416K82116185	185	286,8	147	142,0	22,0	-	30,0	30,5	-	-	2	10000	2	4,40

Please check availability in current price and stock-list

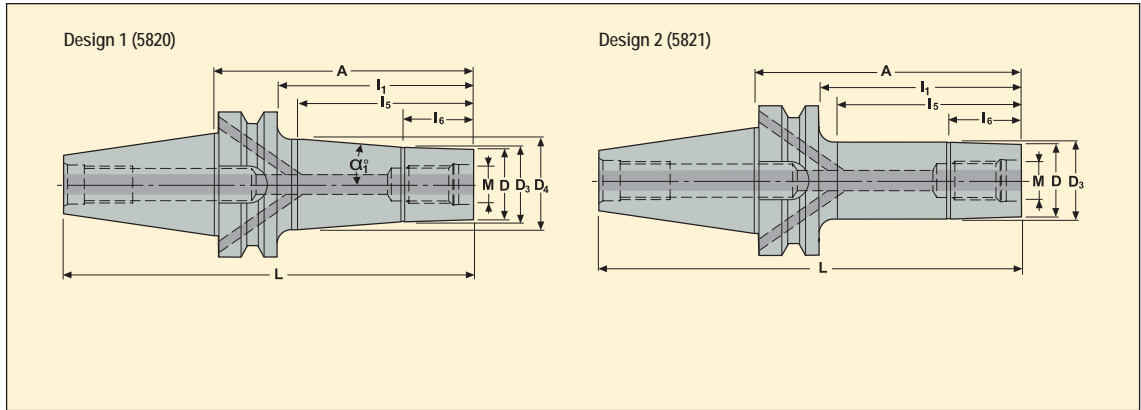

Taper	Connecting thread size	Part No.	Dimensions in mm								α_1°	Design	Balancing		
			A	L	I ₁	I ₅	I ₆	D	D ₃	D ₄					
BT40 ADB	M6	E341458200660	60	125,4	33	25	10	11,0	11,7	14,5	5,3	1	1	1,00	
	M8	E341458210860	60	125,4	33	25	10	13,5	14,5	-	-	2	1	1,00	
	M10	E341458201060	60	125,4	33	25	10	18,5	19,7	23,0	6,3	1	1	1,10	
	M10	E341458201085	85	150,4	58	50	15	18,5	19,7	24,5	3,9	1	1	1,10	
	M10	E3414582010135	135	200,4	108	100	20	18,5	19,7	27,5	2,8	1	1	1,30	
	M10	E341458211060	60	125,4	33	25	10	18,5	19,7	-	-	2	1	1,00	
	M12	E341458201240	40	105,4	13	5	5	23,0	24,7	24,7	0	1	1	1,00	
	M12	E341458201260	60	125,4	33	25	10	23,0	24,7	28,5	7,2	1	1	1,10	
	M12	E341458201285	85	150,4	58	50	20	23,0	24,7	30,0	5,0	1	1	1,20	
	M12	E3414582012110	110	175,4	83	75	25	23,0	24,7	31,5	3,9	1	1	1,30	
	M12	E3414582012135	135	200,4	108	100	30	23,0	24,7	33,0	3,4	1	1	1,40	
	M12	E341458211260	60	125,4	33	25	10	23,0	23,5	-	-	2	1	1,10	
	M12	E341458211285	85	150,4	58	50	20	23,0	23,5	-	-	2	1	1,10	
	M16	E341458201640	40	105,4	13	5	5	30,0	31,7	31,7	0	1	1	1,10	
	M16	E341458201660	60	125,4	33	25	10	30,0	31,7	35,5	7,2	1	1	1,20	
	M16	E341458201685	85	150,4	58	50	20	30,0	31,7	37,0	5,0	1	1	1,30	
M16	E3414582016110	110	175,4	83	75	25	30,0	31,7	38,5	3,9	1	1	1,50		
M16	E3414582016135	135	200,4	108	100	30	30,0	31,7	40,5	3,6	1	1	1,70		
M16	E3414582016185	185	250,4	158	150	35	30,0	31,7	50,0	4,5	1	1	2,40		
BT50 ADB	M12	E341658201295	95	196,8	57	50	20	23,0	24,7	35,0	9,7	1	1	3,80	
	M12	E3416582012145	145	246,8	107	100	30	23,0	24,7	41,0	6,6	1	1	4,10	
	M12	E3416582012195	195	296,8	157	150	30	23,0	24,7	42,5	4,2	1	1	4,40	
	M16	E341658201695	95	196,8	57	50	20	30,0	31,7	42,5	10,2	1	1	3,90	
	M16	E3416582016145	145	246,8	107	100	30	30,0	31,7	49,0	7,0	1	1	4,40	
	M16	E3416582016195	195	296,9	157	150	35	30,0	31,7	50,0	4,5	1	1	4,80	
	M16	E3416582016245	245	346,8	207	200	35	30,0	31,7	55,0	4,0	1	1	5,40	
	M16	E3416582016295	295	396,8	257	250	35	30,0	31,7	59,5	3,7	1	1	6,30	

Please check availability in current price and stock-list

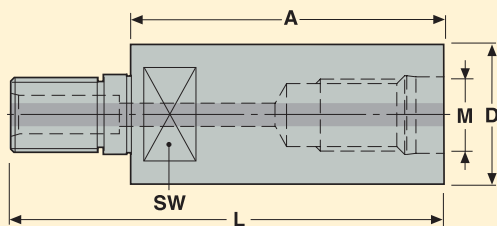

Combimaster shank size	Connecting thread size	Part No.	Dimensions in mm				Balancing	
			A	L	D	SW		
M6	M6	BS00658200625	25	38,5	11,0	9	2	0,10
	M8	BS00858200830	30	47,75	13,5	11	2	0,10
M10	M10	BS01058201035	35	53,75	18,5	15	2	0,10
	M12	BS01258201240	40	61,75	23,0	19	2	0,20
M16	M16	BS01658201640	40	62,75	30,0	26	2	0,20

Please check availability in current price and stock-list

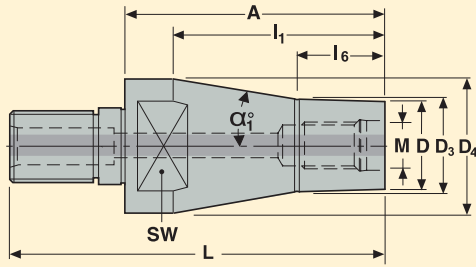

Combimaster shank size	Connecting thread size	Part No.	Dimensions in mm								α ₁ °	Balancing	
			A	L	I ₁	I ₆	D	D ₃	D ₄	SW			
M8	M6	BS00858200625	25	42,75	14	6	11,0	11,7	13,5	11	6,4	2	0,10
M10	M6	BS01058200635	35	53,75	22	6	11,0	11,7	18,5	15	12,0	2	0,10
	M8	BS01058200830	30	48,75	17	8	13,5	15,7	18,5	15	8,8	2	0,10
M12	M10	BS01258201035	35	56,75	24	8	18,5	19,7	23,0	19	5,9	2	0,10
M16	M10	BS01658201060	60	82,75	49	8	18,5	19,7	30,0	26	7,2	2	0,30
	M12	BS01658201240	40	62,75	29	8	23,0	24,7	30,0	26	7,2	2	0,20

Please check availability in current price and stock-list

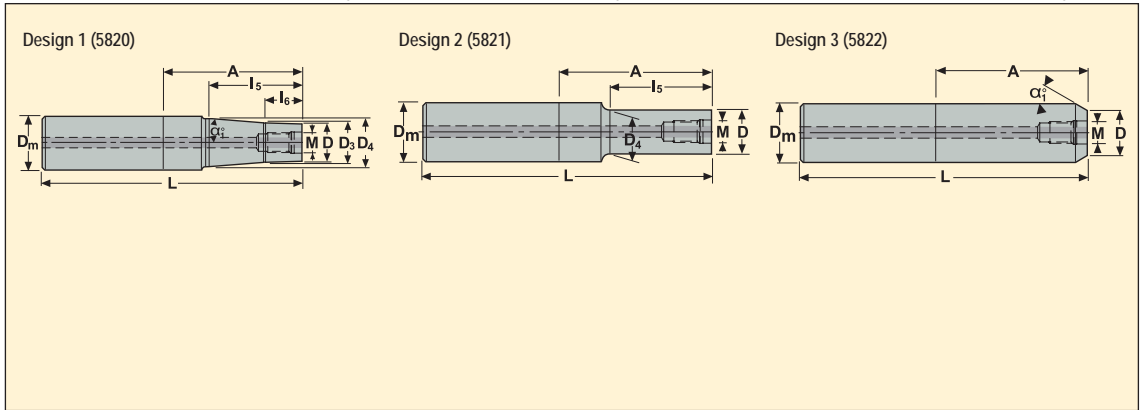

Cyl. Shank D _m	Connecting thread size	Part No.	Dimensions in mm							α ₁ °	Design	Balancing	KG
			A	L	I ₅	I ₆	D	D ₃	D ₄				
12	M6	BD01258220660	60	105	-	-	11,0	-	-	-	3	2	0,10
	M6	BD01258220695E	95	140	-	-	11,0	-	-	-	3	2	0,30
14	M8	BD01458220860	60	105	-	-	13,5	-	-	-	3	2	0,20
	M8	BD01458220895E	95	140	-	-	13,5	-	-	-	3	2	0,80
16	M8	BD01658220865	65	113	-	-	13,5	-	-	-	3	2	0,20
	M8	BD016582208105E	105	153	-	-	13,5	-	-	-	3	2	0,40
	M8	BD016582108105E	105	153	50	-	13,5	-	14,5	-	2	2	0,40
18	M10	BD01858221070	70	118	-	-	18,0	-	-	-	3	2	0,30
	M10	BD018582210125E	125	173	-	-	18,0	-	-	-	3	2	0,80
20	M10	BD02058221075	75	125	-	-	18,5	-	-	-	3	2	0,30
	M10	BD02058211040D	40	90	25	-	18,5	-	18,5	-	2	2	0,50
	M10	BD020582110110	110	160	65	-	18,5	-	18,5	-	2	2	0,40
	M10	BD020582110110D	110	160	65	-	18,5	-	18,5	-	2	2	0,80
25	M12	BD02558221280	80	136	-	-	23,0	-	-	-	3	2	0,50
	M12	BD025582112185E	185	241	85	-	23,0	-	23,5	-	2	2	1,60
	M12	BD025582112185	185	241	85	-	23,0	-	23,5	-	2	2	0,90
	M12	BD025582112185D	185	241	85	-	23,0	-	23,0	-	2	2	1,70
32	M12	BD032582012100	100	160	65	25	23,0	24,7	31,0	4,5	1	2	0,90
	M12	BD032582012240	240	300	145	30	23,0	24,7	31,0	1,6	1	2	1,40
	M16	BD03258221695	95	155	-	-	30,0	-	-	-	3	2	0,90
	M16	BD032582116100	100	160	65	-	30,0	-	30,0	-	2	2	0,90
	M16	BD032582116100D	100	160	65	-	30,0	-	30,0	-	2	2	2,00
	M16	BD032582116145D	145	205	110	-	30,0	-	30,0	-	2	2	2,60
	M16	BD032582116240	240	300	145	-	30,0	-	30,0	-	2	2	1,70
	M16	BD032582116240D	240	300	145	-	30,0	-	30,0	-	2	2	3,80
40	M16	BD04058201690	90	160	65	25	30,0	31,7	39,0	5,2	1	2	1,40
	M16	BD040582016135	135	205	110	35	30,0	31,7	39,0	2,8	1	2	1,70
	M16	BD040582016230	230	300	145	35	30,0	31,7	39,0	1,9	1	2	2,50

Please check availability in current price and stock-list

D = heavy metal, E = carbide

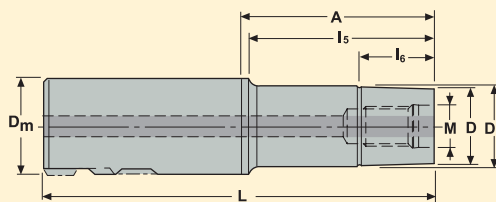

Weldon shank D_m	Connecting thread size	Part No.	Dimensions in mm						Balancing	
			A	L	I_5	I_6	D	D_3		
20	M10	BW02058211030	30	80	25	10	18,5	18,5	2	0,20
	M10	BW020582110102	102	152	97	20	18,5	18,5	2	0,40
25	M12	BW02558211245	45	101	40	20	23,0	23,5	2	0,40
	M12	BW025582112115	115	171	110	30	23,0	23,5	2	0,60
32	M16	BW03258211645	45	105	40	20	30,0	30,5	2	0,60

Please check availability in current price and stock-list

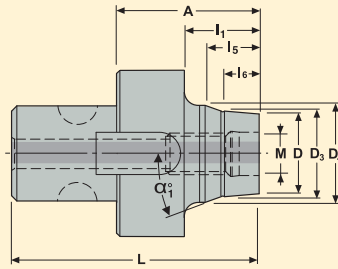

Graflex shank size	Connecting thread size	Part No.	Dimensions in mm								α_1°	Balancing	
			A	L	I ₁	I ₅	I ₆	D	D ₃	D ₄			
G5	M16	BM05058201640	40	70	20	15	10	30	31,7	35	18,25	2	0,60

Please check availability in current price and stock-list

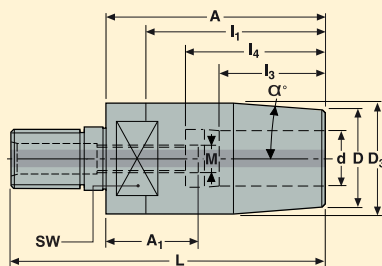

• Delivered with one stop screw

Connecting thread size	Shrinkfit d mm	Part No.	Dimensions in mm										α°	Balancing	KG
			A	L	I ₁	I ₃	I ₄	D	D ₃	M	A ₁ min-max	SW			
M16	6	BS01656030665	65	88	54	22	37,5	21	27	M5	29-39	26,0	4,5	2	0,3
	8	BS01656030865	65	88	54	26	37,5	21	27	M6	29-39	26,0	4,5	2	0,3
	10	BS01656031070	70	93	70	31	42,5	24	30	M8x1	29-39	26,0	4,5	2	0,4
	12	BS01656031270	70	93	70	34	42,5	24	30	M10x1	24-34	26,0	4,5	2	0,4

Spare Parts

For d	Stop screw
6	19BDR05165
8	19BDR06165
10	19BDR08165
12	19BDR10165

Please check availability in current price and stock-list
 For stop screw setting adapters, see page(s) 336

A complete range of modules, suitable for all machines and all machining operations

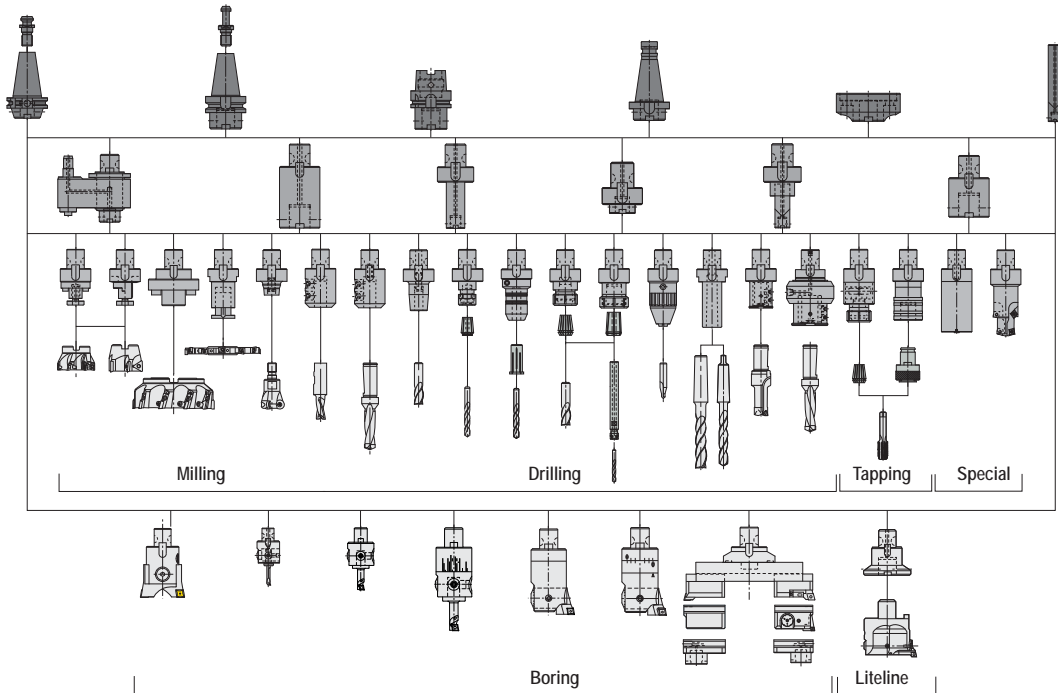

A modular system for flexibility and performance

Flexibility:

Tooling of variable lengths and diameters can rapidly be built together, when they are needed. Graflex® modules e.g. toolholders and boring heads, as well as cutting tools can be fitted on all types of machines, by the substitution of only the basic Graflex® arbor.

The Graflex® modules are suitable for milling, drilling, tapping, reaming and boring.

Performance:

The connection rigidity and precision, enables Graflex® assemblies to be used in similar machining conditions as the same sized Monobloc holders. The wide range of modules permits tooling dimensions closest to the required machining operation, for optimised cutting conditions.

All basic arbors, extensions and reducers, main toolholders and all boring heads have through coolant possibilities.



Power milling with Graflex® Modular System:
metal removal rate 432 cm³/min

The Graflex® connection (patented)

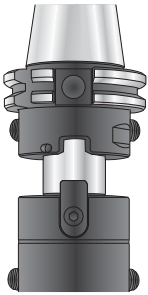

The long spigot and face connection, combined with EPB's production quality, masters all machining requirements, e.g. strength and precision in milling as well as in boring.

Radial access to the locking screws = easy handling.

High face contact pressure which can be enhanced by self-locking of the connection during machining = improved rigidity.

Graflex® is a registered trademark of Seco-EPB.

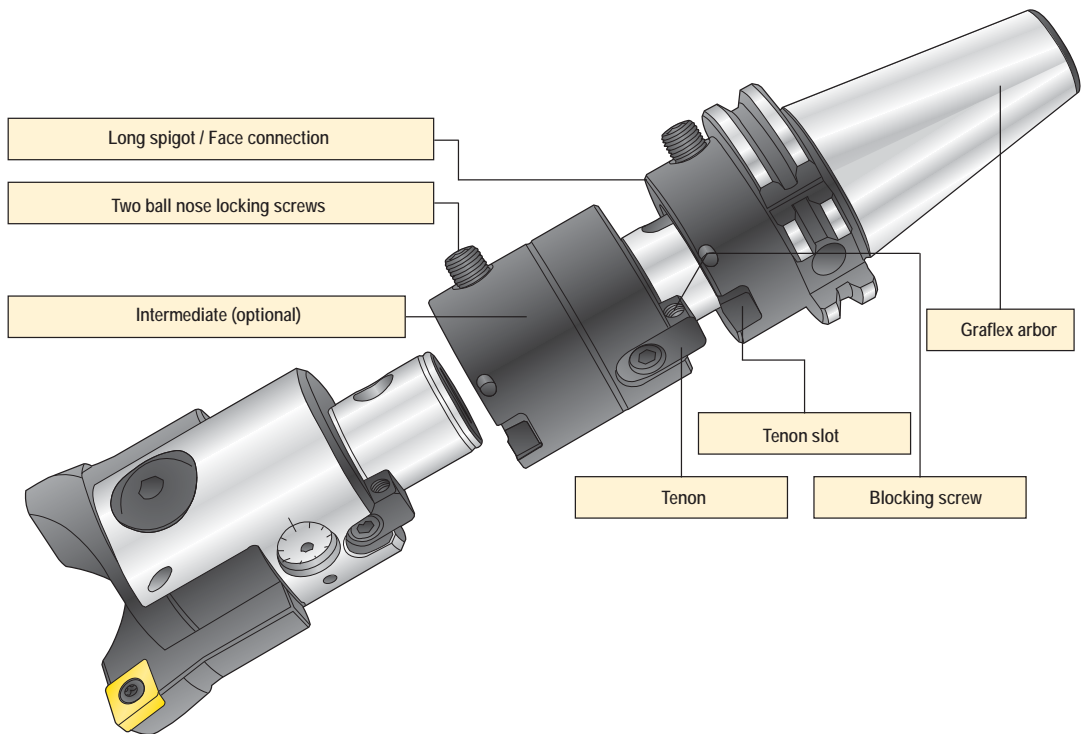

The alternative Graflex® connection using a split tenon is shown in Holemaking catalogue chapter Liteline.

Graflex® assembly procedure

1. Assemble the Graflex® arbor and module(s) using the tenon(s) for easy orientation. Tighten the ball nose locking screws ensuring that the left face of the tenon contacts the left face of the tenon slot (Drawings 1 & 2).
2. Strong machining torque e.g. during boring may create micro rotational movement of the spigot in relation to the bore, causing micro displacement of the ball nose screw's contact surfaces. This results in complementary self-locking of the connection, enhancing the system's rigidity (Drawing 3).
3. For operations involving intermittent cutting e.g. heavy milling, the blocking screw provided in the tenon can be tightened so as to avoid micro rotational movement and prevent self locking (Drawing 4).

Note: For 'optimised' assembly procedure, see next page.

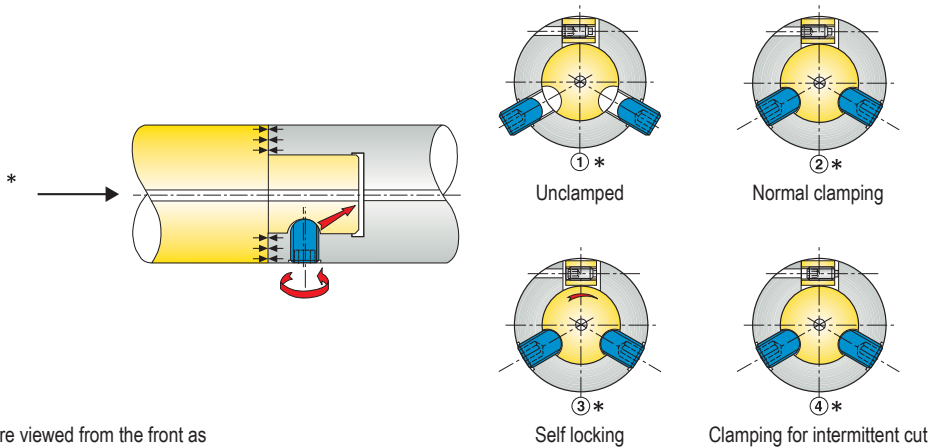

*Drawings 1, 2, 3 and 4 are viewed from the front as when normally assembled e.g. when using the Tool Boy assembly support.

'Optimised' Graflex® assembly procedure

left face

1. Clean the parts to be assembled and apply thin oxidation protection film.
2. Assemble the parts ensuring that the left face of the tenon contacts the left face of the tenon slot.
3. Lightly tighten screw A
4. Lightly tighten screw B

Normal clamping for continuous cut, e.g. boring, light duty milling

5. 'Torque' screw A (low values).
6. 'Torque' screw B (low values).

left face

5. 'Torque' the blocking screw C.
6. 'Torque' screw A (high values).
7. 'Torque' screw B (high values).
8. Double check the blocking screw tightening

Clamping for intermittent cut, e.g. interrupted boring, heavy duty milling

Graflex® connection, dimensions and recommended locking torques

The Graflex® connection is self locking, therefore it has a low requirement for checking that the locking torques have been applied. There is usually no requirement for torque control. The table shows the recommended torque ranges, prioritising assembly precision (low values) or rigidity/heavy duty (high values).

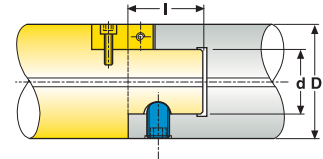

Graflex size	d mm	D mm	l mm	Recommended Graflex connection locking torques	
				Ball nose screws (A) & (B) Low values – High values	Tenon blocking screw (C)
0	08	16	12	1,5 - 2 Nm	–
1	11	20	13	1,5 - 2 Nm	–
2	14	25	16	2,5 - 4 Nm	–
3	18	32	20	5 - 8 Nm	0,4 Nm
4	22	40	24	13 - 20 Nm	0,7 Nm
5	28	50	30	17 - 25 Nm	2 Nm
6	36	63	40	23 - 35 Nm	4 Nm
7	46	90	50	40 - 60 Nm	8 Nm

Balancing of the Graflex® modules

All basic arbors except size 7 are fine balanced as standard for optimised compatibility with the boring heads used at high speeds. Graflex® intermediates and tool holders are pre-balanced.

In the Product pages, each Graflex® module balancing quality is indicated in the balancing column.

See also the 'Maximum speeds for Graflex® boring heads' Instruction pages.

Main Graflex® intermediates and adapters can be fine balanced on request, please enquire.

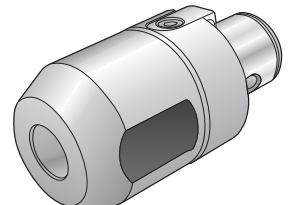

Graflex® connection, Accessories and Spare Parts

Accessories (locking keys) and spare parts (two ball nose screws kits or tenon kits) are grouped on page(s) 211.

Graflex® arbors – EPB 401, EPB 409

Graflex® basic arbors are available for all machine spindles type HSK, SA and Seco-Capto™ - Type EM...

Arbors are mainly available in 3 different lengths (short, medium and long).

All arbors except size 7 are fine balanced as standard, see balancing column in Product pages.

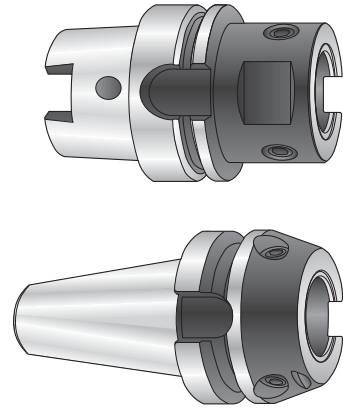

Graflex® adjustable arbors - Type ER...401...

Radial and angular adjustment enable the elimination of run-out of the cutting tool edge (e.g. reamer) in any Graflex® tool holder e.g. hydraulic chuck, Weldon, collet chuck.

Setting:

In order to adjust the cutting tool centre line, 4 screws (1) perform the angular adjustment and 4 screws (2) the radial adjustment. The assembly is locked by 4 screws (3).

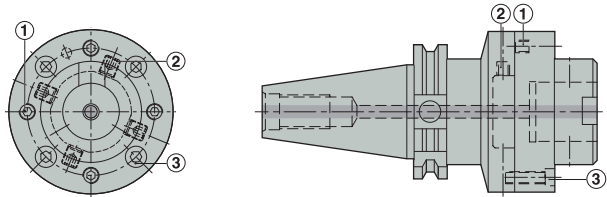

Graflex® flange mounts - Type M409...

Graflex® modules can be securely locked onto the machine spindle, without being influenced by the taper precision and the locking performance of the spindle.

Designed to suit to DIN 2079 spindle front ends.

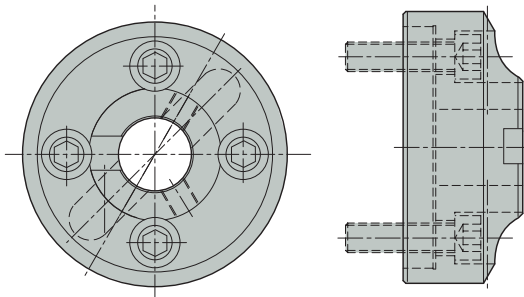

Graflex® extensions – EPB 402

Extensions have the same Graflex® size at the front (Graflex® bore) and at the back (Graflex® shank). They are mainly available in different lengths: short, medium and long.

New: Extra long extensions are particularly suitable for creating optimum assemblies for Perfomax® modular drill heads SD 600.

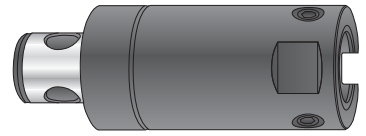

Graflex® reducers – EPB 403

Reducers have a smaller Graflex® size at the front (Graflex® bore) in relation to the back (Graflex® shank).

Long Graflex® reducers

When used with a Graflex® boring head, long Graflex® reducers give boring length to diameter ratio of approx. 4xD.

Extra long Graflex® reducers, carbide type – Type M403...C...

The extension section is manufactured from carbide.
The extra long reducers to be used with fine boring heads for boring length to diameter ratio of approx. 7xD.
Very rigid but brittle extensions, not suitable for heavy duty applications.
Maximum boring lengths are listed in the Product pages (lu).
Other lengths can be supplied on request, please enquire.

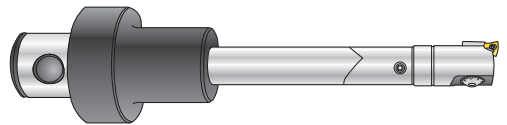
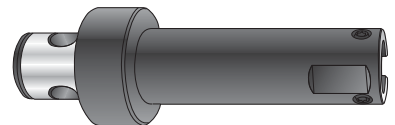
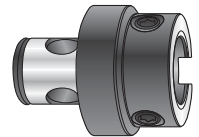

Graflex® enlargers - Part No. M40356 and M40367

The enlargers enable the mounting of modules with large Graflex® connection size 6 or 7 on arbors with maximum connection size 5 or 6.

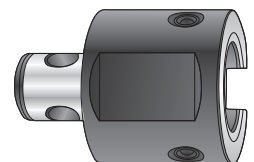

Graflex® cylindrical extensions – EPB 401

Cylindrical Graflex® extensions, steel type

The cylindrical shank, with tolerance h5, can be held in any suitable holding system, including Shrinkfit holders.
 Suitable for long rough or fine boring.
 Maximum boring depths are listed in the Product pages (lu).



These extensions have a 'through' coolant channel.

Cylindrical Graflex® extensions, carbide type M401...C

Graflex® extensions with cylindrical shank in carbide are suitable for fine boring length to diameter ratios of up to approx. 9xD
 The cylindrical shank with tolerance h5 can be held in Shrinkfit holders, or any other suitable holding system.
 Very rigid but brittle extensions, not suitable for heavy duty applications.
 Maximum boring depths are listed in the Product pages (lu).

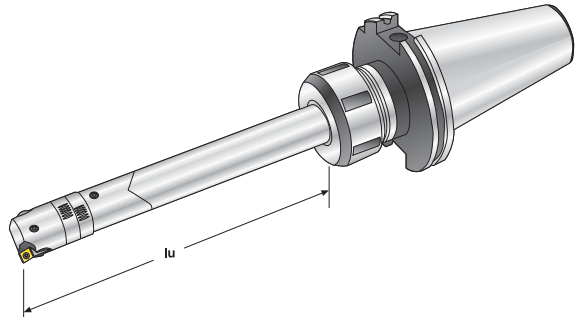

These extensions have a 'through' coolant channel.

Graflex® tool holders – EPB 5525, EPB 584, etc

Graflex® holders are available with main front end types similar to Monobloc holders. Adjustable drill holders and rotary coolant inducers are only available with a Graflex® connection for high flexibility.

Note: Graflex® adapters with Combimaster front end, see Combimaster chapter.

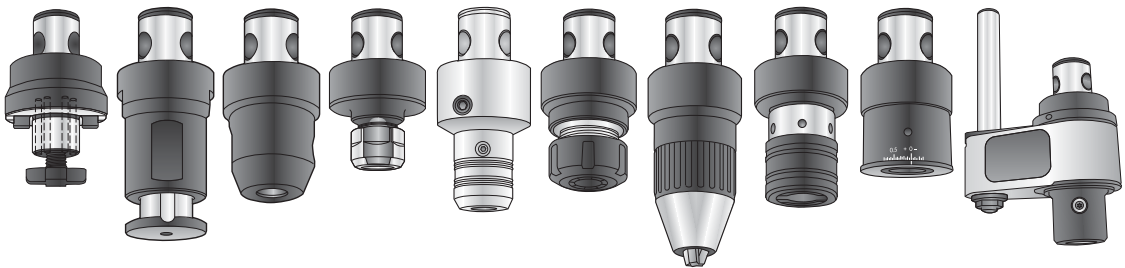

EPB 401 - Graflex® arbors

HSK-A/ISO 12164-1-A

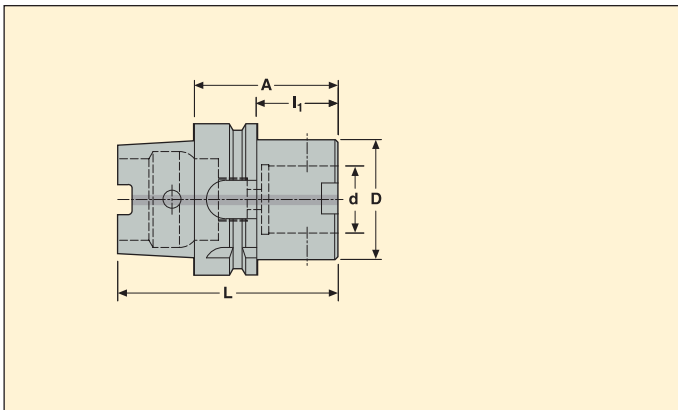

Taper	Graflex bore		Part No.	Dimensions in mm				Balancing	KG	
	Size	d mm		A	L	I ₁	D			
HSK-A40	G2	14	EM93024011440	40	60	20	25	1	0,55	
HSK-A50	G3	18	EM93034011850	50	75	24	32	1	0,49	
	G5	28	EM93034012870	70	95	44	50	1	1,87	
HSK-A63	G2	14	EM93044011445	45	77	19	25	1	1,52	
	G4	22	EM93044012255	55	87	29	40	1	1,98	
	G5	28	EM93044012860	60	92	34	50	1	2,20	
	G5	28	EM930440128100	100	132	74	50	1	3,52	
	G5	28	EM930440128140	140	172	114	50	1	4,96	
	G6	36	EM93044013670	70	102	44	63	1	2,75	
	G6	36	EM930440136120	120	152	94	63	1	4,96	
HSK-A100	G3	18	EM93064011855	55	105	26	32	1	4,18	
	G4	22	EM93064012260	60	110	31	40	1	4,62	
	G5	28	EM93064012865	65	115	36	50	1	5,07	
	G5	28	EM930640128110	110	160	81	50	1	6,61	
	G5	28	EM930640128150	150	200	121	50	1	7,93	
	G6	36	EM93064013675	75	125	46	63	1	5,73	
	G6	36	EM930640136120	120	170	91	63	1	9,92	
	G6	36	EM930640136160	160	210	131	63	1	10,80	
	G7	46	EM93064014685	85	135	56	90	2	9,25	
	G7	46	EM930640146160	160	210	131	90	2	13,20	

Please check availability in current price and stock-list
 For HSK sealing plugs, coolant tubes and tube spanners, see page(s) 287

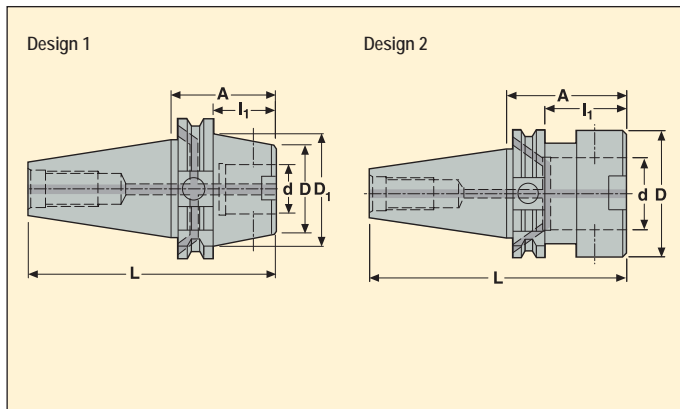



Taper	Graflex bore		Part No.	Dimensions in mm					Design	Balancing	KG
	Size	d mm		A	L	I ₁	D	D ₁			
DIN40 ADB	G1	11	EM34694011190	90	158,4	70,9	20	-	2	1	0,94
	G2	14	EM34694011435	35	103,4	15,9	25	-	2	1	0,83
	G2	14	EM34694011490	90	158,4	70,9	25	-	2	1	1,02
	G3	18	EM34694011835	35	103,4	15,9	32	50	1	1	0,91
	G3	18	EM346940118100	100	168,4	80,9	32	-	2	1	1,22
	G4	22	EM34694012235	35	103,4	15,9	40	50	1	1	0,92
	G4	22	EM346940122100	100	168,4	80,9	40	-	2	1	1,44
	G5	28	EM34694012840	40	108,4	20,9	50	-	2	1	0,93
	G5	28	EM34694012880	80	148,4	60,9	50	-	2	1	1,50
	G5	28	EM346940128120	120	188,4	100,9	50	-	2	1	2,08
	G6	36	EM34694013660	60	128,4	40,9	63	-	2	1	1,24
	G6	36	EM346940136120	120	188,4	100,9	63	-	2	1	2,65
DIN50 ADB	G2	14	EM347140114100	100	201,7	80,9	25	-	2	1	2,80
	G3	18	EM34714011835	35	136,7	15,9	32	-	2	1	2,67
	G3	18	EM347140118110	110	211,7	90,9	32	-	2	1	3,00
	G4	22	EM34714012235	35	136,7	15,9	40	80	1	1	2,88
	G4	22	EM347140122120	120	221,7	100,9	40	-	2	1	3,36
	G5	28	EM34714012840	40	141,7	20,9	50	-	2	1	2,75
	G5	28	EM347140128100	100	201,7	80,9	50	-	2	1	3,56
	G5	28	EM347140128140	140	241,7	120,9	50	-	2	1	4,08
	G6	36	EM34714013645	45	146,7	25,9	63	-	2	1	2,88
	G6	36	EM347140136100	100	201,7	80,9	63	-	2	1	4,08
	G6	36	EM347140136140	140	241,7	120,9	63	-	2	1	4,99
	G7	46	EM34714014650	50	151,7	30,9	90	-	2	2	3,23
	G7	46	EM347140146120	120	221,7	100,9	90	-	2	2	6,48
	G7	46	EM347140146200	200	301,7	180,9	90	-	2	2	10,30

Please check availability in current price and stock-list

EPB 401 – Graflex® arbors

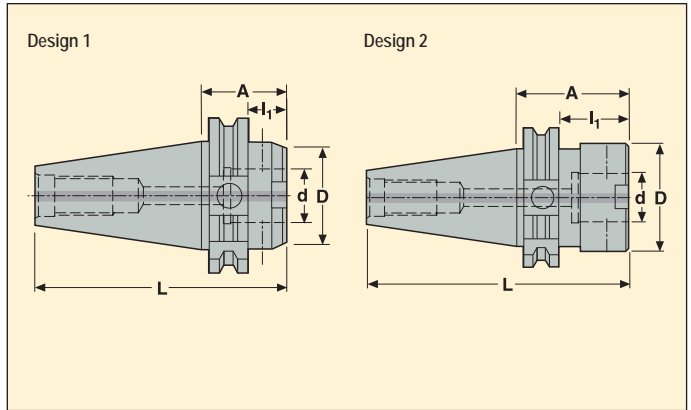
DIN 69871-AD/ CAT Metric Compatible



Taper	Graflex bore		Part No.	Dimensions in mm				Design	Balancing	
	Size	d mm		A	L	I ₁	D			
DIN40 AD/ CAT40	G6	36	EM44664013660	60	128,4	40,9	63	2	1	1,22
	G5	28	EM44684012840	40	141,7	20,9	50	1	1	3,00
	G6	36	EM44684013645	45	146,7	25,9	63	1	1	2,98
	G7	46	EM44684014665	65	166,7	45,9	90	2	2	3,74
DIN50 AD/ CAT50										

Please check availability in current price and stock-list

EPB 401 – Graflex® arbors

BT JIS B 6339-AD

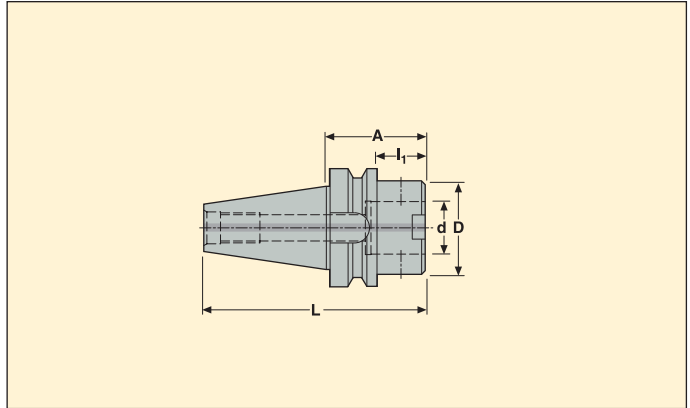

Taper	Graflex bore		Part No.	Dimensions in mm				Balancing	KG
	Size	d mm		A	L	I ₁	D		
BT30 AD	G3	18	EM40404011835	35	83,4	13	32	1	0,41
	G5	28	EM40404012850	50	98,4	25	50	1	0,62

Please check availability in current price and stock-list

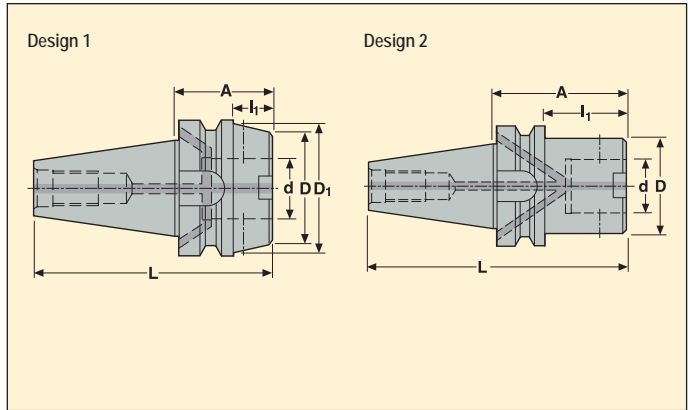

Taper	Graflex bore		Part No.	Dimensions in mm					Design	Balancing	KG	
	Size	d mm		A	L	I ₁	D	D ₁				
BT40 ADB	G1	11	EM34144011190	90	155,4	63	20	–	2	1	1,06	
	G2	14	EM34144011440	40	105,4	13	25	–	2	1	0,98	
	G2	14	EM34144011490	90	155,4	63	25	–	2	1	1,15	
	G3	18	EM34144011840	40	105,4	13	32	62	1	1	1,07	
	G3	18	EM341440118100	100	165,4	73	32	–	2	1	1,31	
	G4	22	EM34144012245	45	110,4	18	40	62	1	1	1,14	
	G4	22	EM341440122100	100	165,4	73	40	–	2	1	1,54	
	G5	28	EM34144012845	45	110,4	18	50	62	1	1	1,12	
	G5	28	EM34144012880	80	145,4	53	50	–	2	1	1,54	
	G5	28	EM341440128120	120	185,4	93	50	–	2	1	2,12	
BT50 ADB	G6	36	EM34144013650	50	115,4	–	63	–	2	1	1,13	
	G6	36	EM341440136120	120	185,4	–	63	–	2	1	2,78	
	G2	14	EM341640114110	110	211,8	72	25	–	2	1	3,70	
	G3	18	EM34164011845	45	146,8	7	32	70	1	1	3,58	
	G3	18	EM341640118120	120	221,8	82	32	–	2	1	3,90	
	G4	22	EM34164012250	50	151,8	12	40	70	1	1	3,66	
	G4	22	EM341640122140	140	241,8	102	40	–	2	1	4,36	
	G5	28	EM34164012855	55	156,8	17	50	70	1	1	3,97	
	G5	28	EM341640128100	100	201,8	62	50	–	2	1	4,22	
	G5	28	EM341640128140	140	241,8	102	50	–	2	1	4,80	
	G6	36	EM34164013663	63	164,8	25	63	98	1	1	4,20	
	G6	36	EM341640136100	100	201,8	62	63	–	2	1	4,60	
	G6	36	EM341640136140	140	241,8	102	63	–	2	1	5,54	
	G7	46	EM34164014665	65	166,8	27	90	98	1	2	4,30	
	G7	46	EM341640146120	120	221,8	82	90	–	2	2	6,80	
	G7	46	EM341640146200	200	301,8	162	90	–	2	2	10,70	

Please check availability in current price and stock-list

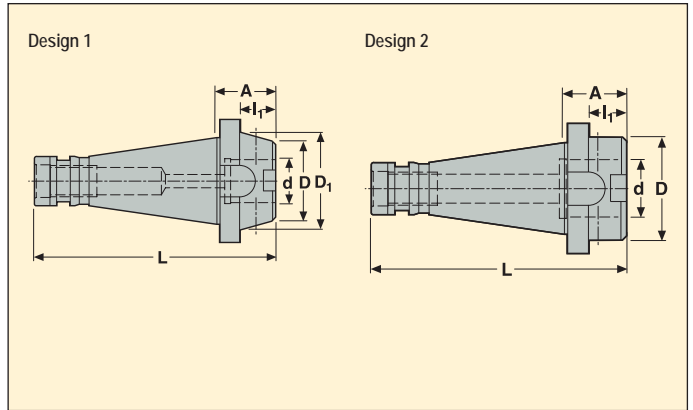

Taper	Graflex bore		Part No.	Dimensions in mm					Design	Balancing	KG
	Size	d mm		A	L	I ₁	D	D ₁			
DIN(2080)40	G6	36	EM00404013650	50	143,4	-	63	-	2	2	1,27
DIN(2080)50	G4	22	EM00504012230	30	156,8	14,8	40	78	1	2	2,83
	G5	28	EM00504012835	35	161,8	19,8	50	78	1	2	2,94
	G6	36	EM00504013640	40	166,8	24,8	63	-	2	2	2,82
	G7	46	EM00504014645	45	171,8	29,8	90	-	2	2	3,34

Please check availability in current price and stock-list

EPB 401 – Graflex® adjustable arbors

DIN 69871-AD and BT JIS B 6339-AD

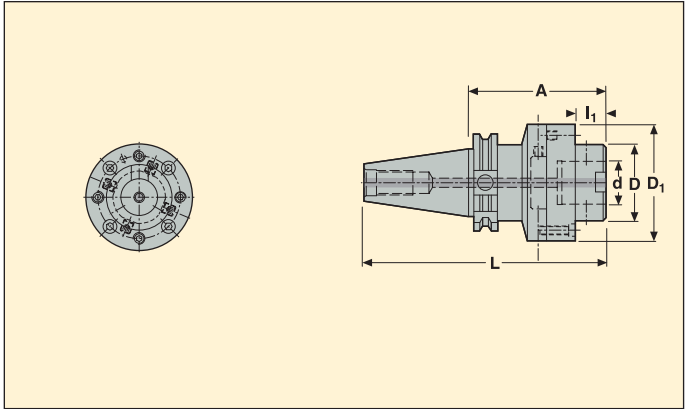

- Enable radial and angular adjustment

Taper	Graflex bore		Part No.	Dimensions in mm					Balancing	
	Size	d mm		A	L	I ₁	D	D ₁		
DIN40 AD	G5	28	ER44694012890	90	158,4	20	50	76	2	3,52
	G6	36	ER447140136100	100	201,7	25	63	95	2	9,03
BT40 AD	G5	28	ER40414012890	90	155,4	20	50	76	2	3,74
	G6	36	ER576640136100	100	201,7	25	63	95	2	9,92
BT50 AD	G5	28								
	G6	36								
BT50 AD										

Please check availability in current price and stock-list



- Suitable for mounting on DIN 2079 type spindle front ends

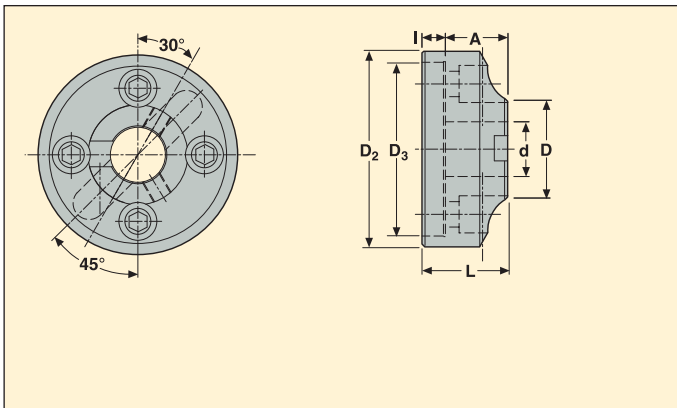

Spindle size	Graflex bore		Part No.	Dimensions in mm						Balancing	
	Size	d mm		A	D	D ₂	D ₃	L	I		
SA40	G6	36	M4094036	42	63	100	88,88	54	12	–	1,74
SA50	G7	46	M4095046	50	90	150	128,57	65	15	–	4,97

Please check availability in current price and stock-list

EPB 402 – Graflex® extensions

Graflex®

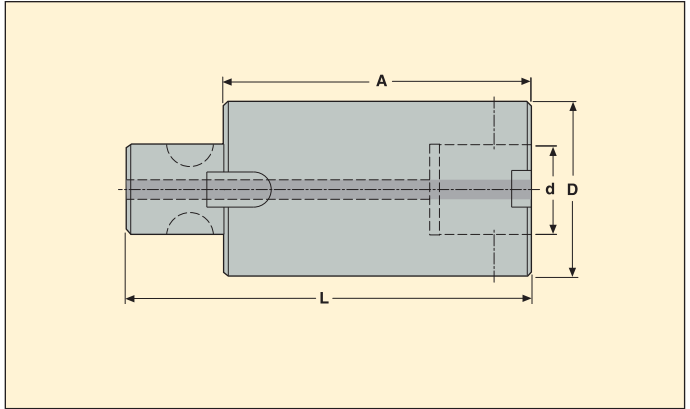



Graflex bore		Part No.	Dimensions in mm			Balancing	
Size	d mm		A	L	D		
G0	8	M402000	30	42	16	2	0,05
	8	M402001	50	62	16	2	0,08
G1	11	M402110	30	43	20	2	0,07
	11	M402111	50	63	20	2	0,12
G2	14	M402220	30	46	25	2	0,11
	14	M402221	50	66	25	2	0,18
G3	18	M402330	40	60	32	2	0,24
	18	M402331	60	80	32	2	0,36
G4	22	M402440	40	64	40	2	0,37
	22	M402441	60	84	40	2	0,57
	22	M402444	200	224	40	2	1,95
G5	28	M402550	50	80	50	2	0,72
	28	M402551	75	105	50	2	1,12
	28	M402552	100	130	50	2	1,48
	28	M402554	250	280	50	2	3,90
G6	36	M402660	60	100	63	2	1,38
	36	M402661	90	130	63	2	2,10
	36	M402662	120	160	63	2	2,82
	36	M402664	300	340	63	2	7,20
G7	46	M402770	60	110	90	-	2,83
	46	M402771	90	140	90	-	4,03
	46	M402772	120	170	90	-	5,78
	46	M402774	300	350	90	-	14,60

Please check availability in current price and stock-list

EPB 403 – Graflex® reducers

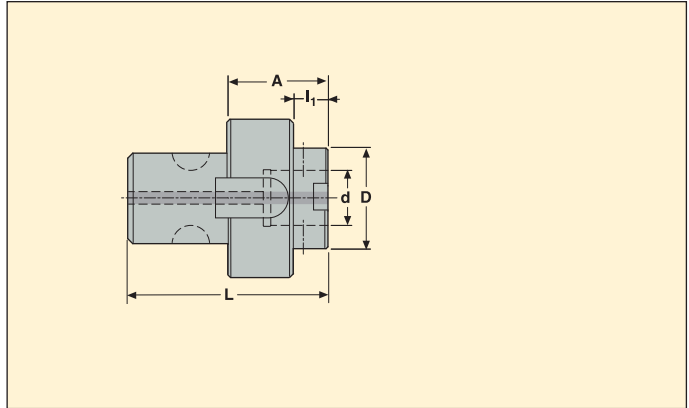
Graflex®



Graflex bore		Part No.	Dimensions in mm				Balancing	 KG
Size	d mm		A	L	I ₁	D		
G1	8	M40310	30	43	22	16	2	0,06
G2	8	M40320	30	46	19	16	2	0,08
	11	M40321	30	46	19	20	2	0,10
G3	8	M40330	30	50	16	16	2	0,15
	11	M40331	30	50	16	20	2	0,15
	14	M40332	30	50	16	25	2	0,16
G4	11	M40341	30	54	13	20	2	0,25
	14	M40342	30	54	13	25	2	0,27
	18	M40343	30	54	13	32	2	0,27
G5	8	M40350	40	70	20	16	2	0,47
	11	M40351	40	70	20	20	2	0,49
	14	M40352	40	70	20	25	2	0,49
	18	M40353	40	70	20	32	2	0,52
	22	M40354	40	70	20	40	2	0,55
G6	11	M40361	40	80	14	20	2	0,96
	18	M40363	40	80	14	32	2	0,98
	22	M40364	40	80	14	40	2	0,97
	28	M40365	45	85	19	50	2	1,04
G7	28	M40375	50	100	24	50	–	2,08
	36	M40376	55	105	29	63	–	2,23

Please check availability in current price and stock-list

EPB 403 – Graflex® long reducers

Graflex®

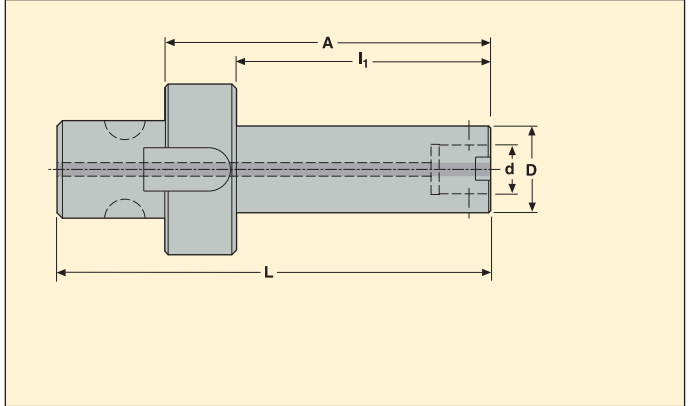

• For extra long reducers, see following page

Graflex bore		Part No.	Dimensions in mm				Balancing	
Size	d mm		A	L	I ₁	D		
G5	8	M40350070	70	100	50	16	2	0,51
	11	M40351080	80	110	60	20	2	0,57
	14	M40352100	100	130	80	25	2	0,71
	18	M40353120	120	150	100	32	2	1,02
	22	M40354150	150	180	130	40	2	1,62
G6	11	M40361090	90	130	64	20	2	1,08
	14	M40362110	110	150	84	25	2	1,23
	18	M40363120	120	160	94	32	2	1,46
	22	M40364150	150	190	124	40	2	2,07
	28	M40365190	190	230	164	50	2	3,20
G7	36	M40376230	230	280	204	63	–	6,40

Please check availability in current price and stock-list

EPB 403 – Graflex® extra long reducers, carbide

Graflex®

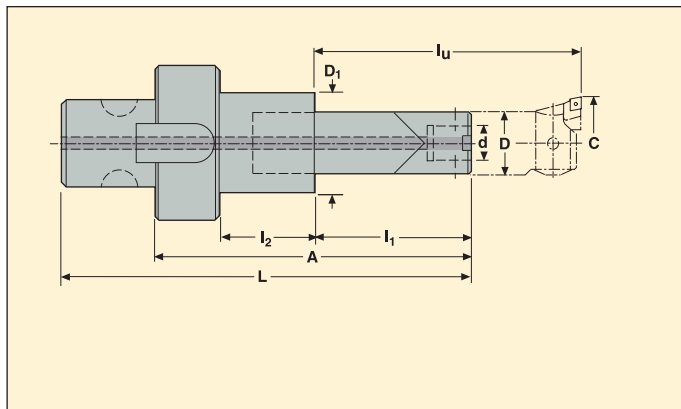

- The extension section is manufactured from carbide
- Suitable for fine boring length up to 'lu' with fitted boring head type A780 or A790

Graflex bore		Capacity C Ø mm	Part No.	Dimensions in mm							Balancing	KG
Size	d mm			A	L	l ₁	l ₂	D	D ₁	l _u		
G0	8	18-23.5	M40350C150	150	180	95	35	16	32	130	-	1,00
G1	11	23-31	M40351C180	180	210	120	40	20	36	160	-	1,33
G2	14	30-40	M40352C220	220	250	155	45	25	41	200	-	2,01

Please check availability in current price and stock-list

EPB 403 – Graflex® enlargers

Graflex®

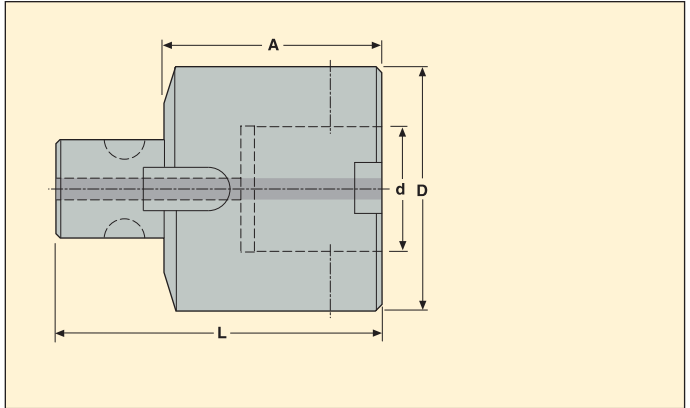

Graflex bore		Part No.	Dimensions in mm			Balancing	
Size	d mm		A	L	D		
G6	36	M40356	55	85	63	2	1,08
	46	M40367	80	120	90	-	3,46
G7							

Please check availability in current price and stock-list

EPB 401 - Graflex® extensions, cylindrical, steel

Cylindrical

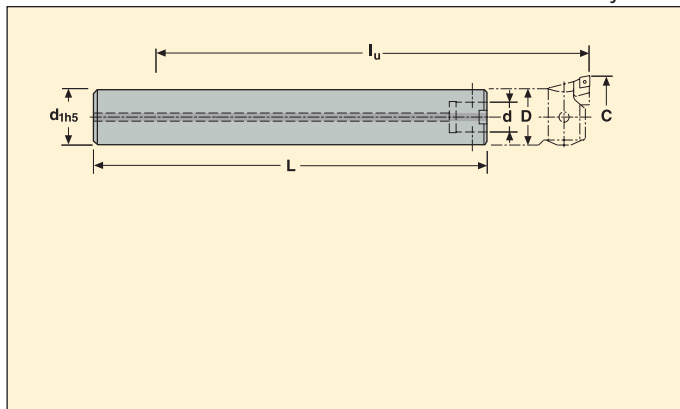

- Suitable for boring length up to l_u with fitted boring head type A780 or A790
- Cylindrical shank d_{h5} with tolerance h5, compatible for Shrinkfit

Shank d_{h5}	Graflex bore		Capacity C Ø mm	Part No.	Dimensions in mm			Balancing	 KG
	Size	d mm			L	D	l_u		
14	G0	8	15-18.5	M4011408	120	14	110	-	0,12
16	G0	8	18-23.5	M4011608	120	16	137	-	0,20
20	G1	11	23-31	M4012011	150	20	140	-	0,33
25	G2	14	30-40	M4012514	150	25	139	-	0,53
32	G3	18	39-51	M4013218	150	32	155	-	0,87

Please check availability in current price and stock-list

EPB 401 – Graflex® extensions, cylindrical, carbide

Cylindrical

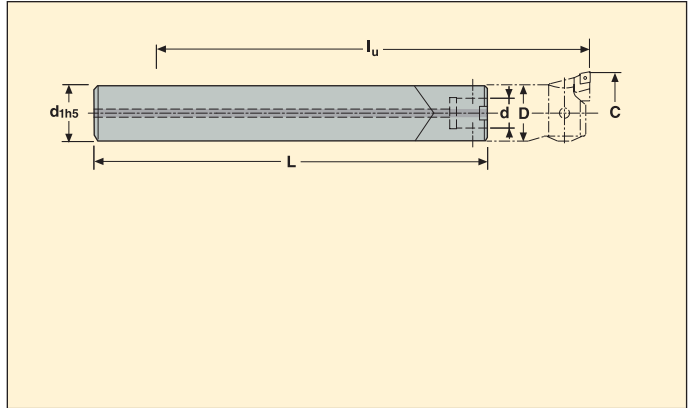

- Suitable for fine boring length up to 'lu' with fitted boring head type A780 or A790
- Cylindrical shank d₁h5 with tolerance h5, compatible for Shrinkfit

Shank d ₁ h5	Graflex bore		Capacity C ∅ mm	Part No.	Dimensions in mm			Balancing	
	Size	d mm			L	D	l _u		
14	G0	8	15-18.5	M4011408C	150	14	140	-	0,31
16	G0	8	18-23.5	M4011608C	173	16	160	-	0,47
20	G1	11	23-31	M4012011C	210	20	200	-	0,89
25	G2	14	30-40	M4012514C	261	25	250	-	1,71
32	G3	18	39-51	M4013218C	315	32	320	-	3,44

Please check availability in current price and stock-list

EPB 5525/5524 – Shell mill holders, with through coolant channels

Graflex®



- With coolant supply channels through the spigot

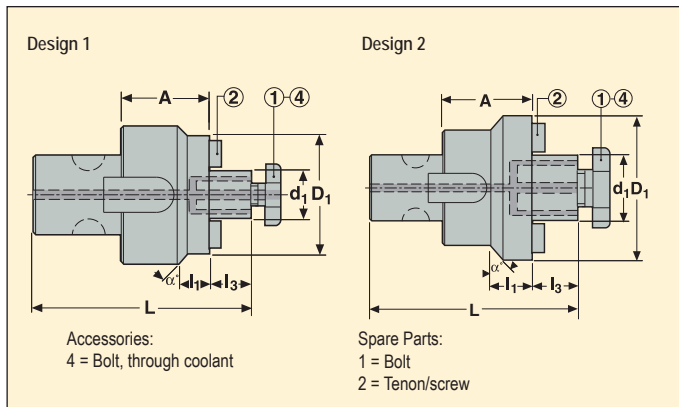

Graflex shank size***	d ₁ mm	Part No.	Dimensions in mm					*	**	Design	α°	Balancing	
			A	D ₁	L	I ₁	I ₃						
G3	16	M55251816	25	32	62	–	17	*	1	–	2	0,19	
G4R	16	M55252216R	25	38	66	–	17		1	–	2	0,31	
G4	22	M55252222	25	48	68	19	19	*	2	45	2	0,44	
G5	16	M55252816	32	38	79	6	17		1	45	2	0,59	
G5R	22	M55252822R	32	48	81	–	19	*	1	–	2	0,64	
G5	27	M55252827	32	60	83	24	21	* **	2	45	2	0,86	
G5R	27	M55242827R	32	48	83	–	21	* **	1	–	2	0,68	
G6	22	M55253622	40	48	80	6,5	19		1	45	2	1,20	
G6	22	M55253622120	120	48	160	81	19		1	30	2	2,36	
G6R	27	M55253627R	40	60	80	–	21	*	1	–	2	1,27	
G6R	27	M55253627120R	120	60	160	–	21	*	1	–	2	3,00	
G6	32	M55253632	40	78	80	14	24	*	2	30	2	1,59	
G7	27	M55254627R	40	60	111	5	21		1	45	2	2,00	
G7	32	M55254632	40	78	114	8	24		1	45	2	2,58	
G7R	32	M55254632R	40	78	114	–	24	*	1	–	2	2,25	

* Suitable for long wall milling and plunging. ** Diameter D₁ on type 5524 is smaller than on type 5525

*** (R) = D reduced compared to the standard Graflex® D

Accessories

For Shank/ d ₁	Bolt, through coolant	Spanner
3/16	5801608L	5811608
4/16, 5/16	5801608L	5811608
4/22, 5/22, 6/22	5802210L	5812210
5/27/5524	5802712L	5812712
5/27/5525	5802712L	5812712
6/27, 7/27	5802712L	5812712
6/32, 7/32	5803216L	5813216

Spare Parts

For Shank/ d ₁	Bolt	Screw	Tenon
3/16	5801608	950D0308	16C116
4/16, 5/16	5801608	950D0312	16C10810164
4/22, 5/22, 6/22	5802210	950D0416	16C11012206
5/27/5524	5802712	951D0512	16C127
5/27/5525	5802712	951D0516	16C11214243
6/27, 7/27	5802712	951D0516	16C11214243
6/32, 7/32	5803216	951D0516	16C2141421

Please check availability in current price and stock-list

EPB 553 – Combi shell mill holders - DIN 6358

Graflex®



- With removable driving ring

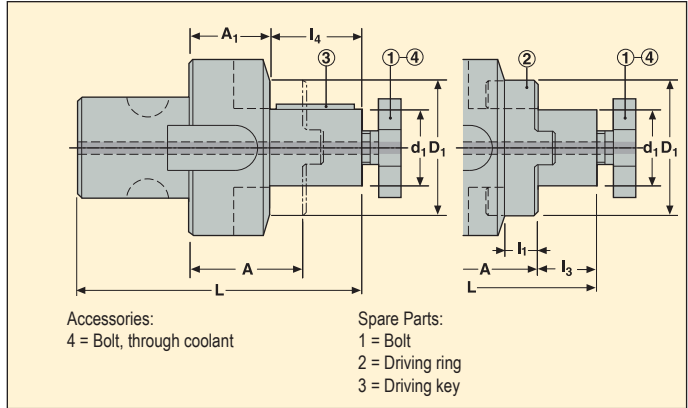

d ₁ mm	Part No.	Dimensions in mm							Balancing	
		A	A ₁	D ₁	L	I ₁	I ₃	I ₄		
16	M5532816	32	22	32	79	10	17	27	-	0,49
22	M5532822	32	20	40	81	12	19	31	-	0,61
27	M5533627	40	28	48	101	12	21	33	-	1,10
32	M5533632	40	26	58	104	14	24	38	-	1,16

Accessories

For d ₁	Bolt, through coolant	Spanner
16	5801608L	5811608
22	5802210L	5812210
27	5802712L	5812712
32	5803216L	5813216

Spare Parts

For d ₁	Bolt	Driving key	Driving ring
16	5801608	04C216	58316
22	5802210	04C222	58322
27	5802712	04C227	58327
32	5803216	04C232	58332

Please check availability in current price and stock-list

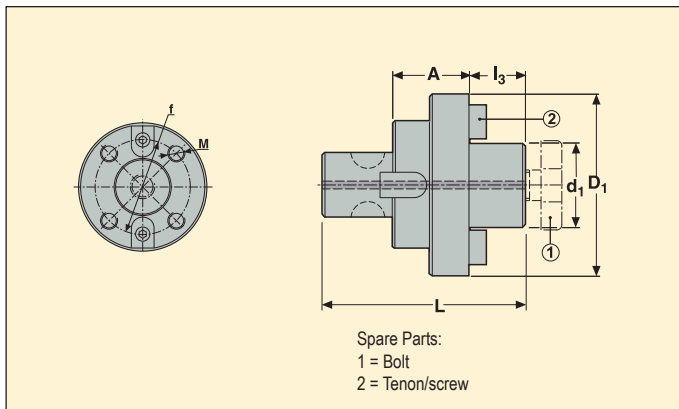

Graflex shank size	d ₁ mm	Part No.	Dimensions in mm					M mm	Balancing	
			A	D ₁	L	I ₃	f			
G7	40	M5694640	46	89	123	27	66,7	M12	2	3,10
G7	60	M5694660	54	129	144	40	101,6	M16	2	5,50

d₁ 40, with additional central thread and bolt according to ISO 3937

Accessories

For d ₁	Spanner
40	5814020
60	-

Spare Parts

For d ₁	Bolt	Screw	Tenon
40	5804020	951D0616	16C34040
60	-	951D1225	16C35060

Please check availability in current price and stock-list

EPB 5656 – Disc mill holders

Graflex®



- With adjustable slide rod
- Best suitable for Seco disc mill cutters Type A

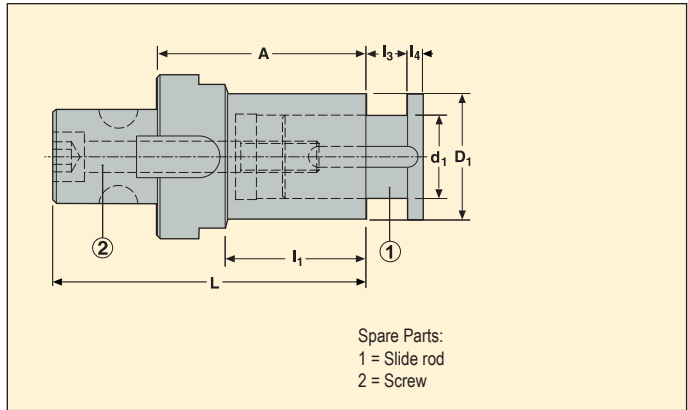

Graflex shank size***	d ₁ mm	Part No.	Dimensions in mm						Balancing	
			A	D ₁	L	I ₁	I ₃	I ₄		
G3	16	M56561816	50	28	70	36	10	3	2	0,30
G4	22	M56562222	60	35	84	43	12	4	2	0,56
G5	27	M56562827	65	42	95	45	14	5	2	0,95
	32	M5656283212	80	48	110	60	24	6	2	1,32
G6	32	M5656363212	85	48	125	59	24	6	2	1,80
	40	M56563640	110	58	150	84	30	7	2	2,68
G7	50	M56564650	130	72	180	104	32	8	–	5,30
	60	M56564660	150	90	200	124	40	8	–	8,18

Spare Parts

For holder	Screw	Slide rod
M56561816	950D0650	565616
M56562222	950D0860	565622
M56562827	950D1070	565627
M5656283212	950D1290	56563202
M5656363212	950D12100	56563202
M56563640	950D16110	565640
M56564650	950D16120	565650
M56564660	950D16120	565660

Please check availability in current price and stock-list

EPB 584 – Side lock holders, Weldon - DIN 1835 Form B/ DIN 6535 Form HB

Graflex®



- Weldon d 16, 20, 25, 32 and 40 with ground face (Seco-Weldon compatible)

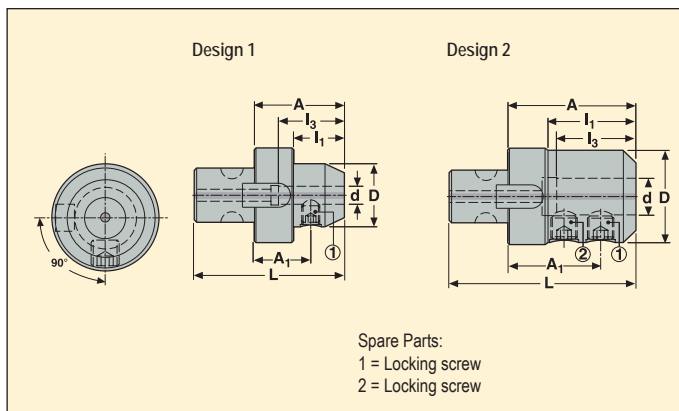

Graflex shank size	d mm	Part No.	Dimensions in mm						Design	Balancing	KG
			A	D	L	I ₁	I ₃	A ₁			
G5	6	M5842806	45	25	75	25	27	27,5	1	2	0,51
	8	M5842808	45	28	75	25	30	27,5	1	2	0,52
	10	M5842810	55	35	85	35	36	35,5	1	2	0,65
	12	M5842812	60	42	90	40	43	38,0	1	2	0,79
	14	M5842814	60	44	90	40	43	38,0	1	2	0,81
	16	M5842816	65	48	95	45	46	41,5	1	2	0,94
	18	M5842818	65	50	95	45	46	41,5	1	2	0,96
	20	M5842820	65	52	95	45	48	40,5	1	2	1,00
G6	10	M5843610	55	35	95	29	36	35,5	1	2	1,10
	12	M5843612	60	42	100	34	43	38,0	1	2	1,20
	16	M5843616	65	48	105	39	46	41,5	1	2	1,34
	18	M5843618	65	50	105	39	46	41,5	1	2	1,37
	20	M5843620	65	52	105	39	48	40,5	1	2	1,37
	25	M5843625	80	63	120	–	54	56,5	2	2	1,95
	32	M5843632	80	72	120	54	58	56,5	2	2	2,15
G7	32	M5844632	80	72	130	54	58	56,5	2	–	3,10
	40	M5844640	100	80	150	74	68	70,5	2	–	4,00

Spare Parts

For d	Locking screw 1	Locking screw 2
6	951C0610	–
8	951C0810	–
10	951C1012	–
12-14	951C1216	–
16-18	951C1416	–
20	951C1616	–
25	951C1820	951C1820
32/ G6	951C2020	951C2017
32/ G7	951C2020	–
40	951C2020	–

Please check availability in current price and stock-list



- Whistle Notch d 16, 20, 25 and 32 with ground face

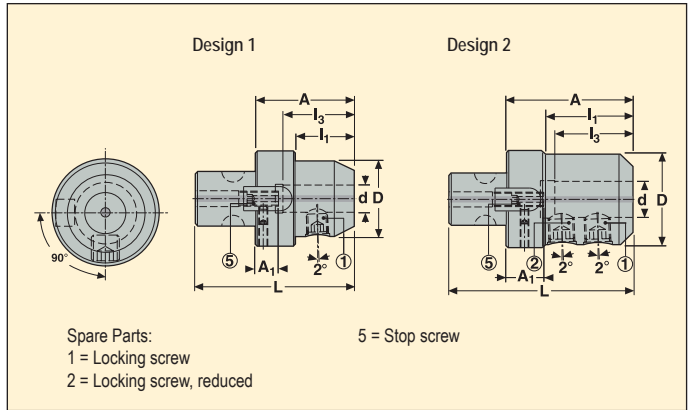

Graflex shank size	d mm	Part No.	Dimensions in mm						Design	Balancing	KG
			A	D	L	I ₁	I ₃	A ₁ min-max			
G5	20	M58432820	65	52	95	45	49	11-25	1	2	0,98
G6	25	M58433625	80	63	120	–	54	16-24	2	2	1,89
	32	M58433632	80	72	120	54	58	17-22	2	2	2,10

Spare Parts

For d	Locking screw 1	Locking screw 2	Stop screw
20	951C1616	–	19TLR1030
25	951C1820	951C1820	19TLR1030
32	951C2020	951C2017	19TLR1030

Please check availability in current price and stock-list

EPB 5603 – Shrinkfit holders, DIN type

Graflex®



• Delivered with one stop screw

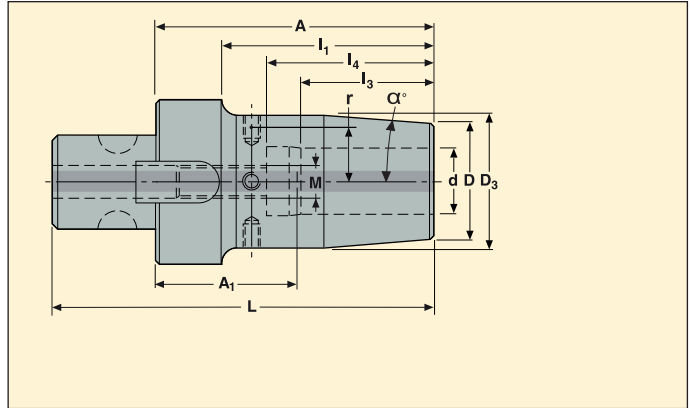

Graflex shank size	d mm	Part No.	Dimensions in mm								M mm	α°	r mm	Balancing	KG
			A	D	D ₃	L	I ₁	I ₃	I ₄	A ₁ min-max					
G5	6	BM050560306100	100	21	27	130	80	22	37,5	64-74	M5	4,5	10,5	2	0,80
	8	BM050560308100	100	21	27	130	80	26	37,5	64-74	M6	4,5	10,5	2	0,80
	10	BM050560310110	110	24	32	140	90	31	42,5	69-79	M8x1	4,5	13,0	2	0,88
	12	BM050560312115	115	24	32	145	95	34	47,5	69-79	M10x1	4,5	13,0	2	0,89
G6	16	BM060560316125	125	27	34	165	99	39	50,5	76-86	M12x1	4,5	14,0	2	1,50
	20	BM060560320125	125	33	42	165	99	41	52,5	74-84	M16x1	4,5	18,0	2	1,68

For Shrinkfit extensions, see page(s) 294

Accessories

For d	Balancing screws
6	90ZQ01
8	90ZQ01
10	90ZQ01
12	90ZQ01
16	90ZQ01
20	90ZQ01

Spare Parts

For d	Stop screw
6	19BDR05165
8	19BDR06165
10	19BDR08165
12	19BDR10165
16	19BDR12165
20	19BDR16165

Please check availability in current price and stock-list
 For stop screw setting adapters, see page(s) 336

EPB 5672 – High precision collet chucks

Graflex®

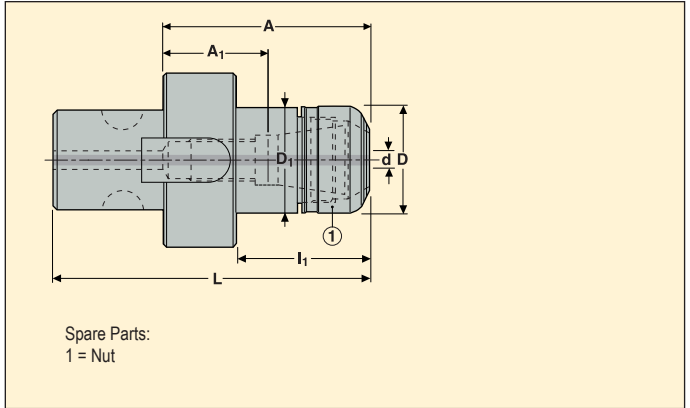



Graflex shank size	Capacity d mm	Part No.	Chuck & Collet Size	Dimensions in mm						Balancing	
				A	D	D ₁	L	I ₁	A ₁ min-max*		
G5	2-16	BM05056722560	HP 25	60	40	40	90	40	17-22	1	0,62
	2-20	BM06056723270	HP 32	70	50	50	110	44	15-22	1	1,22
G6											

For ER HP collets type 5672, see page(s) 297-300

* A1 setting length onto stop screw when possible, or total available setting length for chucks without thread for stop end screw.

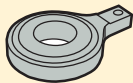
Accessories**

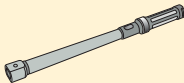
For size	Socket	Spanner	Stop screw	Torque key
				
HP 25	03EF567225	03B567225	19B58718	03DYD020200
HP 32	03EF567232	03B567232	19B58722	03DYD020200

Spare Parts

For size	Nut
	
HP 25	08B567225
HP 32	08B567232

Please check availability in current price and stock-list

** When using a stop end screw, its tapered contact onto the tool shank can increase the tool run-out defect

*** For tightening torques, see Guide pages

EPB 5834 - Hydraulic chucks

Graflex®

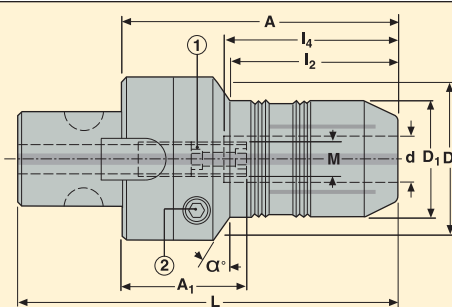

Accessories:
2 = Key for press screw

Spare Parts:
1 = Stop screw
2 = Screw

Graflex shank size	d mm	Part No.	Dimensions in mm							M mm	α°	Balancing	KG
			A	D	D ₁	L	I ₂	I ₄	A ₁ min-max				
G5	20	M58342820	90	50	42	120	47	52	42-52	M10	30	2	1,12
	25	M58343625	100	63	58	140	50	58	42-52	M10	30	2	2,24
G6	32	M58343632	100	64	-	140	-	63	52-62	M10	30	2	2,27

For reduction sleeves, see page(s) 295 and control gauges, see page(s) 296

Accessories

Spare Parts

For d	Locking key
20	H04-4
25	H04-4
32	H04-4

For d	Press screw	Stop screw
20	950AF1010010	19LS1020A
25	950AF1010010	19LS0820A
32	950AF1010010	19LS1020A

Please check availability in current price and stock-list

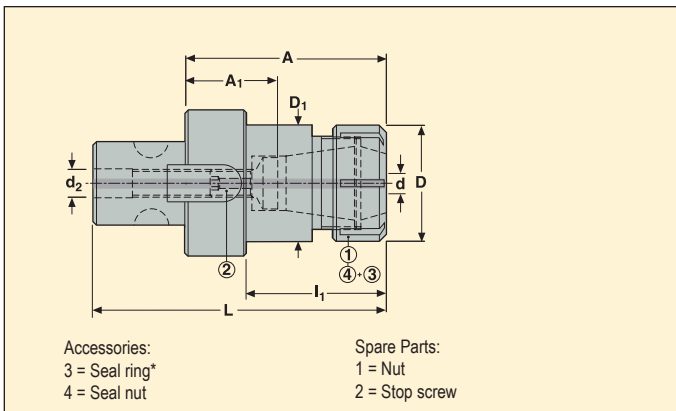

Graflex shank size	Capacity d mm	Part No.	Chuck & Collet Size	Dimensions in mm							Balancing	KG
				A	D	D ₁	d ₂	L	I ₁	A ₁ min-max		
G3	1-16	BM03056752570R	ER 25	70	35	32	6.5	90	-	30-32	2	0,35
G5	1-16	BM05056752560	ER 25	60	42	42	M12	90	40	17-22	2	0,66
	2-20	BM05056753275	ER 32	75	50	50	M12	105	-	25-32	2	0,92
G6	1-16	BM06056752560	ER 25	60	42	42	M12	100	34	20-22	2	1,09
	2-20	BM06056753275	ER 32	75	50	50	M12	115	49	25-32	2	1,32
	3-26	BM06056754085	ER 40	85	63	63	M12	125	-	26-35	2	1,73

For ER collets, see page(s) 302-303

ER extensions, see page(s) 301

Accessories*

For d	Seal nut	Spanner
G3/ ER 25	-	03B545025
G5/ ER 25	08B587525IC	03B587525
G5/ ER 32	08B587532IC	03B587532
G6/ ER 25	08B587525IC	03B587525
G6/ ER 32	08B587532IC	03B587532
G6/ ER 40	08B587540IC	03B587540

Spare Parts

For d	Nut	Stop screw
G3/ ER 25	08B587525M	19PM1016
G5/ ER 25	08B587525X	19PM1216
G5/ ER 32	08B587532X	19PM1220
G6/ ER 25	08B587525X	19PM1216
G6/ ER 32	08B587532X	19PM1220
G6/ ER 40	08B587540X	19PM1225

Please check availability in current price and stock-list
 * For ER type sealing rings, see page(s) 304

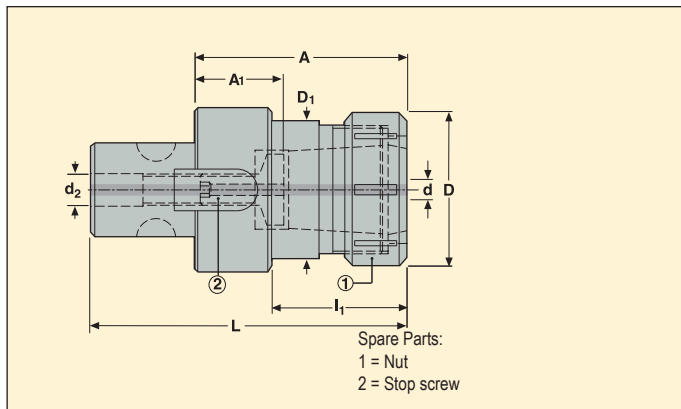

Graflex shank size	Capacity d mm	Part No.	Chuck & Collet Size	Dimensions in mm							Balancing	KG
				A	D	D ₁	d ₂	L	I ₁	A ₁ min-max		
G6	4-32	M58733632	OZ 32	90	72	63	M12	130	64	25-30	2	1,97

For OZ collets, see page(s) 305

Accessories

For size	Key
OZ 32	03B587332

Spare Parts

For size	Nut	Stop screw
OZ 32	08B587332	19PM1232

Please check availability in current price and stock-list

EPB 5085 – Universal drill chucks

Graflex®

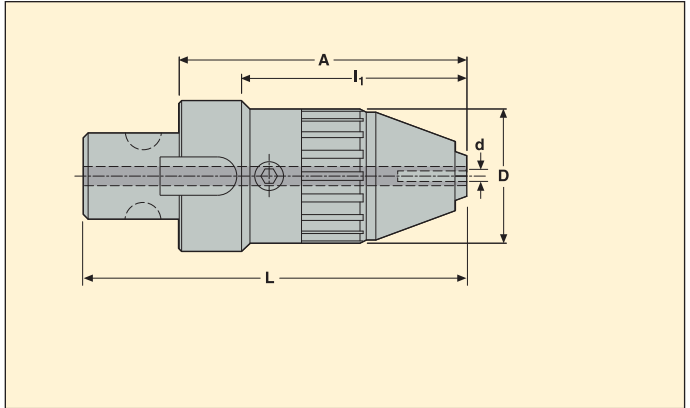

Graflex shank size	Capacity d mm	Part No.	Dimensions in mm				Balancing	
			A	D	L	I ₁		
G5	1-13	M50852813L	100	43	130	80	2	0,92
	2,5-16	M50853616L	120	56	160	94	2	2,01
G6								

Accessories

For Capacity d	Key
	
1-13	H06-4
2,5-16	H06-4

Please check availability in current price and stock-list

EPB 5283 – Quick change tapping chucks with axial compensation

Graflex®



- With extension and compression
- Without through coolant (for through coolant, see following page)

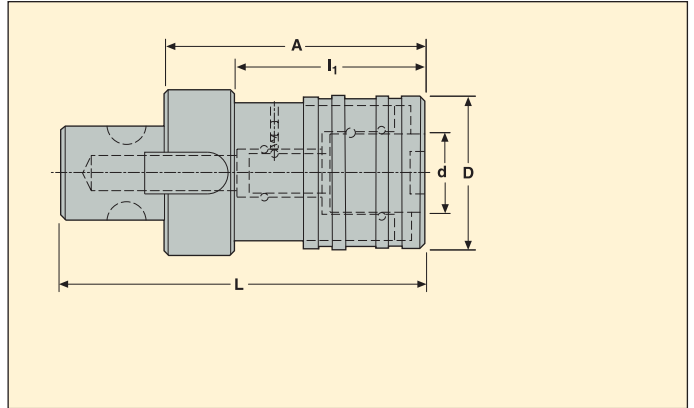

Graflex shank size	Tapping range	Part No.	For tap adapter		Dimensions in mm						
			Size	d mm	Compression	Extension	A	D	L	I ₁	
G4	M3-M12	M5283222	2	19	7,5	7,5	80	39	104	53	0,25

Please check availability in current price and stock-list
 For quick change tap adapters, see page(s) 311-312

EPB 5283 – Quick change tapping chucks with axial compensation, for through coolant

Graflex®

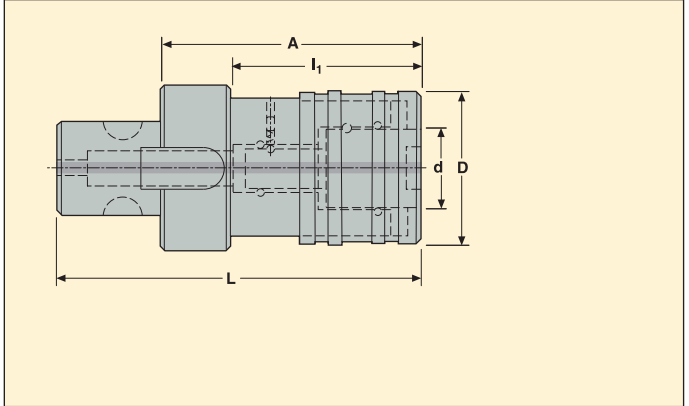

- With extension and compression
- Maximum coolant pressure 15 bar

Graflex shank size	Tapping range	Part No.	For tap adapter		Dimensions in mm						 KG
			Size	d mm	Compression	Extension	A	D	L	I ₁	
G5	M3-M12	M5283228L	2	19	7,5	7,5	70	39	100	50	0,73
	M8-M20	M5283336L	3	31	12,5	12,5	100	59	140	74	1,84
G6											

Please check availability in current price and stock-list
 For quick change tap adapters, see page(s) 311-312

EPB 5260 – Quick change tapping chucks for synchronized tapping

Graflex®



- No compensation.
- Maximum coolant pressure 50 bar

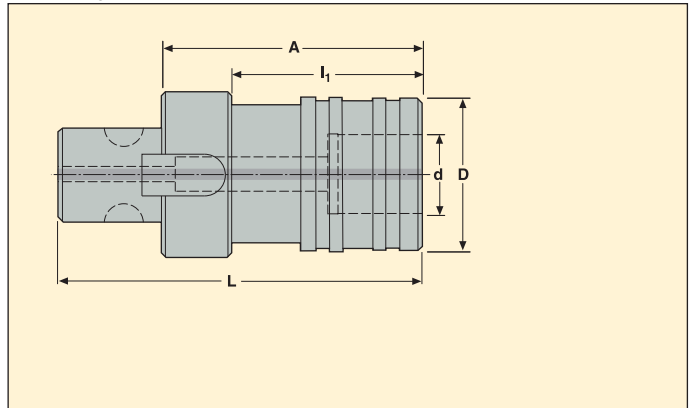

Graflex shank size	Tapping range	Part No.	For tap adapter		Dimensions in mm				
			Size	d mm	A	D	L	I ₁	
G3	M3-M12	M5260218	2	19	40	32	60	–	0,21
G5	M8-M20	M5260328	3	31	55	52	85	–	0,69
G6	M14-M33	M5260436	4	48	80	73	120	–	1,67

Please check availability in current price and stock-list

EPB 5865 – ER tapping chucks for synchronized tapping - DIN 6499

Graflex®



- No compensation

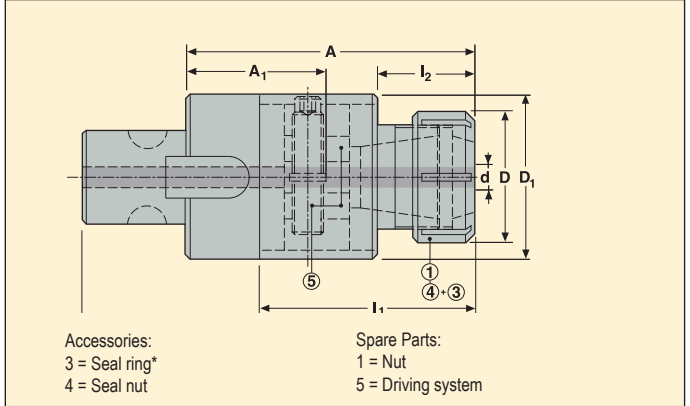

Graflex shank size	Tapping range	Part No.	For tap adapter		Dimensions in mm							 KG
			Size	d mm	A	D	D ₁	L	L ₁	L ₂	A ₁	
G5	M5-M20	M58652825	ER 25	1-16	85	42	42	115	65	33	39	0,86
	M5-M30	M58653632	ER 32	2-20	110	50	63	150	-	37	53,5	2,06
G6	M12-M33	M58653640	ER 40	3-26	115	63	63	155	-	43	52,5	2,33

For ER collets, see page(s) 302-303

Accessories*

For size	Key	Seal nut
ER 25	03B587525	08B587525IC
ER 32	03B587532	08B587532IC
ER 40	03B587540	08B587540IC

Spare Parts

For size	Driving system	Nut
ER 25	90T586525	08B587525X
ER 32	90T586532	08B587532X
ER 40	90T586532	08B587540X

Please check availability in current price and stock-list
 * For ER type sealing rings, see page(s) 304

EPB 6100 – Adjustable drill holders, for type 7 drill shanks - Metric

Graflex®



- For PerfoMax™ drills
- Adjustable from -0,3 mm to +0,8 mm on diameter

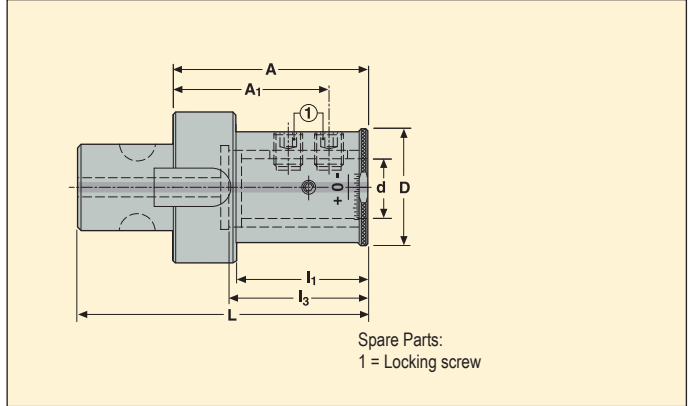

For drill shank type	d mm	Part No.	Dimensions in mm						Balancing	KG
			A	A ₁	D	L	I ₁	I ₃		
R7	25	BM061610025	70	55	49	110	54	54	–	1,12
	32	BM061610032	85	70	71	125	–	60,5	–	2,09
	40	BM061610040	85	70	81	125	–	60,5	–	2,38

Accessories

For d	Key	Reducing sleeve	Reducing sleeve 2
25	H06-4	–	–
32	H06-4	05B61003225	–
40	H06-4	05B61004025	05B61004032

Spare Parts

For d	Locking screw
25	950AF1210014
32	950AF1210020
40	950AF1210020

Please check availability in current price and stock-list

EPB 6101 – Adjustable drill holders, for type 7 drill shanks - Inch

Graflex®



- For Performax™ drills
- Adjustable from -0,3 mm to +0,8 mm on diameter

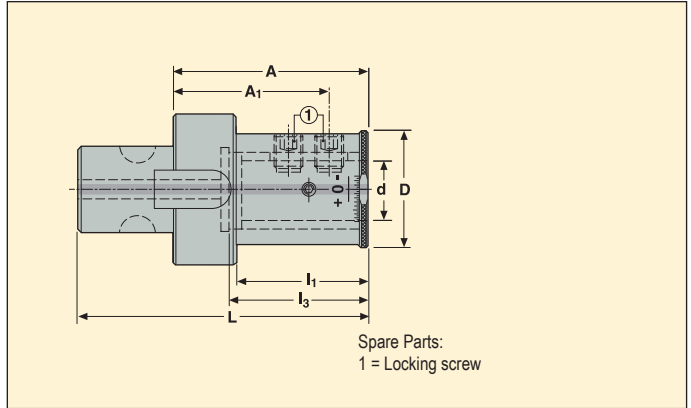

For drill shank type	d inch	Part No.	Dimensions in mm						Balancing	KG
			A	A ₁	D	L	I ₁	I ₃		
R7	1.00	BM061610125	70	55	49	110	54	54,5	-	1,11
	1.25	BM061610131	85	70	71	125	-	60,5	-	2,09
	1.50	BM061610138	85	70	81	125	-	60,5	-	2,45

Accessories

Spare Parts

For d	Key	Reducing sleeve	Reducing sleeve 2	For d	Locking screw
1.00	H06-4	-	-	1.00	950AF1210014
1.25	H06-4	05B61013125	-	1.25	950AF1210020
1.50	H06-4	05B61013825	05B61013831	1.50	950AF1210020

Please check availability in current price and stock-list

EPB 6181/A0 – Rotary coolant inducers, automatic tool change, for type 7 drill shanks - ISO 9766

Graflex®



- Filtration to 40 µm maximum required

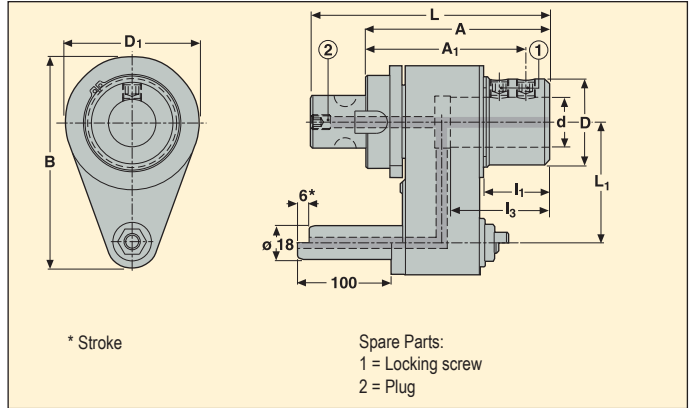

Graflex shank size	For drill shank type	d mm	Part No.	Dimensions in mm										Max pressure bar	Max rpm	KG
				A	A ₁	D	D ₁	L	L ₁	I ₁	I ₃	B				
G5	R7	25	BSM0516181255A0	105	90	39,5	60	135	80	42	54	127,5	20	6000	1,87	
G6	R7	32	BSM0616181326A0	110	95	55,0	90	150	80	42	58	142,5	20	4000	3,38	
	R7	40	BSM0616181406A0	115	100	63,0	90	155	80	47	65	142,5	20	4000	3,44	

Accessories

For d	Key	Reducing sleeve	Reducing sleeve 2	Socket
25	H06-4	–	–	E99000
32	H06-4	05B61003225	–	E99000
40	H06-4	05B61004025	05B61004032	E99000

Spare Parts

For d	Coolant tube	Locking screw	Plug
25	EU9023001	19X60841208	950A0810
32	EU9023001	19X608412	950A1012
40	EU9023001	19X608412	950A1012

Please check availability in current price and stock-list

EPB 6181/00 – Rotary coolant inducers, manual tool change, for type 7 drill shanks - Metric - ISO 9766

Graflex®



- Filtration to 40 μ m maximum required

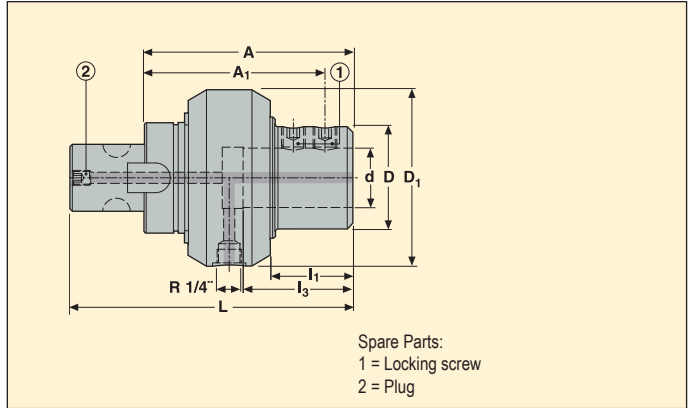

Graflex shank size	For drill shank type	d mm	Part No.	Dimensions in mm							Max pressure bar	Max rpm	Balancing	
				A	A ₁	D	D ₁	L	I ₁	I ₃				
G5	R7	25	BSM051618125100	105	90	39,5	75	135	42	54	20	6000	–	1,4
G6	R7	32	BSM061618132200	110	95	55,0	95	150	42	58	20	4000	–	2,74
	R7	40	BSM061618140200	115	100	63,0	95	155	47	65	20	4000	–	2,8

Accessories

For d	Key	Reducing sleeve	Reducing sleeve 2
25	H06-4	–	–
32	H06-4	05B61003225	–
40	H06-4	05B61004025	05B61004032

Spare Parts

For d	Locking screw	Plug
25	19X60841208	950A0810
32	19X608412	950A1012
40	19X608412	950A1012

Please check availability in current price and stock-list



- Filtration to 40 µm maximum required

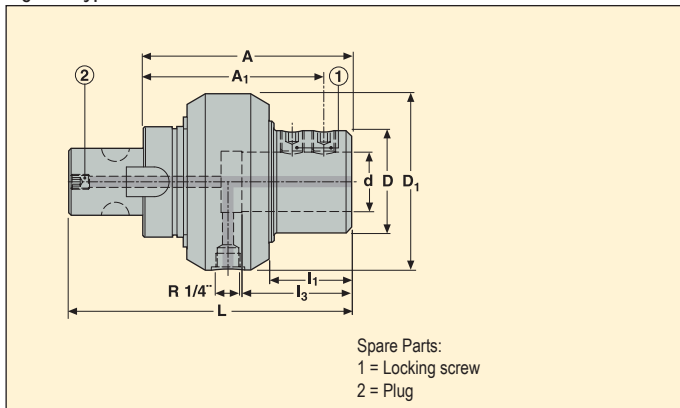

Graflex shank size	For drill shank type	d inch	Part No.	Dimensions in mm							Max pressure bar	Max rpm	Balancing	KG
				A	A ₁	D	D ₁	L	I ₁	I ₃				
G5	R7	1.00	BSM051618325100	105,4	90,4	39,5	75	135,4	42,4	54	20	6000	–	1,4
G6	R7	1.25	BSM061618331200	110,5	95,5	55,0	95	150,5	42,4	58	20	4000	–	2,74
	R7	1.50	BSM061618338200	115,5	100,5	63,0	95	155,5	47,5	65	20	4000	–	2,87

Accessories

For d	Key	Reducing sleeve	Reducing sleeve 2
1.00	H06-4	–	–
1.25	H06-4	05B61013125	–
1.50	H06-4	05B61013825	05B61013831

Spare Parts

For d	Locking screw	Plug
1.00	19X60841208	950A0810
1.25	19X608412	950A1012
1.50	19X608412	950A1012

Please check availability in current price and stock-list



- Filtration to 40 μm maximum required

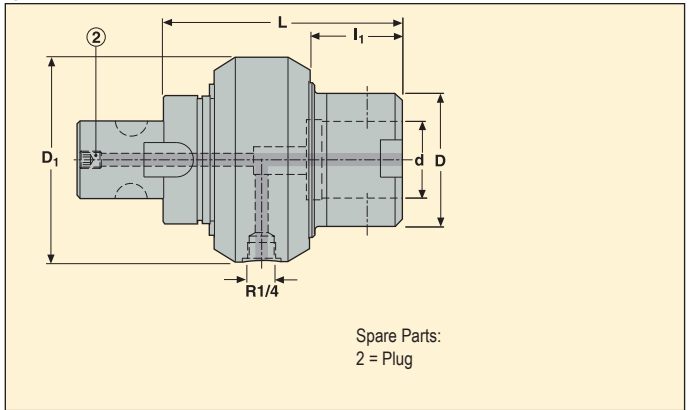

Graflex shank size	Graflex bore size		Part No.	Dimensions in mm				Max pressure bar	Max rpm	Balancing	
	Size	d mm		D	D ₁	L	I ₁				
G6	G5	28	BSM06140128200	50	95	130	22	20	4000	–	2,56
	G6	36	BSM06140136200	60	95	135	27	20	4000	–	2,66

Spare Parts

For d	Plug
28	950A1012
36	950A1012

Please check availability in current price and stock-list

Accessories and Spare parts for the Graflex® connection on Graflex arbors, intermediates and holders

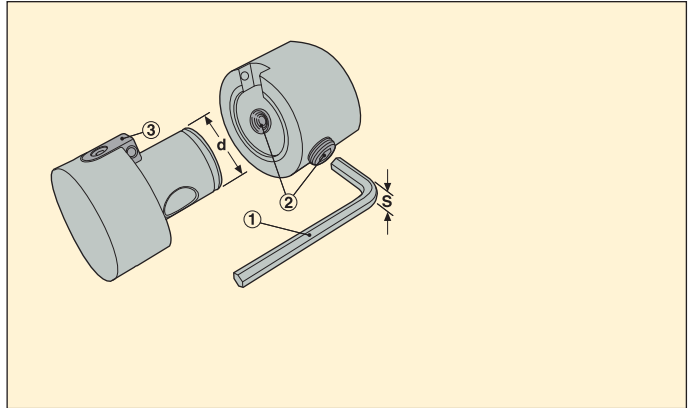

- For connection details and locking procedures, see the Guide pages.

Accessories and Spare parts	Description	Part No.	S	For Graflex connection d mm	For Graflex connection size	
					Female	Male
Accessories	Locking key (1)	03H02	2	08/11	0/1	–
	Locking key (1)	03H025	2,5	14	2	–
	Locking key (1)	03H03	3	18	3	–
	Locking key (1)	03H04	4	22	4	–
	Locking key (1)	03H05	5	28	5	–
	Locking key (1)	03H06	6	36	6	–
	Locking key (1)	03H10	10	46	7	–
Spare parts standard	Two ball nose screws kit (2)	90F0	2	08	0	–
	Two ball nose screws kit (2)	90F1	2	11	1	–
	Two ball nose screws kit (2)	90F2	2,5	14	2	–
	Two ball nose screws kit (2)	90F3	3	18	3	–
	Two ball nose screws kit (2)	90F4	4	22	4	–
	Two ball nose screws kit (2)	90F5	5	28	5	–
	Two ball nose screws kit (2)	90F6	6	36	6	–
	Two ball nose screws kit (2)	90F7	10	46	7	–
	Tenon kit (3)	90M0	–	08	–	0
	Tenon kit (3)	90M1	–	11	–	1
	Tenon kit (3)	90M2	–	14	–	2
	Tenon kit (3)	90M3	–	18	–	3
	Tenon kit (3)	90M4	–	22	–	4
	Tenon kit (3)	90M5	–	28	–	5
	Tenon kit (3)	90M6	–	36	–	6
	Tenon kit (3)	90M7	–	46	–	7
	Spare parts dedicated*	Two short ball nose screws kit (2)	90F01	2	08	0
Two short ball nose screws kit (2)		90F51	5	28	5	–
Two short ball nose screws kit (2)		90F71	10	46	7	–
Short tenon kit (3)		90M51	–	28	–	5
Short tenon kit (3)		90M61	–	36	–	6
Thin tenon kit (3)		90M7R	–	46	–	7

Please check availability in current price and stock-list

For the Accessories and Spare parts of the Graflex® connection on boring heads and on Lintline items, see Boring heads chapter in Holemaking catalogue.

* List of the Graflex® items requiring dedicated Graflex® connection Spare parts, see page(s) 212

List of the Graflex® items requiring dedicated Graflex® connection Spare parts

Dedicated Spare part		Suitable for				
90F01	Two short ball nose screws kit	M4011408C	-	-	-	-
90F71	Two short ball nose screws kit	-	-	-	EM3471 401 4650	-
90M51	Short tenon kit	-	BSM0516181255A0	-	-	BSM051618125100
		BSM051618325100	-	-	-	-
90M61	Short tenon kit	BM061610025	BM061610032	BM061610040	BM061610125	BM061610131
		BM061610138	-	-	-	-
		-	BSM0616181406A0	-	-	-
		-	BSM061618132200	BSM061618140200	BSM061618331200	BSM061618338200
		BSM06140128200	-	BSM06140136200	-	-
		-	-	M5260436	-	-
90M5R	Thin tenon kit	M55252822R	M55242827R	-	-	-
90M6R	Thin tenon kit	M55253627R	M55253627120R	-	-	-
90M7R	Thin tenon kit	-	-	M55254627R	M55254632R	-

For the Accessories and Spare parts of the Graflex® connection on boring heads and on Liteline items, see Boring heads chapter in Holemaking catalogue
 Graflex® items not listed above require standard Graflex® connection Spare parts, see page(s) 211

The Seco-Capto™ Tooling range shows:

- Seco-Capto™ Basic arbors: Basic arbors have a non Seco-Capto™ back-end shank (HSK, DIN, BT, ...) and a Seco-Capto™ receiver front-end to hold Seco-Capto™ tools, tool holders and intermediates onto rotating or static non PSC* type spindles.
- Seco-Capto™ Flange Mounts: Flange Mounts have a back end flange to be fitted onto SA spindle faces and a Seco-Capto™ receiver front end. For manual clamping of Seco-Capto™ tools, tool holders and intermediates onto rotating or static SA type spindles. Note: Seco-Capto™ Clamping Units to equip turning turrets are part of the Turning catalogue chapter.
- Seco-Capto™ Intermediates: Extensions and Reducers, with Seco-Capto™ shank back end and Seco-Capto™ receiver front end. To extend the length of Seco-Capto™ assemblies or to adapt Seco-Capto™ smaller size items onto larger ones.
- Seco-Capto™ Tool Holders: to hold rotary or static tools without PSC* coupling shank (Shell mill, Weldon, Shrinkfit, ...) onto PSC* type spindles or onto Seco-Capto™ Basic Holders, Flanges, Clamping Units and Intermediates. Note: Seco-Capto™ Adapters are the link to the Combimaster (milling) and Graflex (holders and boring heads) systems.

* PSC stands for Polygonal Shank Coupling, as defined by the Norm ISO26623.

Seco-Capto™ couplings (receivers or shanks) are in accordance with the Norm ISO26623.

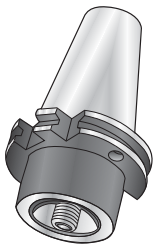

Basic arbors (and Flanges)

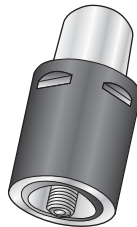

Intermediates

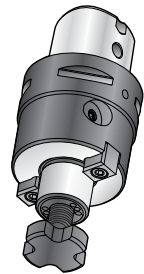

Tool holders (and Adapters)





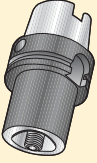
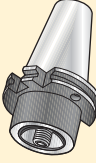
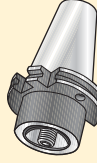
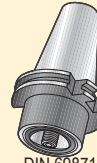
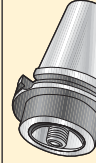
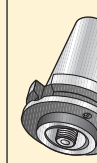
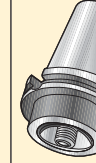
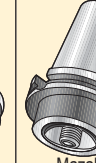
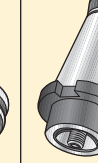



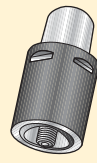
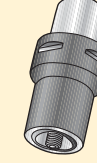

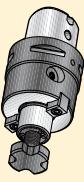
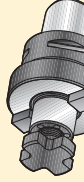
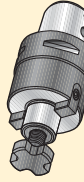

Basic arbors

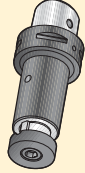
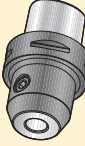
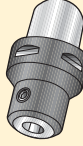
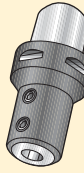
								
HSK A/C/T HSK 63, 100	DIN 69871 Form AD 30, 40, 50, 60	DIN 69871 Form B 40, 50	DIN 69871 Form AD/ ADB 40, 50	BT JIS Form AD 30, 40, 50	BT JIS Form B 40, 50	BT Form AD 40, 50	Mazak BT JIS Form AD 40, 50	DIN 2080 40, 50
C.-390.410/411	C.-390.140	C.-390.272	C.-390.540	C.-390.55/58	C.-390.369	C.-390.555/558	C.-390.605	C.-390.00
Page(s) 218-221	Page(s) 222-223	Page(s) 224-225	Page(s) 226-227	Page(s) 228-229	Page(s) 230-231	Page(s) 232-233	Page(s) 234-235	Page(s) 236-237





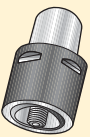
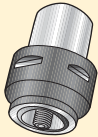

Intermediates

	
Extensions	Reducers
C.-391.01	C.-391.02
Page(s) 238-239	Page(s) 240-241

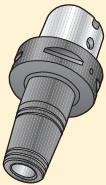
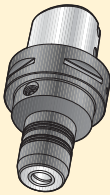
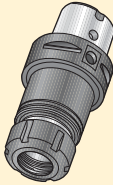
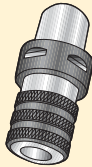
Tool holders

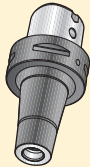
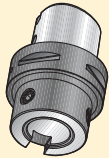
							
Shell mill holders, Accu-Fit™	Shell mill holders, with through coolant channels	Shell mill holders, with reduced facediameter	Steadyline™, vibration damping shell mill holders	Disc mill holders	Side lock holders Weldon/Seco Weldon	Side lock holders, Whistle Notch	Drill holders, ISO 9766
C.-391.5545	C.-391.5525/5524	C.-391.0552	C.-391.5555/ 5556	C.-391.5657	C.-391.0584 C.-391.20	C.-391.21	C.-391.27
Page(s) 246	Page(s) 248	Page(s) 249	Page(s) 247	Page(s) 250	Page(s) 251-254	Page(s) 255-256	Page(s) 257-258
							

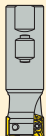
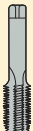
Intermediates, short version for segments clamping only	
	
Extensions	Reducers
C.-391.01	C.-391.02
Page(s) 242-243	Page(s) 244-245

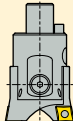
Tool holders						
						
Shrinkfit holders, DIN type	Hydraulic chucks	ER collet chucks, DIN 6499	Tapping chucks	Steadyline™ Combimaster holders	Combimaster adapters	Graflex® adapters
C.-391.5603 C.-391.5600 C.-391.5600P	C.-391.5835 C.-391.5834	C.-391.5672 C.-391.5675	C.-391.5867 C.-391.60/61	C.-391.K820/K821	C.-391.5820	C.-391.0401
Page(s) 259-262	Page(s) 263-265	Page(s) 266-268	Page(s) 269-273	Page(s) 274	Page(s) 275	Page(s) 276
						

Tightening torques for Seco-Capto™ receivers connections with centre bolt clamping (Basic arbors, Intermediates)

Seco-Capto size	Centre bolt tightening torque (Nm)
C3	40-50
C4	50-60
C5	90-100
C6	160-180
C8	160-180

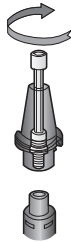

Tightening torques for Seco-Capto™ receivers connections with segment clamping, actuated by cam shaft side locking (Flange Mounts)

Seco-Capto size	Cam tightening torque (Nm)
C3	35
C4	50
C5	70
C6	90
C8	130

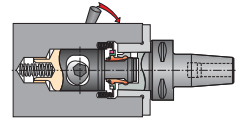

Seco-Capto™ shank sizes

Seco-Capto size	Dimensions in mm	
	D _{5m}	l ₅
C3	32	19
C4	40	24
C5	50	30
C6	63	38
C8	80	48

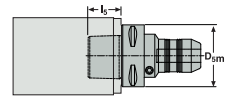

The Seco-Capto™ joint features a self-locking taper. Where the centre bolt system is used, unscrew the centre bolt until the bolt head makes contact with the tool holder, causing the bolt to force the taper joint apart. When using the cam shaft side clamping system, over untightening of the cam will force the taper joint apart.

Balancing

Where items are pre-balanced or fine-balanced, the balance quality is shown in the product pages:

1 = Fine balancing quality:

Unbalance $e = 3 \text{ g. mm/kg}$ maximum for items with mass $M \geq 1 \text{ kg}$ or $U = 3 \text{ g. mm}$ maximum for items $< 1 \text{ kg}$.

2 = Pre-balancing quality:

Unbalance $e = 30 \text{ g. mm/kg}$ maximum for items with mass $M \geq 1 \text{ kg}$ or $U = 30 \text{ g. mm}$ maximum for items $< 1 \text{ kg}$.

Most pre-balanced items can be fine-balanced on request, please enquire.

Housing for data carrier

More and more holders are with data carrier blind hole. If not already available, blind holes for data carriers can be machined and data carriers fitted on request, please enquire.

Code key, Basic arbors (and Flange Mounts)

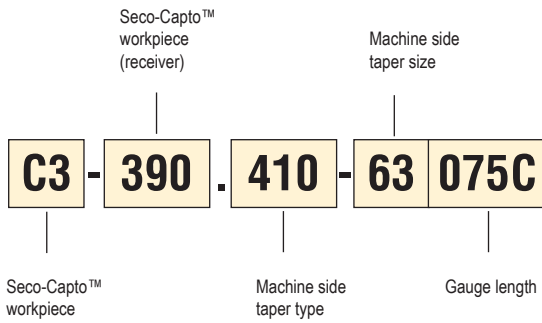

Code key, Intermediates

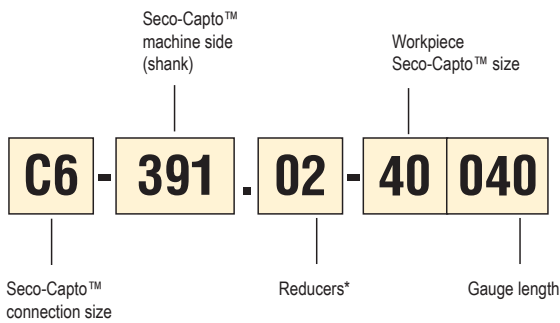

*01= Extensions
*02= Reducers

Code key, Tool Holders (and Adapters)

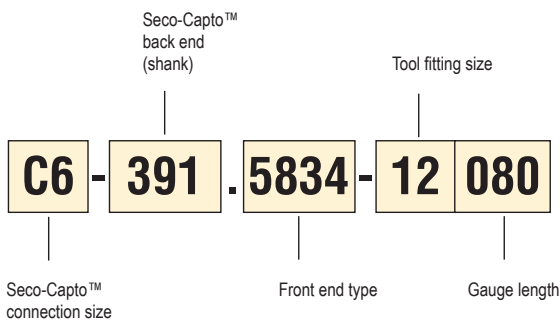

If a Part No. ends with a letter, it is an updated version of the holder, e.g. C4-391.20-12055A (update version A,B...)

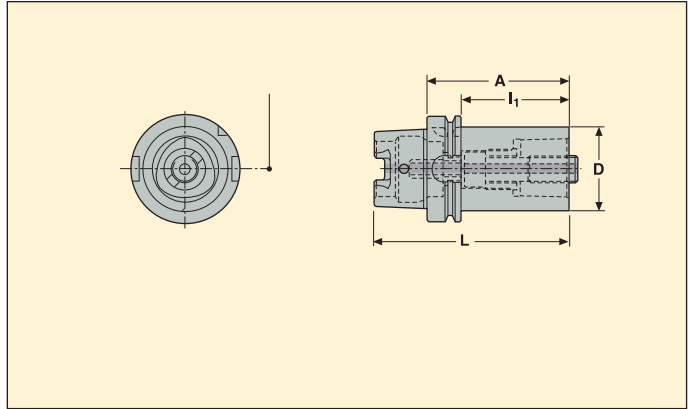

Seco-Capto™ size	Taper	Part No.	Dimensions in mm				Balancing	
			A	D	L	I ₁		
C3	HSK-A63	C3-390.410-63075C	75	32	107	49	2	0,9
	HSK-A100	C3-390.410-100080A	80	32	130	51	2	2,3
C4	HSK-A63	C4-390.410-63080C	80	40	112	54	2	1,1
	HSK-A100	C4-390.410-100090A	90	40	140	61	2	2,5
C5	HSK-A63	C5-390.410-63090C	90	50	122	64	2	1,4
	HSK-A100	C5-390.410-100100A	100	50	150	71	2	2,9
C6	HSK-A100	C6-390.410-100110A	110	63	160	81	2	3,6
C8	HSK-A100	C8-390.410-100120A	120	80	170	91	2	4,7

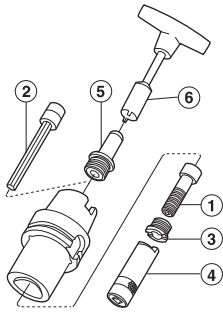

Please check availability in current price and stock-list
 Failure to fit a coolant tube or coolant plug may result in damage to the machine spindle



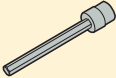

Accessories:
 2 = Extension key
 4 = Retaining nut spanner
 6 = Key for coolant tube

Spare Parts:
 1 = Centre screw
 3 = Retaining nut
 5 = Coolant tube*

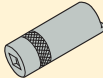
Accessories

For	Extension Key	Key	Spanner
			
C3-390.410-63075C	5680015-05	5680094-04	5680065-13
C3-390.410-100080A	5680015-05	5680094-06	5680065-13
C4-390.410-63080C	5680015-05	5680094-04	5680065-10
C4-390.410-100090A	5680015-05	5680094-06	5680065-10
C5-390.410-63090C	5680015-01	5680094-04	5680065-11
C5-390.410-100100A	5680015-01	5680094-06	5680065-11
C6-390.410-100110A	5680015-02	5680094-06	5680065-12
C8-390.410-100120A	5680015-02	5680094-06	5680065-12

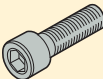
Spare Parts*

For	Centre screw	Coolant tube	Retaining nut
			
C3-390.410-63075C	5512063-10	5692020-04	5512091-04
C3-390.410-100080A	5512063-10	5692020-06	5512091-04
C4-390.410-63080C	5512063-07	5692020-04	5512091-03
C4-390.410-100090A	5512063-07	5692020-06	5512091-03
C5-390.410-63090C	5512063-08	5692020-04	5512091-01
C5-390.410-100100A	5512063-08	5692020-06	5512091-01
C6-390.410-100110A	5512063-09	5692020-06	5512091-02
C8-390.410-100120A	5512063-09	5692020-06	5512091-02

* A special coolant tube is delivered together with each Seco-Capto™ HSK basic holder

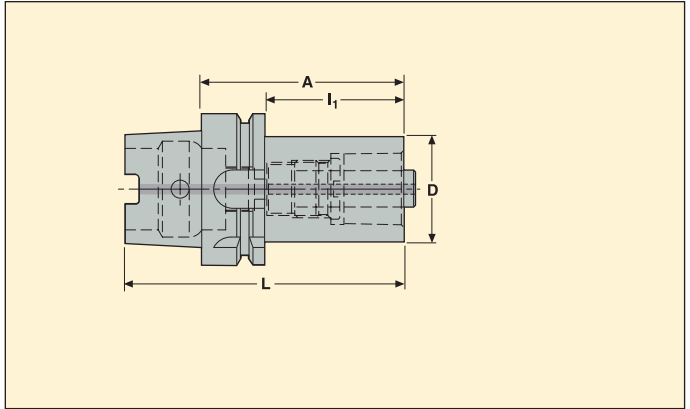

Seco-Capto™ size	Taper	Part No.	Dimensions in mm				Balancing	
			A	D	L	l ₁		
C4	HSK-T63	C4-390.411-63080	80	40	112	54	2	1,0
	HSK-T100	C4-390.411-100090	90	40	140	61	2	2,4
C5	HSK-T63	C5-390.411-63090	90	50	122	64	2	1,3
	HSK-T100	C5-390.411-100100	100	50	150	71	2	2,7
C6	HSK-T100	C6-390.411-100110	110	63	160	81	2	3,3
C8	HSK-T100	C8-390.411-100120	120	80	170	91	2	4,5

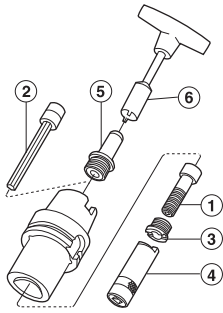

Please check availability in current price and stock-list
Failure to fit a coolant tube or coolant plug may result in damage to the machine spindle



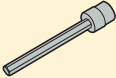

Accessories:
 2 = Extension key
 4 = Retaining nut spanner
 6 = Key for coolant tube

Spare Parts:
 1 = Centre screw
 3 = Retaining nut
 5 = Coolant tube*

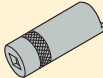
Accessories

For	Extension key	Key	Spanner
			
C4-390.411-63080	5680015-05	5680094-04	5680065-10
C4-390.411-100090	5680015-05	5680094-06	5680065-10
C5-390.411-63090	5680015-01	5680094-04	5680065-11
C5-390.411-100100	5680015-01	5680094-06	5680065-11
C6-390.411-100110	5680015-02	5680094-06	5680065-12
C8-390.411-100120	5680015-02	5680094-06	5680065-12

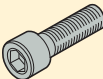
Spare Parts*

For	Centre screw	Coolant tube	Retaining nut
			
C4-390.411-63080	5512063-07	5692020-04	5512091-03
C4-390.411-100090	5512063-07	5692020-06	5512091-03
C5-390.411-63090	5512063-08	5692020-04	5512091-01
C5-390.411-100100	5512063-08	5692020-06	5512091-01
C6-390.411-100110	5512063-09	5692020-06	5512091-02
C8-390.411-100120	5512063-09	5692020-06	5512091-02

* A special coolant tube is delivered together with each Seco-Capto™ HSK basic holder

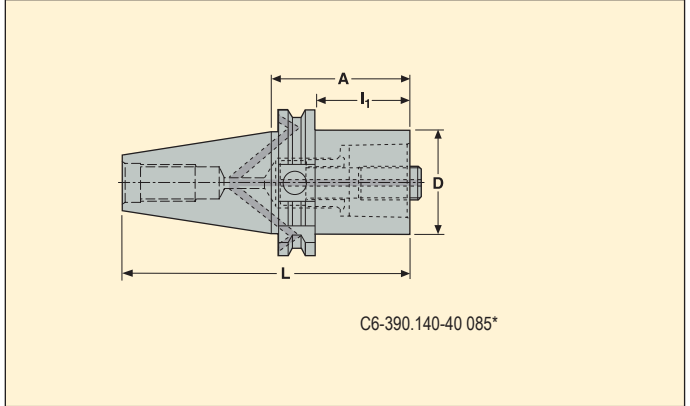

Seco-Capto™ size	Taper	Part No.	*	Dimensions in mm				Balancing	
				A	D	L	I ₁		
C3	DIN30 AD	C3-390.140-30030		30	32	77,8	–	–	0,5
	DIN30 AD	C3-390.140-30060		60	32	107,8	–	–	0,6
	DIN40 AD	C3-390.140-40030		30	32	98,4	–	2	0,8
	DIN40 AD	C3-390.140-40060		60	32	128,4	–	2	1,0
	DIN50 AD	C3-390.140-50030		30	32	131,75	–	–	2,6
	DIN50 AD	C3-390.140-50060		60	32	161,75	–	–	2,8
C4	DIN40 AD	C4-390.140-40030		30	40	98,4	–	2	0,8
	DIN40 AD	C4-390.140-40060		60	40	128,4	–	2	1,1
	DIN50 AD	C4-390.140-50030		30	40	131,75	–	–	2,6
	DIN50 AD	C4-390.140-50060		60	40	161,75	–	–	2,9
C5	DIN40 AD	C5-390.140-40030		30	50	98,4	–	2	0,8
	DIN40 AD	C5-390.140-40070		70	50	138,4	–	2	1,4
	DIN50 AD	C5-390.140-50030		30	50	131,75	–	–	2,6
	DIN50 AD	C5-390.140-50070		70	50	171,75	–	–	3,1
C6	DIN40 AD	C6-390.140-40085	*	85	63	153,4	65,9	–	1,8
	DIN50 AD	C6-390.140-50030		30	63	131,75	–	–	2,5
	DIN50 AD	C6-390.140-50080		80	63	181,75	–	–	3,6
C8	DIN50 AD	C8-390.140-50070		70	80	171,75	–	–	3,7
	DIN50 AD	C8-390.140-50120		120	80	221,75	–	–	5,5

Please check availability in current price and stock-list
 * For light machining only

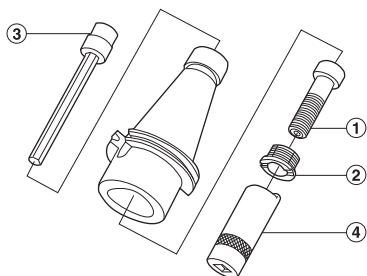

Accessories:
 3 = Extension key
 4 = Retaining nut spanner

Spare Parts:
 1 = Centre screw
 2 = Retaining nut

Accessories

For Capto size	Extension Key	Spanner
C3	5680015-05	5680065-13
C4	5680015-05	5680065-10
C5	5680015-01	5680065-11
C6-40085	5680015-01	5680065-12
C6	5680015-02	5680065-12
C8	5680015-02	5680065-12

Spare Parts

For Capto size	Centre screw	Retaining nut
C3	5512063-10	5512091-04
C4	5512063-07	5512091-03
C5	5512063-08	5512091-01
C6-40085	5512063-13	5512091-02
C6	5512063-09	5512091-02
C8	5512063-09	5512091-02



- Coolant through flange

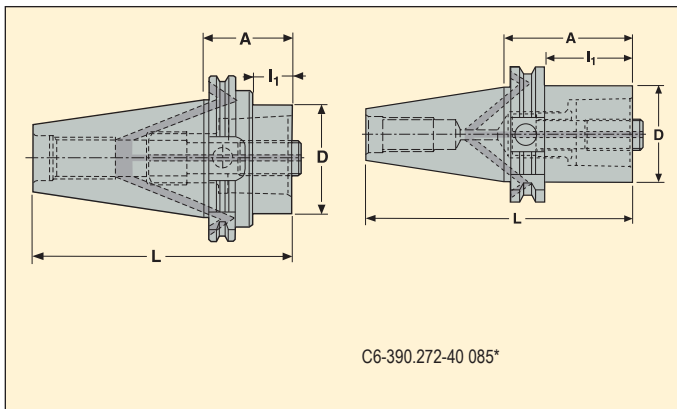

Seco-Capto™ size	Taper	Part No.	*	Dimensions in mm				Balancing	
				A	D	L	I ₁		
C3	DIN40 B	C3-390.272-40030		30	32	98,4	10,9	2	0,8
	DIN40 B	C3-390.272-40060		60	32	128,4	40,9	2	1,2
	DIN50 B	C3-390.272-50030		30	32	131,75	10,9	–	2,6
	DIN50 B	C3-390.272-50060		60	32	161,75	40,9	–	2,8
C4	DIN40 B	C4-390.272-40030		30	40	98,4	10,9	2	0,8
	DIN40 B	C4-390.272-40060		60	40	128,4	40,9	2	1,1
	DIN50 B	C4-390.272-50030		30	40	131,75	10,9	–	2,6
	DIN50 B	C4-390.272-50060		60	40	161,75	40,9	–	2,8
C5									
	DIN40 B	C5-390.272-40040		40	50	108,4	20,9	2	0,9
	DIN40 B	C5-390.272-40080		80	50	148,4	60,9	2	1,5
	DIN50 B	C5-390.272-50030		30	50	131,75	–	–	2,8
C6									
	DIN40 B	C6-390.272-40085	*	85	63	153,4	66,0	2	1,8
	DIN50 B	C6-390.272-50030		30	63	131,75	–	–	2,6
	DIN50 B	C6-390.272-50080		80	63	181,75	51,0	–	3,7
C8									
	DIN50 B	C8-390.272-50070		70	80	171,75	50,9	–	3,7
	DIN50 B	C8-390.272-50120		120	80	221,75	100,9	–	5,5

Please check availability in current price and stock-list
 * For light machining only

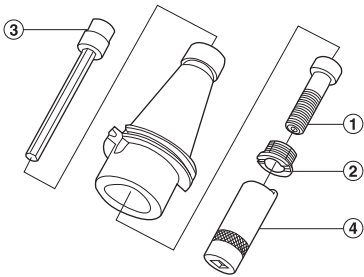



Accessories:
 3 = Extension key
 4 = Retaining nut spanner

Spare Parts:
 1 = Centre screw
 2 = Retaining nut

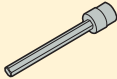
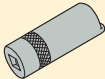
Accessories

For	Extension Key	Spanner
		
C3	5680015-05	5680065-13
C4	5680015-05	5680065-10
C5	5680015-01	5680065-11
C6-40085	5680015-01	5680065-12
C6	5680015-02	5680065-12
C8	5680015-02	5680065-12

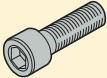
Spare Parts

For	Centre screw	Retaining nut
		
C3	5512063-10	5512091-04
C4	5512063-07	5512091-03
C5	5512063-08	5512091-01
C6-40085	5512063-13	5512091-02
C6	5512063-09	5512091-02
C8	5512063-09	5512091-02



• Licence BIG DAISHOWA

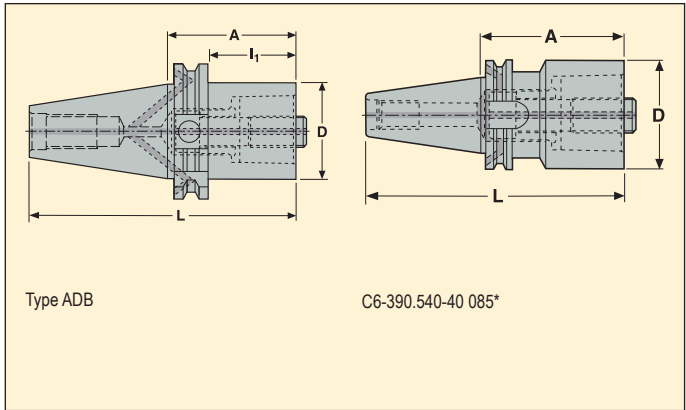

Seco-Capto™ size	Taper	Part No.	*	Dimensions in mm				Balancing	
				A	D	L	I ₁		
C3	DIN TF40 AD (Taper Face)	C3-390.540-40030		30	32	98,4	10,9	2	0,9
	DIN TF50 ADB (Taper Face)	C3-390.540-50030A		30	32	131,75	10,9	-	2,6
	DIN TF50 AD (Taper Face)	C3-390.540-50060		60	32	161,6	40,9	-	2,9
C4	DIN TF40 AD (Taper Face)	C4-390.540-40040		40	40	108,4	20,9	2	0,9
	DIN TF50 ADB (Taper Face)	C4-390.540-50030A		30	40	131,75	10,9	-	2,7
	DIN TF50 ADB (Taper Face)	C4-390.540-50060		60	40	161,75	40,9	-	2,9
C5	DIN TF40 AD (Taper Face)	C5-390.540-40050		50	50	118,4	30,9	2	1,1
	DIN TF50 ADB (Taper Face)	C5-390.540-50030A		30	50	131,75	10,9	-	2,6
	DIN TF50 ADB (Taper Face)	C5-390.540-50070		70	50	171,6	50,9	-	3,2
C6	DIN TF40 AD (Taper Face)	C6-390.540-40085	*	85	63	153,4	65,9	2	1,8
	DIN TF50 ADB (Taper Face)	C6-390.540-50050A		50	63	151,75	-	-	2,9
C8	DIN TF50 ADB (Taper Face)	C8-390.540-50070A		70	80	171,75	50,9	-	3,7

Please check availability in current price and stock-list
 * For light machining only

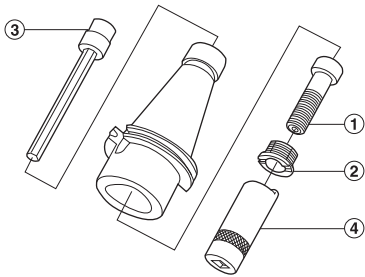

Accessories:
 3 = Extension key
 4 = Retaining nut spanner

Spare Parts:
 1 = Centre screw
 2 = Retaining nut

Accessories

For	Extension key	Extension Key	Spanner
C3	–	5680015-05	5680065-13
C3-50060	5680015-05	–	5680065-13
C4	–	5680015-05	5680065-10
C4-50060	5680015-05	–	5680065-10
C5	–	5680015-01	5680065-11
C5-50070	5680015-01	–	5680065-11
C6-40085	–	5680015-01	5680065-12
C6-50050A	–	5680015-02	5680065-12
C8	–	5680015-02	5680065-12

Spare Parts

For	Centre screw	Retaining nut	Sealing plugs
C3	5512063-10	5512091-04	–
C3-50060	5512063-10	5512091-04	564301702
C4	5512063-07	5512091-03	–
C4-50060	5512063-07	5512091-03	564301702
C5	5512063-08	5512091-01	–
C5-50070	5512063-08	5512091-01	564301702
C6-40085	5512063-13	5512091-02	–
C6-50050A	5512063-09	5512091-02	–
C8	5512063-09	5512091-02	–

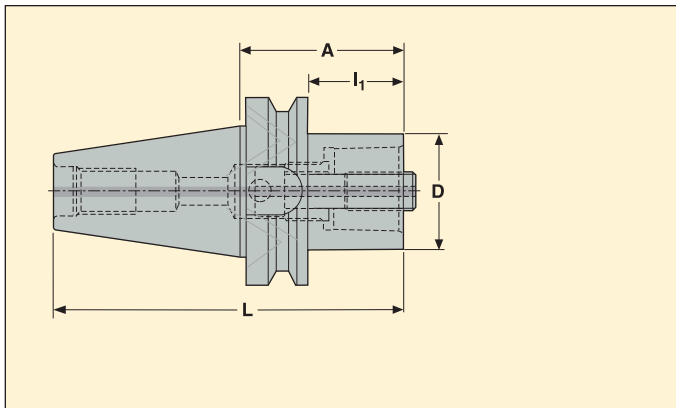

Seco-Capto™ size	Taper	Part No.	Dimensions in mm				Balancing	
			A	D	L	I ₁		
C3	BT30 AD	C3-390.55-30030	30	32	78,4	8,0	–	0,5
	BT30 AD	C3-390.55-30060	60	32	108,4	38,0	–	0,7
	BT40 AD	C3-390.55-40030	30	32	95,4	3,0	2	0,9
	BT40 AD	C3-390.55-40060	60	32	125,4	33,0	2	1,2
	BT50 ADB	C3-390.58-50040	40	32	141,8	2,0	–	2,5
	BT50 ADB	C3-390.58-50070	70	32	171,8	32,0	–	2,7
C4	BT40 AD	C4-390.55-40030	30	40	95,4	3,0	2	0,9
	BT40 AD	C4-390.55-40060	60	40	125,4	33,0	2	1,2
	BT50 AD	C4-390.58-50040	40	40	141,8	2,0	–	3,5
	BT50 AD	C4-390.58-50070	70	40	171,8	32,0	–	2,7
C5	BT40 AD	C5-390.55-40030	30	50	95,4	3,0	2	0,8
	BT40 AD	C5-390.55-40070	70	50	135,4	43,0	2	1,4
	BT50 AD	C5-390.58-50040	40	50	141,8	2,0	–	3,4
	BT50 AD	C5-390.58-50080	80	50	181,8	42,0	–	3,9
C6	BT40 AD	C6-390.55-40075	75	63	140,4	–	–	2,7
	BT50 AD	C6-390.58-50040	40	63	141,8	2,0	–	3,3
	BT50 AD	C6-390.58-50090	90	63	191,8	52,0	–	4,4
C8	BT50 AD	C8-390.58-50070	70	80	171,8	32,0	–	4,0
	BT50 AD	C8-390.58-50120	120	80	221,8	82,0	–	5,8

Please check availability in current price and stock-list

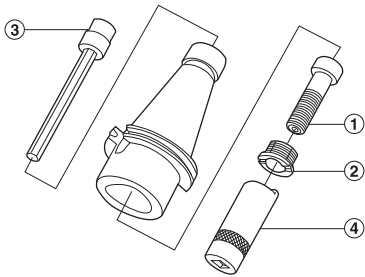



Accessories:
 3 = Extension key
 4 = Retaining nut spanner

Spare Parts:
 1 = Centre screw
 2 = Retaining nut

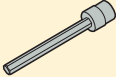
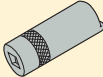
Accessories

For	Extension Key	Spanner
		
C3-390.55/58-	5680015-05	5680065-13
C4-390.55/58-	5680015-05	5680065-10
C5-390.55/58-	5680015-01	5680065-11
C6-390.55-40075	5680015-01	5680065-12
C6-390.58-	5680015-02	5680065-12
C8-390.58-	5680015-02	5680065-12

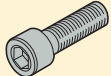
Spare Parts

For	Centre screw	Retaining nut
		
C3-390.55/58-	5512063-10	5512091-04
C4-390.55/58-	5512063-07	5512091-03
C5-390.55/58-	5512063-08	5512091-01
C6-390.55-40075	5512063-13	5512091-02
C6-390.58-	5512063-09	5512091-02
C8-390.58-	5512063-09	5512091-02

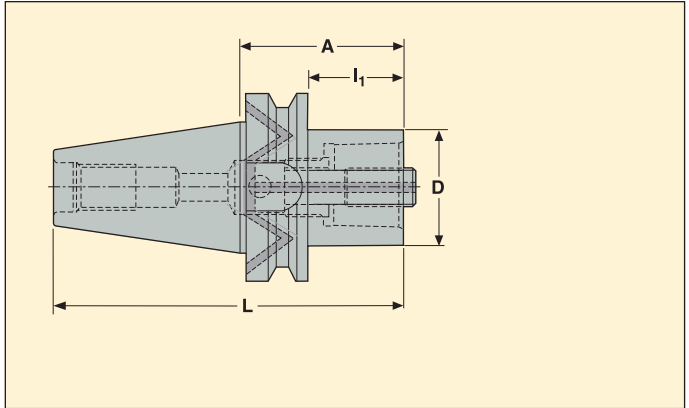

Seco-Capto™ size	Taper	Part No.	Dimensions in mm				Balancing	
			A	D	L	I ₁		
C3	BT40 B	C3-390.369-40030	30	32	95,4	3,0	2	0,9
	BT50 B	C3-390.369-50040	40	32	141,8	2,0	–	3,6
C4	BT40 B	C4-390.369-40030	30	40	95,4	3,0	2	0,9
	BT50 B	C4-390.369-50040	40	40	141,8	2,0	–	3,5
C5	BT40 B	C5-390.369-40050	50	50	115,4	23,0	2	1,1
	BT50 B	C5-390.369-50040	40	50	141,8	2,0	–	1,3
C6	BT50 B	C6-390.369-50050	50	63	151,8	12,0	–	3,4
C8	BT50 B	C8-390.369-50070	70	80	171,8	32,0	–	3,9

Please check availability in current price and stock-list

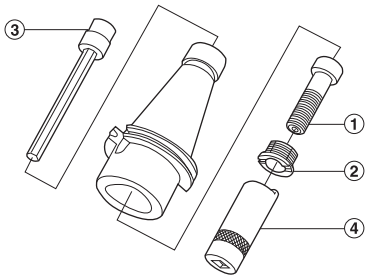

Accessories:
 3 = Extension key
 4 = Retaining nut spanner

Spare Parts:
 1 = Centre screw
 2 = Retaining nut

Accessories

For Capto size	Extension Key	Spanner
C3	5680015-05	5680065-13
C4	5680015-05	5680065-10
C5	5680015-01	5680065-11
C6	5680015-02	5680065-12
C8	5680015-02	5680065-12

Spare Parts

For Capto size	Centre screw	Retaining nut
C3	5512063-10	5512091-04
C4	5512063-07	5512091-03
C5	5512063-08	5512091-01
C6	5512063-09	5512091-02
C8	5512063-09	5512091-02

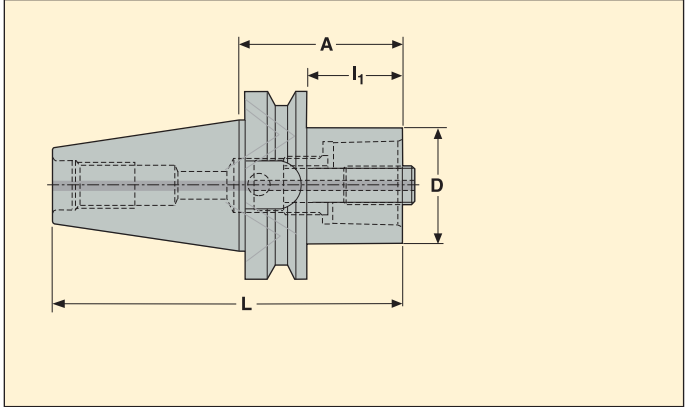

• Licence BIG DAISHOWA

Seco-Capto™ size	Taper	Part No.	Dimensions in mm				Balancing	
			A	D	L	I ₁		
C3	BT TF40 AD (Taper Face)	C3-390.555-40030	30	32	95,4	3,0	–	1,0
C4	BT TF40 AD (Taper Face)	C4-390.555-40040	40	40	105,4	13,0	2	1,1
	BT TF50 AD (Taper Face)	C4-390.558-50040	40	50	141,8	2,0	–	3,6
C5	BT TF40 AD (Taper Face)	C5-390.555-40050	50	50	115,4	23,0	2	1,1
	BT TF50 AD (Taper Face)	C5-390.558-50040	40	50	141,8	2,0	–	3,5
C6	BT TF40 AD (Taper Face)	C6-390.555-40075	75	63	140,4	12,0	–	1,7
	BT TF50 AD (Taper Face)	C6-390.558-50050	50	63	151,8	–	–	3,7
C8	BT TF50 AD (Taper Face)	C8-390.558-50070	70	80	171,8	32,0	–	4,0

Please check availability in current price and stock-list

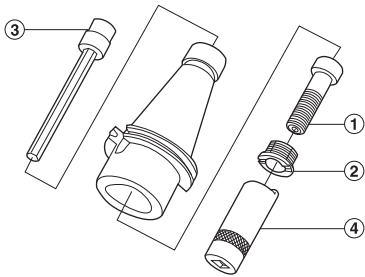



Accessories:
 3 = Extension key
 4 = Retaining nut spanner

Spare Parts:
 1 = Centre screw
 2 = Retaining nut

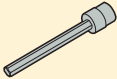
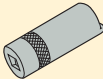
Accessories

For Capto size	Extension key	Spanner
		
C3	5680015-05	5680065-13
C4	5680015-05	5680065-10
C5	5680015-01	5680065-11
C6	5680015-02	5680065-12
C8	5680015-02	5680065-12

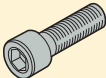
Spare Parts

For Capto size	Centre screw	Retaining nut
		
C3	5512063-10	5512091-04
C4	5512063-07	5512091-03
C5	5512063-08	5512091-01
C6	5512063-09	5512091-02
C8	5512063-09	5512091-02



- 90° rotated Seco-Capto™ polygon compared to a classic basic BT holder

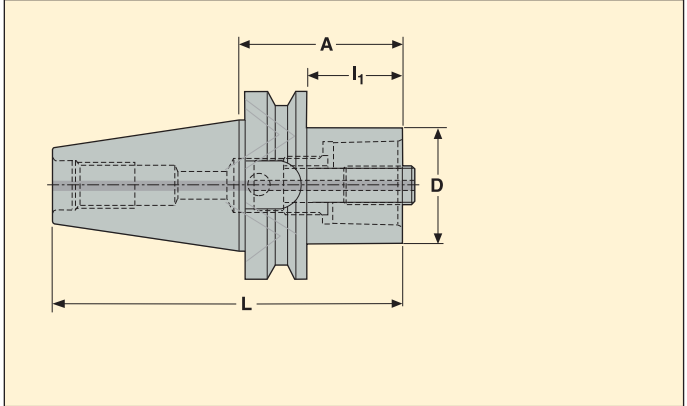

Seco-Capto™ size	Taper	Part No.	Dimensions in mm				Balancing	
			A	D	L	I ₁		
C5	BT40 AD	C5-390.605-40030	30	50	95,4	3,0	-	1,1
C6	BT50 AD	C6-390.605-50040	40	63	141,8	2,0	-	3,3
C8	BT50 AD	C8-390.605-50070	70	80	171,8	70,0	-	4,1

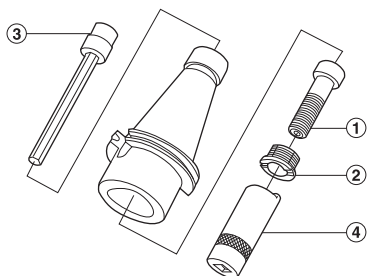



Accessories:
 3 = Extension key
 4 = Retaining nut spanner

Spare Parts:
 1 = Centre screw
 2 = Retaining nut

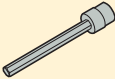
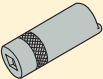
Accessories

For Capto size	Extension key	Spanner
		
C5	5680015-01	5680065-11
C6	5680015-02	5680065-12
C8	5680015-02	5680065-12

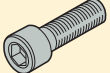
Spare Parts

For Capto size	Centre screw	Retaining nut
		
C5	5512063-08	5512091-01
C6	5512063-09	5512091-02
C8	5512063-09	5512091-02

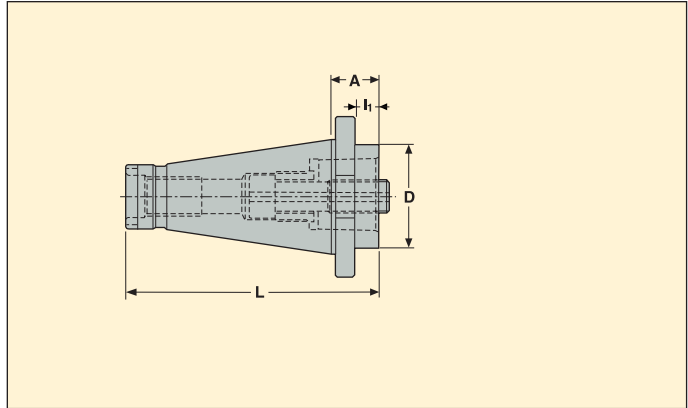

Seco-Capto™ size	Taper	Part No.	Dimensions in mm				Balancing	
			A	D	L	I ₁		
C3	DIN(2080)40	C3-390.00-40030	30	32	123,4	18,4	–	0,8
	DIN(2080)40	C3-390.00-40060	60	32	153,4	48,4	–	0,1
	DIN(2080)50	C3-390.00-50030	30	32	156,8	14,8	–	2,5
	DIN(2080)50	C3-390.00-50060	60	32	186,8	44,8	–	2,5
C4	DIN(2080)40	C4-390.00-40030	30	40	123,4	18,4	–	0,8
	DIN(2080)40	C4-390.00-40060	60	40	153,4	48,4	–	1,1
	DIN(2080)50	C4-390.00-50030	30	40	156,8	14,8	–	2,5
	DIN(2080)50	C4-390.00-50060	60	40	186,8	44,8	–	2,5
C5	DIN(2080)40	C5-390.00-40030	30	50	123,4	18,4	–	0,8
	DIN(2080)40	C5-390.00-40070	70	50	163,4	58,4	–	1,4
	DIN(2080)50	C5-390.00-50030	30	50	156,8	14,8	–	2,6
	DIN(2080)50	C5-390.00-50070	70	50	196,8	54,8	–	3,3
C6	DIN(2080)40	C6-390.00-40075	75	63	168,4	–	–	1,8
	DIN(2080)50	C6-390.00-50030	30	63	156,8	14,8	–	2,6
	DIN(2080)50	C6-390.00-50080	80	63	206,8	64,8	–	3,3
C8	DIN(2080)50	C8-390.00-50070	70	80	196,8	54,8	–	3,8
	DIN(2080)50	C8-390.00-50120	120	80	246,8	104,8	–	5,6

Please check availability in current price and stock-list

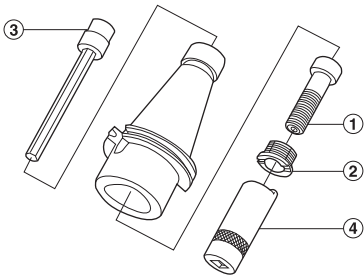



Accessories:
 3 = Extension key
 4 = Retaining nut spanner

Spare Parts:
 1 = Centre screw
 2 = Retaining nut

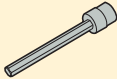
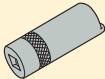
Accessories

For	Extension Key	Spanner
		
C3	5680015-05	5680065-13
C4	5680015-05	5680065-10
C5	5680015-01	5680065-11
C6	5680015-02	5680065-12
C6-40075	5680015-01	5680065-12
C8	5680015-02	5680065-12

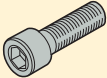
Spare Parts

For	Centre screw	Retaining nut
		
C3	5512063-10	5512091-04
C4	5512063-07	5512091-03
C5	5512063-08	5512091-01
C6	5512063-09	5512091-02
C6-40075	5512063-13	5512091-02
C8	5512063-09	5512091-02

EPB 01 - Seco-Capto™ extensions - ISO 26623-1

Seco-Capto™ / ISO 26623-1

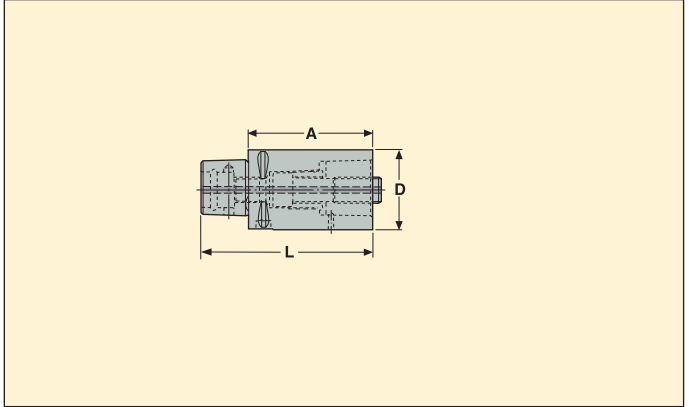

Seco-Capto™ shank	Seco-Capto™ receiver	Part No.	Dimensions in mm			 KG
			A	D	L	
C3	C3	C3-391.01-32060A	60	32	79	0,3
	C3	C3-391.01-32080A	80	32	99	0,5
C4	C4	C4-391.01-40060A	60	40	84	0,5
	C4	C4-391.01-40080A	80	40	104	0,7
C5	C5	C5-391.01-50080A	80	50	110	1,1
	C5	C5-391.01-50100A	100	50	130	1,4
C6	C6	C6-391.01-63100A	100	63	138	2,2
	C6	C6-391.01-63140A	140	63	178	3,1
C8	C8	C8-391.01-80100A	100	80	148	3,6
	C8	C8-391.01-80125A	125	80	173	4,5

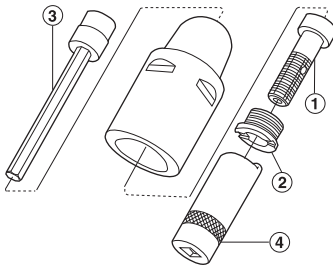

Please check availability in current price and stock-list



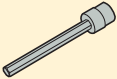

Accessories:
 3 = Extension key
 4 = Retaining nut spanner

Spare Parts:
 1 = Centre screw
 2 = Retaining nut

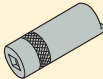
Accessories

For	Extension key	Pin	Spanner
			
C...-32	5680015-05	3113020-304	5680065-13
C...-40	5680015-05	3113020-355	5680065-10
C...-50	5680015-01	3113020-406	5680065-11
C...-63	5680015-02	3113020-457	5680065-12
C...-80	5680015-02	3113020-509	5680065-12

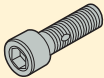
Spare Parts

For	Centre screw	Retaining ring
		
C...-32	5512067-01	5512091-04
C...-40	5512067-02	5512091-03
C...-50	5512067-03	5512091-01
C...-63	5512067-04	5512091-02
C...-80	5512067-04	5512091-02

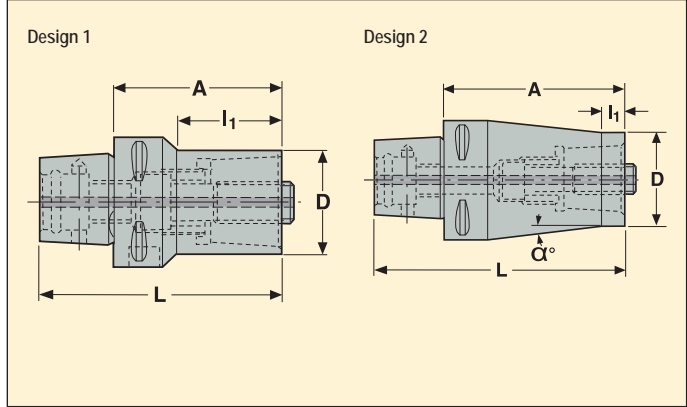

Seco-Capto™ shank	Seco-Capto™ receiver	Part No.	Dimensions in mm				α°	Design	
			A	D	L	L ₁			
C4	C3	C4-391.02-32055A	55	32	79	31	-	1	0,4
	C3	C4-391.02-32070A	70	32	94	12	6	2	0,6
C5	C3	C5-391.02-32060A	60	32	90	34,8	-	1	0,6
	C4	C5-391.02-40065A	65	40	95	40	-	1	0,8
C6	C3	C6-391.02-32070A	70	32	108	39	-	1	1,1
	C4	C6-391.02-40080A	80	40	118	51,4	-	1	1,2
	C5	C6-391.02-50080A	80	50	118	51,5	-	1	1,5
	C5	C6-391.02-50110A	110	50	148	12	4,5	2	2,2
C8	C3	C8-391.02-32060A	60	32	108	29,3	-	1	1,7
	C4	C8-391.02-40070A	70	40	118	36,5	-	1	1,9
	C5	C8-391.02-50080A	80	50	128	49,3	-	1	2,2
	C6	C8-391.02-63080A	80	63	128	53,1	-	1	2,4
	C6	C8-391.02-63120A	120	63	168	12	6	2	4,0

Please check availability in current price and stock-list

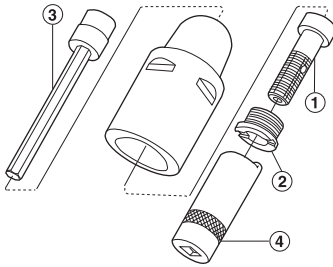



Accessories:
 3 = Extension key
 4 = Retaining nut spanner

Spare Parts:
 1 = Centre screw
 2 = Retaining nut

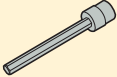
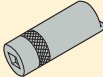
Accessories

For	Extension key	Spanner
		
C...-32	5680015-05	5680065-13
C...-40	5680015-05	5680065-10
C...-50	5680015-01	5680065-11
C...-63	5680015-02	5680065-12

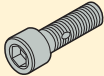
Spare Parts

For	Centre screw	Pin	Retaining nut
			
C...-32	5512067-01	3113020-304	5512091-04
C...-40	5512067-02	3113020-355	5512091-03
C...-50	5512067-03	3113020-406	5512091-01
C...-63	5512067-04	3113020-457	5512091-02



- The Seco-Capto™ machine side of short extensions can only be hold by spindles with segment clamping (not with centre bolt clamping)

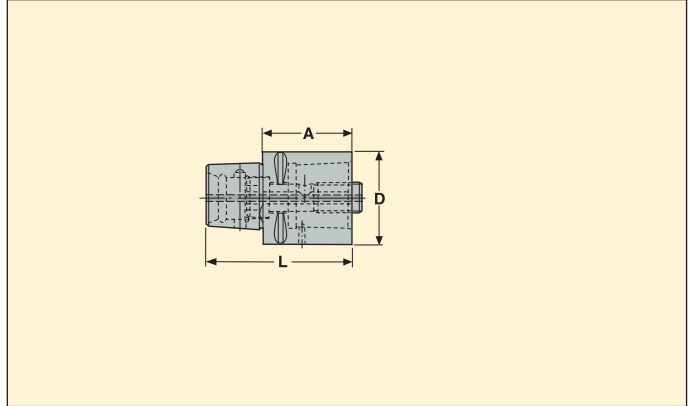

Seco-Capto™ shank	Seco-Capto™ receiver	Part No.	Dimensions in mm			
			A	D	L	
C3	C3	C3-391.01-32035	35	32	54	0,2
C4	C4	C4-391.01-40040	40	40	64	0,4
C5	C5	C5-391.01-50050	50	50	80	0,7
C6	C6	C6-391.01-63060	60	63	98	1,3
C8	C8	C8-391.01-80065	65	80	113	2,3

Please check availability in current price and stock-list

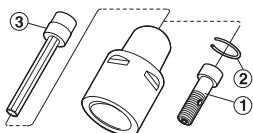



Accessories:
3 = Extension key

Spare Parts:
1 = Centre screw
2 = Circlip

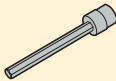
Accessories

For	Extension key
	
C...-32	5680015-05
C...-40	5680015-05
C...-50	5680015-05
C...-63	5680015-02
C...-80	5680015-02

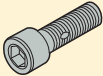
Spare Parts

For	Centre screw	Circlip
		
C...-32	5512068-01	5545040-02
C...-40	5512068-02	5545040-03
C...-50	5512068-03	5545040-07
C...-63	5512068-04	5545040-08
C...-80	5512068-05	5545040-08

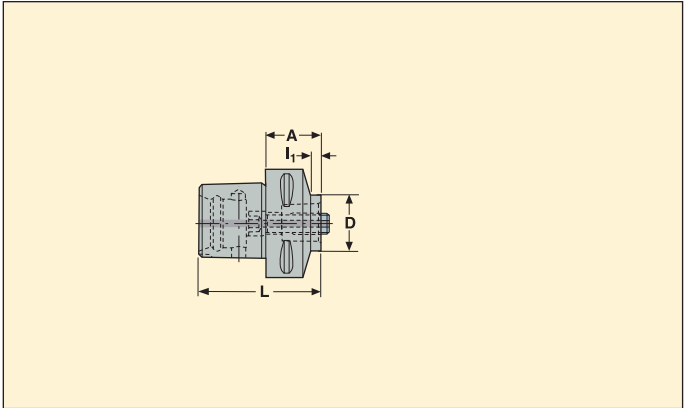

- The Seco-Capto™ machine side of short reducers can only be hold by spindles with segment clamping (not with centre bolt clamping)

Seco-Capto™ shank	Seco-Capto™ receiver	Part No.	Dimensions in mm				Balancing	
			A	D	L	I ₁		
C5	C3	C5-391.02-32033	33	32	63	10	-	0,5
	C4	C5-391.02-40040	40	40	70	18	-	0,6
C6	C3	C6-391.02-32032	32	32	70	6	-	0,9
	C4	C6-391.02-40040	40	40	78	11	-	0,9
	C5	C6-391.02-50050	50	50	88	24,5	-	1,0
C8	C5	C8-391.02-50045	45	50	93	10	-	1,9
	C6	C8-391.02-63055	55	63	103	20	-	2,1

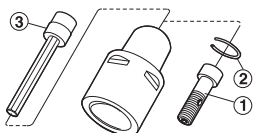



Accessories:
3 = Extension key

Spare Parts:
1 = Centre screw
2 = Circlip

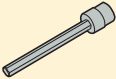
Accessories

For	Extension key
	
C5-391.02-32033	5680015-05
C5-391.02-40040	5680015-05
C6-391.02-32032	5680015-05
C6-391.02-40040	5680015-05
C6-391.02-50050	5680015-01
C8-391.02-50045	5680015-01
C8-391.02-63055	5680015-02

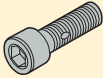
Spare Parts

For	Centre screw	Circlip
		
C5-391.02-32033	5512068-01	5545040-02
C5-391.02-40040	5512068-06	5545040-07
C6-391.02-32032	5512068-01	5545040-02
C6-391.02-40040	5512068-02	5545040-03
C6-391.02-50050	5512068-07	5545040-08
C8-391.02-50045	5512068-08	5545040-08
C8-391.02-63055	5512068-05	5545040-08

EPB 5545 – Shell mill holders, Accu-Fit™

Seco-Capto™/ ISO 26623-1

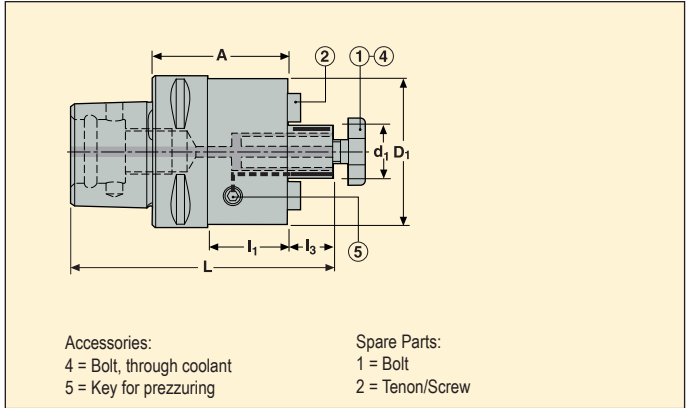

Seco-Capto™ shank	d ₁ mm	Part No.	Dimensions in mm					Balancing	KG
			A	D ₁	L	L ₁	L ₃		
C4	22	C4-391.5545-22050	50	48	93	30,0	19	1	0,7
	C5	22	C5-391.5545-22045	45	48	94	22,0	19	1
	27	C5-391.5545-27050	50	60	101	30,0	21	1	1,1
C6	22	C6-391.5545-22050	50	48	107	25,0	19	1	1,2
	27	C6-391.5545-27050	50	60	109	25,0	21	1	1,4
	32	C6-391.5545-32040	40	78	102	18,0	24	1	1,6
C8	27	C8-391.5545-27050	50	60	119	17,0	21	1	2,3
	32	C8-391.5545-32055	55	78	127	22,0	24	1	2,8
	40	C8-391.5545-40070	70	89	149	40,0	31	1	3,8

Accessories

For d ₁	Bolt, through coolant	Key	Spanner
22	5802210L	H04-4	5812210
27	5802712L	H04-4	5812712
32	5803216L	H04-4	5813216
40	5804020L	H04-4	5814020

Spare Parts

For d ₁	Bolt	Screw	Tenon
22	5802210	951D0416	16C2101111
27	5802712	951D0508	16C2121214
32	5803216	951D0516	16C2141421
40	5804020	951D0516	16C2161621

Please check availability in current price and stock-list



- With dynamic damping, ready to use

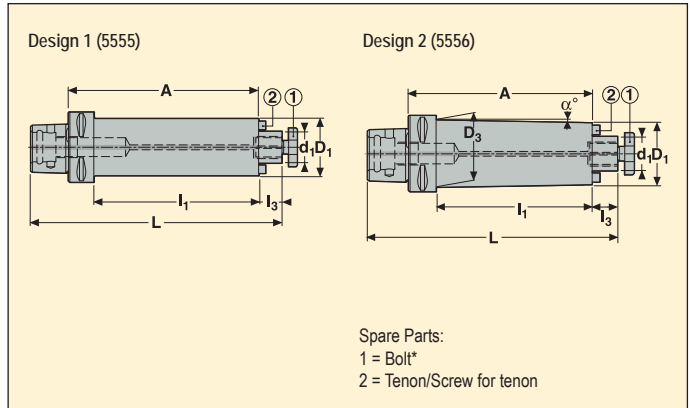

Seco-Capto™ shank	d ₁ mm	Part No.	Dimensions in mm						Design	α°	Balancing	KG
			A	D ₁	D ₃	L	I ₁	I ₃				
C6	16	C6-391.5555-16160	160	38	–	215	135	17	1	–	2	2,1
	22	C6-391.5555-22210	210	48	–	267	185	19	1	–	2	3,6
	22	C6-391.5556-22260	260	48	60	317	235	19	2	1,3	2	4,0
	27	C6-391.5555-27260	260	60	–	319	235	21	1	–	2	6,8
C8	22	C8-391.5555-22210	210	48	–	277	177	19	1	–	2	4,5
	22	C8-391.5556-22260	260	48	64	327	227	19	2	1,8	2	6,4
	27	C8-391.5555-27260	260	60	–	329	227	21	1	–	2	7,6
	27	C8-391.5556-27320	320	60	75	389	287	21	2	1,3	2	10,6
	32	C8-391.5555-32330	330	78	–	402	297	24	1	–	2	20,0
	40	C8-391.5555-40350	350	89	–	422	317	27	1	–	2	19,0

d₁ 40, includes 4 threaded holes on the bearing face according to DIN 6357

Accessories

For d ₁	Bolt, through coolant	Spanner
16	5801608L	5811608
22	5802210L	5812210
27	5802712L	5812712
32	5803216L	5813216
40	5804020L	5814020

Spare Parts*

For d ₁	Bolt	Screw	Tenon
16	5801608	951D0312	16C2080810A
22	5802210	951D0416	16C2101111
27	5802712	951D0516	16C2121214A
32	5803216	951D0516	16C2141421A
40	5804020	951D0616	16C2161621A

Please check availability in current price and stock-list

*These centre bolts are similar to the original delivered ones: check if lengths L are suitable for the milling cutters used, therefore see instructions in page(s) 29 or in the Operating instructions sheet delivered with the holders

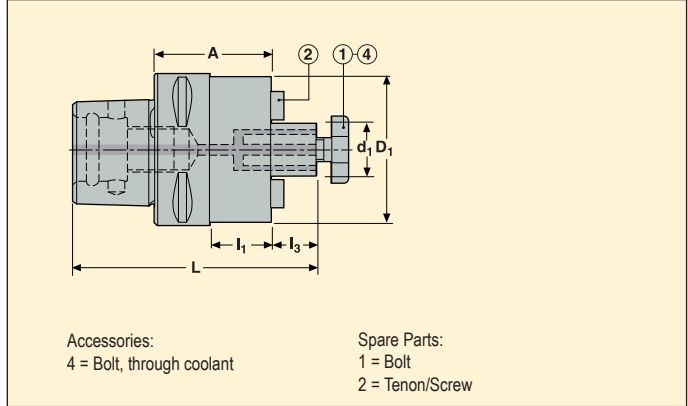

Seco-Capto™ shank	d ₁ mm	Part No.	Dimensions in mm					*	Balancing	
			A	D ₁	L	I ₁	I ₃			
C3	16	C3-391.5525-16030	30	38	66	15	17		1	0,27
C4	16	C4-391.5525-16035	35	38	76	12	17		1	0,4
	22	C4-391.5525-22040	40	48	83	20	19		1	0,58
C5	16	C5-391.5525-16035	35	38	82	12	17		1	0,6
	22	C5-391.5525-22040	40	48	89	17	19		1	0,76
	27	C5-391.5525-27040	40	60	91	20	21	*	1	0,95
	27	C5-391.5524-27040	40	48	91	17	21	*	1	0,8
C6	16	C6-391.5525-16035	35	38	90	10	17		1	0,92
	22	C6-391.5525-22040	40	48	97	15	19		1	1,09
	27	C6-391.5525-27040	40	60	99	15	21	*	1	1,24
	32	C6-391.5525-32040	40	78	102	18	24		1	1,6
	27	C6-391.5524-27040	40	48	99	15	21	*	1	1,12
C8	27	C8-391.5525-27050	50	60	119	17	21	*	1	2,29
	32	C8-391.5525-32050	50	78	122	17	24		1	2,64
	40	C8-391.5525-40055	55	89	130	25	27		1	3,06
	27	C8-391.5524-27050	50	48	119	17	21	*	1	2,14

* Diameter D₁ on type 5524 is smaller than on type 5525

Accessories

For d ₁	Bolt, through coolant	Spanner
16	5801608L	5811608
22	5802210L	5812210
27/5524	5802712L	5812712
27/5525	5802712L	5812712
32	5803216L	5813216
40	5804020L	5814020

Spare Parts

For d ₁	Bolt	Screw	Tenon
16	5801608	950D0312	16C10810164
22	5802210	950D0416	16C11012206
27/5524	5802712	951D0512	16C127
27/5525	5802712	951D0516	16C11214243
32	5803216	951D0516	16C2141421
40	5804020	951D0616	16C2161621

Please check availability in current price and stock-list

EPB 552 – Shell mill holders, small face – ISO 3937, without through coolant

Seco-Capto™/ISO 26623-1

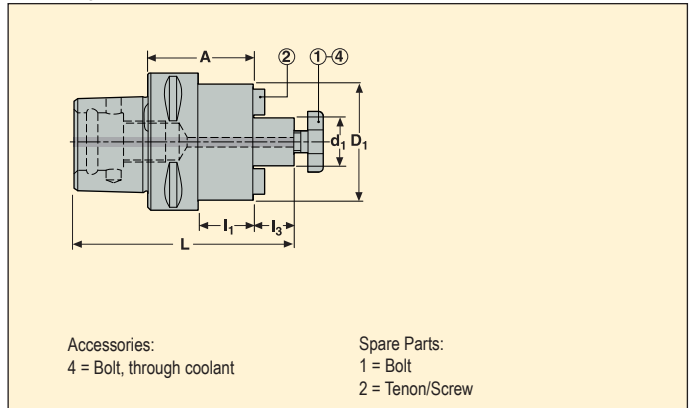

Seco-Capto™ shank	d ₁ mm	Part No.	Dimensions in mm					Balancing	
			A	D ₁	L	I ₁	I ₃		
C3	16	C3-391.0552-16030	30	32	66	15	17	1	0,2
C4	16	C4-391.0552-16032	32	32	73	9	17	1	0,4
	22	C4-391.0552-22055	55	40	98	35	19	1	0,7
C5	22	C5-391.0552-22070	70	40	119	47	19	1	1,0
	27	C5-391.0552-27035	35	48	86	12	21	1	0,8
C6	22	C6-391.0552-22035	35	40	92	10	19	1	1,0
	27	C6-391.0552-27035	35	48	94	10	21	1	1,1
	32	C6-391.0552-32035	35	58	97	10	24	1	1,2
C8	27	C8-391.0552-27035	35	48	104	2	21	1	1,9
	32	C8-391.0552-32035	35	58	107	2	24	1	2,0
	40	C8-391.0552-40035	35	70	110	2	27	1	2,2

Accessories

For d ₁	Bolt, through coolant	Spanner
16	5801608L	5811608
22	5802210L	5812210
27	5802712L	5812712
32	5803216L	5813216
40	5804020L	5814020

Spare Parts

For d ₁	Bolt	Screw	Tenon
16	5801608	950D0308	16C116
22	5802210	950D0410	16C122
27	5802712	951D0512	16C127
32	5803216	951D0514	16C132
40	5804020	951D0616	16C140

Please check availability in current price and stock-list

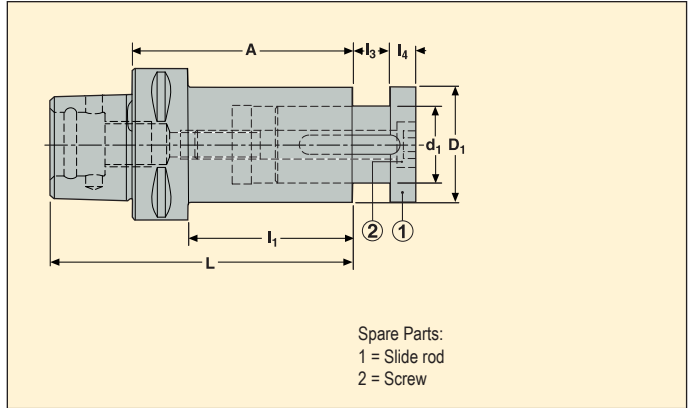

Seco-Capto™ shank	d ₁ mm	Part No.	Dimensions in mm						Balancing	
			A	D ₁	L	l ₁	l ₃	l ₄		
C4	22	C4-391.5657-22075	75	35	99	52	0-12	4	2	0,7
C5	22	C5-391.5657-22080	80	35	110	57	0-12	4	2	0,9
	27	C5-391.5657-27090	90	42	120	67	0-15	5	2	1,2
	32	C5-391.5657-32120	120	48	150	97	0-24	6	2	1,9
C6	22	C6-391.5657-22080	80	35	118	55	0-12	4	2	1,2
	27	C6-391.5657-27090	90	42	128	65	0-15	5	2	1,5
	32	C6-391.5657-32120	120	48	158	95	0-24	6	2	2,2
	40	C6-391.5657-40150	150	58	188	125	0-30	7	2	3,4
C8	27	C8-391.5657-27090	90	42	138	57	0-15	5	2	2,4
	32	C8-391.5657-32120	120	48	168	87	0-24	6	2	3,1
	40	C8-391.5657-40150	150	58	198	117	0-30	7	2	4,3
	50	C8-391.5657-50200	200	72	248	167	0-32	8	2	7,1
	60	C8-391.5657-60220	220	90	268	190	0-40	8	2	11,2

Spare Parts

For d ₁	Screw	Slide rod
22	19C565722	565722
27	19C565727	565727
32	950D1690	565732
40	19C565740	565740
50	19C565750	565750
60	19C565760	565760

Please check availability in current price and stock-list

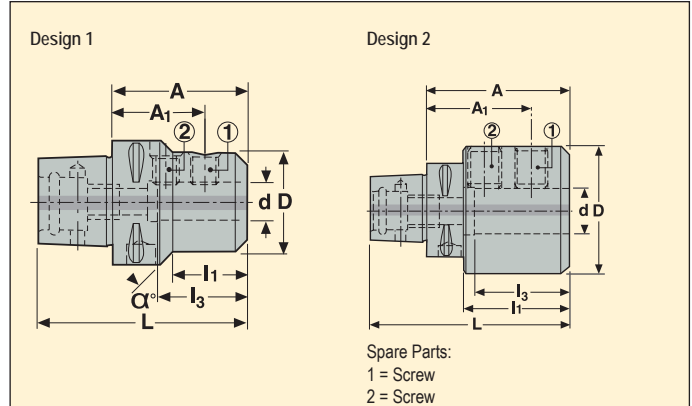

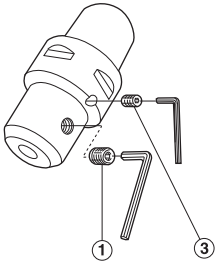

Seco-Capto™ shank	d mm	Part No.	Dimensions in mm						Design	α°	Balancing	KG
			A	D	L	A ₁	I ₁	I ₃				
C3	6	C3-391.20-06045A	46	25	65,0	28	27,5	27	1	30	2	0,3
	8	C3-391.20-08045A	46	28	65,0	28	29,0	30	1	45	2	0,3
	10	C3-391.20-10050	50	35	69,0	30	-	36	2	-	2	0,3
	12	C3-391.20-12055	55	42	74,0	32,5	-	40	2	-	2	0,5
C4	6	C4-391.20-06050	50	25	74,0	32	25,5	27	1	30	2	0,4
	8	C4-391.20-08050	50	28	74,0	32	26,5	30	1	45	2	0,4
	10	C4-391.20-10050A	51	35	75,0	31	29,6	36	1	30	2	0,5
	12	C4-391.20-12055A	56	42	80,0	33,5	-	43	2	-	2	0,6
	14	C4-391.20-14055	55	44	79,0	32,5	-	43	2	-	2	0,6
C5	6	C5-391.20-06050	50	25	80,0	32	25,5	27	1	20	2	0,5
	8	C5-391.20-08050	50	28	80,0	32	26,0	30	1	20	2	0,6
	10	C5-391.20-10055	55	35	85,0	35	27,5	36	1	45	2	0,7
	12	C5-391.20-12060	60	42	90,0	37,5	36,0	43	1	45	2	0,8
	14	C5-391.20-14060	60	44	90,0	37,5	37,0	43	1	45	2	0,8
	18	C5-391.20-18060	60	50	90,0	36	-	46	1	-	2	0,9
C6	6	C6-391.20-06055	55	25	93,0	37	25,0	27	1	22	2	0,9
	8	C6-391.20-08055	55	28	93,0	37	26,0	30	1	22	2	0,9
	10	C6-391.20-10060	60	35	98,0	40	30,0	36	1	30	2	1,1
	12	C6-391.20-12060	60	42	98,0	37,5	33,0	43	1	25	2	1,1
	14	C6-391.20-14060	60	44	98,0	37,5	33,5	43	1	25	2	1,2
	18	C6-391.20-18065	65	50	103,0	41,0	39,0	46	1	30	2	1,3
C8	6	C8-391.20-06070	70	25	118,0	52,0	27,0	27	1	25	2	2,0
	8	C8-391.20-08070	70	28	118,0	52,0	28,0	30	1	25	2	0,2
	10	C8-391.20-10070	70	35	118,0	50,0	29,5	36	1	25	2	2,2
	12	C8-391.20-12070	70	42	118,0	47,5	31,0	43	1	25	2	2,5
	14	C8-391.20-14070	70	44	118,0	47,5	31,6	43	1	25	2	2,2
	18	C8-391.20-18070	70	50	118,0	46	33,0	46	1	25	2	2,2
	50	C8-391.20-50120	120	100	168,0	85	-	78	2	-	2	6,0

Please check availability in current price and stock-list



Spare Parts:
 1 = Screw
 3 = Screw

Spare Parts

For d	Locking screw 1	Locking screw 2
		
6	3214050-357	-
8	3214050-407	-
10	3214050-458	-
12	3214050-509	-
14	3214050-509	-
18	3214050-539	-
50	3214050-661	3214050-611



Design 1

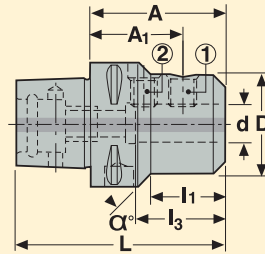

Design 2

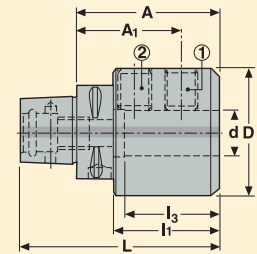

Spare Parts:
1 = Screw
2 = Screw

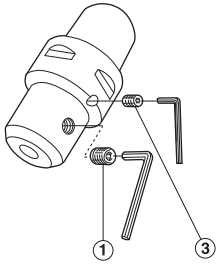

Seco-Capto™ shank	d mm	Part No.	Dimensions in mm						Design	α°	Balancing	KG
			A	D	L	A ₁	I ₁	I ₃				
C4	16	C4-391.0584-16055	55	48	79,0	31	35,0	46	2	–	2	0,6
C5	16	C5-391.0584-16060	60	48	90,0	36	37,0	46	1	45	2	0,9
	20	C5-391.0584-20060	60	52	90,0	35	–	48	2	–	2	0,9
	25	C5-391.0584-25080	80	63	110,0	56	–	54	2	–	2	1,5
C6	16	C6-391.0584-16065	65	48	103,0	41	40,0	51	1	0	2	1,3
	20	C6-391.0584-20065	65	52	103,0	40	40,0	48	1	0	2	1,3
	25	C6-391.0584-25080	80	63	118,0	56	–	54	1	–	2	0,8
	32	C6-391.0584-32090	90	72	128,0	66	–	58	2	–	2	2,4
	40	C6-391.0584-40100	100	80	138,0	70	–	68	2	–	2	2,9
C8	16	C8-391.0584-16070	70	48	118,0	46	37,0	46	1	0	2	2,2
	20	C8-391.0584-20070	70	52	118,0	45	37,0	48	1	0	2	2,2
	25	C8-391.0584-25080	80	65	128,0	56	47,0	54	1	0	2	2,7
	32	C8-391.0584-32080	80	72	128,0	56	47,0	58	1	0	2	2,7
	40	C8-391.0584-40110	110	80	158,0	80	–	68	1	–	2	3,9

Please check availability in current price and stock-list



Spare Parts:
1 = Screw

Spare Parts

For d	Locking screw	Locking screw 1
		
16	–	951C1416
20	–	951C1616
25	951C1820	951C1820
32	951C2020	951C2020
40	951C2020	951C2020

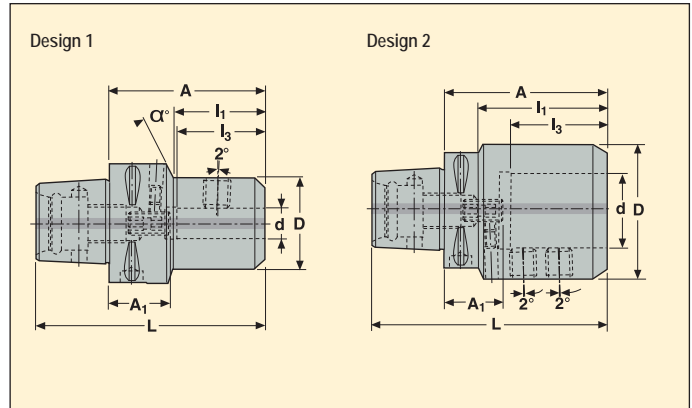



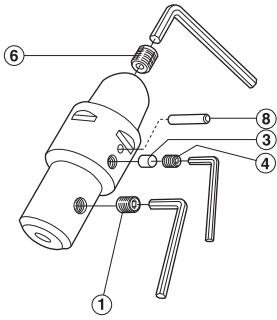

Seco-Capto™ shank	d mm	Part No.	Dimensions in mm						Design	α°	Balancing	KG
			A	D	L	A ₁ min-max	l ₁	l ₃				
C3	6	C3-391.21-06070A	70	25	89	32-40	37	30	1	45	2	0,4
	8	C3-391.21-08070A	70	28	89	32-40	40	30	1	45	2	0,4
	10	C3-391.21-10070	70	35	89	28-38	-	39	1	-	2	0,5
	12	C3-391.21-12075	75	42	94	28-40	-	44	2	-	2	0,7
C4	6	C4-391.21-06070A	70	25	94	32-40	37	30	1	30	2	0,5
	8	C4-391.21-08070A	70	28	94	32-40	37	30	1	30	2	0,5
	10	C4-391.21-10070	70	35	94	28-38	39	-	1	30	2	0,6
	12	C4-391.21-12075	75	42	99	28-40	-	44	2	-	2	0,8
	14	C4-391.21-14075	75	44	99	28-40	-	44	2	-	2	0,8
C5	6	C5-391.21-06070A	70	25	100	32-40	37	30	1	15	2	0,7
	8	C5-391.21-08070A	70	28	100	32-40	37	30	1	15	2	0,8
	10	C5-391.21-10070	70	35	100	28-38	38	39	1	15	2	0,9
	12	C5-391.21-12075	75	42	105	28-40	43	44	1	30	2	1,0
	14	C5-391.21-14075	75	44	105	28-40	44	44	1	30	2	1,1
	16	C5-391.21-16080	80	48	110	30-42	48	47	1	45	2	1,2
	18	C5-391.21-18080	80	50	110	30-42	-	47	1	-	2	1,2
20	C5-391.21-20085	85	52	115	33-45	-	49	2	-	2	1,3	
C6	6	C6-391.21-06075A	75	25	113	37-45	35	30	1	15	2	1,2
	8	C6-391.21-08075A	75	28	113	37-45	35	30	1	15	2	1,3
	10	C6-391.21-10075	75	35	113	33-43	36	39	1	15	2	1,4
	12	C6-391.21-12080	80	42	118	33-45	42	44	1	15	2	1,5
	14	C6-391.21-14080	80	44	118	33-45	42	44	1	15	2	1,6
	16	C6-391.21-16080	80	48	118	30-42	47	47	1	15	2	1,6
	18	C6-391.21-18080	80	50	118	30-42	47	47	1	15	2	1,6
	20	C6-391.21-20085	85	52	123	33-45	51	49	1	15	2	1,7
	25	C6-391.21-25090	90	65	128	32-44	-	54	2	-	2	2,3
32	C6-391.21-32095	95	72	133	33-45	-	58	2	-	2	2,5	
C8	6	C8-391.21-06065A	65	25	113	27-35	25	30	1	20	2	2,1
	8	C8-391.21-08065A	65	28	113	27-35	25,5	30	1	20	2	2,2
	10	C8-391.21-10065	65	35	113	23-33	27	39	1	20	2	2,0
	12	C8-391.21-12070	70	42	118	23-35	33	44	1	20	2	2,1
	14	C8-391.21-14070	70	44	118	23-35	33,5	44	1	20	2	2,2
	16	C8-391.21-16075	75	48	123	25-37	39	47	1	20	2	2,4
	18	C8-391.21-18075	75	50	123	25-37	39,5	47	1	20	2	2,5
	20	C8-391.21-20080	80	52	128	28-40	45	49	1	15	2	2,5
	25	C8-391.21-25090	90	65	138	32-44	57	54	1	20	2	3,0
	32	C8-391.21-32095	95	72	143	33-45	63	58	1	20	2	3,0

Please check availability in current price and stock-list



- Spare Parts:
 1 = Screw
 2 = Plug
 3 = Plug
 4 = Screw
 5 = Screw
 6 = Screw
 7 = Pin
 8 = Screw
 9 = Pin

Spare Parts

For	Locking screw 1 	Locking screw 2 	Pin 	Stop screw 
C...-10	3214050-458	3214010-355	-	5512066-03
C...-12	3214050-509	3214010-357	-	5512066-05
C...-14	3214050-509	3214010-357	-	5512066-05
C...-16	3214050-539	3214010-357	-	5512066-06
C...-18	3214050-539	3214010-357	-	5512066-06
C...-20	3214050-559	3214010-357	-	5512066-07
C...-25	3214050-590	3214010-357	-	5512066-07
C...-32	3214050-610	3214010-357	-	5512066-07
C3...-06070	3214050-357	3214010-355	3113020-459	5512066-01
C3...-08070	3214050-407	3214010-355	3113020-459	5512066-02
C4...-06070	3214050-357	3214010-355	3113020-461	5512066-01
C4...-08070	3214050-407	3214010-355	3113020-461	5512066-02
C5...-06070	3214050-357	3214010-355	3113020-463	5512066-01
C5...-08070	3214050-407	3214010-355	3113020-463	5512066-02
C6...-06075	3214050-357	3214010-355	3113020-465	5512066-01
C6...-08075	3214050-407	3214010-355	3113020-465	5512066-02
C8...-06065	3214050-357	3214010-355	3113020-465	5512066-01
C8...-08065	3214050-407	3214010-355	3113020-465	5512066-02

EPB 27 – Side lock holders

Seco-Capto™/ISO 26623-1

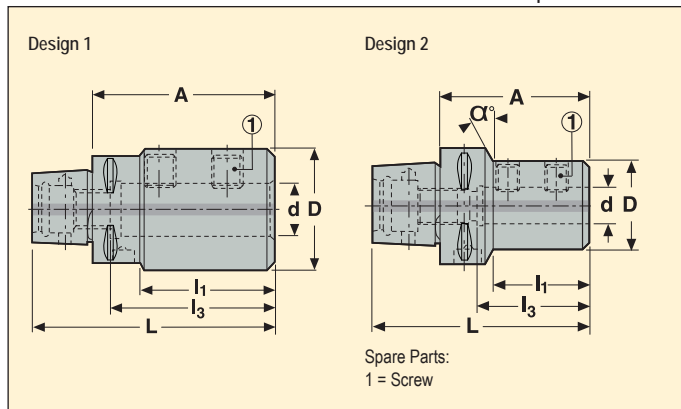

Seco-Capto™ shank	d mm	Part No.	Dimensions in mm					Design	α°	Balancing	KG
			A	D	L	I ₁	I ₃				
C3	16	C3-391.27-16056	56	36	75	41,0	49,5	1	60	2	0,4
	20	C3-391.27-20060	60	40	79	45,0	51,5	1	–	2	0,4
C4	16	C4-391.27-16056	56	36	80	32,5	49,5	2	60	2	0,5
	20	C4-391.27-20060	60	40	84	–	51,5	2	–	2	0,5
	25	C4-391.27-25077	77	45	101	57,0	57,5	1	–	2	0,7
C5	16	C5-391.27-16065	65	36	95	41,7	49,5	2	25	2	0,7
	20	C5-391.27-20060	60	40	90	37,7	51,5	2	25	2	0,7
	25	C5-391.27-25071	71	45	101	46,7	62,5	2	60	2	0,8
	32	C5-391.27-32075	75	52	105	55,0	61,5	1	–	2	0,9
C6	16	C6-391.27-16070	70	36	108	43,0	49,5	2	20	2	1,1
	20	C6-391.27-20070	70	40	108	43,8	51,5	2	20	2	1,1
	25	C6-391.27-25070A	72	45	110	45,8	59,5	2	25	2	1,2
	32	C6-391.27-32075	75	52	113	49,8	61,5	2	30	2	1,3
	40	C6-391.27-40085	85	65	123	63,0	71,5	1	–	2	1,7
C8	16	C8-391.27-16080	80	36	128	42,0	49,5	2	20	2	2,1
	20	C8-391.27-20080	80	40	128	43,8	51,5	2	17	2	2,2
	25	C8-391.27-25085	85	45	133	49,8	57,5	2	17	2	2,2
	32	C8-391.27-32090	90	52	138	53,8	61,5	2	14	2	2,4
	40	C8-391.27-40095	95	65	143	62,8	71,5	2	17	2	2,7

Please check availability in current price and stock-list
 A Programming length for Performax® drills
 I₁ Programming length for Feedmax™ drills

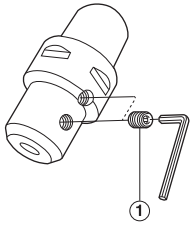

Spare Parts:
1 = Screw

Spare Parts

For d	Locking screw
16	5514042-04
20	5514042-04
25	416.1-838
32	416.1-838
40	5514042-06

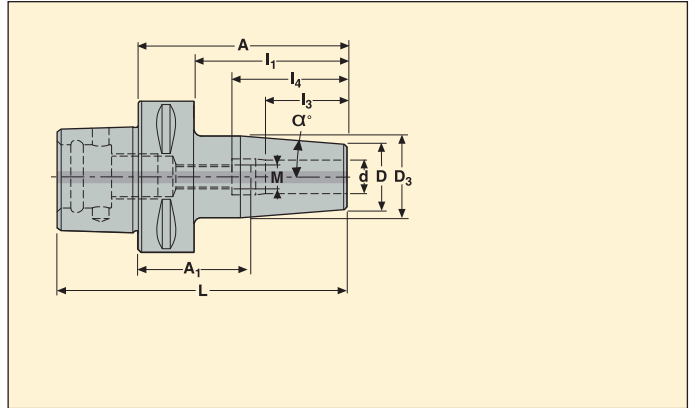

Seco-Capto™ shank	d mm	Part No.	Dimensions in mm									Balancing	
			A	D	D ₃	L	I ₁	I ₃	I ₄	A ₁ min-max	M		
C3	6	C3-391.5603-06065	65	21	27	84	47	22	37,5	29-39	M5	1	0,3
	8	C3-391.5603-08065	65	21	27	84	47	26	37,5	29-39	M6	1	0,3
	10	C3-391.5603-10070	70	24	32	89	52	31	42,5	29-39	M8x1	1	0,4
	12	C3-391.5603-12070	70	24	32	89	52	34	42,5	24-34	M10x1	1	0,4
C4	6	C4-391.5603-06075	75	21	27	99	52	22	37,5	39-39	M5	1	0,5
	8	C4-391.5603-08075	75	21	27	99	52	26	37,5	39-39	M6	1	0,5
	10	C4-391.5603-10075	75	24	32	99	52	31	42,5	34-44	M8x1	1	0,5
	12	C4-391.5603-12075	75	24	32	99	52	34	47,5	29-39	M10x1	1	0,5
	14	C4-391.5603-14080	80	27	34	104	57	34	47,5	34-44	M10x1	1	0,6
	16	C4-391.5603-16080	80	27	34	104	57	39	50,5	31-41	M12x1	1	0,6
C5	6	C5-391.5603-06075	75	21	27	105	52	22	37,5	39-49	M5	1	0,7
	8	C5-391.5603-08075	75	21	27	105	52	26	37,5	39-49	M6	1	0,6
	10	C5-391.5603-10075	75	24	32	105	52	31	42,5	34-44	M8x1	1	0,7
	12	C5-391.5603-12075	75	24	32	105	52	34	47,5	29-39	M10x1	1	0,7
	14	C5-391.5603-14080	80	27	34	110	57	34	47,5	34-44	M10x1	1	0,7
	16	C5-391.5603-16080	80	27	34	110	57	39	50,5	31-41	M12x1	1	0,7
	18	C5-391.5603-18080	80	33	42	110	57	39	50,5	31-41	M12x1	1	0,9
	20	C5-391.5603-20085	85	33	42	115	62	41	52,5	34-44	M16x1	1	0,9
	25	C5-391.5603-25090	90	44	53	120	70	47	58,5	33-43	M16x1	1	1,2
C6	6	C6-391.5603-06080	80	21	27	118	55	22	37,5	44-54	M5	1	1,0
	8	C6-391.5603-08080	80	21	27	118	55	26	37,5	44-54	M6	1	1,0
	10	C6-391.5603-10080	80	24	32	118	55	31	42,5	39-49	M8x1	1	1,1
	12	C6-391.5603-12080	80	24	32	118	55	34	47,5	34-44	M10x1	1	1,1
	14	C6-391.5603-14085	85	27	34	123	60	34	47,5	39-49	M10x1	1	1,1
	16	C6-391.5603-16085	85	27	34	123	60	39	50,5	36-46	M12x1	1	1,1
	18	C6-391.5603-18085	85	33	42	123	60	39	50,5	36-46	M12x1	1	1,3
	20	C6-391.5603-20085	85	33	42	123	60	41	52,5	34-44	M16x1	1	1,2
	25	C6-391.5603-25090	90	44	53	128	65	47	58,5	33-43	M16x1	1	1,5
	32	C6-391.5603-32095	95	44	53	133	70	51	62,5	34-44	M16x1	1	1,4
C8	16	C8-391.5603-16090	90	27	34	138	57	39	50,5	41-51	M12x1	1	2,1
	18	C8-391.5603-18090	90	33	42	138	57	39	50,5	41-51	M12x1	1	2,2
	20	C8-391.5603-20090	90	33	42	138	57	41	52,5	39-49	M16x1	1	2,1
	25	C8-391.5603-25090	90	44	53	138	57	47	58,5	33-43	M16x1	1	2,4
	32	C8-391.5603-32090	90	44	53	138	57	51	62,5	29-39	M16x1	1	2,3

Please check availability in current price and stock-list
No fine tune balancing threaded holes

Spare Parts

For d	Stop screw 
6	19BDR05165
8	19BDR06165
10	19BDR08165
12-14	19BDR10165
16-18	19BDR12165
20-32	19BDR16165

EPB 5600 – Shrinkfit holders, reinforced

Seco-Capto™/ISO 26623-1



- Reinforced design with wider front and tapered body
- Run-out 3 μm maximum at 3rd
- With coolant supply channels towards the tool (plugged)

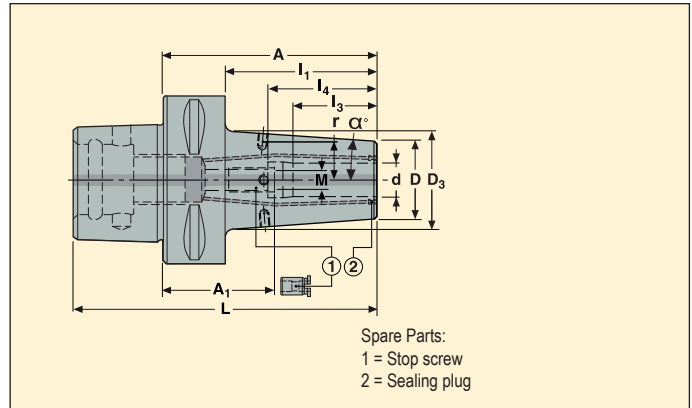

Seco-Capto™ shank	d mm	Part No.	Dimensions in mm								M mm	r mm	α°	Balancing	KG
			A*	D	D ₃	L	L ₁	L ₃	L ₄	A ₁ min-max					
C6	12	C6-391.5600-12080	80	27	35,6	118	55	34	47,5	34-44	M10x1	13,5	4,5	1	1,2
	16	C6-391.5600-16085	85	33	42,4	123	60	39	50,5	36-46	M12x1	17,0	4,5	1	1,3
	20	C6-391.5600-20085	85	44	53,4	123	60	41	52,5	34-44	M16x1	21,5	4,5	1	1,6
	25	C6-391.5600-25090	90	48	58,2	128	65	47	58,5	33-43	M16x1	25,0	4,5	1	1,8
C8	16	C8-391.5600-16095	95	33	42,7	143	62	39	50,5	46-56	M12x1	17,0	4,5	1	2,3
	20	C8-391.5600-20095	95	44	53,7	143	62	41	52,5	44-54	M16x1	21,5	4,5	1	2,6
	25	C8-391.5600-25100	100	48	58,5	148	67	47	58,5	43-53	M16x1	25,0	4,5	1	2,8

* C6-391.5600-25090 and C8-391.5600-25100: Extra-short holder requiring a dedicated cooling contact bush type "5600 extra short", see page(s) 337

Accessories

For d	Balancing screws
12	90ZQ01
16	90ZQ01
20-25	90ZQ01

Spare Parts

For d	Sealing plugs	Stop screw
12	90AI03	19BDR10165
16	90AI03	19BDR12165
20-25	90AI04	19BDR16165

Please check availability in current price and stock-list
For stop screw setting adapters, see page(s) 336



- With Safe-Lock™ tool pull-out protection system
- Reinforced design of EPB 5600
- Run-out 3 µm maximum at 3xd
- With coolant supply channels towards the tool (plugged)

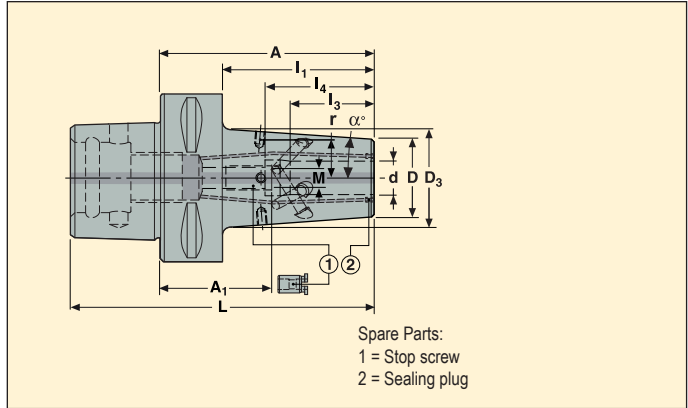

Seco-Capto™ shank	d mm	Part No.	Dimensions in mm								M mm	r mm	α°	Balancing	
			A	D	D ₃	L	I ₁	I ₃	I ₄	A ₁ min-max					
C6	12	C6-391.5600-12080P	80	27	35,6	118	55	34	47,5	34-42,5	M10x1	13,5	4,5	1	1,2
	16	C6-391.5600-16085P	85	33	42,4	123	60	39	50,5	36-44	M12x1	17,0	4,5	1	1,3
	20	C6-391.5600-20085P	85	44	53,4	123	60	41	52,5	34-42	M16x1	21,5	4,5	1	1,6
	25	C6-391.5600-25090P	90	48	58,2	128	65	47	58,5	33-41	M16x1	25,0	4,5	1	1,8
C8	16	C8-391.5600-16095P	95	33	42,7	143	62	39	50,5	46-54	M12x1	17,0	4,5	1	2,3
	20	C8-391.5600-20095P	95	44	53,7	143	62	41	52,5	44-52	M16x1	21,5	4,5	1	2,6
	25	C8-391.5600-25100P	100	48	58,5	148	67	47	58,5	43-51	M16x1	25,0	4,5	1	2,8

Accessories

For d	Balancing screws
12	90ZQ01
16	90ZQ01
20	90ZQ01
25	90ZQ01

Spare Parts

For d	Sealing plugs	Stop screw
12	90AI03	–
16	90AI03	–
20	90AI04	19BDR16165
25	90AI04	19BDR16165

Please check availability in current price and stock-list

(-) For Ø 12 and 16 mm, stop screw not removable/replaceable by the user, please request a repair process



- Run-out 4 µm maximum at 3xd

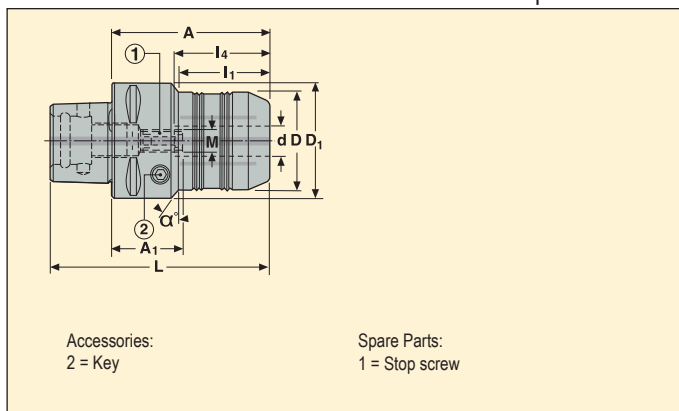

Seco-Capto™ shank	d mm	Part No.	Dimensions in mm							M mm	α°	Balancing	
			A	D	D ₁	L	L ₁	L ₄	A ₁ min-max				
C6	12	C6-391.5835-12075	75	48	63	113	38,5	47	28-38	M10	30	1	1,53
	20	C6-391.5835-20080	80	63	63	118	-	52	28-38	M10	-	1	1,96
C8	20	C8-391.5835-20090	90	63	80	138	57,0	52	38-48	M10	0	1	3,00
	32	C8-391.5835-32090	90	80	80	138	-	63	27-37	M10	-	1	3,57

For reduction sleeves and control gauges, see page(s) 295-296

Accessories

For d	Locking key
12	03HXL06
20	03HXL06
32	03HXL06

Spare Parts

For d	Stop screw
12	19LS1016A
20	19LS1016A
32	19LS1016A

Please check availability in current price and stock-list

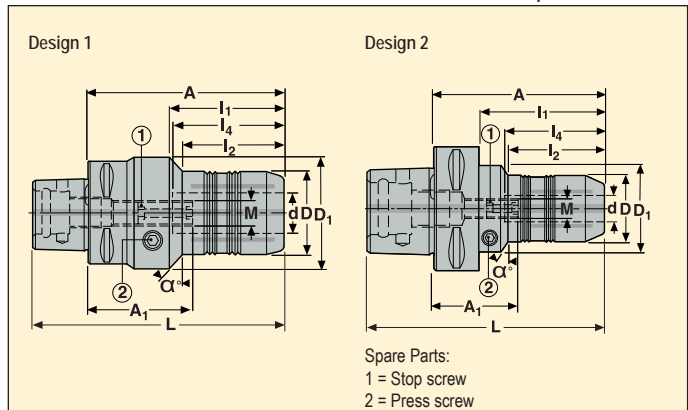

Seco-Capto™ shank	d mm	Part No.	Dimensions in mm									Design	α°	Balancing	
			A	D	D ₁	L	I ₁	I ₂	I ₄	A ₁ min-max	M				
C4	12	C4-391.5834-12085	85	32	50	109	45,2	40	47	48-38	M10	1	30	1	0,8
C5	6	C5-391.5834-06065	65	26	50	95	-	23	38	37-27	M5	2	30	1	0,8
	8	C5-391.5834-08065	65	28	50	95	-	24	38	37-27	M5	2	30	1	0,9
	10	C5-391.5834-10075	75	30	50	105	-	34	42	43-33	M8	2	30	1	0,8
	12	C5-391.5834-12080	80	32	50	110	-	40	47	43-33	M10	2	30	1	0,9
	14	C5-391.5834-14080	80	34	50	110	-	40	47	43-33	M10	2	30	1	0,9
	16	C5-391.5834-16085	85	38	50	115	-	46	50	45-35	M10	2	30	1	1,0
	20	C5-391.5834-20085	85	42	50	115	-	47	52	43-33	M10	2	30	1	1,0
	25	C5-391.5834-25095	95	58	58	125	-	-	58	47-37	M10	1	-	1	1,6
C6	06	C6-391.5834-06065	65	26	50	103	40,0	23	38	37-27	M5	2	30	1	1,1
	08	C6-391.5834-08065	65	28	50	103	40,0	24	38	37-27	M5	2	30	1	1,1
	10	C6-391.5834-10075	75	30	50	113	50,0	34	42	43-33	M8	2	30	1	1,2
	12	C6-391.5834-12080	80	32	50	118	55,0	40	47	43-33	M10	2	30	1	1,2
	16	C6-391.5834-16085	85	38	50	123	60,0	46	50	45-35	M10	2	30	1	1,3
	20	C6-391.5834-20085	85	42	50	123	60,0	47	52	43-33	M10	2	30	1	1,3
	25	C6-391.5834-25095	95	58	58	133	70,0	-	58	47-37	M10	2	-	1	0,6
	32	C6-391.5834-32100	100	64	64	138	-	-	63	47-37	M10	1	-	1	2,2
C8	20	C8-391.5834-20095	95	42	50	143	62,0	52	52	53-43	M10	2	30	1	2,4
	32	C8-391.5834-32105	105	64	70	153	72,0	60	63	52-42	M10	2	30	1	3,2

Please check availability in current price and stock-list
For reduction sleeves and control gauges, please see page(s) 295-296

Accessories

For d	Locking key
	
6-8	H04-4
10	H04-4
12	H04-4
14-32	H04-4

Spare Parts

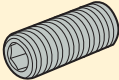
For d	Press screw	Stop screw
		
6-8	950AF0810008	19LS0512A
10	950AF0810008	19LS0816A
12	950AF0810008	19LS1016A
14-32	950AF1010010	19LS1016A

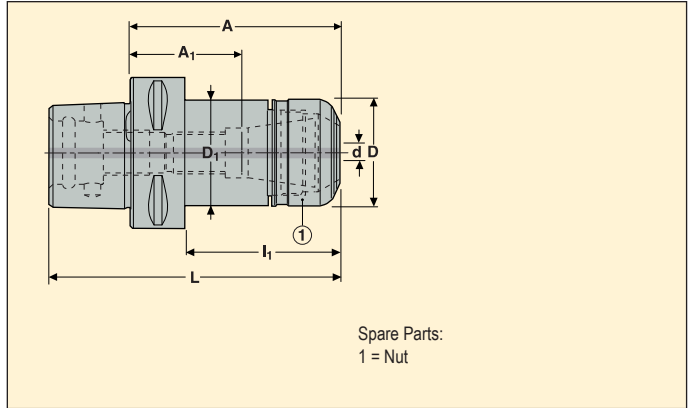

Seco-Capto™ shank	d mm	Part No.	Chuck & Collet Size	Dimensions in mm						A ₁ min-max*	**	Balancing	
				A	D	D ₁	L	I ₁					
C3	1-7	C3-391.5672-11045	HP 11	45	16	16	64	27	6-27	**	1	0,2	
	1-10	C3-391.5672-16045R	HP 16R	45	24	24	64	27	6-17,5	**	1	0,18	
	1-10	C3-391.5672-16060	HP 16	60	30	30	79	42	20-30		1	0,3	
C4	1-7	C4-391.5672-11045	HP 11	45	16	16	69	22	6-27	**	1	0,3	
	1-10	C4-391.5672-16045R	HP 16R	45	24	24	69	22	6-17,5	**	1	0,31	
	1-10	C4-391.5672-16060	HP 16	60	30	30	84	37	20-30		1	0,42	
C5	1-10	C5-391.5672-16065	HP 16	65	30	30	95	42	23-35		1	0,64	
	2-16	C5-391.5672-25085	HP 25	85	40	40	115	62	41-47		1	0,88	
C6	1-10	C6-391.5672-16075	HP 16	75	30	30	113	50	30-45		1	1,03	
	2-16	C6-391.5672-25090	HP 25	90	40	40	128	65	40-52		1	1,25	
C8	2-16	C8-391.5672-25100	HP 25	100	40	40	148	67	40-62		1	2,28	
	2-20	C8-391.5672-32100	HP 32	100	50	50	148	67	36-52		1	2,52	

For ER HP collets type 5672, see page(s) 297-300, Chuck size HP 16R use the collet size ER HP 16

* A1 setting length onto stop screw when possible, or total available setting length for chucks without thread for stop end screw. ** Chuck without thread for stop screw

Accessories***

For size	Socket	Spanner	Stop screw	Torque key
HP 11	03EF567211	03B567211	–	03DYD010100
HP 16	03EF567216	03B567216	19B58711	03DYD010100
HP 16R	03EF567216R	03B567216R	–	03DYD010100
HP 25	03EF567225	03B567225	19B58718	03DYD020200
HP 32	03EF567232	03B567232	19B58722	03DYD020200

Spare Parts

For size	Nut
HP 11	08B567211
HP 16	08B567216
HP 16R	08B567216R
HP 25	08B567225
HP 32	08B567232

Please check availability in current price and stock-list

*** When using a stop screw, its tapered contact onto the tool shank can increase the tool run-out defect. For tightening torques, see Guide pages

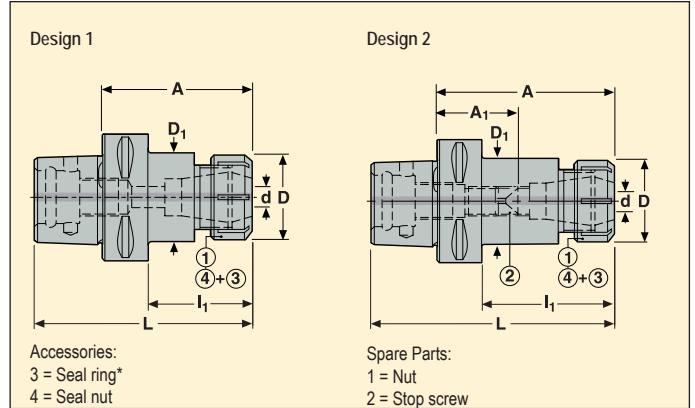

Seco-Capto™ shank	ER		Part No.	Dimensions in mm						Design	Balancing	
	Size	Capacity d mm		A	D	D ₁	L	I ₁	A ₁ min-max			
C3	ER 16	0,5-10	C3-391.5675-16045	45	32	–	64	27	–	1	1	0,2
C4	ER 25	1-16	C4-391.5675-25052	52	42	–	76	29	–	1	1	0,4
	ER 32	2-20	C4-391.5675-32054	54	50	–	78	–	–	1	1	0,4
C5	ER 25	1-16	C5-391.5675-25055	55	42	42	85	32	–	1	1	0,6
	ER 25	1-16	C5-391.5675-25100	100	42	42	130	77	31-62	2	1	1,0
	ER 32	2-20	C5-391.5675-32057	57	50	–	87	32	–	1	1	0,7
C6	ER 16	0,5-10	C6-391.5675-16100	100	32	32	138	75	52-68	2	1	1,2
	ER 25	1-16	C6-391.5675-25060	60	42	42	98	35	–	1	1	1,0
	ER 25	1-16	C6-391.5675-25100	100	42	42	138	75	31-62	2	1	1,4
	ER 25	1-16	C6-391.5675-25130	130	42	42	168	105	61-92	2	1	1,7
	ER 25	1-16	C6-391.5675-25160	160	42	42	198	135	91-122	2	1	2,0
	ER 32	2-20	C6-391.5675-32060	60	50	50	98	35	–	1	1	1,0
	ER 32	2-20	C6-391.5675-32100	100	50	50	138	78	32-60	2	1	1,6
	ER 32	2-20	C6-391.5675-32130	130	50	50	168	108	62-90	2	1	2,0
C8	ER 40	3-26	C6-391.5675-40065	65	63	–	103	45	–	1	1	1,2
	ER 32	2-20	C8-391.5675-32070	70	50	50	118	37	23-30	2	1	2,1
			C8-391.5675-32160	160	50	50	208	130	92-120	2	1	3,3
			C8-391.5675-40070	70	63	–	118	37	23-30	2	1	2,1

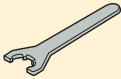

Please check availability in current price and stock-list
 For ER type collets, please see page(s) 302-303

Accessories*

For size	Seal nut	Spanner
		
ER 16	08B587516IC	03B587516
ER 25	08B587525IC	03B587525
ER 32	08B587532IC	03B587532
ER 40	08B587540IC	03B587540

* For ER type Sealing rings, please see page(s) 304

Spare Parts

For size	Nut	Stop screw
		
ER 16	08B587516X	19B58711
ER 25	08B587525X	19B58718
ER 32	08B587532X	19B58722
ER 40	08B587540X	19B58730



- Inbuilt axial micro flexure (+/- 0,5 mm) prevents from tapping tap stress
- Tap fitting based on ER tapping collets with square drive
- Maximum coolant pressure 80 bar

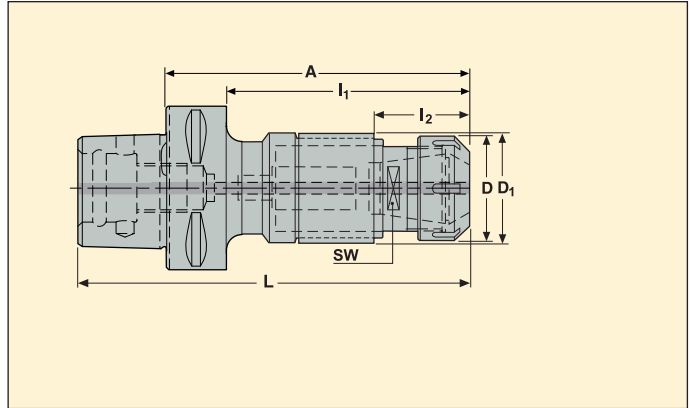

Seco-Capto™ shank	Tapping range	Size	Part No.	Dimensions in mm								Balancing	
				A	D	D ₁	L	I ₁	I ₂	SW			
C4	M2-M5	ER 11	C4-391.5867-11080	80,0	18,7	23,5	104,0	60,0	24,1	12,7	-	0,4	
	M4-M12	ER 20	C4-391.5867-20102	102,2	33,7	35,0	126,2	82,0	40,3	22,0	-	0,7	
	M8-M20	ER 25	C4-391.5867-25122	121,6	42,0	44,0	145,6	101,6	42,1	28,0	-	1,1	
C5	M4-M12	ER 20	C5-391.5867-20103	102,7	33,7	35,0	132,7	82,7	40,3	22,0	-	0,9	
	M8-M20	ER 25	C5-391.5867-25122	122,1	42,0	44,0	152,1	102,1	42,1	28,0	-	1,3	
	M16-M30	ER 40	C5-391.5867-40154	154,0	62,7	62,0	184,0	134,0	52,0	39,7	-	2,8	
C6	M4-M12	ER 20	C6-391.5867-20105	104,7	33,7	35,0	142,7	82,7	40,3	22,0	-	1,2	
	M8-M20	ER 25	C6-391.5867-25124	124,1	42,0	44,0	162,1	102,1	42,1	28,0	-	1,6	
	M16-M30	ER 40	C6-391.5867-40154	153,5	62,7	62,0	191,5	131,5	52,0	39,7	-	2,9	
C8	M4-M12	ER 20	C8-391.5867-20112	111,7	33,7	35,0	159,7	81,7	40,3	22,0	-	2,2	
	M8-M20	ER 25	C8-391.5867-25131	131,1	42,0	44,0	179,1	101,1	42,1	28,0	-	2,6	
	M16-M30	ER 40	C8-391.5867-40161	160,5	62,7	62,0	208,5	130,5	52,0	39,6	-	3,9	

For ER tapping collets with square drive, see page(s) 308

Accessories

For size	Locking key	Spanner
ER 11	5680092-03	03B587511UM
ER 20	5680092-04	03B587520UM
ER 25	5680092-05	03B587525
ER 40	5680092-06	03B587540

Spare Parts

For size	Nut
ER 11	5533050-07
ER 20	5533051-02
ER 25	5533051-03
ER 40	5533051-05

Please check availability in current price and stock-list
 For EPB 5867 sealing rings, see page(s) 309

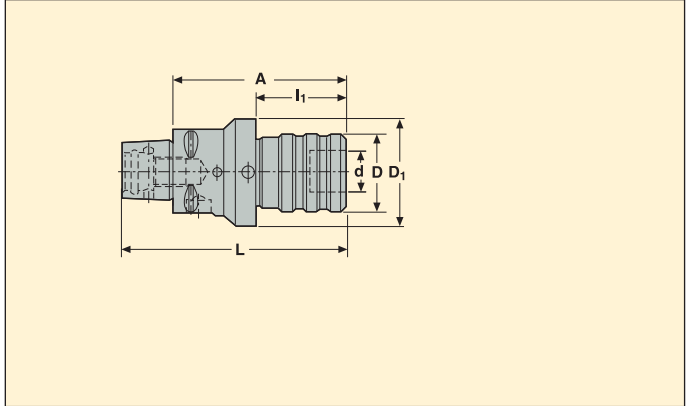

Seco-Capto™ shank	Tapping range	Part No.	For tap adapter		Length compensation mm compression/ extension	Dimensions in mm					Balancing	Max Torque value Nm	
			Size	d mm		A	D	D ₁	L	I ₁			
C3	M3-M12	C3-391.60-01080A	2	19	7,5-7,5	80	36	50	99	40,5	-	35	0,35
	M8-M20	C4-391.60-02110A	3	31	12,5-12,5	110	53	63	136	64,5	-	110	1,3
C4	M3-M12	C5-391.60-01080A	2	19	7,5-7,5	80	36	50	110	40,5	-	35	0,9
	M8-M20	C5-391.60-02115A	3	31	12,5-12,5	115	53	63	145	64,5	-	110	1,62
C5	M3-M12	C6-391.60-01090A	2	19	7,5-7,5	90	36	50	128	40,5	-	35	1,4
	M8-M20	C6-391.60-02120A	3	31	12,5-12,5	120	53	63	158	64,5	-	110	2,3
	M14-M33	C6-391.60-03170A	4	48	20,0-20,0	170	78	-	208	-	-	500	3,86
C6	M3-M12	C8-391.60-01085A	2	19	7,5-7,5	85	36	50	134	40,5	-	35	2,21
	M8-M20	C8-391.60-02110A	3	31	12,5-12,5	110	53	63	158	64,5	-	110	2,7
	M14-M33	C8-391.60-03160A	4	48	20,0-20,0	160	78	80	208	129,0	-	500	4,1

Please check availability in current price and stock-list
For quick change tap adapters, please see page(s) 311-312

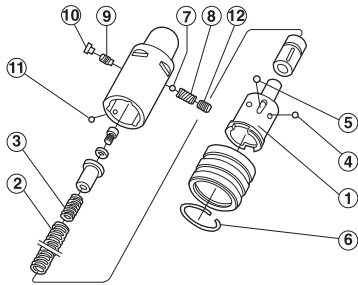

Spare Parts:
2-12 = Complete spare parts set
items

Spare Parts

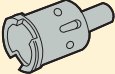
For size	Barrel	Spare parts set
		-
C...-01	5638055-01	5471020-01
C...-02	5638055-02	5471020-02
C...-03	5638055-03	5471020-03

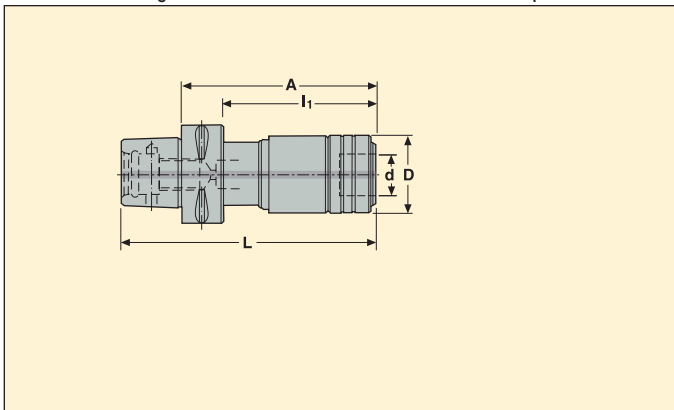

Seco-Capto™ shank	Tapping range	Part No.	For tap adapter		Length compensation mm compression/ extension	Dimensions in mm				Balancing	Max Torque value Nm	
			Size	d mm		A	D	L	I ₁			
C4	M3-M12	C4-391.61-01096	2	19	7,5-7,5	96	39	120	75	-	35	0,69
	C5	M3-M12	C5-391.61-01097	2	19	7,5-7,5	97	39	127	76	-	35
		M8-M20	C5-391.61-02129	3	31	12,5-12,5	129	60	159	-	-	110
C6	M8-M20	C6-391.61-02131	3	31	12,5-12,5	131	60	169	108	-	110	2,4
	M14-M33	C6-391.61-03196	4	48	20,0-20,0	196	86	234	-	-	500	5,7

Please check availability in current price and stock-list
 Max. cutting fluid pressure 50 bar
 For quick change tap adapters, please see page(s) 311-312

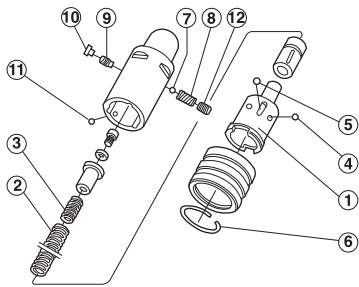

Spare Parts

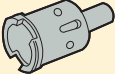
For size	Barrel	Spare parts set
		-
C...-01	5638055-01	5471020-01
C...-02	5638055-02	5471020-02
C...-03	5638055-03	5471020-03

Design 1 (K820)

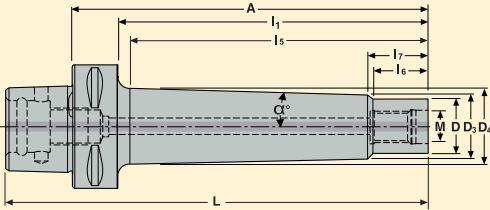

Design 2 (K821)

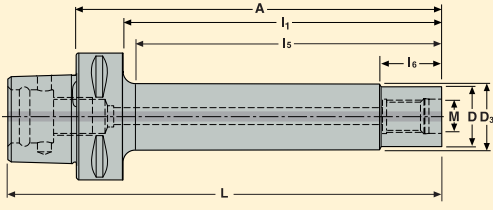

- With dynamic damping, ready to use
- With through coolant

Seco-Capto™ shank	Connecting thread size	Part No.	Dimensions in mm										α°	Design	Max rpm	Balancing	
			A	D	D ₃	D ₄	L	l ₁	l ₅	l ₆	l ₇						
C6	M12	C6-391.K820-12185	185	23,0	30,0	42,1	223	160	155,2	20,0	24,0	2,8	1	10000	2	2,10	
	M16	C6-391.K820-16185	185	30,0	37,0	49,6	223	160	155,2	20,0	24,0	2,8	1	10000	2	2,80	
	M16	C6-391.K820-16235	235	30,0	37,0	54,4	273	210	205,2	20,0	24,0	2,8	1	8000	2	3,60	
	M16	C6-391.K821-16160	160	30,0	30,5	—	198	135	130,0	22,0	—	—	2	10000	2	0,70	

Please check availability in current price and stock-list

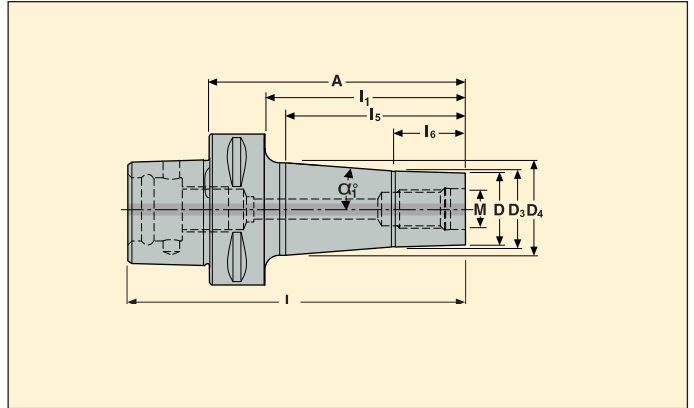

Seco-Capto™ shank	Connecting thread size	Part No.	Dimensions in mm								α_1°	Balancing	
			A	D	D ₃	D ₄	L	I ₁	I ₅	I ₆			
C3	M6	C3-391.5820-06030	30	11,0	11,7	13,5	49	12	10,0	5,0	10,2	1	0,14
	M8	C3-391.5820-08030	30	13,5	15,7	17,5	49	12	10,0	5,0	10,2	1	0,14
	M10	C3-391.5820-10030	30	18,5	19,7	22,0	49	12	10,0	5,0	13,2	1	0,15
	M12	C3-391.5820-12035	35	23,0	24,7	28,0	54	17	15,0	10,0	18,3	1	0,18
	M16	C3-391.5820-16040	40	30,0	31,7	32,0	59	–	–	10,0	0,9	1	0,23
C4	M6	C4-391.5820-06030	30	11,0	11,7	11,7	54	7	5,0	5,0	–	1	0,29
	M8	C4-391.5820-08030	30	13,5	15,7	15,7	54	7	5,0	5,0	–	1	0,26
	M10	C4-391.5820-10035	35	18,5	19,7	22,0	59	12	10,0	5,0	13,0	1	0,28
	M12	C4-391.5820-12040	40	23,0	24,7	28,0	64	17	15,0	10,0	18,3	1	0,33
	M16	C4-391.5820-16045	45	30,0	31,7	35,5	69	22	21,0	10,0	10,8	1	0,38
C5	M6	C5-391.5820-06050	50	11,0	11,7	14,5	80	27	25,0	10,0	5,3	1	0,49
	M8	C5-391.5820-08050	50	13,5	15,7	18,5	80	27	25,0	10,0	5,3	1	0,47
	M10	C5-391.5820-10050	50	18,5	19,7	23,0	80	27	25,0	10,0	6,3	1	0,52
	M12	C5-391.5820-12050	50	23,0	24,7	28,5	80	27	25,0	10,0	7,2	1	0,56
	M16	C5-391.5820-16075	75	30,0	31,7	37,0	105	52	50,0	20,0	5,0	1	0,75
C6	M6	C6-391.5820-06050	50	11,0	11,7	14,0	88	25	20,0	10,0	6,6	1	0,84
	M8	C6-391.5820-08075	75	13,5	15,7	20,0	113	50	45,0	15,0	4,1	1	0,89
	M10	C6-391.5820-10075	75	18,5	19,7	24,0	113	50	45,0	15,0	4,1	1	0,93
	M12	C6-391.5820-12050	50	23,0	24,7	28,0	88	25	20,0	10,0	9,4	1	0,85
	M12	C6-391.5820-12075	75	23,0	24,7	29,5	113	50	45,0	20,0	5,5	1	0,99
	M16	C6-391.5820-16050	50	30,0	31,7	35,5	88	25	20,0	10,0	10,8	1	0,90
	M16	C6-391.5820-16075	75	30,0	31,7	37,0	113	50	45,0	20,0	6,1	1	1,09
C8	M12	C8-391.5820-12085	85	23,0	24,7	35,0	133	52	50,0	20,0	9,7	1	2,04
	M16	C8-391.5820-16085	85	30,0	31,7	42,5	133	52	50,0	20,0	10,2	1	2,16

Please check availability in current price and stock-list

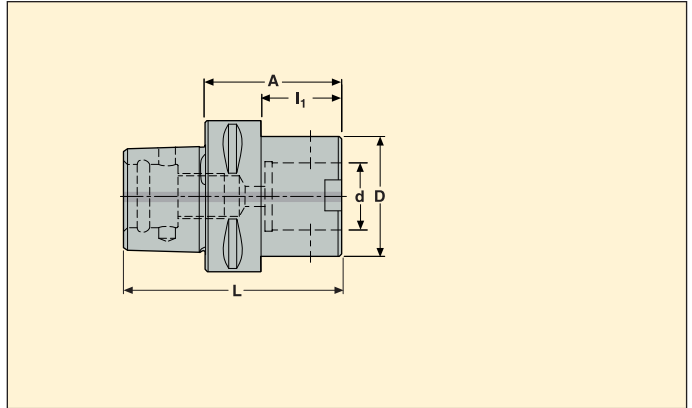

Seco-Capto™ shank	Graflex bore		Part No.	Dimensions in mm				Balancing	
	Size	d mm		A	D	L	I ₁		
C3	G0	8	C3-391.0401-08025	25	16	44	7	1	0,14
	G1	11	C3-391.0401-11025	25	20	44	7	1	0,14
	G2	14	C3-391.0401-14025	25	25	44	7	1	0,15
	G3	18	C3-391.0401-18030	30	32	49	–	1	0,16
C4	G3	18	C4-391.0401-18035	35	32	59	12	1	0,31
	G4	22	C4-391.0401-22035	35	40	59	–	1	0,31
C5	G2	14	C5-391.0401-14030	30	25	60	7	1	0,47
	G3	18	C5-391.0401-18035	35	32	65	12	1	0,47
	G4	22	C5-391.0401-22035	35	40	65	12	1	0,51
	G5	28	C5-391.0401-28045	45	50	75	–	1	0,64
C6	G3	18	C6-391.0401-18035	35	32	73	10	1	0,84
	G4	22	C6-391.0401-22040	40	40	78	15	1	0,89
	G5	28	C6-391.0401-28050	50	50	88	25	1	1,04
	G6	36	C6-391.0401-36055	55	63	93	–	1	1,19
C8	G5	28	C8-391.0401-28050	50	50	98	17	1	1,92
	G6	36	C8-391.0401-36055	55	63	103	22	1	2,02
	G7	46	C8-391.0401-46065	65	90	113	35	2	2,71

Please check availability in current price and stock-list



HSK coolant tubes and sealing plugs

Depending on the machine requirements, HSK Form A, -B, -D, or -E holders must be equipped with a coolant tube or a sealing plug.

WARNING :

Using holders without a coolant tube or a plug fitted, when required, could cause unseen machine spindle damage.

EPB holders HSK-A and HSK-E (standard range), and HSK-B and -D (special), are delivered without coolant tube (2) or sealing plug (1).
Coolant tube (2), tube spanner (3) and sealing plug (1) have to be ordered separately, see page(s) 287.

Coolant tubes, made of two parts and including two identical seals, allow a slight angular movement of $\pm 1^\circ$ (standard requirement).

They require a specific design of mounting spanner (there is no standardised design).

Plugs (delivered with a seal) use standard hexagonal locking keys, not available in the catalogue.

Note: DIN 69893 Form C and -F do generally not require a coolant tube or plug.
Through coolant and sealing functions are provided by the locking unit.

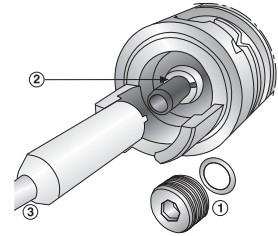

Pull studs

Pull studs (also called retention knobs) are the link between the drawbar of the machine and the holder. The superior material and hardening quality of EPB pull studs is important, as the pulling forces exerted on them can be up to 3000 daN on SA 50 spindles.

Precision machining of the pull studs guarantees precise positioning and safe locking of the holder in the spindle.

Most machines require a standard pull stud design (DIN, ISO, BT, CAT), but some require a specific design.

Standard pull studs and pull studs to convert DIN 69871, BT and CAT holders to DIN 2080 are shown on page(s) 288-292.

Specific pull studs are available on request, please enquire: a sketch or drawing should accompany the enquiry.

Warning: Tighten the small pull studs for SA 30 tapers with moderation, strong tightening may expand the holder's taper back-end.

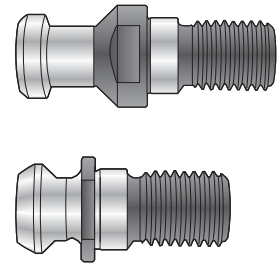

Spare sealing plugs for ADB holders

A number of holders are of the ADB through coolant design.

For B through coolant (flange through coolant), the two originally fitted sealing plugs in the holder's flange have to be removed, and a non through coolant pull stud has to be used so as to seal the back of the holder.

For AD through coolant (central 'draw bar' through coolant), the two sealing plugs in the holder's flange have to be in place, and a through coolant pull stud has to be used.

Spare sealing plugs are shown on page(s) 293.

Sealing paste required for sealing plug mouting is not available from Seco-EPB: we recommend 'LOC-TITE 577 - Thread sealing paste'.

Sealing plug mounting instructions: After cleaning or on a new sealing plug, apply sealing paste onto thread*. Screw sealing plug until its back face is flush with holder's flange back face. Sealing to moderate pressure is obtained instantly; the maximum pressure resistance is reached after 24 hours (100 bar maximum - see also sealing paste's directions for use).

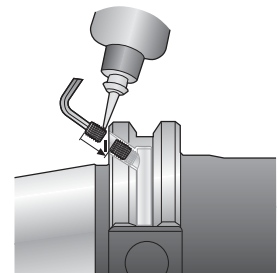

Shrinkfit extensions

Together with the Shrinkfit holders, comes a complete range of Type 5801 slim Shrinkfit extensions with cylindrical shank, tolerance h5. Extensions can be used for extending the overall length of holders, or holding small diameter tools from $\varnothing 3$ mm.



Reduction sleeves for hydraulic chucks

The reduction sleeves for hydraulic chucks act as split collets and allow to grip more shank types and sizes: cylindrical, Weldon, Whistle Notch $\varnothing \leq 25$ mm.

The run-out with the sleeve is maximum $5 \mu\text{m}$ at $3 \times d$ (d being the internal diameter of the sleeve).

Transmittable torque with a reduction sleeve is at least equivalent to chucks without a sleeve.

Note: As the grooves are not all along the sleeves, the coolant is still forced to come through the tool centre (as when using a hydraulic chuck without sleeve)..

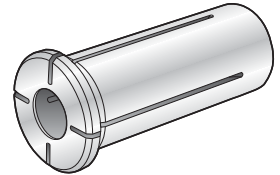

Control gauges for hydraulic chucks

Control gauges are used to check the clamping capability of the hydraulic chuck.

Hydraulic chuck control instructions summary, using a control gauge:

Insert the control gauge into the chuck.

Tighten the clamping screw until you cannot turn the control gauge.

Then it should be possible to complete a minimum of three full turns of the pressurising screw, before completely tightening (2,5 turns for $\varnothing 6$ mm and $\varnothing 8$ mm).

This will confirm that the clamping capability is adequate.

Note: Detailed control instructions are part of the operating instruction sheet delivered with the hydraulic chucks.

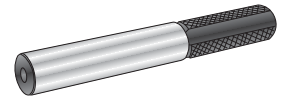

ER HP collets, type 5672 for collet chucks EPB 5672

Collet taper angle: $\alpha = 16^\circ$

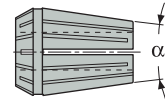

Run-out:

Maximum run-out is $3\ \mu\text{m}$ (up to a maximum of 50mm) when measured at a gauge projection of $3 \times d$ in relation to the external taper of the high precision collet chuck type 5672.

The collet designation 'ER HP' indicates that the collet type 5672 is based on the external design of ISO 15488-B (ER), but equipped with a distinguishing plastic ring in the locking groove to avoid confusing it with a classic ER collet that would not provide the run-out mentioned above.

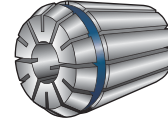

Tool shanks:

Tool shank diameter to be similar to collet's bore (no clamping capacity) and tolerance h10 max.

Range:

A selection of ER HP collets type 5672, not sealed and sealed, in most current diameters is available as standard, as listed on page(s) 297-300.

As shown below, further diameters are available on request, please enquire.

Collet size	Not sealed			Sealed		
	From \varnothing (mm)	To \varnothing (mm)	\varnothing steps (mm)	From \varnothing (mm)	To \varnothing (mm)	\varnothing steps (mm)
ER HP 11	1	7	0,5	3	6	1
ER HP 16*	1	10	0,5	3	10	1
ER HP 25	2	10	0,5	3	16	1
	11	16	1			
ER HP 32	2	20	1	3	20	1

* The collet size ER HP 16 is suitable for both chuck sizes HP 16R and HP 16.

ER collet chuck extensions, with cylindrical shanks

See also information in General guide, page(s) 44.

Extensions are an economical solution to hold smaller tool shanks in existing holders.



ER collets

Norm: ISO 15488-B

Collet taper angle: $\alpha = 16^\circ$.

High flexibility: The clamping range of an ER collet is nominal to -0,5 or -1 mm.

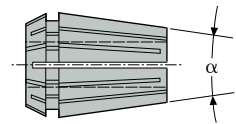

Run-out: Maximum run-out when measured at a gauge projection of $3 \times d$ in relation to the external taper of the ER chuck type 5675 is $10 \mu\text{m}$. When used on 5450 ER extensions the maximum run-out at $3 \times d$ is $15 \mu\text{m}$ ($18 \mu\text{m}$ when using the smallest ER 08).

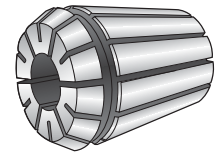

Range: A selection of ER collets in most current diameters is available as standard, as listed on page(s) 302-303.

As shown below, further diameters are available on request, please enquire.

Collet size	From \varnothing (mm)	To \varnothing (mm)	\varnothing steps (mm)	Clamping range (mm)
ER 08	1	5	0,5	-0,5
ER 11	1	7	0,5	-0,5
ER 16	1	2	0,5	-0,5
	2,5	10	0,5	-1
ER 25	1	2	0,5	-0,5
	2,5	16	0,5	-1
ER 32	2	20	0,5	-1
ER 40	3	26	0,5	-1

Sealing rings for ER sealing nuts

ER chucks are delivered as standard with drilled stop end screws for coolant through plain ended tool shanks.

In order to seal other types of shanks, sealing rings are used in conjunction with sealing nuts, see Accessories in ER collet chucks Product pages.

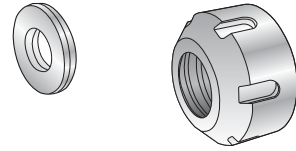

Sealing range of a ring is nominal to -0,5 mm.
Coolant pressure maximum 100 bar.

Sealing ring assembling advice: Insert sealing ring into the nut from the back, until it "clicks" into the nut's front face. The sealing ring's marked face should be oriented inside the nut to avoid erosion of the diameter information marking.
Release by pressure onto the sealing ring's front face.

Range: A selection of ER sealing rings in most current diameters are available as standard, as listed on page(s) 304.

As shown below, further diameters are available on request, please enquire.

Sealing ring size	From \varnothing (mm)	To \varnothing (mm)	\varnothing steps (mm)	Sealing ring (mm)
ER 16	3	10	0,5	-0,5
ER 25	3	16	0,5	-0,5
ER 32	3	20	0,5	-0,5
ER 40*	3	26	0,5	-0,5

* Sealing rings in size ER 40 are only available on request, please enquire.

Note: Sealing rings and sealing nuts in sizes ER 08 and ER 11 are not available.

OZ collets

Norm: DIN 6388

Collet taper angle: $\alpha/2 = 1/10$ (approx. $2^{\circ}52'$).

High flexibility: The clamping range of an OZ collet is nominal to -0.5 mm.

Run-out: Maximum run-out when measured at a gauge projection of $3 \times d$ in relation to the external taper of the OZ chuck type 5873 is $15 \mu\text{m}$.

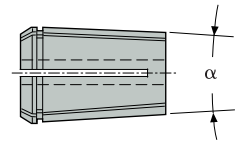

Range: A selection of OZ 32 collets in most current diameters is available as standard, as listed on page(s) 305. As shown below, further diameters are available on request, please enquire.

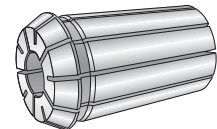

Collet size	From \varnothing (mm)	To \varnothing (mm)	\varnothing steps (mm)	Clamping range (mm)
OZ-B 32	4	32	0,5	-0,5

EPB 5867, ER tapping collets with square drive

Collet taper angle: $\alpha = 16^\circ$

Specific ER collets featuring a driving square to fit the tap's square. These specific ER collets with square are required to secure the tapping process.

Dedicated clamping size on the nominal diameter.

Range: A selection of ER tapping collets in most current diameters and squares is available as standard, as listed on page(s) 308. As shown below, further diameters and squares are available on request, please enquire with diameter and square sizes.

Collet size	From \varnothing (mm)	To \varnothing (mm)	Clamping range
ER 11	2,5	6	0
ER 20	4,0	12	0
ER 25	4,0	16	0
ER 40	12,0	22	0

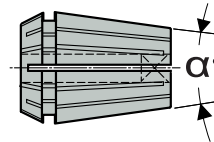

EPB 5867, Sealing rings

The EPB 5867 tapping chucks are delivered with collet clamping nuts allowing the fitting of sealing rings, available as Additional equipment. The rings prevent coolant to flow through the collet's grooves, forcing coolant to flow through the tap's coolant channel. Coolant pressure maximum 150 bar.

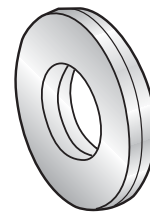

Sealing ring assembling advice: Insert sealing ring into the nut from the back, until it "clicks" into the nut's front face. The sealing ring's marked face should be oriented inside the nut to avoid erosion of the diameter information marking.

Release by pressure onto the sealing ring's front face.

Range: A selection of EPB 5867 sealing rings in most current diameters are available as standard, as listed on page(s) 309.

As shown below, further diameters are available on request, please enquire

Sealing ring size	From \varnothing (mm)	To \varnothing (mm)	\varnothing steps (mm)	Sealing ring (mm)
ER 20	4	12	0,5	-0,5
ER 25	4	16	0,5	-0,5
ER 40	6	22	0,5	-0,5

Assembly advice for ER, ER tapping collets and OZ collets

The collet must always be inserted into the nut, and the nut screwed onto the chuck before introducing the tool into the collet.

The collet is fitted inside the nut by applying slight pressure A, and released by a radial pressure B.

Never lock the nut without a tool in place.

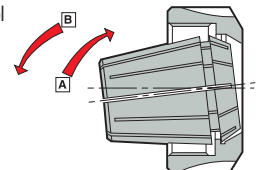

Quick change tapping chucks, with Weldon/Whistle Notch combined back end shank

These quick change tapping chucks with axial compensation have economic advantages as they are not dependent on a specific spindle size. See more information in General guide, page(s) 47.

Quick change tap adapters

Permit quick changing of the tap and adapter.

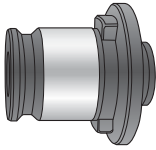

Adapters without torque limiter
Type T5241

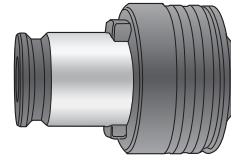

Adapters with torque limiter
Type T5285

The adapter has to be chosen according to the tap shank diameter and its square size. Both dimensions are in relation to norms DIN, ISO, PIPE, which also cover the thread size. Suitable for taps with or without through coolant channel.

The torque of an adapter with a torque limiter, is set according to the thread size, when delivered. Therefore a tap with the same shank diameter and same square size, but with a different pitch (e.g. $\varnothing 6 \times 4,9$ comes in M5 and M6) cannot be substituted.

For adapters without torque limiter this can be done, as only tap shank diameter and square are critical.

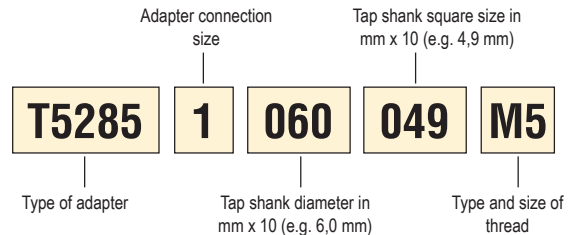

Assembly supports, Tool Boy

This indexable toolholder assembly support provides a safe and efficient tool preparation facility. Easily fixed to a workbench.

Tool Boy assembly supports are made of a base unit and a head. The common base unit accommodates all head types and sizes.

Several holder locking systems are available, depending on the type of taper: fast spring bolt for HSK/ SA40/ Seco-Capto™; screw bolt for SA50; clamping ring for VDI.

A selection of Toolboy for most current tool holder types and sizes is available as standard, as listed in the product page. Further types are available on request, please enquire.

Horizontal orientation to right or left, e.g. for tool and insert assembly.



Vertical orientation up or downwards, e.g. for boring head setting or pull stud mounting.



HSK locking units, TF

TF units enable spindles with HSK interface to be adapted to take HSK-C and HSK-A holders. For access to the locking mechanism, HSK-A holders must have the radial access hole in the taper. Units also enable the release of the holder from the spindle (HSK is self-locking).

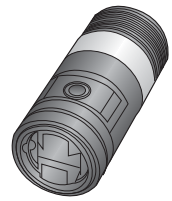

Operating principle

Locking: the side access locking screw activates two gripping jaws, which exert axial and radial locking forces on to the holder's internal pulling taper.

This locks the holder into the spindle and pushes the coolant seal onto the internal face. (Fig. 1 and 2).

Releasing: by turning the screw in the opposite direction the jaws are removed from the pulling taper and the ejector pushes on the holder's internal face to release it from the spindle (Fig. 3).

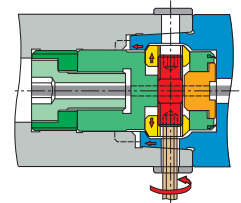

Fig. 1

Main features:

The two locking jaws are self orientating in order to achieve four point locking.

The locking principle guarantees the required HSK locking pressures.

Sealing is designed to withstand high pressure coolant flow.

Symmetrical acting ejector, no risk of holder sticking.

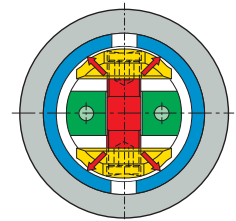

Fig. 2

Unit fitting:

Simple and inexpensive spindle machining operations for fitting the unit, based on a thread and a centering bore. See page(s) 318, showing also indexing pins as Accessories.

The unit is fitted by screwing down to a dead stop. A slip clutch allows alignment of the unit clamping screw with the access holes in the spindle.

After alignment, secure the slip clutch by tightening the screw located at the bottom of the two coolant holes.

For installing and removing the units use the dedicated spanners available in Accessories.

For application details, refer to the instruction sheet supplied with the unit.

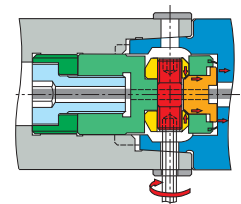

Fig. 3

HSK locking flange mounts, TF

TF flange mounts allow spindle front faces to be easily equipped with a complete HSK connection (HSK interface and locking). The flange mounts have a precise HSK taper/face, drivers for HSK-A and HSK-C holders, and include a TF locking unit, already fitted.

Three flange types are available:

- Type BR1: with radial and angular adjustment.
- Type BR2: short, with radial adjustment.
- Type BR3: short and slim, with radial adjustment.

Features:

Protecting ring to seal the mount's radial holes for TF unit access.
Simple and inexpensive spindle machining operations for fitting the flange mount.
See machining advice in Product pages.

Flanges are delivered with all components included, also shown as spare parts.
Spanners to release the TF units are available in Accessories, see page(s) 314.
Indexing pins available as Accessories are listed on page(s) 318.

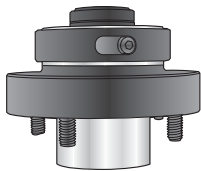

BR1

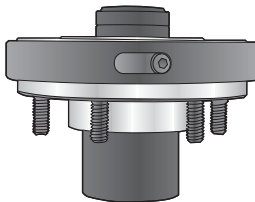

BR2

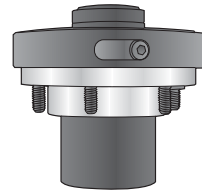

BR3

HSK coolant tubes, tube spanners and sealing plugs

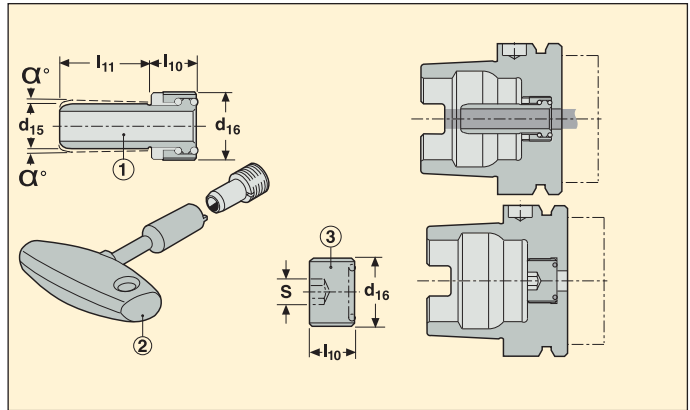

Description	For holders HSK Form A and E	Part No.	d ₁₆	Dimensions in mm				α°
				d ₁₅	l ₁₀	l ₁₁	S	
Coolant tubes (1)	32	20E9301	M10x1	6	6	20	-	1
	40	20E9302	M12x1	8	8	21.5	-	1
	50	20E9303	M16x1	10	10	23	-	1
	63	20E9304	M18x1	12	12	24.5	-	1
	100	20E9306	M24x1,5	16	16	28	-	1
Coolant tube spanners (2)	32	03E9301	-	-	-	-	-	-
	40	03E9302	-	-	-	-	-	-
	50	03E9303	-	-	-	-	-	-
	63	03E9304	-	-	-	-	-	-
	100	03E9306	-	-	-	-	-	-
Sealing plugs (3)	32	02E9301	M10x1	-	6	-	3	-
	40	02E9302	M12x1	-	8	-	4	-
	50	02E9303	M16x1	-	10	-	5	-
	63	02E9304	M18x1	-	12	-	6	-
	100	02E9306	M24x1,5	-	16	-	10	-

Please check availability in current price and stock-list

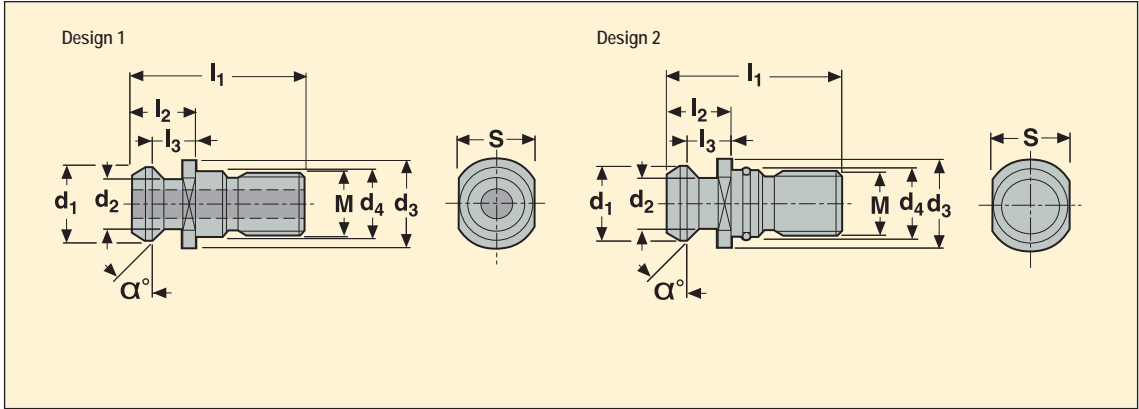

For taper	Part No.	M	Dimensions in mm								Coolant channel		α°	Design	
			d ₁	d ₂	d ₃	d ₄	l ₁	l ₂	l ₃	S	Yes	No			
40	E954421628	M16	18,95	12,95	22,5	17	44,5	16,40	11,15	18	■		45	1	0,06
	E954421628B	M16	18,95	12,95	22,5	17	44,5	16,40	11,15	18		■	45	2	0,07
50	E954402440	M24	29,10	19,60	37,0	25	65,5	25,55	17,95	30	■		45	1	0,18
	E954402440B	M24	29,10	19,60	37,0	25	65,5	25,55	17,95	30		■	45	2	0,23

Please check availability in current price and stock-list

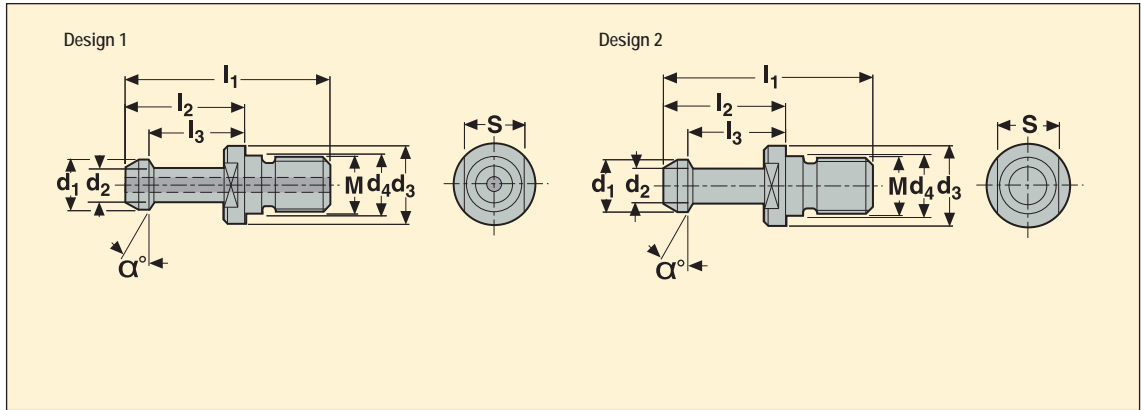

For taper	Part No.	M	Dimensions in mm								Coolant channel		α°	*	Design	
			d ₁	d ₂	d ₃	d ₄	l ₁	l ₂	l ₃	S	Yes	No				
30	E950941220P	M12	11	7	16,5	12,5	43	23	18	13	■		45		1	0,03
	E950951220P	M12	11	7	16,5	12,5	43	23	18	13	■		30		1	0,03
	E950941220	M12	11	7	16,5	12,5	43	23	18	13		■	45		2	0,03
	E950951220	M12	11	7	16,5	12,5	43	23	18	13		■	30		2	0,03
40	E954001625P	M16	15	10	23,0	17,0	60	35	28	19	■		45		1	0,08
	E955201625P	M16	15	10	23,0	17,0	60	35	28	19	■		30		1	0,07
	E950911625P	M16	15	10	23,0	17,0	60	35	28	19	■		0		1	0,07
	E954001625	M16	15	10	23,0	17,0	60	35	28	19		■	45		2	0,08
	E955201625	M16	15	10	23,0	17,0	60	35	28	19		■	30		2	0,08
	E950911625	M16	15	10	23,0	17,0	60	35	28	19		■	0		2	0,08
	E955711625	M16	15	10	23,0	17,0	50	25	18	19		■	0		2	0,07
50	E955502440P	M24	23	17	38,0	25,0	85	45	35	30	■		45		1	0,24
	E9599212440P	M24	23	17	38,0	25,0	85	45	35	30	■		30		1	0,24
	E955702440P	M24	24	18	36,0	25,0	71	31	23	30	■		0		1	0,21
	E956802440P	M24	23	17	38,0	25,0	85	45	35	30	■		0		1	0,24
	E955502440	M24	23	17	38,0	25,0	85	45	35	30		■	45		2	0,28
	E9599212440	M24	23	17	38,0	25,0	85	45	35	30		■	30		2	0,28
	E956802440	M24	23	17	38,0	25,0	85	45	35	30		■	0		2	0,28

Please check availability in current price and stock-list

Pull studs for DIN/ CAT Metric combined holders

ANSI B5-50 with metric thread

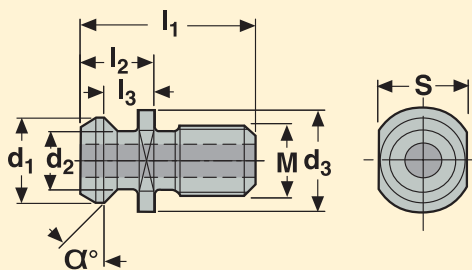

For taper	Part No.	M	Dimensions in mm							Coolant channel		α°	
			\$d_1\$	\$d_2\$	\$d_3\$	\$l_1\$	\$l_2\$	\$l_3\$	\$S\$	Yes	No		
40	E953961622	M16	18,95	12,95	22,5	38	16,40	11,0	18	<input checked="" type="checkbox"/>	<input type="checkbox"/>	45	0,05
50	E953982433	M24	29,10	19,60	37,0	59	25,55	17,8	30	<input checked="" type="checkbox"/>	<input type="checkbox"/>	45	0,16

Please check availability in current price and stock-list

Pull studs DIN 2080 compatible

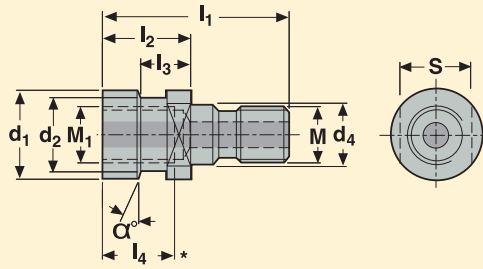

For taper	Holders	M	M ₁	Part No.	Dimensions in mm								Coolant channel		α°	
					d ₁	d ₂	d ₄	l ₁	l ₂	l ₃	l ₄	S	Yes	No		
40	DIN 69871 CAT/ DIN compatible	M16	M16	E9599161628	25,3	21,1	17	53,1	25,1	14,2	19	18	■		15	0,08
	BT	M16	M16	E9599791628	25,3	21,1	17	56,0	27,9	17,1	19	19	■		15	0,08
50	DIN 69871 CAT/ DIN Combined BT	M24	M24	E9599322440	39,6	32,0	25	65,1	25,1	13,3	18	30	■		0	0,22

Please check availability in current price and stock-list
 * Limited length, may require pulling system adaptation

Sealing plugs for DIN ADB and BT ADB tapers (Spare parts)

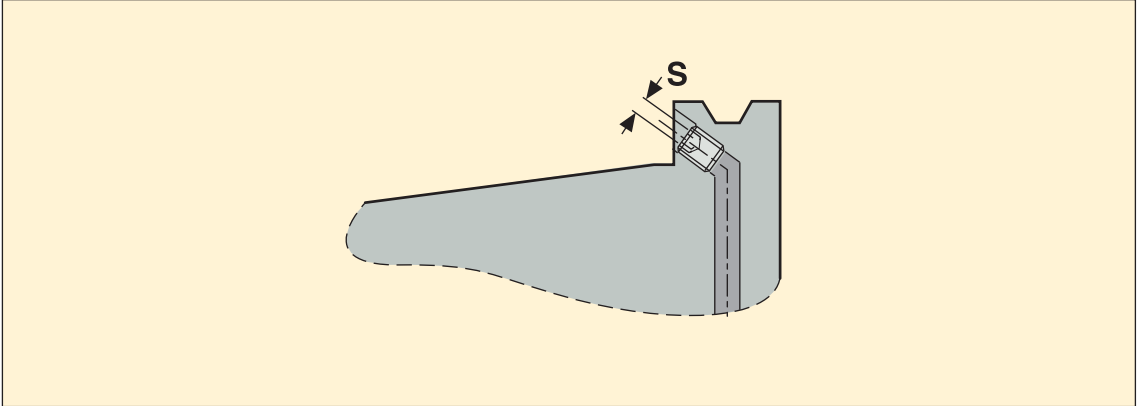

For holder	Part No.	S mm
DIN40 ADB/ BT40 ADB	950A0406	2
DIN50 ADB/ BT50 ADB	950A0606	3

Please check availability in current price and stock-list
 Plug mounting and sealing instructions, see page(s) 278

EPB 5801 - Shrinkfit holders, with cylindrical shank



- Run-out 3 μm at 3xd (direct run-out 3 μm) maximum
- Cylindrical shank d_1 with tolerance h5, compatible for Shrinkfit

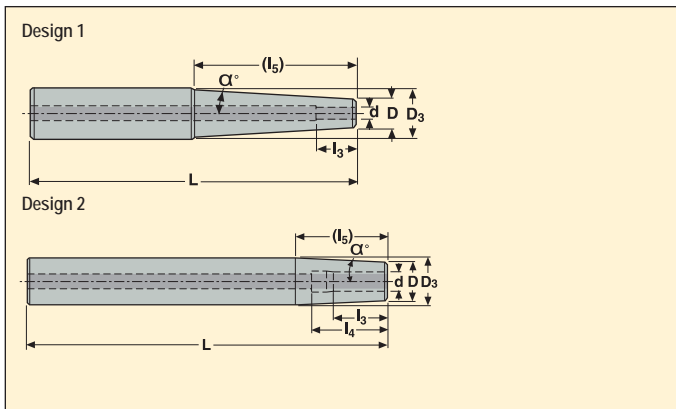

Shank mm	d mm	Part No.	Dimensions in mm							Design	α°	Balancing	KG
			D	D ₃	L	l ₃	l ₄	l ₅					
16	3	BD01658010352	9	14,5	100	13	-	51	1	3	2	0,11	
	3	BD016580103102	9	16,0	150	13	-	66	2	3	2	0,18	
	4	BD01658010452	10	15,5	100	15	-	51	1	3	2	0,12	
	4	BD016580104102	10	16,0	150	15	-	57	2	3	2	0,19	
	5	BD01658010552	11	16,0	100	18	-	47	2	3	2	0,12	
	6	BD01658010652	12	16,0	100	26	40	38	2	3	2	0,13	
	6	BD016580106102	12	16,0	150	26	40	38	2	3	2	0,20	
20	8	BD02058010850	16	20,0	100	30	44	38	2	3	2	0,20	
	8	BD020580108100	16	20,0	150	30	44	38	2	3	2	0,32	
	10	BD02058011050	18	20,0	100	32	45	19	2	3	2	0,21	
	10	BD020580110100	18	20,0	150	32	45	19	2	3	2	0,31	
	12	BD02058011250	20	20,0	100	34	46	-	2	3	2	0,19	
		12	BD020580112100	20	20,0	150	34	46	-	2	3	2	0,30

Please check availability in current price and stock-list

EPB 5832 - Reduction sleeves for hydraulic chucks



- Run-out 5 μm maximum at 3xd when assembled
- Nominal clamping diameter only (no clamping range)
- Tool shank tolerance h6 maximum

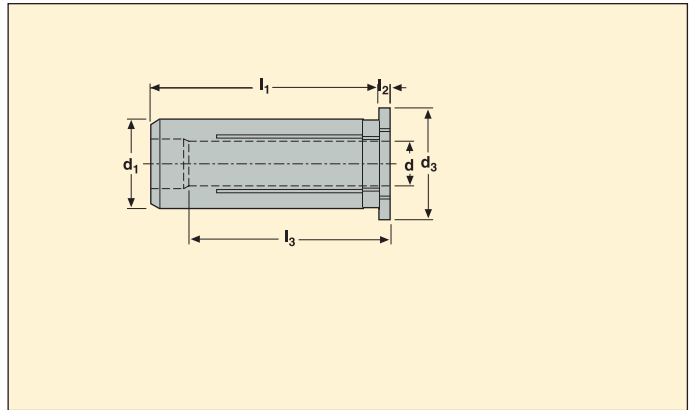

d ₁ mm	d mm	Part No.	Dimensions in mm			
			d ₃	l ₁	l ₂	l ₃
12	3	05F58321203	16	40	4	29
	4	05F58321204	16	40	4	29
	5	05F58321205	16	40	4	29
	6	05F58321206	16	40	4	36
	8	05F58321208	16	40	4	37
	10	05F58321210	16	40	4	40
20	3	05F58322003	25	50	4	28
	4	05F58322004	25	50	4	28
	5	05F58322005	25	50	4	28
	6	05F58322006	25	50	4	36
	8	05F58322008	25	50	4	37
	10	05F58322010	25	50	4	40
	12	05F58322012	25	50	4	45
	14	05F58322014	25	50	4	45
	16	05F58322016	25	50	4	48
32	6	05F58323206	36	60	4	36
	8	05F58323208	36	60	4	36
	10	05F58323210	36	60	4	40
	12	05F58323212	36	60	4	45
	14	05F58323214	36	60	4	46
	16	05F58323216	36	60	4	48
	18	05F58323218	36	60	4	49
	20	05F58323220	36	60	4	50
	25	05F58323225	36	60	4	56

Please check availability in current price and stock-list

EPB 5832 - Control gauges for hydraulic chucks

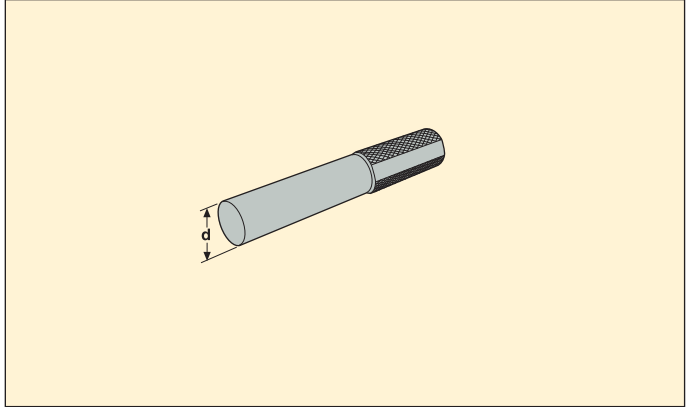

- Control gauges to check chuck's clamping capability, see instructions in Guide pages

Description	Part No.	d mm	
Control gauges	CA583206	6	
	CA583208	8	
	CA583210	10	
	CA583212	12	
	CA583214	14	
	CA583216	16	
	CA583218	18	
	CA583220	20	
	CA583225	25	
	CA583232	32	

Please check availability in current price and stock-list

EPB 5672 – ER HP collets, not sealed

ISO 15488-B

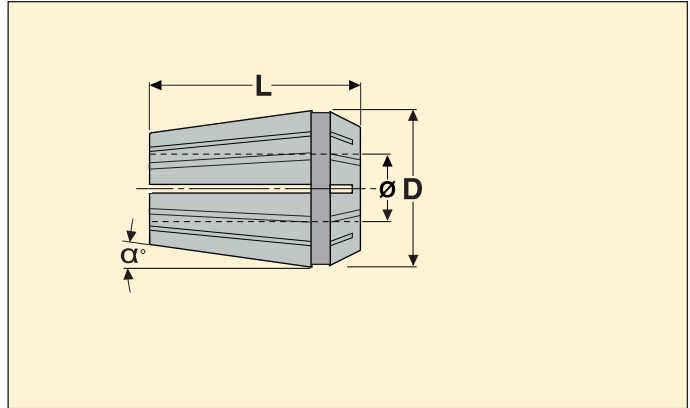

- Run-out 3 µm maximum at 3xd when assembled on a HP collet chuck, EPB 5672
- Nominal clamping diameter only (no clamping range)
- Tool shank tolerance h10 maximum

For chuck		Part No.	Dimensions in mm			α°
Capacity Ø mm	Size		Collet bore	D	L	
1-7	HP 11	56721101	1,0	11,5	18	8
	HP 11	567211015	1,5	11,5	18	8
	HP 11	56721102	2,0	11,5	18	8
	HP 11	567211025	2,5	11,5	18	8
	HP 11	56721103	3,0	11,5	18	8
	HP 11	567211035	3,5	11,5	18	8
	HP 11	56721104	4,0	11,5	18	8
	HP 11	567211045	4,5	11,5	18	8
	HP 11	56721105	5,0	11,5	18	8
	HP 11	567211055	5,5	11,5	18	8
	HP 11	56721106	6,0	11,5	18	8
	HP 11	567211065	6,5	11,5	18	8
	HP 11	56721107	7,0	11,5	18	8
1-10	HP 16	56721601	1,0	17,0	27,0	8
	HP 16	567216015	1,5	17,0	27,0	8
	HP 16	56721602	2,0	17,0	27,0	8
	HP 16	567216025	2,5	17,0	27,0	8
	HP 16	56721603	3,0	17,0	27,0	8
	HP 16	567216035	3,5	17,0	27,0	8
	HP 16	56721604	4,0	17,0	27,0	8
	HP 16	567216045	4,5	17,0	27,0	8
	HP 16	56721605	5,0	17,0	27,0	8
	HP 16	567216055	5,5	17,0	27,0	8
	HP 16	56721606	6,0	17,0	27,0	8
	HP 16	567216065	6,5	17,0	27,0	8
	HP 16	56721607	7,0	17,0	27,0	8
	HP 16	567216075	7,5	17,0	27,0	8
	HP 16	56721608	8,0	17,0	27,0	8
	HP 16	567216085	8,5	17,0	27,0	8
	HP 16	56721609	9,0	17,0	27,0	8
	HP 16	567216095	9,5	17,0	27,0	8
	HP 16	56721610	10,0	17,0	27,0	8

Please check availability in current price and stock-list

Additional equipment

EPB 5672 – ER HP collets, not sealed

ISO 15488-B

For chuck		Part No.	Dimensions in mm			α°
Capacity ∅ mm	Size		Collet bore	D	L	
2-16	HP 25	56722502	2,0	26,0	34,0	8
	HP 25	567225025	2,5	26,0	34,0	8
	HP 25	56722503	3,0	26,0	34,0	8
	HP 25	567225035	3,5	26,0	34,0	8
	HP 25	56722504	4,0	26,0	34,0	8
	HP 25	567225045	4,5	26,0	34,0	8
	HP 25	56722505	5,0	26,0	34,0	8
	HP 25	567225055	5,5	26,0	34,0	8
	HP 25	56722506	6,0	26,0	34,0	8
	HP 25	567225065	6,5	26,0	34,0	8
	HP 25	56722507	7,0	26,0	34,0	8
	HP 25	567225075	7,5	26,0	34,0	8
	HP 25	56722508	8,0	26,0	34,0	8
	HP 25	567225085	8,5	26,0	34,0	8
	HP 25	56722509	9,0	26,0	34,0	8
	HP 25	567225095	9,5	26,0	34,0	8
HP 25	56722510	10,0	26,0	34,0	8	
HP 25	56722511	11,0	26,0	34,0	8	
HP 25	56722512	12,0	26,0	34,0	8	
HP 25	56722513	13,0	26,0	34,0	8	
HP 25	56722514	14,0	26,0	34,0	8	
HP 25	56722515	15,0	26,0	34,0	8	
HP 25	56722516	16,0	26,0	34,0	8	
2-20	HP 32	56723202	2,0	33,0	40,0	8
	HP 32	56723203	3,0	33,0	40,0	8
	HP 32	56723204	4,0	33,0	40,0	8
	HP 32	56723205	5,0	33,0	40,0	8
	HP 32	56723206	6,0	33,0	40,0	8
	HP 32	56723207	7,0	33,0	40,0	8
	HP 32	56723208	8,0	33,0	40,0	8
	HP 32	56723209	9,0	33,0	40,0	8
	HP 32	56723210	10,0	33,0	40,0	8
	HP 32	56723211	11,0	33,0	40,0	8
	HP 32	56723212	12,0	33,0	40,0	8
	HP 32	56723213	13,0	33,0	40,0	8
	HP 32	56723214	14,0	33,0	40,0	8
	HP 32	56723215	15,0	33,0	40,0	8
	HP 32	56723216	16,0	33,0	40,0	8
	HP 32	56723217	17,0	33,0	40,0	8
HP 32	56723218	18,0	33,0	40,0	8	
HP 32	56723219	19,0	33,0	40,0	8	
HP 32	56723220	20,0	33,0	40,0	8	

Please check availability in current price and stock-list

EPB 5672 – ER HP collets, sealed

ISO 15488-A



- Run-out 3 μm maximum at 3xd when assembled on a HP collet chuck, EPB 5672
- Nominal clamping diameter only (no clamping range)
- Tool shank tolerance h10 maximum

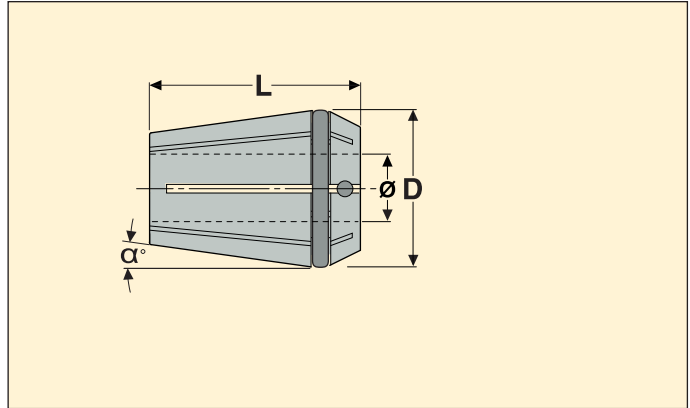

For chuck		Part No.	Dimensions in mm			α°	
Capacity Ø mm	Size		Collet bore	D	L		
3-6	HP 11	5672S1103	3,0	11,5	18,0	8	
	HP 11	5672S1104	4,0	11,5	18,0	8	
	HP 11	5672S1105	5,0	11,5	18,0	8	
	HP 11	5672S1106	6,0	11,5	18,0	8	
3-10	HP 16	5672S1603	3,0	17,0	27,0	8	
	HP 16	5672S1604	4,0	17,0	27,0	8	
	HP 16	5672S1605	5,0	17,0	27,0	8	
	HP 16	5672S1606	6,0	17,0	27,0	8	
	HP 16	5672S1607	7,0	17,0	27,0	8	
	HP 16	5672S1608	8,0	17,0	27,0	8	
	HP 16	5672S1609	9,0	17,0	27,0	8	
	HP 16	5672S1610	10,0	17,0	27,0	8	
3-16	HP 25	5672S2503	3,0	26,0	34,0	8	
	HP 25	5672S2504	4,0	26,0	34,0	8	
	HP 25	5672S2505	5,0	26,0	34,0	8	
	HP 25	5672S2506	6,0	26,0	34,0	8	
	HP 25	5672S2507	7,0	26,0	34,0	8	
	HP 25	5672S2508	8,0	26,0	34,0	8	
	HP 25	5672S2509	9,0	26,0	34,0	8	
	HP 25	5672S2510	10,0	26,0	34,0	8	
	HP 25	5672S2511	11,0	26,0	34,0	8	
	HP 25	5672S2512	12,0	26,0	34,0	8	
	HP 25	5672S2513	13,0	26,0	34,0	8	
	HP 25	5672S2514	14,0	26,0	34,0	8	
	HP 25	5672S2515	15,0	26,0	34,0	8	
	HP 25	5672S2516	16,0	26,0	34,0	8	

Please check availability in current price and stock-list

EPB 5672 – ER HP collets, sealed

ISO 15488-A

For chuck		Part No.	Dimensions in mm			α°
Capacity ∅ mm	Size		Collet bore	D	L	
3-20	HP 32	5672S3203	3,0	33,0	40,0	8
	HP 32	5672S3204	4,0	33,0	40,0	8
	HP 32	5672S3205	5,0	33,0	40,0	8
	HP 32	5672S3206	6,0	33,0	40,0	8
	HP 32	5672S3207	7,0	33,0	40,0	8
	HP 32	5672S3208	8,0	33,0	40,0	8
	HP 32	5672S3209	9,0	33,0	40,0	8
	HP 32	5672S3210	10,0	33,0	40,0	8
	HP 32	5672S3211	11,0	33,0	40,0	8
	HP 32	5672S3212	12,0	33,0	40,0	8
	HP 32	5672S3213	13,0	33,0	40,0	8
	HP 32	5672S3214	14,0	33,0	40,0	8
	HP 32	5672S3215	15,0	33,0	40,0	8
	HP 32	5672S3216	16,0	33,0	40,0	8
	HP 32	5672S3217	17,0	33,0	40,0	8
	HP 32	5672S3218	18,0	33,0	40,0	8
	HP 32	5672S3219	19,0	33,0	40,0	8
	HP 32	5672S3220	20,0	33,0	40,0	8

Please check availability in current price and stock-list

EPB 5450 - ER collet chucks, with cylindrical shank

ISO 15488



- Run-out 15 µm maximum at 3xd (18 µm when using the smallest ER 08)
- Cylindrical shank d₁ with tolerance h5, compatible for Shrinkfit

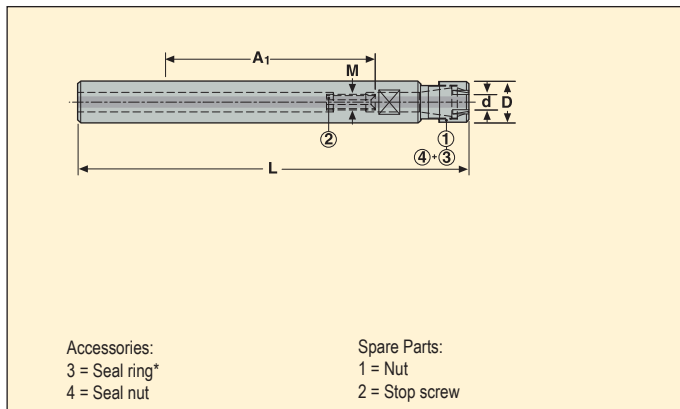

Shank mm	Capacity d mm	Part No.	Size	Dimensions in mm				**	Balancing	KG
				D	L	M	A ₁ min-max			
12	0,5-5	54501208R	ER 08	12	150	M5	65-86	**	2	0,10
16	0,5-7	54501612R	ER 11	16	150	M6	62-83		2	0,18
16	0,5-10	54501616R	ER 16	22	160	M8	72-82		2	0,18
25	1-16	54502525R	ER 25	35	160	M18x1,5	36-61		2	0,39
32	2-20	54503232	ER 32	50	160	M22x1,5	33-53		2	0,75

For ER collets, see page(s) 302-303

** Stop end screw not drilled

Accessories*

For size	Seal nut	Spanner
ER 08	–	03B545008
ER 11	–	03B545011
ER 16	08B587516MC	03B545016
ER 25	08B587525MC	03B545025
ER 32	08B587532IC	03B587532

Spare Parts**

For size	Nut	Stop screw
ER 08	08B587508M	19B58705
ER 11	08B587511M	19B58706
ER 16	08B587516M	19B58708R10
ER 25	08B587525M	19B58718
ER 32	08B587532X	19B58722

Please check availability in current price and stock-list

** Stop screw 19B58705 not drilled

* For ER sealing rings Part No., see page(s) 304

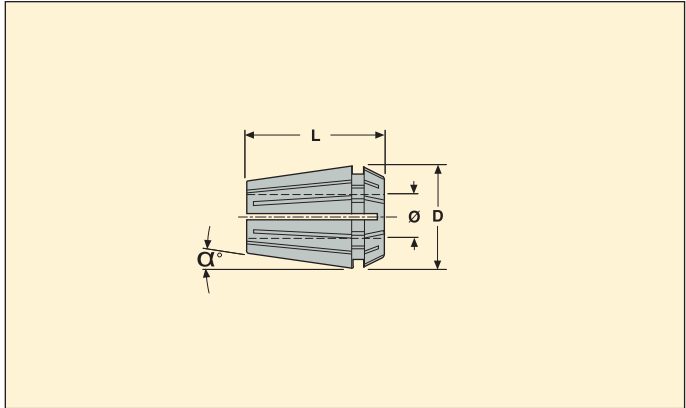

- Run-out 10 µm maximum at 3xd when assembled on a ER chuck type 5675
- Clamping range -0,5 or -1 mm

For chuck		Part No.	Capacity d mm	Dimensions in mm			α°
Capacity Ø mm	Size			Collet bore	D	L	
0,5-5	ER 08	58800801	0,5-1	1,0	8,5	13,5	8
	ER 08	588008015	1-1,5	1,5	8,5	13,5	8
	ER 08	58800802	1,5-2	2,0	8,5	13,5	8
	ER 08	588008025	2-2,5	2,5	8,5	13,5	8
	ER 08	58800803	2,5-3	3,0	8,5	13,5	8
	ER 08	588008035	3-3,5	3,5	8,5	13,5	8
	ER 08	58800804	3,5-4	4,0	8,5	13,5	8
	ER 08	588008045	4-4,5	4,5	8,5	13,5	8
0,5-7	ER 08	58800805	4,5-5	5,0	8,5	13,5	8
	ER 11	58801101	0,5-1	1,0	11,5	18,0	8
	ER 11	588011015	1-1,5	1,5	11,5	18,0	8
	ER 11	58801102	1,5-2	2,0	11,5	18,0	8
	ER 11	588011025	2-2,5	2,5	11,5	18,0	8
	ER 11	58801103	2,5-3	3,0	11,5	18,0	8
	ER 11	588011035	3-3,5	3,5	11,5	18,0	8
	ER 11	58801104	3,5-4	4,0	11,5	18,0	8
	ER 11	588011045	4-4,5	4,5	11,5	18,0	8
	ER 11	58801105	4,5-5	5,0	11,5	18,0	8
	ER 11	588011055	5-5,5	5,5	11,5	18,0	8
0,5-10	ER 11	58801106	5,5-6	6,0	11,5	18,0	8
	ER 11	588011065	6-6,5	6,5	11,5	18,0	8
	ER 11	58801107	6,5-7	7,0	11,5	18,0	8
	ER 16	58801601	0,5-1	1,0	17,0	27,0	8
	ER 16	58801602	1,5-2	2,0	17,0	27,0	8
	ER 16	58801603	2-3	3,0	17,0	27,0	8
	ER 16	58801604	3-4	4,0	17,0	27,0	8
	ER 16	58801605	4-5	5,0	17,0	27,0	8
	ER 16	58801606	5-6	6,0	17,0	27,0	8
	ER 16	58801607	6-7	7,0	17,0	27,0	8
	ER 16	58801608	7-8	8,0	17,0	27,0	8
ER 16	58801609	8-9	9,0	17,0	27,0	8	
ER 16	58801610	9-10	10,0	17,0	27,0	8	

Please check availability in current price and stock-list

For chuck		Part No.	Capacity d mm	Dimensions in mm			α°
Capacity \varnothing mm	Size			Collet bore	D	L	
1-16	ER 25	58802502	1,5-2	2,0	26,0	34,0	8
	ER 25	58802503	2-3	3,0	26,0	34,0	8
	ER 25	58802504	3-4	4,0	26,0	34,0	8
	ER 25	58802505	4-5	5,0	26,0	34,0	8
	ER 25	58802506	5-6	6,0	26,0	34,0	8
	ER 25	58802507	6-7	7,0	26,0	34,0	8
	ER 25	58802508	7-8	8,0	26,0	34,0	8
	ER 25	58802509	8-9	9,0	26,0	34,0	8
	ER 25	58802510	9-10	10,0	26,0	34,0	8
	ER 25	58802511	10-11	11,0	26,0	34,0	8
	ER 25	58802512	11-12	12,0	26,0	34,0	8
	ER 25	58802513	12-13	13,0	26,0	34,0	8
	ER 25	58802514	13-14	14,0	26,0	34,0	8
	ER 25	58802515	14-15	15,0	26,0	34,0	8
ER 25	58802516	15-16	16,0	26,0	34,0	8	
2-20	ER 32	58803203	2-3	3,0	33,0	40,0	8
	ER 32	58803204	3-4	4,0	33,0	40,0	8
	ER 32	58803205	4-5	5,0	33,0	40,0	8
	ER 32	58803206	5-6	6,0	33,0	40,0	8
	ER 32	58803207	6-7	7,0	33,0	40,0	8
	ER 32	58803208	7-8	8,0	33,0	40,0	8
	ER 32	58803209	8-9	9,0	33,0	40,0	8
	ER 32	58803210	9-10	10,0	33,0	40,0	8
	ER 32	58803211	10-11	11,0	33,0	40,0	8
	ER 32	58803212	11-12	12,0	33,0	40,0	8
	ER 32	58803213	12-13	13,0	33,0	40,0	8
	ER 32	58803214	13-14	14,0	33,0	40,0	8
	ER 32	58803215	14-15	15,0	33,0	40,0	8
	ER 32	58803216	15-16	16,0	33,0	40,0	8
	ER 32	58803217	16-17	17,0	33,0	40,0	8
	ER 32	58803218	17-18	18,0	33,0	40,0	8
ER 32	58803219	18-19	19,0	33,0	40,0	8	
ER 32	58803220	19-20	20,0	33,0	40,0	8	
3-26	ER 40	58804004	3-4	4,0	41,0	46,0	8
	ER 40	58804005	4-5	5,0	41,0	46,0	8
	ER 40	58804006	5-6	6,0	41,0	46,0	8
	ER 40	58804007	6-7	7,0	41,0	46,0	8
	ER 40	58804008	7-8	8,0	41,0	46,0	8
	ER 40	58804009	8-9	9,0	41,0	46,0	8
	ER 40	58804010	9-10	10,0	41,0	46,0	8
	ER 40	58804011	10-11	11,0	41,0	46,0	8
	ER 40	58804012	11-12	12,0	41,0	46,0	8
	ER 40	58804013	12-13	13,0	41,0	46,0	8
	ER 40	58804014	13-14	14,0	41,0	46,0	8
	ER 40	58804015	14-15	15,0	41,0	46,0	8
	ER 40	58804016	15-16	16,0	41,0	46,0	8
	ER 40	58804017	16-17	17,0	41,0	46,0	8
	ER 40	58804018	17-18	18,0	41,0	46,0	8
	ER 40	58804019	18-19	19,0	41,0	46,0	8
	ER 40	58804020	19-20	20,0	41,0	46,0	8
	ER 40	58804021	20-21	21,0	41,0	46,0	8
	ER 40	58804022	21-22	22,0	41,0	46,0	8
	ER 40	58804023	22-23	23,0	41,0	46,0	8
ER 40	58804024	23-24	24,0	41,0	46,0	8	
ER 40	58804025	24-25	25,0	41,0	46,0	8	
ER 40	58804026	25-26	26,0	41,0	46,0	8	

Please check availability in current price and stock-list

EPB 5875 - ER sealing rings

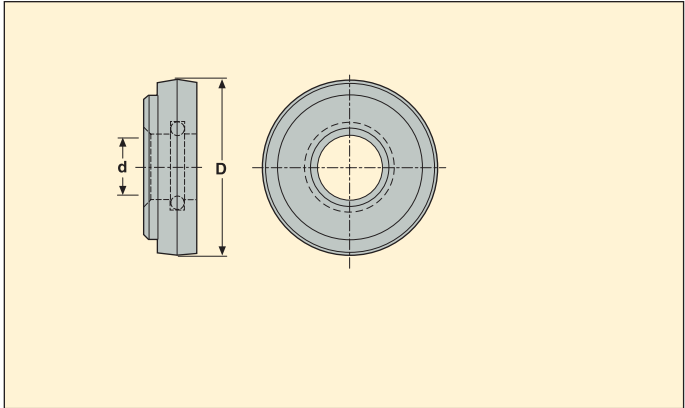

- For fitting into ER sealing nuts

For sealing nut size/Part No.	Sealing capacity d mm	Part No.	D mm	
ER 16/ 08B5875IC	4,5-5	01B58751605	13	
	5,5-6	01B58751606	13	
	6,5-7	01B58751607	13	
	7,5-8	01B58751608	13	
	8,5-9	01B58751609	13	
	9,5-10	01B58751610	13	
ER 25/ 08B587525IC	4,5-5	01B58752505	21	
	5,5-6	01B58752506	21	
	6,5-7	01B58752507	21	
	7,5-8	01B58752508	21	
	8,5-9	01B58752509	21	
	9,5-10	01B58752510	21	
	10,5-11	01B58752511	21	
	11,5-12	01B58752512	21	
	13,5-14	01B58752514	21	
15,5-16	01B58752516	21		
ER 32/ 08B587532IC	4,5-5	01B58753205	27	
	5,5-6	01B58753206	27	
	6,5-7	01B58753207	27	
	7,5-8	01B58753208	27	
	8,5-9	01B58753209	27	
	9,5-10	01B58753210	27	
	10,5-11	01B58753211	27	
	11,5-12	01B58753212	27	
	13,5-14	01B58753214	27	
	15,5-16	01B58753216	27	
	17,5-18	01B58753218	27	
	19,5-20	01B58753220	27	

Please check availability in current price and stock-list

For sealing nuts, see Accessories in ER collet chucks pages

Note: Sealing rings in size ER 40 are only available on request, please enquire. Not available in size ER 08 and ER 11



- Run-out 15 μm maximum at 3xd
- Clamping range of OZ type B collets is -0,5 mm

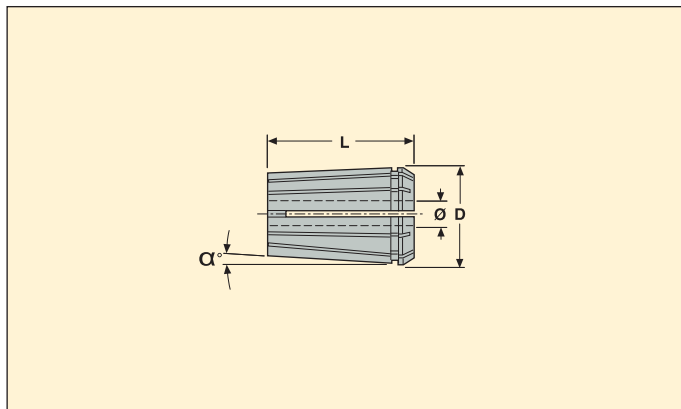

For chuck		Part No.	Capacity d mm	Dimensions in mm			α°
Capacity \varnothing mm	Size			Collet bore	D	L	
4-32	OZ 32 B	5883B103206	5,5-6	6,0	43,7	60,0	2,52
	OZ 32 B	5883B103208	7,5-8	8,0	43,7	60,0	2,52
	OZ 32 B	5883B103210	9,5-10	10,0	43,7	60,0	2,52
	OZ 32 B	5883B103212	11,5-12	12,0	43,7	60,0	2,52
	OZ 32 B	5883B103214	13,5-14	14,0	43,7	60,0	2,52
	OZ 32 B	5883B103216	15,5-16	16,0	43,7	60,0	2,52
	OZ 32 B	5883B103218	17,5-18	18,0	43,7	60,0	2,52
	OZ 32 B	5883B103220	19,5-20	20,0	43,7	60,0	2,52
	OZ 32 B	5883B103225	24,5-25	25,0	43,7	60,0	2,52
	OZ 32 B	5883B103232	31,5-32	32,0	43,7	60,0	2,52

Please check availability in current price and stock-list

EPB 5867 - Tapping chucks for synchronized tapping, with micro-compensation

Combined Weldon and Whistle Notch shank

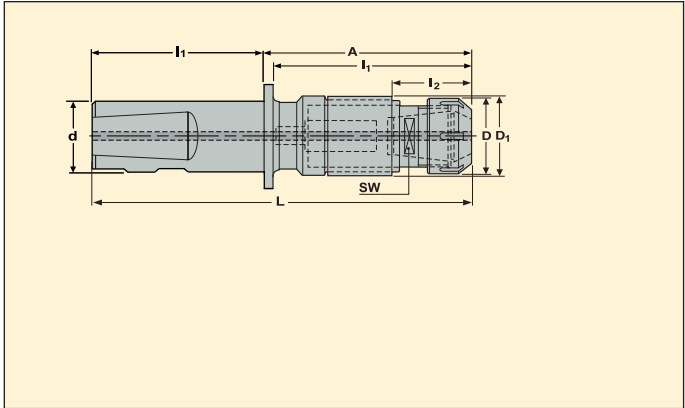

- Inbuilt axial micro flexure (+/- 0,5 mm) prevents from tapping tap stress
- Tap fitting based on ER tapping collets with square drive
- Maximum coolant pressure 80 bar

Shank d mm	Tapping range	Part No.	Size	Dimensions in mm							Balancing	
				A	D	D ₁	L	I ₁	I ₂	SW		
20	M2-M5	BW22058671151	ER 11	51,9	18,7	23,5	102,7	49,1	25,2	12,7	-	0,20
25	M4-M12	BW22558672069	ER 20	68,7	34	34,6	119,5	-	40,1	22,3	-	0,40
	M8-M20	BW22558672588	ER 25	88,1	41,7	44	138,9	-	42,0	28,0	-	0,80
	M16-M30	BW225586740117	ER 40	117,1	63	62	167,9	-	50,7	39,7	-	2,10

Accessories

For size	Locking key	Spanner
ER 11	5680092-03	03B587511UM
ER 20	5680092-04	03B587520UM
ER 25	5680092-05	03B587525
ER 40	5680092-06	03B587540

Spare Parts

For size	Nut
ER 11	5533050-07
ER 20	5533051-02
ER 25	5533051-03
ER 40	5533051-05

Please check availability in current price and stock-list

EPB 5867 - Tapping chucks for synchronized tapping, with micro-compensation

Cylindrical

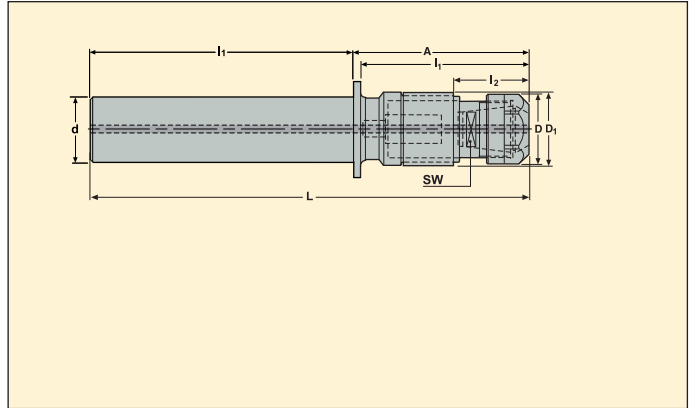

- Inbuilt axial micro flexure (+/- 0,5 mm) prevents from tapping tap stress
- Tap fitting based on ER tapping collets with square drive
- Maximum coolant pressure 80 bar

Shank d mm	Tapping range	Part No.	Size	Dimensions in mm							Balancing	 KG
				A	D	D ₁	L	I ₁	I ₂	SW		
16	M2-M5	BD01658671152	ER 11	51,9	18,7	23,5	96,4	–	25,2	12,7	–	0,20
20	M4-M12	BD02058672069	ER 20	68,7	34,0	34,6	119,5	–	40,3	22,0	–	0,40

Accessories

For size	Locking key	Spanner
ER 11		
ER 11	5680092-03	03B587511UM
ER 20	5680092-04	03B587520UM

Spare Parts

For size	Nut
ER 11	
ER 11	5533050-07
ER 20	5533051-02

Please check availability in current price and stock-list

EPB 393.14 - ER tapping collets with square drive



- For EPB 5867 tapping chucks

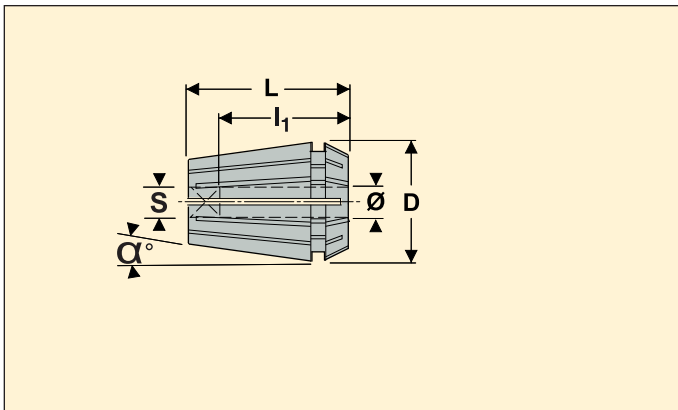

For tap size	For collet chuck size	Part No.	Dimensions in mm					
			∅ mm	Square mm	D	L ₁	L	α°
DIN M2 / DIN M2.5	ER 11	393.14-11D028X021	2,8	2,1	11,3	12	18,0	8
DIN M3 / DIN M5	ER 11	393.14-11D035X027	3,5	2,7	11,3	14	18,0	8
DIN M3.5	ER 11	393.14-11D040X030	4,0	3,0	11,3	14	18,0	8
DIN M4 / DIN M6	ER 11	393.14-11D045X034	4,5	3,4	11,3	14	18,0	8
DIN M5 / DIN M6 / DIN M8	ER 11	393.14-11D060X049	6,0	4,9	11,3	14	18,0	8
DIN M4 / DIN M6	ER 20	393.14-20D045X034	4,5	3,4	20,8	18	31,5	8
DIN M5 / DIN M6 / DIN M8	ER 20	393.14-20D060X049	6,0	4,9	20,8	18	31,5	8
DIN M7 / DIN M9 / DIN M10	ER 20	393.14-20D070X055	7,0	5,5	20,8	18	31,5	8
DIN M8 / DIN M10 / ISO M8 / ISO M10	ER 20	393.14-20D080X063	8,0	6,3	20,8	22	31,5	8
DIN M12 / ISO M12	ER 20	393.14-20D090X071	9,0	7,1	20,8	22	31,5	8
ISO M10	ER 20	393.14-20D100X080	10,0	8,0	20,8	25	31,5	8
DIN M8 / DIN M10 / ISO M8 / ISO M10	ER 25	393.14-25D080X063	8,0	6,3	25,8	18	34,0	8
DIN M12 / ISO M12	ER 25	393.14-25D090X071	9,0	7,1	25,8	18	34,0	8
ISO M10	ER 25	393.14-25D100X080	10,0	8,0	25,8	18	34,0	8
DIN M14	ER 25	393.14-25D110X090	11,0	9,0	25,8	18	34,0	8
DIN M16	ER 25	393.14-25D120X090	12,0	9,0	25,8	18	34,0	8
DIN M18 / ISO M18 / ISO M20	ER 25	393.14-25D140X112	14,0	11,2	25,8	22	34,0	8
DIN M20	ER 25	393.14-25D160X120	16,0	12,0	25,8	25	34,0	8
DIN M16	ER 40	393.14-40D120X090	12,0	9,0	40,8	25	46,0	8
DIN M18 / ISO M18 / ISO M20	ER 40	393.14-40D140X112	14,0	11,2	40,8	25	46,0	8
DIN M20 / ISO M22	ER 40	393.14-40D160X125	16,0	12,5	40,8	25	46,0	8
DIN M22 / DIN M24 / ISO M24	ER 40	393.14-40D180X145	18,0	14,5	40,8	25	46,0	8
DIN M27 / ISO M27 / ISO M28 / ISO M30	ER 40	393.14-40D200X160	20,0	16,0	40,8	28	46,0	8
DIN M30 / DIN M32 / ISO M30	ER 40	393.14-40D220X180	22,0	18,0	40,8	28	46,0	8

Please check availability in current price and stock-list

EPB 39 - ER sealing rings

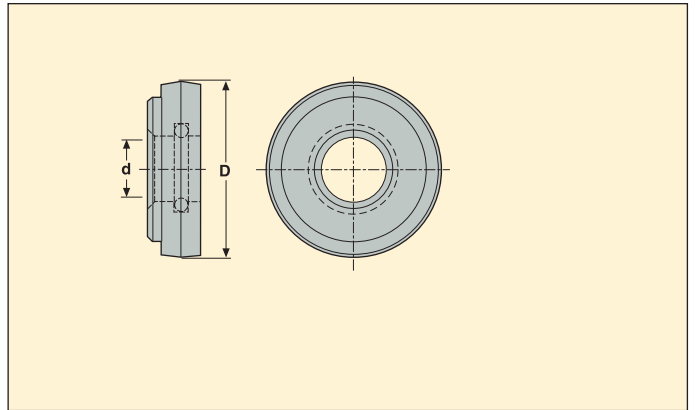

- To fit into nuts of EPB 5867 tapping chucks
- Other sizes available on request, see Guide page

For EPB 5867 chuck size	Sealing capacity d mm	Part No.	D mm
ER 20	5,5-6,0	3920.00600	16
	7,0-7,5	3920.00750	16
	8,5-9,0	3920.00900	16
	9,5-10,0	3920.01000	16
ER 25	5,5-6,0	3925.00600	21
	7,0-7,5	3925.00750	21
	8,5-9,0	3925.00900	21
	9,5-10,0	3925.01000	21

Please check availability in current price and stock-list

EPB 5283 - Quick change tapping chucks, with axial compensation

Combined Weldon and Whistle Notch shank



- With extension and compression

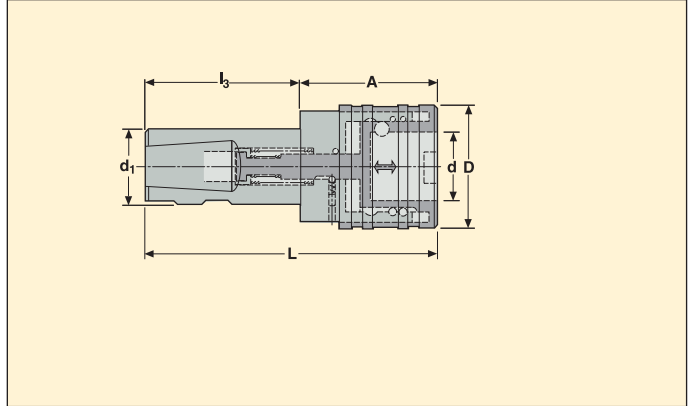

Shank d_1 mm	Capacity mm	Part No.	Tap adapter size	Dimensions in mm							Balancing	
				Compression	Extension	A	D	L	d	l_3		
25	M3-M12	T52832	2	7,5	7,5	40	39	103	19	63	-	0,43
32	M8-M20	T52833	3	12,5	12,5	64	59	137	31	73	-	1,18

Please check availability in current price and stock-list
For quick change tap adapters see page(s) 311-312

EPB 5285 - Quick change tap adapters, with torque limiter



- Torque is set according to the thread size

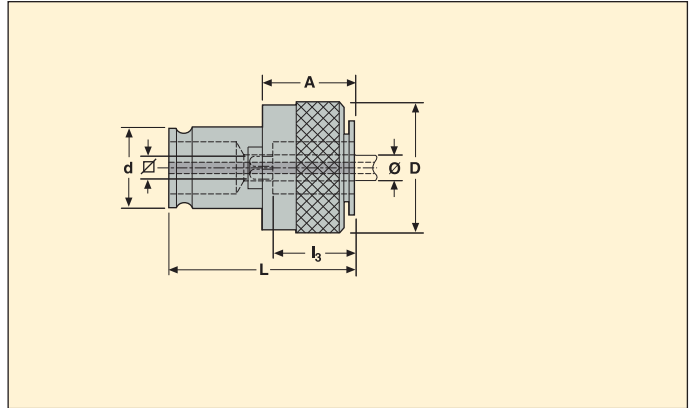

For quick change tapping chuck		For tap			Part No.	Dimensions in mm						
Range	Size	For thread size	Ø mm	Square mm		A	D	L	d	l ₃		
M3-M12	2	M3	3,5	2,7	T52852035027M3	25	32	46,5	19	17	0,16	
	2	M4	4,0	3,1	T52852040031M4	25	32	46,5	19	17	0,16	
	2	M4	4,5	3,5	T52852045035M4	25	32	46,5	19	17	0,16	
	2	M5	6,0	4,9	T52852060049M5	25	32	46,5	19	17	0,15	
	2	M6	6,0	4,9	T52852060049M6	25	32	46,5	19	17	0,15	
	2	M6	6,3	5,0	T52852063050M6	25	32	46,5	19	17	0,16	
	2	M8	6,0	4,9	T52852060049M8	25	32	46,5	19	17	0,15	
	2	M8	8,0	6,3	T52852080063M8	25	32	46,5	19	17	0,15	
	2	M10	7,0	5,5	T52852070055M10	25	32	46,5	19	17	0,16	
	2	M10	10,0	8,0	T52852100080M10	25	32	46,5	19	17	0,15	
	2	M12	9,0	7,1	T52852090071M12	25	32	46,5	19	17	0,16	
M8-M20	3	M8	6,0	4,9	T52853060049M8	34	50	69,0	31	30	0,49	
	3	M8	8,0	6,3	T52853080063M8	34	50	69,0	31	30	0,51	
	3	M10	7,0	5,5	T52853070055M10	34	50	69,0	31	30	0,51	
	3	M10	10,0	8,0	T52853100080M10	34	50	69,0	31	30	0,51	
	3	M12	9,0	7,1	T52853090071M12	34	50	69,0	31	30	0,52	
	3	M14	11,0	9,0	T52853110090M14	34	50	69,0	31	30	0,51	
	3	M16	12,0	9,0	T52853120090M16	34	50	69,0	31	30	0,51	
	3	M16	12,5	10,0	T52853125100M16	34	50	69,0	31	30	0,5	
	3	M18	14,0	11,0	T52853140110M18	34	50	69,0	31	30	0,49	
	3	M20	14,0	11,2	T52853140112M20	34	50	69,0	31	30	0,49	
	3	M20	16,0	12,0	T52853160120M20	34	50	69,0	31	30	0,48	
M14-M33	4	M20	16,0	12,0	T52854160120M20	45	72	100,5	48	44	1,56	
	4	M24	18,0	14,5	T52854180145M22	45	72	100,5	48	44	1,54	
	4	M22	18,0	14,0	T52854180140M24	45	72	100,5	48	44	1,55	
	4	M24	18,0	14,5	T52854180145M24	45	72	100,5	48	44	1,55	
	4	M27	20,0	16,0	T52854200160M27	45	72	100,5	48	44	1,52	
	4	M30	22,0	18,0	T52854220180M30	45	72	100,5	48	44	1,51	
	4	M33	25,0	20,0	T52854250200M33	45	72	100,5	48	44	1,46	

Please check availability in current price and stock-list
 For tap adapter code key, see page(s) 284

EPB 5241 - Quick change tap adapters, without torque limiter

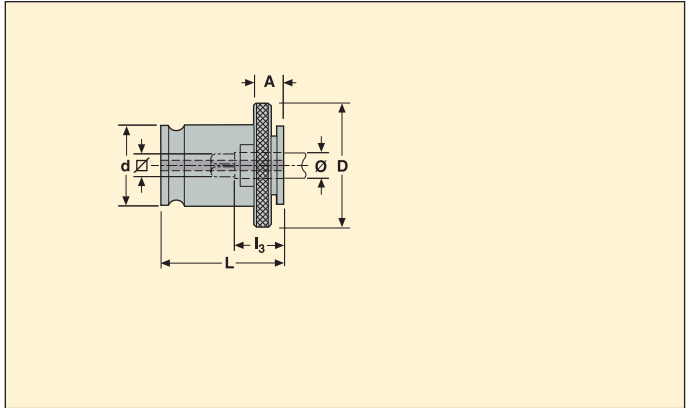

For quick change tapping chuck		For tap shank		Part No.	Dimensions in mm					 KG
Range	Size	∅ mm	Square mm		A	D	L	d	l ₃	
M3-M12	2	3,5	2,8	T52412035028	7	30	28,5	19	17	0,07
	2	4,0	3,1	T52412040031	7	30	28,5	19	17	0,07
	2	4,5	3,5	T52412045035	7	30	28,5	19	17	0,07
	2	6,0	4,9	T52412060049	7	30	28,5	19	17	0,06
	2	6,3	5,0	T52412063050	7	30	28,5	19	17	0,06
	2	7,0	5,5	T52412070055	7	30	28,5	19	17	0,06
	2	8,0	6,3	T52412080063	7	30	28,5	19	17	0,06
	2	9,0	7,1	T52412090071	7	30	28,5	19	17	0,06
	2	10,0	8,0	T52412100080	7	30	28,5	19	17	0,06
M8-M20	3	6,0	4,9	T52413060049	11	48	46,0	31	30	0,26
	3	7,0	5,5	T52413070055	11	48	46,0	31	30	0,26
	3	8,0	6,3	T52413080063	11	48	46,0	31	30	0,26
	3	9,0	7,1	T52413090071	11	48	46,0	31	30	0,25
	3	10,0	8,0	T52413100080	11	48	46,0	31	30	0,25
	3	11,0	9,0	T52413110090	11	48	46,0	31	30	0,25
	3	12,0	9,0	T52413120090	11	48	46,0	31	30	0,24
	3	12,5	10,0	T52413125100	11	48	46,0	31	30	0,24
	3	14,0	11,0	T52413140110	11	48	46,0	31	30	0,22
	3	14,0	11,2	T52413140112	11	48	46,0	31	30	0,23
	3	16,0	12,0	T52413160120	11	48	46,0	31	30	0,22
M14-M33	4	16,0	12,0	T52414160120	14	70	69,5	48	44	0,84
	4	18,0	14,0	T52414180140	14	70	69,5	48	44	0,82
	4	18,0	14,5	T52414180145	14	70	69,5	48	44	0,82
	4	20,0	16,0	T52414200160	14	70	69,5	48	44	0,79
	4	22,0	18,0	T52414220180	14	70	69,5	48	44	0,77
	4	25,0	20,0	T52414250200	14	70	69,5	48	44	0,73

Please check availability in current price and stock-list

EPB M211 - Assembly supports, Tool Boy



Part No.	For holder size(s)	Design	
M211H32	HSK-A32	1	7,20
M211H40	HSK-A40	1	7,20
M211H40E	HSK-E40	3	7,20
M211H50	HSK-A50	1	7,40
M211H63	HSK-A63	1	7,60
M211H100	HSK-A100	1	8,40
M211S30	SA30	2	7,20
M211S40	SA40	2	7,40
M211S50	SA50	1	9,20
M211C3	Seco-Capto C3	3	7,20
M211C4	Seco-Capto C4	3	7,20
M211C5	Seco-Capto C5	3	7,40
M211C6	Seco-Capto C6	3	7,60
M211C8	Seco-Capto C8	3	8,40
M211V30	VDI30	4	6,30
M211V40	VDI40	4	6,60
M211V50	VDI50	4	7,40

Tool Boy assembly supports are made of a base unit and a head. All heads are interchangeable.

EPB 5095 – HSK locking units, TF

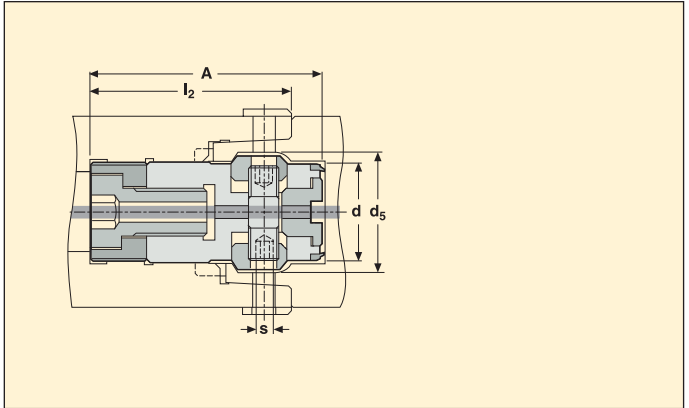

- For manual clamping of holders HSK-C and HSK-A with radial bore

For HSK-A/C	Part No.	Dimensions in mm					 KG
		A	d	d ₅	l ₂	s	
HSK-A/C 32	24H509532	40	16,7	21,0	32,5	2,5	0,06
HSK-A/C 40	24H509540	48	20,5	25,5	40,5	3,0	0,1
HSK-A/C 50	24H509550	60	25,5	32,0	50,5	4,0	0,2
HSK-A/C 63	24H509563	75	33,5	40,0	65,5	5,0	0,43
HSK-A/C 80	24H509580	92	41,5	50,0	80,0	6,0	0,82
HSK-A/C 100	24H509510	110	52,5	63,0	98,0	8,0	1,59

Spindle machining advice, see page(s) 318

Accessories

For HSK	Locking key	Spanner
HSK-A/C 32	H2.5-2D	03E509532
HSK-A/C 40	03M03	03E509540
HSK-A/C 50	H04-4	03E509550
HSK-A/C 63	H05-4	03E509563
HSK-A/C 80	H06-4	03E509580
HSK-A/C 100	03M08	03E509510

Spare Parts

For HSK	O-ring
HSK-A/C 32	930R14
HSK-A/C 40	930R17
HSK-A/C 50	930R21
HSK-A/C 63	930R27
HSK-A/C 80	930R34
HSK-A/C 100	930R43

Please check availability in current price and stock-list

EPB BR1 – HSK locking flange mounts, TF

HSK/ ISO 12164



- For manual clamping of holders HSK-C and HSK-A with radial bore
- Flange with radial and angular adjustment

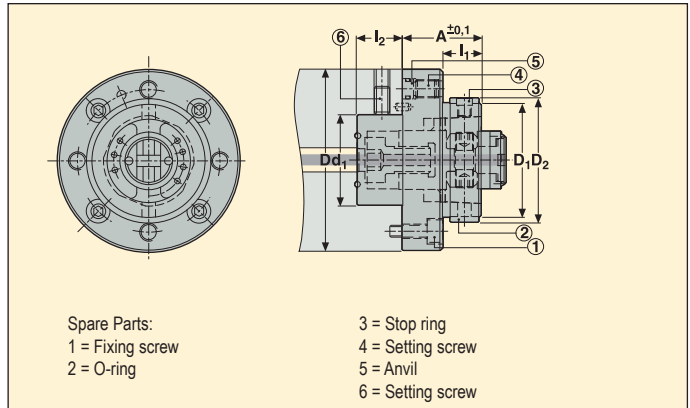

For HSK-A/C	d ₁ mm	Part No.	Dimensions in mm						KG
			A	D	D ₁	D ₂	I ₁	I ₂	
HSK A/C 50	40	BR14050955035	35	80	50	55	17	20	1,05
HSK A/C 63	50	BR15050956343	43	100	63	70	23	27	1,95
HSK A/C 100	80	BR18050951070	70	140	100	110	42	35	6,56

Spindle machining advice, see page(s) 318

Spare Parts

For HSK	Anvil	Fixing screw	O-ring	Setting screw	Stop ring
HSK A/C 50	17C090045	950D0625	00X509550	19A71040	19DS06010005002
HSK A/C 63	17C120065	950D0825	00X509563	19A71060	19DS08012506002
HSK A/C 100	17C120065	950D1035	00X5095100	19A71060	19DS12017510002

Please check availability in current price and stock-list

The assembly spanners and locking keys for the TF units are shown on page(s) 314, the indexing pins are shown on page(s) 318

EPB BR2 – HSK locking flange mounts, TF

HSK/ISO 12164



- For manual clamping of holders HSK-C and HSK-A with radial bore
- Short flange, with radial adjustment

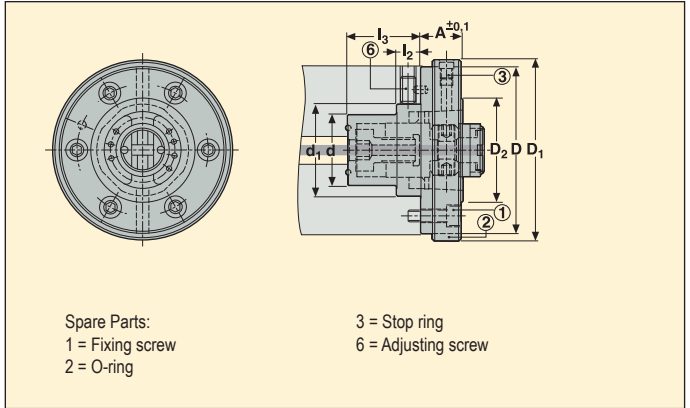

For HSK A/C	d ₁ mm	Part No.	Dimensions in mm							KG
			A	D	D ₁	D ₂	d	I ₂	I ₃	
HSK A/C 50	44	BR24450955020	20	80	88	50	34	11,5	35	1,05
HSK A/C 63	56	BR25650956325	25	100	108	63	44	13,5	45	1,93
HSK A/C 100	88	BR28850951030	30	140	150	100	65	29,0	75	5,15

Spindle machining advice, see page(s) 318

Spare Parts

For HSK	Adjusting screw	Fixing screw	O-ring	Stop ring
HSK A/C 50	19A71040	950D0625	00X50955080	19DS06010005002
HSK A/C 63	19A71060	950D0825	00X509563100	19DS08012506002
HSK A/C 100	19A71060	950D1035	00X5095100140	19DS12017510002

Please check availability in current price and stock-list
 The assembly spanners and locking keys for the TF units are shown on page(s) 314, the indexing pins are shown on page(s) 318

EPB BR3 - HSK locking flange mounts, TF

HSK/ ISO 12164



- For manual clamping of holders HSK-C and HSK-A with radial bore
- Short and slim flange, with radial adjustment

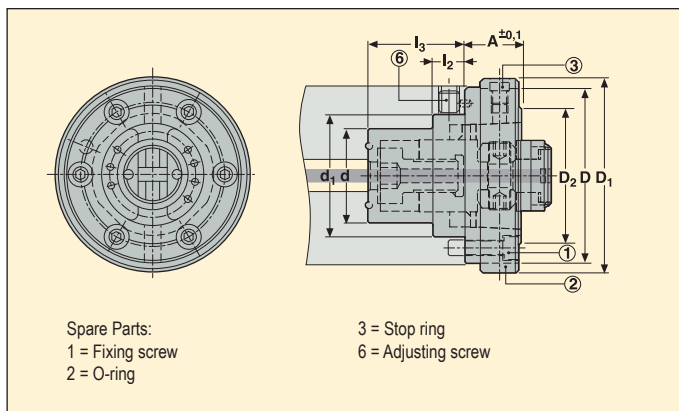

For HSK-A/C	d ₁ mm	Part No.	Dimensions in mm							KG
			A	D	D ₁	D ₂	d	l ₂	l ₃	
HSK A/C 50	44	BR34450955020	20	63	70	50	34	11,5	35	0,72
HSK A/C 63	56	BR35650956325	25	80	88	63	44	13,5	45	1,41

Spindle machining advice, see page(s) 318

Spare Parts

For HSK	Adjusting screw	Fixing screw	O-ring	Stop ring
HSK A/C 50	19A71030	950D0525	00X50955063	19DS06010005002
HSK A/C 63	19A71040	950D0630	00X50956380	19DS08012506002

Please check availability in current price and stock-list
 The assembly spanners and locking keys for the TF units are shown on page(s) 314, the indexing pins are shown on page(s) 318

Machining advice for fitting the HSK locking units, TF

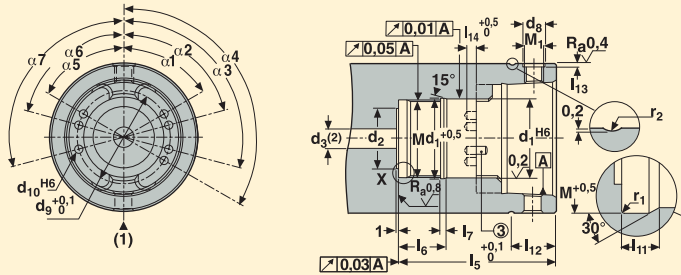

Spindle HSK Form C	Dimensions in mm													
	d_1^{H6}	d_2	d_3 max	d_8	d_9	d_{10}^{H12}	$l_5^{0/+0,1}$	l_6	l_7	l_{11}	l_{12}	l_{13}	$l_{14}^{0/+0,5}$	
32	17	12	4,2	5	20	1,5	32,5	10	1,5	2,5	11	0,6	3,5	
40	21	16	5	6,5	25	2	40,5	12	2	3	13	0,8	3,5	
50	26	20	6,8	7,5	31	2,5	50,5	15	2	4	15	0,8	3,5	
63	34	26	8,4	9,5	39,5	3,5	65,5	20	2,5	5	18	1	4	
80	42	30,5	10,2	12	49,5	4,5	80	22	3	5	23	1,2	5	
100	53	30,5	12	14	62	4,5	98	26	3	5	28	1,5	5	

(1) Position of the access to the unit clamping screw, (2) If through coolant

HSK	M	M1	r_1	r_2	$\alpha 1^\circ$	$\alpha 2^\circ$	$\alpha 3^\circ$	$\alpha 4^\circ$	$\alpha 5^\circ$	$\alpha 6^\circ$	$\alpha 7^\circ$		
32	M16 x 1	M4	0,4	1,4	50	75	100	127,5	50	80	105		
40	M20 x 1	M5	0,4	1,4	52,5	75	100	127,5	52,5	80	105		
50	M25 x 1	M6	0,4	1,6	55	75	100	125	55	80	105		
63	M33 x 1	M8	0,4	1,6	60	75	105	120	60	75	105		
80	M41 x 1,5	M10	0,8	2,2	60	75	105	120	60	75	105		
100	M52 x 1,5	M12	0,8	2,2	45	75	105	135	45	75	105		

Accessories

HSK	Indexing pin DIN 1481 (3)	
32	1,5 x 6	925E01506
40	2 x 6	925E02006
50	2,5 x 6	925E02506
63	3,5 x 6	925E03508
80	4,5 x 10	925E04510
100	4,5 x 10	925E04510

Machining advice for fitting the HSK locking flange mounts, TF, type BR1

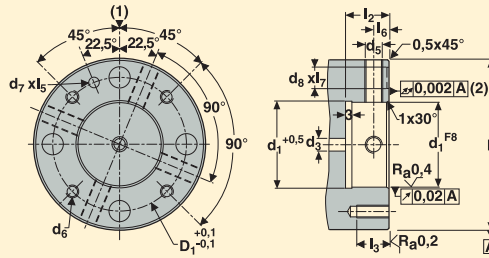

HSK Form A Form C	Dimensions in mm											d_5	d_6
	d_1^{F8}	D	$D_1^{-0.1/0.1}$	d_3	d_7^{H11}	d_8	l_2	l_3	l_5	l_6	l_7		
32	30	60	44	4	5	10	12,3	14	3	7	0,5	M8 x 0,75	M5
40	35	70	53	5	5	10	15,3	14	3	7	0,5	M8 x 0,75	M6
50	40	80	63	6	5	10	20,3	16	3	7	0,5	M8 x 0,75	M6
63	50	100	79	8	5	12	27,3	16	3	8	0,8	M10 x 1	M8
80	60	117	96	10	6	12	35,3	20	4	8	0,8	M10 x 1	M8
100	80	140	119	12	6	12	35,3	20	4	8	0,8	M10 x 1	M10

(1) Position of the access to the unit clamping screw, (2) Not convex

Machining advice for fitting the HSK locking flange mounts, TF, type BR2

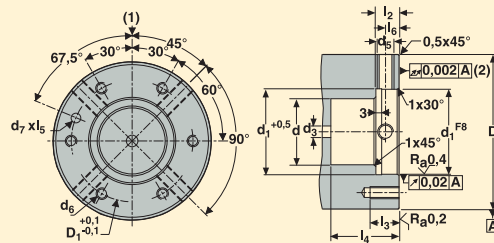

HSK Form A Form C	Dimensions in mm											d_5	d_6
	d_1^{F8}	D	$D_1^{-0,1/+0,1}$	$d_1^{0/+0,1}$	d_3	d_7^{H11}	l_2	l_3	l_4	l_5	l_6		
32	28	55	42	22,2	4	5	10	14	22,3	3	7	M5 x 0,5	M5
40	35	63	53	27,2	5	5	12	14	30,3	3	7	M6 x 0,75	M6
50	44	80	63	34,2	6	5	12	16	35,3	3	7	M8 x 0,75	M6
63	56	100	79	44,2	8	5	14	16	45,3	3	8	M10 x 1	M8
80	68	117	96	52,2	10	6	23	20	60,3	4	8	M10 x 1	M8
100	88	140	119	65,2	12	6	30	20	75,3	4	8	M10 x 1	M10

(1) Position of the access to the unit clamping screw, (2) Not convex

Machining advice for fitting the HSK locking flange mounts, TF, type BR3

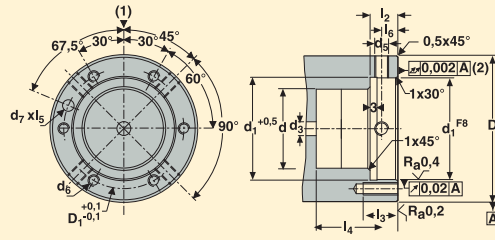

HSK Form A Form C	Dimensions in mm											d ₅	d ₆
	d ₁ ^{F8}	D	D ₁ ^{-0,11+0,1}	d ₁ ^{0+0,1}	d ₃	d ₇ ^{H11}	l ₂	l ₃	l ₄	l ₅	l ₆		
32	28	40	33	22,2	4	3	10	12	22,3	3	6	M4 x 0,5	M3
40	35	50	41	27,2	5	4	12	12	30,3	3	7	M5 x 0,5	M4
50	44	63	52	34,2	6	5	12	15	35,3	3	7	M6 x 0,75	M5
63	56	80	66	44,2	8	5	14	15	45,3	3	8	M8 x 0,75	M6
80	68	100	82	52,2	10	5	23	17	60,3	3	8	M10 x 1	M8

(1) Position of the access to the unit clamping screw, (2) Not convex

Range overview

Easyshrink® 15 : compact Shrinkfit device

Induction heating and air cooling in compact design.



ZFM08IN

Packs Easyshrink® 20 : Three new Shrinkfit packs resulting from efficient “combinations” of previous Easyshrink® 20 modules replace these previous individual modules.

Only one part number to order a selected pack, always including heating, cooling (air and/or water) and shrink depth setting (with or without height measuring) features.



ZFM07IN10



ZFM07IN20



ZFM07IN30

Common heating features of Easyshrink® 15 and Packs Easyshrink® 20

Induction heating with shrink grip and shrink release capacity 3 to 32 mm for carbide and heavy metal, 6 to 32 mm for steel and HSS. Induction heating achieves shrink grip and shrink release in a few seconds.

- New 'Automatic' and 'Programmable' heating mode types are available on Easyshrink® Packs N°1, 2, 3.

Note: The same new heating mode types are as well available on latest Easyshrink® 15 devices with '5600 sticker', and can be achieved on earlier Easyshrink® 20 and 15 devices by upgrading them with a command cards kit '5600 compatible'.

- 6 Automatic heating modes:

- Automatic OPTIM modes optimise the shrink grip & release heating cycles in relation to the Shrinkfit holder front end type (standard, slim, reinforced) when in presence of carbide or heavy metal tool shanks: by supplying the exact required heating cycle, holders service life is maximised.

- Automatic STEEL modes ensure stronger heating cycles, for reliable shrink release of tools with HSS or steel shanks.

- How to use an Automatic mode: User selects the required automatic mode on the control panel, no need to select the diameter, then starts the heating cycle, which stops automatically.

- 2 Programmable heating modes:

- The programmable PRG modes enable input of customised shrink grip or release heating cycles, e.g. for custom made holders and tools.

- How to use a Programmable mode: User first programs the customised cycle, in one of the 50 files of modes PRG1 and PRG2, using the control panel. Every time afterwards when the customised operation is needed, user scrolls to the programmed file on the control panel, then starts the heating cycle, which stops automatically.



Easyshrink® 15

Compact Shrinkfit device. Supports carrying Shrinkfit holders can be slid from station to station (1 heating and 2 ventilator fans air cooling stations), operator doesn't touch hot spots. Cooling made in idle time, approx. 3 minutes with finned cooling tubes or 8 minutes with cooling cones. Plate made from hard anodized aluminium allowing smooth sliding. The universal sliding support(s) can be equipped with interchangeable support rings in order to carry any kind of Shrinkfit holder. The cooling cone(s) direct the air flow towards holder's front end, for faster cooling.

Delivery content:

Device is delivered with:

- 5 Standard (full set) heat focusing stoppers for 3 to 32 mm.
- 1 Universal sliding support.
- 1 Support ring for HSK63-A/C/E & HSK80-B/D/F holders.
- 1 Air cooling cone.
- A pair of gloves.
- Operating instructions.

Connections:

AC 3x400V + PE/ 16 A/ 50-60Hz. 3 meter cable is supplied.



Accessories and Spare parts for Easyshrink® 15

Only a few accessories related to the Shrinkfit holders used have to be ordered separately.

Required Easyshrink® 15 accessories:

Only one support ring for HSK63-A/C/E & HSK80-B/D/F is in the delivery content: In order to carry different Shrinkfit holders types (SA, HSK, Seco-Capto™), please order more support rings.

Optional Easyshrink® 15 accessories:

More universal sliding supports will provide idle cooling cycles: e.g. with 3 sliding supports, all 3 device's stations can be operated simultaneously.

More cooling cones may be useful when several sliding supports are in use.

When required, 5 interchangeable split heat focusing stoppers for tools with a larger head than shank, and a fitting ring, are available as Accessories.

Other optional accessories:

Several items can be added to the Easyshrink® 15 device operation: - E.g. finned cooling tubes (ZFAR02C...), or the refrigerated cooling bells water cooler (ZFM07RE1).

See Accessories and spare parts pages.



Packs Easyshrink® 20 : N°1, 2, 3

Easy to order, easy to use: Only one part number to order a selected pack, always including heating, cooling (air and/or water) and shrink depth setting (with or without height measuring) features.

Pack Easyshrink® 20 N°1, ZFM07IN10

A complete set with induction heating, 1 operating + shrink depth setting station and 2 cooling stations.



Pack Easyshrink® 20 N°2, ZFM07IN20

A complete set with induction heating, rotary plate of 3 operating + shrink depth setting + cooling stations.



Pack Easyshrink® 20 N°3, ZFM07IN30

A complete set with induction heating, rotary plate of 3 operating + shrink depth setting + cooling stations, height measuring and a refrigerated cooling bells water cooler.



Delivery content:

All Packs are delivered with:

A pair of gloves.

Five standard (full set) heat focusing stoppers for 3 to 32 mm, their storage rack and adapter.

Note: When required, 5 split heat focusing stoppers for tools with a larger head than shank are available as Accessories.

A set of 4 standard stop rods in a rack.

Operating instructions are supplied.

Additional in Packs N°1 and 2:

Two cooling cones

Connections:

All Packs:

AC 3x400V + PE/ 16 A/ 50-60Hz/ Differential breaker 30 mA. 3 meter cable is supplied. Air 3 to 6 bar/ pipe internal Ø 7 mm required (for heating system).

AC 1x230V + PE/5A/50-60Hz, cable with a DE/FR electrical plug is supplied (for air cooling).

Additional for Pack N°3 :

AC 1x230V + PE/5A/50-60Hz, cable with a DE/FR electrical plug is supplied (for refrigerated water cooler).

Packs Easyshrink® 20 : N°1, 2, 3

Accessories and Spare parts for Packs Easyshrink® 20

Only a few accessories related to the Shrinkfit holders used have to be ordered separately.

For shrink grip and shrink release operating:

Required at minimum: 1 finned support per type of Shrinkfit holder taper.

For air cooling:

Required at minimum: 1 finned support or 1 support ring per type of Shrinkfit holder taper. More supports and rings allow up to 3 simultaneous stations equipment.

For shrink depth setting:

Packs are delivered with a set of 4 standard stop rods with 4,2 mm front end for Shrinkfit holders \varnothing 6 mm and above.

A set of 4 thin stop rods with 2,5 mm front end for Shrinkfit holders \varnothing 3 to 5 mm is available as accessories.

See also depth comparators, depth rulers and stop end screw setting adapters available as accessories.

For height measuring of Pack Easyshrink 20 N°3:

Required at minimum: 1 tool supporting sleeve for stop rod per \varnothing of tool shank bore.

For water cooler of Pack Easyshrink 20 N°3:

Required at minimum: 1 contact bush per size of Shrinkfit holder front end.

More contact bushes allow simultaneous cooling of up to 2 holders.

See Easyshrink Accessories and Spare parts pages.

Common and dedicated features of Packs Easyshrink® 20

Heating features

See previous 'Common heating features of Easyshrink® 15 and Packs Easyshrink® 20'



Bearing features

Operating stations hold the finned support with tool holder during the heating and cooling cycles.

Pack N° 1 has one operating station with height setting.

In Packs N°2 and 3, all three stations of the rotary plate are operating, shrink depth setting and cooling stations.

Air cooling features

Ventilator fans stream air through the finned support, towards the finned cooling tube fitted onto the tool holder front end or towards the cooling cone fitted onto finned supports: cooling time approx. 3 minutes with finned supports, approx. 7 minutes with cooling cones.

Pack N°1 has 2 cooling stations.

In Packs N°2 and 3, all three stations are cooling stations. The rotary plate prevents the user having any contact with hot holders: by a simple plate rotation, each station switches from the heating position to a cooling position. Each station is equipped with an LED indicator which switches on automatically when the table is rotated into a cooling position (timing approx. 3 min).

Note : the refrigerated cooling bells water cooler of Pack N°3 achieves shorter cooling times, see specific description.



Shrink depth setting features

The fittings consist of a stop rod adjusting system, with a setting wheel (adjusting range of the fitted stop rod is 60 mm) and a set of stop rods.

Pack N° 1 has one operating station with shrink depth setting.

In Packs N°2 and 3, all three stations of the rotary plate have shrink depth setting.

Shrink depth setting instructions

A required stop rod is fitted into the shrink depth setting system, and adjusted by the setting wheel to the required Shrinkfit depth. A depth comparator or ruler (available as accessories) is used to control the stop rod front end position in reference to the holder's front face. The tool shank will bear onto the stop rod front end when fitted into the holder during the shrink grip cycle. The stop rod can also be used during the shrink release cycle to push a broken tool out from the holder.

Note: Stop rod used in combination with the height measuring of Pack N°3, allows the tool's gauge length setting. Stop rod used in Packs N°1 and 2 allows only the shrink depth setting."



Height measuring features (of Pack Easyshrink® 20 N°3)

The height measuring fittings include:

- A fine adjustment of the sliding support using a height adjustment setting wheel.
- A digital rule to control the sliding support /comparator position (0,01 mm display).
- A comparator (0,01 mm) fixed onto the inductor sliding support.

Height measuring instructions:

Precise cutting edge gauge length can be achieved when the stop rod position is set taking into account the actual tool to be shrink gripped: therefore, the shrink depth setting fittings (stop rod adjustment with a setting wheel) have to be used in combination with the height measuring fittings (depth comparator or depth rulers, fine adjustment setting wheel, digital rule with display, set of standard stop rods). The tool shank has to be located onto the stop rod front end, in order to adjust the stop rod until the cutter front end reaches the required position controlled by the digital rule and comparator. Gauge length precision $\pm 0,05$ mm is possible.



Easyshrink® refrigerated cooling bells water cooler

Note: a refrigerated cooling bells water cooler is part of Pack Easyshrink® 20 N°3. It can be added to the Easyshrink® 15 device as well as to the Packs Easyshrink® 20 N° 1 and 2.

The cooler includes a refrigeration unit and a support unit for cooling bells and contact bushes. Two aluminium bells are cooled by refrigerated water and placed over contact bushes onto the front end of the holder, cooling time approx. 1 minute. There are 2 storing rests for the bells and 6 storage locations for contact bushes.

Note: If needed, one storage station can be created by the user on the body, by moving the storing rests towards the column (1 more holder placed on support rings can then be cooled by the two bells). The refrigeration unit can be stored under or to one side of the device. Operating with tap water, to be changed at minimum every 6 months. Operating instructions are supplied.



Accessories: Contact bushes for cooling bells

The bushes in contact with the holder front end disperse heat towards the refrigerated cooling bell. Select the suitable contact bushes available as accessories to be ordered separately, see Accessories for Easyshrink.

Required at minimum: 1 contact bush per size of Shrinkfit holder front end.

More contact bushes allow simultaneous cooling of up to 2 holders.

Connections:

AC 1x230V + PE/5A/50-60Hz, cable with a DE/FR electrical plug is supplied.

Accessories for Easyshrink® 15 and Packs Easyshrink® 20

Finned supports (A)

Required to provide positioning of the tool holder onto the support module (corner plate or box) during heating and cooling. Designed to let air stream towards the finned cooling tube or cooling cone. Select the suitable sizes for HSK, SA, DIN, JIS-BT, ANSI or Seco-Capto™ holder tapers, see Product pages.



Finned cooling tubes (B)

Fins in contact with the holder's front end offer a large surface area for fast heat dispersal; cooling time approx. 3 minutes. Select the suitable tube sizes for type 5600 or 5603 Shrinkfit holders.



Air cooling cone (C)

The cone is a simple solution to direct the air stream towards the holder's front end (instead of using finned cooling tubes); cooling time is approx. 7 minutes. The unique cone (Part No. ZFAR03C) fits all holders. The cone fits directly onto stations of support boxes.



Support ring (E)

Note: Support rings are suitable for the two cooling stations of the three-station support boxes, the storage stations of the refrigerated water cooling bells unit, as an economical means of direct holder bearing, instead of using finned supports. Select the suitable support rings for HSK, DIN, JIS-BT, ANSI or Seco-Capto™ holder tapers.

Sets of stop rods (G)+(H)

Stop rods are required in conjunction with the shrink depth setting fittings. Packs Easyshrink® 20 are delivered with a set of 4 standard stop rods with 4,2 mm front end for Shrinkfit holders \varnothing 6 mm and above. A set of 4 thin stop rods with 2,5 mm front end for Shrinkfit holders \varnothing 3 to 5 mm is available as accessories.

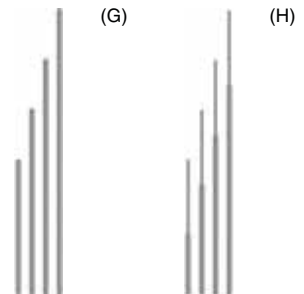

Tool supporting sleeves for stop rods (for Packs Easyshrink® 20 N°3 only)

These sleeves can be used for locating the cutter onto the stop rod, to free both hands, when using the direct tool height measuring. Select the suitable sleeve diameters in regard to the tool shank diameters:

Type 05RS5600 sleeves are for tool shanks \varnothing (d_2) 6 to 32 mm and for current standard stop rods (d_1) 4,2 mm.

Type 05RS5800 sleeves are for tool shanks \varnothing (d_2) 3, 4 or 5 mm and slim stop rods (d_1) 2,5 mm.



Depth comparator for Shrinkfit depth setting

Part No. Z847031. User friendly measuring accessory, to set stop rod's position for reliable Shrinkfit depth on Packs EasyShrink® 20. The distance between stop rod's front and holder's front face is directly readable on the comparator. Depth capacity 25 to 75 mm, comparator resolution 0.010 mm. Comparator's delivery content includes two comparator stylus (\varnothing 8 mm and slim \varnothing 5 mm) and a magnetic storage sleeve also used for calibrating. When using a stop screw, the depth comparator allows also to measure the stop screw position.



Depth rulers for Shrinkfit depth setting

A depth ruler is an economic alternative to the depth comparator, enabling easy setting of the stop rods on Packs Easyshrink® 20 according to a required Shrinkfit depth. The distance between stop rod's front and holder's face is directly readable on the ruler.

Depth ruler size 1 (\varnothing 2,5 mm) for Shrinkfit holders dia. 3 to 5 mm, depth capacity 10 to 35 mm: Part No. ZFCM07IN282.

Depth ruler size 2 (\varnothing 5 mm) for Shrinkfit holders dia. 6 to 32 mm, depth capacity 20 to 75 mm: Part No. ZFCM07IN254.

Note: Depth comparator and depth rulers can also be used to check the Shrinkfit depth when using the stop end screw of type 5600 or 5603 Shrinkfit holders: stop screws are mainly used with Easyshrink® 15 (stop screws are also possible with Packs Easyshrink® 20, instead using the stop rods).



Stop end screw setting adapters with hexagonal back-end

Stop screw setting adapters type 05R5600 have hexagonal sizes suitable for stop screws of current Shrinkfit holders type 5600 or 5603.

The adapter bore is oversized in relation to the cutting tool shank, and the adapter shank is undersized to the Shrinkfit holder bore. The tool is placed into the adapter. The hexagonal nose on adapter's back end engages the stop screw to set it until the cutter front end reaches the required position, taking into account the adapter's length from the bottom of the bore to the back end of the shank (L = 80 mm).

Available for tool shanks \varnothing 6 to 32 mm.

When using Packs Easyshrink® 20 stop rod setting features, there is no need for a stop screw, nor a stop screw setting adapter with hexagonal back-end. Using stop rods instead of stop screws eliminates the risks of vibrations (unbalance caused by a loose screw).

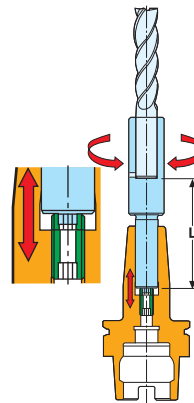

Easyshrink® 15, heating and air cooling device



	Part No.	Capacity, tool shank mm		Shrinking time, approx.	Dimensions in mm			 KG
		Carbide/ Heavy metal	Steel/ HSS		Width	Depth	Height	
<ul style="list-style-type: none"> • Induction heating • 1 operating + cooling station • 1 cooling station 	ZFM08IN	∅ 3-32	∅ 6-32	10 sec.	830	410	910	45,0

Pack Easyshrink® 20, N°1



	Part No.	Capacity, tool shank mm		Shrinking time, approx.	Dimensions in mm			 KG
		Carbide/ Heavy metal	Steel/ HSS		Width	Depth	Height	
<ul style="list-style-type: none"> • Induction heating • 1 operating + shrink depth setting station • 2 cooling stations 	ZFM07IN10	∅ 3-32	∅ 6-32	10 sec.	688	570	960	60,0

Pack Easyshrink® 20, N° 2



	Part No.	Capacity, tool shank mm		Shrinking time, approx.	Dimensions in mm			 KG
		Carbide/ Heavy metal	Steel/ HSS		Width	Depth	Height	
<ul style="list-style-type: none"> • Induction heating • Rotary plate of 3 operating + shrink depth setting + cooling stations 	ZFM07IN20	∅ 3-32	∅ 6-32	10 sec.	759	570	960	65,0

Pack Easyshrink® 20, N° 3



	Part No.	Capacity, tool shank mm		Shrinking time, approx.	Dimensions in mm			 KG
		Carbide/ Heavy metal	Steel/ HSS		Width	Depth	Height	
<ul style="list-style-type: none"> • Induction heating • Rotary plate of 3 operating + shrink depth setting + cooling stations • Height measuring • Refrigerated cooling bells water cooler 	ZFM07IN30	∅ 3-32	∅ 6-32	10 sec.	1084	570	960	126,0

Easyshrink® refrigerated cooling bells water cooler





	Part No.	Cooling Bells Qty.	Cooling time approx.	Dimensions in mm			
				Width	Depth	Height	
<ul style="list-style-type: none"> • Refrigeration unit • Support unit 	ZFM07RE1	2	1 min	325	507	762	60,0

Contact bushes are required, see page 337

This fast cooling equipment can be added onto Easyshrink® 15 or Packs Easyshrink® N°1 & N°2; it is part of Pack Easyshrink® 20 N°3

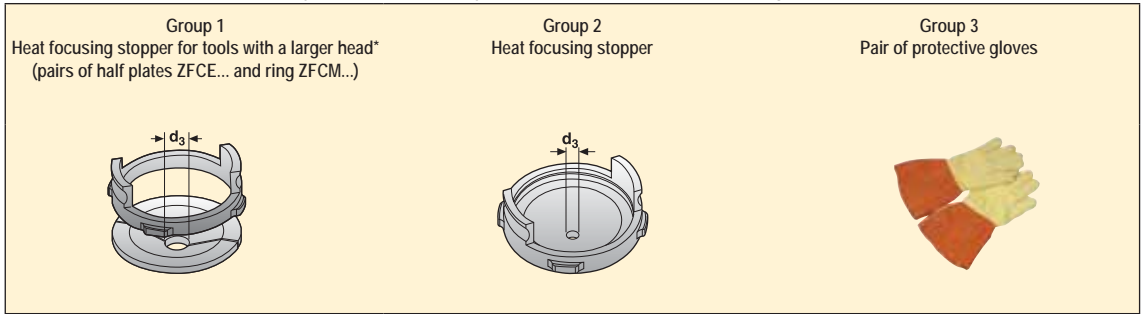
Accessories and spare parts for Easyshrink® 15 and Easyshrink® 20 Packs, induction heating



Group	Part No.	For Easyshrink		For tool shank Ø mm	d ₃ mm	 KG
		15	Packs 20			
1	ZFCE2521	■	■	Ø 3-6 mm	6,5	0,25
	ZFCE2522	■	■	Ø 8-14 mm	15	0,25
	ZFCE2523	■	■	Ø 16-18 mm	20	0,21
	ZFCE2524	■	■	Ø 20-25 mm	27	0,18
	ZFCE2525	■	■	Ø 32 mm	34	0,16
	ZFCM08IN000	■	■	-	-	0,04
2	ZFAT08C01	□	□	Ø 3-6 mm	6,5	0,29
	ZFAT08C02	□	□	Ø 8-14 mm	15	0,28
	ZFAT08C03	□	□	Ø 16-18 mm	20	0,24
	ZFAT08C04	□	□	Ø 20-25 mm	27	0,19
	ZFAT08C05	□	□	Ø 32 mm	34	0,17
3	ZFAG01	□	□	-	-	0,2

■ Accessories
 □ Spare parts
 * Maximum tool head that can pass through the inductor is 65 mm

Accessories and spare parts for Easyshrink® 15 and Easyshrink® 20 Packs, operating stations

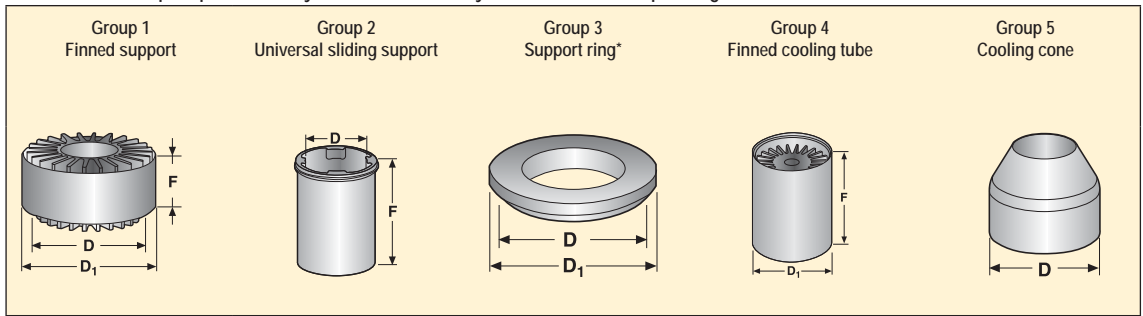

Group	Part No.	For Easyshrink		For Shrinkfit holder and tool shank sizes \varnothing mm	Dimensions in mm			 KG
		15	Packs 20		D	D ₁	F	
		1	ZFAD05H32		■	■	HSK-A32 / HSK-C32 / HSK-E32 / HSK-B40 / HSK-D40	
	ZFAD05H40	■	■	HSK-A40 / HSK-C40 / HSK-E40 / HSK-B50 / HSK-D50 / HSK-F50	90	114	50	0,7
	ZFAD05H50	■	■	HSK-A50 / HSK-C50 / HSK-E50 / HSK-B63 / HSK-D63 / HSK-F63	90	114	50	0,7
	ZFAD05H63	■	■	HSK-A63 / HSK-C63 / HSK-E63 / HSK-B80 / HSK-D80 / HSK-F80	90	114	50	0,7
	ZFAD05H10	■	■	HSK-A100 / HSK-C100 / HSK-B125 / HSK-D125	90	114	50	0,7
	ZFAD05S30	■	■	SA30	90	114	50	0,7
	ZFAD05S40	■	■	SA40	90	114	50	0,7
	ZFAD05S50	■	■	SA50	90	114	160	1,4
	ZFAD05C3	■	■	Seco-Capto C3	90	114	50	0,7
	ZFAD05C4	■	■	Seco-Capto C4	90	114	50	0,7
	ZFAD05C5	■	■	Seco-Capto C5	90	114	50	0,7
	ZFAD05C6	■	■	Seco-Capto C6	90	114	50	0,7
	ZFAD05C8	■	■	Seco-Capto C8	90	114	50	0,7
2	ZFAR08T	□	□	–	90	–	150	0,1
3	ZFAR07H32	■	■	HSK-A32 / HSK-C32 / HSK-E32 / Seco-Capto C3	90	99,5	–	0,2
	ZFAR07H40	■	■	HSK-A40 / HSK-C40 / HSK-E40 / HSK-B50 / HSK-D50 / HSK-F50 / Seco-Capto C4	90	99,5	–	0,2
	ZFAR07H50	■	■	HSK-A50 / HSK-C50 / HSK-E50 / HSK-B63 / HSK-D63 / HSK-F63	90	99,5	–	0,2
	ZFAR07H63	□	■	HSK-A63 / HSK-C63 / HSK-E63 / HSK-B80 / HSK-D80 / HSK-F80	90	99,5	–	0,2
	ZFAR07H10	■	■	HSK-A100 / HSK-C100	90	99,5	–	0,2
	ZFAR07C5	■	■	Seco-Capto C5	90	99,5	–	0,2
	ZFAR07C6	■	■	Seco-Capto C6	90	99,5	–	0,2
	ZFAR07C8	■	■	Seco-Capto C8	90	99,5	–	0,2
	ZFAR07S30	■	■	SA30	90	99,5	–	0,2
	ZFAR07S40	■	■	SA40	90	99,5	–	0,2
	ZFAR07S50	■	■	SA50	90	99,5	–	0,2
4	ZFAR02C306	■	■	5603 \varnothing 6 and 8 mm	–	114	180	1,55
	ZFAR02C310	■	■	5603 \varnothing 10 and 12 mm & 5600 \varnothing 6 and 8mm	–	114	180	1,55
	ZFAR02C314	■	■	5603 \varnothing 14 and 16 mm & 5600 \varnothing 10 and 14 mm	–	114	180	1,55
	ZFAR02C318	■	■	5603 \varnothing 18 and 20 mm & 5600 \varnothing 14 and 16 mm	–	114	180	1,55
	ZFAR02C325	■	■	5603 \varnothing 25 and 32 mm & 5600 \varnothing 18 and 20 mm	–	114	180	1,55
	ZFAR02C425	■	■	5800 \varnothing 25 and 32	–	–	–	1,55
5	ZFAR03C	□	□	–	110	–	–	0,1

■ Accessories

□ Spare parts

* Support ring: Both for operating and cooling on Easyshrink® 15. For cooling only on Easyshrink® 20 Packs.

Accessories and spare parts for Easyshrink® 15 and Easyshrink® 20 Packs, shrink depth setting

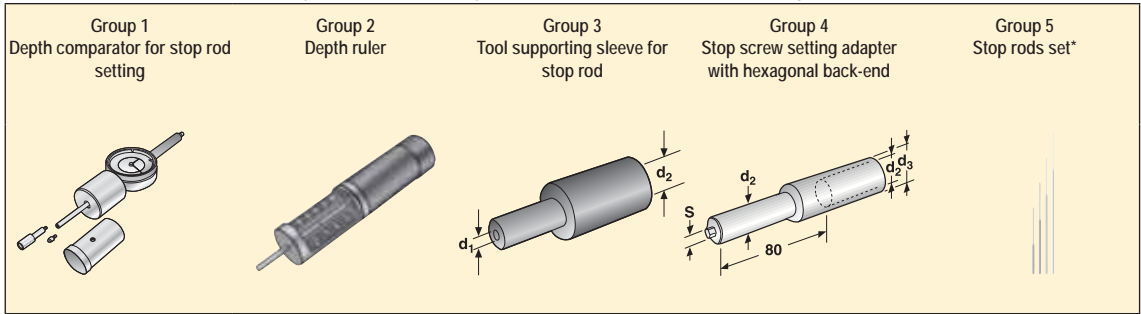

Group	Part No.	For Easyshrink		For stop rod dia d_1	S mm	Depth capacity	d_2 mm	d_3 mm	Thread fitting/ Ø Front	For length capacity	For Shrinkfit holder and tool shank sizes Ø mm	 KG
		15	Packs 20									
1	Z847031	■	■	-	-	25-75	-	-	-	-	6-32	1,0
2	ZFCM07IN282	■	■	-	-	10-35	-	-	-	-	3-5	0,6
	ZFCM07IN254	■	■	-	-	20-75	-	-	-	-	6-32	0,9
3	05RS580003		■	2,5	-	-	3	-	-	-	-	0,3
	05RS580004		■	2,5	-	-	4	-	-	-	-	0,3
	05RS580005		■	2,5	-	-	5	-	-	-	-	0,3
	05RS560006		■	4,2	-	-	6	-	-	-	-	0,1
	05RS560008		■	4,2	-	-	8	-	-	-	-	0,1
	05RS560010		■	4,2	-	-	10	-	-	-	-	0,1
	05RS560012		■	4,2	-	-	12	-	-	-	-	0,2
	05RS560014		■	4,2	-	-	14	-	-	-	-	0,2
	05RS560016		■	4,2	-	-	16	-	-	-	-	0,2
	05RS560018		■	4,2	-	-	18	-	-	-	-	0,2
	05RS560020		■	4,2	-	-	20	-	-	-	-	0,2
	05RS560025		■	4,2	-	-	25	-	-	-	-	0,4
05RS560032		■	4,2	-	-	32	-	-	-	-	0,3	
4	05R560006	■	■	-	2,5	-	6	12	-	-	-	0,3
	05R560008	■	■	-	3	-	8	16	-	-	-	0,3
	05R560010	■	■	-	4	-	10	20	-	-	-	0,3
	05R560012	■	■	-	5	-	12	25	-	-	-	0,4
	05R560014	■	■	-	5	-	14	25	-	-	-	0,4
	05R560016	■	■	-	6	-	16	25	-	-	-	0,4
	05R560018	■	■	-	6	-	18	30	-	-	-	0,4
	05R560020	■	■	-	8	-	20	30	-	-	-	0,4
	05R560025	■	■	-	8	-	25	40	-	-	-	0,4
	05R560032	■	■	-	8	-	32	40	-	-	-	0,4
5	ZFS07IN018		■	-	-	-	-	-	2,5	0-240	3-5	0,1
	ZFS07IN043		□	-	-	-	-	-	4,2	0-240	6-32	0,2

■ Accessories

□ Spare parts

* A storage rack and a stop rods set for sizes 6-32 mm are part of the delivery content of the Easyshrink® 20 Packs N°1, N°2 and N°3.

Accessories for the Pack Easyshrink® 20 N°3 and the Easyshrink® refrigerated cooling bells water cooler

Contact bush for cooling bells



Part No.	For Shrinkfit holder and tool shank sizes Ø mm	 KG
ZFAR10D006	5800 Ø 6 mm	0,6
ZFAR10D008	5800 Ø 8 mm	0,6
ZFAR10D010	5800 Ø 10 mm	0,6
ZFAR10D012	5800 Ø 12 mm	0,6
ZFAR10D014	5800 Ø 14 mm	0,6
ZFAR10D016	5800 Ø 16 mm	0,6
ZFAR10D018	5800 Ø 18 mm	0,6
ZFAR10D020	5800 Ø 20 mm	0,6
ZFAR10D025	5800 Ø 25 mm	0,6
ZFAR10D032	5800 Ø 32 mm	0,6
ZFAR10D103	5801 Ø 3 mm	0,6
ZFAR10D104	5801 Ø 4 mm	0,6
ZFAR10D105	5801 Ø 5 mm	0,6
ZFAR10D106	5801 Ø 6 mm	0,6
ZFAR10D108	5801 Ø 8 mm	0,6
ZFAR10D110	5801 Ø 10 mm	0,6
ZFAR10D112	5801 Ø 12 mm	0,6
ZFAR10D114	5801 Ø 14 mm	0,6
ZFAR10D116	5801 Ø 16 mm	0,6
ZFAR10D306	5603 Ø 6 mm and Ø 8 mm	0,6
ZFAR10D310	5603 Ø 10 and 12 mm & 5600 Ø 6 and 8 mm	0,6
ZFAR10D314	5603 Ø 14 and 16 mm & 5600 Ø 10 and 12 mm	0,6
ZFAR10D318	5603 Ø 18 and 20 mm & 5600 Ø 14 and 16 mm	0,6
ZFAR10D325	5603 Ø 25 and 32 mm & 5600 Ø 18 and 20 mm	0,6
ZFAR10D425	5600 Ø 25 and 32 mm	0,6
ZFAR10D303S	5603 extra short Ø 3, 4 and 5 mm	0,6
ZFAR10D306S	5603 extra short Ø 6 and 8 mm	0,6
ZFAR10D310S	5603 extra short Ø 10 and 12 mm & 5600 extra short Ø 6 and 8 mm	0,6
ZFAR10D314S	5603 extra short Ø 14 and 16 mm & 5600 extra short Ø 10 and 12 mm	0,6
ZFAR10D318S	5603 extra short Ø 18 and 20 mm & 5600 extra short Ø 14 and 16 mm	0,6
ZFAR10D325S	5603 extra short Ø 25 and 32 mm & 5600 extra short Ø 18 and 20 mm	0,6
ZFAR10D425S	5603 extra short Ø 25 mm and Ø 32 mm	0,6

Steels, ferritic and martensitic stainless steels

SMG	Description	Properties	Reference
P1	Free-cutting steels	$360 < R_m < 880$	11 SMn30 $R_m = 385 \text{ N/mm}^2$
P2	Low alloy ferritic steels, $C < 0.25\% \text{wt}$ Low alloy weldable general structural steels	$320 < R_m < 600$	S235JRG2 $R_m = 420 \text{ N/mm}^2$
P3	Ferritic & ferritic/pearlitic steels, $C < 0.25\% \text{wt}$ Weldable general structural steels Case hardening steels	$430 < R_m < 610$	16 MnCr 5 $R_m = 550 \text{ N/mm}^2$
P4	Low alloy general structural steels, $0.25\% < C < 0.67\% \text{wt}$ Low alloy Quench & Temper steels	$520 < R_m < 1200$	C 45E $R_m = 660 \text{ N/mm}^2$
P5	Structural steels, $0.25\% < C < 0.67\% \text{wt}$ Quench & Temper steels	$550 < R_m < 1200$	42 CrMo 4 $R_m = 700 \text{ N/mm}^2$
P6	Low alloy through hardening steels, $C > 0.67\% \text{wt}$ Low alloy spring and bearing steels	$520 < R_m < 1200$	C 100S $R_m = 600 \text{ N/mm}^2$
P7	Through hardening steels, $C > 0.67\% \text{wt}$ Spring and bearing steels	$600 < R_m < 1200$	100 Cr 6 $R_m = 650 \text{ N/mm}^2$
P8	Tool steels High Speed Steels (HSS)	$600 < R_m < 1200$	X 40 CrMoV 5 1 $R_m = 700 \text{ N/mm}^2$
P11	Ferritic & martensitic stainless steels	$415 < R_m < 1200$	X 20 Cr 13 $R_m = 675 \text{ N/mm}^2$

Free-cutting, austenitic and duplex stainless steels

SMG	Description	Properties	Reference
M1	Free-cutting austenitic stainless steels		X 10 CrNiS 18 9
M2	Low alloy austenitic stainless steels		X 5 CrNi 18 9
M3	Medium alloy austenitic stainless steels		X 2 CrNiMo 18 14 3
M4	High alloy austenitic and duplex stainless steels		X 2 CrNiMoN 22 5 3
M5	Difficult high alloy austenitic and duplex stainless steels		X 2 CrNiMoN 25 7 4

Cast irons

SMG	Description	Properties	Reference
K1	Grey cast irons (GCI)		EN-GJL-250
K2	Compacted graphite irons (CGI)		EN-GJV-400
K3	Malleable cast irons (MCI)		EN-GJMB-550-4
K4	Nodular cast irons (SGI)		EN-GJS-500-7
K5	Austempered ductile irons (ADI)		EN-GJS-1000-5
K6	Austenitic lamellar cast irons		EN-GJLA-XNiCuCr15-6-2
K7	Austenitic nodular cast irons		EN-GJSA-XNiMn23-4

Non-ferrous metals

SMG	Description	Properties	Reference
N1	Aluminum alloys, Si < 9%		AW-7075
N2	Aluminum alloys, 9% < Si < 16%		AC-44200 Si = 12%
N3	Aluminum alloys, Si > 16%		AlSi17Cu5
N11	Copper alloys		CW614N

Superalloys and titanium

SMG	Description	Properties	Reference
S1	Iron based superalloys		Discalloy
S2	Cobalt based superalloys		Stellite 21
S3	Nickel based superalloys		Inconel 718
S11	Titanium, low alloyed, (α)		Ti
S12	Titanium, medium alloyed, ($\alpha+\beta$)		TiAl6V4
S13	Titanium, high alloyed, (near β and β)		Ti10V2Fe3Al

Hard materials

SMG	Description	Properties	Reference
H3	Case hardened steels	58 < HRC < 62	16 MnCr 5 60 HRC
H5	Quenched & Tempered steels	38 < HRC < 56	42 CrMo 4 50 HRC
H7	Quenched & Tempered steels Bearing steels	56 < HRC < 64	100 Cr 6 60 HRC
H8	Tool steels High Speed Steels	38 < HRC < 64	X 40 CrMoV 5 1 50 HRC
H11	Martensitic stainless steels	38 < HRC < 50	X 20 Cr 13 45 HRC
H12	Precipitation hardened stainless steels	33 < HRC < 50	X 5 CrNiCuNb 16 4 35 HRC
H21	Manganese steels	23 < HRC < 64	X 120 Mn 12 50 HRC
H31	White cast irons	50 < HRC < 64	EN-GJN-HV600(XCr11) 55 HRC

Other difficult materials

SMG	Description	Properties	Reference
PM1	Low alloy PM materials		F-0008 Fe-0.7C
PM2	Medium alloy PM materials		FLC-4608 Fe2Cu1.8Ni0.5Mo0.2Mn0.8C
PM3	High alloy PM materials Exhaust valve seat materials		
HF1	Hard facing alloys Welded or plasma deposited iron based alloys		
HF2	Hard facing alloys Welded or plasma deposited cobalt and nickel based alloys		
CC1	Sintered tungsten carbide		G50

Plastics and Composites

SMG	Description	Properties	Reference
TS1	Thermosetting polymers		Urea formaldehyde (UF)
TS2	Thermosetting Carbon fiber composites		T300 T700 T800 HTA-S IMA - Epoxy (M21)...
TS3	Thermosetting Glass fiber composites		Epoxy - HX.(42..)/E glass (7781...)...
TS4	Thermosetting Aramide fibre composites		Kevlar 49
TP1	Thermoplastic polymers		Polycarbonate (PC)
TP2	Thermoplastic Carbon fiber composites		PPS/PEEK - T300..
TP3	Thermoplastic Glass fiber composites		PPS/PEEK - E glass or A glass...
TP4	Thermoplastic Aramide fibre composites		

Graphite

SMG	Description	Properties	Reference
GR1	Graphite		R 8500

SMG

SMG	EN	EN-Nr	W.-Nr	DIN	AFNOR	BS	UNI	JIS	SS	UNS	
P1	11 SMn30	1.0715	1.0715	9 SMn 28	S 250	230 M 07	CF 9 SMn 28	SUM 22	1912	G12130	
	11 SMnPb30	1.0718	1.0718	9 SMnPb 28	S 250 Pb		CF 9 SMnPb 28	SUM 22 L	1914	G12134	
	10 S 20	1.0721	1.0721	10 S 20	10 F 1	210 M 15	CF 10 S 20				
				1.0722	10 SPb 20	10 PbF 2		CF 10 SPb 20			
	15 SMn13	1.0725	1.0723	15 S 20		210 A 15		SUM 32	1922		
	35 S20	1.0726	1.0726	35 S 20	35 MF 4	212 M 36			1957	G11400	
	46 S20	1.0727	1.0727	46 S 20	45 MF 4	212 M 44			1973	G11460	
	11 SMn37	1.0736	1.0736	9 SMn 36	S 300	240 M 07	CF 9 SMn 36			G12150	
	11 SMnPb 37	1.0737	1.0737	9 SMnPb 36	S 300 Pb		CF 9 SMnPb 36		1926	G12144	
	S235JR	1.0037	1.0037	St 37-2	E 24-2		Fe 360 B	STKM 12 C	1311		
P2	S235JRG2	1.0038	1.0116	St 37-3	E 24-3, E 24-4	4360-40 C	Fe 360 D FF		1312, 1313		
	S275J2G3	1.0144	1.0144	St 44-3 N	E 28-3, E 28-4	4360-43 C	Fe 430 D FF	SM 41 C	1412, 1414		
	C 10	1.0301	1.0301	C 10	AF 34 C 10, XC 10	045 M 10	C 10	S 10 C		G10100	
			1.0401	C 15	AF3 7 C 12, XC 18	080 M 15	C 15, C 16		1350	G10170	
	C22+N	1.0402	1.0402	C 22	C 22	050 A 20	C 20, C 21		1450	G10200	
	S355JR	1.0570	1.0570	St 52-3	E 36-3, E 36-4	4360-50 C	Fe 510 B	SM 50 YA	2172, 2132		
	C 15R	1.1141	1.1141	Ck 15	XC 15, XC 18	080 M 15	C 15, C 16	S 15 C, S 15 CK	1370	G10170	
			1.1158	Ck 25	XC 25	060 A 25	C 25	S 25 C		G10250	
			1.2162	21 MnCr 5	20 NC 5			SCR 420 H			
	16 Mo 3	1.5415	1.5415	15 Mo 3	15 D 3	1501-240	16 Mo 3		2912		
P3			1.5423	16 Mo 5		1503-245-420	16 Mo 5	SB 450 M		G45200	
	14 NiCr 14	1.5752	1.5752	14 NiCr 14	12 NC 15	655 M 13		SNC 815 (H)		G33106	
			1.5919	15 CrNi 6	16 NC 6	S 107	16 CrNi 4				
	18 NiCrMo 7 6	1.6587	1.6587	18 CrNiMo 7 6	18 NCD 6	820 A 16	18 NiCrMo 7				
	16 MnCr 5	1.7131	1.7131	16 MnCr 5	16 MC 5	527 M 17	16 MnCr 5	SCR 415	2511	G51170	
	16 MnCrS 5	1.7139	1.7139	16 MnCrS 5							
	20 MnCr 5	1.7147	1.7147	20 MnCr 5	20 MC 5		20 MnCr 5	SMnC 420 (H)		G51200	
	20 MnCrS 5	1.7149	1.7149	20 MnCrS 5	20 MnCrS 5			SMnC 21 H			
	13 CrMo 4 5	1.7335	1.7335	13 CrMo 4 4	15 CD 3,5	1501-620 Gr. 27	14 CrMo 4 5		2216		
			1.7337	16 CrMo 4 4	15 CD 4,5	1501-620 Gr. 27	14 CrMo 4 5		2216		
10 CrMo 9 10	1.7380	1.7380	10 CrMo 9 10	10 CD 9,10	1501-622 Gr. 31	12 CrMo 9 10		2218	J21890		
P4	C35+N		1.0501	C 35	AF 55 C 35	060 A 35	C 35		1550	G10350	
	E 335	1.0503	1.0503	C 45	AF 65 C 45	80 M 46	C 45	S 45 C	1650	G10430	
	C40+N		1.0511	C 40	AF 60 C 40	080 M 40	C 40	S 40 C			
	E 360	1.0070	1.0535	St 70-2	A 70-2		Fe 690		1655		
	C60+N	1.0601	1.0601	C 60	CC 55	080 A 62	C 60			G10600	
			1.1157	40 Mn 4	35 M 5	150 M 36				G10390	
	G 28 Mn6	1.1165	1.1165	30 Mn 5		120 M 36		SMn 1 H, SCMn 2		G13300	
	G 28 Mn6+QT	1.1165	1.1167	36 Mn 5	40 M 5	150 M 36		SMn 438 (H), SCMn 3	2120	G13350	
	C 35E	1.1181	1.1181	Ck 35	XC 38 H1	080 M 36	C 35	S 35 C	1572	G10340	
	C 45E	1.1191	1.1191	Ck 45	XC 42	080 M 46	C 45	S 45 C	1672	G10420	
C 60E	1.1221	1.1221	Ck 60	XC 60	080 A 62	C 60	S 58 C	1665, 1678	G10640		
P5			1.1740	C 60 W	Y3 55			SK 7			
	55 SiCr7	1.7100	1.0904	55 Si 7	55 S 7	250 A 53	55 Si 8		2085, 2090		
	42 CrMo 4	1.7225	1.1201	42 CrMo 4	42 CD 4	708 M 40	42 CrMo 4	SCM 440 (H)	2244	G41400	
	42 CrMo 4	1.7225	1.1201	42 CrMo 4	42 CD 4	708 M 40	42 CrMo 4	SCM 440 (H)	2244	G41400	
			1.2330	35 CrMo 4	34 CD 4	708 A 37	35 CrMo 4		2234	T51620	
			1.2542	45 WCrV 7			BS 1	45 WCrV 8 KU	2710	T41901	
		1.2714	1.2714	56 NiCrMoV 7			BH 224-5	56 NiCrMoV7-KU		T61206	
			1.5121	46 MnSi 4							
			1.5710	36 NiCr 6	35 NC 6	640 A 35			SNC 236		
			1.5736	36 NiCr 10	35 NC 11			35 NiCr 9	SNC 631 (H)		
P6	36CrNiMo4+TA		1.6511	36 CrNiMo 4	40 NCD 3	816 M 40	38 NiCrMo 4 (KB)			G98400	
	34 CrNiMo 6	1.6582	1.6582	34 CrNiMo 6	35 NCD 6	817 M 40	35 NiCrMo 6 (KW)	SNCM 447	2541		
	34 Cr 4	1.7033	1.7033	34 Cr 4	32 C 4	530 A 32	34 Cr 4 (KB)	Scr 430 (H)		G51320	
	41 Cr 4	1.7035	1.7035	41 Cr 4	42 C 4	530 M 40	41 Cr 4	Scr 440 (H)		G51400	
	25 CrMo 4	1.7218	1.7218	25 CrMo 4	25 CD 4 S	708 M 25	25 CrMo 4 (KB)	SCM 425	2225	G41300	
			1.7361	32 CrMo 12	30 CD 12	722 M 24	32 CrMo 12		2240		
	50 CrV 4	1.8159	1.8159	50 CrV 4	50 CV 4	735 A 50	51 CrV 4	SUP 10	2230	H61500	
	41 CrAlMo 7 10	1.8509	1.8509	41 CrAlMo 7	40 CAD 6.12	905 M 39	41 CrAlMo 7	SACM 645	2940	K24065	
	C 67S	1.1231	1.1231	Ck 67	XC 68	060 A 67	C 70		1770	G10700	
	C 100S	1.1274	1.1274	Ck 101		060 A 96		SUP 4	1870	G10950	
P6	C 105U	1.1545	1.1545	C 105 W1	Y1 105		C 100 KU		1880		
			1.1645	C 105 W2	Y1 105		C 100 KU	SK 3			
			1.1663	C 125 W	Y2 120		C 120 KU	SK 2			

SMG

U.N.E./I.H.A.	AISI / ASTM	GOST	Misc. Brands	Condition	Structure
	1213			Annealed	
	12 L 13			Annealed	
	1108			Annealed	
	11 L 08			Annealed	
				Annealed	
	1140	40		Annealed	
	1146			Annealed	
	1215			Annealed	
	12 L 14			Annealed	
		16D		Annealed	
	A 573 Gr. 58	18kp		Annealed	
	A 573 Gr. 70	S114kP		Annealed	
	1010	10		Annealed	
F.1110	1015	15		Annealed	
	1023	20		Annealed	
		17G1S		Annealed	
F.1511	1015	15		Annealed	
F.1120	1025	25		Annealed	
				Annealed	
	A 204 Gr. A			Annealed	
	4520			Annealed	
	3310, 9314	20X2H4A		Annealed	
	4320			Annealed	
				Annealed	
F.1516	5115	12KHN2		Annealed	
		18HG		Annealed	
	5120	20KH		Annealed	
	5120 H	20KH		Annealed	
	A 182-F11, F12	12KHM		Annealed	
	A 387 Gr. 12 Cl. 2			Annealed	
F.155	A 182-F22	12KH8		Annealed	
F.1130	1035	35		Annealed	
F.5110	1045	45		Annealed	
	1040	40		Annealed	
F.1150	1055	55		Annealed	
	1060	60		Annealed	
	1039	40G		Annealed	
	1330	30G2		Annealed	
F.411	1335	35G2		Annealed	
F.1135	1035	35		Annealed	
F.1140	1045	45		Annealed	
F.1150	1064	60		Annealed	
	1060	60		Annealed	
F.144	9255	55S2		Annealed	
F.1252	4142, 4140	38HM		Annealed	
F.1252	4142, 4140	38HM		Quenched & Tempered	
F.1250	4135	35KHM		Annealed	
F.5241	S1	5KHV2S		Annealed	
	L6	5KHNV		Annealed	
	5045			Annealed	
	3135			Quenched & Tempered	
	3435			Annealed	
	9840			Quenched & Tempered	
F.1280	4340	38H2N2MA		Annealed	
	5132	35KH		Quenched & Tempered	
	5140	40H		Quenched & Tempered	
F.1251	4130	20KHM		Quenched & Tempered	
				Quenched & Tempered	
F.143	6150	50KHFA		Quenched & Tempered	
F.1740	A 355 Cl. A			Annealed	
F.5103	1070	70		Annealed	
F.5117	1095			Annealed	
F.5118	W1	U10A		Annealed	
		U10		Annealed	
	W1	U13		Annealed	

SMG

SMG	EN	EN-Nr	W.-Nr	DIN	AFNOR	BS	UNI	JIS	SS	UNS
P7	107 CrV 3	1.2210	1.2210	115 CrV 3	100 C 3		107 CrV 3 KU			T61202
			1.2510	100 MnCrW 4	90 MWCV 5	BO 1	95 MnWCr 5 KU	SKS 3	2140	T31501
	90 MnCrV 8	1.2842	1.2842	90 MnCrV 8	90 MV 8	BO 2	90 MnVCr 8 KU			T31502
	100 Cr 6	1.3505	1.3505	100 Cr 6	100 C 6	534 A 99	100 Cr 6	SUJ 2	2258	G51986
P8	X 210 Cr 12	1.2080	1.2080	X 210 Cr 12	Z 200 C 12	BD 3	X 210 Cr 13 KU	SKD 1		T30403
			1.2343	X 38 CrMoV 5 1	Z 38 CDV 5	BH 11	X 37 CrMoV 5 1 KU	SKD 6		T20811
	X 40 CrMoV 5 1	1.2344	1.2344	X 40 CrMoV 5 1	Z 40 CDV 5	BH 13	X 40 CrMo 5 1 1 KU	SKD 61	2242	T20813
	X 100 CrMoV 5	1.2363	1.2363	X 100 CrMoV 5 1	Z 100 CDV 5	BA 2	X 100 CrMoV 5 1 KU	SKD 12	2260	T30102
			1.2365	X 32 CrMoV 3 3	32 DCV 28	BH 10	30 CrMoV 12 27 KU	SKD 7		T20810
			1.2436	X 210 CrW 12			X 215 CrW 12 1 KU	SKD 2	2312	
			1.2601	X 165 CrMoV 12			X 165 CrMoV 12 KU		2310	
			1.2713	55 NiCrMoV 6	55 NCDV 7			SKT 4		T61206
	HS 6-5-2-5	1.3243	1.3243	S 6-5-2-5	Z 85 WDCKV 06-05-04-02		HS 6-5-2-5	SKH 55	2723	
	HS 2-10-1-8	1.3247	1.3247	S 2-10-1-8	Z 110 DKCWV 09-08-04	BM 42	HS 2-9-1-8	SKH 51		T11342
	HS 18-1-2-5	1.3255	1.3255	S 18-1-2-5	Z 80 WKCIV 18-05-04-01	BT 4	HS 18-1-1-5	SKH 3		T12004
	HS 6-5-2	1.3343	1.3343	S 6-5-2	Z 85 WDCV 06-05-04-02	BM 2	HS 6-5-2	SKH 9, SKH 51	2722	T11302
HS 2-9-2	1.3348	1.3348	S 2-9-2	Z 100 DCWV 09-04-02-02		HS 2-9-2	SKH 58	2782	T11307	
HS 18-0-1	1.3355	1.3355	S 18-0-1	Z 80 WCV 18-04-01	BT 1	HS 18-0-1	SKH 2		T12001	
X 6 Cr 13	1.4000	1.4000	X 6 Cr 13	Z 6 C 12	403 S 17	X 6 Cr 13	SUS 403	2301	S41008	
X 12 Cr 13	1.4006	1.4006	X 10 Cr 13	Z 10 C 13	410 S 21	X 12 Cr 13	SUS 410	2302	S41000	
X 6 Cr 17	1.4016	1.4016	X 6 Cr 17	Z 8 C 17	430 S 15	X 8 Cr 17	SUS 430	2320	S43000	
X 20 Cr 13	1.4021	1.4021	X 20 Cr 13	Z 20 C 13	420 S 37	X 20 Cr 13	SUS 420 J 1	2303	S42000	
X 39 Cr 13	1.4031	1.4031	X 40 Cr 13	Z 40 C 14	420 S 45	X 40 Cr 14	SUS 420	2304	S40280	
X 70 CrMo 15	1.4109	1.4109	X 65 CrMo 14	Z 70 D 14			SUS 440 A		S44002	
X 90 CrMoV 18	1.4112	1.4112	X 90 CrMoV 18	Z 2 CND 18 05	409 S 19	X CrTi 12	SUS 440 B	2327	S44003	
X 105 CrMo 17	1.4125	1.4125	X 105 CrMo 17	Z 100 CD 17		X 105 CrMo 17	SUS 440 C		S44004	
X 3 CrNiMo 13 3	1.4313	1.4313	X 5 CrNi 13 4	Z 5 CN 13.4	425 C 11	X 6 CrNi 13 04	SCS 5	2385	J91540	
X 18 CrN 28	1.4749	1.4749	X 18 CrN 28	Z 18 C 25					2322	S44600
M1	X 10 CrNiS 18 9	1.4305	1.4305	X 10 CrNiS 18 9	Z 10 CNF 18.09	303 S 31	X 10 CrNi 18 09	SUS 303	2346	S30300
	X 12 CrNi 18 8	1.4300	1.4300	X 12 CrNi 18 8	Z 12 CN 18	302 S 25		SUS 302	2331	S30200
	X 5 CrNi 18 9	1.4301	1.4301	X 6 CrNi 18 10	Z 6 CN 18.09	304 S 31	X 5 CrNi 18 11	SUS 304	2333	S30400
M2	X 2 CrNi 19 11	1.4306	1.4306	X 2 CrNi 19 11	Z 2 CN 18.10	304 S 12	X 3 Cr Ni 18 11	SUS 304 L	2352	S30403
	X 9 CrNi 18 8	1.4310	1.4310	X 12 CrNi 17 7	Z 12 CN 17.07	301 S 21	X 12 CrNi 17 07	SUS 301	(2331)	S30100
	X 5 CrNiMo 17 12 2	1.4401	1.4401	X 5 CrNiMo 17 12 2	Z 3 CND 17.11.1	316 S 31	X 5 CrNiMo 17 12	SUS 316	2347	S31600
X 6 CrNiNb 18 10	1.4550	1.4550	X 6 CrNiNb 18 10	Z 6 CENNb 18.10	347 S 31	X 6 CrNiNb 18 11	SUS 347	2338	S34700	
M3	X 2 CrNiN 18 10	1.4311	1.4311	X 2 CrNiN 19 11	Z 2 CN 18_10 Az	304 S 62	X 2 CrNiN 18 11	SUS 304 LN	2371	S30453
	X 12 CrNi 25 21	1.4335	1.4335	X 12 CrNi 25 21	Z 12 CN 25.20	310 S 24	X 6 CrNi 26 20	SUH 310, SUS 310 S	2361	S31008
	X 2 CrNiMoN 17 13 3	1.4429	1.4429	X 2 CrNiMoN 17 13 3	Z 2 CND 17.13 Az	316 S 62	X 2 CrNiMoN 17 13 3	SUS 316 LN	2375	S31653
	X 2 CrNiMo 18 14 3	1.4435	1.4435	X 2 CrNiMo 18 14 3	Z 2 CND 17.13	316 S 12	X 2 CrNiMo 17 13 2	SCS 16, SUS 316 L	2353	S31603
	X 3 CrNiMo 18 12 3	1.4466	1.4466	X 5 CrNi 18 15		317 S 16	X 5 CrNi 18 15	SUS 317	2366	S31700
	X 9 CrNiSiN 21 11 2	1.4835	1.4893	X 9 CrNiSiN 21 11 2		310 S 31			2368	S30815
M4	X 2 CrNiMoSi 19 5	1.4424	1.4417	X 2 CrNiMoSi 19 5	Z 2 CND 18.05.03				2376	S31500
	X 3 CrNiMo 27 5 2	1.4460	1.4460	X 4 CrNiMo 27 5 2	Z 3 CND 25.7 Az		X 3 CrNiMo 27 5 2	SUS 329 J 1	2324	S32900
	X 2 CrNiMoN 22 5 3	1.4462	1.4462	X 2 CrNiMoN 22 5	Z 2 CND 22.05 Az	332 S 15	X 2 CrNiMoN 22 5		2377	S31803
	X 2 NiCrMoCu 25 20 5	1.4539	1.4539	X 2 NiCrMoCu 25 20 5	Z 2 NCDU 25 20	904 S 13			2562	N08904
M5	X 2 CrNiMoN 25 7 4	1.4410	1.4410	X 2 CrNiMoN 25 7 4	Z 3 CND 25.07 Az		X 2 CrNiMoN 25 7 4		2328	S32750
	X 1 CrNiMoN 20 18 7	1.4547	1.4529	X 1 CrNiMoN 20 18 7	Z 1 CNDU 20.18.05 Az		X 1 CrNiMoN 20 18 7		2778	S31254
	X 6 NiCrTiMoV 25 15	1.4534	1.4534	X 3 CrNiMoAl 13 8 2						S13800
		1.4540	1.4540	X 4 CrNiCuNb 16 4	Z 4 CNUNb 16.4 M					S15500
	X 3 CrNiMoAl 13 8 2	1.4568	1.4568	X 7 CrNiAl 17 7	Z 9 CAN 17.7	301 S 81	X 7 CrNiAl 17 7	SUS 631	2388	S17700
	X 1 CrNiMoN 25 22 8	1.4652	1.4652	X 2 CrNiMoN 25 22 7						S32654
X 10 NiCrAlTi 32 20	1.4876	1.4876	X 10 NiCrAlTi 32 20	Z 10 NC 32.21			NCF 800		N08800	
X 5 CrNiCuNb 16 4	1.4980	1.4943	X 4 NiCrTi 25 15	Z 6 NCTDV 25.15	HR 51		SUH 660	2570	S66286	

SMG

U.N.E./I.H.A.	AISI / ASTM	GOST	Misc. Brands	Condition	Structure
F.520L	L2	11KHF		Annealed	
F.5220	O1	9KHVG		Annealed	
	O2	9G2F		Annealed	
F.5230	52100	SHKH15		Annealed	
F.5212	D3	KH12		Annealed	
	H11	4KH5MFS		Annealed	
F.5318	H13	4KH5MF1S		Annealed	
F.5227	A2	9KH5VF		Annealed	
	H10	3KH3M3F		Annealed	
F.5213		KH12		Annealed	
		KH12MF		Annealed	
F.520.S	L6	5KHNM		Annealed	
F.5613	M35	R6M5K5		Annealed	
	M42	R2AM9K5		Annealed	
	T4	R18K5F2		Annealed	
F.5603	M2	R6M5		Annealed	
	M7			Annealed	
	T1	R18		Annealed	
	403	08KH13		Annealed	Ferrite
F.3401	410, CA-15	12KH13, 08KH13		Annealed	Martensite
F.3113	430	12KH17		Annealed	Ferrite
F.5261	420	20KH13		Annealed	Martensite
F.3404	420	40KH13		Annealed	Martensite
	440 A			Annealed	Martensite
	440 B	95KH18		Annealed	Martensite
	440 C	95KH18		Annealed	Martensite
			F6NM	Annealed	Martensite
	446	15KH28		Annealed	Ferrite
F.3508	303	12KH19N9		Annealed	Austenite
	302	12KH18N9		Annealed	Austenite
F.3504	304, 304 H	08KH18N10		Annealed	Austenite
F.3504	304 L	03KH18N11		Annealed	Austenite
F.3517	301	07KH16N6		Annealed	Austenite
F.3534	316	08KH17H13M2T		Annealed	Austenite
F.3524	347	08KH18N12B		Annealed	Austenite
F.3541	304 LN	03KH18N11		Annealed	Austenite
	310 S	12KH25N20		Annealed	Austenite
	316 LN	03KH16N15M3		Annealed	Austenite
F.3533	316 L	03KH17N14M3		Annealed	Austenite
	317	08KH17H15M3T		Annealed	Austenite
			253 MA	Annealed	Austenite
			3RE60	Annealed	Duplex
	329			Annealed	Duplex
	329 LN		SAF 2205	Annealed	Duplex
	904L			Annealed	Super austenite
	F 53		SAF 2507	Annealed	Super duplex
			254 SMO	Annealed	Super austenite
	XM-13		PH13-8Mo	Solution treated	Austenite
	XM-12		15-5-PH	Solution treated	Martensite
	AMS 5528	09KH17N7YU1	17-7-PH	Solution treated	Austenite/ferrite
			654 SMO	Annealed	Super austenite
			Alloy 800	Annealed	Austenite
	660		A286	Solution treated	Austenite

SMG

SMG	EN	EN-Nr	W-Nr	DIN	AFNOR	BS	UNI	JIS	SS	UNS	
K1	EN-GJL-150	0.6150	0.6150	GG-15	F1 15 D	Grade 150	G15	FC 150	01 15-00	F11601	
	EN-GJL-200	0.6200	0.6200	GG-20	F1 20 D	Grade 220	G20	FC 200	01 20-00	F12101	
	EN-GJL-215			GG-220 HB					02 19		
	EN-GJL-250	0.6250	0.6250	GG-25	F1 25 D	Grade 260	G25	FC 250	01 25-00	F12401	
	EN-GJL-300	0.6300	0.6300	GG-30	F1 30 D	Grade 300	G30	FC 300	01 30-00	F13101	
EN-GJL-350	0.6350	0.6350	GG-35	F1 35 D	Grade 350	G35	FC 350	01 35-00	F13502		
K2	EN-GJV-300			GJV-300							
	EN-GJV-350			GJV-350							
	EN-GJV-400			GJV-400							
	EN-GJV-450			GJV-450							
EN-GJV-500			GJV-500								
K3	EN-GJMB-550-4	0.8155		GTS-55-04	P 540/5	P 540/5	P 55-04	PCMP55-04	08 54-00	F24130	
K4	EN-GJS-350-22	0.7033	0.7033	GGG-35.3	FGS 370-17	Grade 350/22		FCD 350-22L	07 17-15		
	EN-GJS-400-15	0.7040	0.7040	GGG-40	FGS 400-12	Grade 420/12	GS 400-12	FCD 400-18L	07 17-02	F32800	
	EN-GJS-400-18	0.7043	0.7043	GGG-40.3	FGS 370-17	Grade 370/17	GSO 42/17		07 17-12	F32800	
	EN-GJS-500-7	0.7050	0.7050	GGG-50	FGS 500-7	Grade 500/7	GS 500-7	FCD 500-7	07 27-02	F33800	
	EN-GJS-600-3	0.7060	0.7060	GGG-60	FGS 600-3	Grade 600/3	GS 600-3	FCD 600-3	07 32-03	F34100	
EN-GJS-700-2	0.7070	0.7070	GGG-70	FGS 700-2	Grade 700/2	GS 700-2	FCD 700-2	07 37-01	F34800		
K5	-									ADI grade 5	
	EN-GJS-1000-5			GJS-1000-5						ADI grade 2	
	EN-GJS-1200-2			GJS-1200-2						ADI grade 3	
	EN-GJS-1400-1			GJS-1400-1						ADI grade 4	
	EN-GJS-800-8			GJS-800-8						ADI grade 1	
K6	EN-GJLA-XNiCr 20-2	0.6660	0.6660	GGL-NiCr 20 2	FGL Ni20 Cr2	Grade F2			05 23-00	F41002	
	EN-GJLA-XNiCr 30-3	0.6676	0.6676	GGL-NiCr 30 3	FGL Ni30 Cr3	Grade F3				F41004	
	EN-GJLA-XNiCuCr15-6-2	0.6655	0.6655	GGL-NiCuCr 15 6 2	FGL Ni15 Cu6 Cr2	Grade F1				F41000	
K7	EN-GJSA-XNi35	0.7683	0.7683	GGG-Ni 35	FGS Ni35					F43006	
	EN-GJSA-XNiCr20-2	0.7660	0.7660	GGG-NiCr 20 2	FGS Ni20 Cr2	Grade S2				F43000	
	EN-GJSA-XNiCr30-3	0.7676	0.7676	GGG-NiCr 30 3	FGS Ni30 Cr3	Grade S3				F43003	
	EN-GJSA-XNiMn13-7	0.7652	0.7652	GGG-NiMn 13 7	FGS Ni13 Mn7	Grade S6			07 72-00	-	
	EN-GJSA-XNiMn23-4	0.7673	0.7673	GGG-NiMn 23 4	FGS Ni23 Mn4	Grade S2M				F43010	
N1	AW-1050A	Al99.5	3.0255	Al99.5	A-5/1050A	1B		(A1050)	4007	AA1050A	
	AW-3103	AlMn1	3.0515	AlMn1		N3			4054	AA3103	
	AW-3003	AlMn1Cu	3.0517	AlMn1Cu	A-M1/3003			A3003		AA3003	
	AW-2014	AlCuSiMn	3.1255	AlCuSiMn	A-U4SG/2014	H15			4338	AA2014	
	AW-2011	AlCuBiPb	3.1655	AlCuBiPb	A-USPbBi/2011	FC1		A2011	4355	AA2011	
	AC-46200	AlSi8Cu3(Si)	3.2161	G-AlSi8Cu3					4251	A13800	
	AC-42000		3.2341	G-AlSi5Mg	A-S7G	LM25	3599	AC 4C	4244		
	AW-6060	AlMgSi0.5	3.3206	AlMgSi0.5	A-GS/6060	(H9)			4103	AA6060	
	AW-6063	AlMgSi0.7	3.3210	AlMgSi0.7	A-GSUC/6061	(H10)		(A6063)	4104,4107	AA6005	
	AW-5005	AlMg1	3.3315	AlMg1	A-G0.6	N41			4106	AA5005	
	AW-7020	AlZn4.5Mg1	3.4335	AlZn4.5Mg1	A-Z5G/7020	H17			4425	AA7020	
	AW-7075		3.4365	AlZnMgCu1.5	A-Z5GU/7075	2L95/2L96		A7075		AA7075	
	MN65120	MgSe3Zn2Zr1	3.5103	G-MgSe3Zn2Zr1	ZRE1	MAG6-TE					M12330
	MG-P-63	MgAl6Zn	3.5612	G-MgAl6Zn	G-A6-21	MAG-E-121					M11600
	MG-P-61	MgAl8Zn	3.5812	G-MgAl8Zn	(G-A7-21)						
N2	AW-6082	AlMgSi1	3.2315	AlMgSi1	A-SGM0.7/6082	H30			4212	AA6082	
	AC-43400	AlSi10Mg(Fe)	3.2381	G-AlSi10Mg	A-S10G	LM9			4253	A13600	
	AC-44200	AlSi12	3.2382	GD-AlSi12							
N3	AlSi17Cu5							ADC14			
N11	CC331G		2.0940.01	CuAl10Fe	CuAl10Fe	AB1			5710	C95200	
	CC333G		2.0975.01	CuAl10Ni	CuAl10Ni5Fe5	AB2			5716	C95500	
			2.0872	CuNi10Fe1Mn	CuNi10Fe1Mn	CN102			5667	C70600	
				CuNi10Zn45							
	CW408J		2.0790	CuNi18Zn19Pb	CuNi18Zn19Pb1					C76300	
	CW352H		2.1176	CuPb10Sn	CuSn10Pb10	LB2			5640	C93700	
	CC480K		2.1050.01	CuSn10	CuSn10	CT1			5443	C90700	
			2.1087	CuSn10Zn					5458	C90500	
	CW452K	CuSn6	2.1020	CuSn6	CuSn6	PB103		C5191	5428	C51900	
	CW502L	CuZn15	2.0240	CuZn15	CuZn15	CZ102		C2300	5112	C23000	
	CW706R	CuZn28Sn1	2.0470	CuZn28Sn1	CuZn29Sn1				5220	C44300	
	CW508L	CuZn37	2.0321	CuZn37	CuZn37	CZ108			5150	C27200	
	CW717R	CuZn38Sn1	2.0530	CuZn38Sn1						C46400	
	CW614N	CuZn39Pb3	2.0401	CuZn39Pb3	CuZn39Pb3	CZ121			5170	C38500	
	CW612N	CuZn40Pb2	2.0402	CuZn40Pb2	CuZn39Pb2	CZ120			5168	C37800	
CW622N	CuZn44Pb2	2.0410	CuZn44Pb2		CZ104			5272	C68700		

SMG

U.N.E./ I.H.A.	AISI / ASTM	GOST	Misc. Brands	Condition	Structure
	A48 25 B	Sc 15			Grey cast iron (GCI)
	A48 30 B	Sc 20			Grey cast iron (GCI)
	G 3500				Grey cast iron (GCI)
	A48 35 B	Sc 25			Grey cast iron (GCI)
	A48 45 B	Sc 30			Grey cast iron (GCI)
	A48 50 B	Sc 35			Grey cast iron (GCI)
	Grade 350				Compacted graphite irons (CGI)
	Grade 400				Compacted graphite irons (CGI)
	Grade 400-15				Compacted graphite irons (CGI)
	Grade 450				Compacted graphite irons (CGI)
	Grade 500				Compacted graphite irons (CGI)
	A220 60004			Tempered	Malleable cast irons (MCI)
					Nodular cast irons (SGI)
FGE 38-17	60-40-18	Vc 42-12			Nodular cast irons (SGI)
	60-40-18	Vc 42-12			Nodular cast irons (SGI)
FGE 50-7	A536 80-55-6	Vc 50-2			Nodular cast irons (SGI)
FGE 60-2	A476 80-60-03	Vc 60-2			Nodular cast irons (SGI)
FGE 70-2	A536 100-70-03	Vc 70-2			Nodular cast irons (SGI)
	1600/1300/-				Austempered cast irons (ADI)
	1050/700/7				Austempered cast irons (ADI)
	1200/850/4				Austempered cast irons (ADI)
	1400/1100/1				Austempered cast irons (ADI)
	850/550/10				Austempered cast irons (ADI)
	A436 Type 2		Ni-Resist 2		Austenitic lamellar cast irons
	A436 Type 3		Ni-Resist 3		Austenitic lamellar cast irons
	A436 Type 1		Ni-Resist 1		Austenitic lamellar cast irons
	A439 Type D-5		Ni-Resist D-5		Austenitic nodular cast irons
	A436 Type D-2		Ni-Resist D-2		Austenitic nodular cast irons
	A436 Type D-3		Ni-Resist D-3		Austenitic nodular cast irons
	-		Nodumag		Austenitic nodular cast irons
	A439 Type D-2M		Ni-Resist D-2M		Austenitic nodular cast irons
	A380				
	B26				
	AMS 4442				
	AZ61A				
	AZ80A				
	B85				
	A413.2				
	B390.0				
	CA952	BrA9ZH3L			
	CA955	BrA10ZH4N4L			
	CA937				
		BrOF6.5-0.15			
		L90			
		LOMsh70-1-0.05			
		LO60-1			
		LAMsh77-2-0.05			

SMG

SMG	EN	EN-Nr	W-Nr	DIN	AFNOR	BS	UNI	JIS	SS	UNS
S1										
S2										
S3	NiMo30		2.4810							N10002
	NiMo16Cr15W		2.4819							N10276
	NiCr19Fe19Nb5Mo3		2.4668							N07718
	NiCr20TiAl		2.4669							N07750
	NiCr20TiAl		2.4631							N07080
	NiCr19Co18Mo4Ti3Al3									N07500
NiCr20Co13Mo4Ti3Al			2.4654							N07001
S11			3.7024							
S12										R54620
S12										R56320
S12	TiAl6V4		3.7164							R56400
S13				TiV10Fe2Al3						
H3	16 MnCr 5	1.7131	1.7131	16 MnCr 5	16 MC 5	527 M 17	16 MnCr 5	SCR 415	2511	G51170
H5	42 CrMo 4	1.7225	1.1201	42 CrMo 4	42 CD 4	708 M40	42 CrMo 4	SCM 440 (H)	2244	G41400
	C 67S	1.1231	1.1231	Ck 67	XC 68	060 A 67	C 70		1770	G10700
	C 75S	1.1248	1.1248	Ck 75	XC 75	060 A 78	C 75		1774, 1778	G10780
	C 100S	1.1274	1.1274	Ck 101		060 A 96		SUP 4	1870	G10950
	C 105U	1.1545	1.1545	C 105 W1	Y1 105		C 100 KU		1880	
			1.2550		60 WCrV 7	55 WC 20		55 WCrV 8 KU		
	55 Cr 3	1.7176	1.7176	55 Cr 3	55 C 3	527 A 60	55 Cr 3	SUP 9 (A)	2253	G51550
H7	107 CrV 3	1.2210	1.2210	115 CrV 3	100 C 3		107 CrV 3 KU			T61202
			1.2510	100 MnCrW 4	90 MWCV 5	BO 1	95 MnWCr 5 KU	SKS 3	2140	T31501
	90 MnCrV 8	1.2842	1.2842	90 MnCrV 8	90 MV 8	BO 2	90 MnVCr 8 KU			T31502
	100 Cr 6	1.3505	1.3505	100 Cr 6	100 C 6	534 A 99	100 Cr 6	SUJ 2	2258	G51986
H8	X 40 CrMoV 5 1	1.2344	1.2344	X 40 CrMoV 5 1	Z 40 CDV 5	BH 13	X 40 CrMo 5 1 1 KU	SKD 61	2242	T20813
	X 100 CrMoV 5	1.2363	1.2363	X 100 CrMoV 5 1	Z 100 CDV 5	BA 2	X 100 CrMoV 5 1 KU	SKD 12	2260	T30102
	X 155 CrVMo 12 1		1.2379	X 155 CrVMo 12 1	Z 160 CDV 12	BD 2	X 155 CrVMo 12 1 KU	SKD 11		T30402
			1.2436	X 210 CrW 12			X 215 CrW 12 1 KU	SKD 2	2312	
			1.2601	X 165 CrMoV 12			X 165 CrMoW 12 KU		2310	
			1.2713	55 NiCrMoV 6	55 NCDV 7			SKT 4		T61206
	HS 6-5-2-5	1.3243	1.3243	S 6-5-2-5	Z 85 WDKCV 06-05-05-04-02		HS 6-5-2-5	SKH 55	2723	
	HS 2-10-1-8	1.3247	1.3247	S 2-10-1-8	Z 110 DKCWV 09-08-04	BM 42	HS 2-9-1-8	SKH 51		T11342
HS 6-5-2	1.3343	1.3343	S 6-5-2	Z 85 WDCV 06-05-04-0	BM 2	HS 6-5-2	SKH 9, SKH 51	2722	T11302	
HS 18-0-1	1.3355	1.3355	S 18-0-1	Z 80 WCV 18-04-01	BT 1	HS 18-0-1	SKH 2		T12001	
H11	X 20 Cr 13	1.4021	1.4021	X 20 Cr 13	Z 20 C 13	420 S 37	X 20 Cr 13	SUS 420 J 1	2303	S42000
	X 70 CrMo 15	1.4109	1.4109	X 65 CrMo 14	Z 70 D 14			SUS 440 A		S44002
	X 90 CrMoV 18	1.4112	1.4112	X 90 CrMoV 18	Z 2 CND 18 05	409 S 19	X CrTi 12	SUS 440 B	2327	S44003
	X 105 CrMo 17	1.4125	1.4125	X 105 CrMo 17	Z 100 CD 17		X 105 CrMo 17	SUS 440 C		S44004
H12	X 3 CrNiMoAl 13 8 2	1.4534	1.4534	X 3 CrNiMoAl 13 8 2						S13800
	X 5 CrNiCuNb 16 4	1.4548	1.4542	X 5 CrNiCuNb 17 4	Z 6 CNU 17.4			SCS 24, SUS 630		S17400
	X 7 CrNiAl 17 7	1.4568	1.4568	X 7 CrNiAl 17 7	Z 9 CAN 17.7	301 S 81	X 7 CrNiAl 17 7	SUS 631	2388	S17700
	X 6 NiCrTiMoV 25 15	1.4980	1.4943	X 4 NiCrTi 25 15	Z 6 NCTDV 25.15	HR 51		SUH 660	2570	S66286
H21	X 120 Mn 12	1.3401	1.3401	X 120 Mn 12	Z 120 M 12	BW 10		SC MnH 1	2183	
H31	EN-GJN-HV520	0.9620	G-X330 NiCr 4 2	FB Ni4 Cr2 BC	Grade 2 A	Grade 2 A			05 12-00	F45001
	EN-GJN-HV550	0.9625	G-X260 NiCr 4 2	FB Ni4 Cr2 HC	Grade 2 B	Grade 2 B			05 13-00	F45000
	EN-GJN-HV600(XCr11)	0.9630	G-X300 CrNiSi 9 5 2	FB Cr9 Ni5	Grade 2 C, D, E	Grade 2 C, D, E			04 57-00	F45003

SMG

U.N.E./I.H.A.	AISI / ASTM	GOST	Misc. Brands	Condition	Structure
			Discalloy	Precipitation hardened	
			Haynes 25		
			Stellite 21		
			Stellite 31		
			Hastelloy C		
		KHN65MV	Hastelloy C-276		
			IN 100		
			Inconel 718		
			Inconel X-750	Solution treated	
			Nimonic 80A		
			René 41		
			Udimet 500		
			Waspalloy		
			Ti	Commercially pure	Ti (α)
	AMS 4919		Ti 6-2-4-2	Annealed	Ti (α)
	AMS 4943		Ti 3Al-2.5V (grd 9)	Annealed	Ti ($\alpha+\beta$)
	AMS 4920, Grd 5	VT6	Ti 6Al-4V	Annealed	Ti ($\alpha+\beta$)
	AMS 4986		Ti 10V-2Fe-3Al	Annealed	Ti (β)
F.1516	5115	12KHN2		Case hardened	
F.1252	4142, 4140	38HM		Quenched & Tempered	
F.5103	1070	70		Quenched & Tempered	
F.5107	1078, 1080	75		Quenched & Tempered	
F.5117	1095			Quenched & Tempered	
F.5118	W 1	U10A		Quenched & Tempered	
	S1	5KHV2SF		Quenched & Tempered	
	5155			Quenched & Tempered	
F.520L	L2	11KHF		Quenched & Tempered	
F.5220	O1	9KHVG		Quenched & Tempered	
	O2	9G2F		Quenched & Tempered	
F.5230	52100	SHKH15		Quenched & Tempered	
F.5318	H13	4KH5MF1S		Quenched & Tempered	
F.5227	A2	9KH5VF		Quenched & Tempered	
F.5211	D2	KH12MF		Quenched & Tempered	
F.5213		KH12		Quenched & Tempered	
		KH12MF		Quenched & Tempered	
F.520.S	L6	5KHNM		Quenched & Tempered	
F.5613	M35	R6M5K5		Quenched & Tempered	
	M42	R2AM9K5		Quenched & Tempered	
F.5603	M2	R6M5		Quenched & Tempered	
	T1	R18		Quenched & Tempered	
F.5261	420	20KH13		Quenched & Tempered	Martensite
	440 A			Quenched & Tempered	Martensite
	440 B	95KH18		Quenched & Tempered	Martensite
	440 C	95KH18		Quenched & Tempered	Martensite
	XM-13		PH13-8Mo	Precipitation hardened	Martensite
	630		17-4-PH	Precipitation hardened	Martensite
	AMS 5528	09KH17N7YU1	17-7-PH	Precipitation hardened	Austenite/ferrite
	660		A286	Precipitation hardened	Austenite
	A128 Grade A				
	A532 IB (NiCr-LC)		Ni-Hard 2		White cast iron
	A532 IA (NiCr-HC)		Ni-Hard 1		White cast iron
	A532 ID (Ni-HiCr)		Ni-Hard 4		White cast iron

Cemented carbide inserts and insert carriers

Cemented carbide inserts and cemented carbide insert carriers from Seco Tools are not included in the product range intended for the following requirements. Nevertheless Seco Tools can make the following declaration.

These products meet all requirements in RoHS (Restriction of the use of certain Hazardous Substances in electrical and electronic equipment), WEEE (Waste Electrical & Electronic Equipment) and ELV (End of Life Vehicles) requirements.

Products do not contain mercury, lead, hexavalent chromium, cadmium, CFC, HCFC, flame retardants or solvents in concentrations that exceed specifications in the regulations.

Regrinding:

Wet or dry grinding can produce potentially hazardous dusts or mists that can irritate skin, eyes, nose, throat and result in lung damage or disease. To avoid injury use proper safety precautions and protective equipment.

Disposal:

Seco Tools will buy back used inserts and solid carbide tools for recycling. Inserts and solid carbide tools should be separated from other metal waste (steel, aluminium, copper etc).

All packing material is fully recyclable.

CBN and PCD inserts

Inserts from Seco Tools are not included in the product range intended for the following requirements. Nevertheless Seco Tools can make the following declaration.

This product meets all requirements in RoHS (Restriction of the use of certain Hazardous Substances in electrical and electronic equipment), WEEE (Waste Electrical & Electronic Equipment) and ELV (End of Life Vehicles) requirements.

Products do not contain mercury, lead, hexavalent chromium, cadmium, CFC, HCFC, flame retardants or solvents in concentrations that exceed specifications in the regulations.

Regrinding:

Wet or dry grinding can produce potentially hazardous dusts or mists that can irritate skin, eyes, nose, throat and result in lung damage or disease. To avoid injury use proper safety precautions and protective equipment.

Disposal:

Seco Tools will buy back used CBN- or PCD-tipped inserts for recycling. Inserts should be separated from other metal waste (steel, aluminium, copper etc). Solid CBN-inserts may be discarded as landfill waste.

All packing material is fully recyclable.

Black oxide insert carriers

Insert carriers from Seco Tools are not included in the product range intended for the following requirements. Nevertheless Seco Tools can make the following declaration.

This product meets all requirements in RoHS (Restriction of the use of certain Hazardous Substances in electrical and electronic equipment), WEEE (Waste Electrical & Electronic Equipment) and ELV (End of Life Vehicles) requirements.

Products do not contain mercury, lead, hexavalent chromium, cadmium, CFC, HCFC, flame retardants or solvents in concentrations that exceed specifications in the regulations.

Disposal:

Used insert carriers may be sent for recycling together with ordinary steel waste (swarf and discarded steel scrap) for recycling.

All packing material is fully recyclable.

Cermet inserts

Inserts from Seco Tools are not included in the product range intended for the following requirements. Nevertheless Seco Tools can make the following declaration.

This product meets all requirements in RoHS (Restriction of the use of certain Hazardous Substances in electrical and electronic equipment), WEEE (Waste Electrical & Electronic Equipment) and ELV (End of Life Vehicles) requirements.

Cermet grade C15M inserts do contain nickel and will leach nickel when in contact with the skin. Amount of leaching is higher than specified in norm SS-EN 1811 Reference test method for release of nickel from products intended to come into direct and prolonged contact with the skin. These norms are intended for products that are in direct and prolonged contact with the skin and are therefore not directly applicable for cermet inserts. Persons with known allergic reactions to nickel are advised to wear protective gloves when handling cermet inserts.

Regrinding:

Wet or dry grinding can produce potentially hazardous dusts or mists that can irritate skin, eyes, nose, throat and result in lung damage or disease. To avoid injury use proper safety precautions and protective equipment.

Disposal:

Used inserts may be recycled. Inserts should be separated from other metal waste (steel, aluminium, copper, etc) including cemented carbide inserts.

All packing material is fully recyclable.

Nickel coated insert carriers

Insert carriers from Seco Tools are not included in the product range intended for the following requirements. Nevertheless Seco Tools can make the following declaration.

This product meets all requirements in RoHS (Restriction of the use of certain Hazardous Substances in electrical and electronic equipment), WEEE (Waste Electrical & Electronic Equipment) and ELV (End of Life Vehicles) requirements.

Products do not contain mercury, lead, hexavalent chromium, cadmium, CFC, HCFC, flame retardants or solvents in concentrations that exceed specifications in the regulations.

Insert carriers do contain nickel and will leach nickel when in contact with the skin. Amount of leaching is not higher than norm SS-EN 1811 Reference test method for release of nickel from products intended to come into direct and prolonged contact with the skin.

These norms are intended for products that are in direct and prolonged contact with the skin and are therefore not directly applicable for insert carriers. Persons with known allergic reactions to nickel are advised to wear protective gloves when handling nickel coated insert carriers.

Disposal:

Used tools maybe sent for recycling together with ordinary steel waste (swarf and discarded steel scrap) for recycling.

All packing material is fully recyclable.

Intentionally added alloying elements

Grade	Cemented carbide										Coating						
	W	Ti	Ta	Nb	Co	Cr	Ni	Mo	C	N	Ti	Al	C	N	O	Si	Nb
CP20	■				■				■		■			■			
CP200	■				■	■			■		■			■			
CP300	■	■	■	■	■				■		■	■		■			
CP500	■				■	■			■		■	■		■			
CP600	■				■	■			■		■	■		■			
C15M	■	■	■	■	■		■	■	■	■							
CF	■		■		■		■	■	■								
CM	■		■		■		■	■	■								
DP2000	■		■	■	■				■		■	■	■	■	■		
DP3000	■	■	■	■	■				■	■	■	■	■	■	■		
F15M	■				■	■			■		■	■		■			
F25M	■	■			■	■			■		■	■		■			
F30M	■				■	■			■		■	■		■			
F40M	■				■	■			■		■	■		■			
HX	■				■	■			■		■						
H02	■		■		■	■			■		■						
H15	■				■	■			■		■						
H25	■				■	■			■		■						
KX	■				■	■			■		■						
MH1000	■				■	■			■		■	■		■			
MK1500	■		■		■				■		■	■	■	■	■		
MK2050	■		■		■	■			■		■	■	■	■		■	
MM4500	■				■	■			■		■	■	■	■	■		
MP1020	■	■	■	■	■				■		■						
MP1500	■		■	■	■				■		■	■	■	■	■		
MP2500	■		■	■	■				■		■	■	■	■	■		
MP3000	■				■	■			■		■	■	■	■	■		
MS2500	■		■	■	■				■		■	■	■	■	■		
MS2050	■				■	■			■		■	■	■	■			
RX1500	■		■		■		■	■	■		■	■	■	■	■		
RX2000	■		■		■	■			■		■	■	■	■	■		
T350M	■		■	■	■				■		■	■	■	■	■		
T25M	■		■	■	■				■		■	■	■	■	■		
TGK1500	■		■		■				■		■	■	■	■	■		
TGP25	■	■	■	■	■				■		■	■	■	■	■		
TGP35	■		■	■	■				■		■	■	■	■	■		
TGP45	■		■	■	■				■		■	■	■	■	■		
TH1000	■				■	■			■		■	■	■	■	■		■
TH1500	■				■	■			■		■	■	■	■	■		
TK1001	■				■	■			■		■	■	■	■	■		
TK2001	■		■		■	■			■		■	■	■	■	■		
TM2000	■	■	■	■	■				■	■	■	■	■	■	■		
TM4000	■	■	■	■	■				■	■	■	■	■	■	■		
TP0500	■	■	■	■	■				■		■	■	■	■	■		
TP0501	■	■	■	■	■	■			■		■	■	■	■	■		
TP1020	■	■	■	■	■				■	■	■						
TP1030	■	■	■	■	■				■	■	■			■		■	
TP1500	■	■	■	■	■				■	■	■	■	■	■	■		
TP1501	■	■	■	■	■				■	■	■	■	■	■	■		
TP200	■	■	■	■	■				■	■	■	■	■	■	■		
TP2500	■	■	■	■	■				■	■	■	■	■	■	■		
TP2501	■	■	■	■	■	■			■	■	■	■	■	■	■		
TP40	■		■	■	■				■		■	■	■	■			
TS2000	■				■	■			■		■	■	■	■			
TS2500	■		■		■				■		■	■	■	■			
T250D	■				■	■			■		■	■	■	■			
T400D	■				■	■			■		■	■	■	■			
T100R	■				■	■			■		■	■	■	■			
T60M	■	■	■	■	■				■		■	■	■	■			
883	■		■		■				■		■						
890	■				■	■			■		■						