



COMPLETE METALWORKING SOLUTIONS
 (800) 991-4225 www.ahbinc.com
 ISO Certified customerservice@ahbinc.com



TOOL COMPANY, INC.

PREMIER TOOLING FOR THE MANUFACTURING INDUSTRY

*Rotary Broaching, Form Tooling, Dovetail Blanks,
 Workholding, Toolholding and more*

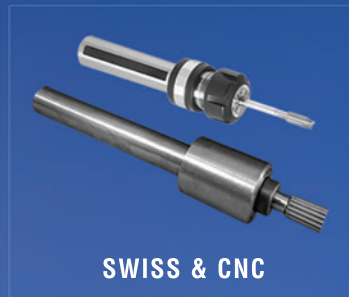
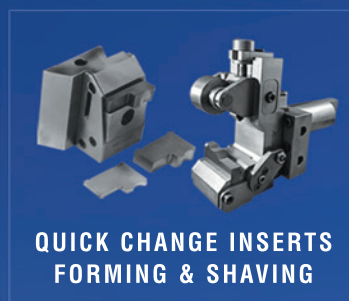

WEB

SOMMATOOL.COM

EMAIL

SALES@SOMMATOOL.COM

PHONE

(203) 753-2114

109 SCOTT ROAD, WATERBURY, CT 06705

*And now featuring our Max-Bar division
 of indexable insert tooling
 for CNC and Swiss*



A DIRECTORY OF TOOLING AVAILABLE FROM SOMMA TOOL COMPANY

Box Turning

Tangi-Square Insert Box Turning
Triangular Insert Box Turning
H.S.S. Tool Bit Box Turning

Broaching, Internal

Swiss Adjustment Free Broach Tool Holders
Adjustable Broach Tool Holders
CNC Adjustment Free Broach Tool Holders
Index Punch Broaching
Broaches 8mm, 1/2", & 3/4" Dia.
Gages: Set Up & Go / No Go

Broaching, External

External Broach Tool Holders & Broaches

Bushings / Tool Holding

Split Drill & Tap Bushings
Type B, C, DD, J, L, LB, LBF, & Z Tool
Holder Bushings
Boring Bar Sleeves
Taper Drill Sockets
B&S Slotting Bushings

Collets / Tool Holding

ER Drill & Tap Collets
TG Drill & Tap Collets
Erickson® "DA" Drill Collets
Universal® Acura-Flex Drill Collets
Sandvik® / Balas "C" Series Drill & Tap Collets
5C Collets & R8 Collets

Cutting-Off

Indexable Carbide Insert Cut Offs
For Swiss, CNC, Davenport, & B&S
Davenport & B&S Circular C/O & C/O
Blade Holders
T-Type C/O Blades & Acme C/O Blades
Johnson Hollow Ground C/O Blades
Twin Tip, Empire Style C/O Blades
Davenport Circular Resharpenable Insert
C/O Holders

Drilling *

Davenport & B&S Drill Holders
Quick Change ER Collet System
ER Collet, Collet Chucks
ER Collet Double Ended Collet Chucks
DA & TG Collet, Collet Chucks
Automotive Threaded Shank Collet Chucks
Solid Carbide Drills
Flat Drill Blanks
Drill Blanks

Endmills *

Solid Carbide

End Working *

Davenport Countersink
Countersinking
Spot Drilling
Recess Tool Holders & Tool Blanks
Tube End Forming Tooling
Outside Deburring & Chamfering
Inside Deburring & Chamfering

Forming & Shaving

RQC Quick Change Resharpenable
Form & Shave Tool System
STAI Economical Quick Change
Form Tool System
Form Tool Calculation Program
Spindle Speed/Surface Feet Calculator
Dovetail Form Tool Holders
Form Tool Blanks & Shave Tool Blanks
Dovetail Checking Gages
Dovetail Sharpening Fixtures
Rectangular & Square Form Tool Blanks

Knurling

Davenport Knurling Tools
Self Centering Straddle Knurl Tools
Adjustable Straddle Knurl Tools
Swiss In-Line & T Style Straddle Knurl Tools
Bump Style Single Knurl Tools
Knurls

Max-Bar Swiss Mini Shank Tooling

Full Range of Swiss Turning Holders
& Inserts in Six Different I.C. Sizes for:

- Front & Back Turning
- Cutting Off
- Grooving
- Threading
- Plunge & Turn
- Face Grooving
- as well as I.D. Grooving, Threading & Boring

Reaming

ER Collet Floating Reamer Holder
DA Collet Floating Reamer Holder
VDI Shank ER Collet Floating Reamer Holders
Morse Taper Shank ER Collet Holder
Solid Carbide Reamers

Taper Shank Tooling

CAT40 & CAT50 Tool Holders
BT40 & 50 Tool Holders

Tapping

Tapping / Re-Tapping Second Operation
Tension / Compression & Tension Only
ER Collet Tap Holders
Non-Releasing Tap Holders
Releasing Tap Holders

Workholding

Bar Pullers

* See Our Website for Further Details

Please visit our website www.sommatool.com for a complete listing of our products.

Somma Tool Company is the leading manufacturer in the United States to offer a full line of tooling for screw machines. We offer preset and quick change tooling in addition to cutting tools, tool holders, work holders and accessories for screw machines, turret lathes and CNC lathes. Our goal is to provide superior value and innovation in our products and services, and to conduct all of our business activities with our customers, distributors, employees and vendors with integrity and respect. Our products are sold through a nationwide and worldwide network of distributors. Contact us today.

SOMMA / MAX-BAR MINI SHANK TOOLING

Designed to fit your Swiss type CNC screw machine without the need of modification or large offsets.

- Inserts are precision ground for repeatability
- Widest choice of inserts per holder
- Zero radius as standard

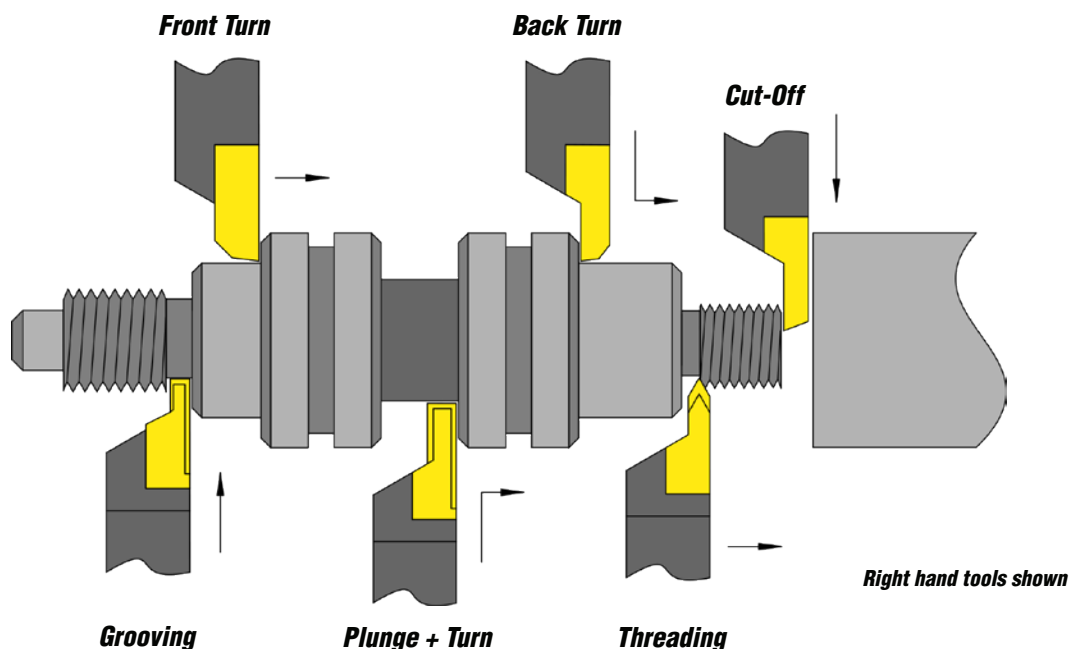

Inserts are also available for Face Grooving, I.D. Grooving, I.D. Threading, and I.D. Boring



Diamond insert style, offered in 3 series sizes:

Series 6 (6mm I.C.)

Series 8 (8mm I.C.)

Series 50 (1/2" I.C.)

Triangular insert style, offered in 3 series sizes:

Series 10 (3/8" Dia. Cap.)

Series 16 (5/8" Dia. Cap.)

Series 20 (3/4" Dia. Cap.)



Please visit our website www.sommatool.com for a complete listing of our products.



ROTARY BROACHING

from **Somma**
featuring our **FORTE** material



**The Toughest Broaching
Material Available**

**Improved Wear Resistance
for Better Tool Life**

**Industry Leading
Depth of Cut**

**Industry-Wide
Compatibility**

**Largest Stock of ANSI Hex
& Squares Available for
Same Day Shipping**

**Special Hex & Square
Sizes Available
in 1-2 Days**

**Internal adjustment-free holders available
for Swiss and CNC lathes and mills.**

**Internal & External adjustable holders
available for Davenport, Brown & Sharpe
and multi-spindle screw machines.**

**Made to print Internal & External
broaches are promptly quoted and
manufactured!**



Please visit our website www.sommatool.com for a complete listing of our products.

FORM TOOL FREEDOM

The freedom to choose the holders and inserts that best suit your product requirements.

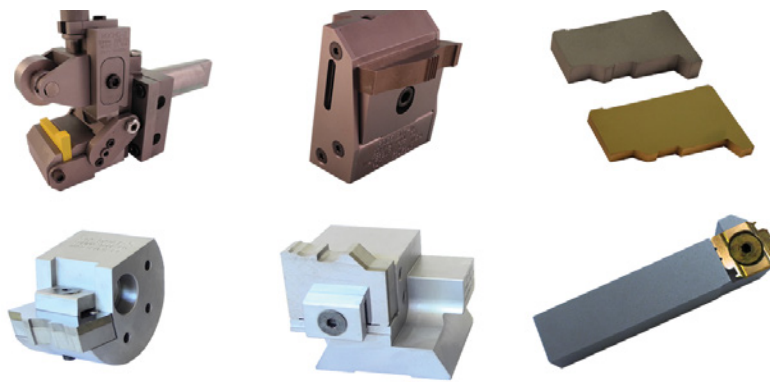

Learn more at
FormToolFreedom.com

RQC

RESHARPENABLE
QUICK CHANGE

Economical inserts
20-30 uses from 1 Insert

Always on center after
resharpening

Great for part families

Can also accept
single-use inserts

STA

SINGLE-USE
THROW-AWAY

Economical
holders

Compact yet
rigid design

0° or 5° top rakes

DIY

MAKE YOUR
OWN INSERTS

Have control over your
design and deliveries!
We provide the insert
blanks and EDM fixtures
so you can make your
own inserts in-house.

SES

SOMMA ENGINEERING
SERVICES

Our tool design
engineers will design
the inserts from the part
prints you send us. We'll
provide you with a PDF
print and DXF file so you
can start cutting your
inserts immediately.

We also offer a full line of dovetail and circular tool blanks. We can even supply them finished to your part print.

See next page for details.

Please visit our website www.sommatool.com for a complete listing of our products.

FORMING & SHAVING

Somma Tool Company has been the leader in circular and dovetail tool blanks since 1939.

- Blanks are stocked in M42, T15PM, 76PM. We can also quote M2 upon request.
- Dovetails are also available Carbide Tipped.
- Semi-standard blanks and cutting tools engineered to your print can also be quoted.

Dovetail Form & Shave Tool Blanks

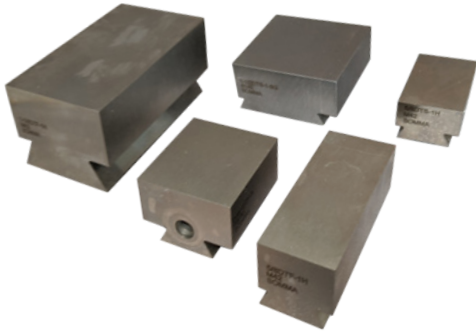

Circular Form & Shave Tool Blanks



Flat Form Tool Blanks

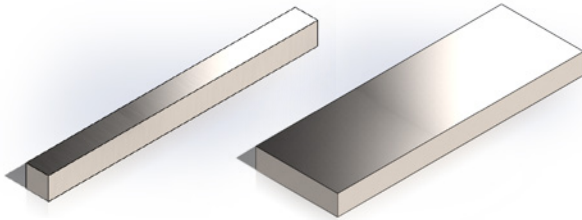

EDM Wire Ready HSS Bars

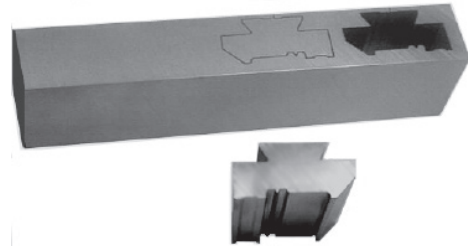

SHARPENING FIXTURES

**Adjustable Dovetail
Sharpening Fixtures**

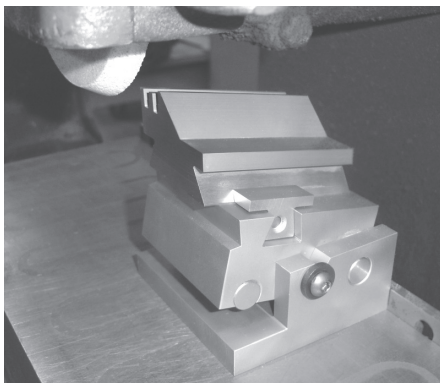

**Dovetail Sharpening Fixtures
For 12° and 17° Angles**



Please visit our website www.sommatool.com for a complete listing of our products.

CUT OFF BLADES



T Type Style

- Ground all over
- Concave ground top
- Blade centered

JCO (Johnson Style) Hollow ground style

- Ground all over

HIGH SPEED STEEL (HSS) BLADES ARE STOCKED IN M2, COBALT, AND T15PM.



Carbide Tipped T Type & Hollow Ground

- Micro-grain carbide for increased feeds

Solid Carbide T Type Style

- Longer wearing, less galling, better finish, higher speeds than high speed steels, greater rigidity & up to 10x the resharpenable tool life of carbide tipped blades.

Other cut off blades are also available including:

Carbide Tipped / Short Length T Type, Empire® Twin-Tip, and Acme “B” Type 7 Degree Beveled Style

H.S.S. Cut-Off Blade *Grinding* Options

- CB = Chip Breaker groove ground along the top length of the blade
- TAPER = Side taper ground front to back along T portion of the blade

H.S.S. Cut-Off Blade *Coating* Options

- TIN = A good general purpose coating for metal cutting
- TICN = This coating is recommended for machining high carbon steel, high silicon aluminums and tool steels
- TIALN = For machining cast iron, high nickel and titanium alloys, hardened steels and stainless steels. Good choice for interrupted applications
- NF = For non-ferrous materials like brass, copper, bronze & some aluminums

**** Many more specialized coatings are also available. ****

QUICK CHANGE CARBIDE INSERTED CIRCULAR CUTOFF HOLDERS

For Davenport 5th Position, B&S Machines, and CNC Machines

- Quick Change - Just rotate insert without removing holder from machine (4 usable edges)
- Never Loses Center Setting - even when changing from one size cut-off insert to another
- Free Cutting - inserts ground with both front to back and top to bottom clearance - eliminates side rubbing and dragging
- Longer Life - Micro-grain carbide outperforms conventional carbide grades

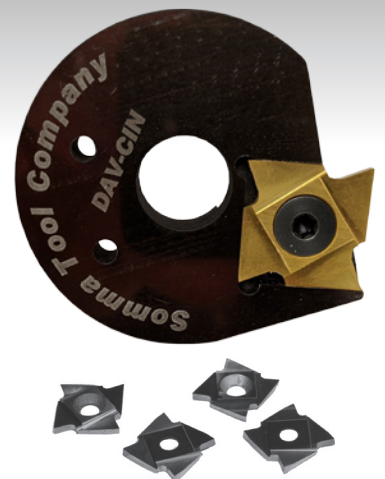

Please visit our website www.sommatool.com for a complete listing of our products.

RE-TAPPING AND TAPPING MACHINES



BB-SR Retapping Machine

Deburr holes, countersink holes, chase threads, retap threaded parts

- 5/64" - 1/2" capacity chuck
- Retap threaded parts
- Chase threads
- Remove cut off burrs from threads
- Inspect threads
- Countersink holes
- Deburr holes
- Ream holes



STC-TAP-ER Tapping Machine

Heavy duty tapered cone drive taps up to 5/16-18 thread in 1/2" steel!

- 5/64" - 1/2" capacity chuck
- Push to tap in / pull to tap out
- Sliding face plate
- Easy to set stop for tap depth
- Comfortable bench height working area
- Long lasting tapered cone drive
- Pilot light switch

Both machines are also available with a variable speed motor

BAR PULLERS FOR CNC

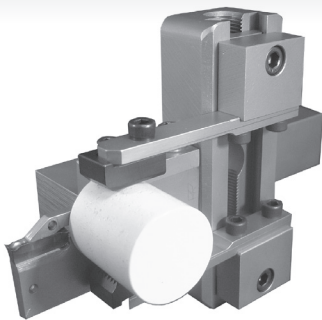

Combination Bar Puller Cut-Off Tool

Gripping Range 1/8" - 3-1/4"

- Single wrench turn adjusts both gripping jaws
- Infinite size adjustment within the gripping range
- Quick change over adjustment to the next job
- Allows easy mounting and removal in any wedge lock turret
- Also allows mounting of the shank in any position in the tool holder pocket



Bar Puller

- 1-1/16" Dia min to up to 2-1/2" Dia max adjustable pulling range for BP00 up to BP4
- 1-1/16" Dia min to up to 3" Dia max adjustable pulling range for BP5
- No springs, tension built into jaws for up to 250 lbs. of gripping pressure
- Jaws are easily replaced

Please visit our website www.sommatool.com for a complete listing of our products.

ACCU-SET TURNING TOOLS

With Exclusive TANGI-SQUARE QUICK CHANGE Micro-Grain Carbide Inserts

TANGI-SQUARE Carbide Inserts outperform all other inserts:

- Cut tangentially - not radially, Repeatability within .001"
- Shave turned diameter for better size control and finish
- Freer cutting action eliminates scroll lines on most applications
- 4 right hand cutting edges, produce square, sharp corners
- MICRO-GRAIN carbide for longest tool life
- Ideal 10° front clearance angle instead of 5° of triangular inserts
- For jobs on CNC lathes which do not have a tailstock
- For jobs that have a high diameter to

length ratio

- **Available:** 35° high top rake, and 5° top rake Square corner, .015 and .031 corner radius

The only insert ever designed specifically for screw machine turning tools!

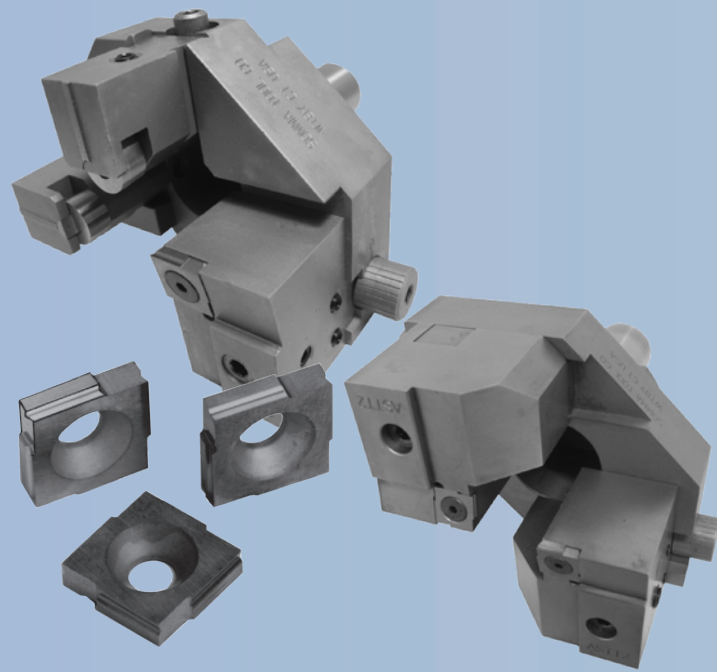

Cat. No. Rolling Style Cat. No. Balance Style	ASTT00 BASTT00	ASTT0 BASTT0	ASTT2 BASTT2
Shank Size Insert Series* Insert Max. Depth of Cut	5/8" Dia. x 1-9/32" TSQ00-..... 3/16"	3/4" Dia. x 1-1/2" TSQ2-..... 17/64"	1" Dia. x 1-15/16" TSQ2-..... 17/64"
Turning Capacities	5/64" to 3/8" Dia. will pass thru shank 25/64" to 1/2" Dia. x 1-3/8" Length	5/32" to 1/2" Dia. will pass thru shank 33/64" to 7/8" Dia. x 1-7/8" Length	3/16" to 5/8" Dia. will pass thru shank 41/64" to 1-1/4" Dia. x 2-3/4" Length

WIDE SELECTION OF COLLET CHUCKS

ER, DA, TG, AF, and Flexi Grip Collets



ER Collets



Double Angle Collets



TG Collets



Acura Flex Collets



**Flexi Grip
Collets**



**Large Nut
Collet Chucks**



**Extended Nose
Collet Chucks**



**Adjustable Flange
Collet Chucks**

Please visit our website www.sommatool.com for a complete listing of our products.

KNURL TOOL HOLDERS

Straddle Knurling Tool with Adjustable Knurl Angle

- Knurl can be adjusted to produce straight, diagonal, or diamond knurls by rotating the barrels.
- Holds drills for combined operations
- Standard with carbide knurl pins
- Same tool can be converted to “extra capacity” by changing barrels.

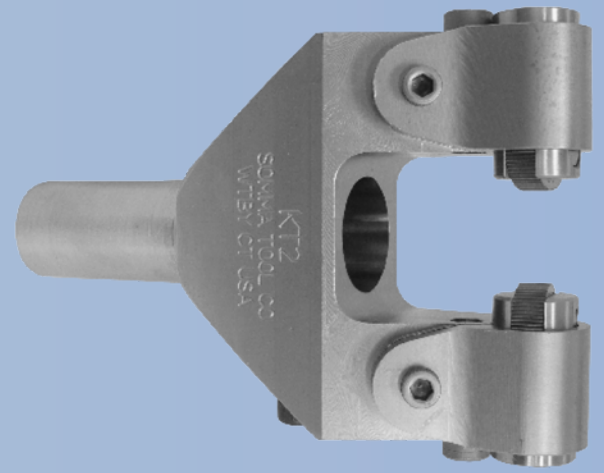

**Swiss Inline
Straddle Holders**

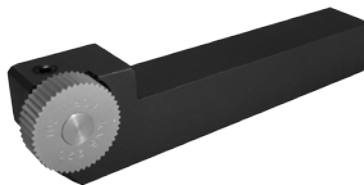

**Up to the
Shoulder Bump Holders**

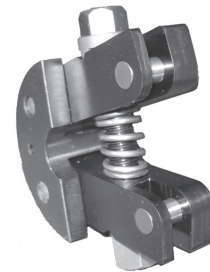

**Straddle Knurl Holder
for Davenport**

DRILL & TAP BUSHINGS



Precision Ground

Inside/Outside Dia. 1/2", 5/8", + 1" O.D.

Heat Treated

For Longer Life

Various Inside Diameters

Fractional, Letter, Metric & Tap

Better Than Ever

Improved Concentricity

Wedge Split

Grips Entire Length of Shank

TOOL HOLDER BUSHINGS

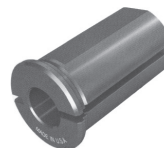

Type B



Type C + CS

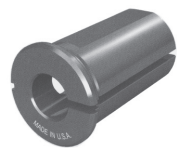

Type DD



Type J



Type LB



Type LBF



Type L



Type Z

Please visit our website www.sommatool.com for a complete listing of our products.

ER COLLET FLOATING REAMER HOLDERS

- The free moving ball bearing drive allows reamers to follow the existing drilled hole for high quality work.
- Could be used for synchronized tapping operations on lathes and CNC machining centers.
- Through the shank coolant capability

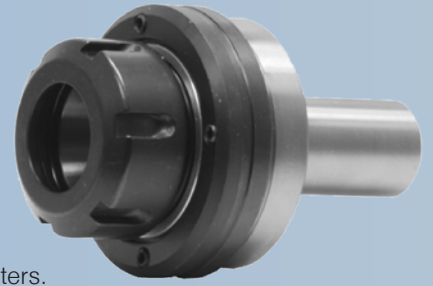

TENSION & COMPRESSION ER COLLET FLOATING TAP HOLDERS

- Axial-float/tension/compression for CNC lathes & milling machines with reversing motors and rigid tapping.
- Compensates for machine feed and tap pitch variance.
- Floating mechanism (.002 per side / .004 total float) compensates for misalignment between tap and work piece.
- Compact design for minimal clearance applications.
- Uses ER Series Tap Collets.



RELEASING TAP HOLDERS

The patented unique releasing mechanism of the Somma R&L Tap Holder is unequalled for dependability and accuracy which resulted in its selection for usage as original equipment by many machine tool manufacturers.

- For right or left hand threading
- Eases tap into work for better matching of threads
- Simple operation
- No spring plungers to wear or break
- No. 000 size is extremely sensitive for small taps when used on high speed machines



NON-RELEASING TAP HOLDERS

- Excellent for operations where release is not required.
- Smooth, extra long pullout.

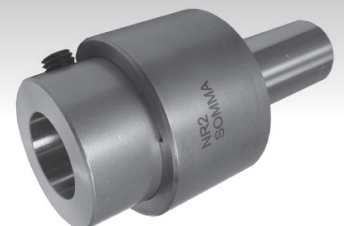

Please visit our website www.sommatool.com for a complete listing of our products.

Somma

Broaching

Swiss Turn

Form & Shave

Dovetail Blanks

Cut Off

Box Turn

End Working

Knurling

Tapping

Reaming

Drilling

Tool Bushings

Tool Collets

V-Flange Collet Chucks

Endmills

Workholding

and More

Somma
TOOL COMPANY, INC.

109 Scott Road

Waterbury, CT 06705 USA

(203) 753-2114 FAX (203) 756-5489

www.sommatool.com EMAIL sales@sommatool.com

Copyright © 2020

Made in the U.S.A. 