

SOWA®

TOOLING
YOUR
WORLD.

AHB

TOOLING & MACHINERY

COMPLETE METALWORKING SOLUTIONS

(800) 991-4225

www.ahbinc.com

ISO Certified

customerservice@ahbinc.com



Angle Heads & Driven Tools



Right Angle Head (VRA-Type)	2
GS Driven Tools	2
GS Fixed Heads	4-13
GS Pivoting Heads	14-15

Angle Heads & Driven Tools

Right Angle Head (VRA-Type)

1. Used on Vertical Milling Machine to make horizontal cutting work
2. Rigidity constructed suitable for heavy-duty cutting
3. The clamping bushing to suit milling machine



Suitable Milling Head Quill Diameter	Weight	Model No.	Code No.
85.725mm - 86mm	12 kgs	VRA-R8	326200
85.725mm - 86mm	13 kgs	VRA-NT 30	326202
105mm	20 kgs	VRA-NT 40	326204



DRIVEN TOOLS

2 Year Warranty
(against manufacturer defects)

Main Technical Features

- Main body designed to maximize rigidity and reduce vibration
 - Specially treated corrosion resistant steel body
 - Angular contact bearings + taper roller bearings on output spindle for better rigidity and longer life
 - Gleason spiral bevel gears with completely ground involute form
 - Internal coolant option
 - Designed, manufactured and assembled in Italy
 - 2 Year warranty against manufacturer defects
- ▼ Direction of rotation is opposite to the machine spindle
 ▼ Direction of rotation is the same as the machine spindle

Driven Tools For DMG MORI Lathes

Model	Orient	Rotation	Turret	Output	Int. Coolant	Nm	RPM	Gage Length	Code No.
99.MS.A59	Axial	▼	NL60	ER-32	-	60	10,000	Max 89.9	381504
99.MS.A60	Axial	▼	NL60	ER-32	• 80bar	60	10,000	Max 89.9	381505
99.MS.A72	Radial	▼	NL60	ER-32	-	60	10,000	90	381506
99.MS.A73	Radial	▼	NL60	ER-32	• 80bar	60	10,000	90	381507



Driven Tools For DOOSAN Lathes

Model	Orient	Rotation	Turret	Output	Int. Coolant	Nm	RPM	Gage Length	Code No.
99.DS.A01	Axial	▼	BMT55	ER-25	-	40	8,000	57.2	381512
99.DS.A02	Axial	▼	BMT55	ER-25	• 80bar	40	8,000	57.2	381513
99.DS.A11	Radial	▼	BMT55	ER-25	-	40	8,000	70	381514
99.DS.A12	Radial	▼	BMT55	ER-25	• 80bar	40	8,000	70	381515
99.DS.A41	Axial	▼	BMT65	ER-32	-	70	6,000	72.5	381516
99.DS.A42	Axial	▼	BMT65	ER-32	• 70bar	70	6,000	72.5	381517
99.DS.A51	Radial	▼	BMT65	ER-32	-	70	6,000	72	381518
99.DS.A52	Radial	▼	BMT65	ER-32	• 70bar	70	6,000	72	381519



Driven Tools For HAAS Lathes

Model	Orient	Rotation	Turret	Output	Int. Coolant	Nm	RPM	Gage Length	Code No.
99.HA.590082	Axial	▼	VDI40	ER-32	-	63	6,000	82.1	381500
99.HA.590082B	Axial	▼	VDI40	ER-32	• 25bar	63	6,000	82.1	381501
99.HA.590084	Radial	▼	VDI40	ER-32	-	63	6,000	Max. 75	381502
99.HA.590084B	Radial	▼	VDI40	ER-32	• 25bar	63	6,000	Max. 75	381503



Driven Tools For MAZAK Lathes

Model	Orient	Rotation	Turret	Output	Int. Coolant	Nm	RPM	Gage Length	Code No.
99.MZ.A58	Offset-Axial	▼	QTN2-40	ER-32	-	80	6,000	50	381508
99.MZ.A59	Offset-Axial	▼	QTN2-40	ER-32	• 80bar	80	6,000	116	381509
99.MZ.A65	Radial	▼	QTN2-40	ER-32	-	80	6,000	130	381510
99.MZ.A66	Radial	▼	QTN2-40	ER-32	• 80bar	80	6,000	130	381511





ANGLE HEADS

ATC Series

Designed for Automatic Tool Change Machines

Design

The compact design, along with mentioned specifications allows for the highest performances, high speeds and long tool life

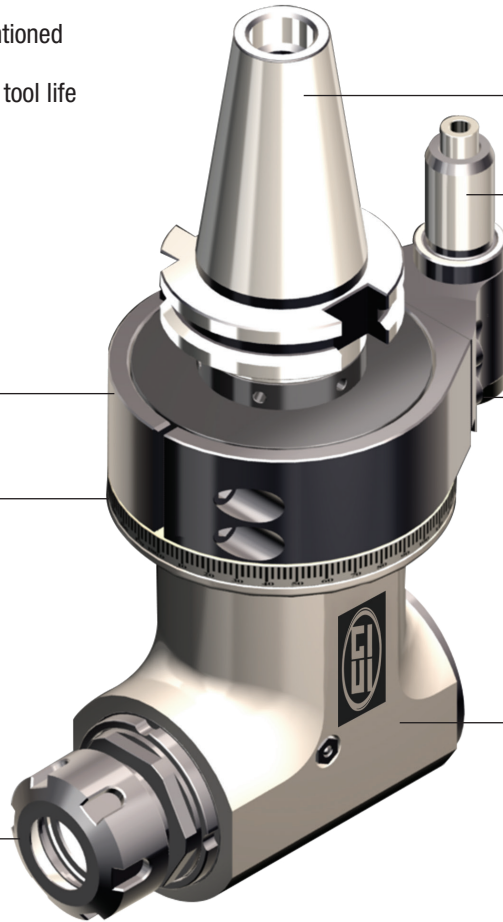

Case Hardened and ground shank and shaft

Positioning pin with automatic release

Modular anti-rotation group

Standard 10Bar coolant through pin

Graduated ring

Treated steel head body with 360° position and internal air pressure, maximum rigidity and corrosion resistant. Minimum thermal expansion

Output

- ER Collet (Standard)
- Weldon
- Shell mill holder
- Special

Angular contact preloaded ball bearings of precision class ABE 7/9



Gleason ground spiral bevel gears for maximum performance and minimum vibration





ANGLE HEADS

ATC Series

GFX07

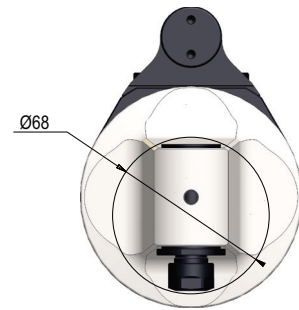
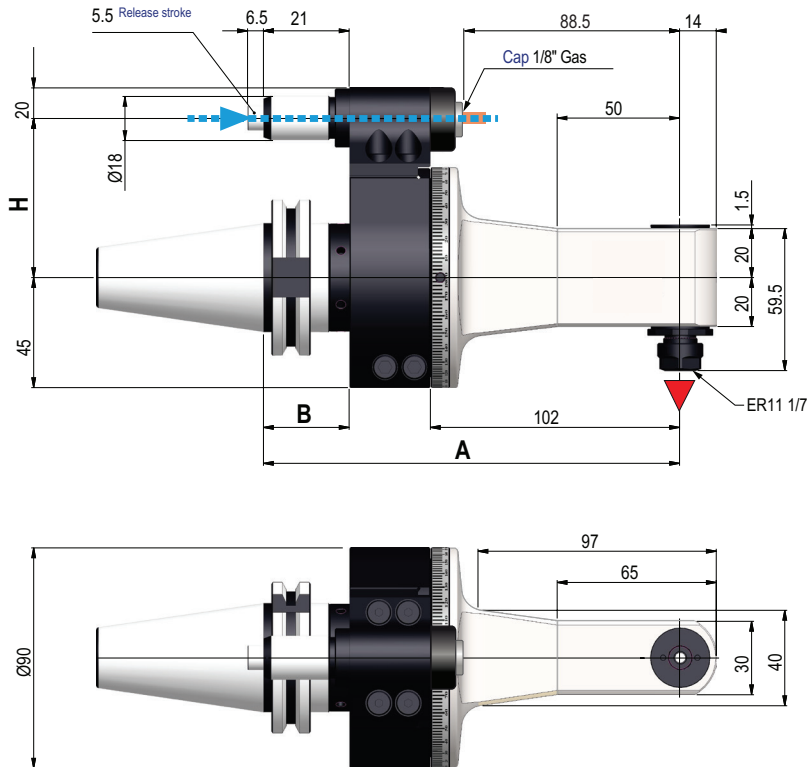

GFX07 ER11 Fixed 90° Right Angle Heads

▼ Direction of rotation is opposite to the machine spindle



Taper	Model	Collet System	A (mm)	B (mm)	H (mm)	End Mill & Drill Cap. (mm)	Tap Size Capacity	Max RPM	Weight (Kg.)	Code No.
CAT40	GFX07	ER11	170	35	65	7	M6	10,000	4	381002S
CAT50	GFX07	ER11	170	35	80	7	M6	10,000	4	381004S
BT40	GFX07	ER11	170	35	65	7	M6	10,000	4	381006S
BT50	GFX07	ER11	176	41	80	7	M6	10,000	4	381008S
HSK63	GFX07	ER11	177	42	65	7	M6	10,000	4	381010S
HSK100	GFX07	ER11	180	45	80	7	M6	10,000	4	381012S

Other tapers available, please inquire.
* For Haas machines please contact Customer Service

Technical Data		GFX 7
Ratio		1:1
RPM Max		10,000
Max axial load	N	120
Torque	Nm	5
Weight	Kg.	4
Collet	mm	ER11 1mm-7mm

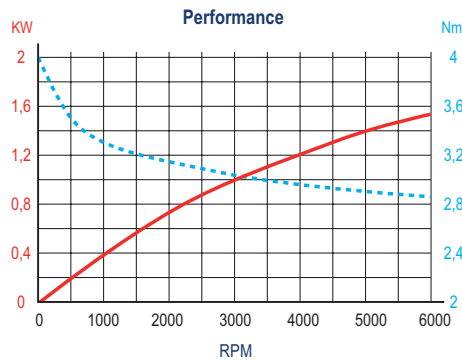

Standard Features & Equipment Included:

- Internal coolant from positioning pin
- Internal air pressure
- Retaining block
- Wrenches
- Grease tube
- Instruction book and Inspection report





ANGLE HEADS

ATC Series

GFX07L

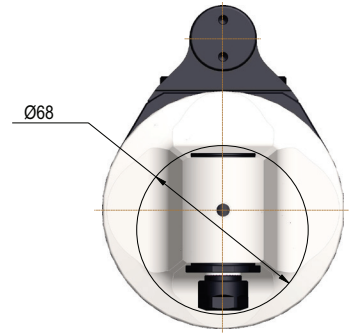
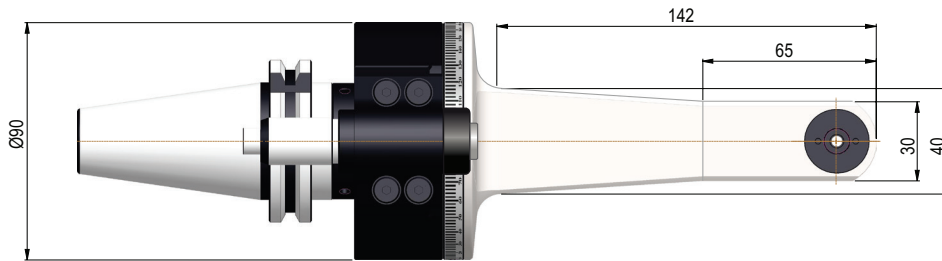
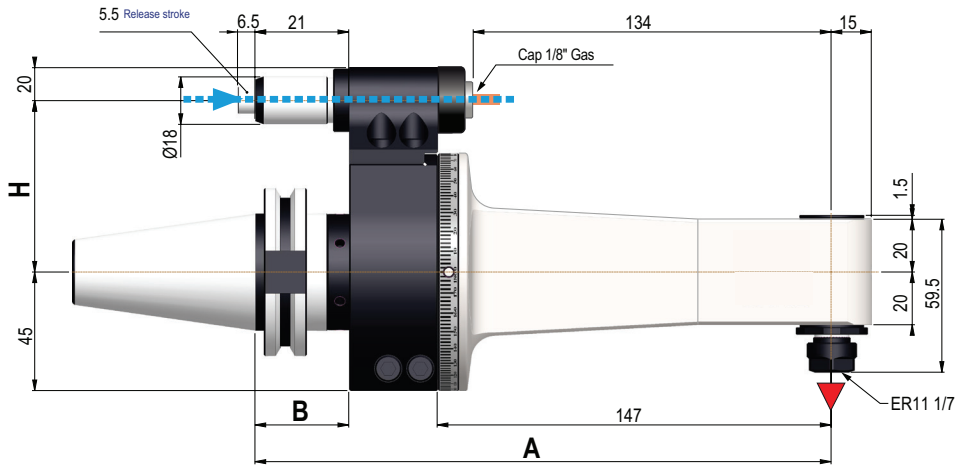

GFX07L ER11 Long Fixed 90° Right Angle Heads

▼ Direction of rotation is opposite to the machine spindle



Taper	Model	Collet System	A (mm)	B (mm)	H (mm)	End Mill & Drill Cap. (mm)	Tap Size Capacity	Max RPM	Weight (Kg.)	Code No.
CAT40	GFX07L	ER11	215	35	65	7	M6	10,000	4.3	381302S
CAT50	GFX07L	ER11	215	35	80	7	M6	10,000	4.3	381304S
BT40	GFX07L	ER11	215	35	65	7	M6	10,000	4.3	381306S
BT50	GFX07L	ER11	221	41	80	7	M6	10,000	4.3	381308S
HSK63	GFX07L	ER11	222	42	65	7	M6	10,000	4.3	381310S
HSK100	GFX07L	ER11	225	45	80	7	M6	10,000	4.3	381312S

Other tapers available, please inquire.

* For Haas machines please contact Customer Service

Technical Data		GFX 7L
Ratio		1:1
RPM Max		10,000
Max axial load	N	120
Torque	Nm	5
Weight	Kg.	4.3
Collet	mm	ER11 1mm-7mm

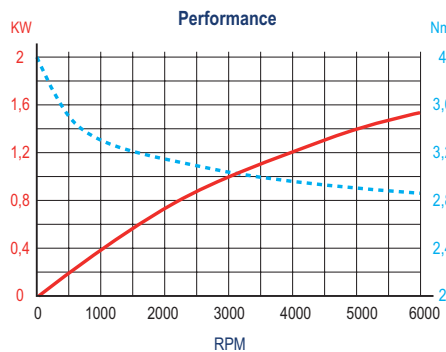

Standard Features & Equipment Included:

- Internal coolant from positioning pin
- Internal air pressure
- Retaining block
- Wrenches
- Grease tube
- Instruction book and Inspection report





ANGLE HEADS

ATC Series

GFX10

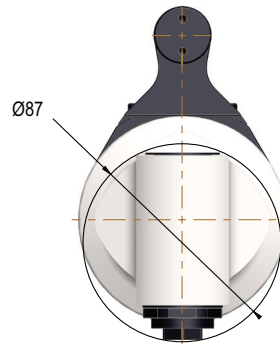
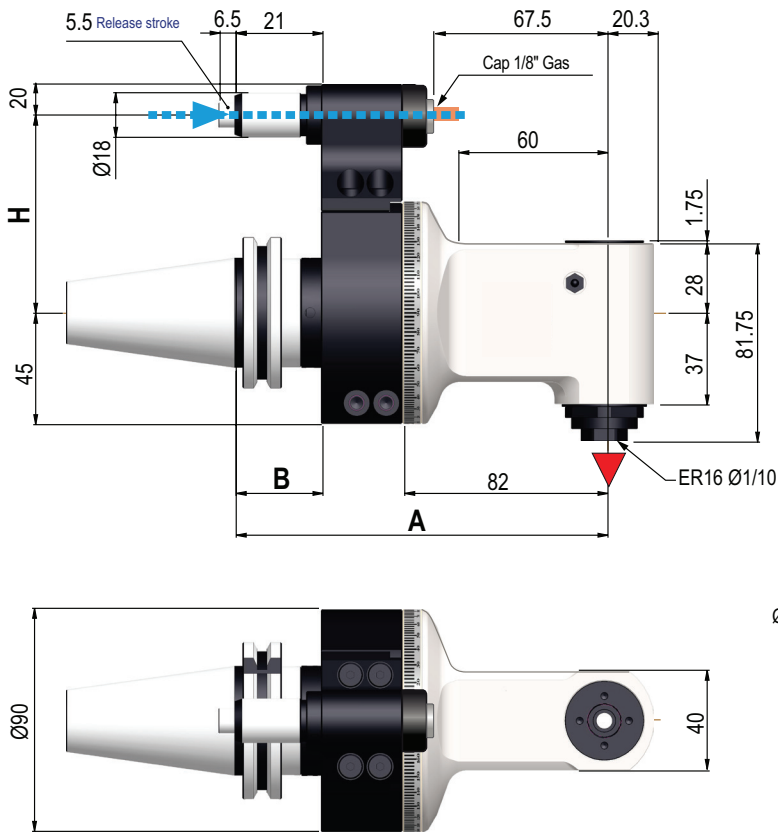

GFX10 ER16 Fixed 90° Right Angle Heads

▼ Direction of rotation is opposite to the machine spindle



Taper	Model	Collet System	A (mm)	B (mm)	H (mm)	End Mill & Drill Cap. (mm)	Tap Size Capacity	Max RPM	Weight (Kg.)	Code No.
CAT40	GFX10	ER16	150	35	65	10	M8	10,000	4.3	381020S
CAT50	GFX10	ER16	150	35	80	10	M8	10,000	4.3	381022S
BT40	GFX10	ER16	150	35	65	10	M8	10,000	4.3	381024S
BT50	GFX10	ER16	156	41	80	10	M8	10,000	4.3	381026S
HSK63	GFX10	ER16	157	42	65	10	M8	10,000	4.3	381028S
HSK100	GFX10	ER16	160	45	80	10	M8	10,000	4.3	381030S

Other tapers available, please inquire.
* For Haas machines please contact Customer Service

Technical Data		GFX10L
Ratio		1:1
RPM Max		10,000
Max axial load	N	250
Torque	Nm	10
Weight	Kg.	4.3
Collet	mm	ER16 1mm-10mm

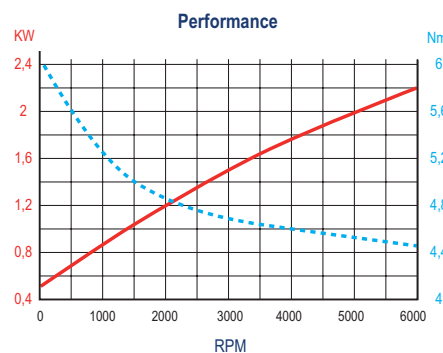

Standard Features & Equipment Included:

- Internal coolant from positioning pin
- Internal air pressure
- Retaining block
- Wrenches
- Grease tube
- Instruction book and Inspection report





ANGLE HEADS

ATC Series

GFX10L

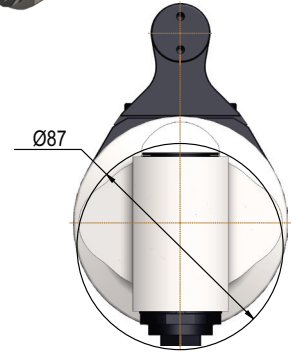
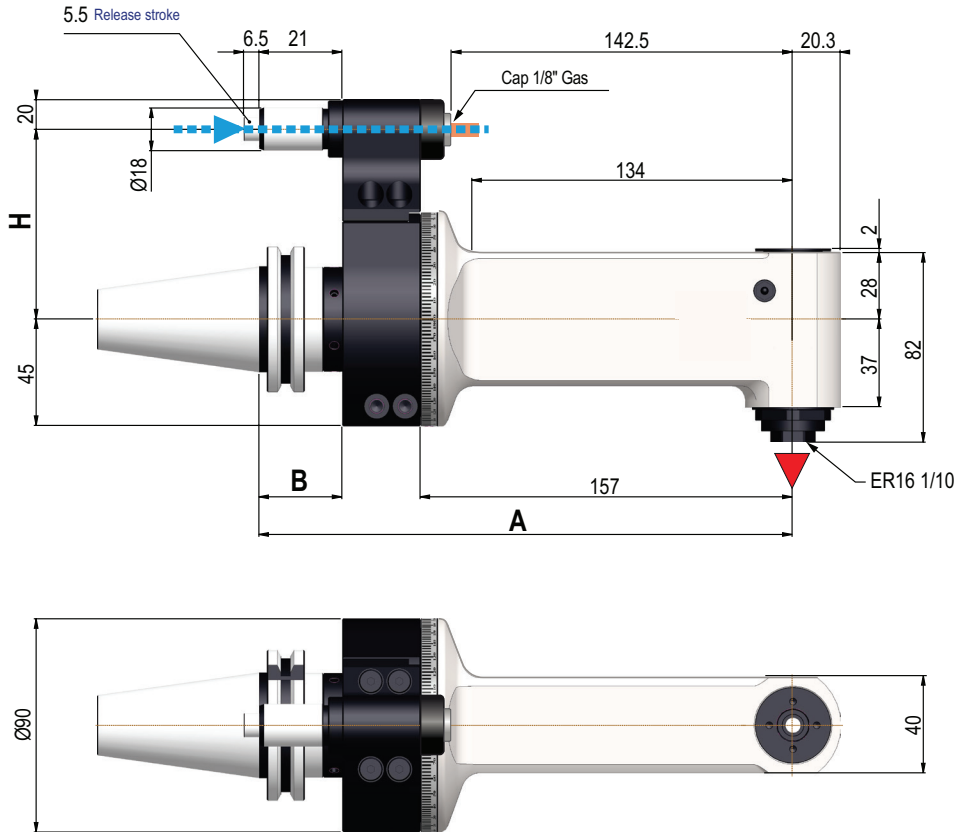

GFX10L ER 16 Long Fixed 90° Right Angle Heads

▼ Direction of rotation is opposite to the machine spindle



Taper	Model	Collet System	A (mm)	B (mm)	H (mm)	End Mill & Drill Cap. (mm)	Tap Size Capacity	Max RPM	Weight (Kg.)	Code No.
CAT40	GFX10L	ER16	225	35	65	10	M8	10,000	5.2	381320S
CAT50	GFX10L	ER16	225	35	80	10	M8	10,000	5.2	381322S
BT40	GFX10L	ER16	225	35	65	10	M8	10,000	5.2	381324S
BT50	GFX10L	ER16	231	41	80	10	M8	10,000	5.2	381326S
HSK63	GFX10L	ER16	232	42	65	10	M8	10,000	5.2	381328S
HSK100	GFX10L	ER16	235	45	80	10	M8	10,000	5.2	381330S

Other tapers available, please inquire.

* For Haas machines please contact Customer Service

Technical Data		GFX10L
Ratio		1:1
RPM Max		10,000
Max axial load	N	250
Torque	Nm	10
Weight	Kg.	5.2
Collet	mm	ER16 1mm-10mm

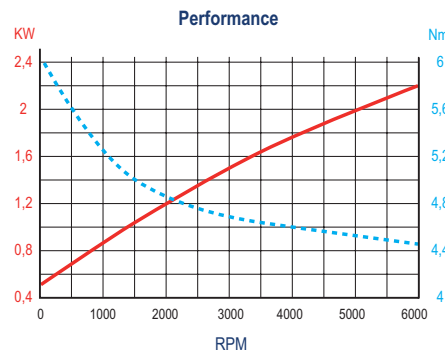

Standard Features & Equipment Included:

- Internal coolant from positioning pin
- Internal air pressure
- Retaining block
- Wrenches
- Grease tube
- Instruction book and Inspection report





ANGLE HEADS

ATC Series

GFX16

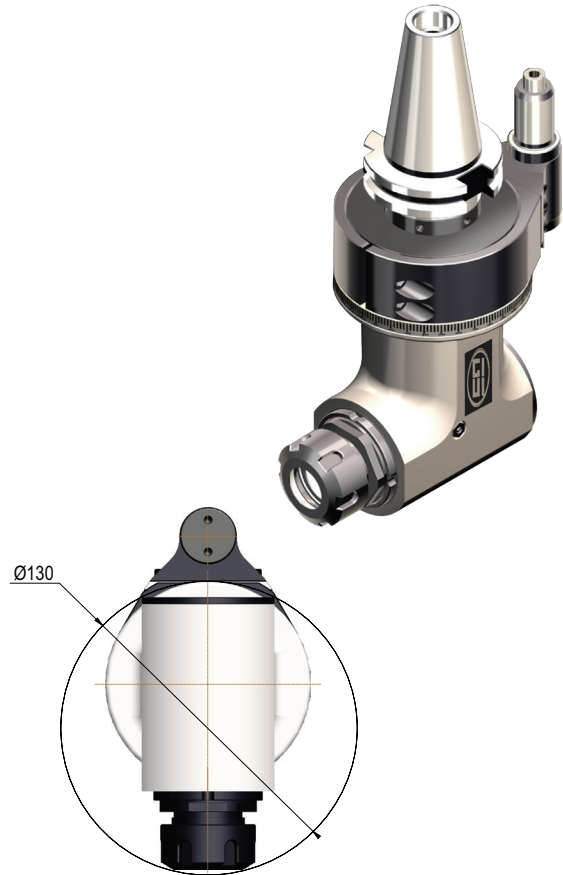
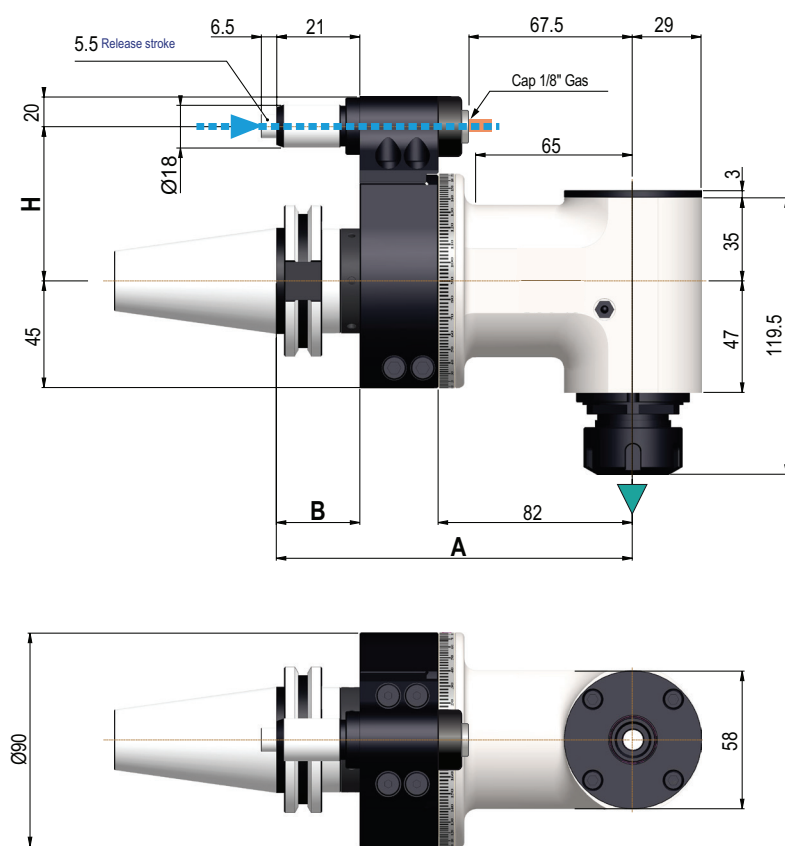

GFX16 ER25 Fixed 90° Right Angle Heads

Direction of rotation is the same as the machine spindle



Taper	Model	System Collet	A (mm)	B (mm)	H (mm)	End Mill & Drill Cap. (mm)	Tap Size Capacity	Max RPM	Weight (Kg.)	Code No.
CAT40	GFX16	ER25	150	35	65	16	M12	8,000	5.4	381100S
CAT50	GFX16	ER25	150	35	80	16	M12	8,000	5.4	381102S
BT40	GFX16	ER25	150	35	65	16	M12	8,000	5.4	381104S
BT50	GFX16	ER25	156	41	80	16	M12	8,000	5.4	381106S
HSK63	GFX16	ER25	157	42	65	16	M12	8,000	5.4	381108S
HSK100	GFX16	ER25	160	45	80	16	M12	8,000	5.4	381110S

Other tapers available, please inquire.
 * For Haas machines please contact Customer Service

Technical Data		GFX16
Ratio		1:1
RPM Max		8,000
Max axial load	N	510
Torque	Nm	24
Weight	Kg.	5.4
Collet	mm	ER25 2mm-16mm

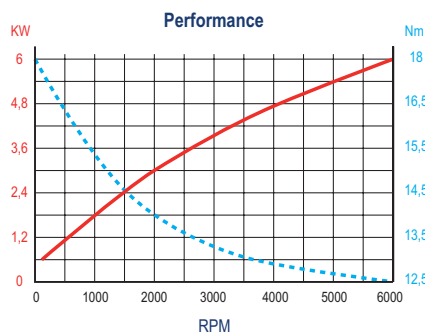

Standard Features & Equipment Included:

- Internal coolant from positioning pin
- Internal air pressure
- Retaining block
- Wrenches
- Grease tube
- Instruction book and Inspection report





ANGLE HEADS

ATC Series

GFX16L

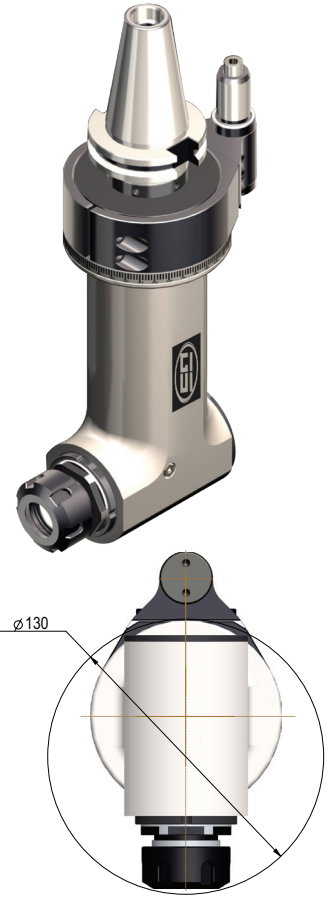
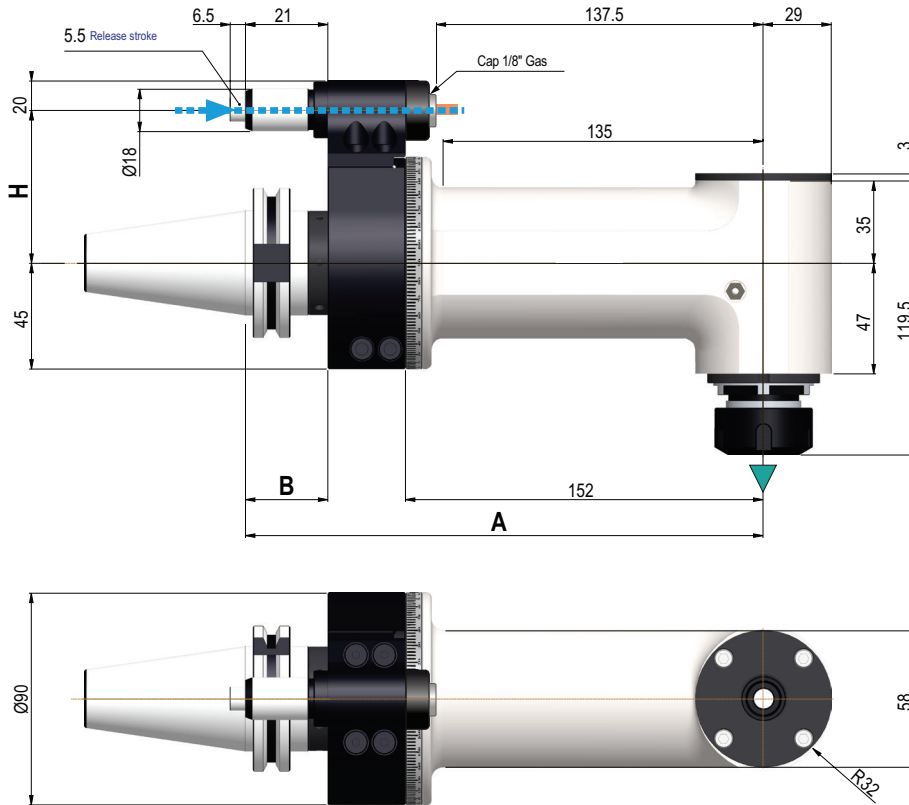

GFX16L ER25 Long Fixed 90° Right Angle Heads

Direction of rotation is the same as the machine spindle



Taper	Model	Collet System	A (mm)	B (mm)	H (mm)	End Mill & Drill Cap. (mm)	Tap Size Capacity	Max RPM	Weight (Kg.)	Code No.
CAT40	GFX16L	ER25	220	35	65	16	M12	8,000	6.7	381400S
CAT50	GFX16L	ER25	220	35	80	16	M12	8,000	6.7	381402S
BT40	GFX16L	ER25	220	35	65	16	M12	8,000	6.7	381404S
BT50	GFX16L	ER25	226	41	80	16	M12	8,000	6.7	381406S
HSK63	GFX16L	ER25	227	42	65	16	M12	8,000	6.7	381408S
HSK100	GFX16L	ER25	230	45	80	16	M12	8,000	6.7	381410S

Other tapers available, please inquire.
 * For Haas machines please contact Customer Service

Technical Data		GFX16L
Ratio		1:1
RPM Max		8,000
Max axial load	N	510
Torque	Nm	24
Weight	Kg.	6.7
Collet	mm	ER25 2mm-16mm

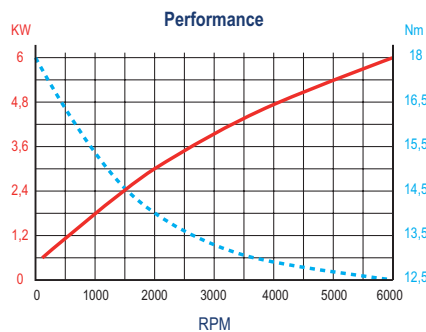

Standard Features & Equipment Included:

- Internal coolant from positioning pin
- Internal air pressure
- Retaining block
- Wrenches
- Grease tube
- Instruction book and Inspection report





ANGLE HEADS

ATC Series

GFX20

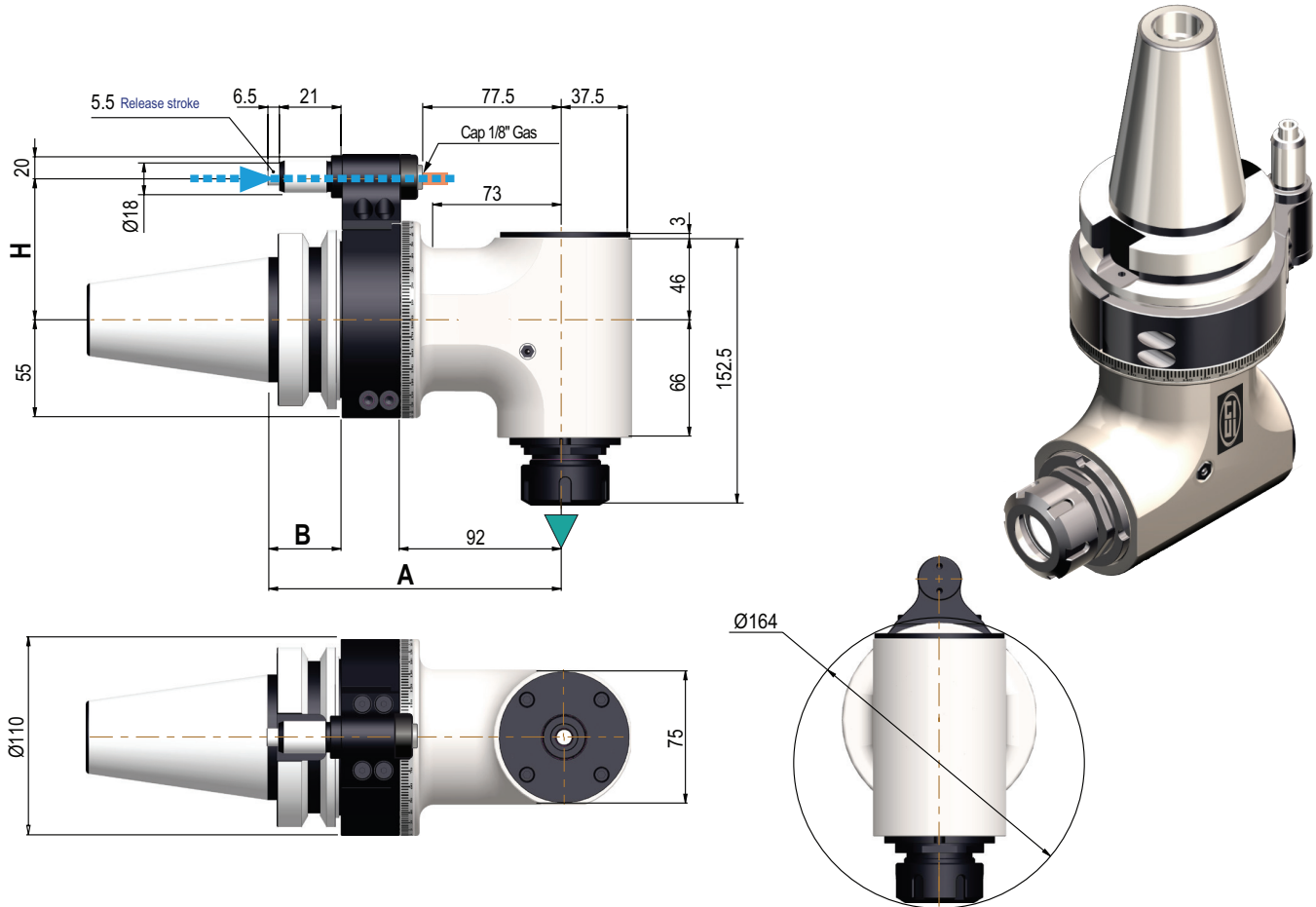

GFX20 ER32 Fixed 90° Right Angle Head

▼ Direction of rotation is the same as the machine spindle



Taper	Model	Collet System	A (mm)	B (mm)	H (mm)	End Mill & Drill Cap. (mm)	Tap Size Capacity	Max RPM	Weight (Kg.)	Code No.
CAT50	GFX20	ER32	160	35	80	20	M16	4,000	11	381148S

Other tapers available, please inquire.
* For Haas machines please contact Customer Service

Technical Data		GFX20
Ratio		1:1
RPM Max		4,000
Max axial load	N	1250
Torque	Nm	40
Weight	Kg.	11
Collet	mm	ER32 2.5mm-20mm

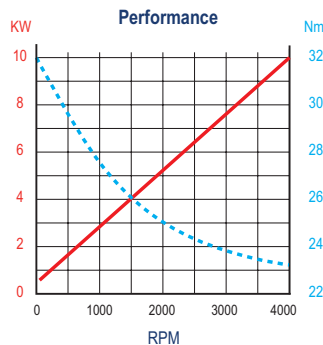

Standard Features & Equipment Included:

- Internal coolant from positioning pin
- Internal air pressure
- Retaining block
- Wrenches
- Grease tube
- Instruction book and Inspection report





ANGLE HEADS

ATC Series

GFX20L

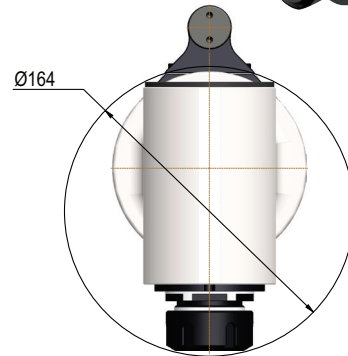
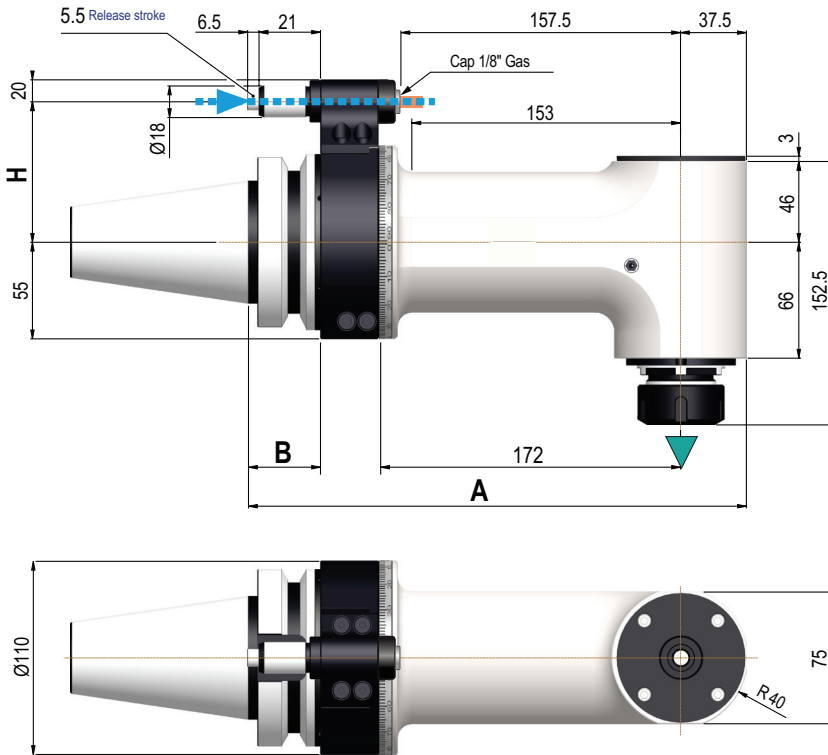

GFX20L ER32 Long Fixed 90° Right Angle Head

Direction of rotation is the same as the machine spindle



Taper	Model	Collet System	A (mm)	B (mm)	H (mm)	End Mill & Drill Cap. (mm)	Tap Size Capacity	Max RPM	Weight (Kg.)	Code No.
CAT50	GFX20L	ER32	240	35	80	20	M16	4,000	13.8	381448S

Other tapers available, please inquire.

* For Haas machines please contact Customer Service

Technical Data		GFX20L
Ratio		1:1
RPM Max		4,000
Max axial load	N	1250
Torque	Nm	40
Weight	Kg.	13.8
Collet	mm	ER32 2.5mm-20mm

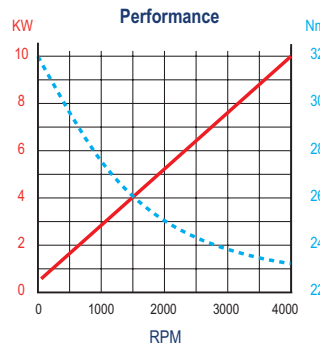

Standard Features & Equipment Included:

- Internal coolant from positioning pin
- Internal air pressure
- Retaining block
- Wrenches
- Grease tube
- Instruction book and Inspection report





ANGLE HEADS

ATC Series

GFXS40

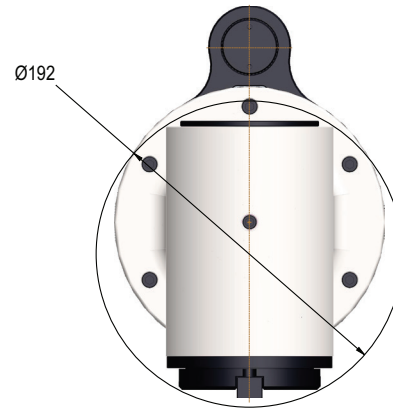
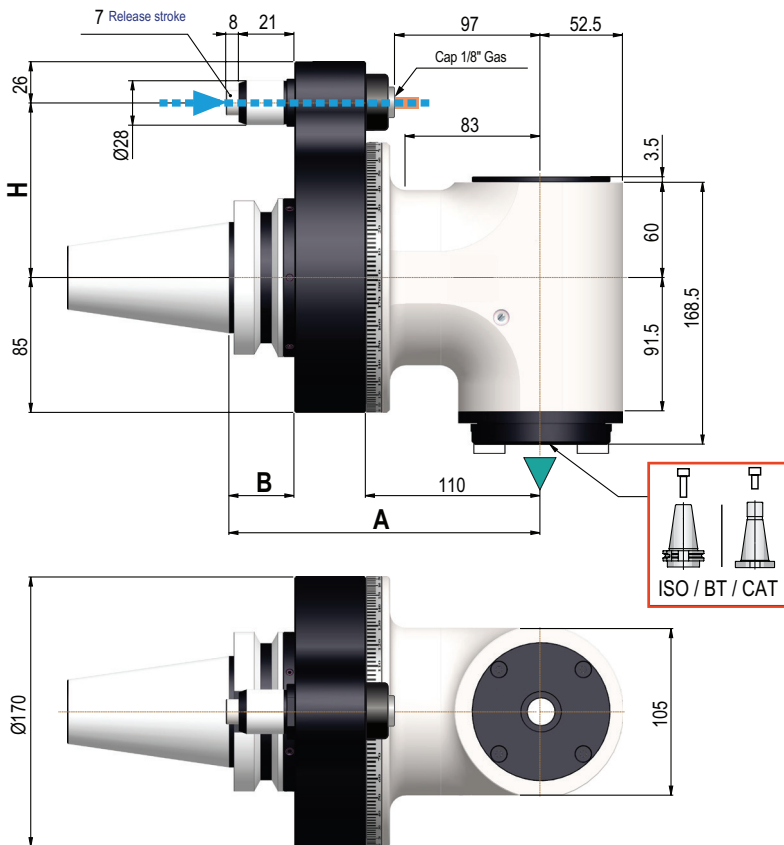

Note: Accepts CAT40, BT40, SK40 and NMTB 40 Taper Tooling

GFX S40 Fixed 90° Right Angle Heads

Direction of rotation is the same as the machine spindle



Taper	Model	A (mm)	B (mm)	H (mm)	End Mill & Drill Cap. (mm)	Tap Size Capacity	Max RPM	Weight (Kg.)	Code No.
CAT50	GFX S40	190	35	110	26	M20	4,000	22	381121S
BT50	GFX S40	196	41	110	26	M20	4,000	22	381123S
HSK100	GFX S40	200	45	110	26	M20	4,000	22	381125S

Other tapers available, please inquire.
* For Haas machines please contact Customer Service

Technical Data		GFX S40
Ratio		1:1
RPM Max		4,000
Max axial load	N	1800
Torque	Nm	140
Weight	Kg.	22
Drill / Tap	mm	26mm/M20

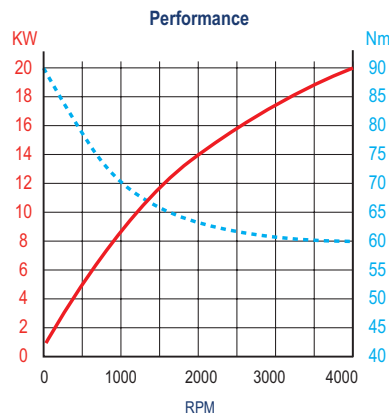

Standard Features & Equipment Included:

- Internal coolant from positioning pin
- Internal air pressure
- Retaining block
- Wrenches
- Grease tube
- Instruction book and Inspection report





ANGLE HEADS

ATC Series

GPV13

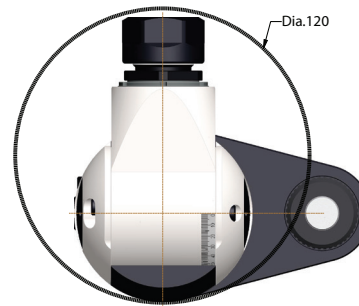
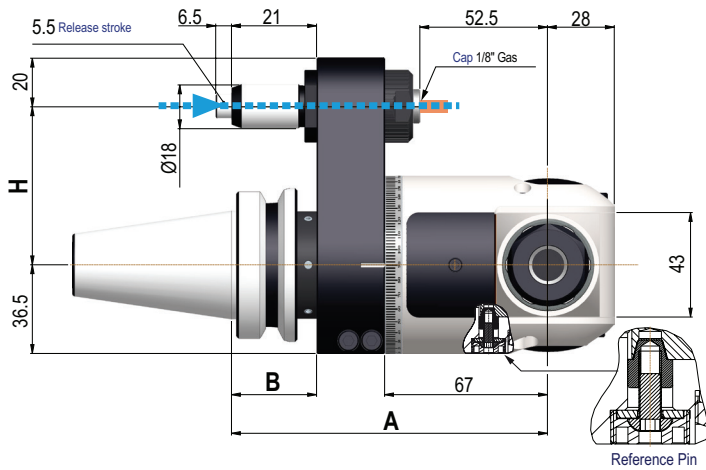
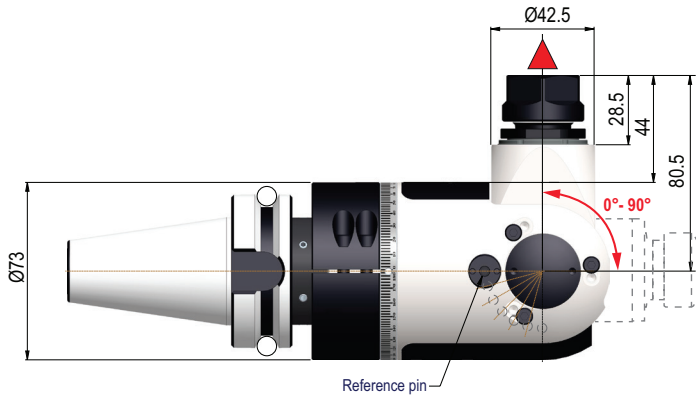

GPV13 ER 20 Pivoting Angle Heads

▼ Direction of rotation is opposite to the machine spindle



Taper	Model	Collet System	A (mm)	B (mm)	H (mm)	End Mill & Drill Cap. (mm)	Tap Size Capacity	Max RPM	Weight (Kg.)	Code No.
CAT40	GPV13	ER20	130	35	65	13	M10	4,000	4.2	381198S
CAT50	GPV13	ER20	130	35	80	13	M10	4,000	4.2	381200S
BT40	GPV13	ER20	130	35	65	13	M10	4,000	4.2	381202S
BT50	GPV13	ER20	136	41	80	13	M10	4,000	4.2	381204S
HSK63	GPV13	ER20	137	42	65	13	M10	4,000	4.2	381206S
HSK100	GPV13	ER20	140	45	80	13	M10	4,000	4.2	381208S

Other tapers available, please inquire.

* For Haas machines please contact Customer Service

Technical Data		GPV13
Ratio		1:1
RPM Max		4,000
Max axial load	N	450
Torque	Nm	6
Weight	Kg.	4.2
Collet	mm	ER20 1mm-13mm

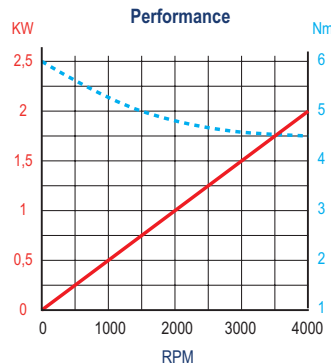

Standard Features & Equipment Included:

- Internal coolant from positioning pin
- Internal air pressure
- Retaining block
- Wrenches
- Grease tube
- Instruction book and Inspection report





ANGLE HEADS

ATC Series

GPV16

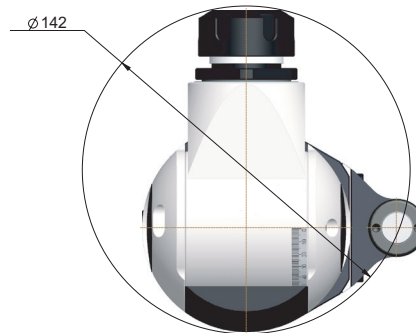
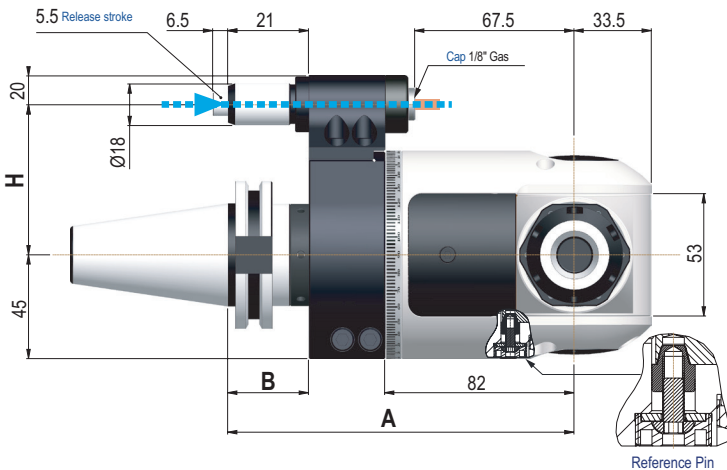
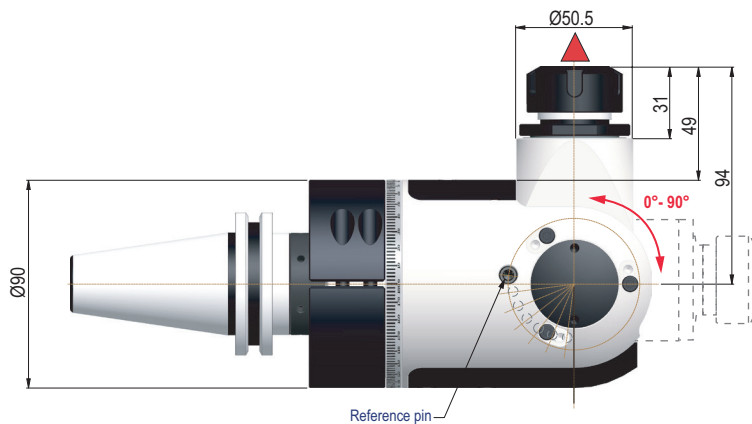

GPV16 ER25 Pivoting Angle Heads

▼ Direction of rotation is opposite to the machine spindle



Taper	Model	Collet System	A (mm)	B (mm)	H (mm)	End Mill & Drill Cap. (mm)	Tap Size Capacity	Max RPM	Weight (Kg.)	Code No.
CAT40	GPV16	ER25	150	35	65	16	M12	4,000	6.8	381270S
CAT50	GPV16	ER25	150	35	80	16	M12	4,000	6.8	381272S
BT40	GPV16	ER25	150	35	65	16	M12	4,000	6.8	381274S
BT50	GPV16	ER25	156	41	80	16	M12	4,000	6.8	381276S
HSK63	GPV16	ER25	157	42	65	16	M12	4,000	6.8	381278S
HSK100	GPV16	ER25	160	45	80	16	M12	4,000	6.8	381280S

Other tapers available, please inquire.
* For Haas machines please contact Customer Service

Technical Data		GPV16
Ratio		1:1
RPM Max		4,000
Max axial load	N	480
Torque	Nm	18
Weight	Kg.	6.8
Collet	mm	ER25 2mm-16mm

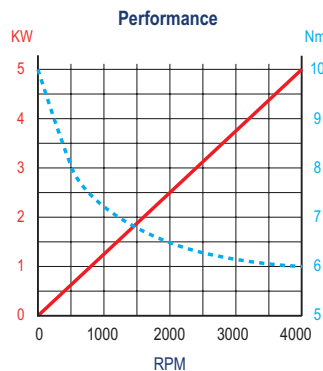

Standard Features & Equipment Included:

- Internal coolant from positioning pin
- Internal air pressure
- Retaining block
- Wrenches
- Grease tube
- Instruction book and Inspection report





ANGLE HEADS

ATC Series

GPV20

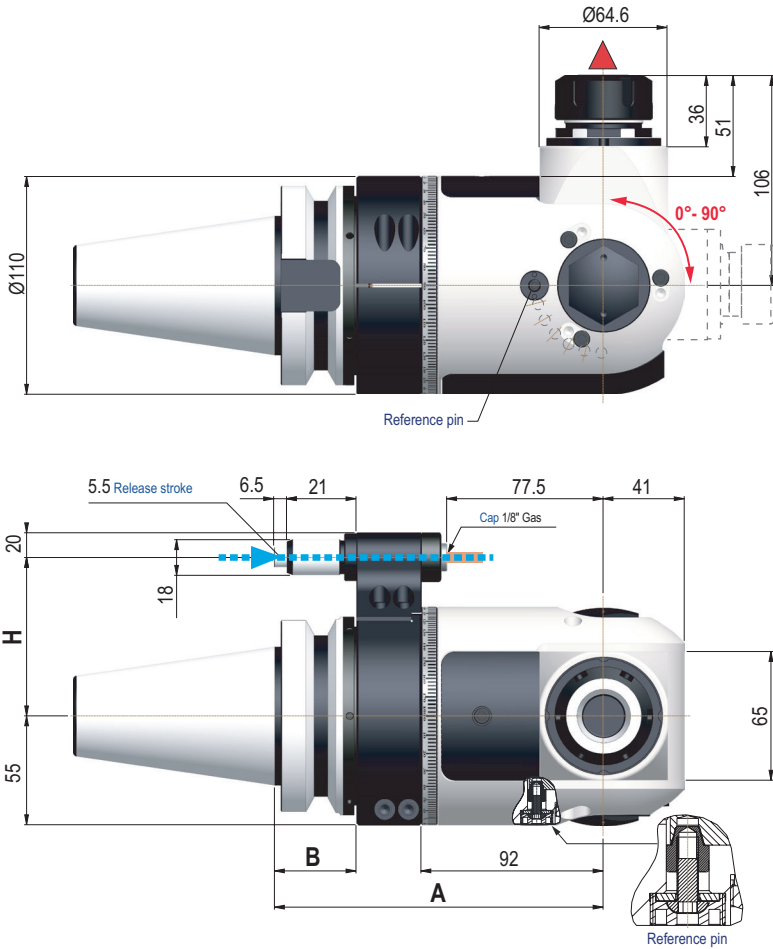

GPV20 ER32 Pivoting Angle Heads

▼ Direction of rotation is opposite to the machine spindle



Taper	Model	Collet System	A (mm)	B (mm)	H (mm)	End Mill & Drill Cap. (mm)	Tap Size Capacity	Max RPM	Weight (Kg.)	Code No.
CAT50	GPV20	ER32	160	35	80	20	M16	4,000	13	381150S
BT50	GPV20	ER32	166	41	80	20	M16	4,000	13	381154S
HSK100	GPV20	ER32	170	45	80	20	M16	4,000	13	381158S

Other tapers available, please inquire.

* For Haas machines please contact Customer Service

Technical Data		GPV20
Ratio		1:1
RPM Max		4,000
Max axial load	N	715
Torque	Nm	32
Weight	Kg.	13
Collet	mm	ER32 3mm-20mm

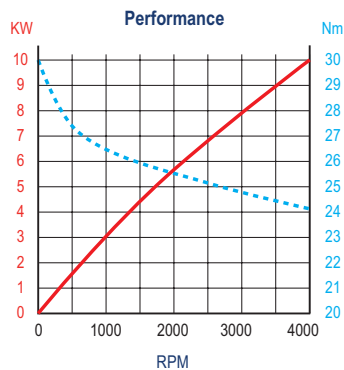

Standard Features & Equipment Included:

- Internal coolant from positioning pin
- Internal air pressure
- Retaining block
- Wrenches
- Grease tube
- Instruction book and Inspection report



Welcome to the **SOWA** family!



Superior performance tool holding and workholding solutions when speed and accuracy matter most.

ASIMETO

High-performance precision measuring and inspecting solutions.



High-performance cutting tools including end mills, drills, taps and indexables.

SKODA

High Value production grade live centers.

narex

Exclusive line of value boring heads.



A wide product range of economic tooling for general purpose applications.



With this line-up, Sowa Tool is uniquely qualified to serve all your needs under one roof. Ask us how Sowa can tool your world and provide the competitive edge for your business.

Distributed by:



COMPLETE METALWORKING SOLUTIONS

(800) 991-4225

www.ahbinc.com

ISO Certified

customerservice@ahbinc.com

SOWA
TOOLING YOUR WORLD.

Sowa Tool & Machine Co. Ltd.

Canadian Head Office
500 Manitou Drive, Kitchener, ON, N2C 1L3
North Carolina Office
101-137 Overhill Drive, Mooresville, NC 28117

TF: 1-800-265-8221
Tel: 519-748-5750
Fax: 519-748-9304
sales@sowatool.com
www.SowaTool.com