

SOWA

TOOLING
YOUR
WORLD.

AHB
TOOLING & MACHINERY

COMPLETE METALWORKING SOLUTIONS

(800) 991-4225

www.ahbinc.com

ISO Certified

customerservice@ahbinc.com



End Mill Holders & Shell Mill Holders



CAT40 End Mill Holders	4-5
CAT50 End Mill Holders	6-7
BT End Mill Holders	7-8
HSK & NMTB End Mill Holders	9
Accessories	10 & 14
Retention Knobs	11
Shell Mill & Face Mill Holders	12-13

Sowa Tool has been serving the metalworking industry since 1960.

Your world is full of challenges and worrying about having the right tools for the job should not be one of them. With a three-generation legacy of family-style customer service, Sowa Tool & Machine has been trusted by manufacturers and distributors throughout North America to supply some of the industry's best metalworking solutions since 1960.

Our mission has been and continues to be to provide the broadest range of metalworking solutions in the industry. We accomplish this through the continuous development of our family of brands that include items within the Tool Holding, Workholding, Measuring & Inspecting, and Cutting Tool categories. This allows you to secure all these solutions from one place, reducing your total number of purchase orders and consolidating your freight charges in this increasingly expensive market.

Our wide array of metalworking products come in stock with same-day shipping if ordered before 3:00 pm EST. Our customer service team is just a call or click away, available to offer technical help or source hard-to-find products. Over the decades we've fine-tuned the balance between inventory, pricing and customer service, and can help you select precisely what you need to get the job done right. Our manufactured products are designed to meet the highest quality standards or provide the best price on the market, sometimes both!

26,000+

INDUSTRIAL PRODUCTS

6

INDUSTRY BRANDS

1960

YEAR FOUNDED

5

WAREHOUSES

90+

ASSOCIATES

23,000+

STOCKED SKU'S IN THE USA



**Depend on us to tool your world and deliver
the competitive edge your business needs to stay ahead!**

SOWA NOW HAS TWO HOLDER OPTIONS:



Which one works best for your application?

NEW

STM PREMIUM

The perfect economic tooling solution for general purpose machining applications.

VS

GS TOOLING

Superior tooling performance when speed and accuracy matter most.

42CrMo	Material Grade	16NiCr4 (Premium European Alloy Steel)
AT3 or better (0.00024-0.00036in/ft)	Taper Accuracy	AT2 or better (0.00012-0.00024in/ft)
0.0002"	Runout Accuracy	0.0001"
CAT40 End Mill Holders: Balanced to G2.5 / 8,000rpm CAT50 End Mill Holders: Balanced to G2.5 / 6,000rpm	Balance	CAT40 End Mill Holders: Balanced to G6.3 / 30,000rpm CAT50 End Mill Holders: Balanced to G6.3 / 25,000rpm
CAT40 Collet Chucks: Balanced to G2.5 / 20,000rpm CAT50 Collet Chucks: Balanced to G2.5 / 15,000rpm	Coolant Features	CAT40 Collet Chucks: Balanced to G2.5 / 30,000rpm CAT50 Collet Chucks: Balanced to G2.5 / 25,000rpm
AD/B DIN coolant through flange	Thread Tolerance	H4 = basic plus 0.0015-0.0020" (premium class of fit)
H6 = basic plus 0.0025-0.0030" (standard class of fit)	SKU Offering	Wide selection
Limited to the most popular items		

End Mill Holders & Shell Mill Holders

CAT40 End Mill Holders



- DIN coolant option - standard
- All ground body, bore, nose, flange
- TIR, 0.0001" / 0.003mm OD to ID
- Certified Steel
- AT2 Taper Accuracy
- RFID chip hole

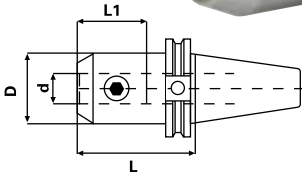

PREMIUM BALANCE
G6.3 at 30,000rpm
CERTIFICATE INCLUDED

Taper	Hole Dia. (d)	Gauge Length (L)	L1	D	Set Screw	Code No.
CT40	1/8	1.35*	0.59	0.75	8-32	531069
CT40	1/8	2.50	0.59	0.75	8-32	531070
CT40	1/8	4.00	0.59	0.75	8-32	531071
CT40	3/16	1.38*	0.79	0.75	10-32	531072
CT40	3/16	2.50	0.79	0.75	10-32	531073
CT40	3/16	4.00	0.79	0.75	10-32	531074
CT40	1/4	1.38*	1.18	0.79	1/4-28	531000
CT40	1/4	2.50	1.18	0.79	1/4-28	531002
CT40	1/4	4.00	1.18	0.79	1/4-28	531004
CT40	1/4	9.00	1.18	0.79	1/4-28	531005
CT40	5/16	1.38*	1.18	0.87	5/16-24	531006
CT40	5/16	2.50	1.18	0.87	5/16-24	531008
CT40	5/16	4.00	1.18	0.87	5/16-24	531010
CT40	5/16	9.00	1.18	0.87	5/16-24	531011
CT40	3/8	1.38*	1.57	1.00	3/8-24	531012
CT40	3/8	2.50	1.57	1.00	3/8-24	531014
CT40	3/8	4.00	1.57	1.00	3/8-24	531016
CT40	3/8	5.00	1.57	1.00	3/8-24	531018
CT40	3/8	9.00	1.57	1.00	3/8-24	531031
CT40	7/16	2.50	1.50	1.38	7/16-20	531020
CT40	7/16	4.00	1.50	1.38	7/16-20	531022
CT40	7/16	9.00	1.50	1.38	7/16-20	531033
CT40	1/2	1.75*	2.56	1.38	7/16-20	531024
CT40	1/2	2.50	2.56	1.38	7/16-20	531026
CT40	1/2	4.00	2.56	1.38	7/16-20	531028
CT40	1/2	5.00	3.07	1.38	7/16-20	531030
CT40	1/2	9.00	2.56	1.38	7/16-20	531035
CT40	5/8	1.75*	1.97	1.65	9/16-18	531032
CT40	5/8	3.00	2.76	1.65	9/16-18	531034
CT40	5/8	4.00	2.76	1.65	9/16-18	531036
CT40	5/8	5.50	2.76	1.65	9/16-18	531038
CT40	5/8	9.00	3.50	1.65	9/16-18	531037
CT40	3/4	1.75*	2.01	1.89	5/8-18	531040
CT40	3/4	3.00	2.56	1.75	5/8-18	531042
CT40	3/4	4.00	2.56	1.75	5/8-18	531044
CT40	3/4	5.50	2.56	1.75	5/8-18	531046
CT40	3/4	9.00	3.86	1.75	5/8-18	531039
CT40	7/8	1.75*	2.17	1.94	5/8-18	531048
CT40	7/8	3.50	3.15	2.00	5/8-18	531050
CT40	7/8	6.00	4.22	2.00	5/8-18	531052
CT40	7/8	9.00	4.22	2.00	5/8-18	531041
CT40	1	2.00*	2.32	2.25	3/4-16	531054
CT40	1	4.00	3.54	2.36	3/4-16	531056
CT40	1	6.00	3.54	2.36	3/4-16	531058
CT40	1	9.00	4.50	2.36	3/4-16	531043
CT40	1-1/4	2.00*	2.44	2.25	3/4-16	531060‡
CT40	1-1/4	4.00	3.54	2.48	3/4-16	531062
CT40	1-1/4	6.00	3.54	2.48	3/4-16	531064
CT40	1-1/2	4.50	2.95	2.99	3/4-16	531066
CT40	1-1/2	6.00	3.20	2.99	3/4-16	531068

* Stubby Length

‡ Not DIN Coolant

STM CAT40 End Mill Holders



- DIN coolant option - standard
- Factory balanced to save spindle life, tool life and increased productivity
- Threaded through holes for a back-up screw (tool stop) or coolant through when removed
- TIR, 0.0002" OD to ID
- RFID chip hole

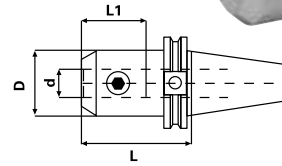

BALANCE CERTIFICATE
G2.5 at 8,000rpm
INCLUDED

Taper	Hole Dia. (d)	Gauge Length (L)	L1	D	Set Screw	Code No.
CT40	1/8	2.50	0.63	0.75	8-32	525070
CT40	1/8	4.00	0.63	0.75	8-32	525071
CT40	3/16	2.50	0.86	0.75	10-32	525073
CT40	3/16	4.00	0.86	0.75	10-32	525074
CT40	1/4	2.50	1.10	0.79	1/4-28	525002
CT40	1/4	4.00	1.10	0.79	1/4-28	525004
CT40	5/16	2.50	1.26	0.87	5/16-24	525008
CT40	3/8	2.50	1.26	1.00	3/8-24	525014
CT40	3/8	4.00	1.26	1.00	3/8-24	525016
CT40	1/2	1.75*	1.50	1.38	7/16-20	525024
CT40	1/2	2.50	1.50	1.38	7/16-20	525026
CT40	1/2	4.00	1.50	1.38	7/16-20	525028
CT40	5/8	1.75*	1.61	1.65	9/16-18	525032
CT40	5/8	3.00	1.61	1.65	9/16-18	525034
CT40	3/4	1.75*	1.77	1.89	5/8-18	525040
CT40	3/4	3.00	1.77	1.75	5/8-18	525042
CT40	1	2.00*	2.36	2.25	3/4-16	525054
CT40	1	4.00	2.36	2.36	3/4-16	525056
CT40	1-1/4	2.00*	2.28	2.25	3/4-16	525060‡

* Stubby Length

‡ Not DIN Coolant

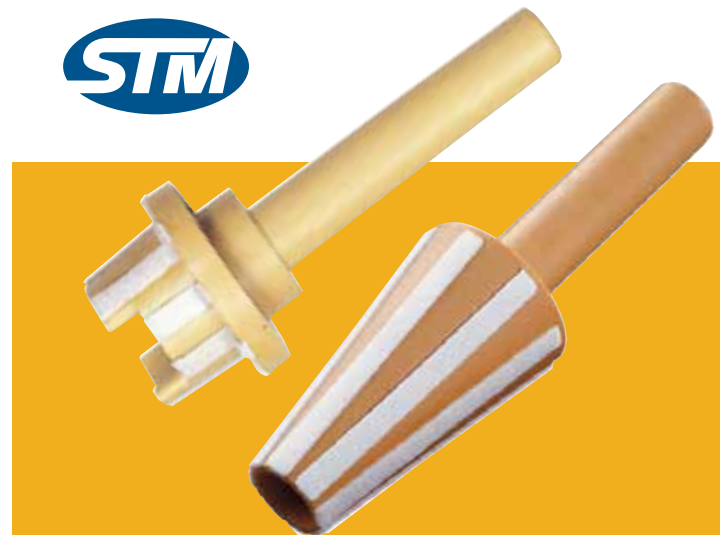

CAT40 DUAL CONTACT End Mill Holders



- Improves rigidity and reduces vibration allowing for increased feed rates and increased tool life
- DIN coolant option - standard
- All ground body, bore, nose, flange
- TIR, 0.0001" / 0.003mm OD to ID
- AT2 Taper Accuracy
- Certified Steel
- RFID chip hole

FOR DUAL CONTACT SPINDLES

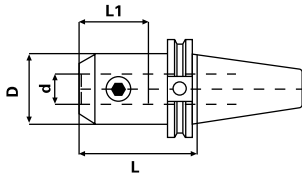
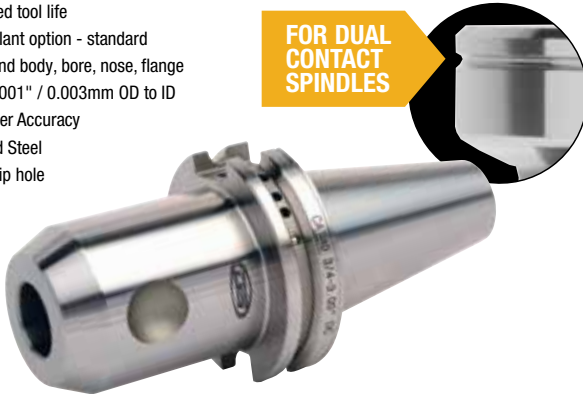

PREMIUM BALANCE
G6.3 at 30,000rpm
CERTIFICATE INCLUDED

Taper	Hole Dia. (d)	Gauge Length (L)	L1	D	Set Screw	Code No.
CT40	1/2	2.50	2.56	1.38	7/16-20	521026
CT40	1/2	4.00	2.56	1.38	7/16-20	521028
CT40	1/2	5.00	2.56	1.38	7/16-20	521030
CT40	5/8	3.00	3.50	1.65	9/16-18	521034
CT40	5/8	4.00	3.50	1.65	9/16-18	521036
CT40	5/8	5.50	3.50	1.65	9/16-18	521038
CT40	3/4	3.00	3.86	1.75	5/8-18	521042
CT40	3/4	4.00	3.86	1.75	5/8-18	521044
CT40	3/4	5.50	3.86	1.75	5/8-18	521046
CT40	1	2.00	2.36	2.36	3/4-16	521054
CT40	1	4.00	4.21	2.36	3/4-16	521056
CT40	1	6.00	4.21	2.36	3/4-16	521058
CT40	1-1/4	2.00*	2.36	2.25	3/4-16	521060‡
CT40	1-1/4	4.00	3.54	2.48	3/4-16	521062
CT40	1-1/4	6.00	3.54	2.48	3/4-16	521064
CT40	1-1/2	4.50	2.95	2.99	3/4-16	521066

* Stubby Length

‡ Not DIN Coolant

CAT40 DIRECT COOLANT End Mill Holders



NOW 3 COOLANT OPTIONS ALL IN ONE!

- Coolant through the spindle and body
- DIN coolant through flange option
- All ground body, bore, nose, flange
- Certified Steel
- TIR, 0.0001" / 0.003mm OD to ID
- AT2 Taper Accuracy
- RFID chip hole

DIRECT COOLANT

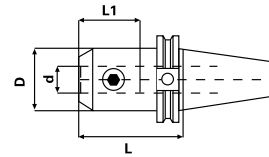
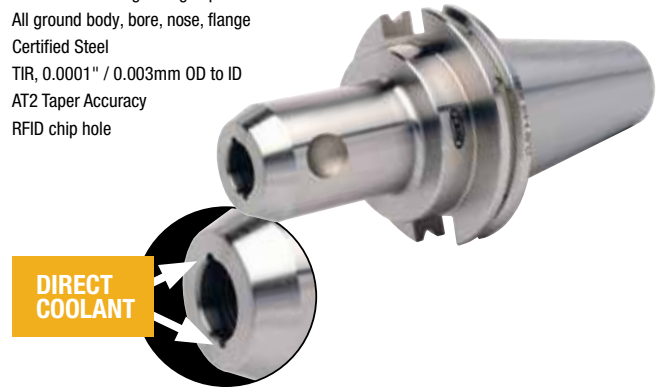

PREMIUM BALANCE
G6.3 at 30,000rpm
CERTIFICATE INCLUDED

Taper	Hole Dia. (d)	Gauge Length (L)	L1	D	Set Screw	Code No.
CT40	1/4	1.38*	1.18	0.79	1/4-28	522014
CT40	1/4	2.50	1.18	0.79	1/4-28	522016
CT40	1/4	4.00	1.18	0.79	1/4-28	522018
CT40	5/16	1.38*	1.18	0.87	5/16-24	522022
CT40	5/16	2.50	1.18	0.87	5/16-24	522024
CT40	5/16	4.00	1.18	0.87	5/16-24	522026
CT40	3/8	1.38*	1.57	1.00	3/8-24	522030
CT40	3/8	2.50	1.57	1.00	3/8-24	522032
CT40	3/8	4.00	1.57	1.00	3/8-24	522034
CT40	3/8	5.00	1.57	1.00	3/8-24	522036
CT40	1/2	1.75*	2.56	1.38	7/16-20	522046
CT40	1/2	2.50	2.56	1.38	7/16-20	522048
CT40	1/2	4.00	2.56	1.38	7/16-20	522050
CT40	1/2	5.00	2.56	1.38	7/16-20	522052
CT40	5/8	1.75*	2.72	1.65	9/16-18	522056
CT40	5/8	3.00	2.56	1.65	9/16-18	522058
CT40	5/8	4.00	2.56	1.65	9/16-18	522060
CT40	3/4	1.75*	2.56	1.89	5/8-18	522066
CT40	3/4	3.00	2.56	1.75	5/8-18	522068
CT40	3/4	4.00	2.56	1.75	5/8-18	522070
CT40	3/4	5.50	2.56	1.75	5/8-18	522072
CT40	1	2.00*	2.36	2.25	3/4-16	522080
CT40	1	4.00	3.54	2.36	3/4-16	522082
CT40	1-1/4	2.00*	2.44	2.25	3/4-16	522088
CT40	1-1/4	4.00	3.54	2.48	3/4-16	522090
CT40	1-1/2	4.50	2.95	2.99	3/4-16	522094

* Stubby Length

Spindle Taper Wipers
Clean spindle holes easily
and quickly!

See www.SowaTool.com

End Mill Holders & Shell Mill Holders

CAT50 End Mill Holders



- DIN coolant option - standard
- All ground body, bore, nose, flange
- TIR, 0.0001" / 0.003mm OD to ID
- AT2 Taper Accuracy
- Certified Steel
- RFID chip hole

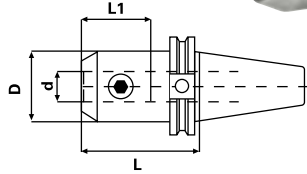

PREMIUM BALANCE
G6.3 at 25,000rpm
CERTIFICATE INCLUDED

Taper	Hole Dia. (d)	Gauge Length (L)	L1	D	Set Screw	Code No.
CT50	1/4	1.38*	0.71	0.79	1/4-28	531082
CT50	1/4	2.50	1.18	0.79	1/4-28	531084
CT50	1/4	4.00	1.18	0.79	1/4-28	531086
CT50	1/4	6.00	1.18	0.79	1/4-28	531088
CT50	1/4	8.00	1.18	0.79	1/4-28	531090
CT50	5/16	2.50	1.18	0.87	5/16-24	531092
CT50	5/16	4.00	1.18	0.87	5/16-24	531094
CT50	5/16	6.00	1.18	0.87	5/16-24	531096
CT50	3/8	1.38*	1.57	1.00	3/8-24	531098
CT50	3/8	2.50	1.57	1.00	3/8-24	531100
CT50	3/8	4.00	1.57	1.00	3/8-24	531102
CT50	3/8	6.00	1.57	1.00	3/8-24	531104
CT50	3/8	8.00	1.57	1.00	3/8-24	531106
CT50	3/8	14.00	1.57	1.00	3/8-24	531107
CT50	7/16	2.50	1.50	1.38	7/16-20	531108
CT50	7/16	4.00	1.50	1.38	7/16-20	531110
CT50	7/16	6.00	1.50	1.38	7/16-20	531112
CT50	7/16	14.00	1.48	1.38	7/16-20	531113
CT50	1/2	1.75*	1.50	1.38	7/16-20	531116
CT50	1/2	2.63	1.77	1.38	7/16-20	531118
CT50	1/2	4.00	1.77	1.38	7/16-20	531120
CT50	1/2	6.00	1.77	1.38	7/16-20	531122
CT50	1/2	8.00	1.77	1.38	7/16-20	531124
CT50	1/2	14.00	1.77	1.38	7/16-20	531125
CT50	9/16	6.00	1.77	1.65	9/16-18	531133
CT50	5/8	1.75*	1.73	1.65	9/16-18	531126
CT50	5/8	3.00	1.77	1.65	9/16-18	531128
CT50	5/8	4.00	1.77	1.65	9/16-18	531130
CT50	5/8	6.00	1.77	1.65	9/16-18	531132
CT50	5/8	8.00	1.77	1.65	9/16-18	531134
CT50	5/8	14.00	1.57	1.65	9/16-18	531131
CT50	3/4	1.75*	2.76	1.89	5/8-18	531136
CT50	3/4	3.00	2.76	1.89	5/8-18	531138
CT50	3/4	4.00	2.76	1.89	5/8-18	531140
CT50	3/4	6.00	2.76	1.89	5/8-18	531142
CT50	3/4	8.00	2.76	1.89	5/8-18	531144
CT50	3/4	14.00	3.86	1.89	5/8-18	531145
CT50	7/8	1.75*	3.15	2.00	5/8-18	531146
CT50	7/8	3.75	3.15	2.00	5/8-18	531148
CT50	1	2.00*	2.32	2.36	3/4-16	531152
CT50	1	4.00	3.54	2.36	3/4-16	531154
CT50	1	6.00	3.54	2.36	3/4-16	531156
CT50	1	8.00	3.54	2.36	3/4-16	531158
CT50	1-1/4	2.00*	2.56	2.75	3/4-16	531160
CT50	1-1/4	4.00	3.54	2.48	3/4-16	531162
CT50	1-1/4	6.00	3.54	2.48	3/4-16	531164
CT50	1-1/4	8.00	3.54	2.48	3/4-16	531166
CT50	1-1/2	2.25*	2.83	2.75	3/4-16	531168
CT50	1-1/2	4.50	3.15	2.99	3/4-16	531170
CT50	1-1/2	7.00	3.15	2.99	3/4-16	531172
CT50	1-1/2	9.00	3.15	2.99	3/4-16	531174
CT50	2	3.63*	3.66	3.74	1-14	531176
CT50	2	5.37	4.13	3.74	1-14	531178
CT50	2	8.00	4.13	3.74	1-14	531180
CT50	2	10.00	4.13	3.74	1-14	531182
CT50	2-1/2	6.00	3.94	4.25	1-14	531184

* Stubby Length

STM CAT50 End Mill Holders



- DIN coolant option - standard
- Factory balanced to save spindle life, tool life and increased productivity
- Threaded through holes for a back-up screw (tool stop) or coolant through when removed
- TIR, 0.0002" OD to ID
- RFID chip hole

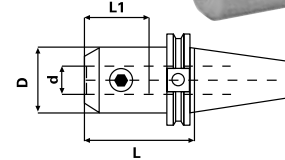
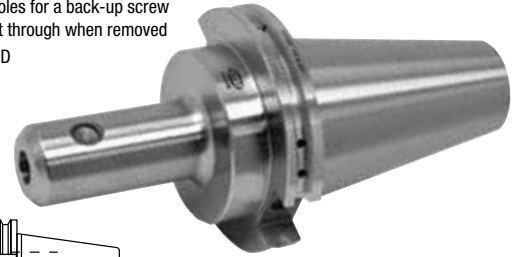

BALANCE CERTIFICATE
G2.5 at 6,000rpm
INCLUDED

Taper	Hole Dia. (d)	Gauge Length (L)	L1	D	Set Screw	Code No.
CT50	1/2	4.00	1.50	1.38	7/16-20	525120
CT50	3/4	4.00	1.77	1.89	5/8-18	525140
CT50	1	4.00	2.36	2.36	3/4-16	525154
CT50	1-1/4	4.00	2.55	2.48	3/4-16	525162

CAT50 DUAL CONTACT End Mill Holders



- Improves rigidity and reduces vibration allowing for increased feed rates and increased tool life
- DIN coolant option - standard
- All ground body, bore, nose, flange
- TIR, 0.0001" / 0.003mm OD to ID
- AT2 Taper Accuracy
- Certified Steel
- RFID chip hole

FOR DUAL CONTACT SPINDLES

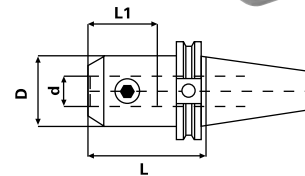
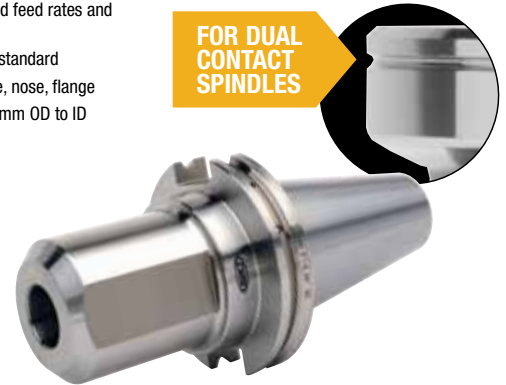

PREMIUM BALANCE
G6.3 at 25,000rpm
CERTIFICATE INCLUDED

Taper	Hole Dia. (d)	Gauge Length (L)	L1	D	Set Screw	Code No.
CT50	1/2	4.00	1.77	1.38	7/16-20	521120
CT50	1/2	6.00	1.77	1.38	7/16-20	521122
CT50	5/8	4.00	1.77	1.65	9/16-18	521130
CT50	5/8	6.00	1.77	1.65	9/16-18	521132
CT50	3/4	3.00	3.86	1.89	5/8-18	521138
CT50	3/4	4.00	3.86	1.89	5/8-18	521140
CT50	3/4	6.00	3.86	1.89	5/8-18	521142
CT50	1	4.00	4.21	2.36	3/4-16	521154
CT50	1	6.00	4.21	2.36	3/4-16	521156
CT50	1	8.00	4.21	2.36	3/4-16	521158
CT50	1-1/4	4.00	3.54	2.48	3/4-16	521162
CT50	1-1/4	6.00	3.54	2.48	3/4-16	521164
CT50	1-1/4	8.00	3.54	2.48	3/4-16	521166
CT50	1-1/2	4.50	3.15	2.99	3/4-16	521170
CT50	1-1/2	7.00	3.15	2.99	3/4-16	521172
CT50	2	5.37	4.13	3.74	1-14	521178

CAT50 DIRECT COOLANT End Mill Holders



NOW 3 COOLANT OPTIONS ALL IN ONE!

- Coolant through the spindle
- DIN coolant through flange option
- Coolant through the body
- All ground body, bore, nose, flange
- TIR, 0.0001" / 0.003mm OD to ID
- AT2 Taper Accuracy
- Certified Steel
- RFID chip hole



DIRECT COOLANT

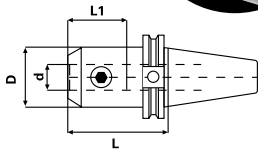

PREMIUM BALANCE
G6.3 at 25,000rpm
CERTIFICATE INCLUDED

Taper	Hole Dia. (d)	Gauge Length (L)	L1	D	Set Screw	Code No.
CT50	1/4	2.50	1.18	0.79	1/4-28	522102
CT50	1/4	4.00	1.18	0.79	1/4-28	522104
CT50	5/16	4.00	1.26	0.87	5/16-24	522112
CT50	3/8	2.50	1.57	1.00	3/8-24	522118
CT50	3/8	4.00	1.57	1.00	3/8-24	522120
CT50	3/8	6.00	1.57	1.00	3/8-24	522122
CT50	3/8	8.00	1.26	1.00	3/8-24	522124
CT50	7/16	4.00	1.50	1.38	7/16-20	522130
CT50	1/2	1.75*	1.50	1.38	7/16-20	522134
CT50	1/2	2.63	1.77	1.38	7/16-20	522136
CT50	1/2	4.00	1.77	1.38	7/16-20	522138
CT50	1/2	6.00	1.77	1.38	7/16-20	522140
CT50	1/2	8.00	1.48	1.38	7/16-20	522142
CT50	5/8	1.75*	1.77	1.65	9/16-18	522148
CT50	5/8	3.00	1.77	1.65	9/16-18	522150
CT50	5/8	4.00	1.77	1.65	9/16-18	522152
CT50	5/8	6.00	1.61	1.65	9/16-18	522154
CT50	3/4	1.75*	2.76	1.89	5/8-18	522158
CT50	3/4	3.00	2.76	1.89	5/8-18	522160
CT50	3/4	4.00	2.76	1.89	5/8-18	522162
CT50	3/4	6.00	2.76	1.89	5/8-18	522164
CT50	3/4	8.00	2.76	1.89	5/8-18	522166
CT50	1	2.00*	2.32	2.36	3/4-16	522176
CT50	1	4.00	3.54	2.36	3/4-16	522178
CT50	1	6.00	3.54	2.36	3/4-16	522180
CT50	1	8.00	3.54	2.36	3/4-16	522182
CT50	1	12.00	2.36	2.36	3/4-16	522183
CT50	1-1/4	2.00*	2.56	2.75	3/4-16	522186
CT50	1-1/4	4.00	3.54	2.48	3/4-16	522188
CT50	1-1/4	6.00	3.54	2.48	3/4-16	522190
CT50	1-1/2	2.25*	2.83	2.75	3/4-16	522196
CT50	1-1/2	4.50	3.15	2.99	3/4-16	522198
CT50	2	3.63*	3.66	3.74	1-14	522204
CT50	2	5.37	4.13	3.74	1-14	522206
CT50	2	8.00	4.13	3.74	1-14	522208
CT50	2	10.00	4.13	3.74	1-14	522210

* Stubby Length

BT30 End Mill Holders



- All ground body, bore, nose, flange
- TIR, 0.0001" / 0.003mm OD to ID
- AT2 Taper Accuracy
- Certified Steel
- RFID chip hole

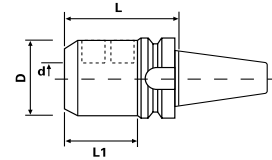

PREMIUM BALANCE
G6.3 at 30,000rpm
CERTIFICATE INCLUDED

Taper	Hole Dia. (d)	Gauge Length (L)	L1	D	Set Screw	Code No.
BT30	1/8	2.36	0.59	0.75	8-32	532001
BT30	3/16	2.36	0.79	0.75	10-32	532003
BT30	1/4	2.36	1.18	0.79	1/4-28	532000
BT30	5/16	2.36	1.18	0.87	5/16-24	532002
BT30	3/8	2.36	1.18	1.00	3/8-24	532004
BT30	7/16	2.36	1.50	1.38	7/16-20	532006
BT30	1/2	2.36	2.95	1.38	7/16-20	532008
BT30	5/8	2.50	1.61	1.65	9/16-18	532010
BT30	3/4	3.00	1.77	1.88	5/8-18	532012
BT30	7/8	3.54	2.09	2.00	5/8-18	532014
BT30	1	3.54	2.32	2.36	3/4-16	532016

BT30 DIRECT COOLANT End Mill Holders



NOW 2 COOLANT OPTIONS ALL IN ONE!

- Coolant through the spindle
- Coolant through the body
- All ground body, bore, nose, flange
- TIR, 0.0001" / 0.003mm OD to ID
- AT2 Taper Accuracy
- Certified Steel
- RFID chip hole



DIRECT COOLANT

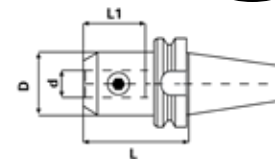

PREMIUM BALANCE
G6.3 at 30,000rpm
CERTIFICATE INCLUDED

Taper	Hole Dia. (d)	Gauge Length (L)	L1	D	Set Screw	Code No.
BT30	1/4	2.36	1.10	0.79	1/4-28	522218
BT30	5/16	2.36	1.26	0.87	5/16-24	522220
BT30	3/8	2.36	1.26	1.00	3/8-24	522222
BT30	1/2	2.36	1.50	1.38	7/16-20	522224
BT30	3/4	3.00	1.77	1.88	5/8-18	522228

End Mill Holders & Shell Mill Holders

BT40 End Mill Holders



- DIN coolant option - standard
- All ground body, bore, nose, flange
- TIR, 0.0001" / 0.003mm OD to ID
- AT2 Taper Accuracy
- Certified Steel
- RFID chip hole

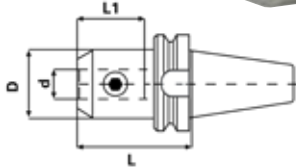

PREMIUM BALANCE
G6.3 at 30,000rpm
CERTIFICATE INCLUDED

Taper	Hole Dia. (d)	Gauge Length (L)	L1	D	Set Screw	Code No.
BT40	1/8	1.38*	0.59	1.75	8-32	531019
BT40	1/8	2.50	0.59	0.75	8-32	531021
BT40	1/8	4.00	0.59	0.75	8-32	531023
BT40	3/16	1.38*	0.79	0.75	10-32	531025
BT40	3/16	2.50	0.79	0.75	10-32	531027
BT40	3/16	4.00	0.79	0.75	10-32	531029
BT40	1/4	1.38*	1.18	0.79	1/4-28	532018
BT40	1/4	2.50	1.18	0.79	1/4-28	532020
BT40	1/4	4.00	1.18	0.79	1/4-28	532022
BT40	5/16	1.38*	1.18	0.87	5/16-24	532024
BT40	5/16	2.50	1.18	0.87	5/16-24	532026
BT40	5/16	4.00	1.18	0.87	5/16-24	532028
BT40	3/8	1.38*	1.57	1.00	3/8-24	532030
BT40	3/8	2.50	1.57	1.00	3/8-24	532032
BT40	3/8	4.00	1.57	1.00	3/8-24	532034
BT40	7/16	2.50	1.50	1.38	7/16-20	532036
BT40	1/2	1.75*	1.50	1.38	7/16-20	532038
BT40	1/2	2.50	2.56	1.38	7/16-20	532040
BT40	1/2	4.00	2.56	1.38	7/16-20	532042
BT40	5/8	1.75*	1.97	1.65	9/16-18	532044
BT40	5/8	2.50	2.76	1.65	9/16-18	532046
BT40	5/8	4.00	3.50	1.65	9/16-18	532048
BT40	3/4	1.75*	2.01	1.89	5/8-18	532050
BT40	3/4	2.50	2.56	1.89	5/8-18	532052
BT40	3/4	4.00	2.56	1.89	5/8-18	532054
BT40	7/8	3.38	4.06	2.00	5/8-18	532056
BT40	7/8	6.00	2.08	2.00	5/8-18	532058
BT40	1	2.00*	2.32	2.25	3/4-16	532060
BT40	1	3.56	3.54	2.36	3/4-16	532062
BT40	1	6.00	3.54	2.36	3/4-16	532064
BT40	1-1/4	2.00*	2.36	2.25	3/4-16	532066†
BT40	1-1/4	3.56	3.54	2.48	3/4-16	532068
BT40	1-1/4	6.00	3.54	2.48	3/4-16	532070
BT40	1-1/2	4.50	3.15	2.99	3/4-16	532072
BT40	1-1/2	6.00	3.15	2.99	3/4-16	532074

* Stubby Length

† Not DIN Coolant

BT40 DIRECT COOLANT End Mill Holders



NOW 3 COOLANT OPTIONS ALL IN ONE!

- Coolant through the spindle
- DIN coolant through flange option
- Coolant through the body
- All ground body, bore, nose, flange
- TIR, 0.0001" / 0.003mm OD to ID
- AT2 Taper Accuracy
- Certified Steel
- RFID chip hole

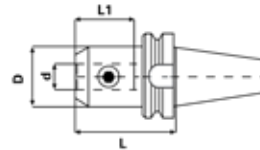

PREMIUM BALANCE
G6.3 at 30,000rpm
CERTIFICATE INCLUDED

Taper	Hole Dia. (d)	Gauge Length (L)	L1	D	Set Screw	Code No.
BT40	1/4	4.00	1.10	0.79	1/4-28	522246
BT40	3/8	2.50	1.57	1.00	3/8-24	522256
BT40	3/8	4.00	1.57	1.00	3/8-24	522258
BT40	1/2	2.50	2.56	1.38	7/16-20	522264
BT40	1/2	4.00	2.56	1.38	7/16-20	522266
BT40	3/4	2.50	2.56	1.89	5/8-18	522276
BT40	3/4	4.00	2.56	1.89	5/8-18	522278
BT40	1	2.00*	2.32	2.25	3/4-16	522282

BT50 End Mill Holders



- DIN coolant option - standard
- All ground body, bore, nose, flange
- TIR, 0.0001" / 0.003mm OD to ID
- AT2 Taper Accuracy
- Certified Steel
- RFID chip hole

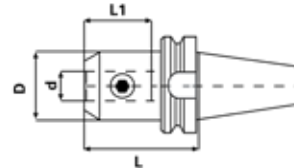

PREMIUM BALANCE
G6.3 at 25,000rpm
CERTIFICATE INCLUDED

Taper	Hole Dia. (d)	Gauge Length (L)	L1	D	Set Screw	Code No.
BT50	3/8	2.50	1.57	1.00	3/8-24	532075
BT50	3/8	5.31	1.57	1.00	3/8-24	532076
BT50	1/2	2.75	1.77	1.38	7/16-20	532077
BT50	1/2	5.31	1.77	1.38	7/16-20	532078
BT50	5/8	3.00	1.77	1.65	9/16-18	532079
BT50	5/8	5.31	1.77	1.65	9/16-18	532081
BT50	3/4	3.00	2.76	1.75	5/8-18	532083
BT50	3/4	6.00	3.82	1.75	5/8-18	532085
BT50	1	4.00	4.21	2.36	3/4-16	532087
BT50	1	6.00	3.54	2.36	3/4-16	532089
BT50	1-1/4	4.00	3.54	2.48	3/4-16	532091
BT50	1-1/4	6.00	3.54	2.48	3/4-16	532093
BT50	1-1/2	4.13	3.15	2.99	3/4-16	532095
BT50	1-1/2	7.00	3.15	2.99	3/4-16	532097
BT50	2	4.72	4.13	3.86	1-14	532099

HSK63A End Mill Holders



- High rigidity and torque transmission
- All ground body, bore, nose, flange
- TIR, 0.0001" / 0.003mm OD to ID
- Certified Steel
- AT2 Taper Accuracy
- RFID chip hole

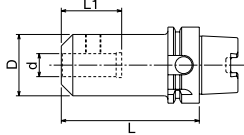

PREMIUM BALANCE
G6.3 at 30,000rpm
CERTIFICATE INCLUDED

Taper	Hole Dia. (d)	Gauge Length (L)	L1	D	Set Screw	Code No.
HSK63A	3/16	3.00	0.866	0.748	10-32X1/4	536002
HSK63A	3/16	5.00	0.866	0.748	10-32X1/4	536004
HSK63A	1/4	3.00	1.102	0.787	1/4-28X1/4	536006
HSK63A	1/4	5.00	1.102	0.787	1/4-28X1/4	536008
HSK63A	5/16	3.00	1.417	0.874	5/16-24X1/4	536010
HSK63A	5/16	5.00	1.417	0.874	5/16-24X1/4	536012
HSK63A	3/8	3.50	1.574	1.00	3/8-24X5/16	536014
HSK63A	3/8	5.00	1.574	1.00	3/8-24X5/16	536016
HSK63A	7/16	5.00	1.771	1.378	7/16-20X3/8	536020
HSK63A	1/2	4.00	1.771	1.378	7/16-20X3/8	536022
HSK63A	1/2	5.00	1.771	1.378	7/16-20X3/8	536024
HSK63A	5/8	4.00	1.889	1.654	9/16-18X1/2	536026
HSK63A	3/4	4.50	1.968	1.889	5/8-18X1/2	536030
HSK63A	3/4	6.00	1.968	1.889	5/8-18X1/2	536032
HSK63A	1	4.50	2.755	2.363	3/4-16X11/16 (2)	536034
HSK63A	1-1/4	4.50	2.952	2.88	3/4-16X11/16 (2)	536038

HSK100A End Mill Holders



- High rigidity and torque transmission
- All ground body, bore, nose, flange
- TIR, 0.0001" / 0.003mm OD to ID
- Certified Steel
- AT2 Taper Accuracy
- RFID chip hole

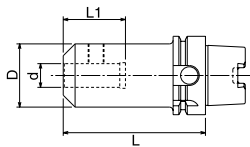

PREMIUM BALANCE
G6.3 at 25,000rpm
CERTIFICATE INCLUDED

Taper	Hole Dia. (d)	Gauge Length (L)	L1	D	Set Screw	Code No.
HSK100A	3/16	4.00	0.867	0.748	10-32X1/4	536042
HSK100A	3/16	6.00	0.867	0.748	10-32X1/4	536044
HSK100A	1/4	4.00	1.102	0.787	1/4-28X1/4	536046
HSK100A	1/4	6.00	1.102	0.787	1/4-28X1/4	536048
HSK100A	5/16	4.00	1.220	0.866	5/16-24X1/4	536050
HSK100A	5/16	6.00	1.220	0.866	5/16-24X1/4	536052
HSK100A	3/8	4.00	1.260	1.00	3/8-24X5/16	536054
HSK100A	3/8	6.00	1.260	1.00	3/8-24X5/16	536056
HSK100A	1/2	4.00	1.575	1.378	7/16-20X3/8	536062
HSK100A	1/2	6.00	1.575	1.378	7/16-20X3/8	536064
HSK100A	5/8	4.00	1.693	1.654	9/16-18X1/2	536066
HSK100A	3/4	4.00	2.56	1.890	5/8-18X1/2	536070
HSK100A	3/4	6.00	1.969	1.890	5/8-18X1/2	536072
HSK100A	1	4.00	2.559	2.362	3/4-16X11/16 (2)	536074
HSK100A	1	6.00	2.559	2.362	3/4-16X11/16 (2)	536076
HSK100A	1-1/4	4.00	2.559	2.480	3/4-16X11/16 (2)	536078
HSK100A	1-1/4	6.00	2.559	2.480	3/4-16X11/16 (2)	536080

NMTB40 End Mill Holders



- All ground body, bore, nose, flange
- TIR, 0.0001" / 0.003mm OD to ID
- Certified Steel

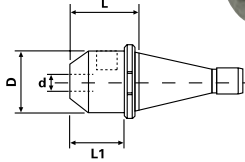

Taper	Hole Dia. (d)	Gauge Length (L)	L1	D	Set Screw	Code No.
NMTB40	1/4	2.31	1.97	0.79	1/4-28	534000
NMTB40	5/16	2.31	1.18	0.87	5/16-24	534002
NMTB40	3/8	2.31	1.57	1.00	3/8-24	534004
NMTB40	1/2	2.31	2.56	1.38	7/16-20	534008
NMTB40	5/8	2.31	2.76	1.65	9/16-18	534010
NMTB40	3/4	2.31	2.76	1.89	5/8-18	534012
NMTB40	7/8	2.94	3.15	2.01	5/8-18	534014
NMTB40	1	3.37	3.54	2.36	3/4-16	534016
NMTB40	1-1/4	3.69	3.54	2.48	3/4-16	534018
NMTB40	1-1/2	3.95	2.95	2.99	3/4-16	534019

NMTB50 End Mill Holders



- All ground body, bore, nose, flange
- TIR, 0.0001" / 0.003mm OD to ID
- Certified Steel

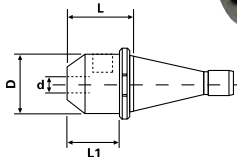

Taper	Hole Dia. (d)	Gauge Length (L)	L1	D	Set Screw	Code No.
NMTB50	1/4	2.75	1.57	0.79	1/4-28	534020
NMTB50	3/8	2.75	1.57	1.00	3/8-24	534022
NMTB50	1/2	2.75	1.50	1.38	7/16-20	534026
NMTB50	1/2	4.50	1.50	1.38	7/16-20	534028
NMTB50	5/8	2.75	1.77	1.65	9/16-18	534030
NMTB50	3/4	2.88	1.77	1.89	5/8-18	534034
NMTB50	3/4	4.50	2.76	1.89	5/8-18	534036
NMTB50	7/8	2.88	2.17	2.01	5/8-18	534038
NMTB50	1	3.50	2.36	2.36	3/4-16	534042
NMTB50	1-1/4	3.50	2.56	2.48	3/4-16	534046
NMTB50	2	4.69	4.13	3.74	1-14	534054

End Mill Holders & Shell Mill Holders

R8 End Mill Holders



- All ground body, bore, nose, flange
- TIR, 0.0001" / 0.003mm OD to ID
- Certified Steel

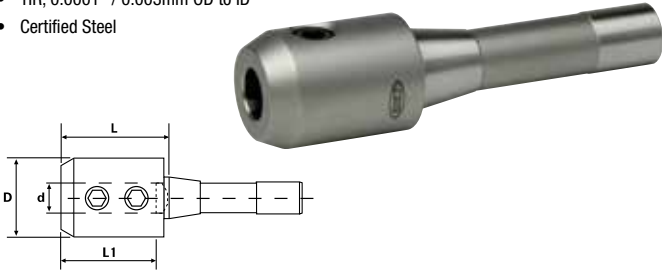

Taper	Hole Dia. (d)	Gauge Length (L)	L1	D	Set Screw	Code No.
R8	1/4	1.33	1.18	0.79	1/4-28	534056
R8	5/16	1.75	1.26	0.87	5/16-24	534058
R8	3/8	1.33	1.26	1.00	3/8-24	534060
R8	1/2	1.33	2.56	1.38	7/16-20	534064
R8	5/8	1.50	1.61	1.65	9/16-18	534066
R8	3/4	2.37	1.77	1.89	5/8-18	534068
R8	1	3.25	2.76	2.36	3/4-16	534072
R8	1-1/4	3.25	3.15	2.48	3/4-16	534074

Straight Shank End Mill Holders



- Can be used to extend the reach of the cutting tool as well as machining within tight clearances
- All ground body, bore, nose, flange
- TIR, 0.0001" / 0.003mm OD to ID
- Certified Steel

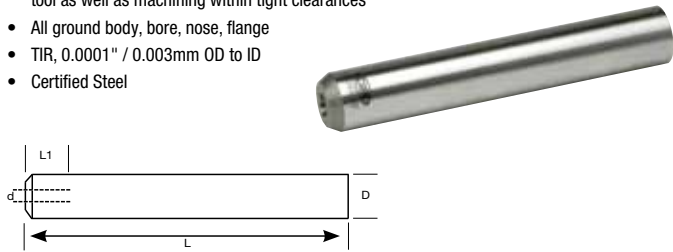

Hole Dia. (d)	Gauge Length (L)	L1	D	Set Screw	Code No.
1/4	6.00	1.18	0.750	1/4-28	534078
5/16	6.00	1.18	0.750	5/16-24	534080
3/8	6.00	1.57	1.00	3/8-24	534082
1/2	6.00	1.77	1.00	1/4-28	534084

Blank Bars



Blank bars are suitable for all applications, including deep boring. While the tapers are ground and hardened, the projections are not.

- Traverse ground shank to obtain optimum accuracy
- Meets or exceeds ANSI specifications
- Material to be machined - SNM 415H

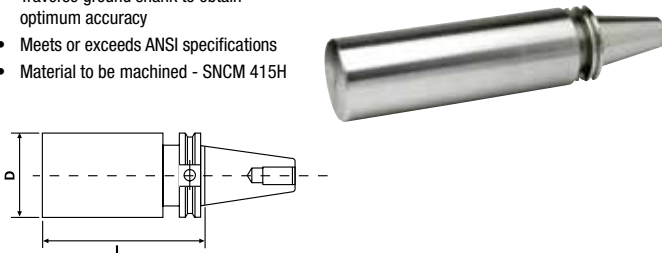

Taper	L	D	Code No.
CAT Taper			
CAT 40	13	2.50	531592
CAT 50	13	3.88	531594
NMTB Taper			
NMTB50	13	3.88	534602

HSK Coolant Tubes



- Designed specifically to be used with HSK holders
- Leak-proof screwed connection

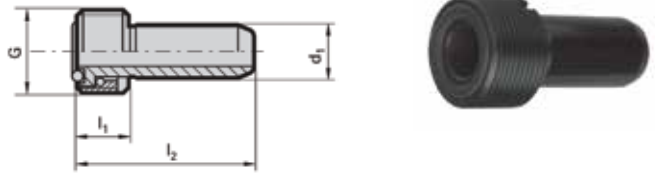

Used with Taper	d1	G	l1	l2	Code No.
HSK63A	12	M18x1	36.5	11.5	536600
HSK100A	16	M24x1.5	44.0	15.5	536602

Coolant Tube Wrenches



- Designed to lock and unlock the HSK coolant supply units



Description	Used with Taper	Code No.
Coolant Tube Wrench	HSK63A	536604
Coolant Tube Wrench	HSK100A	536606

Replacement O-Rings For DIRECT COOLANT Holders



- Can be used in all tapers of Direct Coolant Holders



Holder Size	Code No.
1/4	522390
5/16	522391
3/8	522392
1/2	522393
5/8	522394
3/4	522395
1	522396
1-1/4	522397

Replacement Set Screws



Size	Size of Holder	Code No.
8-32 x 5/16	1/8	534109
10-32 x 5/16	3/16	534111
1/4-28 x 1/4	1/4	534110
5/16-24 x 1/4	5/16	534112
3/8-24 x 5/16	3/8, 7/16	534114
7/16-20 x 3/8	1/2	534116
9/16-18 x 1/2	5/8	534118
5/8-18 x 1/2	3/4, 7/8	534120
3/4-16 x 9.5mm	1, 1-1/4, 1-1/2	534119
3/4-16 x 11/16	1, 1-1/4, 1-1/2	534122
1-14 x 7/8	2	534124

Retention Knobs

- Ground Pilot
- O-Ring on Pilot to prevent coolant penetration into the spindle

Can't find your retention knob?

We invite your inquiries.

Please have ready the following information when calling:

- Taper of Machine
- Make and Model No. of the Machine
- Draw Bar Thread Diameter and Pitch
- Taper Angle required underneath head of stud

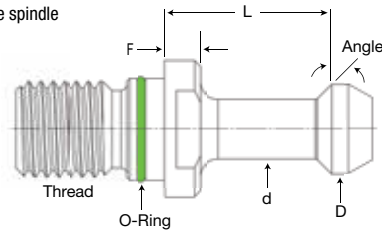

Taper	Model	Coolant Through	D	d	L	F	Angle	Thread	Code No.
BT30	GS585X45	N	0.433	0.276	0.709	0.197	45	M12x1.75	366000
BT30	GS585X60	N	0.433	0.276	0.709	0.197	60	M12x1.75	366002
BT40	PS444X15	N	0.748	0.551	0.905	0.275	15	M16x2	366003
BT40	GSC444X15	Y	0.748	0.551	0.905	0.275	15	M16x2	366004
BT40	GS444X45	N	0.590	0.390	1.102	0.236	45	M16x2	366006
BT40	GS444X60	N	0.590	0.390	1.102	0.236	60	M16x2	366008
BT40	PS444X90	N	0.590	0.390	1.102	0.236	90	M16x2	366010
BT40	GSC444X45	Y	0.590	0.390	1.102	0.236	45	M16x2	366012
BT40	GSC444X60	Y	0.590	0.390	1.102	0.236	60	M16x2	366014
BT40	PSC444X90	Y	0.590	0.390	1.102	0.236	90	M16x2	366016
BT40	PS477	N	0.740	0.490	0.552	0.236	45	M16x2	366018
BT40	PSC478	Y	0.740	0.490	0.440	0.120	45	M16x2	366020
BT40	PSC479	Y	0.740	0.490	0.552	0.120	45	M16x2	366022
BT40	GSC477	Y	0.740	0.490	0.552	0.236	45	M16x2	366024
BT40	PSC480X15	Y	0.748	0.551	0.900	0.157	15	M16x2	366026
BT40	PS534X45	N	0.590	0.390	0.990	0.236	45	M16x2	366028
BT40	PS554	N	0.594	0.406	1.250	0.187	45	M16x2	366030
BT40	PSC554	Y	0.594	0.406	1.250	0.187	45	M16x2	366032
CT40	GSC470X15	Y	0.748	0.551	0.787	0.157	15	5/8x11	366034
CT40	GS474	N	0.740	0.490	0.440	0.118	45	5/8x11	366036
CT40	GSC474	Y	0.740	0.490	0.440	0.118	45	5/8x11	366038
CT40	GSC475	Y	0.740	0.490	0.440	0.120	45	5/8x11	366040
CT40	GS475	N	0.740	0.490	0.440	0.120	45	5/8x11	366042
CT40	PS498	N	0.590	0.390	0.777	0.200	90	5/8x11	366044
CT40	PS531X45	N	0.590	0.390	1.000	0.236	45	5/8x11	366046
CT40	GS532X15	N	0.748	0.551	0.792	0.275	15	5/8x11	366048
CT40	GS532X45	N	0.590	0.390	0.990	0.236	45	5/8x11	366050
CT40	GS532X60	N	0.590	0.390	0.990	0.236	60	5/8x11	366052
CT40	GS532X90	N	0.590	0.390	0.990	0.236	90	5/8x11	366054
CT40	GSC532X15	Y	0.748	0.551	0.792	0.275	15	5/8x11	366056
CT40	GSC532X45	Y	0.590	0.390	0.990	0.236	45	5/8x11	366058
CT40	GSC532X60	Y	0.590	0.390	0.990	0.236	60	5/8x11	366060
CT40	GSC532X90	Y	0.590	0.390	0.990	0.236	90	5/8x11	366062
CT40	PS552	N	0.594	0.406	1.139	0.187	45	5/8x11	366064
CT40	PSC552	Y	0.594	0.406	1.139	0.187	45	5/8x11	366066
CT40	GS572X45	N	0.590	0.390	0.990	0.120	45	5/8x11	366068
CT40	PS572X60	N	0.590	0.390	0.990	0.120	60	5/8x11	366070
CT40	PS572X90	N	0.590	0.390	0.990	0.120	90	5/8x11	366072
CT40	PSC572X45	Y	0.590	0.390	0.990	0.120	45	5/8x11	366074
CT40	PSC572X60	Y	0.590	0.390	0.990	0.120	60	5/8x11	366076
CT40	PSC572X90	Y	0.590	0.390	0.990	0.120	90	5/8x11	366078
CT45	PSC375	Y	0.940	0.605	0.580	0.160	45	3/4x10	366080
BT50	PSC278	Y	1.140	0.820	0.700	0.200	45	M24x3	366082
BT50	GS446X45	N	0.906	0.669	1.378	0.394	45	M24x3	366084
BT50	PS446X60	N	0.906	0.669	1.378	0.394	60	M24x3	366086
BT50	PS446X90	N	0.906	0.669	1.378	0.394	90	M24x3	366088
BT50	GSC446X45	Y	0.906	0.669	1.378	0.394	45	M24x3	366090
CT50	GS275	N	1.140	0.820	0.700	0.200	45	1x8	366092
CT50	PSC274	Y	1.140	0.820	0.700	0.200	45	1x8	366094
CT50	GSC275	Y	1.140	0.820	0.700	0.200	45	1x8	366096
CT50	GS536X45	N	0.906	0.669	1.386	0.394	45	1x8	366098
CT50	GS536X60	N	0.906	0.669	1.386	0.394	60	1x8	366100
CT50	GS536X90	N	0.906	0.669	1.386	0.394	90	1x8	366102
CT50	GSC536X45	Y	0.906	0.669	1.386	0.394	45	1x8	366104
CT50	GSC536X60	Y	0.906	0.669	1.386	0.394	60	1x8	366106
CT50	GSC536X90	Y	0.906	0.669	1.386	0.394	90	1x8	366108

End Mill Holders & Shell Mill Holders

CAT40 Shell Mill Holders



- DIN coolant option - standard
- All ground body, nose, pilot, flange
- TIR, 0.0001" / 0.003mm OD to ID
- AT2 Taper Accuracy
- Certified Steel
- RFID chip hole

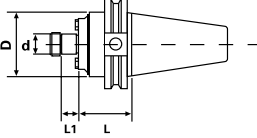

Taper	d	L	D	L1	Key Size	Arbor Thread	Code No.
CT40	1/2	1.75	1.38	0.57	1/4	1/4-28	531190
CT40	3/4	1.75	1.75	0.67	5/16	3/8-24	531192
CT40	3/4	4.00	1.75	0.67	5/16	3/8-24	531194
CT40	3/4	6.00	1.75	0.67	5/16	3/8-24	531195
CT40	1	1.75	2.38	0.67	3/8	1/2-20	531196
CT40	1	4.00	2.38	0.67	3/8	1/2-20	531198
CT40	1	6.00	2.38	0.67	3/8	1/2-20	531199
CT40	1-1/4	2.00	2.88	0.67	1/2	5/8-18	531200
CT40	1-1/4	4.00	2.88	0.67	1/2	5/8-18	531202
CT40	1-1/4	6.00	2.88	0.67	1/2	5/8-18	531203
CT40	1-1/2	2.00	3.80	0.93	5/8	3/4-16	531204
CT40	1-1/2	4.00	3.80	0.93	5/8	3/4-16	531206

CAT50 Shell Mill Holders



- DIN coolant option - Standard
- All ground body, nose, pilot, flange
- TIR, 0.0001" / 0.003mm OD to ID
- AT2 Taper Accuracy
- Certified Steel
- RFID chip hole

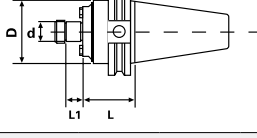

Taper	d	L	D	L1	Key Size	Arbor Thread	Code No.
CT50	3/4	1.75	2.00	0.67	5/16	3/8-24	531208
CT50	3/4	4.00	2.00	0.67	5/16	3/8-24	531210
CT50	3/4	6.00	2.00	0.67	5/16	3/8-24	531212
CT50	3/4	8.00	2.00	0.67	5/16	3/8-24	531214
CT50	1	1.75	2.75	0.69	3/8	1/2-20	531216
CT50	1	4.00	2.75	0.69	3/8	1/2-20	531218
CT50	1	6.00	2.75	0.69	3/8	1/2-20	531220
CT50	1	8.00	2.75	0.69	3/8	1/2-20	531222
CT50	1-1/4	1.75	2.88	0.69	1/2	5/8-18	531224
CT50	1-1/4	4.00	2.88	0.69	1/2	5/8-18	531226
CT50	1-1/4	6.00	2.88	0.69	1/2	5/8-18	531228
CT50	1-1/4	8.00	2.88	0.69	1/2	5/8-18	531230
CT50	1-1/2	2.00	3.80	0.93	5/8	3/4-16	531232
CT50	1-1/2	4.00	3.80	0.93	5/8	3/4-16	531234
CT50	1-1/2	6.00	3.80	0.93	5/8	3/4-16	531236
CT50	1-1/2	8.00	3.80	0.93	5/8	3/4-16	531238
CT50	2	2.00	4.38	0.93	3/4	1-14	531240
CT50	2	4.00	4.38	0.93	3/4	1-14	531242
CT50	2	6.00	4.38	0.93	3/4	1-14	531244

CAT40 DUAL CONTACT Shell Mill Holders



- DIN coolant through the flange option - Standard
- Improves rigidity and reduces vibration allowing for increased feed rates and increased tool life
- All ground body, nose, pilot, flange
- TIR, 0.0001" / 0.003mm OD to ID
- AT2 Taper Accuracy
- Certified Steel
- RFID chip hole

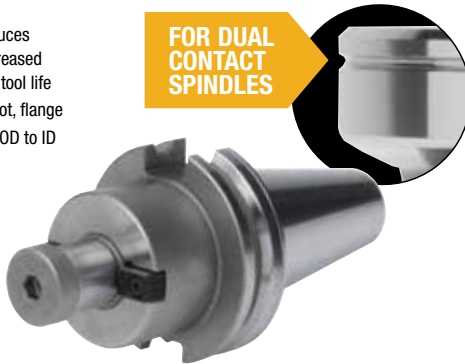

FOR DUAL CONTACT SPINDLES

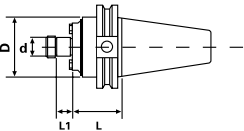

Taper	d	L	D	L1	Key Size	Arbor Thread	Code No.
CT40	3/4	1.75	1.75	0.67	5/16	3/8-24	521192
CT40	3/4	4.00	1.75	0.67	5/16	3/8-24	521194
CT40	3/4	6.00	1.75	0.67	5/16	3/8-24	521195
CT40	1	1.75	2.38	0.67	3/8	1/2-20	521196
CT40	1	4.00	2.38	0.67	3/8	1/2-20	521198
CT40	1	6.00	2.38	0.67	3/8	1/2-20	521199
CT40	1-1/4	2.00	2.88	0.67	1/2	5/8-18	521200
CT40	1-1/4	4.00	2.88	0.67	1/2	5/8-18	521202
CT40	1-1/2	2.00	3.80	0.93	5/8	3/4-16	521204
CT40	1-1/2	4.00	3.80	0.93	5/8	3/4-16	521206

CAT50 DUAL CONTACT Shell Mill Holders



- DIN Coolant through the flange option - Standard
- Improves rigidity and reduces vibration allowing for increased feed rates and increased tool life
- All ground body, nose, pilot, flange
- TIR, 0.0001" / 0.003mm OD to ID
- AT2 Taper Accuracy
- Certified Steel
- RFID chip hole



FOR DUAL CONTACT SPINDLES

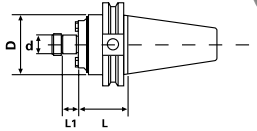

Taper	d	L	D	L1	Key Size	Arbor Thread	Code No.
CT50	3/4	1.75	2.00	0.67	5/16	3/8-24	521208
CT50	3/4	4.00	2.00	0.67	5/16	3/8-24	521210
CT50	3/4	6.00	2.00	0.67	5/16	3/8-24	521212
CT50	1	1.75	2.75	0.69	3/8	1/2-20	521216
CT50	1	4.00	2.75	0.69	3/8	1/2-20	521218
CT50	1	6.00	2.75	0.69	3/8	1/2-20	521220
CT50	1	8.00	2.75	0.69	3/8	1/2-20	521222
CT50	1-1/4	1.75	2.88	0.69	1/2	5/8-18	521224
CT50	1-1/4	4.00	2.88	0.69	1/2	5/8-18	521226
CT50	1-1/4	6.00	2.88	0.69	1/2	5/8-18	521228
CT50	1-1/4	8.00	2.88	0.69	1/2	5/8-18	521230
CT50	1-1/2	2.00	3.80	0.93	5/8	3/4-16	521232
CT50	1-1/2	4.00	3.80	0.93	5/8	3/4-16	521234
CT50	1-1/2	6.00	3.80	0.93	5/8	3/4-16	521236
CT50	1-1/2	8.00	3.80	0.93	5/8	3/4-16	521238
CT50	2	2.00	4.38	0.93	3/4	1-14	521240
CT50	2	4.00	4.38	0.93	3/4	1-14	521242

CAT50 Face Mill Holders



- All ground body
- 4 bolts, 5/8-11
- 4" bolt circle
- AT2 Taper Accuracy
- RFID chip hole

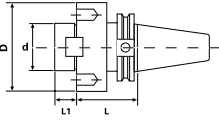

Taper	d	L	D	L1	Key Size	Code No.
CT50	2	2.95	5.06	0.86	3/4	531246
CT50	2-1/2	2.95	5.00	1.18	1	531248

HSK63A Shell Mill Holders



- High rigidity and torque transmission
- All ground body, nose, pilot, flange
- TIR, 0.0001" / 0.003mm OD to ID
- Certified Steel
- AT2 Taper Accuracy
- RFID chip hole

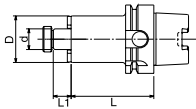

Taper	d	L	D	L1	Key Size	Arbor Thread	Code No.
HSK63A	3/4	3.00	1.693	0.669	5/16	3/8-24	536082
HSK63A	3/4	5.00	1.693	0.669	5/16	3/8-24	536084
HSK63A	1	3.00	2.165	0.669	3/8	1/2-20	536086
HSK63A	1	5.00	2.165	0.669	3/8	1/2-20	536088
HSK63A	1-1/4	3.00	2.756	0.669	1/2	5/8-18	536090
HSK63A	1-1/4	5.00	2.756	0.669	1/2	5/8-18	536092

BT Taper Shell Mill Holders



- DIN coolant option - standard
- All ground body, nose, pilot, flange
- TIR, 0.0001" / 0.003mm OD to ID
- AT2 Taper Accuracy
- Certified Steel
- RFID chip hole

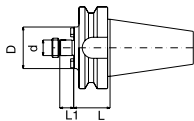

Taper	d	L	D	L1	Key Size	Arbor Thread	Code No.
BT30							
BT30	1/2	1.19	1.38	0.57	1/4	1/4-28	532080†
BT30	3/4	1.19	2.00	0.67	5/16	3/8-24	532082†
BT30	1	1.77	2.38	0.69	3/8	1/2-20	532084†
BT40							
BT40	1/2	1.75	1.38	0.57	1/4	1/4-28	532086
BT40	3/4	1.75	1.75	0.67	5/16	3/8-24	532088
BT40	3/4	4.00	1.75	0.67	5/16	3/8-24	532111
BT40	3/4	6.00	1.75	0.67	5/16	3/8-24	532114
BT40	1	1.75	2.38	0.67	3/8	1/2-20	532090
BT40	1	4.00	2.38	0.67	3/8	1/2-20	532115
BT40	1	6.00	2.38	0.67	3/8	1/2-20	532117
BT40	1-1/4	2.00	2.88	0.67	1/2	5/8-18	532092
BT40	1-1/4	4.00	2.88	0.67	1/2	5/8-18	532119
BT40	1-1/4	6.00	2.88	0.67	1/2	5/8-18	532121
BT40	1-1/2	2.00	3.80	0.92	5/8	3/4-16	532094
BT50							
BT50	1	1.75	2.75	0.69	3/8	1/2-20	532101
BT50	1-1/4	1.75	2.88	0.69	1/2	5/8-18	532103
BT50	1-1/2	1.75	3.80	0.92	5/8	3/4-16	532105
BT50	2	1.75	4.38	0.92	3/4	1-14	532107

† Not DIN Coolant

HSK100A Shell Mill Holders



- High rigidity and torque transmission
- All ground body, nose, pilot, flange
- TIR, 0.0001" / 0.003mm OD to ID
- Certified Steel
- AT2 Taper Accuracy
- RFID chip hole

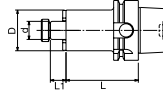

Taper	d	L	D	L1	Key Size	Arbor Thread	Code No.
HSK100A	3/4	4.00	1.693	0.669	5/16	3/8-24	536094
HSK100A	3/4	6.00	1.693	0.669	5/16	3/8-24	536096
HSK100A	1	4.00	2.165	0.669	3/8	1/2-20	536098
HSK100A	1	6.00	2.165	0.669	3/8	1/2-20	536100
HSK100A	1-1/2	4.00	3.504	0.902	5/8	3/4-16	536106
HSK100A	1-1/2	6.00	3.504	0.902	5/8	3/4-16	536108

NMTB Taper Shell Mill Holders



- All ground body, nose, pilot, flange
- TIR, 0.0001" / 0.003mm OD to ID
- Certified Steel

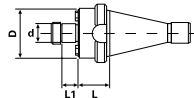

Taper	d	L	D	L1	Key Size	Arbor Thread	Code No.
NMTB40							
NMTB40	1/2	0.87	1.38	0.57	1/4	1/4-28	534130
NMTB40	3/4	0.87	1.94	0.67	5/16	3/8-24	534132
NMTB40	1	1.31	2.38	0.67	3/8	1/2-20	534134
NMTB40	1-1/4	1.50	2.88	0.67	1/2	5/8-18	534136
NMTB40	1-1/2	1.63	3.50	0.93	5/8	3/4-16	534138
NMTB50							
NMTB50	3/4	1.25	2.00	0.67	5/16	3/8-24	534140
NMTB50	1	1.88	2.38	0.67	3/8	1/2-20	534142
NMTB50	1-1/4	1.88	2.88	0.67	1/2	5/8-18	534144
NMTB50	1-1/2	1.88	3.50	0.93	5/8	3/4-16	534146
NMTB50	2	1.88	4.38	0.93	3/4	1-14	534148

NMTB50 Taper Face Mill Holders



- All ground body
- 4 bolts, 5/8-11
- 4" bolt circle

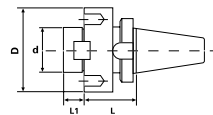

Taper	d	L	D	L1	Key Size	Code No.
NMTB50	2-1/2	3.00	5.00	1.18	1	534152

R8 Shell Mill Holders



- All ground body, nose, pilot, flange
- TIR, 0.0001" / 0.003mm OD to ID
- Certified Steel

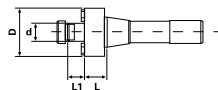

Taper	d	L	D	L1	Key Size	Arbor Thread	Code No.
R8	1/2	1.00	1.38	0.57	1/4	1/4-28	534154
R8	3/4	1.00	2.00	0.69	5/16	3/8-24	534156
R8	1	1.00	2.38	0.69	3/8	1/2-20	534158
R8	1-1/4	1.00	2.88	0.69	1/2	5/8-18	534160
R8	1-1/2	1.75	3.50	0.94	5/8	3/4-16	534162

End Mill Holders & Shell Mill Holders

Replacement Drive Keys



Spigot Dia.	Description	Code No.
1/2	Two 1/4 Drive keys	534164
3/4	Two 5/16	534166
1	Two 3/8	534168
1-1/4	Two 1/2	534170
1-1/2	Two 5/8	534172
2	Two 3/4	534174
2-1/2	Two 1	534176

Replacement Arbor Screws



Thread Size	Size of Holder	Code No.
5/8-11	Face Mill Mounting Bolt	534178
1/4-28	1/2	534180
3/8-24	3/4	534182
1/2-20	1	534184
5/8-18	1-1/4	534186
3/4-16	1-1/2	534188
1-14	2	534190



From simple to deluxe, we have a Tool Setting Stand to suit your needs.

See www.SowaTool.com

CAT Taper Stub Arbors



- Each arbor equipped with 1/8, 1/4, 3/8, 1/2 spacers

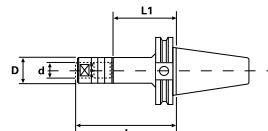

Taper	d	L	D	L1	Code No.
CAT40					
CT40	1	6.17	1.50	4.00	531580
CT40	1-1/4	6.29	1.75	4.00	531582
CT40	1-1/2	6.60	2.12	4.00	531584
CAT50					
CT50	1	6.17	1.50	4.00	531586
CT50	1-1/4	6.28	1.75	4.00	531588
CT50	1-1/2	6.60	2.12	4.00	531590

Replacement Stub Arbor Spacers



Description	Code No.
1/8" Spacer for 3/4" Holder	534568
1/4" Spacer for 3/4" Holder	534570
3/8" Spacer for 3/4" Holder	534572
1/2" Spacer for 3/4" Holder	534574
1/8" Spacer for 1" Holder	534576
3/8" Spacer for 1" Holder	534580
1/8" Spacer for 1-1/4" Holder	534584
3/8" Spacer for 1-1/4" Holder	534588
1/8" Spacer for 1-1/2" Holder	534592
3/8" Spacer for 1-1/2" Holder	534596
1/2" Spacer for 1-1/2" Holder	534598



Grab a Tool Trolley with 4 Tool Trays and Inserts for all your Holders.

See www.SowaTool.com



Superior performance tool holding and workholding solutions when speed and accuracy matter most.

GS Tooling is an industry leader in precision tooling where high-performance and stringent quality standards are paramount. Tool your World with GS Tooling End Mill Holders, Collet Chucks & Collets, Retention Knobs, Vises & Workholding, Live Centers, Angle Heads, Carbide End Mills and more!



Tool Holding



Angle Heads & Driven Tooling



Cutting Tools



Vises & Workholding



Welcome to the **Sowa** family!



Superior performance tool holding and workholding solutions when speed and accuracy matter most.

ASIMETO

High-performance precision measuring and inspecting solutions.



High-performance cutting tools including end mills, drills, taps and indexables.

SKODA

High Value production grade live centers.

narex

Exclusive line of value boring heads.



A wide product range of economic tooling for general purpose applications.



With this line-up, Sowa Tool is uniquely qualified to serve all your needs under one roof. Ask us how Sowa can tool your world and provide the competitive edge for your business.

Distributed by:



COMPLETE METALWORKING SOLUTIONS

(800) 991-4225

www.ahbinc.com

ISO Certified

customerservice@ahbinc.com

Sowa
TOOLING YOUR WORLD.

Sowa Tool & Machine Co. Ltd.

Canadian Head Office
500 Manitou Drive, Kitchener, ON, N2C 1L3

North Carolina Office
101-137 Overhill Drive, Mooresville, NC 28117