

SOWA

TOOLING
YOUR
WORLD.

AHB

TOOLING & MACHINERY

COMPLETE METALWORKING SOLUTIONS

(800) 991-4225

www.ahbinc.com

ISO Certified

customerservice@ahbinc.com

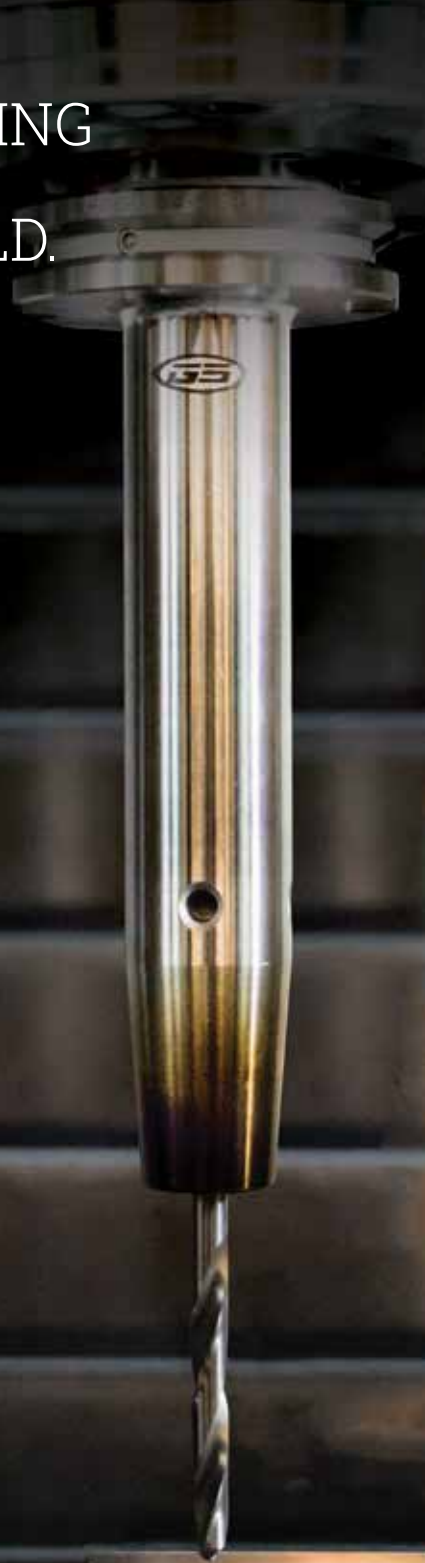

Shrink Fit Holders



Shrink Fit Holder Features	3
CAT40 & 50 Shrink Fit Holders	4
BT30 & 40 Shrink Fit Holders	5
HSK65A & 100A Shrink Fit Holders	6

Sowa Tool has been serving the metalworking industry since 1960.

Your world is full of challenges and worrying about having the right tools for the job should not be one of them. With a three-generation legacy of family-style customer service, Sowa Tool & Machine has been trusted by manufacturers and distributors throughout North America to supply some of the industry's best metalworking solutions since 1960.

Our mission has been and continues to be to provide the broadest range of metalworking solutions in the industry. We accomplish this through the continuous development of our family of brands that include items within the Tool Holding, Workholding, Measuring & Inspecting, and Cutting Tool categories. This allows you to secure all these solutions from one place, reducing your total number of purchase orders and consolidating your freight charges in this increasingly expensive market.

Our wide array of metalworking products come in stock with same-day shipping if ordered before 3:00 pm EST. Our customer service team is just a call or click away, available to offer technical help or source hard-to-find products. Over the decades we've fine-tuned the balance between inventory, pricing and customer service, and can help you select precisely what you need to get the job done right. Our manufactured products are designed to meet the highest quality standards or provide the best price on the market, sometimes both!

26,000+

INDUSTRIAL PRODUCTS

6

INDUSTRY BRANDS

1960

YEAR FOUNDED

5

WAREHOUSES

90+

ASSOCIATES

23,000+

STOCKED SKU'S IN THE USA



**Depend on us to tool your world and deliver
the competitive edge your business needs to stay ahead!**



Requires a
balancing
machine

WITH 4
COOLANT
PORTS

BALANCEABLE SHRINK FIT TOOLING

- ✓ With threaded holes on holders over 6mm I.D. in order to balance.
- ✓ Improved balance design with no moving pieces.
- ✓ Low Centrifugal Forces due to low holder mass.
- ✓ Maximum gripping power with exceptional concentricity.
- ✓ Improved concentricity 0.0001"/0.003mm
- ✓ Chip load distributed evenly along cutting edge of tool which results in longer tool life.
- ✓ Constructed of H13 Tool Steel for exceptional durability and cycle life. With proper use, toolholder life should exceed that of standard end mill holders.
- ✓ Tool is gripped 360° along the entire length of bore resulting in an evenly distributed clamping force.
- ✓ Short projections are possible because no mechanical clamping devices are used. This results in greater rigidity and resistance to bending.
- ✓ Simple and fast to use. The total time elapsed to remove one cutting tool and insert another is less than 10 seconds.
- ✓ Through-spindle coolant capability.
- ✓ Coolant through holders require no special backup screws or seals. The fit between the I.D. of the tool holder and cutting tool shank forms the seal, preventing the coolant from flowing anywhere else except through the coolant ports. Coolant ports can be closed with a 3mm set screw. The use of Heat Shrink Tooling allows for greater speeds and feeds, better finishes, increased tool life, and increased productivity due to its High Speed Machining capability and simplicity of use.

Note: No coolant ports or threaded balance holes on holders under 6mm I.D.

Shrink Fit Holders

CAT40 Shrink Fit Holders With Coolant Ports



- Holders are balanceable with a balancing machine
- Balanced to G2.5 at 30,000rpm
- 4 threaded Coolant ports in the nose, can be closed with a 3mm set screw
- Maximum gripping power with exceptional concentricity
- TIR $\leq 0.0001'' / 0.003\text{mm}$
- AT2 Taper Accuracy
- Tool is gripped 360° along the entire length of bore resulting in an evenly distributed clamping force
- Material: H13 Tool Steel
- The hot hardness (hot strength) of H13 resists thermal fatigue cracking which occurs as a result of cyclic heating and cooling cycles
- RFID chip hole

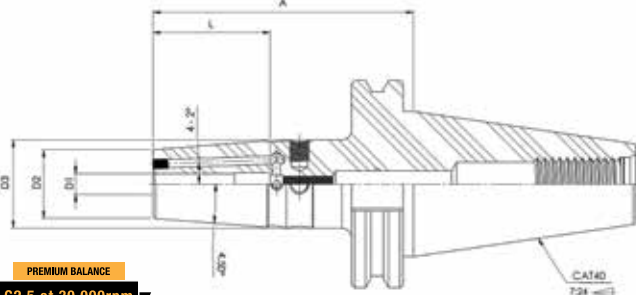

Taper	Hole Dia. (D1)	Gage Length (A)	D2	D3	L	Code No.
Inch						
CAT40	1/8"	3.15"	0.59"	0.787"	0.35"	541838
CAT40	3/16"	3.15"	0.59"	0.787"	0.47"	541840
CAT40	1/4"	3.15"	0.83"	1.06"	1.42"	541842
CAT40	1/4"	6.30"	0.83"	1.06"	1.42"	541844
CAT40	5/16"	3.15"	0.83"	1.06"	1.42"	541846
CAT40	5/16"	6.30"	0.83"	1.06"	1.42"	541848
CAT40	3/8"	3.15"	0.94"	1.26"	1.65"	541850
CAT40	3/8"	6.30"	0.94"	1.26"	1.65"	541852
CAT40	1/2"	3.15"	0.94"	1.26"	1.65"	541854
CAT40	1/2"	6.30"	0.94"	1.26"	1.65"	541856
CAT40	5/8"	3.15"	1.06"	1.34"	1.97"	541858
CAT40	3/4"	3.15"	1.30"	1.65"	2.05"	541862
CAT40	3/4"	6.30"	1.30"	1.65"	2.05"	541864
CAT40	1"	3.94"	1.73"	2.09"	2.28"	541866
CAT40	1"	6.30"	1.73"	2.09"	2.28"	541868
CAT40	1-1/4"	3.94"	1.73"	2.09"	2.28"	541870
CAT40	1-1/4"	6.30"	1.73"	2.09"	2.28"	541872
Metric						
CAT40	4mm	80mm	15mm	20mm	12mm	541802
CAT40	6mm	80mm	21mm	27mm	36mm	541806
CAT40	6mm	160mm	21mm	27mm	36mm	541808
CAT40	8mm	80mm	21mm	27mm	36mm	541810
CAT40	8mm	160mm	21mm	27mm	36mm	541812
CAT40	10mm	80mm	24mm	32mm	42mm	541814
CAT40	10mm	160mm	24mm	32mm	42mm	541816
CAT40	12mm	80mm	24mm	32mm	47mm	541818
CAT40	12mm	160mm	24mm	32mm	47mm	541820
CAT40	16mm	80mm	27mm	34mm	50mm	541822
CAT40	16mm	160m	27mm	34mm	50mm	541824
CAT40	20mm	80mm	33mm	42mm	52mm	541826
CAT40	25mm	100mm	44mm	53mm	58mm	541830
CAT40	32mm	100mm	44mm	53mm	58mm	541834

CAT50 Shrink Fit Holders With Coolant Ports



- Holders are balanceable with a balancing machine
- Balanced G2.5 at 30,000rpm
- 4 threaded Coolant ports in the nose, can be closed with a 3mm set screw
- Maximum gripping power with exceptional concentricity
- TIR $\leq 0.0001'' / 0.003\text{mm}$ with tool shrunk in holder
- AT2 Taper Accuracy
- Tool is gripped 360° along the entire length of bore resulting in an evenly distributed clamping force
- Material: H13 Tool Steel
- The hot hardness (hot strength) of H13 resists thermal fatigue cracking which occurs as a result of cyclic heating and cooling cycles
- RFID chip hole

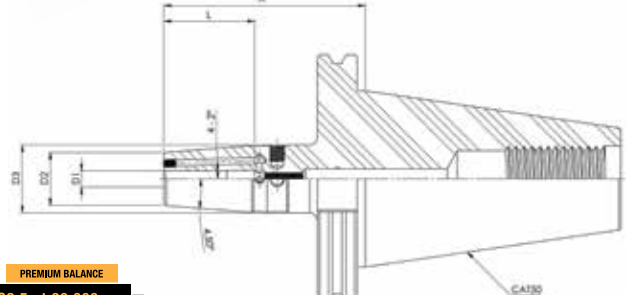

Taper	Hole Dia. (D1)	Gage Length (A)	D2	D3	L	Code No.
Inch						
CAT50	1/4"	3.15"	0.83"	1.06"	1.42"	541932
CAT50	1/4"	6.30"	0.83"	1.06"	1.42"	541934
CAT50	5/16"	3.15"	0.83"	1.06"	1.42"	541936
CAT50	3/8"	3.15"	0.94"	1.26"	1.65"	541940
CAT50	3/8"	6.30"	0.94"	1.26"	1.65"	541942
CAT50	1/2"	3.15"	1.06"	1.34"	1.65"	541944
CAT50	1/2"	6.30"	0.94"	1.26"	1.65"	541946
CAT50	5/8"	3.15"	1.06"	1.34"	1.97"	541948
CAT50	5/8"	6.30"	1.06"	1.34"	1.97"	541950
CAT50	3/4"	3.15"	1.30"	1.65"	2.05"	541952
CAT50	3/4"	6.30"	1.30"	1.65"	2.05"	541954
CAT50	1"	3.94"	1.73"	2.09"	2.28"	541956
CAT50	1"	6.30"	1.73"	2.09"	2.28"	541958
CAT50	1-1/4"	3.94"	1.73"	2.09"	2.28"	541960
CAT50	1-1/4"	6.30"	1.73"	2.09"	2.28"	541962
Metric						
CAT50	6mm	80mm	21mm	27mm	36mm	541900
CAT50	6mm	160mm	21mm	27mm	36mm	541902
CAT50	8mm	80mm	21mm	27mm	36mm	541904
CAT50	8mm	160mm	21mm	27mm	36mm	541906
CAT50	10mm	80mm	24mm	32mm	42mm	541908
CAT50	10mm	160mm	24mm	32mm	42mm	541910
CAT50	12mm	80mm	24mm	32mm	47mm	541912
CAT50	12mm	160mm	24mm	32mm	47mm	541914
CAT50	16mm	80mm	27mm	34mm	50mm	541916
CAT50	16mm	160mm	27mm	34mm	50mm	541918
CAT50	20mm	80mm	33mm	42mm	52mm	541920
CAT50	25mm	100mm	44mm	53mm	58mm	541924
CAT50	32mm	100mm	44mm	53mm	58mm	541928

BT30 Shrink Fit Holders With Coolant Ports



- Holders are balanceable with a balancing machine
- Balanced G2.5 at 30,000rpm
- 4 Coolant ports in the nose
- For maximum gripping power with exceptional concentricity
- TIR of $\leq 0.0001'' / 0.003\text{mm}$ with tool shrunk in holder
- AT2 Taper Accuracy
- Tool is gripped 360° along the entire length of bore resulting in an evenly distributed clamping force
- Material: H13 Tool Steel
- The hot hardness (hot strength) of H13 resists thermal fatigue cracking which occurs as a result of cyclic heating and cooling cycles
- RFID chip hole

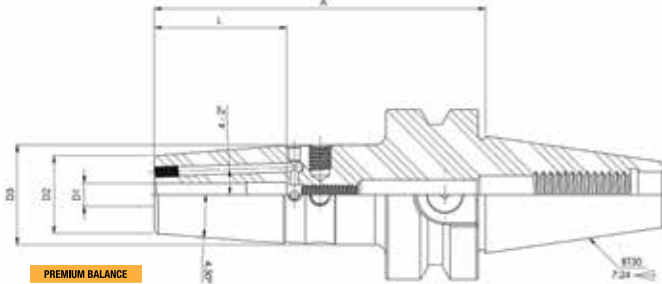

PREMIUM BALANCE
G2.5 at 30,000rpm
CERTIFICATE INCLUDED

Taper	Hole Dia. (D1)	Gage Length (A)	D2	D3	L	Code No.
Inch						
BT30	1/8"	3.15"	0.39"		0.35"	542414
BT30	3/16"	3.15"	0.39"		0.47"	542416
BT30	1/4"	3.15"	0.83"	1.06"	1.42"	542418
BT30	3/8"	3.15"	0.94"	1.26"	1.65"	542422
BT30	1/2"	3.15"	0.94"	1.26"	1.65"	542424
Metric						
BT30	4mm	80mm	10mm		12mm	542402

Coolant Port Screws



Description	Code No.
4pcs per Package	541801

BT40 Shrink Fit Holders With Coolant Ports



- Holders are balanceable with a balancing machine
- Balanced G2.5 at 30,000rpm
- 4 Coolant ports in the nose
- For maximum gripping power with exceptional concentricity
- TIR of $\leq 0.0001'' / 0.003\text{mm}$ with tool shrunk in holder
- AT2 Taper Accuracy
- Tool is gripped 360° along the entire length of bore resulting in an evenly distributed clamping force
- Material: H13 Tool Steel
- The hot hardness (hot strength) of H13 resists thermal fatigue cracking which occurs as a result of cyclic heating and cooling cycles
- RFID chip hole

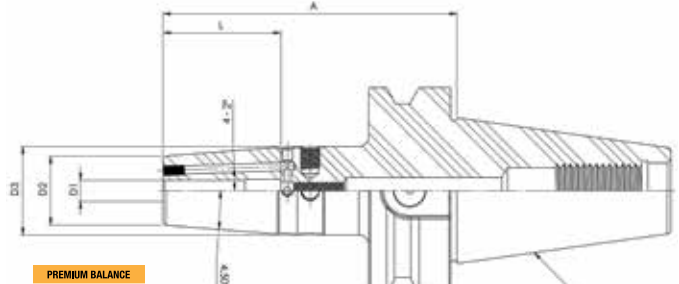

PREMIUM BALANCE
G2.5 at 30,000rpm
CERTIFICATE INCLUDED

Taper	Hole Dia. (D1)	Gage Length (A)	D2	D3	L	Code No.
Inch						
BT40	3/16"	3.54"	0.39"		0.47"	542466
BT40	1/4"	3.54"	0.83"	1.06"	1.42"	542468
BT40	1/4"	6.30"	0.83"	1.06"	1.42"	542470
BT40	3/8"	3.54"	0.94"	1.26"	1.65"	542476
BT40	1/2"	3.54"	1.06"	1.34"	1.65"	542480
BT40	1/2"	6.30"	1.06"	1.34"	1.65"	542482
BT40	3/4"	3.54"	1.30"	1.65"	2.05"	542488
BT40	3/4"	6.30"	1.30"	1.65"	2.05"	542490
BT40	1"	3.94"	1.73"	2.09"	2.28"	542492
BT40	1-1/4"	3.94"	1.73"	2.09"	2.28"	542496
Metric						
BT40	6mm	90mm	21mm	27mm	36mm	542432
BT40	8mm	90mm	21mm	27mm	36mm	542436

Shrink Fit Holders

HSK63A Shrink Fit Holders With Coolant Ports



- Holders are balanceable with a balancing machine
- Balanced G2.5 at 30,000rpm
- 4 Coolant ports in the nose
- For maximum gripping power with exceptional concentricity
- TIR of $\leq 0.0001'' / 0.003\text{mm}$ with tool shrunk in holder
- AT2 Taper Accuracy
- Tool is gripped 360° along the entire length of bore resulting in an evenly distributed clamping force
- Material: H13 Tool Steel
- The hot hardness (hot strength) of H13 resists thermal fatigue cracking which occurs as a result of cyclic heating and cooling cycles
- RFID chip hole

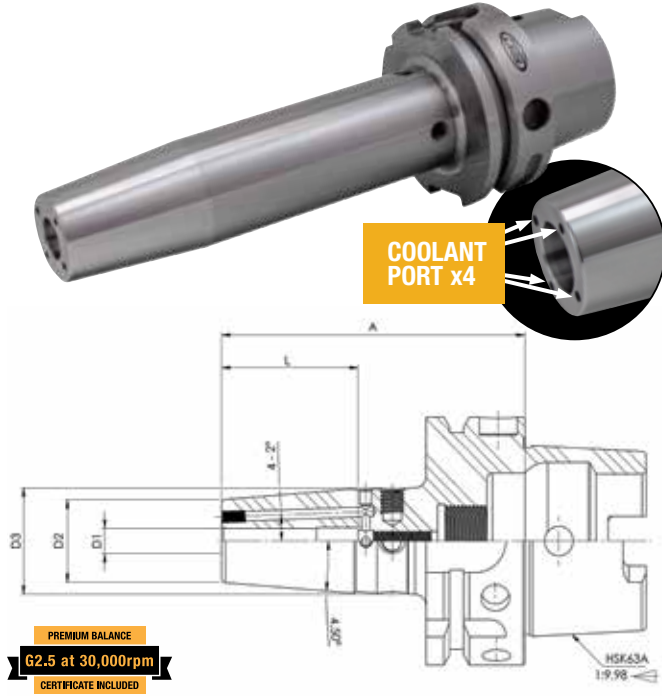

Taper	Hole Dia. (D1)	Gage Length (A)	D2	D3	L	Code No.
Inch						
HSK63A	1/8"	3.15"	0.59"	0.787"	0.35"	546338
HSK63A	3/16"	3.15"	0.59"	0.787"	0.47"	546340
HSK63A	1/4"	3.15"	0.826"	1.06"	1.42"	546342
HSK63A	1/4"	6.30"	0.83"	1.06"	1.42"	546344
HSK63A	5/16"	3.15"	0.826"	1.06"	1.42"	546346
HSK63A	3/8"	3.35"	0.94"	1.26"	1.65"	546350
HSK63A	3/8"	6.30"	0.94"	1.26"	1.65"	546352
HSK63A	1/2"	3.54"	1.06"	1.34"	1.65"	546354
HSK63A	1/2"	6.30"	1.06"	1.34"	1.65"	546356
HSK63A	5/8"	3.74"	1.06"	1.34"	1.97"	546358
HSK63A	5/8"	6.30"	1.06"	1.34"	1.97"	546360
HSK63A	3/4"	3.94"	1.30"	1.65"	2.05"	546362
HSK63A	3/4"	6.30"	1.30"	1.65"	2.05"	546364
HSK63A	1"	4.53"	1.73"	2.09"	2.28"	546366
HSK63A	1"	6.30"	1.73"	2.09"	2.28"	546368
HSK63A	1-1/4"	4.72"	1.73"	2.09"	2.28"	546370
HSK63A	1-1/4"	6.30"	1.73"	2.09"	2.28"	546372
Metric						
HSK63A	3mm	80mm	15mm	20mm		546300
HSK63A	4mm	80mm	15mm	20mm	12mm	546302
HSK63A	5mm	80mm	15mm	20mm	15mm	546304
HSK63A	6mm	80mm	21mm	27mm	36mm	546306
HSK63A	6mm	160mm	21mm	27mm	36mm	546308
HSK63A	8mm	80mm	21mm	27mm	36mm	546310
HSK63A	10mm	85mm	24mm	32mm	42mm	546314
HSK63A	12mm	90mm	24mm	32mm	47mm	546318
HSK63A	16mm	95mm	27mm	34mm	50mm	546322
HSK63A	20mm	100mm	33mm	42mm	52mm	546326
HSK63A	25mm	115mm	44mm	53mm	58mm	546330
HSK63A	32mm	120mm	44mm	53mm	58mm	546334

HSK100A Shrink Fit Holders With Coolant Ports



- Holders are balanceable with a balancing machine
- Balanced G2.5 at 30,000rpm
- 4 Coolant ports in the nose
- For maximum gripping power with exceptional concentricity
- TIR of $\leq 0.0001'' / 0.003\text{mm}$ with tool shrunk in holder
- AT2 Taper Accuracy
- Tool is gripped 360° along the entire length of bore resulting in an evenly distributed clamping force
- Material: H13 Tool Steel
- The hot hardness (hot strength) of H13 resists thermal fatigue cracking which occurs as a result of cyclic heating and cooling cycles
- RFID chip hole

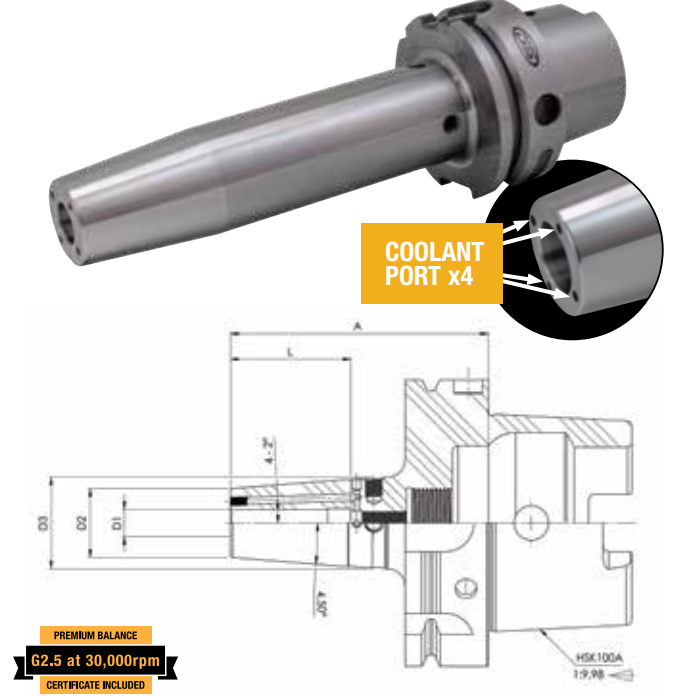

Taper	Hole Dia. (D1)	Gage Length (A)	D2	D3	L	Code No.
Inch						
HSK100A	1/4"	3.35"	0.826"	1.06"	1.42"	546432
HSK100A	5/16"	3.35"	0.826"	1.06"	1.42"	546436
HSK100A	3/8"	3.54"	0.94"	1.26"	1.65"	546440
HSK100A	3/8"	6.30"	0.94"	1.26"	1.65"	546442
HSK100A	1/2"	3.74"	1.06"	1.34"	1.65"	546444
HSK100A	1/2"	6.30"	1.06"	1.34"	1.65"	546446
HSK100A	5/8"	3.94"	1.06"	1.34"	1.97"	546448
HSK100A	5/8"	6.30"	1.06"	1.34"	1.97"	546450
HSK100A	3/4"	4.13"	1.30"	1.65"	2.05"	546452
HSK100A	3/4"	6.30"	1.30"	1.65"	2.05"	546454
HSK100A	1"	4.53"	1.73"	2.09"	2.28"	546456
HSK100A	1"	6.30"	1.73"	2.09"	2.28"	546458
HSK100A	1-1/4"	4.72"	1.73"	2.09"	2.28"	546460
HSK100A	1-1/4"	6.30"	1.73"	2.09"	2.28"	546462



Superior performance tool holding and workholding solutions when speed and accuracy matter most.

GS Tooling is an industry leader in precision tooling where high-performance and stringent quality standards are paramount. Tool your World with GS Tooling End Mill Holders, Collet Chucks & Collets, Retention Knobs, Vises & Workholding, Live Centers, Angle Heads, Carbide End Mills and more!



Tool Holding



Angle Heads & Driven Tooling



Cutting Tools



Vises & Workholding



Welcome to the **Sowa** family!



Superior performance tool holding and workholding solutions when speed and accuracy matter most.

ASIMETO

High-performance precision measuring and inspecting solutions.



High-performance cutting tools including end mills, drills, taps and indexables.

SKODA

High Value production grade live centers.

narex

Exclusive line of value boring heads.



A wide product range of economic tooling for general purpose applications.



With this line-up, Sowa Tool is uniquely qualified to serve all your needs under one roof. Ask us how Sowa can tool your world and provide the competitive edge for your business.

Distributed by:



COMPLETE METALWORKING SOLUTIONS

(800) 991-4225

www.ahbinc.com

ISO Certified

customerservice@ahbinc.com

Sowa
TOOLING YOUR WORLD.

Sowa Tool & Machine Co. Ltd.

Canadian Head Office
500 Manitou Drive, Kitchener, ON, N2C 1L3

North Carolina Office
101-137 Overhill Drive, Mooresville, NC 28117