

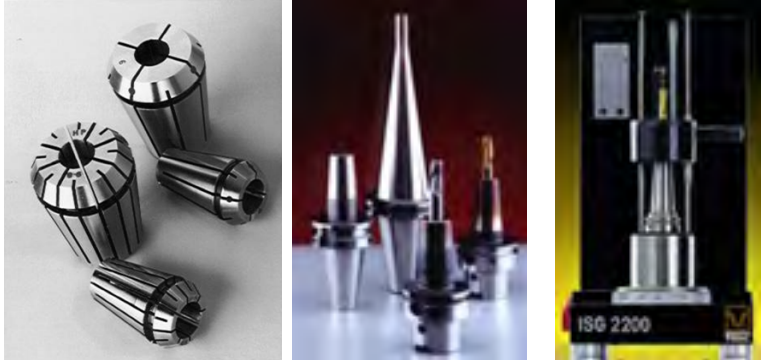

We sell Solutions!

SMITH TOOL

THE DIFFERENCE BETWEEN
A TOOLHOLDER AND A T.M. SMITH
TOOLHOLDER IS *WE SELL SOLUTIONS,*
SUPPORT AND SERVICE.



PRECISION TOOL HOLDERS

Quick Change Tapping
Shrinker® Tool Holders
HSK Tool Holders
Special Applications
Quick Change Drilling

SPECIAL DESIGNS AVAILABLE TO SUIT YOUR APPLICATION!

Contact our engineering department with your specifications, samples or drawings. We have over 120 years combined manufacturing and engineering experience to serve you.

www.tmsmith.com

**“It’s what’s on the
inside that matters”**

MQL

T.M. Smith is the industry
leader in MQL technology.

Minimum Quantity
Lubricant is a **GREEN**
technology that reduces
environmental issues and
improves tool life.

T.M. Smith’s engineering
team will work with you to
make sure your new **GREEN**
application is a success. We

offer both single channel and dual channel MQL tool holders.

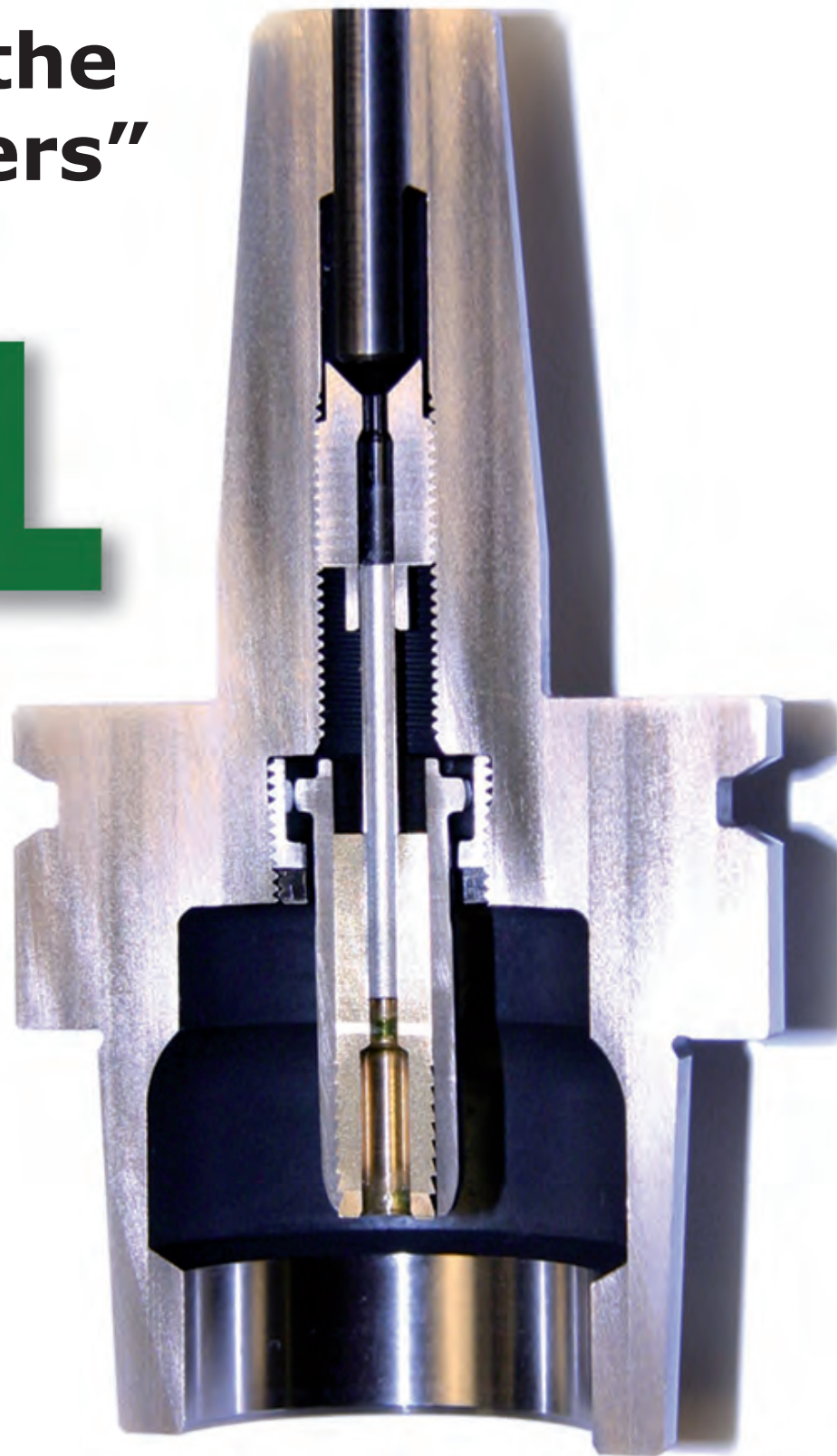

At T.M. Smith, we sell solutions.

50 Years of engineered solutions



T.M. SMITH TOOL INTERNATIONAL CORPORATION

A Heritage of Innovation

In 1957, my Grandfather, T.M. Smith – inventor, engineer, businessman – founded a tool company that pioneered the development of Quick-Change tool holding systems in North America. His, and our, success was based on listening to customers and meeting their needs with products of the highest attainable quality.

Both of these ideas were far ahead of their time, but his vision has been validated many times over as the rest of the world strives to achieve the goals T.M. Smith set for himself and his company in 1957. The standards and methods he established then are still the cornerstone of the quality programs we have in place today.

Today, T.M. Smith is the world's leading producer of Quick-Change toolholding systems for drilling and tapping in both high-volume and small-lot production. We produce a best in class line of HSK, CAT, and Shrinker holders to meet even the most demanding applications. We offer over 95% off the shelf delivery on standard configurations and can rapidly produce complete specials to meet your

needs.

We have achieved that success by listening to our customers and investing in technology that helps them improve their productivity. During the three generations of family ownership the success of T.M. Smith Tool has been based on listening. Listening to our customers and listening to our employees. We believe even today this simple principle allows us to differentiate ourselves from the many companies we compete with on a daily basis.



We understand that in today's crowded marketplace our customers have options when making tooling purchases. Supplying world-class engineered precision spindle tooling solutions is a must for any legitimate supplier in today's market. We have assembled a world class team of professionals at all levels of our company that embrace the concept of speed on behalf of the customer.

We appreciate your interest in our company and look forward to helping you achieve your goals through working together.

Best Regards,

David Smith
President

We Sell Solutions

- **Shrinker® HSK & VFLANGE**
- **MQL Coolant Toolholders**
- **HSK Toolholders**
- **Collets & Collet Chucks**
- **Quick-Change Drill Holders**
- **Quick-Change Tap Holders**
- **Accessories and Components**

T.M. Smith Tool Corporate headquarters and manufacturing facility located in Mt. Clemens, Michigan.



NOTE: Ball-Lock™, Smith-Lock®, Smith Super Taper™, SST™, Taper-Lock™, Tap Sentry®, Tru-Taper® and DURAFLOAT® are Trademarks of T.M. Smith Tool International Corporation.

TABLE OF CONTENTS



TAPPING & REAMING SYSTEMS

• Floating Holder Selection Information	05
• Smith Sync Tap Holder for Rigid Tapping	06
• SITH Cartridge Style Holder, Modular Shank	07
• FITH-II Quick-Change Floating Holder, Modular Shank	07
• CSTD-T Cartridge Style Tension Holder	08
• SITC Short Tension & Compression, Modular Shank	08
• Quick Change Tap Holding Tooling Tree	09
• FITH-II Design Information	11
• FITH-II Floating Tap Holder, Acme Shank	12
• FITH-II Floating Tap Holder, Rotary Coolant	12
• FITH-II Quick-Change Floating Tap Holder, Morse Taper	13
• FITH-II Floating Tap Holder, Jacobs Taper Mount	13
• FITH-II Quick-Change Floating Tap Holder, Straight Shank	14
• FITH-II Quick-Change Floating Tap Holder, HSK Shank	14
• FITH-II Single Angle Collet Floating Holder, Straight Shank	15
• FITH-II Single Angle Collet Floating Holder, Acme Shank	15
• ACTH Adjustable T&C Acme Shank Tap Holder	16
• ACTH Adjustable T&C Tap Holder Straight Shank	16
• LCTH T&C with Radial Float, Acme Shank	17
• LCTH T&C with Radial Float, Morse Taper Shank	18
• CCTH Close-Center Tap Holder	19
• SITH Rigid Quick-Change, High Pressure Coolant	21
• Positive Drives for Reamer Holders & Adapters	22

TAP ADAPTERS

• Tap Adapter Selection Chart	25
• NTA—ANSI Tap Adapter Thru-Coolant	27
• <i>Tang Drive</i> NTA—ANSI Tap Adapter Thru-Coolant	28
• NTA—ISO 529 / 2283 Metric Tap Adapter Thru-Coolant	29
• NTA—DIN 371 / 376 Tap Adapter Thru-Coolant	30
• NTER—ANSI-C Tap Adapter Extended Range Thru-Coolant	31
• <i>Tang Drive</i> TA—ANSI Torque Control Adapter Thru-Coolant	32
• CSTA-NCI Collet Style Tap Adapter	33
• NTLA—ANSI Adjustable Length Tap Adapter Thru-Coolant	34
• NTLA—Tension Tap Adapter	35
• TMS-EXT Adapter Length Extensions	36
• CSTA w/ Coolant Inducer Collet-Style Tap Adapter for Coolant	37

COLLETS

• ER Metric Collets	39
• ER Inch Collets	40
• Rubber Sealed ER Collets	41
• Steel Sealed ER Collets	42
• ER Tap Collets – ANSI	43
• SG10 (TG100) Collets	44

• SG15 (TG150) Collets	45
• DA Collets	46
• Collet Sets—SA, DA & TG	47
• Collet Nuts—Standard & Coolant Disk	48
• DA Coolant Nuts	49
• Coolant Disk for Collet Nuts	50

SPECIAL MACHINE DRILLING

51

Quick-Change Collet Chuck Drill Holders

• Quick-Change Drill Holding Tooling Tree	52
• Tru-Taper®, Smith-Lock®, Collet Chucks	54
• OSA Over Spindle Adapter, Smith-Lock®	55
• Tru-Taper®, Ball Lock™, Collet Chucks	56
• OSA Over Spindle Adapter, Ball Lock™	57
• SST™ Smith Super-Taper™, Collet Chucks	58
• OSA Over Spindle Adapter, Smith Super-Taper™ only	58
• Sealed Ball Lock™ Tooling Tree	59
• Tru-Taper®, Sealed Ball Lock™, Collet Chucks	60
• OSA Over Spindle Adapter, Sealed Ball Lock™ only	61
• Acme Threaded Shank Collet Chucks	62
• Smith Grip Precision Chucks	63
• Quick Change Sleeve System	64
• Quick Change Sleeve Adapters	65
• Preset Adapters for Drill Holders	65
• Positive Drives for Drill Holders	66
• Smith-Lock® Quick-Change Conversion Nuts	67
• Ball-Lock™ Quick-Change Conversion Nuts	67
• Sealed Ball-Lock™ Quick-Change Conversion Nuts	68
• Standard Acme Adjusting Nuts	68
• Coolant Inducers	69
• Wrenches—Standard & Torque	70
• Drill Holder Locking Fixtures	71
• Taper Locking Fixtures (Cat, HSK)	71

TABLE OF CONTENTS



SHRINK FIT TOOLING SYSTEMS 72

CNC IDENTIFICATION SYSTEM 83

HSK Adapters

- HSK Form "A" Adapter DIN Design 75

SHRINK FIT MACHINES 76

Heating Units

- ISG 2200-WK Water Cooling 76
- ISG 2300-WK Water Cooling 77
- ISG-2200 208V Single Station 79
- Cooling Station 80
- ISG-3200 400V Single Station with Cooling 82
- Induction Coils 83
- Coil Location Plates 84
- Tool Holders 84
- Cooling Adapters 84
- Cutting Tool Cooling Plate 84

CNC SYSTEMS 85

- Cat & BT Collet Chucks 86
- Cat-40 End Mill Adapters 87
- Cat-50 End Mill Adapters 88
- Soft Blanks 89
- HP3 Precision Drill Chuck 90
- Drill Chucks (Key & Keyless) 91
- SITC Short Style Tension & Compression Holders 92
- Shell Mill Adapters 93
- SITH Rigid Tapping System 94
- ACTH Adjustable Tension / Compression Holders 94
- HSK63A End Mill Extensions 95
- ER and DA Straight Shank Collet Chucks 96

TERMS & GENERAL INFORMATION 97

PART NUMBER INDEX 98

TAPPING & REAMING SYSTEMS



The special machine tapping tools in this catalog will help you improve the productivity of your special machines and the quality of your products. With every T.M. Smith Tool product you get: Technology developed, tested and perfected. Technology selected and optimized for real-world special machine tapping. Technology supported by the T.M. Smith service policy and nationwide network of trained stocking distributors. There is no substitute for quality. That's why T.M. Smith tool is now the industry's leading comprehensive single-source supplier for all your quick-change high speed spindle tooling systems.

PRODUCTS IN THIS SECTION:

- FITH-II Floating Tapping & Reaming Holders
- FITH-II RCI Floating Rotary Coolant Fed Holders
- ACTH Adjustable Tension / Compression Tap Holder
- LCTH Tension / Compression with Radial Float Tap Holders
- CCTH Close-Center Tap Holder with Tension Acme Shank

SPECIAL DESIGNS AVAILABLE TO SUIT YOUR APPLICATION!

⇒ Contact our engineering department with your specifications, samples or drawings. We have over 120 years combined manufacturing and engineering experience to serve you. You can email us at engineering@tmsmith.com or visit our web site at <http://www.tmsmith.com>.

ERROR PROOFING

⇒ Tap Adapters are available with special error proofing options to suit your specific application.



Why use a holder with radial float?

A holder that provides radial float should be selected for tapping or reaming applications where the hole that is to be tapped, or reamed, does not lie exactly on the machine spindle centerline. Typical examples of this may include the following types of equipment or operations.

- Transfer line type equipment
- Dial type machines
- Reaming through bushing plates that are not aligned with the spindle's centerline
- Tapping machines that only tap a hole that is prepared somewhere else
- Tapping castings that have "As cast holes" and are not qualified by additional drilling on the same machine where tapping takes place.



However the misalignment occurs, it must be compensated for before tapping or reaming to provide optimum results.

In tapping, a holder that provides radial float, allows the tap to find the center of the prepared hole and produce a higher quality thread and better tap life. No binding to the tap, or angularity of the tapped hole to the spindle centerline is introduced by the tapping operation if the holder compensates for the misalignment.

In reaming, the same things are true. Holes are sometimes guided by bushing plates that are not in alignment with the spindle's centerline and would cause binding, or rubbing, of the reamer going through the bushing. The floating holder compensates for this.

On applications where there is no bushing plate used, the holder must allow the reamer to "Find" the center of the hold or "Bell Mouthing", which is an imperfection to the diameter at the entrance of the reamed hole can occur. The reamer, without a radial floating holder, has to engage a sufficient amount of the reamer into the hole before it stabilizes in cut. During this time it can produce an oversized hole at the entrance, or "Bell Mouthing".

Either tapping or reaming works best when the cutting tool is not forced in any direction, but allowed to cut freely on it's own.

Why use a length compensating tap holder with radial float?

The LCTH tap holder provides both radial float and length compensation for tapping operations. It has the ability to "Float" parallel, off the machine spindle's centerline, to the center of the hole to be tapped. It also provides compensation, tension and compression, for spindle speeds and feed rates not matched to the pitch of the tap you are using. The two features perform separate and distinct functions.



1. Radial float is desired when the hole you are trying to tap does not fall on the same centerline as the spindle. This happens when transfer type machinery produces a hole at one station and then another station does the tapping operation. Some misalignment of the holes to be tapped can occur when the pallet fixture moves from the drilling station to the tapping station. The floating holder compensates for the misalignment. Another example is when tapped holes are made in cast parts where the holes are not finished machined in the same fixturing as where the holes are to be tapped. This is sometimes referred to as tapping "As Cast Holes". For a high quality thread to be produced, the tap must find the center of the hole and then tap without any angularity or binding of the tap. Floating holders accommodate the misalignment. Tap life will be improved as well as a higher quality thread being produced.
2. Length compensation in the holder is the ability to shorten, or lengthen, itself during the tapping cycle. This allows the tap to feed at the proper pitch or its own pitch, without any pushing or pulling forces on the tap. Pushing or pulling, (compression or tension), actions will result in the flank angles of the thread to be shaved and distorted. This is a common source of oversized tapped holes, or holes where there is crest damage to the thread form. Some sources of the mismatch of feeds and speeds may include worn components on the machine, or the inability to accurately control the feed and speed of the spindle to the pitch of the tap.
3. Compression is necessary when using a torque control type of tap adapter. This is a tap adapter that has a clutch inside it. When a torque value is reached during tapping the clutch disengages from driving the tap and the tap stops rotating. The torque value is usually set at a pressure just before the tap breaks. The clutch re-engages on reverse of the spindle and backs the tap out of the hole. If the clutch disengages during the forward tapping operation, the holder must have the ability to compress on itself to compensate for the still advancing spindle. Not having this feature will result in a crash.

SMITH SYNC TAP HOLDER FOR RIGID TAPPING



- Holders design compensates for minute mismatch between machine feed rate and tap pitch.
- All Holders have thru coolant capability rated for 1000 PSI or 69 BAR.
- Coolant pipes offered separately
- ALL Standard Shanks available upon request.

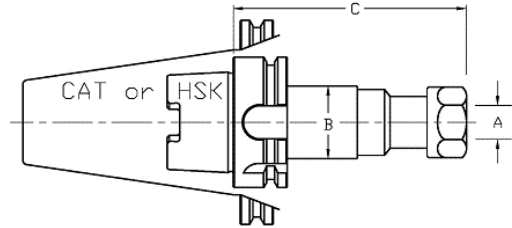

- Standard Smith Sync .



PART NO..	A	B	C	COLLET
C40SA20511SS	#8-1/2"	1.38	5.11	ER20
C40SA32511SS	#8-13/16"	1.96	5.11	ER32
C50SA20511SS	#8-1/2"	1.38	5.11	ER20
C50SA32511SS	#8-13/16"	1.96	5.11	ER32
H63ASA20475SS	#8-1/2"	1.38	4.75	ER20
H63ASA32475SS	#8-13/16"	1.96	4.75	ER32
H100ASA20488SS	#8-1/2"	1.38	4.88	ER20
H100ASA32488SS	#8-13/16"	1.96	4.88	ER32

- Slim Line Smith Sync Design Also Available With All Standard Shanks.

FLEXIBLE COOLANT TUBES FOR HSK TOOL HOLDERS

- Coolant Tube comes complete with (2) "O" rings and retainer nut.
- HSK Standard requirements for all coolant thru applications.
- Fits all makes of DIN 69893-1 HSK Tool Holders
- Double "O" ring DIN design provides 1 degree minimum compliance with machine spindle.

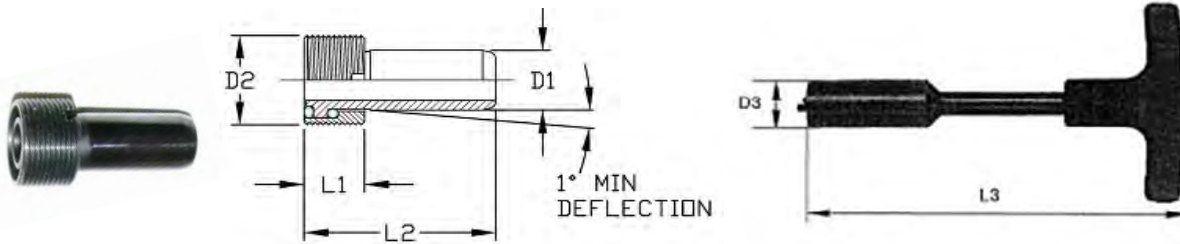

TOOL HOLDER SIZE	COOLANT TUBE NUMBER	D1	D2	L1	L2	TUBE WRENCH NUMBER	D3	L3
HSKA32	HSK32T	6	10x1	5.5	26	HSK32TW	8.5	107
HSKA40	HSK40T	8	12x1	7.5	29.2	HSK40TW	10.5	112
HSKA50	HSK50T	10	16x1	9.5	33	HSK50TW	14.5	117
HSKA63	HSK63T	12	18x1	11.5	36.5	HSK63TW	16.5	122
HSKA80	HSK80T	14	20x1.5	13.5	40	HSK80TW	18	131
HSKA100	HSK100T	16	24x1.5	15.5	44	HSK100TW	22	141

MODULAR TAP HOLDERS



SITH Cartridge Style Tap Holder Coolant Thru for Rigid or Synchronized Tapping Modular Straight Shank for End Mill Holders



Features, Application, Ordering:

- ⇒ Order Adapters Separately, see page 24.
- ⇒ Optional rust resistant chrome finish, add "ST" to the part number.
- ⇒ Specials Available Upon Request
- ⇒ Accepts Bilz, Collis, Universal, Lyndex and many other tap adapters.
- ⇒ "C" Series holders are for tap adapters with coolant inducers only
- ⇒ "M" Series holders are for all standard adapters. "M" Series includes adapter ejector system for easy adapter assembly & removal

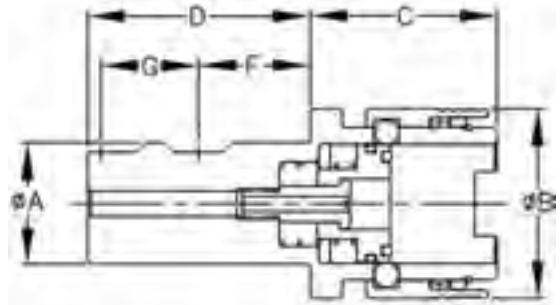

PART NUMBER	TAP RANGE	A DIA.	B DIA.	C	D	F	G	RECOMMENDED ADAPTERS
120-M712*	SIZE 0 0-1/4 HAND	.7500	.92	1.01	2.03	1.005	-	ANY 50-XXX
121-M716	SIZE 1 0-9/16 HAND	1.0000	1.26	1.12	2.28	1.130	1.000	ANY 51-XXX
121-C-51		.7500	1.69	1.25	2.09	1.005	-	ONLY 51-SA16-XXX
122-M720	SIZE 2 5/16-7/8 HAND	1.2500	1.96	1.92	2.28	1.130	1.000	ANY 52-XXX
122-C-52		1.0000		2.09	2.28	1.130	1.000	ONLY 52-SA32-XXX
123-M732*	SIZE 3 3/4-1-3/8 HAND	2.0000	2.91	3.06	3.25	1.505	1.000	ANY 53-XXX

FITH II Quick-Change Floating Quick-Change Tap Holder Modular Straight Shank for End Mill Holders



Features, Application, Ordering:

- ⇒ Thru Coolant Design—Note: Coolant hole in adjusting screw must be smaller than coolant hole in the tap or reamer for high pressure applications. Consult our engineering department before ordering.
- ⇒ Adjustable Centering Mechanism, allows the customer to customize the amount of pressure required to move the tool off center.
- ⇒ For use with machines with synchronized feed and spindle rotation.
- ⇒ Heavy Duty drive pin design.
- ⇒ Order Adapters Separately, see page 24.
- ⇒ Optional rust resistant chrome finish, add "ST" to the part number.
- ⇒ Specials Available Upon Request
- ⇒ Accepts Bilz, Collis, Universal, Lyndex and many other tap adapters.

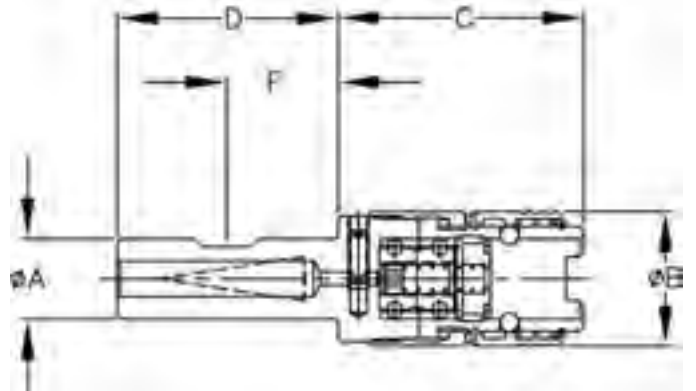

PART NUMBER	TAP RANGE	A DIA.	B DIA.	C	D	F	TOTAL FLOAT
251-50-M712*	SIZE 0 0-1/4 HAND	.7500	.92	1.88	2.03	1.005	.06
253-51-M716*	SIZE 1 0-9/16 HAND	1.0000	1.26	2.29	2.28	1.130	.06
254-52-M720*	SIZE 2 5/16-7/8 HAND	1.2500	1.96	3.37	2.28	1.130	.06
256-53-M732*	SIZE 3 3/4-1-3/8 HAND	2.0000	2.83	4.94	3.25	1.505	.09

MODULAR TAP HOLDERS



CSTH-T Cartridge Style Tap Holder with Tension Modular Straight Shank for End Mill Holders

Features, Application, Ordering:

- ⇒ Order Adapters Separately, see page 24.
- ⇒ Optional rust resistant chrome finish, add "ST" to the part number.
- ⇒ Specials Available Upon Request
- ⇒ Accepts Bilz, Collis, Universal, Lyndex and many other tap adapters.

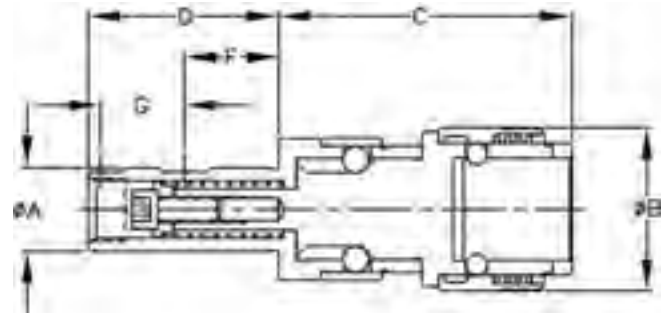

PART NUMBER	TAP RANGE	A DIA.	B DIA.	C	D	F	G	TENSION STROKE
311-C-51-T	SIZE 1 0-9/16 HAND	.7500	1.69	2.17	2.10	1.005	-	.200
312-C-52-T	SIZE 2 5/16-7/8 HAND	1.0000	1.96	3.49	2.28	1.130	1.000	.500

SITC—Short Tension & Compression Quick-Change Tap Holder Modular Straight Shank for End Mill Holders



For Tang Drive Adapters Only!

Features, Application, Ordering:

- ⇒ For use with Tang Drive Adapters Only!
Order Adapters Separately, see page 28.
- ⇒ Hard Start Design: Can be locked out for Full Tension Use.

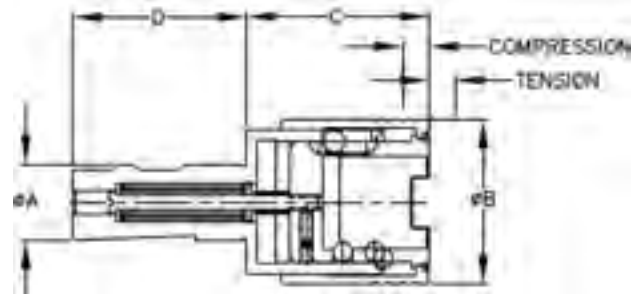

PART NUMBER	TAP RANGE	A DIA.	B DIA.	C	D	TENSION	COMPESSION
741-M716-TC	SIZE 1 0-9/16 HAND	1.0000	1.61	1.76	1.95	.35	.35
742-M716-TC	SIZE 2 5/16-7/8 HAND	1.0000	2.36	2.52	2.00	.59	.59
743-M724-TC	SIZE 3 3/4-1-3/8 HAND	1.5000	3.38	3.85	3.50	.94	.94

QUICK CHANGE TAPPING TOOLING TREE



Straight Bore (Acme) Spindle



FITH-II
Floating
Interchangeable
Tap Holder
Page 11



LCTH
Tension &
Compression
Floating Tap Holder
Page 17



ACTH
Adjustable
Compensation
Tap Holder
Page 16



NTA
Direct Drive
Tap Adapter
Thru Coolant
Page 24



EXT
Tap Adapter
Extension
Page 36



TA
Torque
Control Tap
Adapter
Thru Coolant
Page 32



CSTA
Collet Style
Tap/Reamer
Adapter
Thru Coolant
Page 33



NTLA
Direct Drive
Tap Adapter
Adjustable
Length
Thru Coolant
Page 34



Straight Bore (Acme) Spindle



**CCTH
Close Center
Tap Holder
Page 19**



**SITH
Synchronized
Interchangeable
Tap Holder
Thru Coolant
Page 21**



**EXT
Tap Adapter
Extension
Page 36**



**CSTA
Collet Style
Tap/Reamer
Adapter
Thru Coolant
Page 33**

QUICK CHANGE TAP HOLDERS



Quick Change Tap Holders
Permit 5 Second Change of the
Tap Adapter

Pull Shell to Release

- FITH-II
- LCTH
- SITH



QUICK CHANGE TAP ADAPTERS



Quick Change Tap Adapters
Permit 5 Second Change of the
Tap

Push to Release

- NTA
- NTLA
- NTLRA
- TA



FLOATING HOLDERS



“The result of continuous improvement, taking the best of all worlds and making a superior product.”

David Smith - Chief Operating Officer

The FITH-II radial floating holder employs a 6 ball differential drive system which provides a true round float with no cornering effect. This drive allows for reduced mechanism diameter and increased radial torque. By adding chip shields, coolant thru, coolant flow capabilities and adjustable centering pressure, we have produced the most advanced floating holder the market has seen to date.

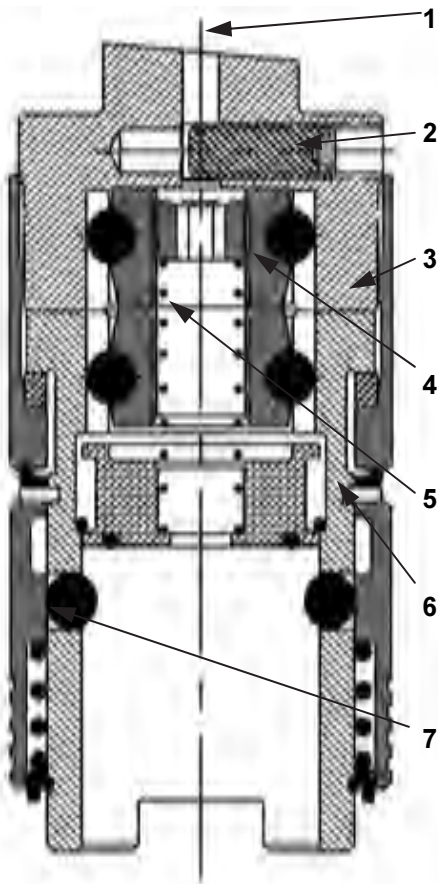

1. High Pressure Coolant Thru

Floating Mechanism is designed to float freely with coolant pressures as high as 1000 PSI.

2. Adjustable Coolant Flow Control

The Flow Control Screw is adjustable to allow even volume of coolant to match the coolant hole in the cutting tool. This reduces back pressure and allows the floating holder to work properly under any coolant flow.

3. Reduced Diameter Mechanism

Redesigned to work with close center cluster spindles or tight work areas.

4. Differential Drive Mechanism

The 6 ball differential drive is designed to provide smooth radial float and eliminate the cornering that most mechanisms create from their drive pin designs. FITH-II is the best holder for fine reaming and honing on the market today.

5. Adjustable Centering Pressure

Provides adjustment to the sensitivity of the float. The option is primarily used on small taps & fine reaming or honing.

6. Chip Shield

Keeps coolant and chips from entering the front of the mechanism.

7. 6 Ball Drive Coupling

T.M. Smith developed the 6 ball drive mechanism in 1957 to provide greater radial torque and longer tool life.

FLOATING HOLDERS



FITH-II Quick-Change Floating Tap & Reamer Holder Acme & Trapezoidal (Metric) Shank



Features, Application, Ordering:

- ⇒ Differential Drive Floating System for Smooth True Float
- ⇒ Thru Coolant Design with Back Pressure Flow Control System
- ⇒ Adjustable Centering Mechanism, allows the customer to customize the amount of pressure required to move the tool off center.
- ⇒ Front Side Chip Shield
- ⇒ Spindle coolant inducers available, see page 69.
- ⇒ For use with machines with synchronized feed and spindle rotation.
- ⇒ Order Adapters Separately, see page 24.
- ⇒ Specials Available Upon Request.
- ⇒ Accepts Bilz, Collis, Universal, Lyndex and many other tap adapters.

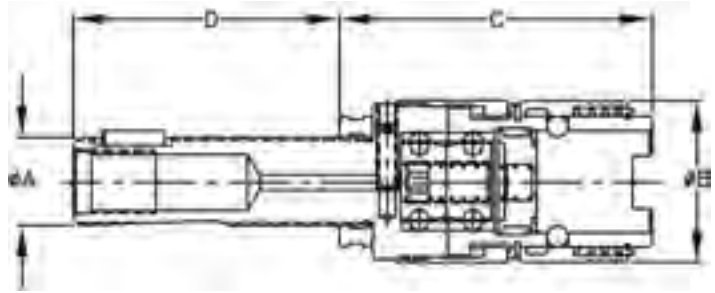

FITH-II Quick-Change Floating with External Radial Coolant Inducer (RCI)

Features, Application, Ordering:

- ⇒ Coolant Pressure Max.750 PSI
- ⇒ Available with 1/8 or 1/4 NPT
- ⇒ RPM limits 5/8-7/8 shank 3600 RPM
1 1/16-1 3/8 shank 2000 RPM
1 7/8 shank 1800 RPM
- ⇒ Specials Available Upon Request.
- ⇒ Note: All RCI's require anti rotate and coolant flow during spindle rotation
- ⇒ To order add to part number RCI-Pipe Thread SIZE
Example: 220-210RCINPT125 (for 1/8 NPT)

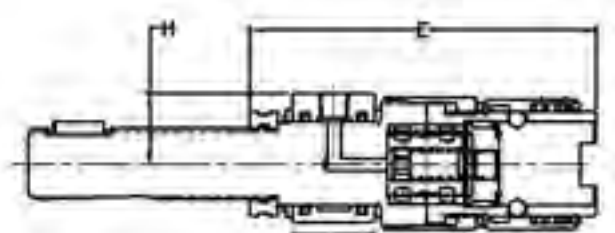
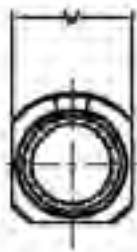

PART NUMBER	TAP RANGE	A ACME	B DIA.	C	D	E FOR RCI	H FOR RCI	W FOR RCI	TOTAL FLOAT	REF. THRU SPDL COOL'T INDUCER			
220-210	SIZE 0 0-1/4 HAND	5/8-16	.92	2.29	2.59	3.75	1.12	1.250	.06	331-4013-SA11			
220-212		3/4-12			2.59					331-4014-20			
220-TR16		TR16 X 1.5MM			2.94					*			
220-TR20		TR20 X 2.0MM			3.06					*			
221-210	SIZE 1 0-9/16 HAND	5/8-16	1.26	2.70	2.59	4.10	1.12	1.250	.06	331-4013-SA11			
221-212		3/4-12			2.59					331-4014-20			
221-214		7/8-12			3.22					331-4016-20			
221-217		1-1/16-12			3.22					332-4016-18			
221-TR20		TR20 X 2.0MM			3.06					*			
221-TR28		TR28 X 2.0MM			3.21					*			
222-217	SIZE 2 5/16-7/8 HAND	1-1/16-12	1.96	3.78	3.22	5.15	1.36	2.000	.06	332-4016-18			
222-222		1-3/8-12			4.22					332-4020-18			
222-TR28		TR28 X 2.0MM			3.21					*			
222-TR36		TR36 X 2.0MM			4.24					*			
223-222	SIZE 3 3/4-1-3/8 HAND	1-3/8-12	2.83	5.35	4.22	6.73	1.36	2.000	.09	332-4020-18			
223-230		1-7/8-12			5.22					6.97	1.50	2.625	332-4020-18
223-TR36		TR36 X 2.0MM			4.24					6.73	1.36	2.000	*

* - Metric spindles must be manufactured for coolant inducer. Spindle inspection is required to supply the proper inducer.

FLOATING HOLDERS



FITH-II Quick-Change Floating Tap & Reamer Holder Morse Taper Shank



Features, Application, Ordering:

- ⇒ Differential Drive Floating System for Smooth True Float
- ⇒ Adjustable Centering Mechanism, allows the customer to customize the amount of pressure required to move the tool off center.
- ⇒ Front Side Chip Shield
- ⇒ For use with machines with synchronized feed and spindle rotation.
- ⇒ Order Adapters Separately, see page 24.
- ⇒ Specials Available Upon Request.
- ⇒ Accepts Bilz, Collis, Universal, Lyndex and many other tap adapters.

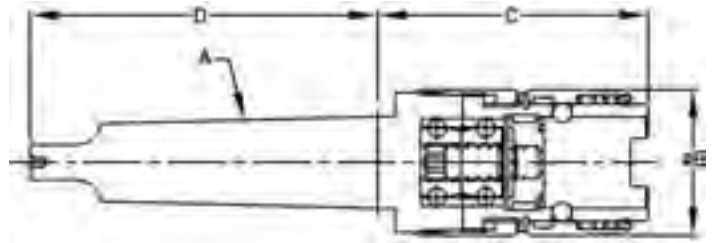

PART NUMBER	TAP RANGE	A MORSE	GAGELINE DIA.	B DIA.	C	D	TOTAL FLOAT
221-302*	SIZE 1 0-9/16 HAND	#2 MORSE	.700	1.26	2.61	2.94	.06
222-303*	SIZE 2 5/16-7/8 HAND	#3 MORSE	.938	1.96	3.56	3.69	.06
222-304*		#4 MORSE	1.231		3.60	4.63	
223-304*	SIZE 3 3/4-1-3/8 HAND	#4 MORSE	1.231	2.83	5.13	4.63	.09

FITH-II Quick-Change Floating Tap & Reamer Holder Jacobs Taper Shank

Features, Application, Ordering:

- ⇒ Differential Drive Floating System for Smooth True Float
- ⇒ Adjustable Centering Mechanism, allows the customer to customize the amount of pressure required to move the tool off center.
- ⇒ Front Side Chip Shield
- ⇒ For use with machines with synchronized feed and spindle rotation.
- ⇒ Order Adapters Separately, see page 24.
- ⇒ Specials Available Upon Request.
- ⇒ Accepts Bilz, Collis, Universal, Lyndex and many other tap adapters.

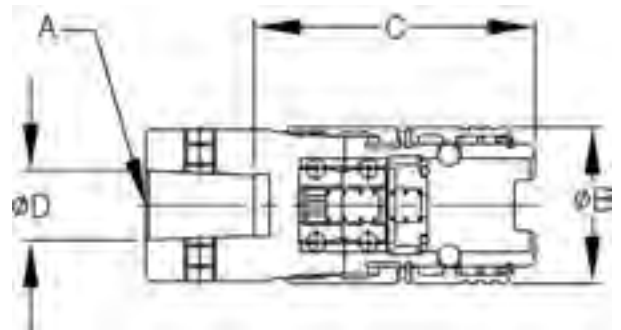

PART NUMBER	TAP RANGE	A JACOBS TAPER	B DIA.	C	D GAGELINE	TOTAL FLOAT
221-501	SIZE 1 0-9/16 HAND	#1 JACOBS	1.26	2.41	.384	.06
221-502		#2 JACOBS		2.27	.559	
221-533		#33 JACOBS		2.29	.624	
222-503*	SIZE 2 5/16-7/8 HAND	#3 JACOBS	1.96	3.50	.811	.06
222-504 JIFFY		#4 JIFFY TAPPER		3.50	1.124	

FITH-II Quick-Change Floating Tap & Reamer Holder Straight Shank & HSK Shank

Features, Application, Ordering:

- ⇒ Differential Drive Floating System for Smooth True Float
- ⇒ Thru Coolant Design with Back Pressure Flow Control System
- ⇒ Adjustable Centering Mechanism, allows the customer to customize the amount of pressure required to move the tool off center.
- ⇒ Front Side Chip Shield
- ⇒ For use with machines with synchronized feed and spindle rotation.
- ⇒ Order Adapters Separately, see page 24.
- ⇒ Specials Available Upon Request.
- ⇒ Accepts Bilz, Collis, Universal, Lyndex and many other tap adapters.

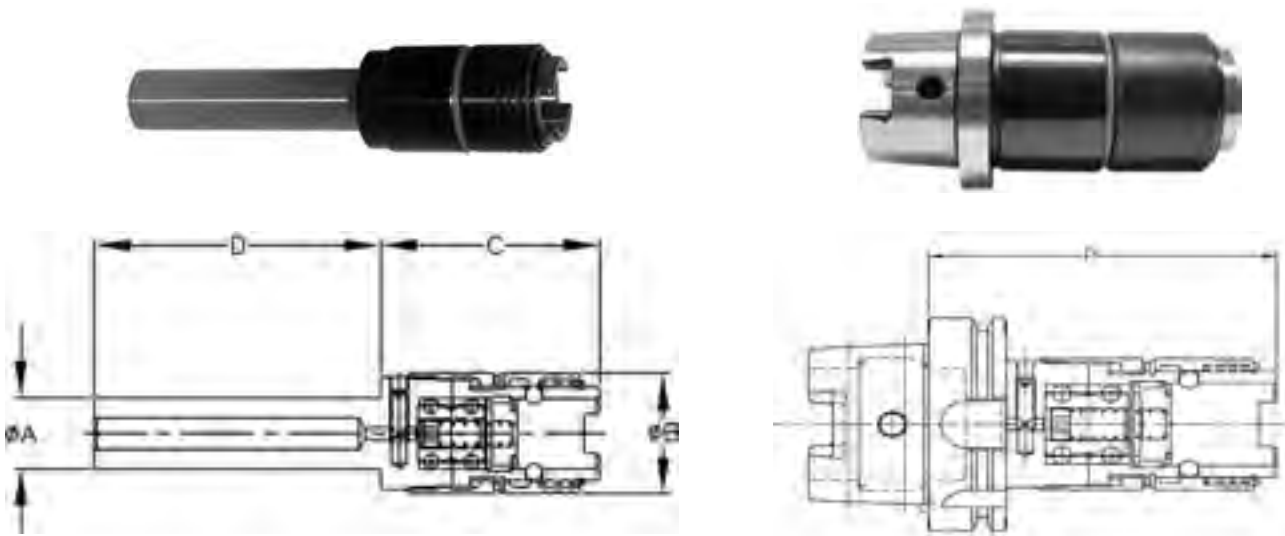

SIZE	PART NUMBER STRAIGHT SHANK	PART NUMBER HSK 'A' SHANK	TAP RANGE	A DIA.	B DIA.	C	D	P HSK	TOTAL FLOAT
0	220-710	220-H32A	SIZE 0 0-1/4 HAND	.6250	.92	1.88	3.00	3.07	.06
0	220-712	220-H40A		.7500			3.00	3.07	
0		220-H50A						3.31	
1	221-712	221-H40A	SIZE 1 0-9/16 HAND	.7500	1.26	2.29	3.00	3.48	.06
1	221-716	221-H50A		1.0000			3.50	3.72	
1	221-720	221-H63A		1.2500			4.00	3.72	
1		221-H80A						3.72	
1		221-H100A						3.84	
2	222-716	222-H63A	SIZE 2 5/16-7/8 HAND	1.0000	1.96	3.37	3.50	4.80	.06
2	222-720	222-H80A		1.2500			4.00	4.80	
2	222-724	222-H100A		1.5000			4.00	4.92	
3	223-732	223-H80A	SIZE 3 3/4-1-3/8 HAND	2.0000	2.83	4.94	5.00	6.37	.09
3	223-740	223-H100A		2.5000			5.00	6.49	

FLOATING HOLDERS



FITH-II Collet Style Floating Tap & Reamer Holder Straight Shank & Acme Shank

Features, Application, Ordering:

- ⇒ Differential Drive Floating System for Smooth True Float
- ⇒ Thru Coolant Design with Back Pressure Flow Control
- ⇒ Adjustable Centering Mechanism, to customize the amount of pressure required to move the tool off center.
- ⇒ Front Side Chip Shield
- ⇒ For use with synchronized feed and spindle rotation.
- ⇒ Order Collets Separately, see page 38.
- ⇒ Specials Available Upon Request.

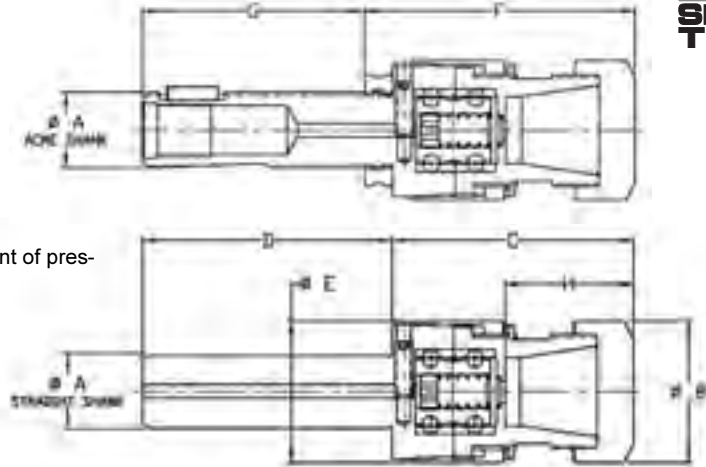

STRAIGHT SHANK PART NUMBER	A DIA	ACME SHANK PART NUMBER	A DIA	COLLET RANGE	B DIA	C	D	E DIA	F	G	H TOOL	TOTAL FLOAT
251-SA11-710	.6250	251-SA11-210	5/8-16	SA11 .019-.275	.63	1.98	3.00	.92	2.39	2.59	.97	.062
251-SA11-712	.7500	251-SA11-212	3/4-12									
253-SA20-712	.7500	253-SA20-212	3/4-12	SA20 .039-.511	1.34	2.78	3.00	1.26	3.19	2.59	1.49	.062
		253-SA20-TR20	TR20-2.0MM									
		253-SA20-214	7/8-12									
253-SA20-716	1.0000											
		253-SA20-217	1 1/16									
		253-SA20-TR28	TR28-1.5MM									
253-SA20-720	1.2500			SA32 .079-.788	1.96	3.59	4.00	1.96	3.91	3.22	1.86	.062
254-SA32-716	1.0000											
		254-SA32-217	1 1/16									
		254SA32-TR28	TR28-1.5MM									
254-SA32-720	1.2500											
		254-SA32-222	1 3/8									
		254SA32-TR36	TR36-2MM	SA40 .125-1.000	2.48	4.14	5.00	2.83	5.22	2.09	.094	
254-SA32-724	1.5000											
243-SA40-728	1.7500								5.34			
		256-SA40-230	1 7/8									

Optional Quick-Change & Collet Style Floating Tap & Reamer Holders Available on Request
With Cat and Bt "V" Shanks

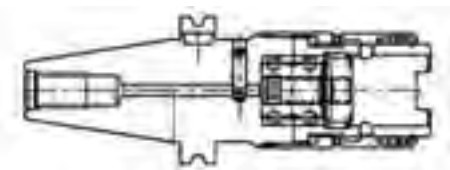

Quick-Change Floating Holder

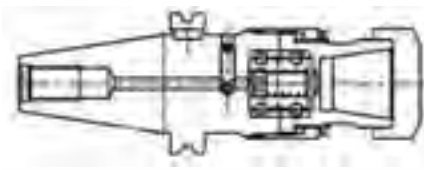

Collet Style Floating Holder

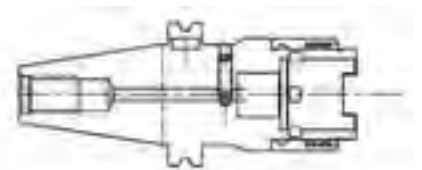

Quick-Change Rigid Holder

TAP HOLDERS



ACTH Adjustable Tension & Compression Quick-Change Tap Holder Acme & Trapezoidal (Metric) Shank



Features, Application, Ordering:

- ⇒ Adjustable Mechanism, allows the customer to customize the amount of tension/compression stroke.
- ⇒ Order Adapters Separately, see page 24.
- ⇒ Optional rust resistant chrome finish, add "ST" to the part number.
- ⇒ Specials Available Upon Request.
- ⇒ Accepts Bilz, Collis, Universal, Lyndex and many other tap adapters.

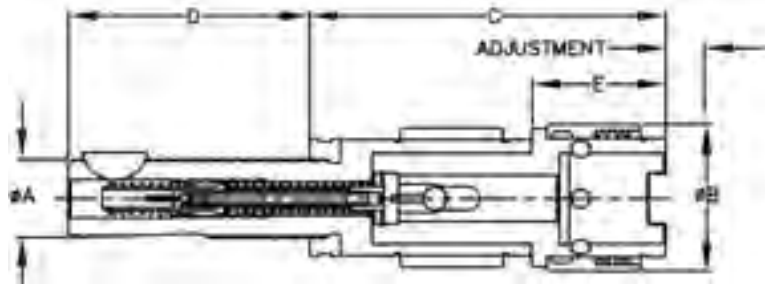

PART NUMBER	TAP RANGE	A ACME	B DIA.	C	D	E	ADJUSTMENT
311-51-217	SIZE 1 0-9/16 HAND	1-1/16-12	1.26	3.21	3.22	1.17	.50
311-51-222		1-3/8-12			4.22		
311-51-TR28*		TR28 X 2.0MM			3.21		
312-52-217	SIZE 2 5/16-7/8 HAND	1-1/16-12	1.96	4.75	3.22	1.79	.88
312-52-222		1-3/8-12			4.22		
312-52-TR28*		TR28 X 2.0MM			3.21		
312-52-TR36*		TR36 X 2.0MM			4.24		
313-53-222	SIZE 3 3/4-1-3/8 HAND	1-3/8-12	2.91	7.00	4.22	2.94	1.38
313-52-TR36*		TR36 X 2.0MM			4.24		

ACTH Adjustable Tension & Compression Quick-Change Tap Holder Straight Shank



Features, Application, Ordering:

- ⇒ Adjustable Mechanism, allows the customer to customize the amount of tension/compression stroke.
- ⇒ Order Adapters Separately, see page 24.
- ⇒ Optional rust resistant chrome finish, add "ST" to the part number.
- ⇒ Specials Available Upon Request.
- ⇒ Accepts Bilz, Collis, Universal, Lyndex and many other tap adapters.

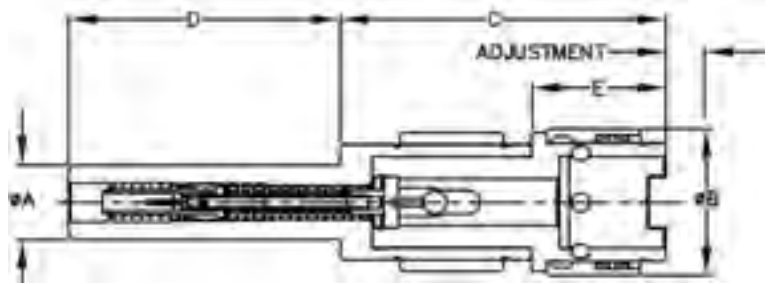

PART NUMBER	TAP RANGE	A DIA.	B DIA.	C	D	E	ADJUSTMENT
311-51-716	SIZE 1 0-9/16 HAND	1.0000	1.26	2.22	4.18	1.17	.50
312-52-716	SIZE 2 5/16-7/8 HAND	1.0000	1.96	4.35	3.62	1.79	.88
312-52-720		1.2500					
313-53-720	SIZE 3 3/4-1-3/8 HAND	1.2500	2.91	6.59	4.60	2.94	1.38
313-53-724*		1.5000					

TAP HOLDERS



LCTH Tension & Compression with FITH-II Float Quick-Change Tap Holder Acme & Trapezoidal (Metric) Shank



Features, Application, Ordering:

- ⇒ Provides FITH-II radial float and full tension, tension & compression or full compression.
- ⇒ Full Tension: Our most popular design. Gives solid start for accurate thread depth and compensation for backlash and lead screw wear.
- ⇒ Available standard in the following configurations, replace the "FT" in the part number below with the designation below:
 - FT: 100% Tension 0% Compression
 - 25C: 75% Tension 25% Compression
 - TNC: 50% Tension 50% Compression
 - 25T: 25% Tension 75% Compression
 - FC: 0% Tension 100% Compression
- ⇒ Order Adapters Separately, see page 24.
- ⇒ Optional rust resistant chrome finish, add "ST" to the part number.
- ⇒ Specials Available Upon Request.
- ⇒ Accepts Bilz, Collis, Universal, Lyndex and many other tap adapters.

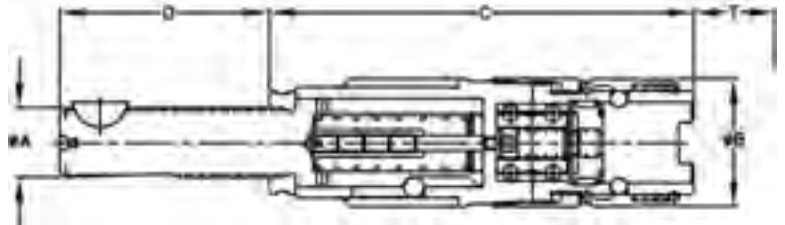

PART NUMBER	TAP RANGE	A SHANK	B DIA.	C	D	T TENSION	T COMPRES-SION	RADIAL FLOAT TIR
321-1-212-FT*	SIZE 1 0-9/16 HAND	3/4-12	1.38	4.28	2.59	.59	0	.07
321-1-217-FT*		1-1/16-12			3.22			
321-1-TR20-FT*		TR20 X 2.0MM			3.06			
321-1-TR28-FT*		TR28 X 2.0MM			3.21			
321-2-212-FT*		3/4-12		4.44	2.59	.79	0	
321-2-217-FT*		1-1/16-12			3.22			
321-3-212-FT*		3/4-12		4.65	2.59	.99	0	
321-3-217-FT*		1-1/16-12			3.22			
321-4-212-FT*		3/4-12		4.84	2.59	1.18	0	
321-4-217-FT*		1-1/16-12			3.22			
321-5-212-FT		3/4-12		5.24	2.59	1.58	0	
321-5-217-FT		1-1/16-12			3.22			
321-5-222-FT		1-3/8-12			4.19			
321-5-TR20-FT*		TR20 X 2.0MM			3.06			
321-5-TR28-FT*	TR28 X 2.0MM	3.21						
322-1-217-FT*	SIZE 2 5/16-7/8 HAND	1-1/16-12	1.97	5.65	3.22	.71	0	.09
322-1-222-FT*		1-3/8-12			4.19			
322-1-TR28-FT*		TR28 X 2.0MM			3.21			
322-1-TR36-FT*		TR36 X 2.0MM			4.24			
322-2-217-FT*		1-1/16-12		5.93	3.22	.99	0	
322-2-222-FT*		1-3/8-12			4.19			
322-3-217-FT*		1-1/16-12		6.12	3.22	1.18	0	
322-3-222-FT*		1-3/8-12			4.19			
322-4-217-FT		1-1/16-12		6.52	3.22	1.58	0	
322-4-222-FT		1-3/8-12			4.19			
322-4-TR28-FT*		TR28 X 2.0MM			3.21			
322-4-TR36-FT*		TR36 X 2.0MM			4.24			
323-3-222-FT	SIZE 3 3/4-1-3/8 HAND	1-3/8-12	2.84	8.77	4.19	1.58	0	.20
323-3-TR36-FT*		TR36 X 2.0MM			4.24			

TAP HOLDERS



LCTH Tension & Compression with FITH-II Float Quick-Change Tap Holder Morse Taper Shank



Features, Application, Ordering:

- ⇒ Provides FITH-II radial float and full tension, tension & compression or full compression.
- ⇒ Full Tension: Our most popular design. Gives solid start for accurate thread depth and compensation for backlash and lead screw wear.
- ⇒ Available standard in the following configurations, replace the "FT" in the part number below with the designation below:
 - FT: 100% Tension 0% Compression
 - 25C: 75% Tension 25% Compression
 - TNC: 50% Tension 50% Compression
 - 25T: 25% Tension 75% Compression
 - FC: 0% Tension 100% Compression
- ⇒ Order Adapters Separately, see page 24.
- ⇒ Optional rust resistant chrome finish, add "ST" to the part number.
- ⇒ Specials Available Upon Request.
- ⇒ Accepts Bilz, Collis, Universal, Lyndex and many other tap adapters.

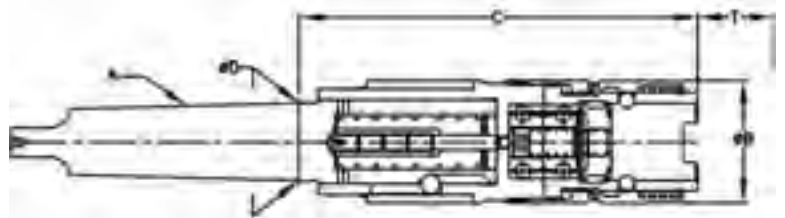

PART NUMBER	TAP RANGE	A SHANK	B DIA.	C	D GAGELINE	T TENSION	T COMPRESSION	RADIAL FLOAT TIR
321-1-302-FT*	SIZE 1 0-9/16 HAND	2 MORSE	1.38	4.16	.700	.59	0	.07
321-1-303-FT*		3 MORSE			.938			
321-2-302-FT*		2 MORSE		4.33	.700	.79	0	
321-2-303-FT*		3 MORSE			.938			
321-3-302-FT*		2 MORSE		4.52	.700	.99	0	
321-3-303-FT*		3 MORSE			.938			
321-4-302-FT*		2 MORSE		4.72	.700	1.18	0	
321-4-303-FT*		3 MORSE			.938			
321-5-302-FT*		2 MORSE		5.11	.700	1.58	0	
321-5-303-FT*		3 MORSE			.938			
322-1-302-FT*	SIZE 2 5/16-7/8 HAND	2 MORSE	1.97	5.53	.700	.71	0	.09
322-1-303-FT*		3 MORSE			.938			
322-2-302-FT*		2 MORSE		5.80	.700	.99	0	
322-2-303-FT*		3 MORSE			.938			
322-3-302-FT*		2 MORSE		6.00	.700	1.18	0	
322-3-303-FT*		3 MORSE			.938			
322-4-302-FT*		2 MORSE		6.39	.700	1.58	0	
322-4-303-FT*		3 MORSE			.938			
323-3-304-FT*	SIZE3 3/4-1-3/8HAND	4 MORSE	2.84	8.67	1.231	1.58	0	.20

TAP HOLDERS



CCTH Close Center Tap Holder with Tension Compensation Acme Shank



Features, Application, Ordering:

- ⇒ Full Tension: Our most popular design. Gives solid start for accurate thread depth and compensation for backlash and lead screw wear.
- ⇒ Optional Solid Design: Omit "T" at the end of the part number when ordering.
- ⇒ For extra length (reach) order tap adapter extension, page 36.
- ⇒ DIN, ISO & JIS Available Upon Request
- ⇒ Specials Available Upon Request.

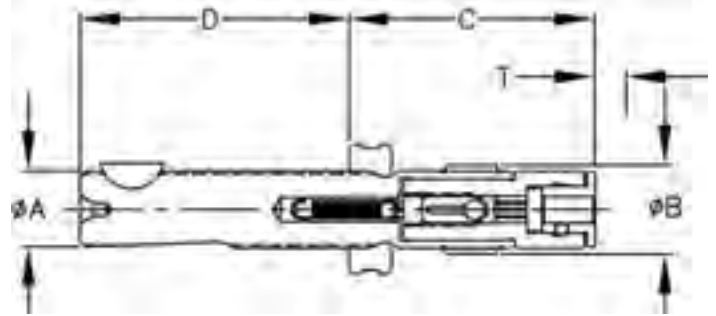

PART NUMBER	TAP RANGE	TAP SHANK	TAP SQUARE	A SHANK	B DIA.	C	T TENSION			
400-106-206T*	#6	.141	.110	3/8-20	.50	2.04	.27			
400-106-208T				1/2-16		2.16				
401-106-208T				1/2-16		2.37				
401-106-210T				#6	.141	.110	5/8-16	.87	2.37	.40
401-106-212T							3/4-12		2.37	
401-106-214T							7/8-12		2.19	
401-106-216T*							1"-12		2.33	
401-106-217T							1-1/16-12		2.33	
400-108-206T*							#8		.168	
400-108-208T	1/2-16	2.19								
401-108-208T	1/2-16	2.37								
401-108-210T	#8	.168	.131	5/8-16	.87	2.37		.40		
401-108-212T				3/4		2.32				
401-108-214T				7/8-12		2.23				
401-108-216T*				1"-12		2.33				
401-108-217T				1-1/16-12		2.33				
400-110-206T*				#10		.194				.152
400-110-208T	1/2-16	2.19								
401-110-208T	1/2-16	2.38								
401-110-210T	#10	.194	.152		5/8-16		.87	2.38	.40	
401-110-212T					3/4-12			2.33		
401-110-214T					7/8-12			2.24		
401-110-216T*					1"-12			2.35		
401-110-217T					1-1/16-12			2.35		
400-112-206T*					#12			.220		
400-112-208T	1/2-16	2.16								
401-112-208T	1/2-16	2.38								
401-112-210T	#12	.220	.165	5/8-16		.87	2.38		.40	
401-112-212T				3/4-12			2.32			
401-112-214T				7/8-12			2.24			
401-112-216T*				1"-12			2.34			
401-112-217T				1-1/16-12			2.34			
400-004-206T*				1/4			.255			.191
400-004-208T	1/2-16	2.17								
401-004-208T	1/2-16	2.37								
401-004-210T	1/4	.255	.191		5/8-16	.87		2.37	.40	
401-004-212T					3/4-12			2.37		
401-004-214T					7/8-12			2.19		
401-004-216T*					1"-12			2.33		
401-004-217T					1-1/16-12			2.33		

Continued on next page...

TAP HOLDERS



CCTH Close Center Tap Holder Continued

PART NUMBER	TAP RANGE	TAP SHANK	TAP SQUARE	A SHANK	B DIA.	C	T TENSION
401-005-208T	5/16	.318	.238	1/2-16	.87	2.36	.40
401-005-210T				5/8-16		2.36	
401-005-212T				3/4-12		2.36	
401-005-214T				7/8-12		2.18	
401-005-216T*				1"-12		2.32	
401-005-217T				1-1/16-12		2.32	
401-006-208T	3/8	.381	.286	1/2-16	.87	2.37	.40
401-006-210T				5/8-16		2.37	
401-006-212T				3/4-12		2.37	
401-006-214T				7/8-12		2.19	
401-006-216T*				1"-12		2.33	
401-006-217T				1-1/16-12		2.32	
401-007-210T	7/16	.323	.242	5/8-16	.87	2.37	.40
401-007-212T				3/4-12		2.37	
401-007-214T				7/8-12		2.19	
401-007-216T*				1"-12		2.33	
401-007-217T				1-1/16-12		2.33	
401-008-210T	1/2	.367	.275	5/8-16	.87	2.35	.40
401-008-212T				3/4-12		2.35	
401-008-214T				7/8-12		2.35	
401-008-216T*				1"-12		2.31	
401-008-217T				1-1/16-12		2.31	
401-009-210T	9/16	.429	.322	5/8-16	.87	2.38	.40
401-009-212T				3/4-12		2.38	
401-009-214T				7/8-12		2.20	
401-009-216T*				1"-12		2.35	
401-009-217T				1-1/16-12		2.35	
402-009-217T				1-1/16-12		1.18	
402-009-222T	1-3/8-12	3.45					
402-010-217T	5/8	.480	.360	1-1/16-12	1.18	3.70	.60
402-010-222T				1-3/8-12		3.51	
402-011-217T	11/16	.542	.406	1-1/16-12	1.18	3.70	.60
402-011-222T				1-3/8-12		3.52	
402-012-217T	3/4	.590	.442	1-1/16-12	1.18	3.70	.60
402-012-222T				1-3/8-12		3.52	
402-013-217T	13/16	.652	.489	1-1/16-12	1.18	3.70	.60
402-013-222T				1-3/8-12		3.51	
402-014-217T	7/8	.697	.523	1-1/16-12	1.18	3.69	.60
402-014-222T				1-3/8-12		3.50	
401-202-210T	1/8 NPT	.438	.328	5/8-16	.87	2.37	.40
401-202-212T				3/4-12		2.37	
401-202-214T				7/8-12		2.19	
401-202-216T*				1"-12		2.34	
401-202-217T				1-1/16-12		2.39	
402-202-217T				1-1/16-12		1.18	
402-202-222T	1-3/8-12	3.44					
402-204-217T	1/4 NPT	.563	.421	1-1/16-12	1.18	3.66	.60
402-204-222T				1-3/8-12		3.47	
402-206-217T	3/8 NPT	.700	.531	1-1/16-12	1.18	3.66	.60
402-206-222T				1-3/8-12		3.47	
402-208-217T	1/2 NPT	.688	.515	1-1/16-12	1.18	3.66	.60
402-208-222T				1-3/8-12		3.47	

TAP HOLDERS



SITH Quick-Change Rigid Tap & Reamer Holder Acme Shank



Features, Application, Ordering:

- ⇒ Thru Coolant Design
- ⇒ For use with machines with synchronized feed and spindle rotation.
- ⇒ Order Adapters Separately, see page 24.
- ⇒ Spindle coolant inducers available, see page 69.
- ⇒ Optional rust resistant chrome finish, add "ST" to the part number.
- ⇒ Specials Available Upon Request.
- ⇒ Accepts Bilz, Collis, Universal, Lyndex and many other tap adapters.

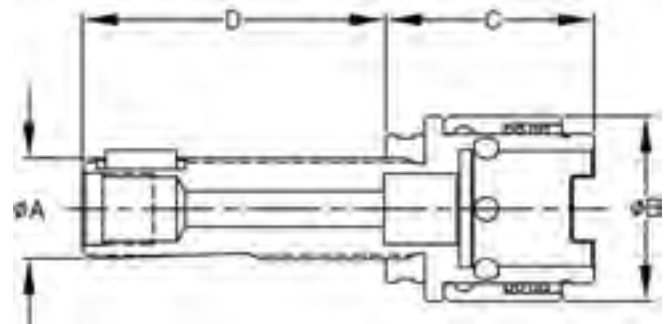

PART NUMBER	TAP RANGE	A ACME	B DIA.	C	D	REF. COOLANT INDUCER
121-212C	SIZE 1	3/4-12	1.26	1.57	2.59	331-4014-20
121-217C*	0-9/16 HAND	1-1/16-12			3.22	332-4016-18
122-217C	SIZE 2	1-1/16-12	1.96	2.20	3.22	332-4016-18
122-222C	5/16-7/8 HAND	1-3/8-12			4.22	332-4020-18

FLOATING HOLDERS



SQUARE DRIVE PRESET SCREWS For Reamer and Tap shanks

- ⇒ Threads into the socket of the floating holder or collet chuck. NOTE: Loctite threads in heavy applications.
- ⇒ Other styles and sizes available upon request.

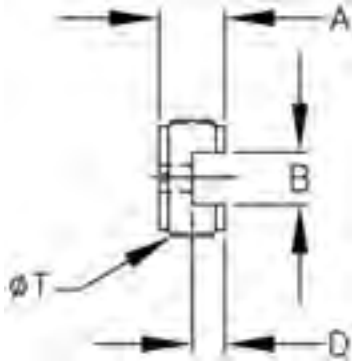

PART NUMBER	COLLET SERIES	T THREAD	A SCREW LENGTH	S MAX. TANG	B MIN. TANG
PS07C-094	SA16	7/16-20 LH	.38	.094	.10
PS07C-122				.122	.10
PS07C-162				.162	.10
PS07C-191				.191	.10
PS07C-203				.203	.18
PS07C-243				.242	.18
PS07C-280				.280	.18
PS08C-094*	SA20	1/2-20 LH	.50	.094	.10
PS08C-122*				.122	.10
PS08C-162*				.162	.10
PS08C-203*				.203	.18
PS08C-243*				.243	.18
PS14C-162	SA32	7/8-14 LH	.50	.162	.18
PS14C-203				.203	.18
PS14C-243				.243	.18
PS14C-303				.303	.20
PS14C-373				.373	.20
PS14C-406				.406	.20
PS14C-443				.443	.25
PS14C-524	.524	.25			
PS18C-203*	SA40	1 1/8-16 LH	.94	.203	.18
PS18C-243*				.243	.18
PS18C-303*				.303	.20
PS18C-373*				.373	.20
PS18C-443*				.443	.31
PS18C-514*				.514	.50
PS18C-609*	.609	.62			
PS26C-303*	SG15	1 5/8-12 LH	1.00	.303	.20
PS26C-373*				.373	.20
PS26C-443*				.443	.31
PS26C-514*				.514	.50
PS26C-609*				.609	.62
PS26C-817*				.817	.69

TAP ADAPTERS for Coolant Thru DIN 371 & 376 Taps



CSTA- Collet Style Sealed Tap Adapters Length Adjustable, Positive Drive

Features, Application, Ordering

- ⇒ Adjustment; 51-Series +/- 1MM , 52-Series +/- 2MM
- ⇒ Order Collets Separately—For Coolant applications a sealed collet or coolant disk nut is required.
- ⇒ ISO & JIS Available Upon Request
- ⇒ Specials Available Upon Request.
- ⇒ 3 MM & 4MM Taps Thru Coolant Spec Order Only
- ⇒ To Protect Seals Coolant Must Not Deadhead Into Tool Holder System

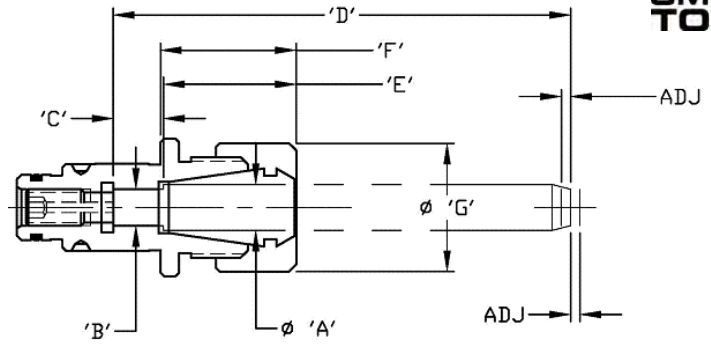

TAP SIZE MM	TAP ADAPTER NUMBER	COLLET	ADJUSTMENT SCREW	A MM DIA SHANK	B MM SQ. WIDTH	C MM SQ. LENGTH	D MM OAL	E 'A' SHANK ENTRY	F NUT TO FLANGE	G NUT DIA
3	51-SA16-106SC	SA-16-40	PS03C-N106	3.5	2.7	6	56	29.0	29.6	28.0
4	51-SA16-134SC	SA-16-40	PS03C-N134	4.5	3.4	6	63			
5	51-SA16-193SC	SA-16-60	PS03C-N193	6	4.9	8	70			
6	51-SA16-193SC	SA-16-60	PS03C-N193	6	4.9	8	80			
8	51-SA16-244SC	SA-16-80	PS03C-N193	8	6.2	9	90			
9	51-SA16-276SC	SA-16-80	PS03C-N193	8	7	9	90			
10	51-SA16-315SC	SA-16-100	PS05CN315	10	8	11	100			
11	51-SA16-315SC	SA-16-100	PS05CN315	10	8	11	100			
12	51-SA16-276SC	SA-16-100	PS03C-N193	9	7	10	110			
14	52-SA32-354SC	SA-32-110	PS07CN354	11	9	12	110			
16	52-SA32-354SC	SA-32-120	PS07CN354	12	9	12	110			
18	52-SA32-433SC	SA-32-140	PS07CN354	14	11	14	125			
20	52-SA32-472SC	SA-32-160	PS07CN354	16	12	15	140			
22	52-SA32-570SC	SA-32-180	PS07CN354	18	14.5	17	140			
24	52-SA32-570SC	SA-32-180	PS07CN354	18	14.5	17	160			
27	52-SA32-630SC	SA-32-200	PS07CN354	20	16	19	160			

FITH-II Sealed Quick-Chg Floating Holders For Sealed CSTA Tap Adapters

⇒ All Common and Custom Shanks Available Upon Request

PART NUMBER	TAP RANGE	A ACME	B DIA.	C	D
221-210SC	SIZE 1 0-9/16 HAND	5/8-16	1.26	3.10	2.59
221-212SC		3/4-12			2.59
221-214SC		7/8-12			3.22
221-217SC		1-1/16-12			3.22
221-TR20SC		TR20 X 2.0MM			3.06
221-TR28SC		TR28 X 2.0MM			3.21
222-217SC	SIZE 2 5/16-7/8 HAND	1-1/16-12	1.96	4.40	3.22
222-222SC		1-3/8-12			4.22
222-TR28SC		TR28 X 2.0MM			3.21
222-TR36SC	TR36 X 2.0MM	4.24			
223-222SC	SIZE 3 3/4-1-3/8 HAND	1-3/8-12	2.83	6.00	4.22
223-230SC		1-7/8-12			5.22
223-TR36SC		TR36 X 2.0MM			4.24

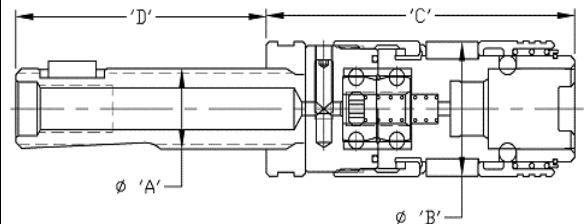

TAP ADAPTERS



T.M. Smith offers the widest assortment of Quick-Change Tap adapters in the market today. T.M. Smith Tool pioneered the Ball Drive tap adapter in 1970 and today the design still provides the highest torque available in a direct drive adapter. Even our “tang drive” competition in high torque applications recommends a ball style drive.

Why ball drive? Ball drive transfers the torque of the application down into the holder instead of the face of the holder allowing for longer tool life with less radial slop. This is ideal for synchronized, rigid, and control depth tapping. Couple this with a full tension tool holder to compensate for miss-feed and backlash and you have the most effective tapping solution on the market today.

PRODUCTS IN THIS SECTION:

- ⇒ NTA—Direct Drive Tap Adapters
- ⇒ NTLA—Length Adjustable Direct Drive
- ⇒ NTER—Extended Range Direct Drive
- ⇒ CSTA—Collet Style Direct Drive
- ⇒ TA—Torque Control Tap Adapters

SPECIAL DESIGNS AVAILABLE TO SUIT YOUR APPLICATION!

- ⇒ Contact our engineering department with your specifications, samples or drawings. We have over 120 years combined manufacturing and engineering experience to serve you. You can email us at engineering@tmsmith.com or visit our web site at <http://www.tmsmith.com>.

ERROR PROOFING

- ⇒ Tap Adapters are available with special error proofing options to suit your specific application.



TECHNICAL INFORMATION



Tap Adapter Shank and Square Sizes

To determine which tap adapter to select for the tap you are using:

1. Measure the tap shank and square sizes.
2. Match the sizes for the shank and square with those on the left side of the chart.
3. Once matched go to the left side of the chart for the part number.

⇒ Please contact Customer Service with any questions or problems.

T.M. Smith NTA Part Number	Shank Diameter		Square Size		Tap Size														
	MM	Inch	MM	Inch	ANSI		ISO Full	ISO Rel	ISO Full	ISO Rel	JIS	DIN 352	DIN 353	DIN 371	DIN 374	DIN 376	DIN 2182	DIN 2183	
					Inch	Metric	UNC/UNF		BSW										
	2.24	0.088	1.8	0.071				M3 & #5											
	2.5	0.098	2.0	0.079			M1 & M2	M3.5 & #6											
	2.5	0.098	2.1	0.083							M1 & M1.8			M1 & M1.8	M3.5	M3.5	1/16"		
51-50280	2.8	0.110	2.1	0.083							M2 & M2.6			M2 & M2.6	M4	M4	3/32"	5/32"	
	2.8	0.110	2.24	0.088			M2 & M2.5												
51-60300	3.0	0.118	2.5	0.098						M1 & M2.6									
	3.15	0.124	2.5	0.098			M3 #4 & #5	M4 & #8											
51-50350	3.5	0.138	2.7	0.106							M3			M3	M4.5 & M5	M4.5 & M5	1/8"		
51-40355	3.55	0.140	2.8	0.110			M3.5 & #6	M4.5 & #10	3/16"										
50-106 51-106		0.141		0.110	#0 THRU #6	M1.6													
51-50400	4.0	0.157	3.0	0.118							M3.5			M3.5			7/32"		
51-40400	4.0	0.157	3.15	0.124			M4	M5, M5.5 & #12											
51-60400	4.0	0.157	3.20	0.126						M3 & M3.5									
50-108 51-108		0.168		0.131	#8	M4													
51-50450	4.5	0.177	3.4	0.134							M4			M4	M6	M6	5/32"	1/4"	
51-40450	4.5	0.177	3.55	0.140			M4.5 & #8	M6 & 1/4	1/4"										
50-110 51-110		0.194		0.152	#10	M4.5 & M5													
51-40500	5.0	0.197	4.0	0.157			M5 & #10		3/16"	M4 & M4.5									
	5.5	0.217	4.3	0.169										M7	M7				
51-60550	5.5	0.217	4.5	0.177						M5 & M5.5									
51-112		0.220		0.165	#12														
51-40560	5.6	0.220	4.5	0.177			M5.5 & #12	M7											
51-60600	6.0	0.236	4.5	0.177						M6 & 1/4									
51-50600	6.0	0.236	4.9	0.193							M4.5, M5 & M6			M5 & M6	M8	M8			
	6.1	0.240	5.0	0.197						5/16"									
51-60620	6.2	0.244	5.0	0.197						M7 & M8									
51-40630	6.3	0.248	5.0	0.197			M6 & 1/4	M8 & 5/16	1/4"	5/16"									
50-004 51-004		0.255		0.191	#14 & 1/4	M6 & M6.3													
51-50700	7.0	0.276	5.5	0.217						M9 & M10 & 3/8	M7	1/8"		M9 & M10	M9 & M10	1/4"	3/8"		
51-40710	7.1	0.280	5.6	0.220			M7	M9 & 3/8	3/8"										
51-005		0.313		0.234	1/8"ssP & 1/16P														
51-60800	8.0	0.315	6.0	0.236						M11, 7/16 & 1/8P									
51-50800	8.0	0.315	6.2	0.244										M8	M11	M11	5/16"	7/16"	
51-40800	8.0	0.315	6.3	0.248			M8 & 5/16	M10, M11 & 7/16	5/16"	7/16"									
51-005		0.318		0.238	5/16"	M7 & 8													
51-007		0.323		0.242	7/16"														
51-60850	8.5	0.335	6.5	0.256						M12									
51-50900	9.0	0.354	7.0	0.276						1/2"	M12			M9	M12	M12	3/8"	1/2"	
51-40900	9.0	0.354	7.1	0.280			M9	M12 & 1/2	1/2"										
51-008		0.367		0.275	1/2"	M12 & M12.5													
	9.5	0.374	7.0	0.276						M13									
51-006		0.381		0.286	3/8"	M10													
51-41000	10.0	0.394	8.0	0.315			M10 & 3/8		3/8"					M10					
52-61050	10.5	0.413	8.0	0.315						M14, M15 & 9/16									
51-009		0.429		0.322	9/16"	M14													
52-51100	11.0	0.433	9.0	0.354						1/4" P	M14	1/4"		M14	M14		9/16"		
51-202		0.438		0.328	1/8" P														

TECHNICAL INFORMATION



Continued from previous page

T.M. Smith NTA Part Number	Tap Size																
	Shank Diameter		Square Size		ANSI	ANSI	ISO	ISO									
	MM	Inch	MM	Inch	Inch	Metric	UNC/UNF	BSW	JIS	DIN 352	DIN 353	DIN 371	DIN 374	DIN 376	DIN 2182	DIN 2183	
52-41120	11.2	0.441	9.0	0.354			M14, M15 & 9/16	9/16									
52-51200	12.0	0.472	9.0	0.354				5/8	M16	3/8		M16	M16				5/8
52-010		0.480		0.360	5/8	M16											
52-41250	12.5	0.492	10.0	0.394			M16, M17 & 5/8	5/8	M16								
	13.0	0.512	10.0	0.394					M17								
52-011		0.542		0.406	11/16	M18											
52-51400	14.0	0.551	11.0	0.433					M18, 3/4 & 3/8 PIPE	M18			M18	M18			11/16
52-41400	14.0	0.551	11.2	0.441			M18, M20 & 3/4	11/16 & 3/4									
52-204		0.563		0.421	1/4 P												
52-012		0.590		0.442	3/4												
52-61500	15.0	0.591	12.0	0.472					M20								
52-51600	16.0	0.630	12.0	0.472						M20	1/2		M20	M20			13/16
52-41600	16.0	0.630	12.5	0.492			M22 & 7/8	7/8									
52-013		0.652		0.489	13/16	M20											
52-61700	17.0	0.669	13.0	0.512					M22 & 7/8								
52-208		0.688		0.515	1/2 P												
52-014		0.697		0.523	7/8	M22											
52-206		0.700		0.531	3/8 P												
52-41800	18.0	0.709	14.0	0.551			M24, M25 & 1	1	1/2 P								
52-51800	18.0	0.709	14.5	0.571						M22 & M24	5/8		M22 & M24	M22 & M24			7/8 & 15/16
53-61900	19.0	0.748	15.0	0.591					M24, M25 & 5/8 PIPE								
53-015		0.760		0.570	15/16	M24											
53-62000	20.0	0.787	15.0	0.591					M26, M27 & 1								
53-42000	20.0	0.787	16.0	0.630			M27, M28, M30 & 1-1/8	1-1/8		M27	3/4		M27	M27			1
53-016		0.800		0.600	1	M25											
	21.0	0.827	17.0	0.669					M28								
53-62200	22.0	0.866	17.0	0.669					1-1/8								
53-52200	22.0	0.866	18.0	0.709						M30	7/8		M30	M30			1-1/8
53-42240	22.4	0.882	18.0	0.709			M32, M33 & 1-1/4	1-1/4									
53-018		0.896		0.672	1-1/16, 1-1/8	M27											
53-62300	23.0	0.906	17.0	0.669					M30								
53-212		0.906		0.679	3/4 P												
	24.0	0.945	19.0	0.748					M32								
	25.0	0.984	19.0	0.748					M33								
53-42500	25.0	0.984	20.0	0.787			M35, M36 & 1-3/8			M33			M33	M33			1-1/4
53-020		1.021		0.766	1-1/4	M30											
	26.0	1.024	21.0	0.827					M34 & M35								
	28.0	1.102	21.0	0.827					M36 & M38								
	28.0	1.102	22.0	0.866						M36			M36	M36			1-3/8
	28.0	1.102	22.4	0.882			M39, M40, M42, 1-1/2 & 1-5/8										
53-022		1.108		0.831	1-5/16, 1-3/8	M33											
53-216		1.125		0.843	1 P												

TAP ADAPTERS



NTA-ANSI

Direct Drive Tap Adapter Coolant Thru

- ⇒ Compatible with Bilz, Collis, Universal, Lyndex and many other tap holders.
- ⇒ Coolant Thru—Note: Due to the fit between Tap Shanks and the adapter, some leakage may occur.
- ⇒ DIN, ISO & JIS Available Upon Request.
- ⇒ Specials Available Upon Request.
- ⇒ For Carbide Taps use collet style on page 33.

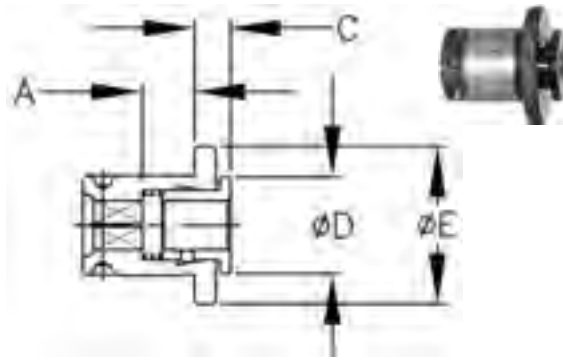

PART NUMBER	ADAPTER SIZE	TAP SIZE	SHANK DIA	SHANK DIA MM	SQUARE	SQUARE MM	A	C	D	E
50-106	0	0-6	0.141	3.58	0.11	2.79	0.32	0.29	0.49	0.86
50-108		8	0.168	4.27	0.13	3.33				
50-110		10	0.194	4.93	0.15	3.86				
50-112*		12	0.220	5.59	0.17	4.19				
50-004		1/4	0.255	6.48	0.19	4.85				
51-106	1	0-6	0.141	3.58	0.11	2.79	0.31	0.27	0.73	1.18
51-108		8	0.168	4.27	0.13	3.33	0.31			
51-110		10	0.194	4.93	0.15	3.86	0.39			
51-112		12	0.220	5.59	0.17	4.19	0.31			
51-004		1/4	0.255	6.48	0.19	4.85	0.39			
51-005		5/16	0.318	8.08	0.24	6.05				
51-006		3/8	0.381	9.68	0.29	7.26				
51-007		7/16	0.323	8.20	0.24	6.15				
51-008		1/2	0.367	9.32	0.28	6.99				
51-009		9/16	0.429	10.90	0.32	8.18	0.31			
51-202		1/8 RS PIPE	0.438	11.13	0.33	8.33	0.39	0.27		
52-005		5/16	0.318	8.08	0.24	6.05	0.35			
52-006		3/8	0.381	9.68	0.29	7.26				
52-007		7/16	0.323	8.20	0.24	6.15				
52-008		1/2	0.367	9.32	0.28	6.99				
52-009	9/16	0.429	10.90	0.32	8.18	0.30				
52-010	2	5/8	0.480	12.19	0.36	9.14	0.70	0.40	1.17	1.88
52-011		11/16	0.542	13.77	0.41	10.31				
52-012		3/4	0.590	14.99	0.44	11.23				
52-013		13/16	0.652	16.56	0.49	12.42				
52-014		7/8	0.697	17.70	0.52	13.28	0.69			
52-202		1/8 RS PIPE	0.438	11.13	0.33	8.33		0.35		
52-204		1/4 PIPE	0.563	14.30	0.42	10.69		0.40		
52-206		3/8 PIPE	0.700	17.78	0.53	13.49				
52-208	1/2 PIPE	0.688	17.48	0.52	13.08					
53-012	3	3/4	0.590	14.99	0.44	11.23	0.66		0.41	1.17
53-013*		13/16	0.652	16.56	0.49	12.42	0.69			
53-014*		7/8	0.697	17.70	0.52	13.28	0.71			
53-015		15/16	0.760	19.30	0.57	14.48	1.07	0.60	1.87	
53-016		1	0.800	20.32	0.60	15.24				
53-018		1 1/16 & 1 1/8	0.896	22.76	0.67	17.07				
53-020		1 3/16 & 1 1/4	1.021	25.93	0.77	19.46				
53-022		1 5/16 & 1 3/8	1.108	28.14	0.83	21.11				
53-212		3/4 PIPE	0.906	23.01	0.68	17.25	0.36	0.38	1.89	
53-216		1" PIPE	1.125	28.58	0.84	21.41				

TAP ADAPTERS



NTA-TD-ANSI Tang Drive Direct Drive Tap Adapter Coolant Thru

Features, Application, Ordering:

- ⇒ Compatible with Bilz, Collis, Universal, Lyndex and many other tap holders.
- ⇒ Coolant Thru—Note: Due to the fit between Tap Shanks and the adapter, some leakage may occur.
- ⇒ DIN, ISO & JIS Available Upon Request.
- ⇒ For Carbide Taps use collet style on page 33.

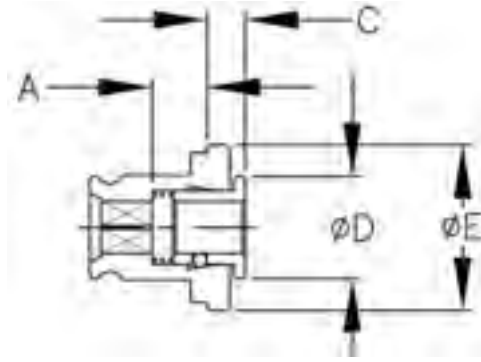

PART NUMBER	ADAPTER SIZE	TAP SIZE	SHANK DIA	SHANK DIA MM	SQUARE	SQUARE MM	A	C	D	E	
51-106TD	1	0-6	0.141	3.58	0.11	2.79	0.31	0.37	0.73	1.18	
51-108TD		8	0.168	4.27	0.13	3.33	0.31				
51-110TD		10	0.194	4.93	0.15	3.86	0.39				
51-112TD		12	0.220	5.59	0.17	4.19	0.31				
51-004TD		1/4	0.255	6.48	0.19	4.85	0.39	0.38			
51-005TD		5/16	0.318	8.08	0.24	6.05					
51-006TD		3/8	0.381	9.68	0.29	7.26					
51-007TD		7/16	0.323	8.20	0.24	6.15					
51-008TD		1/2	0.367	9.32	0.28	6.99	0.31				
51-009TD		9/16	0.429	10.90	0.32	8.18	0.39				
51-202TD		1/8 RS PIPE	0.438	11.13	0.33	8.33	0.39				
52-005TD		2	5/16	0.318	8.08	0.24	6.05	0.35			0.42
52-006TD	3/8		0.381	9.68	0.29	7.26					
52-007TD	7/16		0.323	8.20	0.24	6.15					
52-008TD	1/2		0.367	9.32	0.28	6.99					
52-009TD	9/16		0.429	10.90	0.32	8.18	0.30				
52-010TD	5/8		0.480	12.19	0.36	9.14	0.70	0.46			
52-011TD	11/16		0.542	13.77	0.41	10.31					
52-012TD	3/4		0.590	14.99	0.44	11.23					
52-013TD	13/16		0.652	16.56	0.49	12.42					
52-014TD	7/8		0.697	17.70	0.52	13.28	0.62				
52-202TD	1/8 RS PIPE		0.438	11.13	0.33	8.33	0.35	0.38	0.73		
52-204TD	1/4 PIPE		0.563	14.30	0.42	10.69	0.40	0.39	1.17		
52-206TD	3/8 PIPE		0.700	17.78	0.53	13.49					
52-208TD	1/2 PIPE		0.688	17.48	0.52	13.08					
53-012TD	3/4		0.590	14.99	0.44	11.23				0.66	
53-013TD	13/16		0.652	16.56	0.49	12.42	0.69	0.50	1.17		
53-014TD	7/8	0.697	17.70	0.52	13.28	0.71					
53-015TD	15/16	0.760	19.30	0.57	14.48						
53-016TD	1	0.800	20.32	0.60	15.24	1.07	0.71	1.87			
53-018TD	1 1/16 & 1 1/8	0.896	22.76	0.67	17.07						
53-020TD	1 3/16 & 1 1/4	1.021	25.93	0.77	19.46						
53-022TD	1 5/16 & 1 3/8	1.108	28.14	0.83	21.11						
53-212TD	3/4 PIPE	0.906	23.01	0.68	17.25	0.36	0.46	1.89			
53-216TD	1" PIPE	1.125	28.58	0.84	21.41						

TAP ADAPTERS



NTA-ISO 529 / 2283 METRIC Direct Drive Tap Adapter Coolant Thru

- Features, Application, Ordering:**
- ⇒ Compatible with Bilz, Collis, Universal, Lyndex and many other tap holders.
 - ⇒ Coolant Thru—Note: Due to the fit between Tap Shanks and the adapter, some leakage may occur.
 - ⇒ ANSI, DIN & JIS Available Upon Request.
 - ⇒ Specials Available Upon Request.
 - ⇒ For Carbide Taps use collet style on page 33.

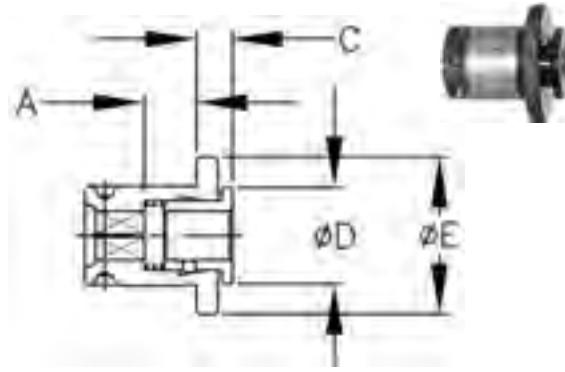

PART NUMBER	ADAPTER SIZE	SHANK DIA	SHANK DIA MM	SQUARE	SQUARE MM	A	C	D	E
51-40355*	1	.138	3.5	.110	2.8	0.39	0.29	1.18	0.73
51-40400*		.157	4.0	.122	3.1				
51-40450*		.177	4.5	.138	3.5				
51-40500*		.197	5.0	.157	4.0				
51-40560*		.220	5.6	.177	4.5				
51-40630*		.248	6.3	.197	5.0				
51-40710*		.276	7.0	.220	5.6				
51-40800*		.315	8.0	.248	6.3				
51-40900*		.354	9.0	.280	7.1				
51-41000*		.394	10.0	.315	8.0				
52-40800*		2	.315	8.0	.248				
52-40900*	.354		9.0	.280	7.1				
52-41000*	.394		10.0	.315	8.0				
52-41120*	.441		11.2	.354	9.0				
52-41250*	.492		12.5	.394	10.0				
52-41400*	.551		14.0	.441	11.2				
52-41600*	.630		16.0	.492	12.5				
53-41800*	3	.709	18.0	.551	14.0	0.71	0.38	2.75	1.17
53-42000*		.787	20.0	.630	16.0				
53-42240*		.882	22.4	.709	18.0				
53-42500*		.984	25.0	.787	20.0				

TAP ADAPTERS



NTA-DIN 371-376 METRIC Direct Drive Tap Adapter Coolant Thru

- Features, Application, Ordering:**
- ⇒ Compatible with Bilz, Collis, Universal, Lyndex and many other tap holders.
 - ⇒ Coolant Thru—Note: Due to the fit between Tap Shanks and the adapter, some leakage may occur.
 - ⇒ ANSI, ISO & JIS Available Upon Request.
 - ⇒ Specials Available Upon Request.
 - ⇒ For Carbide Taps use collet style on page 33.

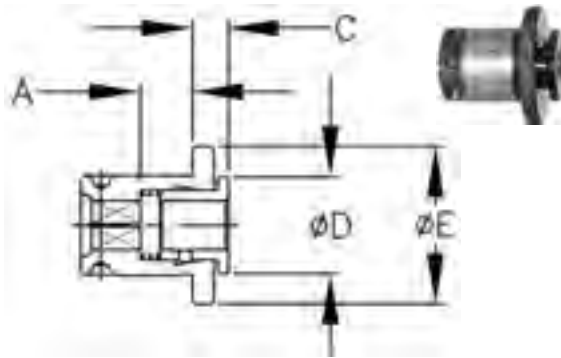

PART NUMBER	ADAPTER SIZE	SHANK DIA	SHANK DIA MM	SQUARE	SQUARE MM	A	C	D	E
51-50350	1	.138	3.5	.106	2.7	0.39	0.29	0.73	1.18
51-50400		.157	4.0	.118	3.0				
51-50450		.177	4.5	.134	3.4				
51-50600		.236	6.0	.193	4.9				
51-50700		.276	7.0	.217	5.5				
51-50800		.315	8.0	.244	6.2				
51-50900		.354	9.0	.276	7.0				
51-41000		.394	10.0	.315	8.0				
52-50600	2	.236	6.0	.193	4.9	0.35	0.29	0.73	1.88
52-50700		.276	7.0	.217	5.5				
52-50800		.315	8.0	.244	6.2				
52-50900		.354	9.0	.276	7.0				
52-41000		.394	10.0	.315	8.0				
52-51100		.433	11.0	.354	9.0				
52-51200		.472	12.0	.354	9.0				
52-51400		.551	14.0	.433	11.0				
52-51600		.630	16.0	.472	12.0				
52-51800		.709	18.0	.571	14.5				
53-51800#	3	.709	18.0	.571	14.5	0.71	0.38	1.17	2.75
53-42000#		.787	20.0	.630	16.0				
53-52200#		.866	22.0	.709	18.0				
53-42500#		.984	25.0	.787	20.0				

TAP ADAPTERS



ENTER-ANSI Direct Drive Tap Adapter Coolant Thru Extended Range



Features, Application, Ordering:

- ⇒ Compatible with Bilz, Collis, Universal, Lyndex and many other tap holders.
- ⇒ Coolant Thru—Note: Due to the fit between Tap Shanks and the adapter, some leakage may occur.
- ⇒ **LIGHT DUTY USE ONLY!** - Adapter exceeds the recommend tap range of some tap drivers.
- ⇒ Specials Available Upon Request.
- ⇒ For Carbide Taps use collet style on page 33.

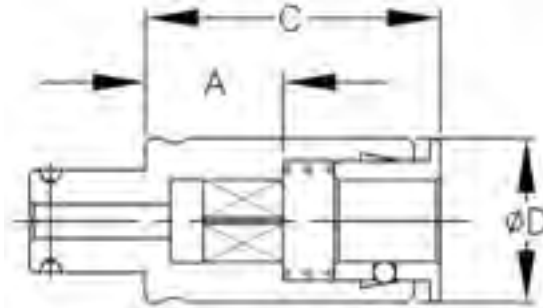

ORDER NUMBER	ADAPTOR SIZE	TAP SIZE ANSI	SHANK DIA	SHANK DIA MM	SQUARE	SQUARE MM	A	C	D
51-010	1	5/8	.480	12.19	.360	9.14	.99	2.19	1.18
51-011*		11/16	.542	13.77	.406	10.31			
51-012*		3/4	.590	14.99	.442	11.23			
51-013*		13/16	.652	16.56	.489	12.42			
51-014*		7/8	.697	17.70	.523	13.28	.63	1.45	
51-2040		1/4 PIPE	.563	14.30	.421	10.69			
51-2060		3/8 PIPE	.700	17.78	.531	13.49			
51-2080		1/2 PIPE	.688	17.48	.515	13.08	.82		
52-015*	2	15/16	.760	19.30	.570	14.48	1.35	3.01	1.88
52-016		1	.800	20.32	.600	15.24			
52-018		1-1/16 & 1-1/8	.896	22.76	.672	17.07			
52-020*		1-3/16 & A-1/4	1.021	25.93	.766	19.46			
52-022*		1-5/16 & 1-3/8	1.108	28.14	.831	21.11	1.00	1.78	
52-2120		3/4 PIPE	.906	23.01	.679	17.25			
52-2160		1 PIPE	1.125	28.58	.843	21.41	1.08		
53-024*	3 Not Shown Set Screw Construction	1-7/16 & 1-1/2	1.233	31.32	.925	23.50	1.90	2.90	2.75
53-026*		1-5/8	1.305	33.15	.979	24.87			
53-028*		1-3/4	1.430	36.32	1.072	27.23			
53-030*		1-7/8	1.519	38.58	1.139	28.93			
53-032*		2	1.644	41.76	1.233	31.32			
53-034*		2-1/8	1.769	44.93	1.327	33.71			
53-036*		2-1/4	1.894	48.11	1.420	36.07			
53-038*		2-3/8	2.019	51.28	1.514	38.46			
53-040*		2-1/2	2.100	53.34	1.575	40.01			
53-2200*		1-1/4 PIPE	1.313	33.35	.984	24.99			
53-2240*		1-1/2 PIPE	1.500	38.10	1.125	28.58	1.25	1.65	
53-2320*		2 PIPE	1.875	47.63	1.406	35.71	1.38	2.90	

TAP ADAPTERS



TA-TD-ANSI TANG DRIVE Torque Control Tap Adapter Coolant Thru

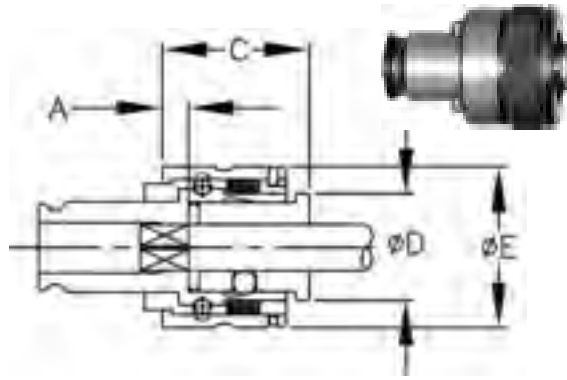

Features, Application, Ordering:

- ⇒ Compatible with Bilz, Collis, Universal, Lyndex and many other tap holders.
- ⇒ Coolant Thru—Note: Due to the fit between Tap Shanks and the adapter, some leakage may occur.
- ⇒ ANSI, ISO & JIS Available Upon Request.
- ⇒ Specials Available Upon Request.

PART NUMBER	ADAPTER SIZE	TAP SIZE ANSI	SHANK DIA	SHANK DIA MM	SQUARE	SQUARE MM	A	C	E
61-106TD	1	0-6	0.141	3.58	0.110	2.79	.31	.98	1.26
61-108TD		8	0.168	4.27	0.131	3.33			
61-110TD		10	0.194	4.93	0.152	3.86			
61-112TD		12	0.220	5.59	0.165	4.19			
61-004TD		1/4	0.255	6.48	0.191	4.85			
61-005TD		5/16	0.318	8.08	0.238	6.05			
61-006TD		3/8	0.381	9.68	0.286	7.26			
61-007TD		7/16	0.323	8.20	0.242	6.15			
61-008TD		1/2	0.367	9.32	0.275	6.99			
61-009TD		9/16	0.429	10.90	0.322	8.18			
61-202TD		1/8 RS PIPE	0.438	11.13	0.328	8.33			
62-006TD		2	3/8	0.381	9.68	0.286			
62-007TD	7/16		0.323	8.20	0.242	6.15			
62-008TD	1/2		0.367	9.32	0.275	6.99			
62-009TD	9/16		0.429	10.90	0.322	8.18			
62-010TD	5/8		0.480	12.19	0.360	9.14			
62-011TD	11/16		0.542	13.77	0.406	10.31			
62-012TD	3/4		0.590	14.99	0.442	11.23			
62-013TD	13/16		0.652	16.56	0.489	12.42			
62-014TD	7/8		0.697	17.70	0.523	13.28			
62-204TD	1/4 PIPE		0.563	14.30	0.421	10.69			
62-206TD	3/8 PIPE		0.700	17.78	0.531	13.49			
62-208TD	1/2 PIPE		0.688	17.48	0.515	13.08			
63-012TD	3	3/4	0.590	14.99	0.442	11.23	.04	1.77	2.83
63-013TD		13/16	0.652	16.56	0.489	12.42			
63-014TD		7/8	0.697	17.70	0.523	13.28			
63-015TD		15/16	0.760	19.30	0.570	14.48			
63-016TD		1	0.800	20.32	0.600	15.24			
63-018TD		1-1/16, 1-1/8	0.896	22.76	0.672	17.07			
63-020TD		1-3/16, 1-1/4	1.021	25.93	0.766	19.46			
63-022TD		1-5/16, 1-3/8	1.108	28.14	0.831	21.11			
63-212TD		3/4 PIPE	0.906	23.01	0.679	17.25			
63-216TD		1 PIPE	1.125	28.58	0.843	21.41			

TAP & REAMER ADAPTERS



CSTA-NCI ER Collet Style Tap & Reamer Adapters Thru Coolant

Features, Application, Ordering:

- ⇒ Compatible with Bilz, Collis, Universal, Lyndex and many other tap holders.
- ⇒ Order Collets Separately—For Coolant applications a sealed collet or coolant disk nut is required.
- ⇒ DIN, ISO & JIS Available Upon Request.
- ⇒ Specials Available Upon Request.
- ⇒ Recommended for carbide taps

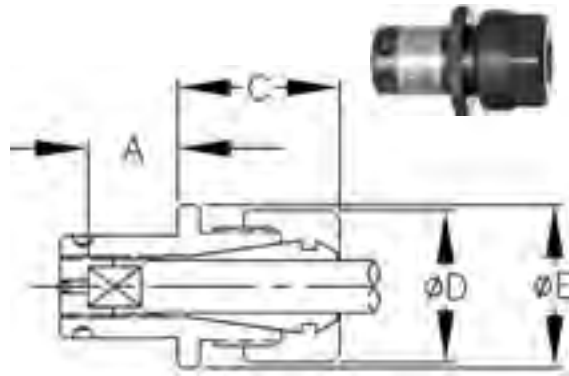

TAP ADAPTER NUMBER	ADAPTER SIZE	TAP SIZE ANSI	COLLET	DRIVE SCREW	A	C	D DIA.	E DIA.	LOCKING TORQUE
51-SA16-T004*	1	1/4	SA-16-70	PS07C-191	.34	1.17	1.10	1.18	45
51-SA16-T005		5/16	SA-16-11/32	PS07C-243	.42				
51-SA16-T006		3/8	SA-16-100	PS07C-286	.42				
51-SA16-T007*		7/16	SA-16-11/32	PS07C-243	.42				
51-SA16-T008		1/2	SA-16-3/8	PS07C-275	.42				
51-SA20-T004	1	1/4	SA-20-70	PS09C-191	.42	1.50	1.34	1.18	65
51-SA20-T005		5/16	SA-20-11/32	PS09C-243	.52				
51-SA20-T006		3/8	SA-20-100	PS09C-275	.52				
51-SA20-T007		7/16	SA-20-11/32	PS09C-243	.52				
51-SA20-T008		1/2	SA-20-3/8	PS09C-286	.52				
51-SA20-T009		9/16	SA-20-7/16	PS09C-322	.52				
51-SA20-T010		5/8	SA-20-1/2	PS09C-360	.52				
52-SA32-T009*	2	9/16	SA-32-7/16	PS14C-322	.47	1.40	1.96	1.88	100
52-SA32-T010*		5/8	SA-32-1/2	PS14C-360	.47				
52-SA32-T011*		11/16	SA-32-140	PS14C-406	.59				
52-SA32-T012*		3/4	SA-32-150	PS14C-443	.59				
52-SA32-T013*		13/16	SA-32-21/32	PS14C-489	.84				
52-SA32-T014*		7/8	SA-32-180	PS14C-523	.84				

REAMER ADAPTER NUMBER	ADAPTER SIZE	TANG SIZE	COLLET	DRIVE SCREW	A	C	D DIA.	E DIA.	LOCKING TORQUE
51-SA16-R094*	1	.094	SA-16-***	PS07C-094	.34	1.06	1.10	1.18	45
51-SA16-R122*		.122		PS07C-122	.42				
51-SA16-R162		.162		PS07C-162	.42				
51-SA16-R203		.203		PS07C-203	.42				
51-SA16-R0		STOP SCREW		PS07C	-				
51-SA20-R094	1	.094	SA-20-***	PS09C-094	.42	1.50	1.34	1.18	65
51-SA20-R122		.122		PS09C-122	.42				
51-SA20-R162		.162		PS09C-162	.42				
51-SA20-R203		.203		PS09C-203	.52				
51-SA20-R243		.243		PS09C-243	.52				
51-SA20-R303		.303		PS09C-303	.52				
51-SA20-R0		STOP SCREW		PS09C	-				
52-SA32-R162*	2	.162	SA-32-***	PS14C-162	.47	1.40	1.96	1.88	100
52-SA32-R203*		.203		PS14C-203	.47				
52-SA32-R243*		.243		PS14C-243	.59				
52-SA32-R303*		.303		PS14C-303	.59				
52-SA32-R373*		.373		PS14C-373	.84				
52-SA32-R443		.443		PS14C-443	.84				
52-SA32-R0*		STOP SCREW		PS14C	-				

TAP ADAPTERS



NTLA-ANSI Solid Direct Drive Tap Adapter Coolant Thru Adjustable Length

Features, Application, Ordering:

- ⇒ Compatible with Bilz, Collis, Universal, Lyndex and many other tap holders.
- ⇒ Coolant Thru—Note: Due to the fit between Tap Shanks and the adapter, some leakage may occur.
- ⇒ Specials Available Upon Request.
- ⇒ When ordering the NTLA with TMS-extension, give the number of the extension required; example: (Adapter) 52-009-0 with (TMS Extension) 401-000.
- ⇒ For Carbide Taps use collet style on page 33.

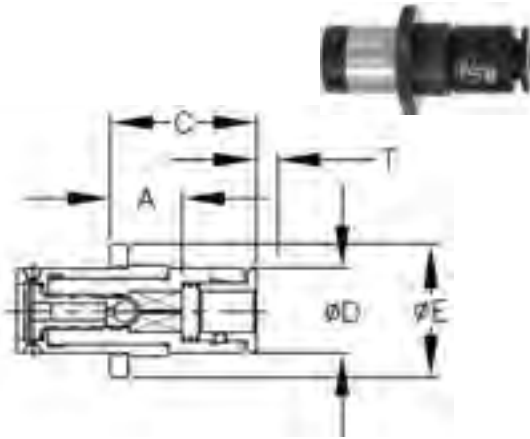

PART NUMBER	ADAPTER SIZE	TAP SIZE	SHANK DIA	SHANK DIA MM	SQUARE	SQUARE MM	A	C	T ADJUST-MENT	D	E
50-106-0*	0	0-6	.141	3.58	.110	2.79	.61	1.22	.32	.49	.86
50-108-0*		8	.168	4.27	.130	3.33					
50-110-0*		10	.194	4.93	.150	3.86					
50-112-0*		12	.220	5.59	.170	4.19					
50-004-0		1/4	.255	6.48	.190	4.85					
51-106-0*	1	0-6	.141	3.58	.110	2.79	.71	1.39	.39	.75	1.18
51-108-0		8	.168	4.27	.130	3.33					
51-110-0		10	.194	4.93	.150	3.86					
51-112-0*		12	.220	5.59	.170	4.19					
51-004-0		1/4	.255	6.48	.190	4.85					
51-005-0		5/16	.318	8.08	.240	6.05	.63	1.40	.39	.75	1.18
51-006-0		3/8	.381	9.68	.290	7.26					
51-007-0		7/16	.323	8.20	.240	6.15					
51-008-0		1/2	.367	9.32	.280	6.99					
51-009-0		9/16	.429	10.90	.320	8.18					
51-202-0	1/8 RS PIPE	.438	11.13	.330	8.33	.54	1.65	.39	.75	1.18	
52-106-0**	2	0-6	.141	3.58	.110	2.79	.46	1.08	.39	1.18	1.88
52-108-0**		8	.168	4.27	.130	3.33					
52-110-0**		10	.194	4.93	.150	3.86					
52-112-0**		12	.220	5.59	.170	4.19					
52-004-0*		1/4	.255	6.48	.190	4.85					
52-005-0*		5/16	.318	8.08	.240	6.05	.38	1.09	.39	1.18	1.88
52-006-0*		3/8	.381	9.68	.290	7.26					
52-007-0*		7/16	.323	8.20	.240	6.15					
52-008-0*		1/2	.367	9.32	.280	6.99					
52-009-0*		9/16	.429	10.90	.320	8.18					
52-010-0		5/8	.480	12.19	.360	9.14	1.15	2.34	.59	1.18	1.88
52-011-0		11/16	.542	13.77	.410	10.31					
52-012-0		3/4	.590	14.99	.440	11.23					
52-013-0		13/16	.652	16.56	.490	12.42					
52-014-0		7/8	.697	17.70	.520	13.28					
52-202-0*		1/8 RS PIPE	.438	11.13	.330	8.33	1.54	2.31	.59	1.18	1.88
52-204-0		1/4 PIPE	.563	14.30	.420	10.69	1.49	2.34	.59	1.18	1.88
52-206-0		3/8 PIPE	.700	17.78	.530	13.49					
52-208-0		1/2 PIPE	.688	17.48	.520	13.08					

**Recommended for rigid or holders set to light compensation.

TAP ADAPTERS



NTLA-ANSI Tension Direct Drive Tap Adapter Adjustable Length

Features, Application, Ordering:

- ⇒ Compatible with Bilz, Collis, Universal, Lyndex and many other tap holders.
- ⇒ Specials Available Upon Request.
- ⇒ When ordering the NTLA with TMS-extension, give the number of the extension required; example: (Adapter) 52-009-0 with (TMS Extension) 401-000.
- ⇒ For Carbide Taps use collet style on page 33.

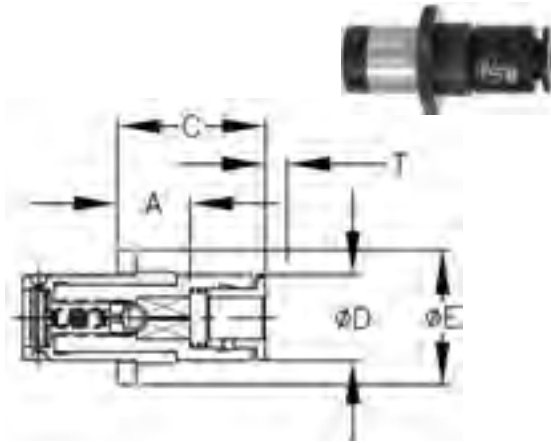

PART NUMBER	ADAPTER SIZE	TAP SIZE	SHANK DIA	SHANK DIA MM	SQUARE	SQUARE MM	A	C	T TENSION	D	E
51-106-0-T*	1	0-6	.141	3.58	.110	2.79	.71	1.39	.39	.75	1.18
51-108-0-T*		8	.168	4.27	.130	3.33					
51-110-0-T*		10	.194	4.93	.150	3.86					
51-112-0-T*		12	.220	5.59	.170	4.19					
51-004-0-T*		1/4	.255	6.48	.190	4.85					
51-005-0-T*		5/16	.318	8.08	.240	6.05	.63	1.40			
51-006-0-T*		3/8	.381	9.68	.290	7.26					
51-007-0-T*		7/16	.323	8.20	.240	6.15					
51-008-0-T*		1/2	.367	9.32	.280	6.99					
51-009-0-T*		9/16	.429	10.90	.320	8.18		.54			
51-202-0-T*		1/8 RS PIPE	.438	11.13	.330	8.33					

TAP ADAPTERS



TMS-EXT Adapter Length Extensions

Features, Application, Ordering:

- ⇒ Coolant Thru Design.
- ⇒ Tension Option Available—See chart below.
- ⇒ Provides additional length to NTLA tap adapters & 400 Series holders as required.
- ⇒ Pre-Assembled to tap adapter upon request.
Example on ordering assemblies:
1) 51-004-0 with 401-001 = 51-004-0-1
2) 401-004-212 with 401-000 = 401-004-212-0
- ⇒ Specials Available Upon Request.

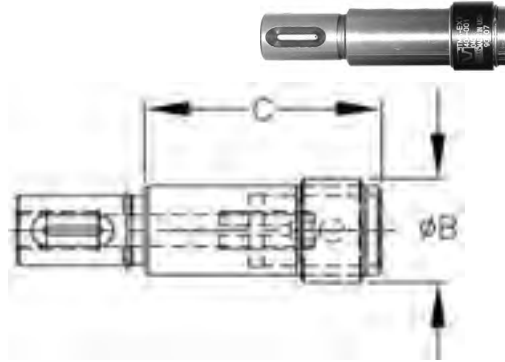

TMS-EXT Adapter Length Extensions with Tension

Features, Application, Ordering:

- ⇒ Tension Option Available—Order extension with “-T” at the end of the part number. Must be ordered with adapter or holder and assembled at T.M. Smith Tool. See chart below for part numbers.
Example on ordering assemblies:
1) 51-004-0 with 401-002T = 51-004-0-2-T
2) 401-004-212 with 401-001T = 401-004-212-1-T
- ⇒ Provides additional length to NTLA tap adapters & 400 Series holders as required.
- ⇒ Specials Available Upon Request.

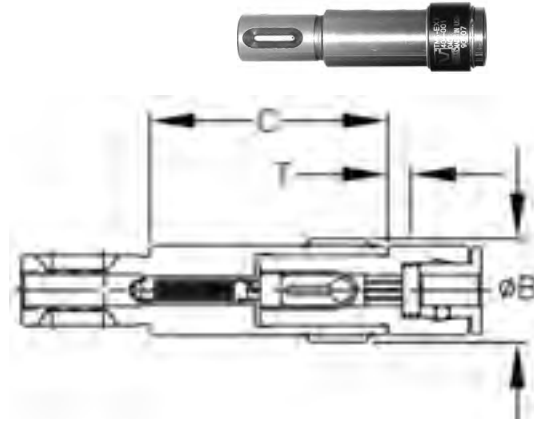

PART NUMBER	B DIA	C	TENSION AVAILABLE	T TENSION
400-000*	.50	1.06	NO	.28
400-001*		1.69	YES	
400-002*		2.32		
401-000	.87	1.185	NO	.39
401-001		1.985	YES	
401-002		2.785		
401-003		3.585		
401-004		4.385		
401-005*		5.185		
401-006*		5.985		
401-007*		6.785		
401-008*		7.585		
402-000*		1.18		
402-001*	3.070			
402-002*	4.250			
402-003*	5.430			

TAP & REAMER ADAPTERS



CSTA Collet Style Tap Adapter Thru Coolant



Features, Application, Ordering:

- ⇒ Compatible with Bilz, Collis, Universal, Lyndex and many other tap holders.
- ⇒ Order Collets Separately—For Coolant applications a sealed collet or coolant disk nut is required.
- ⇒ For optimal performance collet nut must be tightened to proper operating torque. 45 lbs for SA16, 100 lbs for SA32.
- ⇒ DIN, ISO & JIS Available Upon Request.
- ⇒ Specials Available Upon Request.
- ⇒ Reamer Adapters Available Upon Request.
- ⇒ Recommended for carbide taps

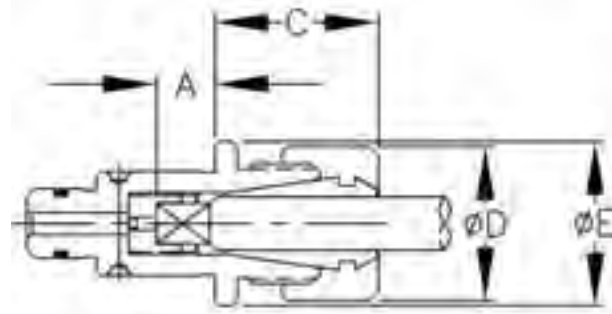

TAP ADAPTER NUMBER	ADAPTER SIZE	TAP SIZE ANSI	COLLET	DRIVE SCREW	A	C	D DIA.	E DIA.
51-SA16-004*	1	1/4	SA-16-70	PS07C-191	.34	1.06	1.10	1.18
51-SA16-005*		5/16	SA-16-90	PS07C-243	.42			
51-SA16-006*		3/8	SA-16-100	PS07C-286	.42			
51-SA16-007*		7/16	SA-16-90	PS07C-243	.42			
51-SA16-008*		1/2	SA-16-100	PS07C-286	.42			
52-SA16-004*	2	1/4	SA-16-70	PS07C-191	.34	1.10	1.10	1.88
52-SA16-005*		5/16	SA-16-90	PS07C-243	.42			
52-SA16-006*		3/8	SA-16-100	PS07C-286	.42			
52-SA16-007*		7/16	SA-16-90	PS07C-243	.42			
52-SA16-008*		1/2	SA-16-100	PS07C-286	.42			
52-SA32-009*	2	9/16	SA-32-110	PS14C-322	.47	1.40	1.96	1.88
52-SA32-010*		5/8	SA-32-130	PS14C-360	.47			
52-SA32-011*		11/16	SA-32-140	PS14C-406	.59			
52-SA32-012*		3/4	SA-32-150	PS14C-443	.59			
52-SA32-013*		13/16	SA-32-170	PS14C-489	.84			
52-SA32-014*		7/8	SA-32-180	PS14C-523	.84			

COLLETS



The ER collet system used by T.M. Smith Tool offers a variety of advantages including accuracy, availability, flexibility and standardization. ER collets can be purchased in standard, exact-size, ultra-precision, and sealed versions. T.M. Smith offers ER collets in 1-millimeter increments as a shelf-stock, standard product. Our standard collets are actually precision collets. This provides the highest accuracy and gripping force, at the least cost and fastest delivery possible.

Standard Collets: They are offered in 1-millimeter increments as a standard, shelf-stock item. This provides collets that are ground "round and true" at the major diameter.

Exact-Size Collets (ES): Exact-size collets are ground to exactly the diameter specified. These collets are traditionally used when gripping force is a primary concern. Use exact size collets only when conditions indicate that they are truly needed. Remember that exact-size affects gripping power, not accuracy and run-out.

Ultra-Precision Collets (UP): These collets are manufactured for 1/2 the run out of a standard collet. The UP collets should be used where accuracy and reduced run-out are critical. For Ultra Precision collets to work properly they must stay as concentric as possible. The manufacturing of these collets is critical and the collets are ground at the size of the cutting tool to improve the accuracy. T.M. Smith requires the cutter tool shank size when ordering these collets. The designation on the collet will be ESUP (Exact Size Ultra Precision).



Sealed Collets (S): Sealed collets provide a sealed system to deliver the coolant through the cutting end of the tool to the part. The T.M. Smith ER system uses a sealing method that utilizes a sealing material inserted into the front angle of the collet and 4 slots from each end. This allows the collet to collapse without over squeezing the sealant into the I.D. of the collet pocket, which affects its collapsibility and accuracy. By sealing at the front of the collet angle and only using 8 slots in the collet, we reduce any negative impact on the accuracy of the cutting tool. Due to the improved design of 8 slots, T.M. Smith requires the cutter tool shank size when ordering these collets.

Ordering Information: Examples: ER-16. 7.0 mm Collet

Standard	SA-16- 70
*Ultra Precision.....	SA-16-70-UP
*Exact Size	Order ESUP Style
*Exact Size, Ultra-Precision.....	SA-16- 70-ESUP
Sealed	SA-16-70-S
*Sealed, Ultra Precision.....	SA-16-70-SUP
*Sealed, Exact Size	Order SESUP Style
*Sealed, Exact Size, Ultra-Precision	SA-16-70-SESUP

* Cutter tool shank size required when ordering these options.

Coolant Thru has been a specialty at T.M. Smith for many years and we have several options for your application. These options include:

- ⇒ Rubber Sealed Collets (1000 PSI Max)
- ⇒ Steel Seal Collets (1500 PSI Max)
- ⇒ Coolant Disk Nut System (1500 PSI Max)

COLLETS



ER (SA) Collets Metric Bore Sizes

- ⇒ Collets can be ordered separately or in sets see page 47.
- ⇒ To order separately, specify Collet Series and I.D. size.
Example: SA16-50 represents a SA16 Series with a 5.0mm I.D.
- ⇒ Sealed Collets available on the following page.
- ⇒ Collets 100% compatible with ER collet chucks.

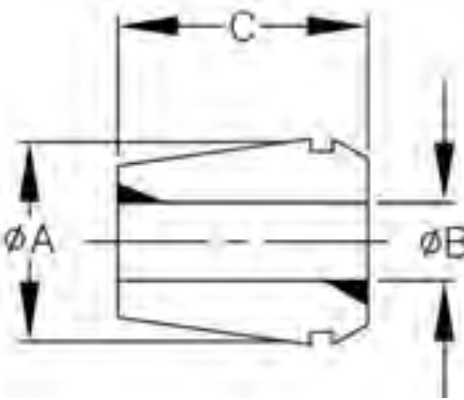

SERIES	A GAGE-LINE	B MAX	C
SA11	.4330	.2756	.728
SA16	.6299	.3937	1.083
SA20	.7874	.5118	1.240
SA25	.9843	.6299	1.339
SA32	1.2598	.7874	1.575
SA40	1.5748	1.1811	1.811

COLLET BORE SIZE		SA11	COLLET BORE SIZE			SA16	SA20	SA25	SA32	SA40
INCH	METRIC		FRACTIONAL	INCH	METRIC					
.020/.039	0.501/1.000	SA-11-10		1/32	.020-.039	0.5-1.0	SA16-10			
.040/.059	1.001/1.500	SA-11-15		1/16	.040-.079	1.0-2.0	SA16-20	SA20-20	SA25-20	
.060/.079	1.501/2.000	SA-11-20		3/32	.080-.118	2.0-3.0	SA16-30	SA20-30	SA25-30	SA32-30
.080/.098	2.001/2.500	SA-11-25	1/8	5/32	.119-.157	3.0-4.0	SA16-40	SA20-40	SA25-40	SA32-40
.099/.118	2.501/3.000	SA-11-30		3/16	.158-.197	4.0-5.0	SA16-50	SA20-50	SA25-50	SA32-50
.118/.137	3.001/3.500	SA-11-35		7/32	.198-.236	5.0-6.0	SA16-60	SA20-60	SA25-60	SA32-60
.138/.157	3.501/4.000	SA-11-40	1/4		.237-.275	6.0-7.0	SA16-70	SA20-70	SA25-70	SA32-70
.158/.177	4.001/4.500	SA-11-45		5/16	.276-.315	7.0-8.0	SA16-80	SA20-80	SA25-80	SA32-80
.178/.197	4.501/5.000	SA-11-50		11/32	.316-.354	8.0-9.0	SA16-90	SA20-90	SA25-90	SA32-90
.198/.216	5.001/5.500	SA-11-55	3/8		.355-.393	9.0-10.0	SA16-100	SA20-100	SA25-100	SA32-100
.217-.236	5.501/6.000	SA-11-60		13/32	.394-.433	10.0-11.0		SA20-110	SA25-110	SA32-110
.237-.255	6.001/6.500	SA-11-65		7/16	.434-.472	11.0-12.0		SA20-120	SA25-120	SA32-120
.256-.276	6.501/7.000	SA-11-70	1/2		.473-.511	12.0-13.0		SA20-130	SA25-130	SA32-130
				17/32	.512-.551	13.0-14.0		SA25-140	SA32-140	SA40-140
				9/16	.552-.590	14.0-15.0		SA25-150	SA32-150	SA40-150
			5/8		.591-.629	15.0-16.0		SA25-160	SA32-160	SA40-160
				21/32	.630-.669	16.0-17.0			SA32-170	SA40-170
				11/16	.670-.708	17.0-18.0			SA32-180	SA40-180
			3/4		.709-.748	18.0-19.0			SA32-190	SA40-190
				25/32	.749-.787	19.0-20.0			SA32-200	SA40-200
				13/16	.788-.826	20.0-21.0				SA40-210
				27/32	.827-.866	21.0-22.0				SA40-220
			7/8		.867-.905	22.0-23.0				SA40-230
				15/16	.906-.944	23.0-24.0				SA40-240
				31/32	.945-.984	24.0-25.0				SA40-250
			1"		.985-1.02	25.0-26.0				SA40-260

ULTRA PRECISION COLLETS

- ⇒ Ultra Precision Collets available upon request.
- ⇒ To order add "UP" at the end of the part number.
Example: SA16-70-UP
- ⇒ Non Stock.

A BORE SIZE	D DISTANCE FROM COLLET FACE	T PRECISION RUNOUT	T ULTRA PRECISION RUNOUT
.125	.50	.0004	.0002
.250	1.00	.0004	.0002
.375	1.50	.0004	.0002
.500	2.00	.0008	.0004

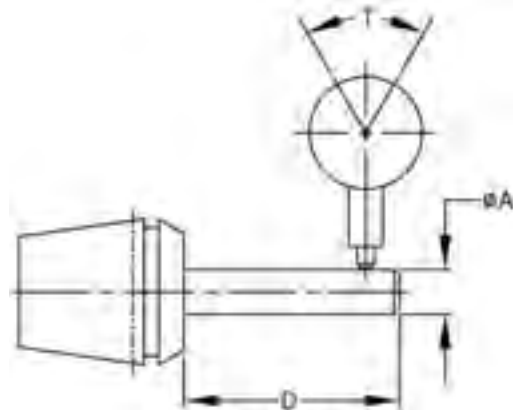

COLLETS



ER (SA) Collets Inch Bore Sizes

- ⇒ Collets can be ordered separately or in sets see page 47.
- ⇒ To order separately, specify Collet Series and I.D. size.
Example: SA16-50 represents a SA16 Series with a 5.0mm I.D.
- ⇒ Sealed Collets available on the following page.
- ⇒ Collets 100% compatible with ER collet chucks.

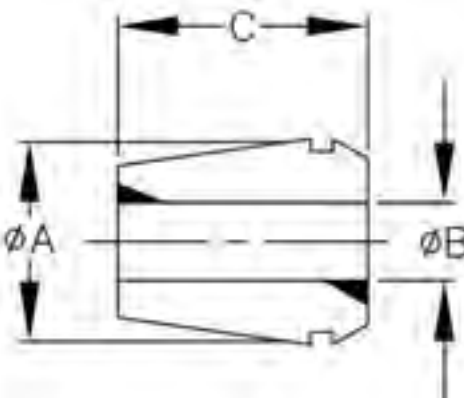

SERIES	A GAGE-LINE	B MAX	C
SA11	.4330	.2756	.728
SA16	.6299	.3937	1.083
SA20	.7874	.5118	1.240
SA25	.9843	.6299	1.339
SA32	1.2598	.7874	1.575
SA40	1.5748	1.1811	1.811

COLLET BORE SIZE				SA11	SA16	SA20	SA25	SA32	SA40
FRACTIONAL	INCH	METRIC							
	1/16	.0625-.0428	1.588-1.087	SA11-1/16	SA16-1/16				
	3/32	.0937-.0544	2.380-1.382	SA11-3/32	SA16-3/32	SA20-3/32	SA25-3/32	SA32-3/32	
1/8		.1250-.0856	3.175-2.174	SA11-1/8	SA16-1/8	SA20-1/8	SA25-1/8	SA32-1/8	SA40-1/8
	5/32	.1562-.1169	3.967-2.969	SA11-5/32	SA16-5/32	SA20-5/32	SA25-5/32	SA32-5/32	SA40-5/32
	3/16	.1875-.1481	4.762-3.762	SA11-3/16	SA16-3/16	SA20-3/16	SA25-3/16	SA32-3/16	SA40-3/16
	7/32	.2187-.1794	5.555-4.557	SA11-7/32	SA16-7/32	SA20-7/32	SA25-7/32	SA32-7/32	SA40-7/32
1/4		.2500-.2106	6.350-5.349	SA11-1/4	SA16-1/4	SA20-1/4	SA25-1/4	SA32-1/4	SA40-1/4
	9/32	.2812-.2418	7.142-6.142		SA16-9/32	SA20-9/32	SA25-9/32	SA32-9/32	SA40-9/32
	5/16	.3125-.2731	7.938-6.937		SA16-5/16	SA20-5/16	SA25-5/16	SA32-5/16	SA40-5/16
	11/32	.3437-.3044	8.730-7.732		SA16-11/32	SA20-11/32	SA25-11/32	SA32-11/32	SA40-11/32
3/8		.3750-.3356	9.525-8.524		SA16-3/8	SA20-3/8	SA25-3/8	SA32-3/8	SA40-3/8
	13/32	.4062-.3669	10.317-9.319		SA16-13/32	SA20-13/32	SA25-13/32	SA32-13/32	SA40-13/32
	7/16	.4375-.3981	11.112-10.112			SA20-7/16	SA25-7/16	SA32-7/16	SA40-7/16
	15/32	.4687-.4294	11.905-10.907			SA20-15/32	SA25-15/32	SA32-15/32	SA40-15/32
1/2		.5000-.4606	12.700-11.699			SA20-1/2	SA25-1/2	SA32-1/2	SA40-1/2
	17/32	.5312-.4918	13.492-12.492				SA25-17/32	SA32-17/32	SA40-17/32
	9/16	.5625-.5231	14.287-13.287				SA25-9/16	SA32-9/16	SA40-9/16
	19/32	.5937-.5544	15.080-14.082				SA25-19/32	SA32-19/32	SA40-19/32
5/8		.6250-.5856	15.875-14.875				SA25-5/8	SA32-5/8	SA40-5/8
	21/32	.6562-.6169	16.667-15.669					SA32-21/32	SA40-21/32
	11/16	.6875-.6481	17.462-16.462					SA32-11/16	SA40-11/16
	23/32	.7187-.6794	18.255-17.257					SA32-23/32	SA40-23/32
3/4		.7500-.7106	19.050-18.050					SA32-3/4	SA40-3/4
7/8		.8750-.8356	22.225-21.224						SA40-7/8
1"		1.0000-.9606	25.400-24.399						SA40-1"

ULTRA PRECISION COLLETS

- ⇒ Ultra Precision Collets available upon request.
- ⇒ To order add "UP" at the end of the part number.
Example: SA16-3/8-UP
- ⇒ Non Stock.

A BORE SIZE	D DISTANCE FROM COLLET FACE	T PRECISION RUNOUT	T ULTRA PRECISION RUNOUT
.125	.50	.0004	.0002
.250	1.00	.0004	.0002
.375	1.50	.0004	.0002
.500	2.00	.0008	.0004

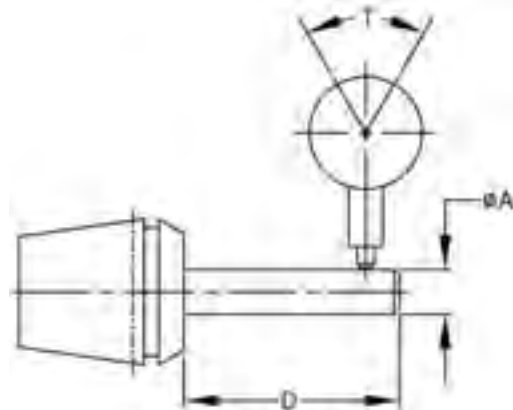

COLLETS



ER (SA) Rubber Sealed Collets



- ⇒ Collets can be ordered separately or in sets see page 46
- ⇒ To order separately, specify Collet Series and I.D. size.
Example: SA16-50-S represents a SA16 Series with a 5.0mm I.D. with a -S designates rubber sealed.
- ⇒ Ultra-Precision available upon request.
- ⇒ Standard collets available on the previous page.
- ⇒ Steel Sealed collets available on the following page.
- ⇒ Collets 100% compatible with ER collet chucks.

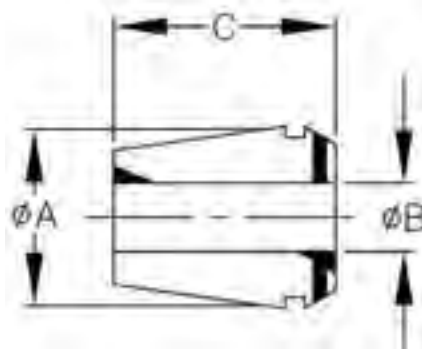

SERIES	A GAGE-LINE	B MAX	C
SA16	.6299	.3937	1.083
SA20	.7874	.5118	1.240
SA25	.9843	.6299	1.339
SA32	1.2598	.7874	1.575
SA40	1.5748	1.1811	1.811

COLLET BORE SIZE				SA16	SA20	SA25	SA32	SA40
FRACTIONAL		INCH	METRIC					
		.0985-.1181	2.501-3.000	SA-16-30-S	SA-20-30-S	SA-25-30-S	SA-32-30-S	
1/8		.1182-.1377	3.001-3.500	SA-16-35-S	SA-20-35-S	SA-25-35-S	SA-32-35-S	
	5/32	.1378-.1574	3.501-4.000	SA-16-40-S	SA-20-40-S	SA-25-40-S	SA-32-40-S	
		.1575-.1771	4.001-4.500	SA-16-45-S	SA-20-45-S	SA-25-45-S	SA-32-45-S	
	3/16	.1772-.1968	4.501-5.000	SA-16-50-S	SA-20-50-S	SA-25-50-S	SA-32-50-S	
		.1969-.2165	5.001-5.500	SA-16-55-S	SA-20-55-S	SA-25-55-S	SA-32-55-S	
	7/32	.2166-.2362	5.501-6.000	SA-16-60-S	SA-20-60-S	SA-25-60-S	SA-32-60-S	SA-40-60-S
1/4		.2363-.2559	6.001-6.500	SA-16-65-S	SA-20-65-S	SA-25-65-S	SA-32-65-S	SA-40-65-S
		.2559-.2756	6.501-7.000	SA-16-70-S	SA-20-70-S	SA-25-70-S	SA-32-70-S	SA-40-70-S
	9/32	.2756-.2953	7.001-7.500	SA-16-75-S	SA-20-75-S	SA-25-75-S	SA-32-75-S	SA-40-75-S
	5/16	.2953-.3150	7.501-8.000	SA-16-80-S	SA-20-80-S	SA-25-80-S	SA-32-80-S	SA-40-80-S
		.3150-.3346	8.001-8.500	SA-16-85-S	SA-20-85-S	SA-25-85-S	SA-32-85-S	SA-40-85-S
	11/32	.3347-.3543	8.501-9.000	SA-16-90-S	SA-20-90-S	SA-25-90-S	SA-32-90-S	SA-40-90-S
		.3544-.3740	9.001-9.500	SA-16-95-S	SA-20-95-S	SA-25-95-S	SA-32-95-S	SA-40-95-S
3/8		.3741-.3937	9.501-10.000	SA-16-100-S	SA-20-100-S	SA-25-100-S	SA-32-100-S	SA-40-100-S
	13/32	.3937-.4134	10.001-10.500		SA-20-105-S	SA-25-105-S	SA-32-105-S	SA-40-105-S
		.4134-.4331	10.501-11.000		SA-20-110-S	SA-25-110-S	SA-32-110-S	SA-40-110-S
	7/16	.4331-.4528	11.001-11.500		SA-20-115-S	SA-25-115-S	SA-32-115-S	SA-40-115-S
	15/32	.4528-.4724	11.501-12.000		SA-20-120-S	SA-25-120-S	SA-32-120-S	SA-40-120-S
		.4725-.4921	12.001-12.500		SA-20-125-S	SA-25-125-S	SA-32-125-S	SA-40-140-S
1/2		.4922-.5118	12.501-13.000		SA-20-130-S	SA-25-130-S	SA-32-130-S	SA-40-130-S
		.5119-.5315	13.001-13.500			SA-25-135-S	SA-32-135-S	SA-40-135-S
	17/32	.5315-.5512	13.501-14.000			SA-25-140-S	SA-32-140-S	SA-40-140-S
	9/16	.5512-.5709	14.001-14.500			SA-25-145-S	SA-32-145-S	SA-40-145-S
		.5709-.5906	14.501-15.000			SA-25-150-S	SA-32-150-S	SA-40-150-S
	19/32	.5906-.6102	15.001-15.500			SA-25-155-S	SA-32-155-S	SA-40-155-S
5/8		.6103-.6299	15.501-16.000			SA-25-160-S	SA-32-160-S	SA-40-160-S
		.6300-.6496	16.001-16.500				SA-32-165-S	SA-40-165-S
	21/32	.6496-.6693	16.501-17.000				SA-32-170-S	SA-40-170-S
	11/16	.6693-.6890	17.001-17.500				SA-32-175-S	SA-40-175-S
		.6890-.7087	17.501-18.000				SA-32-180-S	SA-40-180-S
	23/32	.7087-.7283	18.001-18.500				SA-32-185-S	SA-40-185-S
		.7284-.7480	18.501-19.000				SA-32-190-S	SA-40-190-S
3/4		.7481-.7677	19.001-19.500				SA-32-195-S	SA-40-195-S
	25/32	.7678-.7874	19.501-20.000				SA-32-200-S	SA-40-200-S
		.7875-.8070	20.001-20.500					SA-40-205-S
	13/16	.8071-.8267	20.501-21.000					SA-40-210-S
	27/32	.8268-.8464	21.001-21.500					SA-40-215-S
		.8465-.8661	21.501-22.000					SA-40-220-S
7/8		.8662-.8858	22.001-22.500					SA-40-225-S
		.8859-.9055	22.501-23.000					SA-40-230-S
	29/32	.9056-.9252	23.001-23.500					SA-40-235-S
	15/16	.9253-.9448	23.501-24.000					SA-40-240-S
		.9449-.9645	24.001-24.500					SA-40-245-S
	31/32	.9646-.9842	24.501-25.000					SA-40-250-S
1"		.9843-1.0039	25.001-25.500					SA-40-255-S
		1.0040-1.0236	25.501-26.000					SA-40-260-S

COLLETS



ER (SA) Steel Sealed Collets

- ⇒ To order separately, specify Collet Series and I.D. size.
Example: SASS16-3/32 represents a SASS16 Series with a 3/32 Inch I.D.
- ⇒ Standard collets available on the previous page.
- ⇒ Collets 100% compatible with ER collet chucks.
- ⇒ Special Size collets available upon request.
- ⇒ Collets seal to 2000 PSI
- ⇒ Collets can be used with any standard ER.RD,DR,ESX or BR Collet Chucks for coolant Thru applications

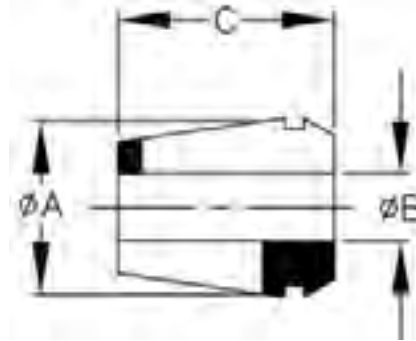

SERIES	A GAGE-LINE	B MAX	C
SA16	.6299	.3937	1.083
SA20	.7874	.5118	1.240
SA25	.9843	.6299	1.339
SA32	1.2598	.7874	1.575
SA40	1.5748	1.1811	1.811

COLLET BORE SIZE	SA16	SA20	SA25	SA32	SA40
FRACTIONAL					
3/32	SASS16-3/32				
1/8	SASS16-1/8				
5/32	SASS16-5/32	SASS20-5/32			
3/16	SASS16-3/16	SASS20-3/16			
7/32	SASS16-7/32	SASS20-7/32	SASS25-7/32		
1/4	SASS16-1/4	SASS20-1/4	SASS25-1/4	SASS32-1/4	
9/32	SASS16-9/32	SASS20-9/32	SASS25-9/32	SASS32-9/32	
5/16	SASS16-5/16	SASS20-5/16	SASS25-5/16	SASS32-5/16	
11/32	SASS16-11/32	SASS20-11/32	SASS25-11/32	SASS32-11/32	
3/8	SASS16-3/8	SASS20-3/8	SASS25-3/8	SASS32-3/8	SASS40-3/8
13/32	SASS16-13/32	SASS20-13/32	SASS25-13/32	SASS32-13/32	SASS40-13/32
7/16		SASS20-7/16	SASS25-7/16	SASS32-7/16	SASS40-7/16
15/32		SASS20-15/32	SASS25-15/32	SASS32-15/32	SASS40-15/32
1/2		SASS20-1/2	SASS25-1/2	SASS32-1/2	SASS40-1/2
17/32			SASS25-17/32	SASS32-17/32	SASS40-17/32
9/16			SASS25-9/16	SASS32-9/16	SASS40-9/16
19/32			SASS25-19/32	SASS32-19/32	SASS40-19/32
5/8			SASS25-5/8	SASS32-5/8	SASS40-5/8
21/32				SASS32-21/32	SASS40-21/32
11/16				SASS32-11/16	SASS40-11/16
23/32				SASS32-23/32	SASS40-23/32
3/4				SASS32-3/4	SASS40-3/4
7/8					SASS40-7/8
1					SASS40-1

COLLETS



ER (SA) Tap Collets - ANSI

- ⇒ Collets can be ordered separately or in sets.
- ⇒ To order separately, specify Collet Series and I.D. size. Example: SA16-TR005 represents a SA16 Series with a 5/16 Hand Tap I.D.
- ⇒ Collets are for ANSI Tap Shanks.
- ⇒ Collets 100% compatible with ER collet chucks.

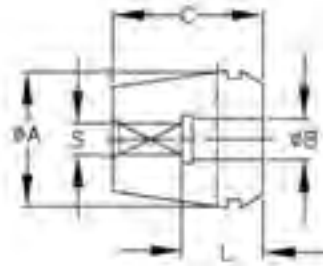

SERIES	A GAGE-LINE	C
SA16	.6299	1.083
SA20	.7874	1.240
SA25	.9843	1.339
SA32	1.2598	1.575
SA40	1.5748	1.811

TAP INCH	ANSI METRIC	B SHANK	S SQUARE	L TAP ENTERS	SA16	SA20	SA25	SA32	SA40	
#8	M4	.168	.131	.71	SA16-TR108	SA20-TR108	SA25-TR108	SA32-TR108		
#10	M5	.194	.152		SA16-TR110	SA20-TR110	SA25-TR110	SA32-TR110		
1/4	M6	.255	.191		SA16-TR004	SA20-TR004	SA25-TR004	SA32-TR004	SA40-TR004	
5/16	M7	.318	.238	.87		SA20-TR005	SA25-TR005	SA32-TR005	SA40-TR005	
3/8	M10	.381	.286			SA20-TR006	SA25-TR006	SA32-TR006	SA40-TR006	
7/16		.323	.242			SA20-TR007	SA25-TR007	SA32-TR007	SA40-TR007	
1/2	M12	.367	.275			SA20-TR008	SA25-TR008	SA32-TR008	SA40-TR008	
9/16	M14	.429	.322	.98			SA25-TR009	SA32-TR009	SA40-TR009	
5/8	M16	.480	.360				SA25-TR010	SA32-TR010	SA40-TR010	
11/16	M18	.542	.406					SA32-TR011	SA40-TR011	
3/4		.590	.442					SA32-TR012	SA40-TR012	
13/16	M20	.652	.489					SA32-TR013	SA40-TR013	
7/8	M22	.697	.523						SA40-TR014	
15/16	M24	.760	.570						SA40-TR015	
1"	M25	.800	.600						SA40-TR016	
1/8 PIPE		.437	.328					SA25-TR202	SA32-TR202	SA40-TR202
1/4 PIPE		.562	.421						SA32-TR204	SA40-TR204
3/8 PIPE		.700	.531						SA40-TR206	
1/2 PIPE		.687	.515	1.10					SA40-TR208	

DIN, JIS, ISO, STANDARDS ALSO AVAILABLE

COLLETS



TG100 (SG10) Collets

- ⇒ Collets can be ordered separately or in sets see page 47.
- ⇒ To order separately, specify Collet Series and I.D. size.
Example: SG10-0094 represents a SG10 Series with a .0937 I.D.
- ⇒ To order sets see collet numbers below.
- ⇒ Collets 100% Compatible with Kennametal Erickson collets.

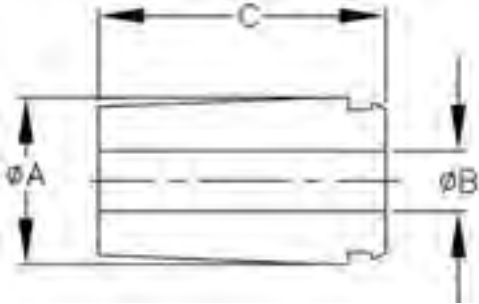

COLLET SERIES	A GAGELINE	B MAX	C
SG10	1.373	1.0000	2.375

COLLET BORE SIZE				SG SERIES COLLET	
FRACTIONAL		DEC.			
		3/32		.0937	SG10-0094
			7/64	.1094	SG10-0109
1/8				.1250	SG10-0125
			9/64	.1406	SG10-0141
		5/32		.1562	SG10-0156
			11/64	.1719	SG10-0172
	3/16			.1875	SG10-0187
			13/64	.2031	SG10-0203
			7/32	.2188	SG10-0219
			15/64	.2344	SG10-0234
1/4				.2500	SG10-0250
			17/64	.2656	SG10-0266
			9/32	.2812	SG10-0281
			19/64	.2969	SG10-0297
	5/16			.3125	SG10-0312
			21/64	.3281	SG10-0328
			11/32	.3438	SG10-0344
			23/64	.3594	SG10-0359
3/8				.3750	SG10-0375
			25/64	.3906	SG10-0391
			13/32	.4062	SG10-0406
			27/64	.4219	SG10-0422
		7/16		.4375	SG10-0437
			29/64	.4531	SG10-0453
			15/32	.4688	SG10-0469
			31/64	.4844	SG10-0484
1/2				.5000	SG10-0500
			33/64	.5156	SG10-0516
			17/32	.5312	SG10-0531
			35/64	.5469	SG10-0547
	9/16			.5625	SG10-0562
			37/64	.5781	SG10-0578
			19/32	.5938	SG10-0594
			39/64	.6094	SG10-0609
5/8				.6250	SG10-0625
			41/64	.6406	SG10-0641
			21/32	.6562	SG10-0656
			43/64	.6719	SG10-0672
		11/16		.6875	SG10-0688
			45/64	.7031	SG10-0703
			23/32	.7188	SG10-0719
			47/64	.7344	SG10-0734
3/4				.7500	SG10-0750
			49/64	.7656	SG10-0765
			25/32	.7812	SG10-0781
			51/64	.7969	SG10-0796
	13/16			.8125	SG10-0812
			53/64	.8281	SG10-0828
			27/32	.8438	SG10-0843
			55/64	.8594	SG10-0859
7/8				.8750	SG10-0875
			57/64	.8906	SG10-0890
			29/32	.9062	SG10-0906
			59/64	.9219	SG10-0921
	15/16			.9375	SG10-0937
			61/64	.9531	SG10-0953
			31/32	.9688	SG10-0968
			63/64	.9844	SG10-0984
1"				1.000	SG10-1000

COLLETS



TG150 (SG15) Collets

- ⇒ Collets can be ordered separately or in sets see page 47.
- ⇒ To order separately, specify Collet Series and I.D. size.
Example: SG15-0500 represents a SG15 Series with a .5000 I.D.
- ⇒ To order sets see collet numbers below.
- ⇒ Collets 100% Compatible with Kennametal Erickson collets.

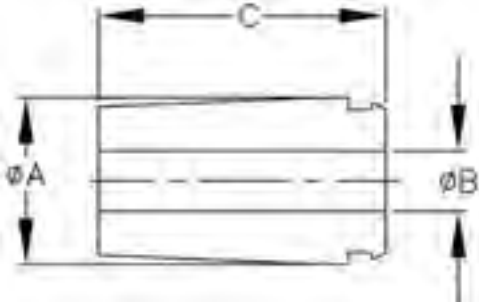

COLLET SERIES	A GAGELINE	B MAX	C
SG15	1.996	1.500	3.00

COLLET BORE SIZE				SG SERIES COLLET
FRACTIONAL		DEC.		
1/2			.5000	SG15-0500
		33/64	.5156	SG15-0516
		17/32	.5312	SG15-0531
		35/64	.5469	SG15-0547
	9/16		.5625	SG15-0562
		37/64	.5781	SG15-0578
		19/32	.5938	SG15-0594
		39/64	.6094	SG15-0609
5/8			.6250	SG15-0625
		41/64	.6406	SG15-0641
		21/32	.6562	SG15-0656
		43/64	.6719	SG15-0672
	11/16		.6875	SG15-0688
		45/64	.7031	SG15-0703
		23/32	.7188	SG15-0719
		47/64	.7344	SG15-0734
3/4			.7500	SG15-0750
		49/64	.7656	SG15-0765
		25/32	.7812	SG15-0781
		51/64	.7969	SG15-0796
	13/16		.8125	SG15-0812
		53/64	.8281	SG15-0828
		27/32	.8438	SG15-0843
		55/64	.8594	SG15-0859
7/8			.8750	SG15-0875
		57/64	.8906	SG15-0890
		29/32	.9062	SG15-0906
		59/64	.9219	SG15-0921
	15/16		.9375	SG15-0937
		61/64	.9531	SG15-0953
		31/32	.9688	SG15-0968
		63/64	.9844	SG15-0984
1"			1.000	SG15-1000
		1-1/64	1.0156	SG15-1015
		1-1/32	1.0312	SG15-1031
		1-3/64	1.0469	SG15-1047
	1-1/16		1.0625	SG15-1062
		1-5/64	1.0781	SG15-1078
		1-3/32	1.0937	SG15-1094
		1-7/64	1.1094	SG15-1109
1-1/8			1.1250	SG15-1125
		1-9/64	1.1406	SG15-1141
		1-5/32	1.1562	SG15-1156
		1-11/64	1.1719	SG15-1172
	1-3/16		1.1875	SG15-1187
		1-13/64	1.2031	SG15-1203
		1-7/32	1.2188	SG15-1219
		1-15/64	1.2344	SG15-1234
1-1/4			1.2500	SG15-1250
		1-17/64	1.2656	SG15-1266
		1-9/32	1.2812	SG15-1281
		1-19/64	1.2969	SG15-1297
	1-5/16		1.3125	SG15-1312
		1-21/64	1.3281	SG15-1328
		1-11/32	1.3438	SG15-1344
		1-23/64	1.3594	SG15-1359
1-3/8			1.3750	SG15-1375
		1-25/64	1.3906	SG15-1391
		1-13/32	1.4062	SG15-1406
		1-27/64	1.4219	SG15-1422
	1-7/16		1.4375	SG15-1437
		1-29/64	1.4531	SG15-1453
		1-15/32	1.4688	SG15-1469
		1-31/64	1.4844	SG15-1484
1-1/2			1.5000	SG15-1500

COLLETS



DA Collets

- ⇒ Collets can be ordered separately or in sets see page 47.
- ⇒ To order separately, specify Collet Series and I.D. size. Example: DA18-0062 represents a DA18 series with a 0625 I.D.
- ⇒ To order sets see order number above.
- ⇒ Collets 100% Compatible with Kennametal Erickson collets.

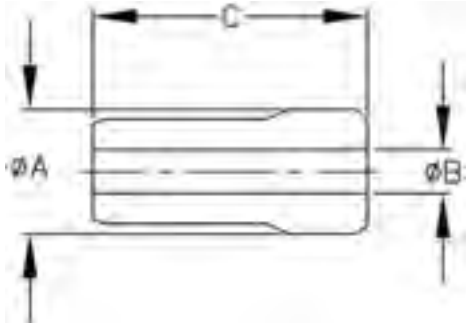

COLLET SERIES	A GAGELINE	B MAX	C
DA30	.375	.250	1.000
DA20	.531	.375	1.188
DA10	.769	.563	1.438
DA18	1.035	.750	1.625

I.D.		DA-18 SERIES	DA-10 SERIES	DA-20 SERIES	DA-30 SERIES
FRACTIONS	DEC.				
	3/64	.0468			DA30-0047
1/16		.0625	DA18-0062	DA10-0062	DA20-0062
	5/64	.0781	DA18-0078	DA10-0078	DA20-0078
	3/32	.0937	DA18-0094	DA10-0094	DA20-0094
	7/64	.1094	DA18-0109	DA10-0109	DA20-0109
1/8		.1250	DA18-0125	DA10-0125	DA20-0125
	9/64	.1406	DA18-0141	DA10-0141	DA20-0141
	5/32	.1562	DA18-0156	DA10-0156	DA20-0156
	11/64	.1719	DA18-0172	DA10-0172	DA20-0172
3/16		.1875	DA18-0187	DA10-0187	DA20-0187
	13/64	.2031	DA18-0203	DA10-0203	DA20-0203
	7/32	.2188	DA18-0219	DA10-0219	DA20-0219
	15/64	.2344	DA18-0234	DA10-0234	DA20-0234
1/4		.2500	DA18-0250	DA10-0250	DA20-0250
	17/64	.2656	DA18-0266	DA10-0266	DA20-0266
	9/32	.2812	DA18-0281	DA10-0281	DA20-0281
	19/64	.2969	DA18-0297	DA10-0297	DA20-0297
5/16		.3125	DA18-0312	DA10-0312	DA20-0312
	21/64	.3281	DA18-0328	DA10-0328	DA20-0328
	11/32	.3438	DA18-0344	DA10-0344	DA20-0344
	23/64	.3594	DA18-0359	DA10-0359	DA20-0359
3/8		.3750	DA18-0375	DA10-0375	DA20-0375
	25/64	.3906	DA18-0391	DA10-0391	
	13/32	.4062	DA18-0406	DA10-0406	
	27/64	.4219	DA18-0422	DA10-0422	
7/16		.4375	DA18-0437	DA10-0437	
	29/64	.4531	DA18-0453	DA10-0453	
	15/32	.4688	DA18-0469	DA10-0469	
	31/64	.4844	DA18-0484	DA10-0484	
1/2		.5000	DA18-0500	DA10-0500	
	33/64	.5156	DA18-0516	DA10-0516	
	17/32	.4312	DA18-0531	DA10-0531	
	35/64	.5469	DA18-0547	DA10-0547	
9/16		.5625	DA18-0562	DA10-0562	
	37/64	.5781	DA18-0578		
	19/32	.5938	DA18-0594		
	39/64	.6094	DA18-0609		
5/8		.6250	DA18-0625		
	41/64	.6406	DA18-0641		
	21/32	.6562	DA18-0656		
	43/64	.6719	DA18-0672		
11/16		.6875	DA18-0688		
	45/64	.7031	DA18-0703		
	23/32	.7188	DA18-0719		
	47/64	.7344	DA18-0734		
3/4		.7500	DA18-0750		

COLLETS



COLLET SETS

- ⇒ Sets include wooden tray. Plastic Cases sold separately.
- ⇒ Special sets available upon request.



ER (SA) COLLET SETS—METRIC

PART NUMBER	COLLET STYLE	DESCRIPTION	RANGE	INCLUDES
SA8-MSET	ER8	ER8 X 9 PC SET	0.5-5.0MM	1.0-5.0MM BY INCREMENTS OF 0.5MM
SA11-MSET	ER11	ER11 X 13 PC SET	0.5-7.0MM	1.0-7.0MM BY INCREMENTS OF 0.5MM
SA16-MSET	ER16	ER16 X 10 PC SET	0.5-10.0MM	1.0-10.0MM BY INCREMENTS OF 1.0MM
SA20-MSET	ER20	ER20 X 12 PC SET	1.0-13.0MM	2.0-13.0MM BY INCREMENTS OF 1.0MM
SA25-MSET	ER25	ER25 X 15 PC SET	1.0-16.0MM	2.0-16.0MM BY INCREMENTS OF 1.0MM
SA32-MSET	ER32	ER32 X 18 PC SET	2.0-20.0MM	3.0-20.0MM BY INCREMENTS OF 1.0MM
SA40-MSET	ER40	ER40 X 23 PC SET	3.0-26.0MM	4.0-26.0MM BY INCREMENTS OF 1.0MM
SA50-MSET	ER50	ER50 X 17 PC SET	5.0-34.0MM	6.0-34.0MM BY INCREMENTS OF 2.0MM

ER (SA) COLLET SETS—INCH

PART NUMBER	COLLET STYLE	DESCRIPTION	RANGE	INCLUDES
SA11-ISET	ER11	ER11 X 7 PC SET	1/32-1/4	1/16-1/4 BY INCREMENTS OF 1/32
SA16-ISET	ER16	ER16 X 10 PC SET	1/16-3/8	3/32-3/8 BY INCREMENTS OF 1/32
SA20-ISET	ER20	ER20 X 12 PC SET	1/8-1/2	5/32-1/2 BY INCREMENTS OF 1/32
SA25-ISET	ER25	ER25 X 16 PC SET	1/8-5/8	5/32-5/8 BY INCREMENTS OF 1/32
SA32-ISET	ER32	ER32 X 18 PC SET	3/16-3/4	7/32-3/4 BY INCREMENTS OF 1/32
SA40-ISET	ER40	ER40 X 13 PC SET	1/8-1"	1/8-1" BY INCREMENTS OF 1/16

DA COLLET SETS

PART NUMBER	COLLET STYLE	DESCRIPTION	INCLUDES
DA18-SET9	DA-180	DA180 X 9 PC SET	1/4-3/4 BY INCREMENTS OF 1/16
DA18-SET17	DA-180	DA180 X 17 PC SET	1/4-3/4 BY INCREMENTS OF 1/32
DA18-SET21	DA-180	DA180 X 21 PC SET	1/8-3/4 BY INCREMENTS OF 1/32
DA18-SET33	DA-180	DA180 X 33 PC SET	1/4-3/4 BY INCREMENTS OF 1/64
DA18-SET41	DA-180	DA180 X 41 PC SET	1/8-3/4 BY INCREMENTS OF 1/64
DA10-SET8	DA-100	DA100 X 8 PC SET	1/8-9/16 BY INCREMENTS OF 1/16
DA10-SET15	DA-100	DA100 X 15 PC SET	1/8-9/16 BY INCREMENTS OF 1/32
DA10-SET21	DA-100	DA100 X 21 PC SET	1/4-9/16 BY INCREMENTS OF 1/64
DA10-SET29	DA-100	DA100 X 29 PC SET	1/8-9/16 BY INCREMENTS OF 1/64
DA10-SET33	DA-100	DA100 X 33 PC SET	1/16-9/16 BY INCREMENTS OF 1/64
DA20-SET9	DA-200	DA200 X 9 PC SET	1/8-3/8 BY INCREMENTS OF 1/32
DA20-SET17	DA-200	DA200 X 17 PC SET	1/8-3/8 BY INCREMENTS OF 1/64
DA20-SET21	DA-200	DA200 X 21 PC SET	1/16-3/8 BY INCREMENTS OF 1/64
DA30-SET7	DA-300	DA300 X 7 PC SET	1/16-1/4 BY INCREMENTS OF 1/32
DA30-SET14	DA-300	DA300 X 14 PC SET	3/64-1/4 BY INCREMENTS OF 1/64

TG COLLET SETS

PART NUMBER	COLLET STYLE	DESCRIPTION	INCLUDES
SG10-SET59	TG-100	TG100 X 59 PC SET	3/32-1" BY INCREMENTS OF 1/64
SG10-SET41	TG-100	TG100 X 41 PC SET	3/8-1" BY INCREMENTS OF 1/64
SG10-SET30	TG-100	TG100 X 30 PC SET	3/32-1" BY INCREMENTS OF 1/32
SG10-SET21	TG-100	TG100 X 21 PC SET	3/8-1" BY INCREMENTS OF 1/32
SG10-SET15	TG-100	TG100 X 15 PC SET	1/8-1" BY INCREMENTS OF 1/16
SG15-SET65	TG-150	TG150 X 65 PC SET	1/2-1 1/2 BY INCREMENTS OF 1/64
SG15-SET33	TG-150	TG150 X 33 PC SET	1/2-1 1/2 BY INCREMENTS OF 1/32
SG15-SET17	TG-150	TG150 X 17 PC SET	1/2-1 1/2 BY INCREMENTS OF 1/16

COLLETS



COLLET CHUCK LOCKING NUTS For SA and SG Collet Chucks

- ⇒ Standard nut supplied with each collet chuck.
- ⇒ Other styles and sizes available upon request.

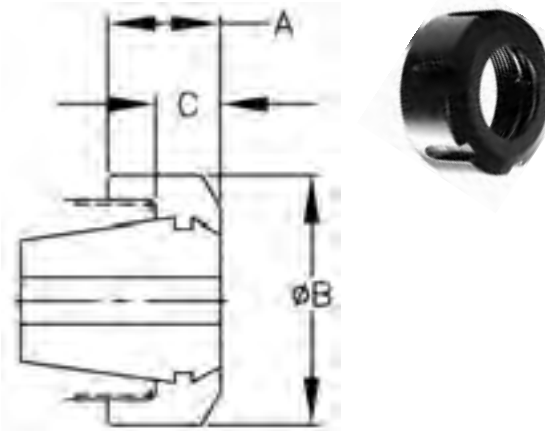

STANDARD COLLET NUT	COLLET SERIES	WRENCH TYPE	A	B	C	RECOMMENDED TORQUE FT LBS
SA11N	SA11	HEX	0.45	0.75	0.26	17
SA16N	SA16	HEX	0.69	1.10	0.42	45
SA20N	SA20	HEX	0.75	1.34	0.45	65
SA25N	SA25	SPANNER	0.79	1.65	0.47	80
SA32N	SA32	SPANNER	0.89	1.97	0.41	100
SA40N	SA40	SPANNER	1.00	2.48	0.59	120
SG10N	SG10	HEX	1.18	2.44	0.68	85
SG15N	SG15	SPANNER	1.75	3.25	0.68	85
DA20N	DA20	HEX	0.98	1.12	0.55	25
DA18N	DA18	HEX	0.86	1.63	0.62	45

COOLANT DISK LOCKING NUTS For SA Collet Chucks

- ⇒ Coolant Disk nuts rated for pressures up to 1500 P.S.I.
- ⇒ Other styles and sizes available upon request.
- ⇒ Coolant Disk Nuts require a coolant disk. Coolant disk are available in 0.5mm increments. See following page for part numbers and size availability.

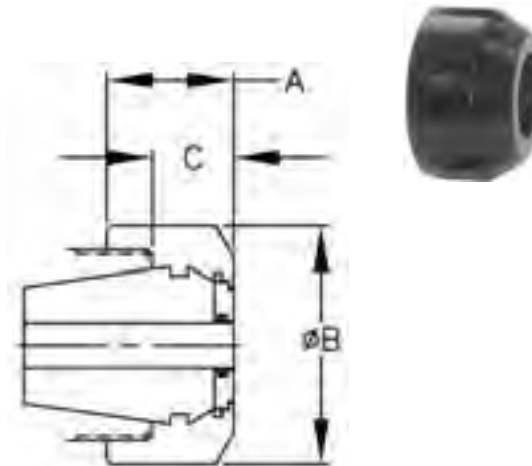

COOLANT DISK COLLET NUT	COLLET SERIES	WRENCH TYPE	A	B	C	RECOMMENDED TORQUE FT LBS
SA16NCD	SA16	HEX	0.89	1.10	0.61	45
SA20NCD	SA20	HEX	0.95	1.34	0.65	65
SA25NCD	SA25	SPANNER	0.98	1.65	0.67	80
SA32NCD	SA32	SPANNER	1.08	1.97	0.71	100
SA40NCD	SA40	SPANNER	1.20	2.48	0.79	120

COLLETS

DA COOLANT NUTS For DA Collet Chucks Only

- ⇒ Order by cutting tool shank size.
- ⇒ Coolant Disk is not removable.
- ⇒ Fits T.M. Smith DA Collet Chucks.
- ⇒ Recommended Torque:
DA20: 25 Ft lbs
DA18: 45 Ft lbs



COOLANT NUT BORE SIZE				DA20	DA18
FRACTIONAL		INCH	METRIC		
1/8		0.1182-0.1378	3.001-3.500	DA20N-C35	DA18N-C35
	5/32	0.1378-0.1575	3.501-4.000	DA20N-C40	DA18N-C40
		0.1575-0.1772	4.001-4.500	DA20N-C45	DA18N-C45
	3/16	0.1772-0.1968	4.501-5.000	DA20N-C50	DA18N-C50
		0.1969-0.2165	5.001-5.500	DA20N-C55	DA18N-C55
	7/32	0.2166-0.2362	5.501-6.000	DA20N-C60	DA18N-C60
1/4		0.2363-0.2559	6.001-6.500	DA20N-C65	DA18N-C65
		0.2559-0.2756	6.501-7.000	DA20N-C70	DA18N-C70
	9/32	0.2756-0.2953	7.001-7.500	DA20N-C75	DA18N-C75
	5/16	0.2953-0.3150	7.501-8.000	DA20N-C80	DA18N-C80
		0.3150-0.3346	8.001-8.500	DA20N-C85	DA18N-C85
	11/32	0.3347-0.3543	8.501-9.000	DA20N-C90	DA18N-C90
		0.3544-0.3740	9.001-9.500	DA20N-C95	DA18N-C95
3/8		0.3741-0.3937	9.501-10.000	DA20N-C100	DA18N-C100
	13/32	0.3937-0.4134	10.001-10.500		DA18N-C105
		0.4134-0.4331	10.501-11.000		DA18N-C110
	7/16	0.4331-0.4528	11.001-11.500		DA18N-C115
	15/32	0.4528-0.4724	11.501-12.000		DA18N-C120
		0.4725-0.4921	12.001-12.500		DA18N-C125
1/2		0.4922-0.5118	12.501-13.000		DA18N-C130
		0.5119-0.5315	13.001-13.500		DA18N-C135
	17/32	0.5315-0.5512	13.501-14.000		DA18N-C140
	9/16	0.5512-0.5709	14.001-14.500		DA18N-C145
		0.5709-0.5906	14.501-15.000		DA18N-C150
	19/32	0.5906-0.6102	15.001-15.500		DA18N-C155
5/8		0.6103-0.6299	15.501-16.000		DA18N-C160
		0.6300-0.6496	16.001-16.500		DA18N-C165
	21/32	0.6496-0.6693	16.501-17.000		DA18N-C170
	11/16	0.6693-0.6890	17.001-17.500		DA18N-C175
		0.6890-0.7087	17.501-18.000		DA18N-C180
	23/32	0.7087-0.7283	18.001-18.500		DA18N-C185
		0.7284-0.7480	18.501-19.000		DA18N-C190
3/4		0.7481-0.7677	19.001-19.500		DA18N-C195

COLLETS



COOLANT DISK For Coolant Thru Collet Nuts



- ⇒ Standard nut supplied with each collet chuck.
- ⇒ Coolant Disk nuts rated for pressures up to 1500 P.S.I.
- ⇒ Other styles and sizes available upon request.

COOLANT DISK BORE SIZE					SA16	SA20	SA25	SA32	SA40
FRACTIONAL		INCH	METRIC						
1/8		0.1182-0.1378	3.001-3.500	SA16CD-35	SA20CD-35	SA25CD-35	SA32CD-35	SA40CD-35	
	5/32	0.1378-0.1575	3.501-4.000	SA16CD-40	SA20CD-40	SA25CD-40	SA32CD-40	SA40CD-40	
		0.1575-0.1772	4.001-4.500	SA16CD-45	SA20CD-45	SA25CD-45	SA32CD-45	SA40CD-45	
	3/16	0.1772-0.1968	4.501-5.000	SA16CD-50	SA20CD-50	SA25CD-50	SA32CD-50	SA40CD-50	
		0.1969-0.2165	5.001-5.500	SA16CD-55	SA20CD-55	SA25CD-55	SA32CD-55	SA40CD-55	
	7/32	0.2166-0.2362	5.501-6.000	SA16CD-60	SA20CD-60	SA25CD-60	SA32CD-60	SA40CD-60	
1/4		0.2363-0.2559	6.001-6.500	SA16CD-65	SA20CD-65	SA25CD-65	SA32CD-65	SA40CD-65	
		0.2559-0.2756	6.501-7.000	SA16CD-70	SA20CD-70	SA25CD-70	SA32CD-70	SA40CD-70	
	9/32	0.2756-0.2953	7.001-7.500	SA16CD-75	SA20CD-75	SA25CD-75	SA32CD-75	SA40CD-75	
	5/16	0.2953-0.3150	7.501-8.000	SA16CD-80	SA20CD-80	SA25CD-80	SA32CD-80	SA40CD-80	
		0.3150-0.3346	8.001-8.500	SA16CD-85	SA20CD-85	SA25CD-85	SA32CD-85	SA40CD-85	
	11/32	0.3347-0.3543	8.501-9.000	SA16CD-90	SA20CD-90	SA25CD-90	SA32CD-90	SA40CD-90	
		0.3544-0.3740	9.001-9.500	SA16CD-95	SA20CD-95	SA25CD-95	SA32CD-95	SA40CD-95	
3/8		0.3741-0.3937	9.501-10.000	SA16CD-100	SA20CD-100	SA25CD-100	SA32CD-100	SA40CD-100	
	13/32	0.3937-0.4134	10.001-10.500		SA20CD-105	SA25CD-105	SA32CD-105	SA40CD-105	
		0.4134-0.4331	10.501-11.000		SA20CD-110	SA25CD-110	SA32CD-110	SA40CD-110	
	7/16	0.4331-0.4528	11.001-11.500		SA20CD-115	SA25CD-115	SA32CD-115	SA40CD-115	
	15/32	0.4528-0.4724	11.501-12.000		SA20CD-120	SA25CD-120	SA32CD-120	SA40CD-120	
		0.4725-0.4921	12.001-12.500		SA20CD-125	SA25CD-125	SA32CD-125	SA40CD-125	
1/2		0.4922-0.5118	12.501-13.000		SA20CD-130	SA25CD-130	SA32CD-130	SA40CD-130	
		0.5119-0.5315	13.001-13.500			SA25CD-135	SA32CD-135	SA40CD-135	
	17/32	0.5315-0.5512	13.501-14.000			SA25CD-140	SA32CD-140	SA40CD-140	
	9/16	0.5512-0.5709	14.001-14.500			SA25CD-145	SA32CD-145	SA40CD-145	
		0.5709-0.5906	14.501-15.000			SA25CD-150	SA32CD-150	SA40CD-150	
	19/32	0.5906-0.6102	15.001-15.500			SA25CD-155	SA32CD-155	SA40CD-155	
5/8		0.6103-0.6299	15.501-16.000			SA25CD-160	SA32CD-160	SA40CD-160	
		0.6300-0.6496	16.001-16.500				SA32CD-165	SA40CD-165	
	21/32	0.6496-0.6693	16.501-17.000				SA32CD-170	SA40CD-170	
	11/16	0.6693-0.6890	17.001-17.500				SA32CD-175	SA40CD-175	
		0.6890-0.7087	17.501-18.000				SA32CD-180	SA40CD-180	
	23/32	0.7087-0.7283	18.001-18.500				SA32CD-185	SA40CD-185	
		0.7284-0.7480	18.501-19.000				SA32CD-190	SA40CD-190	
3/4		0.7481-0.7677	19.001-19.500				SA32CD-195	SA40CD-195	
	25/32	0.7678-0.7874	19.501-20.000				SA32CD-200	SA40CD-200	
		0.7875-0.8070	20.001-20.500					SA40CD-205	
	13/16	0.8071-0.8267	20.501-21.000					SA40CD-210	
	27/32	0.8268-0.8464	21.001-21.500					SA40CD-215	
		0.8465-0.8661	21.501-22.000					SA40CD-220	
7/8		0.8662-0.8858	22.001-22.500					SA40CD-225	
		0.8859-0.9055	22.501-23.000					SA40CD-230	
	29/32	0.9056-0.9252	23.001-23.500					SA40CD-235	
	15/16	0.9253-0.9448	23.501-24.000					SA40CD-240	
		0.9449-0.9645	24.001-24.500					SA40CD-245	
	31/32	0.9646-0.9842	24.501-25.000					SA40CD-250	
1"		0.9843-1.0039	25.001-25.500					SA40CD-255	
		1.0040-1.0236	25.501-26.000					SA40CD-260	

The special machine drilling tools in this catalog will help you improve the productivity of your special machines and the quality of your products. With every T.M. Smith Tool product you get:

- Technology developed, tested and perfected.
- Technology selected and optimized for real world special machine drilling.
- Technology supported by the T.M. Smith service policy and nationwide network of trained stocking distributors.

There is no substitute for quality. That's why T.M. Smith tool is now the industry's leading comprehensive single-source supplier for all your quick change high speed spindle tooling systems

SPECIAL DESIGNS AVAILABLE TO SUIT YOUR APPLICATION!

⇒ Contact our engineering department with your specifications, samples or drawings. We have over 120 years combined manufacturing and engineering experience to serve you. You can email us at engineering@tmsmith.com or visit our web site at <http://www.tmsmith.com>.



QUICK-CHANGE DRILL HOLDING TOOLING TREE



Quick-Change Drill Holders Permit 5 Second Tool Change

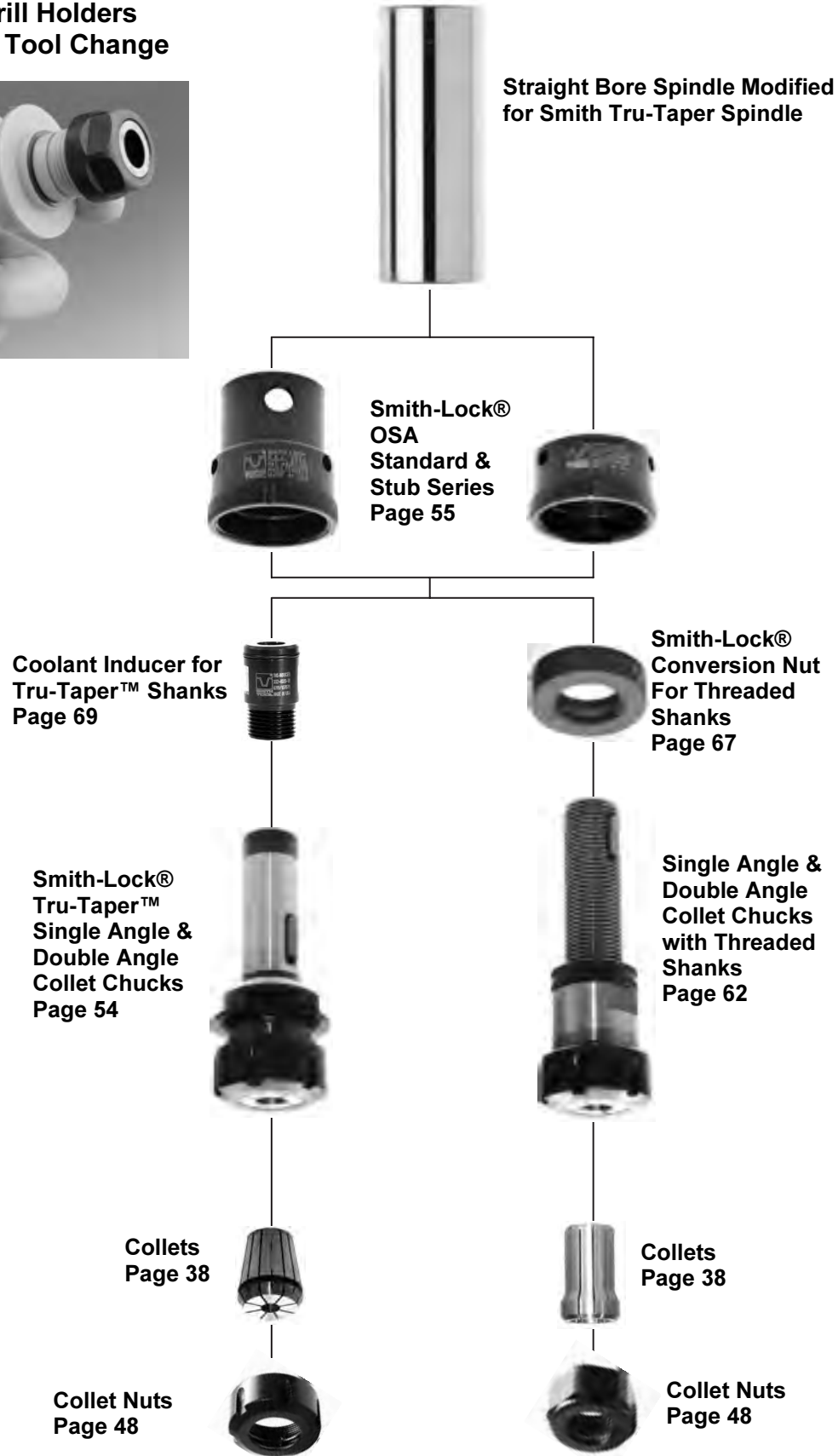



Smith Super Taper™ Spindle



Straight Bore Spindle Modified for Smith Tru-Taper® Spindle



Smith Super Taper™ OSA
Page 58



Ball-Lock™ OSA Standard & Stub Series
Page 57



Ball-Lock™ Conversion Nut For Threaded Shanks
Page 67



Coolant Inducer for Tru-Taper® Shanks
Page 69

Coolant Inducer for Tru-Taper® Shanks
Page 69



Smith Super Taper™ Single Angle Collet Chucks
Page 58

Ball-Lock™ Tru-Taper® Single Angle & Double Angle Collet Chucks
Page 54



Single Angle & Double Angle Collet Chucks with Threaded Shanks
Page 62



Collets
Page 38

Collets
Page 38



Collets
Page 38



Collet Nuts
Page 48

Collet Nuts
Page 48



Collet Nuts
Page 48

QUICK CHANGE DRILLING SYSTEMS



CCCH-TT Tru-Taper®, Smith-Lock® Single & Double Angle Collet Chucks



Features, Application, Ordering:

- ⇒ Accurate stub drilling holder.
- ⇒ Holder includes V-Drive preset screw—see page 66 for square drive preset screws.
- ⇒ Coolant Thru
 - See page 69 for rear coolant seal.
 - Must be used with Coolant Collet or Coolant Disk Nut
 - For Coolant Disk Nut add a “CD” to the part number—Single Angle Only!
- ⇒ Order Collets Separately, see page 38.
- ⇒ Optional rust resistant chrome finish, add “ST” to the part number.
- ⇒ Specials Available Upon Request.
- ⇒ Must be used with Smith-Lock® OSA, see page 55.
- ⇒ Add Q Suffix to designate MQL style

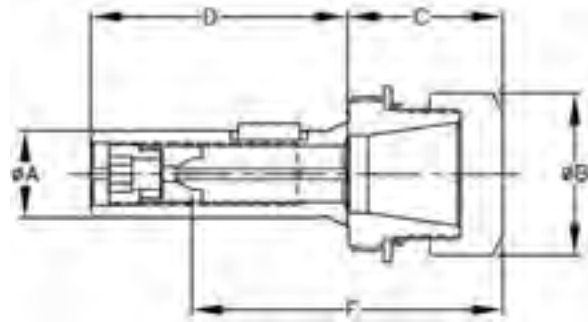

Note: Subtract .50 (12.7mm) from F Max. when coolant inducer is used.

Inch Shank

PART NUMBER	TOOL SIZE RANGE	COLLET SERIES	A	B	C	D	POSITIVE V-DRIVE DRILL DIA. RANGE	F MIN.	F MAX.	POSITIVE DRIVE #	REF. COOLANT INDUCER	TIGHTENING TORQUE FT/LBS	MAX. DIA. TOOL SHANK
801-712	.020-.393	SA16	3/4	1.10	1.94	2.47	.125-.375	1.51	3.26	107	331-4014-20	45	0.375
801-717			1-1/16			3.10		1.48	3.90		331-4016-20		
802-717	.080-.787	SA32	1-1/16	1.97	1.88	3.10	.250-.656	2.04	3.76	112	332-4016-18	100	0.669
802-722			1-3/8			4.10	.250-.750	2.11	4.76	114	332-4020-18		0.750
351-712*	.062-.375	DA20	3/4	1.12	1.84	2.47	.125-.375	1.65	3.17	107	331-4014-20	25	0.375
351-717*			1-1/16			3.10		1.67	3.81		331-4016-20		
352-717*	.062-.750	DA18	1-1/16	1.63	1.91	3.10	.250-.656	2.32	3.79	112	332-4016-18	45	0.669
352-722*			1-3/8			4.10	.250-.750	2.38	4.79	114	332-4020-18		0.750

Metric Shank

PART NUMBER	TOOL SIZE RANGE	COLLET SERIES	A	B	C	D	POSITIVE V-DRIVE DRILL DIA. RANGE	F MIN.	F MAX.	POSITIVE DRIVE #	REF. COOLANT INDUCER	TIGHTENING TORQUE FT/LBS	MAX. DIA. TOOL SHANK
821-720	.5-10.0	SA16	20MM	27.9	49.3	62.7	3.5-9.5	38.4	85.6	107	331-4014-20	45	9.5
821-728*			28MM			78.7		37.5	101.6		331-4016-20		
822-728	2.0-20.0	SA32	28MM	50.0	47.8	78.7	5.5-17.0	51.8	100.1	112	332-4016-18	100	17.0
822-736*			36MM			104.1	6.5-19.0	50.0	122.2	114	332-4020-18		19.1
361-720*	1.57-9.5	DA20	20MM	28.5	47.5	62.7	3.5-9.5	43.2	84.1	107	331-4014-20	25	9.5
361-728*			28MM			78.7		42.9	100.1		331-4016-20		
362-728*	1.57-19.05	DA18	28MM	46.0	45.0	78.7	5.5-17.0	56.9	97.3	112	332-4016-18	45	17.0
362-736*			36MM			104.1	6.5-19.0	57.0	124.5	114	332-4020-18		19.1

QUICK CHANGE DRILLING SYSTEMS



OSA Over Spindle Adapter, Smith-Lock® Standard Series



Features, Application, Ordering:

- ⇒ For use with Smith-Lock® tool holders, see page 54 and Smith-Lock® conversion nuts, see page 67.
- ⇒ Coolant Thru
 - Spindle must be manufactured to accept rear coolant seal.
- ⇒ Optional rust resistant chrome finish, add "ST" to the part number.
- ⇒ Note: It is recommended to tighten lock screws in applications where:
 - Excessive inertia is present due to fast spindle starts/stops.
 - Excessive chatter is present.
 - Interrupted cuts occur.

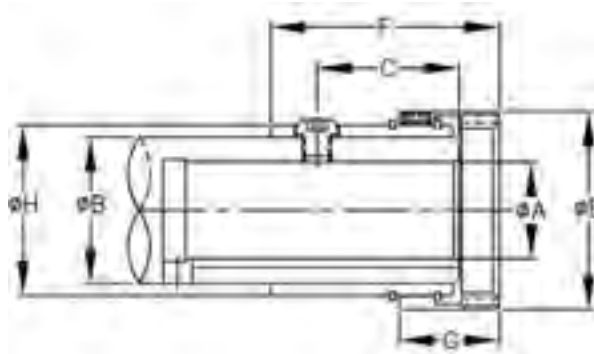

PART NUMBER	A TOOL SIZE ACME	B SPINDLE +.000 -.002	C +.000 -.005	E MAX.	F TOTAL LENGTH	G	H BODY	MOUNTING SCREW SIZE	REF. SMITH-LOCK CONVERSION NUT NO.
3712	3/4-12	1.235	1.250	1.76	2.26	1.102	1.50	5/16-24	3812
3717	1-1/16-12	1.610	1.562	2.18	2.51		1.87		3817
3722	1-3/8-12	1.985	1.812	2.56	3.01		2.25		3822
3730-FT	1-7/8-12	2.610	2.312	3.20	3.25		2.86		3830-FT

OSA Over Spindle Adapter, Smith-Lock® Stub Series



Features, Application, Ordering:

- ⇒ For use with Smith-Lock® tool holders, see page 54 and Smith-Lock® conversion nuts, see page 67.
- ⇒ Coolant Thru
 - Spindle must be manufactured to accept rear coolant seal.
- ⇒ Optional rust resistant chrome finish, add "ST" to the part number.
- ⇒ Note: It is recommended to tighten lock screws in applications where:
 - Excessive inertia is present due to fast spindle starts/stops.
 - Excessive chatter is present
 - Interrupted cuts occur.
 - Add -FT for Full Thread

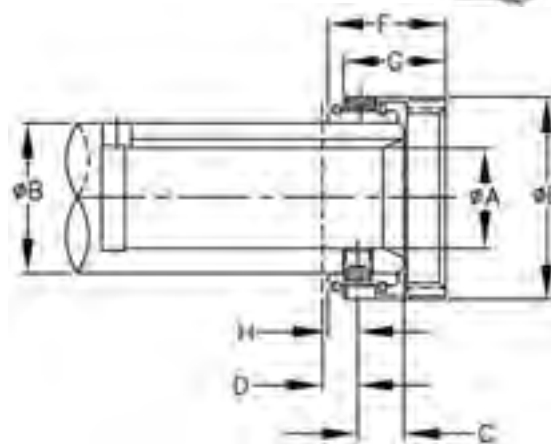

INCH PART NUMBER	A TOOL SIZE ACME (INCH)	B SPINDLE +.000 -.002	C +.000 -.005	D MIN. STEP-UP +/- .010	E MAX.	F TOTAL LENGTH	G	H +/- .005	MOUNTING SCREW SIZE	REF. SMITH-LOCK CONVERSION NUT NO.
3712-SS	3/4-12	1.235	.500	.38	1.76	1.26	1.102	.320	5/16-24	3812
3717-SS	1-1/16-12	1.610			2.18					3817
3722-SS	1-3/8-12	1.985			2.56					3822
METRIC PART NUMBER	A TOOL SIZE TRAP. (METRIC)	B SPINDLE +.00 -.05	C +.00 -.13	D MIN. STEP-UP +/- .25	E MAX.	F TOTAL LENGTH	G	H +/- .13	MOUNTING SCREW SIZE	REF. SMITH-LOCK CONVERSION NUT NO.
3920-SS*	TR20	31.37	12.70	9.65	44.20	32.0	28.0	8.13	M8 X 1.0mm	4020
3928-SS	TR28	40.89			55.37					4028
3936-SS*	TR36	50.42			65.02					4036

QUICK CHANGE DRILLING SYSTEMS



CCCH-TT Tru-Taper®, Ball-Lock™ Single & Double Angle Collet Chucks



Features, Application, Ordering:

- ⇒ Accurate stub drilling holder.
- ⇒ Holder includes V-Drive preset screw—see page 66 for square drive preset screws.
- ⇒ Coolant Thru
 - See page 69 for rear coolant seal.
 - Must be used with Coolant Collet or Coolant Disk Nut.
 - For Coolant Disk Nut add a “CD” to the part number—Single Angle Only!
- ⇒ Order Collets Separately, see page 38.
- ⇒ Optional rust resistant chrome finish, add “ST” to the part number.
- ⇒ Specials Available Upon Request.
- ⇒ Must be used with Ball-Lock™ OSA, see page 57.
- ⇒ Add Q Suffix to designate MQL style

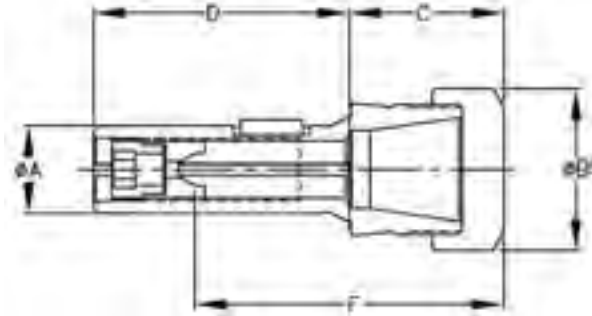

Note: Subtract .50 (12.7mm) from F Max. when coolant inducer is used.

Inch Shank

PART NUMBER	TOOL SIZE RANGE	COLLET SERIES	A	B	C	D	POSITIVE V-DRIVE DRILL DIA. RANGE	F MIN.	F MAX.	POSITIVE DRIVE #	REF. COOLANT INDUCER	TIGHTENING TORQUE FT/LBS	MAX. DIA. TOOL SHANK	
811-710	.020-.393	SA16	5/8	1.10	1.94	2.47	.125-.375	1.51	3.27	107	331-4013-20	45	.375	
811-712			3/4											331-4014-20
811-717			1-1/16											331-4016-20
812-717	.080-.787	SA32	1-1/16	1.97	1.88	3.10	250-.656	2.04	3.75	112	332-4016-18	100	.669	
812-722			1-3/8											4.10
331-712*	.062-.375	DA20	3/4	1.12	1.84	2.47	.125-.375	1.65	3.17	107	331-4014-20	25	.375	
331-717			1-1/16											3.10
332-717	.062-.750	DA18	1-1/16	1.63	1.91	3.10	250-.656	2.32	3.79	112	332-4016-18	45	.669	
332-722			1-3/8											4.10

Metric Shank

PART NUMBER	TOOL SIZE RANGE	COLLET SERIES	A	B	C	D	POSITIVE V-DRIVE DRILL DIA. RANGE	F MIN.	F MAX.	POSITIVE DRIVE #	REF. COOLANT INDUCER	TIGHTENING TORQUE FT/LBS	MAX. DIA. TOOL SHANK
831-720	.5-10	SA16	20MM	27.9	49.3	62.7	3.5-9.5	38.4	85.6	107	331-4014-20	45	9.5
831-728*			28MM			78.7		37.5	101.6				
832-728	2.0-20.0	SA32	28MM	50.0	47.8	78.7	5.5-17.0	51.8	100.1	112	332-4016-18	100	17.0
832-736*			36MM			104.1							
341-720*	1.57-9.5	DA20	20MM	28.5	47.5	62.7	3.5-9.5	43.2	84.1	107	331-4014-20	25	9.5
341-728*			28MM			78.7							
342-728*	1.57-19.05	DA18	28MM	46.0	45.0	78.7	5.5-17.0	56.9	97.3	112	332-4016-18	45	17.0
342-736*			36MM			104.1							

QUICK CHANGE DRILLING SYSTEMS



OSA Over Spindle Adapter, Ball Lock™ Standard Series



Features, Application, Ordering:

- ⇒ For use with Ball-Lock™ tool holders, see page 56 and Ball-Lock™ conversion nuts, see page 67.
- ⇒ Coolant Thru
 - Spindle must be manufactured to accept rear coolant seal.
- ⇒ Optional rust resistant chrome finish, add "ST" to the part number.

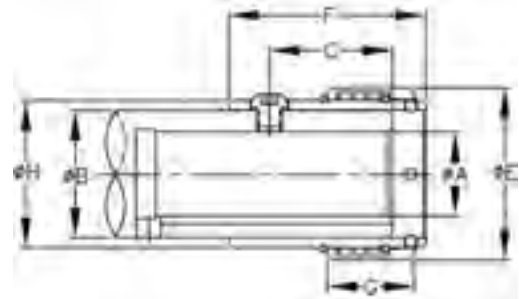

PART NUMBER	A TOOL SIZE ACME	B SPINDLE +.000 -.002	C +.000 -.005	E MAX.	F TOTAL LENGTH	G	H BODY	MOUNTING SCREW SIZE	REF. SMITH-LOCK CONVERSION NUT NO.
3010	5/8-16	.985	1.250	1.48	2.25	1.105	1.24	5/16-24	3110
3012	3/4-12	1.235	1.250	1.76	2.25		1.49		3112
3014	7/8-12	1.360	1.562	1.95	2.50		1.61		3114
3017	1-1/16-12	1.610	1.562	2.18	2.50		1.86		3117
3022	1-3/8-12	1.985	1.812	2.63	3.00		2.24		3122
3030	1-7/8-12	2.610	2.312	3.18	3.25		2.86		3130

OSA Over Spindle Adapter, Ball Lock™ Stub Series



Features, Application, Ordering:

- ⇒ For use with Ball-Lock™ tool holders, see page 56 and Ball-Lock™ conversion nuts, see page 67.
- ⇒ Coolant Thru
 - Spindle must be manufactured to accept rear coolant seal.
- ⇒ Optional rust resistant chrome finish, add "ST" to the part number.

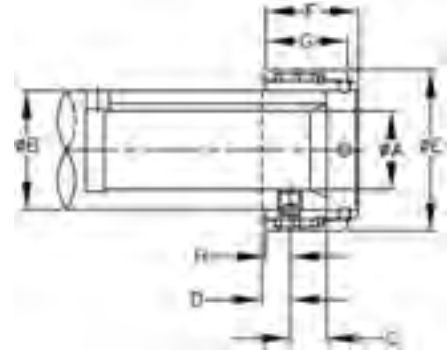

INCH PART NUMBER	A TOOL SIZE ACME (INCH)	B SPINDLE +.000 -.002	C +.000 -.005	D MIN. STEP-UP +/- .010	E MAX.	F TOTAL LENGTH	G	H +/- .005	MOUNTING SCREW SIZE	REF. SMITH-LOCK CONVERSION NUT NO.
3010-SS	5/8-16	.985	.500	.38	1.48	1.25	1.105	.320	5/16-24	3810
3012-SS	3/4-12	1.235			1.76					3812
3014-SS	7/8-12	1.360			1.89					3814
3017-SS	1-1/16-12	1.610			2.18					3817
3022-SS	1-3/8-12	1.985			2.63					3822

METRIC PART NUMBER	A TOOL SIZE TRAP. (METRIC)	B SPINDLE +.00 -.05	C +.00 -.13	D MIN. STEP-UP +/- .25	E MAX.	F TOTAL LENGTH	G	H +/- .13	MOUNTING SCREW SIZE	REF. SMITH-LOCK CONVERSION NUT NO.
3220-SS	TR20	31.37	12.70	9.65	44.7	32.0	28.1	8.13	M8 X 1.0mm	3320
3228-SS	TR28	40.89			55.4					3328
3236-SS	TR36	50.42			66.7					3336

QUICK CHANGE DRILLING SYSTEMS



SST™ Smith Super Taper™, Smith-Lock® Single Angle Collet Chucks



Features, Application, Ordering:

- ⇒ Accurate stub drilling holder.
- ⇒ Coolant Thru
 - See page 69 for rear coolant seal.
 - Must be used with Coolant Collet or Coolant Disk Nut.
 - For Coolant Disk Nut add a "CD" to the part number—Single Angle Only!
- ⇒ Order Collets Separately, see page 38.
- ⇒ Optional rust resistant chrome finish, add "ST" to the part number.
- ⇒ Specials Available Upon Request.
- ⇒ Must be used with Smith Super Taper™ OSA (see below).
- ⇒ Add Q Suffix to designate MQL style

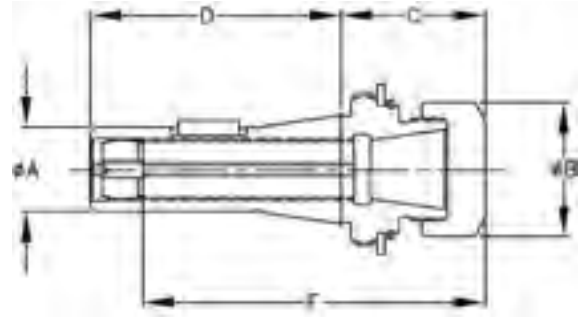

Note: Subtract .50 (12.7mm) from F Max. when coolant inducer is used.

PART NUMBER	TOOL SIZE RANGE	COLLET SERIES	A	B	C	D	COLLET NUT	F MIN.	F MAX.	POSITIVE DRIVE #	REF. COOLANT INDUCER	TIGHTENING TORQUE FT/LBS	MAX. DIA. TOOL SHANK
825-712	.040-.629	SA25	3/4	1.65	1.78	2.47	SA25N	1.56	3.03	PS07C	331-4014-20	50	0.375
825-717	.040-.629	SA25	1-1/16			3.10			4.23	PS12C	332-4016-18		0.629

OSA Over Spindle Adapter, Smith Super Taper™



Features, Application, Ordering:

- ⇒ For use with Smith Super Taper™ tool holders (see above).
- ⇒ Coolant Thru
 - Spindle must be manufactured to accept rear coolant seal.
- ⇒ Optional rust resistant chrome finish, add "ST" to the part number.
- ⇒ Note: It is recommended to tighten lock screws in applications where:
 - Excessive inertia is present due to fast spindle starts/stops.
 - Excessive chatter is present.
 - Interrupted cuts occur.

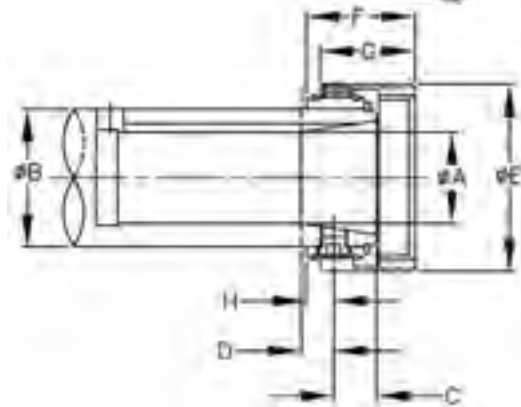

INCH PART NUMBER	A TOOL SIZE	B SPINDLE +.000 -.002	C +.000 -.005	D MIN. STEP-UP +/- .010	E MAX.	F TOTAL LENGTH	G	H +/- .005	MOUNTING SCREW SIZE	REF. SNAP RING
3712-SST	3/4	1.235	.500	.38	1.77	1.26	1.102	.320	5/16-24	3012-6SST
3717-SST	1-1/16	1.610			2.19					3017-6SST



**Smith Tru-Taper®
Spindle**

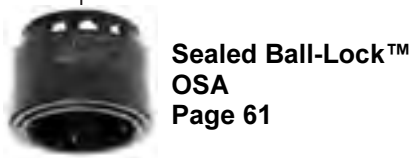

**Sealed Ball-Lock™
OSA
Page 61**



**Coolant Inducer for
Tru-Taper Shanks
Page 69**



**Sealed Ball-Lock™
Collet Chucks
Page 60**



**Single Angle
Collets
Page 38**



**Collet Nuts
Page 48**

Sealed Ball Lock (SBL)

One of the most common problems in production today is keeping the spindle and locking systems clean. Materials like aluminum and cast iron have fine chips that make their way into most front locking systems. Sealed Ball-Lock™ was designed to help eliminate these problems.

Sealed Ball-Lock™ uses a series of seals that make contact with the outer locking shell and the outer diameter of the tool holder. These seals in concert with a coolant disk collet nut seal the holder system from external contamination.



Contact seals to prevent corruption from entering the OSA & spindle bore.

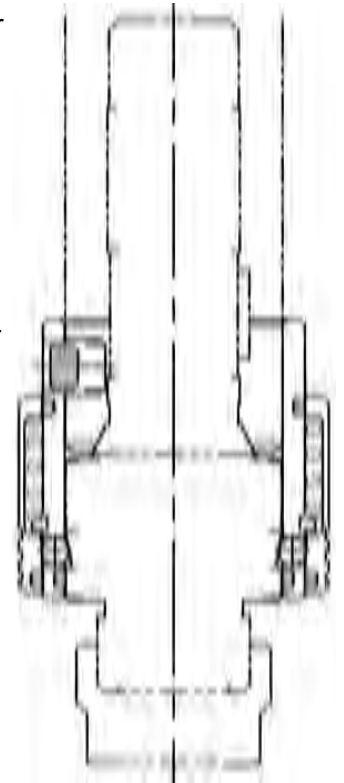

Available in standard Tru-Taper® Automotive & Metric spindle configurations, Sealed Ball-Lock™ is your best defense against chips & coolant.

See the following pages for ordering & technical information.

Specials available upon request.



QUICK CHANGE DRILLING SYSTEMS



SBL Tru-Taper®, Sealed Ball-Lock™ Single Angle Collet Chucks



Features, Application, Ordering:

- ⇒ Accurate stub drilling holder.
- ⇒ Holder includes V-Drive preset screw—see page 66 for square drive preset screws.
- ⇒ Coolant Thru
 - See page 102 for rear coolant seal.
 - Must be used with Coolant Collet or Coolant Disk Nut.
 - For Coolant Disk Nut add a “CD” to the part number—Single Angle Only!
- ⇒ Order Collets Separately, see page 38.
- ⇒ Optional rust resistant chrome finish, add “ST” to the part number.
- ⇒ Specials Available Upon Request.
- ⇒ Must be used with Sealed Ball-Lock™ OSA, see page 61.
- ⇒ Add Q Suffix to designate MQL style

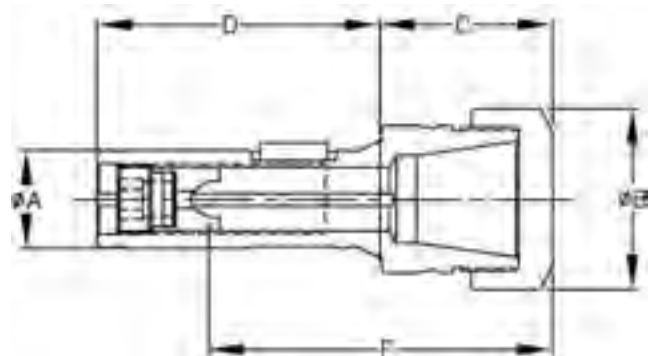

Note: Subtract .50 (12.7mm) from F Max. when coolant inducer is used.

Inch Shank

PART NUMBER	TOOL SIZE RANGE	COLLET SERIES	A	B	C	D	POSITIVE V-DRIVE DRILL DIA. RANGE	F MIN.	F MAX.	POSITIVE DRIVE #	REF. COOLANT INDUCER	TIGHTENING TORQUE FT/LBS	MAX. DIA. TOOL SHANK
881-710*	.020-.276	SA11	5/8	.63	1.49	2.47	.093-.250	.98	2.92	PS05V	331-4013-SA11	17	.250
882-710*	.020-.393	SA16	5/8	1.10	1.73	2.47	.125-.375	1.38	2.70	107	331-4014-SA11	35	.375
882-712	.020-.393	SA16	3/4	1.10	1.73	2.47	.125-.375	1.38	3.06	107	331-4014-20	45	.375
883-712*	.040-.511	SA20	3/4	1.34	1.78	2.47	.125-.500	1.50	2.24	PS09V	331-4014-20	65	.500
883-714*	.040-.511	SA20	7/8	1.34	1.78	2.97	.125-.500	1.50	3.49	109	331-4014-SA20	65	.500
882-717*	.020-.393	SA16	1-1/16	1.10	1.73	3.10	.125-.375	1.38	3.06	107	311-4016-20	45	.375
885-717	.080-.787	SA32	1-1/16	1.97	1.94	3.10	.250-.656	1.98	3.80	112	332-4016-18	100	.669
885-722*	.080-.787	SA32	1-3/8	1.97	1.94	4.10	.250-.750	1.98	4.80	114	332-4020-18	100	.750
886-722	.120-1.024	SA40	1-3/8	2.48	2.23	4.10	.250-.875	2.09	4.63	117	332-4020-SA40	120	1.000

Metric Shank

PART NUMBER	TOOL SIZE RANGE	COLLET SERIES	A	B	C	D	POSITIVE V-DRIVE DRILL DIA. RANGE	F MIN.	F MAX.	POSITIVE DRIVE #	REF. COOLANT INDUCER	TIGHTENING TORQUE FT/LBS	MAX. DIA. TOOL SHANK
882-720	.5-10.0	SA16	20MM	27.9	44.0	62.7	3.5-9.5	35	77	107	331-4014-20	45	9.5
883-720*	1.0-13.0	SA20	20MM	34.1	45.2	62.7		38	56	PS09V	331-4014-20	65	12.7
882-728*	.5-10.0	SA16	28MM	27.9	44.0	78.7		35	77	107	331-4016-20	45	9.5
885-728	2.0-20.0	SA32	28MM	50.0	49.3	78.7	5.5-17.0	51	96	112	332-4016-18	100	17.0
885-736*			36MM				104.1	6.5-19.0	51	121	114		332-4020-18
886-736	3.5-26.0	SA40	36MM	63.0	56.6	104.1	6.5-22.5	53	118	117	332-4020-SA40	120	25.4

QUICK CHANGE DRILLING SYSTEMS



OSA Over Spindle Adapter, Sealed Ball-Lock™ Stub Series



Features, Application, Ordering:

- ⇒ For use with Sealed Ball-Lock™ tool holders, see page 60 and Sealed Ball-Lock™ conversion nuts, see page 68.
- ⇒ Coolant Thru
 - Spindle must be manufactured to accept rear coolant seal.
- ⇒ Optional rust resistant chrome finish, add "ST" to the part number.

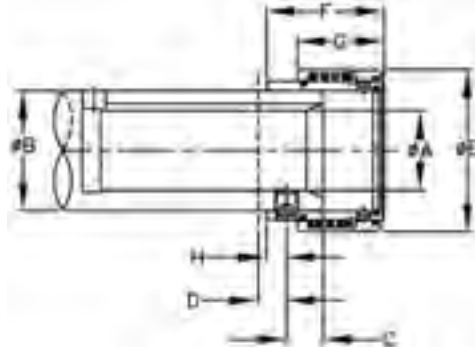

INCH PART NUMBER	A TOOL SIZE ACME (INCH)	B SPINDLE +.000 -.002	C +.000 -.005	D MIN. STEP-UP +/- .010	E MAX.	F TOTAL LENGTH	G	H	MOUNTING SCREW SIZE
88010-SS	5/8-16	.985	.500	.38	1.48	1.59	1.17	.28	5/16-24
88012-SS	3/4-12	1.235			1.76				
88014-SS	7/8-12	1.360			1.89				
88017-SS	1-1/16-12	1.610			2.18				
88022-SS	1-3/8-12	1.985			2.56				
METRIC PART NUMBER	A TOOL SIZE TRAP. (METRIC)	B SPINDLE +.00 -.05	C +.00 -.13	D MIN. STEP-UP +/- .25	E MAX.	F TOTAL LENGTH	G	H	MOUNTING SCREW SIZE
88020-SS	TR20	31.37	12.7	9.65	44.7	40.5	29.8	7.1	M8 X 1.0mm
88028-SS	TR28	40.89			55.4				
88036-SS	TR36	50.42			66.7				

OSA Over Spindle Adapter, Sealed Ball-Lock™ Standard ASA Spindle Series



Features, Application, Ordering:

- ⇒ For use with Sealed Ball-Lock™ tool holders, see page 60 and Sealed Ball-Lock™ conversion nuts, see page 68.
- ⇒ Coolant Thru
 - Spindle must be manufactured to accept rear coolant seal.
- ⇒ Optional rust resistant chrome finish, add "ST" to the part number.

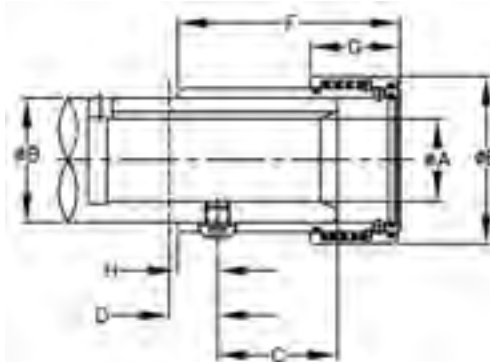

INCH PART NUMBER	A TOOL SIZE ACME (INCH)	B SPINDLE +.000 -.002	C +.000 -.005	D MIN. STEP-UP +/- .010	E MAX.	F TOTAL LENGTH	G	H	MOUNTING SCREW SIZE
88010*	5/8-16	.985	1.250	.38	1.48	2.32	1.17	.33	5/16-24
88012	3/4-12	1.235	1.250		1.76	2.32		.27	
88014*	7/8-12	1.360	1.562		1.89	2.65		.27	
88017	1-1/16-12	1.610	1.562		2.18	2.89		.27	
88022	1-3/8-12	1.985	1.812		2.56	3.07		.27	

QUICK CHANGE DRILLING SYSTEMS



CTDH ACME THREADED SHANK Single & Double Angle Collet Chucks

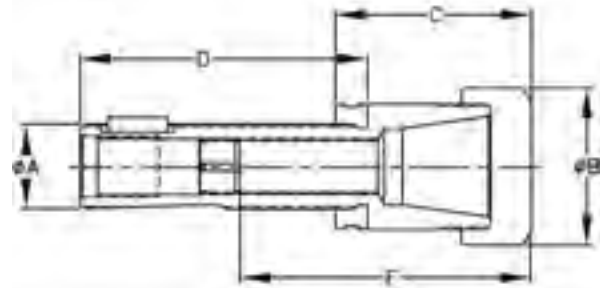

Features, Application, Ordering:

- ⇒ Accurate stub drilling holder.
- ⇒ Coolant Thru
 - See page 69 for rear coolant seal.
 - Must be used with Coolant Collet or Coolant Disk Nut.
 - For Coolant Disk Nut add a "CD" to the part number—Single Angle Only!
- ⇒ Order Collets Separately, see page 38.
- ⇒ Optional rust resistant chrome finish, add "ST" to the part number.
- ⇒ Specials Available Upon Request.
- ⇒ Add Q Suffix to designate MQL style

PART NUMBER	TOOL SIZE RANGE	COLLET SERIES	A ACME SHANK	B	C	D	F MIN.	F MAX.	NUT HEX	PRESET SCREW	MAX DIA TOOL SHANK	N COLLET NUT	TIGHTENING TORQUE FT/LBS
104-210	.020-.375	SA16	5/8-16	1.10	1.60	3.00	1.28	2.56	25mm	PS05C	0.25	SA16N	45
104-212			3/4-12			3.00		3.25		PS07C	0.38		
104-214*			7/8-12			3.62		3.42		PS07C	0.38		
105-214*	.020-.500	SA20	7/8-12	1.30	1.80	3.62	1.50	3.26	30mm	PS08C	0.44	SA20N	65
105-217			1-1/16-12			3.62		3.26		PC09C	0.50		
107-217	.098-.750	SA32	1-1/16-12	2.00	2.50	3.62	1.85	3.42		PS12C	0.63	SA32N	100
107-222*			1-3/8-12			4.62		PS13C		0.75			
108-222	.098-1.000	SA40	1-3/8-12	2.50	2.70	4.62	2.13	4.89		PS13C	0.75	SA40N	120
108-230*			1-7/8-12			5.62		5.57		PS18C	1.00		
101-212	.062-.375	DA20	3/4-12	1.15	1.81	3.00	1.68	2.79	1.00	107	.38	DA20N	25
101-214			7/8-12		1.82	3.62		3.39					
101-217			1-1/16-12		1.84	3.62		1.77					
102-217	.062-.750	DA18	1-1/16-12	1.72	2.12	3.62	2.37	3.50	1.50	112	.67	DA18N	45
102-222			1-3/8		2.03	4.62	2.38	4.43		114	.75		

SHORT EXTRACTION QUICK CHANGE COLLET HOLDERS



Single Angle Collet Chucks

Features, Application, Ordering:

- ⇒ Uses Proven Stub Type Smith Lock Quick Change
- ⇒ Shank Mounting of Customer's Choice
- ⇒ Collets to be Ordered Separately
- ⇒ Available with High Pressure Sealed Coolant Capability
- ⇒ Tool Change only requires 1" [25.4m] for Extraction
- ⇒ Smith Lock Provides Easy Mechanical Leveraged Extraction

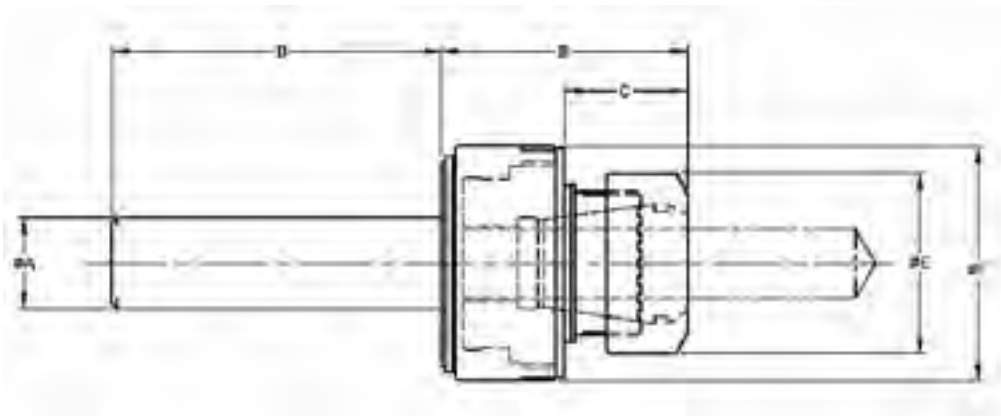
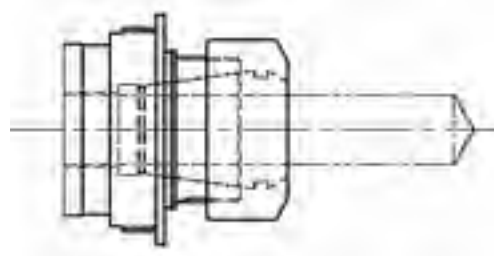

PART NUMBER	A	B	C	D	E	F	COLLET SERIES	COLLET RANGE
801SHRTEXT716	1.0000	2.46	1.13	3.60	1.10	2.18	ER16	.02-.39
801SHRTEXT720	1.2500			4.60				
801SHRTEXT724	1.5000			4.60				
802SHRTEXT716	1.0000	2.56	1.22	3.60	1.97	2.56	ER32	.08-.79
802SHRTEXT720	1.2500			4.60				
802SHRTEXT724	1.5000			4.60				

QUICK CHANGE DRILLING SYSTEMS



Change Drills, Drill Sizes on your lathe in just 5 seconds!

T.M. Smith Quick-Change low cost drill holding system slashes down time, improves accuracy and tool life. Now you can change drills or drill sizes in just 5 seconds. Drill lengths can be preset on the bench while your machine is running.

This production proven system consists of a Quick-Change sleeve adapter that fits into straight bore tool holders on your turret. The Quick-Change adapter accepts T.M. Smith Tru-Taper® Drill Holders and Smith-Lock® Quick-Change Conversion Adapter Nuts for standard Acme (automotive) shanks.



T.M. Smith's Quick-Change Drilling System can be installed in any straight bore lathe tool holder.



The Quick-Change Sleeve Adapter is inserted in the lathe tool holder and locked in place.



The Quick-Change Sleeve Adapter accepts T.M. Smith Tru-Taper® Drill Holders and Smith-Lock Conversion Adapter Nuts.



Insert the tool holder into the Adapter Sleeve.



Rotate the Smith-Lock® Quick-Change nut in a counter-clockwise direction.

QUICK CHANGE DRILLING SYSTEMS



QCSA Quick Change Sleeve Adapter



Features, Application, Ordering:

- ⇒ Designed for CNC Lathes and Screw Machines.
- ⇒ Easily installed into straight bore tool blocks.
- ⇒ Preset tooling off line for reduced down time.
- ⇒ Order Adapters Separately.
- ⇒ Optional rust resistant chrome finish, add "ST" to the part number.
- ⇒ Specials Available Upon Request.

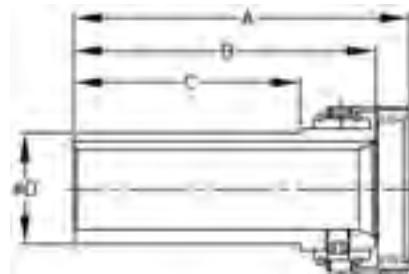

PART NUMBER	ADAPTER SIZE	ADAPTER TYPE	A	B	C	D	REFERENCE OSA
STB-0019	3/4	SMITH-LOCK®	4.44	4.00	3.00	1.500	3712-SS
STB-0020	1-1/16		4.44	4.00	3.00	1.500	3717-SS
STB-0021*	1-3/8		4.94	4.50	3.50	2.000	3722-SS
STB-0019-BL*	3/4	BALL-LOCK™	4.42	4.00	3.00	1.500	3012-SS
STB-0020-BL*	1-1/16		4.42	4.00	3.00	1.500	3017-SS
STB-0021-BL*	1-3/8		4.92	4.50	3.50	2.000	3022-SS
STB-0019-SBL*	3/4	SEALED BALL-LOCK™	4.81	4.00	3.00	1.500	88012-SS
STB-0020-SBL*	1-1/16		4.81	4.00	3.00	1.500	88017-SS
STB-0021-SBL*	1-3/8		5.31	4.50	3.50	2.000	88022-SS

Drill Holder Preset Adapters

Features, Application, Ordering:

- ⇒ For use with any Presetter with Cat 50 ANSI B5.50 spindle.
- ⇒ Optional OSA, order stub series OSA separately.
- ⇒ Specials available upon request.

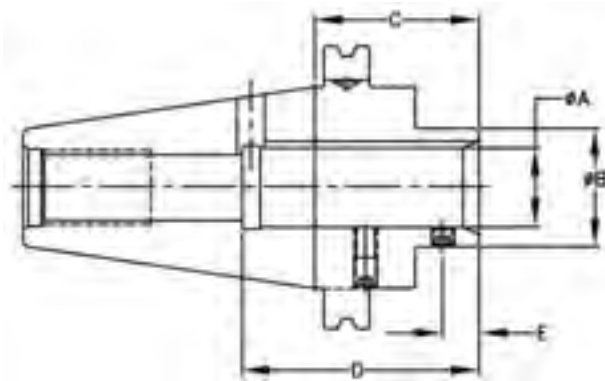

PART NUMBER	ADAPTER SIZE	ADAPTER TYPE	A	B	C	D	E
C50-710-TT*	5/8	STANDARD ACME OR TRU-TAPER®	.6250	.985	2.26	2.62	.500
C50-712-TT*	3/4		.7500	1.235	2.26	2.62	
C50-714-TT*	7/8		.8750	1.358	2.26	3.25	
C50-717-TT*	1-1/16		1.0625	1.610	2.26	3.25	
C50-722-TT*	1-3/8		1.3750	1.985	3.00	4.25	
C50-720-TT*	20MM		20.000	31.37MM	57.4MM	66.5MM	12.7MM
C50-728-TT*	28MM		28.000	40.89MM	57.4MM	82.6MM	
C50-736-TT*	36MM	36.000	50.42MM	76.2MM	108.0MM		
C50-712-ST*	3/4	SMITH SUPER-TAPER™ ONLY	.7500	1.235	2.26	2.62	.500
C50-717-ST*	1-1/16		1.0625	1.610	2.26	3.25	

QUICK CHANGE DRILLING SYSTEMS



POSITIVE DRIVES FOR COLLET CHUCKS

Features, Application, Ordering:

- ⇒ Provide positive tool drive and length preset capability in collet style drill holders.
- ⇒ "V" Style covers a variety of tang widths where square drives are dedicated to the tang of the cutting tool.
- ⇒ Specials available upon request.

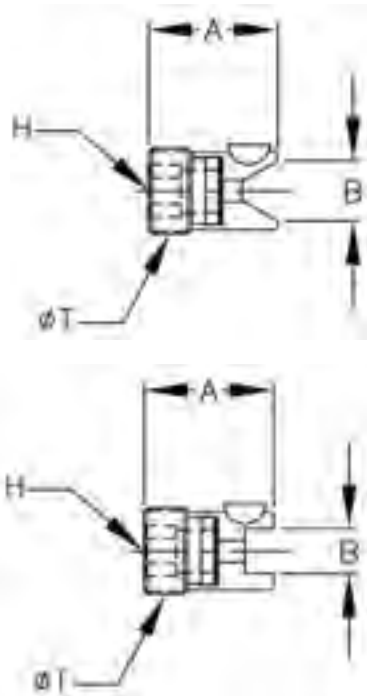

PART NUMBER	A	B	H	T	DRIVE KEY
105	.78	V-DRIVE .094-.162	5/32 HEX	5/16-24 LH	202
105-094		.094			
105-122		.122			
105-162		.162			
107	1.00	V-DRIVE .094-.203	7/32 HEX	7/16-20 LH	202
107-094		.094			
107-122		.122			
107-162		.162			
107-203		.203			
109	1.08	V-DRIVE .094-.373	SCREW DRIVER SLOT	9/16-18 LH	213
109-094		.094			
109-122		.122			
109-162		.162			
109-203		.203			
109-243		.243			
109-303		.303			
109-373	.373				
112	1.13	V-DRIVE .162-.443	3/8 HEX	3/4-16 LH	213
112-162		.162			
112-203		.203			
112-243		.243			
112-303		.303			
112-373		.373			
112-443	.443				
114	1.13	V-DRIVE .162-.443	3/8 HEX	7/8-14 LH	213
114-162		.162			
114-203		.203			
114-243		.243			
114-303		.303			
114-373		.373			
114-443	.443				
117	1.56	V-DRIVE .122-.780	SCREW DRIVER SLOT	1-1/16-16 LH	605
117-122		.122			
117-162		.162			
117-203		.203			
117-243		.243			
117-303		.303			
117-373		.373			
117-443		.443			
117-514	.514				

QUICK CHANGE DRILLING SYSTEMS



QUICK CHANGE CONVERSION NUT Smith-Lock® for Acme & Metric Shanks



Features, Application, Ordering:

- ⇒ Must be used with Smith-Lock® Over Spindle Adapters, see page 55.
- ⇒ Conversion nuts allow you to use your existing Acme shank tool holders and gain the advantage of 5 second tool change.

PART NUMBER	T ADAPTER SIZE	A
3812	3/4-12	.460
3817	1-1/16-12	
3822	1-3/8-12	
3830-FT	1-7/8-12	
4020	TR20 X 2.0MM	11.7MM
4028	TR28 X 2.0MM	
4036	TR36 X 2.0MM	

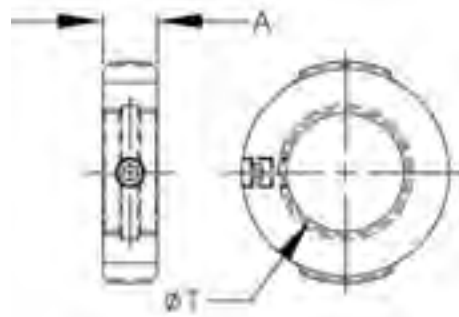

QUICK CHANGE CONVERSION NUT Ball-Lock™ for Acme & Metric Shanks



Features, Application, Ordering:

- ⇒ Must be used with Ball-Lock™ Over Spindle Adapters, see page 57.
- ⇒ Conversion nuts allow you to use your existing Acme shank tool holders and gain the advantage of 5 second tool change.

PART NUMBER	T ADAPTER SIZE	A	B
3110	5/8-16	.42	.40
3112	3/4-12		
3114	7/8-12		
3117	1-1/16-12		
3122	1-3/8-12		
3130	1-7/8-12		
3320	TR20 X 2.0MM	10.7MM	10.2MM
3328	TR28 X 2.0MM		
3336	TR36 X 2.0MM		

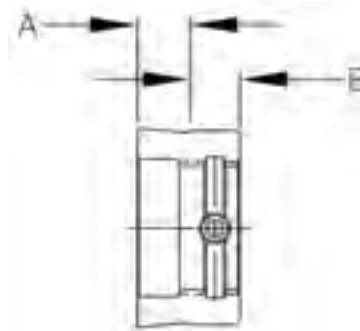

QUICK CHANGE DRILLING SYSTEMS



QUICK CHANGE CONVERSION NUT Sealed Ball-Lock™ for Acme & Metric Shanks



Features, Application, Ordering:

- ⇒ Must be used with Sealed Ball-Lock™ Over Spindle Adapters, see page 61.
- ⇒ Conversion nuts allow you to use your existing Acme shank tool holders and gain the advantage of 5 second tool change.

PART NUMBER	T ADAPTER SIZE	A
88N10	5/8-16	.80
88N12	3/4-12	
88N14	7/8-12	
88N17	1-1/16-12	
88N22	1-3/8-12	
88N30	1-7/8-12	
88N20	TR20 X 2.0MM	20.3MM
88N28	TR28 X 2.0MM	
88N36	TR36 X 2.0MM	

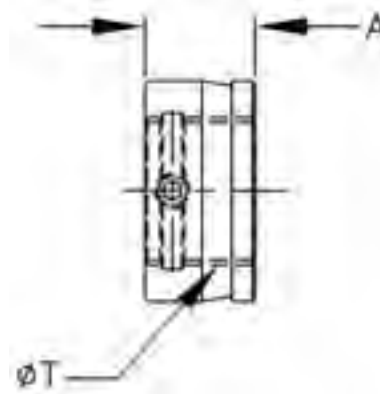

ADAPTER NUT Acme & Metric Shanks



Features, Application, Ordering:

- ⇒ Replacement adapter nut for all standard Acme Threaded shanks.

PART NUMBER	T ADAPTER SIZE	A
3606	3/8-20	.30
3608	1/2-16	.41
3610	5/8-16	
3612	3/4-12	
3614	7/8-12	
3616	1"-12	
3617	1-1/16-12	
3622	1-3/8-12	.63
3630	1-7/8-12	
36TR16	TR16 X 1.5MM	10.4MM
3620	TR20 X 2.0MM	
3628	TR28 X 2.0MM	
3636	TR36 X 2.0MM	

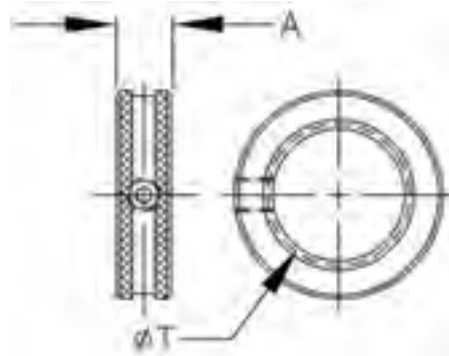

QUICK CHANGE DRILLING SYSTEMS



COOLANT INDUCERS FOR DRILL HOLDERS



Features, Application, Ordering:

- ⇒ Coolant inducer rated for pressures up to 1000 P.S.I.
- ⇒ Note: Spindle must be manufactured to accept the coolant inducer. Not compatible with standard ASA spindles.
- ⇒ Specials available upon request.

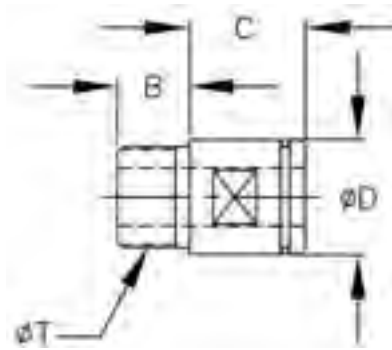

PART NUMBER	SPINDLE BORE	B	C	D	T	SEAL NUMBER
331-4013-SA11*	.563/.565	.62	1.00	.548/.552	3/8-24 LH	R-0132
331-4014-20	.625/.627	.62	1.00	.611/.615	7/16-20 LH	R-0142
331-4014-SA11	.625/.627	.62	1.00	.611/.615	7/16-20 LH	R-0142
331-4014-SA20	.750/.752	.62	1.00	.736/.740	9/16-18 LH	R-0162
331-4016-20	.750/.752	.62	1.00	.736/.740	7/16-20 LH	R-0162
332-4016-18	.750/.752	.62	1.00	.736/.740	3/4-16 LH	R-0162
332-4020-18	1.000/1.002	.62	1.00	.986/.990	7/8-14 LH	R-0202
332-4020-SA40*	1.000/1.002	.62	1.00	.986/.990	1-1/16-16 LH	R-0202
332-4020-SA32	1.000/1.002	.62	1.00	.986/.990	13/16-16LH	R-0202
332-4016-SA32	.750/.752	.62	1.00	.736/.740	7/8-14LH	R-0162

QUICK CHANGE DRILLING SYSTEMS



COLLET NUT WRENCH

⇒ Order Torque Wrench Separately (See below).

HEX OR SPANNER SIZE	COLLET SERIES	COLLET NUT NUMBER	STANDARD WRENCH
.47 DIA	SA8	SA8NCC	SA8SW
.67 HEX	SA11	SA11N	SA11HW
.63 DIA	SA11	SA11NCC	SA11SW
.98 HEX	SA16	SA16N	SA16HW
1.26 DIA	SA16	SA16NB	SA16SW
1.18 HEX	SA20	SA20N	SA20HW
1.65 DIA	SA25	SA25N	SA25SW
1.96 DIA	SA32	SA32N	SA32SW
2.48 DIA	SA40	SA40N	SA40SW
2.25 HEX	SG10	SG10N	SG10HW
2.38 DIA	SG10	SG10NB	SG10SW
3.50 DIA	SG15	SG15N	SG15SW



TORQUE WRENCH

- ⇒ Order Torque Adapters Separately.
- ⇒ Order by part number—SATW.
- ⇒ Range of Torque—30 to 150 ft lbs.
- ⇒ Length—16.5.
- ⇒ Spigot—16mm Dia.
- ⇒ See adapters below.



TORQUE WRENCH ADAPTERS

- ⇒ Used with Wrench #SATW (shown above).
- ⇒ Specials available upon request.



HEX OR SPANNER SIZE	COLLET SERIES	COLLET NUT NUMBER	TORQUE WRENCH ADAPTER
.98 HEX	SA16	SA16N	SA16HWT
1.18 HEX	SA20	SA20N	SA20HWT
1.65 DIA	SA25	SA25N	SA25SWT
1.96 DIA	SA32	SA32N	SA32SWT
2.48 DIA	SA40	SA40N	SA40SWT
2.25 HEX	SG10	SG10N	SG10HWT
2.38 DIA	SG10	SG10NB	SG10SWT
3.50 DIA	SG15	SG15N	SG15SWT

QUICK CHANGE DRILLING SYSTEMS



DRILL HOLDER LOCKING FIXTURES

⇒ Flats provided for easy use in table vises.

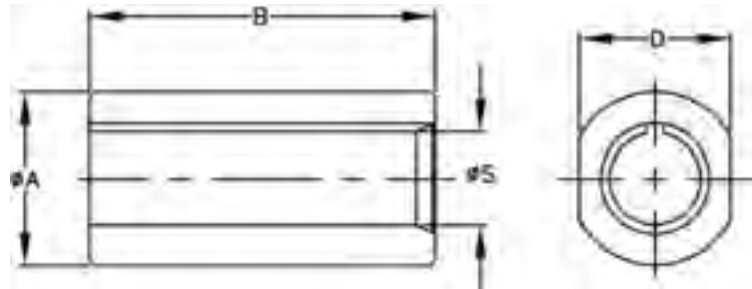

PART NUMBER	S SHANK SIZE	SHANK TYPE	A	B	D FLATS
TF-10*	5/8	ACME / TRU-TAPER	1.50	3.50	1.38
TF-12	3/4		1.50	4.00	1.38
TF-14	7/8		2.00	4.00	1.75
TF-17	1-1/16		2.00	4.00	1.75
TF-22	1-3/8		2.50	5.25	2.25
TFM-20*	20.00mm		1.50	4.00	1.38
TFM-28*	28.00mm		2.00	4.00	1.75
TFM-36*	36.00mm		2.50	5.25	2.25
TF-12-ST*	3/4	SUPER TAPER	1.50	4.00	1.38
TF-17-ST*	1-1/16		2.00	4.00	1.75

TAPER LOCKING FIXTURES

- ⇒ Flats provided for easy use in table vises.
- ⇒ Designed with Nylon inner sleeve to protect tapers from damage.

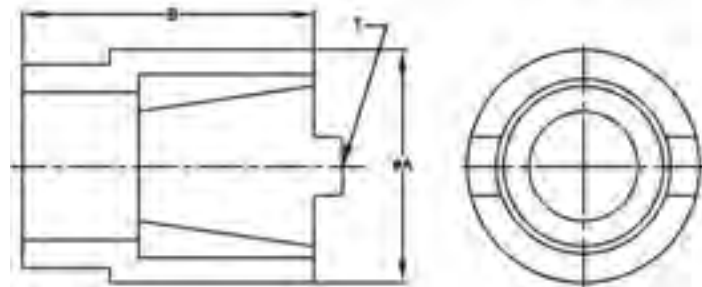

PART NUMBER	A	B	T SHANK SIZE & STYE	REPLACEMENT SLEEVE PART NUMBER
TF-C30-N*	2.00	3.00	CAT 30	TF-02-C30-N
TF-C40-N	3.00	3.25	CAT 40	TF-02-C40-N
TF-C50-N	4.00	5.00	CAT 50	TF-02-C50-N
TF-C60-N*	5.50	6.75	CAT 60	TF-02-C60-N
TF-H32A-N*	1.50	2.25	HSK 32 A,C	TF-02-H32A-N
TF-H40A-N*	1.75	2.50	HSK 40 A,C	TF-02-H40A-N
TF-H50A-N*	2.00	2.50	HSK 50 A,C	TF-02-H50A-N
TF-H63A-N*	2.50	2.75	HSK 63 A,C	TF-02-H63A-N
TF-H80A-N*	3.25	3.25	HSK 80 A,C	TF-02-H80A-N
TF-H100A-N*	4.00	4.00	HSK 100 A,C	TF-02-H100A-N



Shrink Fit tooling systems are designed to give you improved performance of your cutting tools with better finishes. One of the air frame manufactures recently switched an older machining center to Shrink Fit. In their testing they recorded 13X tool life improvement switching from ER collet chucks to a Shrink Fit holder. In a industry where you have to get the most out of your tooling it only make sense to use the best.

T.M. Smith Tool recognizes the latest DIN standards as well as the original USA design. The major difference in these designs is the contact angle for some heating and cooling systems and the DIN design has a preset screw. Our holders are proudly MADE IN THE USA.

SPECIAL DESIGNS AVAILABLE TO SUIT YOUR APPLICATION!

⇒ Contact our engineering department with your specifications, samples or drawings. We have over 120 years combined manufacturing and engineering experience to serve you. You can email us at engineering@tmsmith.com or visit our web site at <http://www.tmsmith.com>.



SHRINK FIT TOOLING



Shrink-fit tool holder technology has made a major impact in metal cutting since it was originally developed. The aerospace industry was first to take advantage of the performance benefits of induction heating the tool holder and shrink-fitting a cutting tool with a very close interference fit into it. The concentricity, for example, of shrink-fit tooling is consistently 0.0002-inches or better, improving balance and providing excellent rigidity for the tool and tool holder whether the holder is V-flange, CAT, BT or HSK. As a result, higher speeds and feeds can be obtained while maintaining and improving spindle life. Tool life has been extended from 100 to 400% in most cases. Claims are made that the induction heating process is reversible up to 50,000 times for an individual tool holder,



although many of those claims are yet to be proven, or realistically may not ever need to be.

So what's the difference?

It's all based on the temperature level at which the tool holder is induction heated and expanded. Gripping force is directly proportional to the amount of expansion and contraction. The higher the temperature, the larger the expansion, the tighter the contraction.

As a result, lower temperature means less gripping force, but still significantly higher gripping forces than conventional holders. Low temperature systems can also increase the cutting tool's cost. In most of the applications the user is required to use carbide shank tools because like metals expand at the same rate. The result is that more heat is required to remove a steel shank than a carbide shank. A low temp system, like slow heating systems, cannot take advantage of indexable and brazed tip tooling and usually have extraction problems with high speed steel. This is the one area that the high temp systems have a clear advantage, but at a premium cost. Most high temp machines run 2 to 4 times the cost of a low temp induction heating unit.

It's the application...it's the application...it's the application.

The required holding power or gripping force is determined by the application. What material is being machined? Is the cutting tool carbide or high-speed steel? What is the required ft-lbs of radial torque? All of these parameters need to be examined before a shrink-fit tool or system is selected.

There's No Magic Here

The principles of shrink-fit tool holders are simple. But like any other technology, misapplication, and a lack of understanding can cause headaches, especially when there is a cost premium. The ability to machine at higher RPM's, increased chip load and no moving parts on the tool holder are also advantages to consider.

Shrink fits are not the answer, but they can be the best solution in certain applications.



C 40 – E050 C– 300

Shank Style

C = V-Flange B5.50
 B = BT, MAS 403
 H = HSK DIN 69893
 S = Straight Shank

Taper / Size

30 = 30 Milling Machine
 35 = 35 Milling Machine
 40 = 40 Milling Machine
 45 = 45 Milling Machine
 50 = 50 Milling Machine

HSK Style

63A = Size 63 Form A
 63C = Size 63 Form C
 100A = Size 100 Form A
 100C = Size 100 Form C

Straight Shank

050 = .5000 Dia.
 075 = .7500 Dia.
 100 = 1.0000 Dia.
 125 = 1.2500 Dia.
 150 = 1.5000 Dia.
 200 = 2.0000 Dia.

Tool Style

A= Milling Arbor
 B= Blank Nose
 DA= Double Angle Collet
 E= End Mill
 J= Jacobs Male
 M= Morse Socket
 MC= Milling Chuck
 MX= MX Collet
 S= Shell Mill
 SA= ER Collet
 SD= Shrink Fit—DIN
 SF=Shrink Fit—USA
 SG= TG Collet
 SX= SX Collet
 TA= Tapping, Adjustable
 TC= Tapping, Coolant
 TR= Tapping, Rigid

Tool Size

025 = .2500 Dia.
 031 = .3125 Dia.
 037 = .3750 Dia.
 050 = .5000 Dia.
 062 = .6250 Dia.
 075 = .7500 Dia.
 087 = .8750 Dia.
 100 = 1.0000 Dia.
 125 = 1.2500 Dia.
 150 = 1.5000 Dia.
 200 = 2.0000 Dia.
 M6 = 6.000 Dia.
 M8 = 8.000 Dia.
 M10 = 10.000 Dia.
 M12 = 12.000 Dia.
 M16 = 16.000 Dia.
 M18 = 18.000 Dia.
 M24 = 24.000 Dia.

Jacobs Size

2= 2 Jacobs Taper
 3= 3 Jacobs Taper
 33= 33 Jacobs Taper
 4= 4 Jacobs Taper

Morse Size

2= 2 Morse Taper
 3= 3 Morse Taper
 4= 4 Morse Taper
 5= 5 Morse Taper

Tapping

0= 0 Size - 50 Series
 1= 1 Size - 51 Series
 2= 2 Size - 52 Series
 3= 3 Size - 53 Series

Options

A = Armorclad
 C = Coolant Thru
 * = Balanced: See note below for code letter.

Projection

Projection from Gage-line or location surface to over the nose or locating surface in inches.
 Example:
 100 = 1.00 Projection
 325 = 3.25 Projection

Balance Option

P = Production Balanced: Balanced by design, metal removed opposite set screws, key ways, etc. to counter balance the tool.

S = Dynamically Balanced tool holder at G2.5 @ 15,000 RPM in single balancing plane.

D = Dynamically Balanced tool holder at G2.5 @ 15,000 RPM in dual balancing planes. Note: Only available in extended length toolholders.

F = Dynamically Balanced tool holder at G2.5 @ 20,000 RPM in two balancing planes. Note: Only available in extended length toolholders.

Balanceable Option

B = Balanceable Holder with one row of balancing screws, pre-balanced to at G2.5 @ 15,000 RPM.

T = Balanceable Holder with two rows of balancing screws, pre-balanced to at G2.5 @ 15,000 RPM. Note: Projection of toolholder must be considered with this option. Contact our engineering department for details.

Premium Balance Option

Assembly balancing available with certification. Customer to specify Holder, Retention Knob, Collet and Tool shank size. A gage pin is locked into place to simulate cutting tool and the holder is balanced as an assembly at desired grade. Toolholders are then serialized and shipped with certification

Why Balanced Toolholders?

The need for balanced toolholders has always existed for applications with spindle speeds in excess of 10,000 RPM. Balanced toolholders are processed over special precision balancing equipment by either drilling or grinding to perform the dynamic balancing operation. This process reduces the out-of-balance condition, resulting in a precision balanced toolholder. Balanced toolholders have been proven to improve finish and extend the life of spindles in the machine tool.

The machine tool industry has standardized on ISO Grade G2.5 at speeds between 5,000 and 30,000 RPM. T.M. Smith Tool has the ability to meet and exceed these requirements through design and machine capability.

SHRINK FIT TOOLING



HSK Form "A" Adapters (DIN Design)

Features, Application, Ordering:

- ⇒ HSK Form "A" Shanks Conform to DIN 69893.
- ⇒ Coolant Thru Center (Order Tubes Separately).
- ⇒ Designed for Carbide and HSS Cutting Tools.
- ⇒ Inch & Odd size "A" I.D. available at No Extra Charge
- ⇒ Exclusively H-13 material
- ⇒ Specials available with Standard Delivery
- ⇒ Tool Shank tolerance h6.

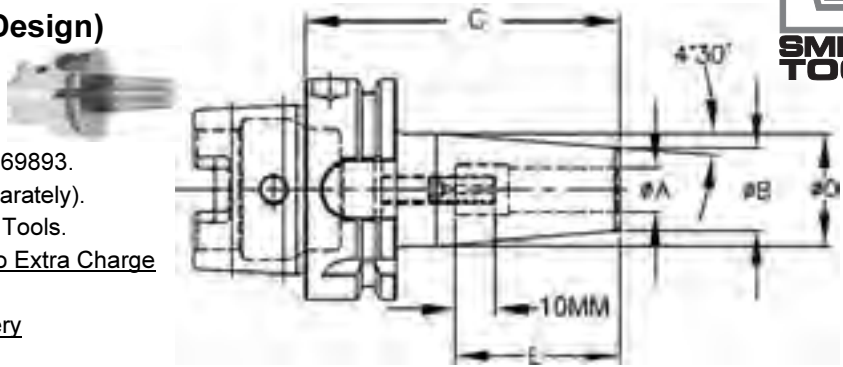

ALL DIMENSIONS
ARE METRIC

A	03	04	05	06	08	10	12	14	16	18	20	25	32
B	15	15	15	21	21	24	24	27	27	33	33	44	44
D	20	20	20	27	27	32	32	34	34	42	42	53	53
E	20	20	25	36	36	41	46	46	49	49	51	57	61

H32A															
H32ASDINxxMxxxM	Std	C	60	60	60	70	70	75	80						
H32ASDINxxM100M	Long	C				100	100								
H40A															
H40ASDINxxMxxxM	Std	C	60	60	60	80	80	80	90	90	90				
H40ASDINxxM130M	Long	C				130	130	130	130	130	130				
H50A															
H50ASDINxxMxxxM	Std	C	60	60	60	80	80	85	90	90	95				
H50ASDINxxM130M	Long	C				130	130	130	130	130	130				
H50ASDINxxM160M	X-Long	C				160	160	160	160	160	160				
H63A															
H63ASDINxxMxxxM	Std	C	80	80	80	80	80	85	90	90	95	95	100	115	120
H63ASDINxxM130M	Long	C				130	130	130	130	130	130	130	130	130	
H63ASDINxxM160M	X-Long	C				160	160	160	160	160	160	160	160	160	160
H63ASDINxxM200M	XX-Long	C				200	200	200	200	200	200	200	200	200	200
H80A															
H80ASDINxxMxxxM	Std	C				85	85	90	95	95	100	100	105	115	120
H80ASDINxxM130M	Long	C				130	130	130	130	130	130	130	130		
H80ASDINxxM160M	X-Long	C				160	160	160	160	160	160	160	160	160	160
H80ASDINxxM200M	XX-Long	C				200	200	200	200	200	200	200	200	200	200
H100A															
H100ASDINxxMxxxM	Std	C				85	85	90	95	95	100	100	105	115	120
H100ASDINxxM130M	Long	C				130	130	130	130	130	130	130	130	130	130
H100ASDINxxM160M	X-Long	C				160	160	160	160	160	160	160	160	160	160
H100ASDINxxM200M	XX-Long	C				200	200	200	200	200	200	200	200	200	200

Diameter "A"

Length "C"

Metric Example Part Number; H100ASDIN16M200M

Inch or Special Example Part Number; H100ASDIN375200M

ISG 2200WK combines shrinking technology with water cooling.

This system uses a new processor controlled high frequency generator, optimized coil geometry and predetermined parameters, making it possible to shrink Carbide and now also high speed steel tools quickly and easily.

The completely new water-cooling method considerably reduces cooling times in comparison with conventional cooling methods.

Tool clamping and changing can therefore be achieved in record time.

No overheating of the shrink chucks when used correctly, because predetermined parameters are used.

The danger of burns on heated shrink chucks is eliminated, because the chucks are moved to the cooling position by means of a pneumatic cylinder and access to the heated chucks is not possible.

Easy transition from parameter shrinking to manual shrinking.

Corrosion protection due to use of cooling emulsion.



Features and Facts:

- Processor controlled 8 kW high frequency generator
- Shrinking range Ø3-20mm Carbide and Ø6-20mm HSS, for woodworking up to Ø25mm Carbide and HSS
- Shrink length for HSK-63 max. 262mm
- Cooling length for HSK-63 up to max. 239mm
- For all standard tool spindles by means of a simple change of the tool location
- Can optionally be upgraded for HSK100 and Cat-50
- Optimal protection between coil and tool shank by means of 3 interchangeable discs with quick-changing
- Fully automatic shrinking and cooling process, fast tool change times of 30 seconds
- Cooling time can be set between 1 and 99 seconds
- 30 l coolant tank in the housing
- Working height 1040mm
- Cooling for all shrink chuck contours possible (DIN, USA & Custom)

PART NUMBER	D	W	H	CLAMPING RANGE	SUITABLE TOOL SHANKS	ELECTRIC CURRENT SUPPLY	POWER Kw	WEIGHT kg
TMS-35100044	550mm	700mm	1540mm	3-32mm solid carbide 6-32mm HSS, up to 25mm for	Carbide Tools, HSS	3x400V/16A	8	100

Shrinker is a registered trademark of Tooling Innovations, Dana Point, CA.

ISG 3200WK combines shrinking technology with water cooling.

ISG 3200WK combines shrinking technology with water cooling.

The universal all-in-one solution for tool changing in record times

- The ISG3200WK combines shrinking technology with water cooling. With the new all-in one solution the shrinking and cooling cycle is done in one position. By the automated process the heated shrinking chuck is moved down in the cooling position with a pneumatic cylinder after the heating time. In the cooling position the chuck is flooded directly with emulsion. After the set water cooling time the chuck moves upwards. During the movement the air is blowing drying the chuck. This completely new kind of cooling achieves a record tool change time. Contact with the heated chucks is not possible and so there is no danger of burns.



Features and Facts:

- Processor controlled 10 KW high frequency generator
- Shrinking range \varnothing 3 – 32 mm solid carbide and \varnothing 6 – 32 mm HSS with only 1 coil
- Second coil for shrinking range till \varnothing 50 mm
- Max. shrinking length 450 mm (can be increased optionally by extending the guide unit)
- Max. cooling length 400 mm
- Cooling of all shrinking chucks without separate cooling adaptors possible
- No danger of burning by touching the heated shrinking chucks
- No damage of the tool blade by the cooling adaptors
- For all standard tool spindles by means of a simple change of the tool holder
- Fully automatic shrinking and cooling process, fast tool change times of less than 30 seconds
- No overheating of the shrinking chucks while using programmed parameters
- Manual shrinking cycle for free adjustment of generator power and heating time
- Easy control by graphic display with dialog function
- Adjustable delay time for every shrinking cycle
- Corrosion protection by use of emulsion, 30 l coolant tank in the housing

PART NUMBER	D	W	H	CLAMPING RANGE	SUITABLE TOOL SHANKS	ELECTRIC CURRENT SUPPLY	POWER Kw	WEIGHT kg
TMS-3639082755	620mm	700mm	1700mm	3-32mm carbide, 6-32mm HSS	Carbide Tools	3x400V/16A	10	172

Shrinker is a registered trademark of Tooling Innovations, Dana Point, CA.

SHRINK FIT MACHINES



T.M. Smith offers two variations of this machine designed for the most cost effective tool change. The most important part of any Shrink Fit system is the ability to remove the cutting tool effectively. Our systems are designed to work with Carbide and Steel cutting tool shanks. We provide you with the option to choose the best system for your machining application.

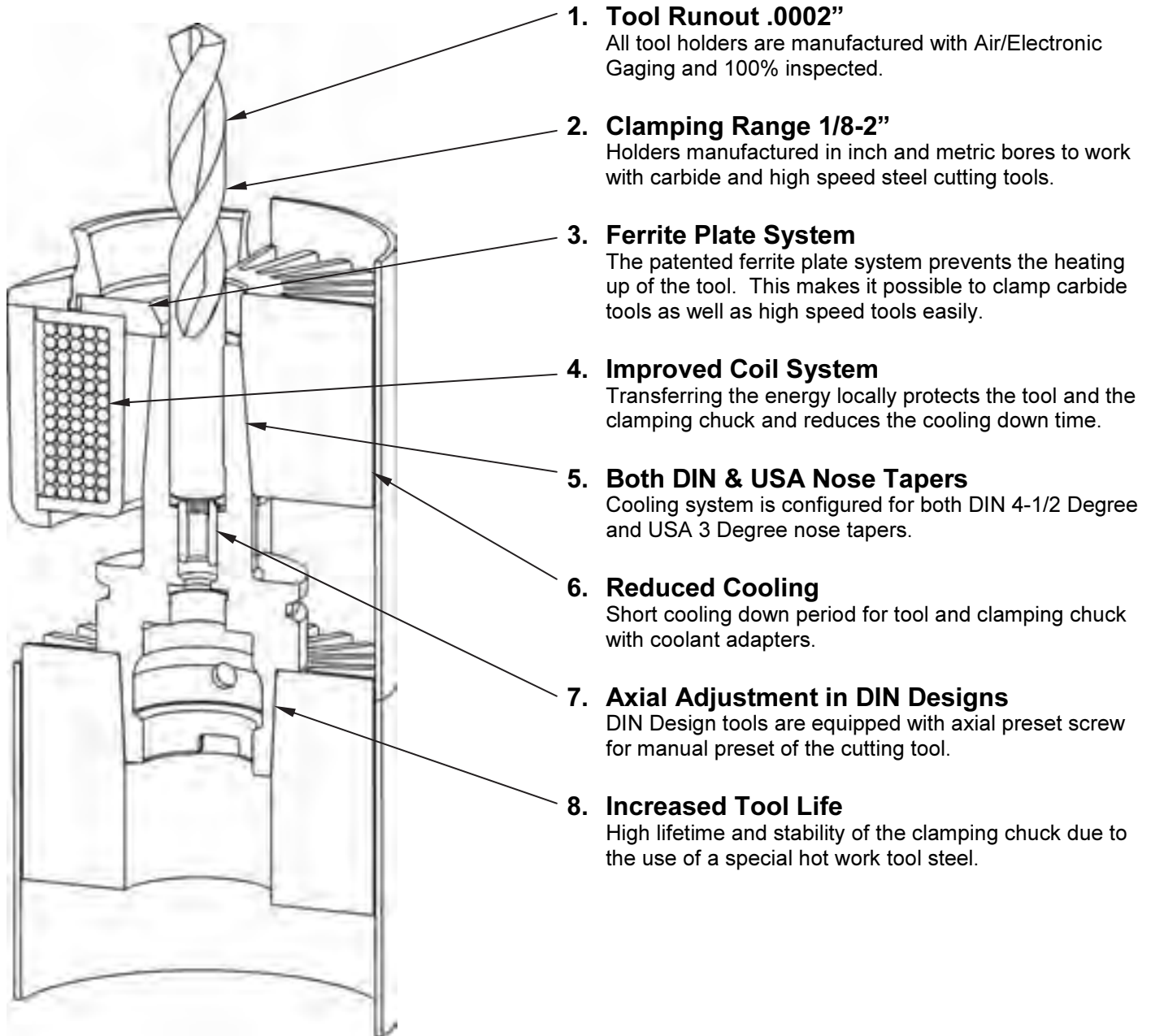

1. Tool Runout .0002"

All tool holders are manufactured with Air/Electronic Gaging and 100% inspected.

2. Clamping Range 1/8-2"

Holders manufactured in inch and metric bores to work with carbide and high speed steel cutting tools.

3. Ferrite Plate System

The patented ferrite plate system prevents the heating up of the tool. This makes it possible to clamp carbide tools as well as high speed tools easily.

4. Improved Coil System

Transferring the energy locally protects the tool and the clamping chuck and reduces the cooling down time.

5. Both DIN & USA Nose Tapers

Cooling system is configured for both DIN 4-1/2 Degree and USA 3 Degree nose tapers.

6. Reduced Cooling

Short cooling down period for tool and clamping chuck with coolant adapters.

7. Axial Adjustment in DIN Designs

DIN Design tools are equipped with axial preset screw for manual preset of the cutting tool.

8. Increased Tool Life

High lifetime and stability of the clamping chuck due to the use of a special hot work tool steel.

SHRINK FIT MACHINES



ISG-2200 - Entry level Induction Unit



Mobile Unit for use in the tool presetting area or locally at the machining center.

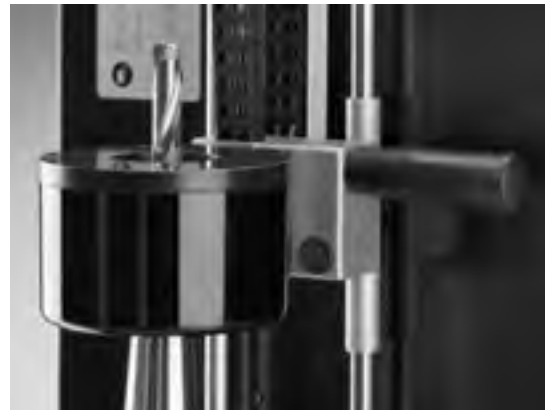

The coil is moved manually into the required heating position. There it is locked into position by pressing a button. After the heating operation the coil returns to the home position automatically. This avoids overheating of the coil and clamping chuck.

The mobile unit represents an inexpensive initial move into inductive shrinking technology. The low weight means that it can be used flexibly wherever it is required. Despite the compact design, it allows tool changing for diameters 1/4" - 3/4" within seconds. The integrated fan cools down the clamping chucks quickly. This machine offers all the features for easy and safe use of the shrinking technology in your production. This machine is suitable for carbide tools only.

PART NUMBER	D	W	H	CLAMPING RANGE	SUITABLE TOOL SHANKS	ELECTRIC CURRENT SUPPLY	POWER Kw	WEIGHT kg
TMS-35100017	390mm	310mm	640mm	1/4" - 3/4"	Carbide Tools	3x208V/8.5A	3	25

Shrinker is a registered trademark of Tooling Innovations, Dana Point, CA.

SHRINK FIT MACHINES



Processor Controlled Cooling Station



The cooling station with two additional cooling positions makes it possible to increase the number of cooling positions on all of the ISG shrinking machines. The double cooling station is processor controlled, meaning that the operation time of each cooling fan can be adjusted separately.

PART NUMBER	D	W	H	ELECTRIC CURRENT SUPPLY	WEIGHT kg
TMS-35100003	270mm	380mm	120mm	120V	5.8

Shrinker is a registered trademark of Tooling Innovations, Dana Point, CA.

SHRINK FIT MACHINES



ISG-3200 - The Performance Class for Continual Tool Changing



Universal Table Mount

On this automatically controlled unit all that needs to be done is select the tool diameter range. After the start button is pressed, the induction coil moves automatically to the tool holder, heats the tool and moves back to the home position.

ISG 3200 is a universal shrinking unit for the production use of the shrinking technology. With its unique coil changing system, the power transfer adjusted to the different holder sizes is guaranteed within a short period of time. Compared to other systems, this makes it possible to shrink the smallest diameters (1/4" - 2") with high speed tools as well as down to 1/8" with carbide tools. With a range of special coils, the unit can be suited to other special applications. Four integrated fans make it possible to cool down the tool holders evenly in a short time. The fans are activated automatically by a light barrier as soon as the chuck is pushed into the cooling position. This means that constant preparation of a high number of tools can be guaranteed.

Shrinker is a registered trademark of Tooling Innovations, Dana Point, CA.

SHRINK FIT MACHINES



Because of the well thought out design of the working surface, the tools can be moved easily from the shrinking into the cooling position. The greatest importance was attached to the use of especially high quality and resistant materials for continuous use in the workshop area.



Operation of the ISG 3200 is completely menu assisted. The data is shown in the graphics display. All shrinking parameters are displayed simultaneously. The integrated processor controls not only the power and duration of heating automatically, but it also enables the data for chucks with special geometry to be stored. Four LEDs indicate which fan is in operation.

PART NUMBER	D	W	H	CLAMPING RANGE	SUITABLE TOOL SHANKS	ELECTRIC CURRENT SUPPLY	POWER Kw	WEIGHT kg
TMS-36300001	584mm	592mm	1030mm	1/8" - 2"	Carbide & High Speed Steel Tools	3x400V/16A	10	43

Shrinker is a registered trademark of Tooling Innovations, Dana Point, CA.

SHRINK FIT MACHINES



INDUCTION COIL

Features, Application, Ordering:

- ⇒ ISG 3200 Machine includes (1) TMS-36300003
- ⇒ Special coils available upon request.

PART NUMBER	CLAMPING RANGE
TMS-36300003	6mm-32mm
TMS-36300004	32mm-50mm



COIL LOCATION PLATES

Features, Application, Ordering:

- ⇒ ISG 3200 Machine includes (1) complete set
- ⇒ Special coils available upon request.

PART NUMBER	CLAMPING RANGE
TMS-36300005	6mm-12mm
TMS-36300006	12.1mm-20mm
TMS-36300007	20.1mm-32mm



TOOL HOLDERS

Features, Application, Ordering:

- ⇒ Special coils available upon request.

PART NUMBER	CLAMPING RANGE
TMS-36100127	CAT-30 / SK30
TMS-36100113	CAT-40 / SK40
TMS-36100114	CAT-50 / SK50
TMS-36100108	HSK-32A,C
TMS-36100109	HSK-40A,C,E / HSK50F
TMS-36100110	HSK-50A,C,E / HSK63F
TMS-36100111	HSK-63A,C,E
TMS-36100112	HSK-80A,C,E
TMS-36100107	HSK-100A,C,E
TMS-36100117	TAP ADAPTER SIZE 1
TMS-36100118	TAP ADAPTER SIZE 2



SHRINK FIT MACHINES



COOLING ADAPTERS

Features, Application, Ordering:

⇒ Special coils available upon request.

DIN STYLE 4-1/2 DEGREE NOSE TAPER

TOOL DIAMETER METRIC	TOOL DIAMETER INCH	TOOL PROJECTION	PART NUMBER	TOOL PROJECTION	PART NUMBER
6-9	1/4 - 5/16	3.15 - 4.72 80MM - 120MM	TMS-36100124	4.73 - 7.87 121MM - 200MM	TMS-36100193
9.1-12	3/8 - 1/2		TMS-36100125		TMS-36100194
12.1-16	5/8		TMS-36100120		TMS-36100195
16.1-22	3/4		TMS-36100122		TMS-36100196
22.1-32	7/8 - 1-1/4		TMS-36100123		TMS-36100197
32.1-40	1-3/8 - 1-1/2		TMS-36100175		TMS-36100175
40.1-50	1-5/8 - 1-7/8		TMS-36100210		TMS-36100210



USA STYLE 3 DEGREE NOSE TAPER

TOOL DIAMETER METRIC	TOOL DIAMETER INCH	TOOL PROJECTION	PART NUMBER	TOOL PROJECTION	PART NUMBER
	3/16	2.36 - 4.72 60MM - 120MM	TMS-361-018-1	4.73 - 7.87 121MM - 200MM	TMS-361-018-2
6	1/4		TMS-361-025-1		TMS-361-025-2
10	3/8		TMS-361-037-1		TMS-361-037-2
12	1/2		TMS-361-050-1		TMS-361-050-2
16	5/8		TMS-361-062-1		TMS-361-062-2
20	3/4		TMS-361-075-1		TMS-361-075-2
25	1		TMS-361-100-1		TMS-361-100-2
32	1-1/4		TMS-361-125-1		TMS-361-125-2
40	1-1/2		TMS-361-150-1		TMS-361-150-2

COOLING ADAPTER BLANKS

TOOL DIAMETER METRIC	TOOL PROJECTION	PART NUMBER
0	2.36 - 4.72 60MM - 120MM	TMS-36100208
18		TMS-36100200
35		TMS-36100201

COOLING PLATE

Features, Application, Ordering:

⇒ By installing this cooling plate on the fan units, the cutting tools can be kept safely while cooling down.



PART NUMBER
TMS-36100173

Shrinker is a registered trademark of Tooling Innovations, Dana Point, CA.

T.M. Smith offers a complete line of CNC tool holders in Cat, BT & HSK built in our factory in Michigan. T.M. Smith has invested in “State of the Art” equipment and gaging to provide the best possible tool at a competitive price. All Cat & BT tooling are manufactured to ISO AT3 or better on taper tolerance. All HSK holders are inspected on Air Electronic gaging.

Special Designs to suit your application.

⇒ Contact our engineering department with your specifications, samples or drawings. We have over 120 years combined manufacturing and engineering experience to serve you. You can email us at engineering@tmsmith.com or visit our web site at <http://www.tmsmith.com>.



CNC SYSTEMS

COLLET CHUCKS Single Angle (ER) CAT "V" Flange Shanks - B5.50-1994



Features, Application, Ordering:

- ⇒ Coolant Thru
 - Must be used with Coolant Collet or Coolant Disk Nut
 - For Coolant Disk Nut add a "CD" to the part number - Single Angle Only!
- ⇒ Order Collets Separately, see page 41.
- ⇒ Specials Available Upon Request.
- ⇒ Identification chip is not included.
- ⇒ TG & DA Collet Holders are available upon request.

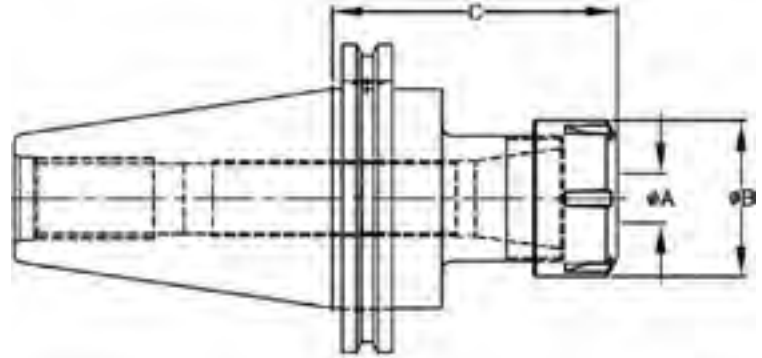

PART NUMBER	SHANK	COLLET SERIES	A COLLET RANGE	B DIA	C	COLLET NUT	NUT TIGHTENING TORQUE FT/LBS
C40SA11250	CAT-40	ER11	.0428-.2500	.75	2.50	SA11N	17
C40SA11400		ER11	.0428-.2500	.75	4.00	SA11N	17
C40SA11600		ER11	.0428-.2500	.75	6.00	SA11N	17
C40SA16276		ER16	.0428-.4062	1.10	2.76	SA16N	45
C40SA16400		ER16	.0428-.4062	1.10	4.00	SA16N	45
C40SA16600		ER16	.0428-.4062	1.10	6.00	SA16N	45
C40SA20276		ER20	.0544-.5110	1.34	2.76	SA20N	65
C40SA20400		ER20	.0544-.5110	1.34	4.00	SA20N	65
C40SA20600		ER20	.0544-.5110	1.34	6.00	SA20N	65
C40SA25276		ER25	.0544-.6290	1.65	2.76	SA25N	80
C40SA25400		ER25	.0544-.6290	1.65	4.00	SA25N	80
C40SA32276		ER32	.0544-.7870	1.97	2.76	SA32N	100
C40SA32400		ER32	.0544-.7870	1.97	4.00	SA32N	100
C40SA40315		ER40	.0856-1.020	2.48	3.15	SA40N	120
C50SA16400		CAT-50	ER16	.0428-.4062	1.10	4.00	SA16N
C50SA16600	ER16		.0428-.4062	1.10	6.00	SA16N	45
C50SA20400	ER20		.0544-.5110	1.34	4.00	SA20N	65
C50SA20600	ER20		.0544-.5110	1.34	6.00	SA20N	65
C50SA25400	ER25		.0544-.6290	1.65	4.00	SA25N	80
C50SA32400	ER32		.0544-.7870	1.97	4.00	SA32N	100
C50SA32600	ER32		.0544-.7870	1.97	6.00	SA32N	100
C50SA40400	ER40		.0856-1.020	2.48	4.00	SA40N	120

CNC SYSTEMS



END MILL ADAPTERS Cat "V" Flange Shanks B5.50-1994

Features, Application, Ordering:

- ⇒ For Weldon style end mills.
- ⇒ Coolant Thru
- ⇒ Specials Available Upon Request
- ⇒ Identification chip is not included.

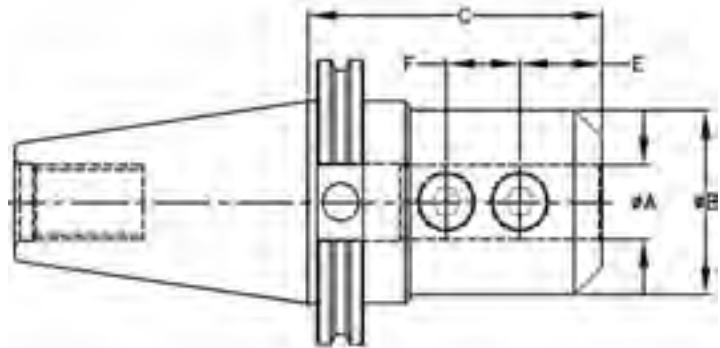

PART NUMBER	SHANK	A	B	C	E	F
C40E012238	CAT-40	.1250	.690	2.38	.370	N/A
C40E018250		.1875	.690	2.50	.562	N/A
C40E025175		.2500	.780	1.75	.630	N/A
C40E025300		.2500	.780	3.00	.630	N/A
C40E031300		.3125	.880	3.00	.600	N/A
C40E037175		.3750	.880	1.75	.781	N/A
C40E037300		.3750	.880	3.00	.781	N/A
C40E043300		.4375	1.130	3.00	.812	N/A
C40E050175		.5000	1.250	1.75	.875	N/A
C40E050250		.5000	1.250	2.50	.875	N/A
C40E062175		.6250	1.500	1.75	.937	N/A
C40E062300		.6250	1.500	3.00	.937	N/A
C40E075175		.7500	1.750	1.75	1.000	N/A
C40E075350		.7500	1.750	3.50	1.000	N/A
C40E100175		1.000	2.000	1.75	1.125	1.000
C40E100400		1.000	2.000	4.00	1.125	1.000
C40E125200		1.250	2.50	2.00	1.125	1.000
C40E125400		1.250	2.50	4.00	1.125	1.000

CNC SYSTEMS



END MILL ADAPTERS Cat "V" Flange Shanks B5.50-1994

Features, Application, Ordering:

- ⇒ For Weldon style end mills.
- ⇒ Coolant Thru
- ⇒ Specials Available Upon Request
- ⇒ Identification chip is not included.

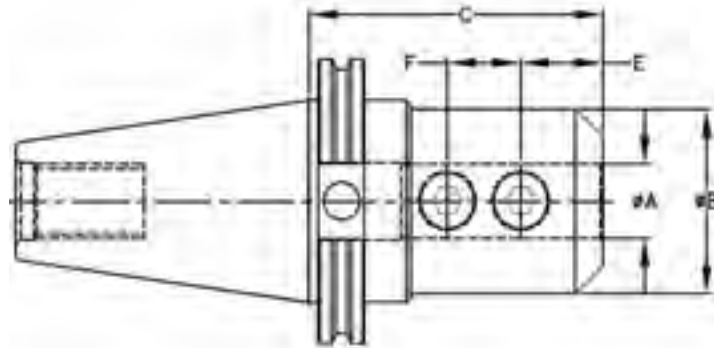

PART NUMBER	SHANK	A	B	C	E	F
C50E025400	CAT-50	.2500	.78	4.00	.63	N/A
C50E037400		.3750	1.00	4.00	.75	N/A
C50E050262		.5000	1.25	2.62	.88	N/A
C50E050400		.5000	1.25	4.00	.88	N/A
C50E062400		.6250	1.50	4.00	.93	N/A
C50E075400		.7500	1.75	4.00	1.00	N/A
C50E075600		.7500	1.75	6.00	1.00	N/A
C50E100400		1.0000	2.00	4.00	1.13	2.13
C50E100600		1.00	2.00	6.00	1.13	2.13
C50E125460		1.2500	2.50	4.60	1.12	1.00

SOFT BLANK—FINISHED SHANK HSK, CAT & BT Shanks

Features, Application, Ordering:

- ⇒ Soft blanks are manufactured from 6150, 8620 designated by the part number. Shanks are hardened to industry standards and the nose ends are drawn to Rock "C" 25-32.
- ⇒ Specials Available Upon Request
- ⇒ Identification chip is not included.

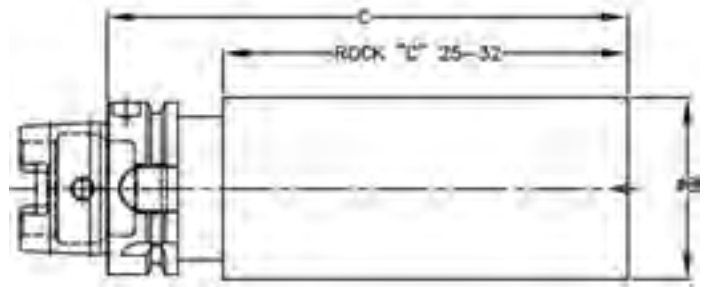

PART NUMBER	SHANK	MATERIAL	B	C
H63A-B300-700-6*	HSK-63A	6150	3.00	7.00
H63A-B262-750-6		6150	2.62	7.50
H63A-B262-750-H		H13	2.62	7.50
H100A-B394-700-6	HSK-100A	6150	3.94	7.00
H100A-B394-700-H		H13	3.94	7.00
H100A-B394-700-4*		4320	3.94	7.00
C40-B300-700-8*	CAT-40	8620	3.00	7.00
C40-B262-650-8		8620	2.62	6.50
C40-B400-400-8*		8620	4.00	4.00
C40-B262-400-H		H13	2.62	4.00
C40-B262-650-H		H13	2.62	6.50
C50-B400-600-8*	CAT-50	8620	4.00	6.00
C50-B275-475-8		8620	2.75	4.75
C50-B275-700-8		8620	2.75	7.00
C50-B275-700-H		H13	2.75	7.00
B40-B300-700-8	BT-40	8620	3.00	7.00
B40-B400-500-8*		8620	4.00	5.00

HP3 DRILL CHUCKS



HP3 PRECISION DRILL CHUCK HSK, CAT & BT Shanks

Features, Application, Ordering:

- ⇒ .0008 Maximum Runout (TIR)
- ⇒ 4 Times the holding power of normal drill chucks
- ⇒ High Speed Design—10,000 RPM
- ⇒ Integral Design—Will not separate during operation
- ⇒ Specials Available Upon Request



PART NUMBER	SHANK	CHUCK RANGE	NOSE DIAMETER	PROJECTION
B30-HP3	BT-30	0-1/2"	1.969	3.642
B40-HP3	BT-40			3.760
B50-HP3	BT-50			4.193
C40-HP3	CAT-40			4.055
C50-HP3	CAT-50			3.445
H63A-HP3	HSK-63A			4.862
H63F-HP3	HSK-63F			4.862

KEY & KEYLESS DRILL CHUCKS



DRILL CHUCKS

Features, Application, Ordering:

⇒ Heavy Duty and industrial design with exceptional quality. All parts are hardened & ground to ensure high accuracy, durability and gripping power.

KEY CHUCKS—STANDARD DUTY

PART NUMBER	JACOBS TAPER	CHUCK RANGE	OD	LENGTH CLOSED
TMS-02216	#2 JACOBS	0-3/8"	1.496	2.480
TMS-02217	#6 JACOBS	0-1/2"	1.772	3.071
TMS-02218	#6 JACOBS	0-5/8"	2.165	3.583
TMS-02219	#3 JACOBS	0-5/8"	2.165	3.583



KEY CHUCKS—HEAVY DUTY

PART NUMBER	JACOBS TAPER	CHUCK RANGE	OD	LENGTH CLOSED
TMS-02225	#6 JACOBS	0-1/2"	2.067	3.189
TMS-02228	#4 JACOBS	0-3/4"	2.874	4.725



KEYLESS CHUCKS—STANDARD DUTY

PART NUMBER	JACOBS TAPER	CHUCK RANGE	OD	LENGTH CLOSED
TMS-02114	#2 JACOBS	0-3/8"	1.693	3.622
TMS-02116	#6 JACOBS	0-1/2"	1.929	4.016
TMS-02118	#6 JACOBS	1/8-5/8"	2.165	4.331
TMS-02120	#3 JACOBS	1/8-5/8"	2.165	4.331



KEYLESS CHUCKS—HIGH PRECISION

PART NUMBER	JACOBS TAPER	CHUCK RANGE	OD	LENGTH CLOSED	MAXIMUM RUNOUT
TMS-02151	#2 JACOBS	0-3/8"	1.693	3.622	.0015 @ 2"
TMS-02153	#6 JACOBS	0-1/2"	1.929	4.016	.0015 @ 2"



SITC—Short Tension & Compression Quick-Change Tap Holder HSK, CAT & BT Shanks



For Tang Drive Adapters Only!

Features, Application, Ordering:

- ⇒ For use with Tang Drive Adapters Only!
Order Adapters Separately, see page 24.
- ⇒ Hard Start Design: Can be locked out for Full Tension Use!

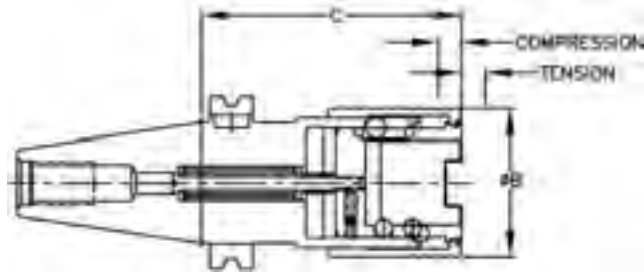

PART NUMBER	TAP RANGE	SHANK	B DIA.	C	TENSION	COMPESSION
741-H40A-TC	SIZE 1 0-9/16 HAND	HSK-40A	1.61	3.14	.35	.35
741-H50A-TC		HSK-50A		2.93		
741-H63A-TC		HSK-63A		2.83		
741-H100A-TC		HSK-100A		3.14		
741-C30-TC		CAT-30		2.36		
741-C40-TC		CAT-40		2.36		
741-C50-TC		CAT-50		2.44		
741-B30-TC		BT-30		2.48		
741-B40-TC		BT-40		2.68		
741-B50-TC		BT-50		3.15		
742-H50A-TC	SIZE 2 5/16-7/8 HAND	HSK-50A	2.36	4.33	.59	.59
742-H63A-TC		HSK-63A		4.33		
742-H100A-TC		HSK-100A		3.94		
742-C30-TC		CAT-30		3.98		
742-C40-TC		CAT-40		3.94		
742-C50-TC		CAT-50		3.27		
742-B30-TC		BT-30		3.78		
742-B40-TC		BT-40		3.66		
742-B50-TC		BT-50		4.02		
743-C40-TC	SIZE 3 3/4-1-3/8 HAND	CAT-40	3.38	5.43	.94	.94
743-C50-TC		CAT-50		5.24		
743-B40-TC		BT-40		5.43		
743-B50-TC		BT-50		5.31		

CNC COLLET CHUCKS & SHELL MILL ADAPTERS MADE TO ORDER WITH STD DELIVERY

HSK Shanks - DIN 69893



COLLET CHUCKS Single Angle (ER)

Features, Application, Ordering:

- ⇒ Holder includes Standard Preset Screw
- ⇒ Coolant Thru Preset Screw
- ⇒ Order Collets Separately
- ⇒ Identification chip & coolant tube not included
- ⇒ Can be used with Coolant Collet or Coolant Disk Nut
- ⇒ For Coolant Disk Nut add a "CD" to the part number—(Single Angle Only)
- ⇒ For close center conditions all collet holders can be provided with Mini Nuts also

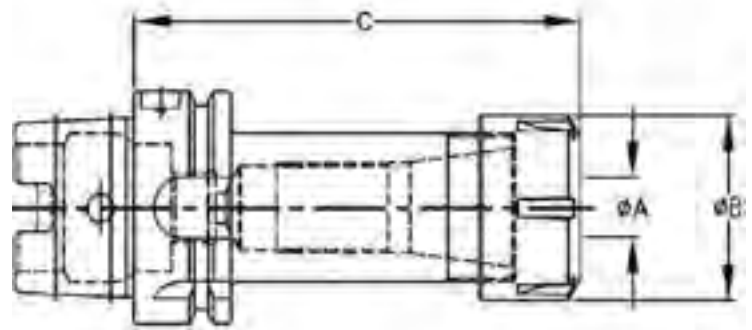

SHELL MILL ADAPTERS

Features, Application, Ordering:

- ⇒ Standard Screw & Keys included.
- ⇒ Coolant Thru
- ⇒ Identification chip & coolant tube not included

Just provide shank size & drive key size with the four dimensions when ordering

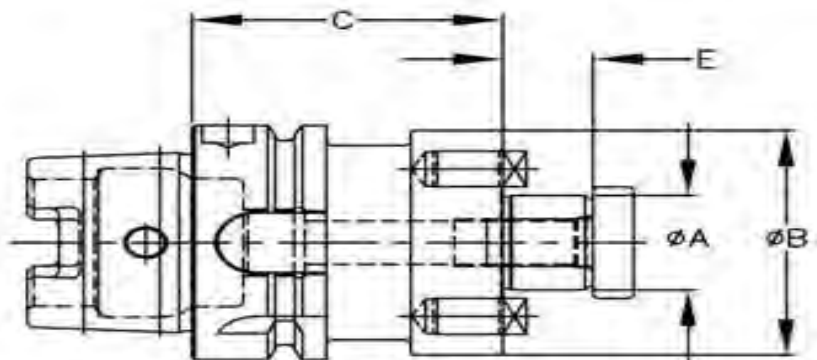

**SITH Quick-Change Rigid Tap & Reamer Holder
HSK, CAT & BT Shanks**



Features, Application, Ordering:

- ⇒ Coolant Thru
- ⇒ Identification chip is not included.
- ⇒ For use with machines with synchronized feed and spindle rotation.
- ⇒ Order Adapters Separately, see page 24.
- ⇒ Optional rust resistant chrome finish, add "ST" to the part number.
- ⇒ Specials Available Upon Request
- ⇒ Accepts Bilz, Collis, Universal, Lyndex and many other tap adapters.

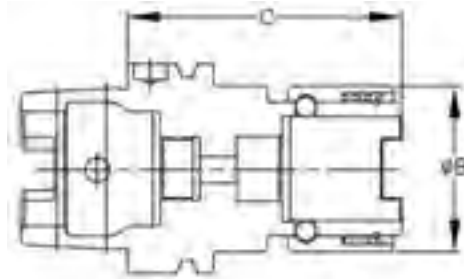

PART NUMBER	SHANK	TAP RANGE	B DIA.	C
H63A-TR1-244	HSK-63A	SIZE 1 0-9/16 HAND	1.26	2.44
H63A-TR2-325		SIZE 2 5/16-7/8 HAND	1.96	3.25
H100A-TR1-269	HSK-100A	SIZE 1 0-9/16 HAND	1.26	2.69
H100A-TR2-378		SIZE 2 5/16-7/8 HAND	1.96	3.50
C40-TR1-250	CAT-40	SIZE 1 0-9/16 HAND	1.26	2.50
C40-TR2-300		SIZE 2 5/16-7/8 HAND	1.96	3.00
C50-TR1-300	CAT-50	SIZE 1 0-9/16 HAND	1.26	3.00
C50-TR2-300		SIZE 2 5/16-7/8 HAND	1.96	3.00
C50-TR3-400		SIZE 3 3/4-1-3/8 HAND	2.83	4.00
B40-TR1-236	BT-40	SIZE 1 0-9/16 HAND	1.26	2.36
B40-TR2-315		SIZE 2 5/16-7/8 HAND	1.96	3.15

**ACTH Adjustable Tension & Compression Quick-Change Tap Holder
CAT & BT Shanks**



Features, Application, Ordering:

- ⇒ Adjustable Mechanism, allows the customer to customize the amount of tension/compression stroke.
- ⇒ Order Adapters Separately, see page 23.
- ⇒ Specials Available Upon Request
- ⇒ Accepts Bilz, Collis, Universal, Lyndex and many other tap adapters.

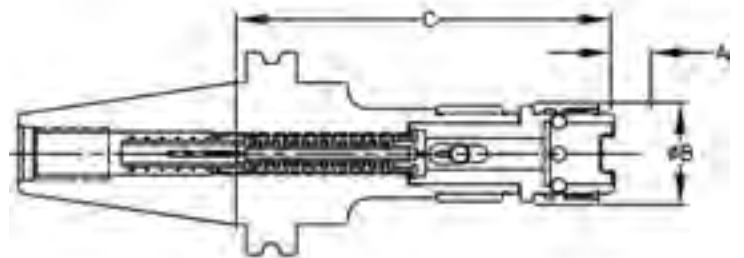

PART NUMBER	SHANK	TAP RANGE	B	C	T TENSION
C40-TA1-467	CAT-40	0-9/16, 1/8 NPT	1.26	4.67	.50
C40-TA2-629		5/16-7/8, 1/4-1/2 NPT	1.96	6.29	.88
C50-TA1-391	CAT-50	0-9/16, 1/8 NPT	1.26	3.91	.50
C50-TA2-554		5/16-7/8, 1/4-1/2 NPT	1.96	5.54	.88
C50-TA3-850		3/4-1 3/8, 3/4-1 NPT	2.91	8.5	1.38
B40-TA1-467*	BT-40	0-9/16, 1/8 NPT	1.26	4.92	.50
B40-TA2-629*		5/16-7/8, 1/4-1/2 NPT	1.96	6.5	.88

HSK63A End Mill Extensions

Features, Application, Ordering:

- ⇒ Designed to give maximum rigidity at extended length.
- ⇒ They are available in 4", 6", and 9" projections.
- ⇒ Holder includes lock screw.
- ⇒ Identification chip and coolant tube not included.
- ⇒ Also available in all HSK, CAT, BT and NMTB Shank Sizes

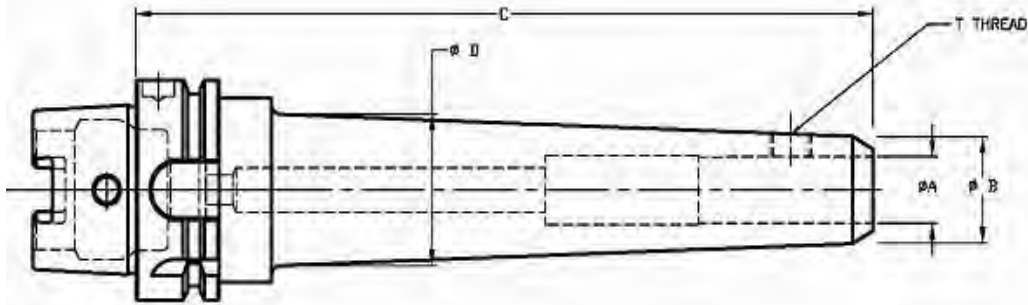

PART NUMBER	A	B	C	D	T
H63AEX012-400	.125	.38	4.00	.56	#6-32
H63AEX012-600	.125	.38	6.00	.70	#6-32
H63AEX012-900	.125	.38	9.00	.91	#6-32
H63AEX018-400	.187	.44	4.00	.62	#10-32
H63AEX018-600	.187	.44	6.00	.76	#10-32
H63AEX018-900	.187	.44	9.00	.97	#10-32
H63AEX025-400	.250	.50	4.00	.68	#10-32
H63AEX025-600	.250	.50	6.00	.82	#10-32
H63AEX025-900	.250	.50	9.00	1.03	#10-32
H63AEX031-400	.312	.56	4.00	.74	1/4-24
H63AEX031-600	.312	.56	6.00	.88	1/4-24
H63AEX031-900	.312	.56	9.00	1.09	1/4-24
H63AEX037-400	.375	.75	4.00	.92	5/16-24
H63AEX037-600	.375	.75	6.00	1.06	5/16-24
H63AEX037-900	.375	.75	9.00	1.27	5/16-24
H63AEX043-400	.437	.81	4.00	.98	3/8-24
H63AEX043-600	.437	.81	6.00	1.12	3/8-24
H63AEX043-900	.437	.81	9.00	1.33	3/8-24
H63AEX050-400	.500	.88	4.00	1.05	7/16-20
H63AEX050-600	.500	.88	6.00	1.19	7/16-20
H63AEX050-900	.500	.88	9.00	1.40	7/16-20
H63AEX056-400	.562	.94	4.00	1.11	1/2-20
H63AEX056-600	.562	.94	6.00	1.25	1/2-20
H63AEX056-900	.562	.94	9.00	1.46	1/2-20
H63AEX062-400	.625	1.06	4.00	1.23	1/2-20
H63AEX062-600	.625	1.06	6.00	1.37	1/2-20
H63AEX062-900	.625	1.06	9.00	1.58	1/2-20
H63AEX075-400	.750	1.19	4.00	1.36	1/2-20
H63AEX075-600	.750	1.19	6.00	1.50	1/2-20
H63AEX075-900	.750	1.19	9.00	1.71	1/2-20
H63AEX087-400	.875	1.31	4.00	1.48	5/8-18
H63AEX087-600	.875	1.31	6.00	1.62	5/8-18
H63AEX087-900	.875	1.31	9.00	1.75	5/8-18
H63AEX100-400	1.000	1.62	4.00	1.75	5/8-18
H63AEX100-600	1.000	1.62	6.00	1.75	5/8-18
H63AEX100-900	1.000	1.62	9.00	1.75	5/8-18
H63AEX125-400	1.250	1.75	4.00	2.04	5/8-18
H63AEX125-600	1.250	1.75	6.00	2.18	5/8-18
H63AEX125-900	1.250	1.75	9.00	2.39	5/8-18

**CTDH STRAIGHT SHANK
Single angle Collet Chucks**



Features, Application, Ordering:

- ⇒ Accurate stub drilling holder.
- ⇒ Coolant Thru
 - Must be used with Coolant Collet or Coolant Disk Nut.
 - For Coolant Disk Nut add a "CD" to the part number.
- ⇒ Order Collets Separately, see page 38.
- ⇒ Optional rust resistant chrome finish, add "ST" to the part number.
- ⇒ Specials Available Upon Request.

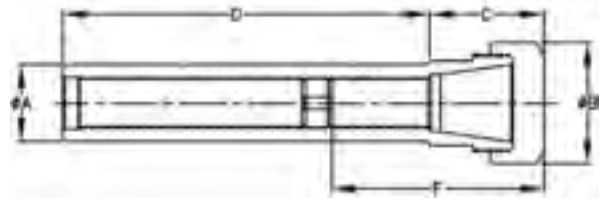

PART NUMBER	TOOL DIA RANGE	COLLET SERIES	A	B	C	D	F MIN.	F MAX.	NUT HEX	PRESET SCREW	MAX TOOL DIA.	COLLET NUT	COLLET NUT TORQUE
S037-SA8-394*	.020-.197	SA8	.375	0.48	0.95	3.94	0.75	2.86	-	PSM6C	.197	SA8NCC	10
S050-SA11-550*	.020-.276	SA11	.500	0.63	1.04	5.50	1.00	3.00	-	PS05C	.276	SA11NCC	17
S075-SA16-600	.020-.393	SA16	.750	1.10	1.18	6.00	1.31	4.22	25mm	PSM12C	.393	SA16N	45
S100-SA25-600*	.039-.630	SA25	1.000	1.66	1.81		1.65	7.03	-	PS11C	.609	SA25N	80
S125-SA32-600	.098-.750	SA32	1.250	1.97	2.06		1.90	7.11	-	PS13C	.750	SA32N	100
S150-SA40-600*	.098-1.000	SA40	1.500	2.48	2.69		2.14	7.94	-	PS18C	1.000	SA40N	120
S150-SG10-600*	.094-1.000	SG10	1.500	2.25	2.69		2.74	7.94	2.25	PS18C	1.000	SG10N	85
S200-SG15-800*	.500-1.500	SG15	2.000	3.25	4.00		8.00	3.77	11.22	-	PS26C	1.500	SG15N

**CTDH STRAIGHT SHANK
Double angle Collet Chucks**



Features, Application, Ordering:

- ⇒ Accurate stub drilling holder.
- ⇒ Coolant capable at request
- ⇒ Order Collets Separately, see page 46.
- ⇒ Optional rust resistant chrome finish, add "ST" to the part number.
- ⇒ Specials Available Upon Request.

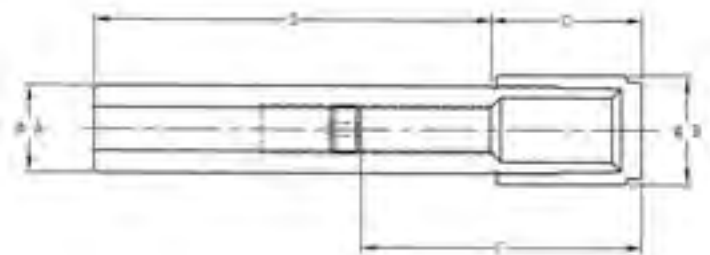

PART NUMBER	TOOL DIA RANGE	COLLET SERIES	A	B	C	D	F MIN.	F MAX.	NUT HEX	PRESET SCREW	MAX TOOL DIA.	COLLET NUT	COLLET NUT TORQUE
S050-DA30-550	.047-.250	DA30	.500	.55	1.38	5.50	1.6	4.0	1/2	PS05	.250	DA30NCC	20
S075-DA20-550	.062-.375	DA20	.750	.87	1.69	5.50	1.5	4.6	3/4	PS07	.375	DA20NCC	25
S100-DA10-550	.062-.562	DA10	1.000	1.07	1.94	5.50	2.2	4.7	15/16	PS10	.562	DA10NCC	35
S125-DA18-550	.062-.750	DA18	1.250	1.44	1.83	5.50	2.0	4.6	1 1/4	PS13	.750	DA18NCC	45

GENERAL INFORMATION



Shipment subject to floods, fires, strikes, accidents or other conditions beyond the controls of T.M. Smith Tool International Corp. F.O.B. Mt. Clemens, Michigan. Right of possession and the title pass to customer upon delivery to carrier.

Catalog items are subject to existing or pending United States and/or foreign patents. All Warranties expressed or implied, are hereby excluded from all sales by T.M. Smith Tool International Corp., including but not limited to, all warranties of merchantability of fitness for a particular purpose.

Payment terms are Net 30 Days.

Prices subject to change without notice.

Repair packages must be installed by authorized T.M. Smith Tool International Corp. repair center. All repairs done outside of T.M. Smith Tool International Corp. repair centers will void any and all expressed or implied warranties.

The repair package does not guarantee the tool will function the same as a new tool. The package replaces wear components only. Any tool determined by T.M. Smith Tool International Corp. to be un-repairable can be disposed of by T.M. Smith Tool International Corp. or returned to the customer at the customer's expense. Tools may be returned un-assembled.

Product Returns:

Defective material or material shipped in error by T.M. Smith Tool International Corp., is returnable without charge. All other returns are subject to a restocking charge of not less than 15%.

Returns must be pre-approved and include a Return Material Authorization (RMA) number issued by T.M. Smith Tool International Corp..

All returns must be in new and saleable condition and are subject to inspection.

Freight must be prepaid on all returns.

Any item returned without prior approval or not passing inspection will be returned to sender at senders cost.

Items defined as Specials or Non-Stock items are non-returnable.

No item may be returned after six months from date of original shipment to the customer.



INDEX



<u>PART NUMBER</u>	<u>PAGE#</u>	<u>PART NUMBER</u>	<u>PAGE#</u>	<u>PART NUMBER</u>	<u>PAGE#</u>
105.....	66	88017.....	61	117-243	66
107.....	66	88022.....	61	117-303	66
109.....	66	101-212	62	117-373	66
112.....	66	101-214	62	117-443	66
114.....	66	101-217	62	117-514	66
117.....	66	102-217	62	120-M712*	7
3010.....	57	102-222	62	121-212C.....	21
3012.....	57	104-210	62	121-217C*	21
3014.....	57	104-212	62	121-C-51.....	7
3017.....	57	104-214*	62	101-217	62
3022.....	57	105-094	66	102-217	62
3030.....	57	105-122	66	102-222	62
3110.....	67	105-162	66	104-210	62
3112.....	67	105-214*	62	104-212	62
3114.....	67	105-217	62	104-214*	62
3117.....	67	107-094	66	105-094	66
3122.....	67	107-122	66	105-122	66
3130.....	67	107-162	66	105-162	66
3320.....	67	107-203	66	105-214*	62
3328.....	67	107-217	62	105-217	62
3336.....	67	107-222*	62	107-094	66
3606.....	68	108-222	62	107-122	66
3608.....	68	108-230*	62	107-162	66
3610.....	68	109-094	66	107-203	66
3612.....	68	109-122	66	107-217	62
3614.....	68	109-162	66	107-222*	62
3616.....	68	109-203	66	108-222	62
3617.....	68	109-243	66	108-230*	62
3620.....	68	109-303	66	109-094	66
3622.....	68	109-373	66	109-122	66
3628.....	68	112-162	66	109-162	66
3630.....	68	112-203	66	109-203	66
3636.....	68	112-243	66	109-243	66
3712.....	55	112-303	66	109-303	66
3717.....	55	112-373	66	109-373	66
3722.....	55	112-443	66	112-162	66
3812.....	67	114-162	66	112-203	66
3817.....	67	114-203	66	112-243	66
3822.....	67	114-243	66	112-303	66
4020.....	67	114-303	66	112-373	66
4028.....	67	114-373	66	112-443	66
4036.....	67	114-443	66	114-162	66
88010.....	61	117-122	66	114-203	66
88012.....	61	117-162	66	114-243	66
88014.....	61	117-203	66	114-303	66

* Denotes "Non-Stock" item.

INDEX



<u>PART NUMBER</u>	<u>PAGE#</u>	<u>PART NUMBER</u>	<u>PAGE#</u>	<u>PART NUMBER</u>	<u>PAGE#</u>
114-373	66	3012-SS.....	57	3220-SS.....	57
114-443	66	3014-SS.....	57	322-1-217-FT*	17
117-122	66	3017-SS.....	57	322-1-222-FT*	17
117-162	66	3022-SS.....	57	322-1-302-FT*	18
117-203	66	311-51-217	16	322-1-303-FT*	18
117-243	66	311-51-222	16	322-1-TR28-FT*	17
117-303	66	311-51-716	16	322-1-TR36-FT*	17
117-373	66	311-51-TR28*	16	322-2-217-FT*	17
117-443	66	311-C-51-T	8	322-2-222-FT*	17
117-514	66	312-52-217	16	322-2-302-FT*	18
120-M712*	7	312-52-222	16	322-2-303-FT*	18
121-212C.....	21	312-52-716	16	322-3-217-FT*	17
121-217C*	21	312-52-720	16	322-3-222-FT*	17
121-C-51.....	7	312-52-TR28*	16	322-3-302-FT*	18
223-732	14	312-52-TR36*	16	322-3-303-FT*	18
223-740	14	312-C-52-T	8	322-4-217-FT.....	17
223-H100A	14	313-52-TR36*	16	322-4-222-FT.....	17
223-H80A	14	313-53-222	16	322-4-302-FT*	18
223-TR36.....	12	313-53-720	16	322-4-303-FT*	18
243-SA32-728	15	313-53-724*	16	322-4-TR28-FT*	17
251-50-M712*	7	321-1-212-FT*	17	322-4-TR36-FT*	17
251-SA11-210	15	321-1-217-FT*	17	3228-SS.....	57
251-SA11-212	15	321-1-302-FT*	18	323-3-222-FT.....	17
251-SA11-710	15	321-1-303-FT*	18	323-3-304-FT*	18
251-SA11-712	15	321-1-TR20-FT*	17	323-3-TR36-FT*	17
253-51-M716*	7	321-1-TR28-FT*	17	3236-SS.....	57
253-SA20-212	15	321-2-212-FT*	17	331-4013-SA11*	69
253-SA20-214	15	321-2-217-FT*	17	331-4014-20	69
253-SA20-217	15	321-2-302-FT*	18	331-4014-SA11	69
253-SA20-712	15	321-2-303-FT*	18	331-4014-SA20	69
253-SA20-716	15	321-3-212-FT*	17	331-4016-20	69
253-SA20-720	15	321-3-217-FT*	17	331-712*	56
253-SA20-TR20	15	321-3-302-FT*	18	331-717	56
253-SA20-TR28.....	15	321-3-303-FT*	18	332-4016-18	69
254-52-M720*	7	321-4-212-FT*	17	332-4020-18	69
254-SA32-217	15	321-4-217-FT*	17	332-4020-SA40*	69
254-SA32-222	15	321-4-302-FT*	18	332-717	56
254-SA32-716	15	321-4-303-FT*	18	332-722	56
254-SA32-720	15	321-5-212-FT.....	17	341-720*	56
254-SA32-724	15	321-5-217-FT.....	17	341-728*	56
254SA32-TR28.....	15	321-5-222-FT.....	17	342-728*	56
254SA32-TR36.....	15	321-5-302-FT*	18	342-736*	56
256-53-M732*	7	321-5-303-FT*	18	351-712*	54
256-SA40-238	15	321-5-TR20-FT*	17	351-717*	54
3010-SS.....	57	321-5-TR28-FT*	17	352-717*	54

* Denotes "Non-Stock" item.

INDEX



<u>PART NUMBER</u> <u>PAGE#</u>	<u>PART NUMBER</u> <u>PAGE#</u>	<u>PART NUMBER</u> <u>PAGE#</u>
352-722* 54	401-006* 36	401-112-214T 19
361-720* 54	401-006-208T 20	401-112-216T* 19
361-728* 54	401-006-210T 20	401-112-217T 19
362-728* 54	401-006-212T 20	401-202-210T 20
362-736* 54	401-006-214T 20	401-202-212T 20
36TR16 68	401-006-216T* 20	401-202-214T 20
3712-SS 55	401-006-217T 20	401-202-216T* 20
3712-SST 58	401-007* 36	401-202-217T 20
3717-SS 55	401-007-210T 20	402-000* 36
3717-SST 58	401-007-212T 20	402-001* 36
3722-SS 55	401-007-214T 20	402-002* 36
3920-SS* 55	401-007-216T* 20	402-003* 36
3928-SS 55	401-007-217T 20	402-009-217T 20
3936-SS* 55	401-008* 36	402-009-222T 20
400-000* 36	401-008-210T 20	402-010-217T 20
400-001* 36	401-008-212T 20	402-010-222T 20
400-002* 36	401-008-214T 20	402-011-217T 20
400-004-206T* 19	401-008-216T* 20	402-011-222T 20
400-004-208T 19	401-008-217T 20	402-012-217T 20
400-106-206T* 19	401-009-210T 20	402-012-222T 20
400-106-208T 19	401-009-212T 20	402-013-217T 20
400-108-206T* 19	401-009-214T 20	402-013-222T 20
400-108-208T 19	401-009-216T* 20	402-014-217T 20
400-110-206T* 19	401-009-217T 20	402-014-222T 20
400-110-208T 19	401-106-208T 19	402-202-217T 20
400-112-206T* 19	401-106-210T 19	402-202-222T 20
400-112-208T 19	401-106-212T 19	402-204-217T 20
401-000 36	401-106-214T 19	402-204-222T 20
401-001 36	401-106-216T* 19	402-206-217T 20
401-002 36	401-106-217T 19	402-206-222T 20
401-003 36	401-108-208T 19	402-208-217T 20
401-004 36	401-108-210T 19	402-208-222T 20
401-004-208T 19	401-108-212T 19	50-004 27
401-004-210T 19	401-108-214T 19	50-004-0 34
401-004-212T 19	401-108-216T* 19	50-106 27
401-004-214T 19	401-108-217T 19	50-106-0* 34
401-004-216T* 19	401-110-208T 19	50-108 27
401-004-217T 19	401-110-210T 19	50-108-0* 34
401-005* 36	401-110-212T 19	50-110 27
401-005-208T 20	401-110-214T 19	50-110-0* 34
401-005-210T 20	401-110-216T* 19	50-112* 27
401-005-212T 20	401-110-217T 19	50-112-0* 34
401-005-214T 20	401-112-208T 19	51-004 27
401-005-216T* 20	401-112-210T 19	51-004-0 34
401-005-217T 20	401-112-212T 19	51-004-0-T* 35

* Denotes "Non-Stock" item.

INDEX



<u>PART NUMBER</u> <u>PAGE#</u>	<u>PART NUMBER</u> <u>PAGE#</u>	<u>PART NUMBER</u> <u>PAGE#</u>
51-004TD..... 28	51-202TD..... 28	51-SA20-T005 33
51-005 27	51-2040 31	51-SA20-T006 33
51-005-0 34	51-2060 31	51-SA20-T007 33
51-005-0-T* 35	51-2080 31	51-SA20-T008 33
51-005TD..... 28	51-40355* 29	51-SA20-T009 33
51-006 27	51-40400* 29	51-SA20-T010 33
51-006-0 34	51-40450* 29	52-004-0* 34
51-006-0-T* 35	51-40500* 29	52-005 28
51-006TD..... 28	51-40560* 29	52-005-0* 34
51-007 27	51-40630* 29	52-005TD..... 28
51-007-0 34	51-40710* 29	52-006 27
51-007-0-T* 35	51-40800* 29	52-006-0* 34
51-007TD..... 28	51-40900* 29	52-006TD..... 28
51-008 27	51-41000 30	52-007 27
51-008-0 34	51-41000* 29	52-007-0* 34
51-008-0-T* 35	51-50350 30	52-007TD..... 28
51-008TD..... 28	51-50400 30	52-008 27
51-009 26	51-50450 30	52-008-0* 34
51-009-0 34	51-50600 30	52-008TD..... 28
51-009-0-T* 34	51-50700 30	52-009 27
51-009TD..... 28	51-50800 30	52-009-0* 34
51-010 31	51-50900 30	52-009TD..... 28
51-011* 31	51-SA16-004* 37	52-010 27
51-012* 31	51-SA16-005* 37	52-010-0 34
51-013* 31	51-SA16-006* 37	52-010TD..... 28
51-014* 31	51-SA16-007* 37	52-011 27
51-106 27	51-SA16-008* 37	52-011-0 34
51-106-0* 34	51-SA16-R0..... 33	52-011TD..... 28
51-106-0-T* 35	51-SA16-R094* 33	52-012 27
51-106TD..... 28	51-SA16-R122* 33	52-012-0 34
51-108 27	51-SA16-R162..... 33	52-012TD..... 28
51-108-0 34	51-SA16-R203..... 33	52-013 27
51-108-0-T* 35	51-SA16-T004* 33	52-013-0 34
51-108TD..... 28	51-SA16-T005 33	52-013TD..... 28
51-110 27	51-SA16-T006 33	52-014 27
51-110-0 34	51-SA16-T007* 33	52-014-0 34
51-110-0-T* 35	51-SA16-T008 33	52-014TD..... 28
51-110TD..... 28	51-SA20-R0..... 33	52-015* 31
51-112 27	51-SA20-R094..... 33	52-016 31
51-112-0* 34	51-SA20-R122..... 33	52-018 31
51-112-0-T* 35	51-SA20-R162..... 33	52-020* 31
51-112TD..... 28	51-SA20-R203..... 33	52-022* 31
51-202 27	51-SA20-R243..... 33	52-106-0** 34
51-202-0 34	51-SA20-R303..... 33	52-108-0** 34
51-202-0-T* 35	51-SA20-T004 33	52-110-0** 34

* Denotes "Non-Stock" item.

INDEX



PART NUMBER	PAGE#	PART NUMBER	PAGE#	PART NUMBER	PAGE#
52-112-0**	34	52-SA32-R203*	33	53-42000	30
52-202	27	52-SA32-R243*	33	53-42240*	29
52-202-0*	34	52-SA32-R303*	33	53-42500*	29
52-202TD	28	52-SA32-R373*	33	53-42500	30
52-204	27	52-SA32-R443	33	53-51800	30
52-204-0	34	52-SA32-T009*	33	53-52200	30
52-204TD	28	52-SA32-T010*	33	61-004TD	32
52-206	27	52-SA32-T011*	33	61-005TD	32
52-206-0	34	52-SA32-T012*	33	61-006TD	32
52-206TD	28	52-SA32-T013*	33	61-007TD	32
52-208	27	52-SA32-T014*	33	61-008TD	32
52-208-0	33	53-012	27	61-009TD	32
52-208TD	27	53-012TD	28	61-106TD	32
52-2120	31	53-013*	27	61-108TD	32
52-2160	31	53-013TD	28	61-110TD	32
52-40800*	29	53-014*	27	61-112TD	32
52-40900*	29	53-014TD	28	61-202TD	32
52-41000	30	53-015	27	62-006TD	32
52-41000*	29	53-015TD	28	62-007TD	32
52-41120*	29	53-016	27	62-008TD	32
52-41250*	29	53-016TD	28	62-009TD	32
52-41400*	29	53-018	27	62-010TD	32
52-41600*	29	53-018TD	28	62-011TD	32
52-50600	30	53-020	27	62-012TD	32
52-50700	30	53-020TD	28	62-013TD	32
52-50800	30	53-022	27	62-014TD	32
52-50900	30	53-022TD	28	62-204TD	32
52-51100	30	53-024*	31	62-206TD	32
52-51200	30	53-026*	31	62-208TD	32
52-51400	30	53-028*	31	63-012TD	32
52-51600	30	53-030*	31	63-013TD	32
52-51800	30	53-032*	31	63-014TD	32
52-SA16-004*	37	53-034*	31	63-015TD	32
52-SA16-005*	37	53-036*	31	63-016TD	32
52-SA16-006*	37	53-038*	31	63-018TD	32
52-SA16-007*	37	53-040*	31	63-020TD	32
52-SA16-008*	37	53-212	27	63-022TD	32
52-SA32-009*	37	53-212TD	28	63-212TD	32
52-SA32-010*	37	53-216	27	63-216TD	32
52-SA32-011*	37	53-216TD	28	741-B30-TC	89
52-SA32-012*	37	53-2200*	31	741-B40-TC	89
52-SA32-013*	37	53-2240*	31	741-B50-TC	89
52-SA32-014*	37	53-2320*	31	741-C30-TC	89
52-SA32-R0*	33	53-41800*	29	741-C40-TC	89
52-SA32-R162*	33	53-42000*	29	741-C50-TC	89

* Denotes "Non-Stock" item.

INDEX



<u>PART NUMBER</u>	<u>PAGE#</u>	<u>PART NUMBER</u>	<u>PAGE#</u>	<u>PART NUMBER</u>	<u>PAGE#</u>
741-H100A-TC	89	88020-SS.....	61	C40-SA16-400.....	84
741-H40A-TC	89	88022-SS.....	61	C40-SA16-600.....	84
741-H50A-TC	89	88028-SS.....	61	C40-SA20-276.....	84
741-H63A-TC	89	88036-SS.....	61	C40-SA20-400.....	84
741-M716-TC	8	881-710*.....	60	C40-SA20-600.....	84
742-B30-TC	89	882-710*.....	60	C40-SA25-276.....	84
742-B40-TC	89	882-712	60	C40-SA25-400.....	84
742-B50-TC	89	882-717*.....	60	C40-SA32-276.....	84
742-C30-TC.....	89	882-720	60	C40-SA32-400.....	84
742-C40-TC.....	89	882-728*.....	60	C40-SA40-315.....	84
742-C50-TC.....	89	883-712*.....	60	C40-TA1-467	91
742-H100A-TC	89	883-714*.....	60	C40-TA2-629	91
742-H50A-TC	89	883-720*.....	60	C40-TR1-250.....	91
742-H63A-TC	89	885-717	60	C40-TR2-300.....	91
742-M716-TC	8	885-722*.....	60	C50-710-TT*.....	65
743-B40-TC	89	885-728	60	C50-712-ST*.....	65
743-B50-TC	89	885-736*.....	60	C50-712-TT*.....	65
743-C40-TC.....	89	886-722	60	C50-714-TT*.....	65
743-C50-TC.....	89	886-736	60	C50-717-ST*.....	65
743-M724-TC	8	88N10.....	68	C50-717-TT*.....	65
801-712	54	88N12.....	68	C50-720-TT*.....	65
801-717	54	88N14.....	68	C50-722-TT*.....	65
802-717	54	88N17.....	68	C50-728-TT*.....	65
802-722	54	88N20.....	68	C50-736-TT*.....	65
811-710	56	88N22.....	68	C50-B275-475-8.....	86
811-712	56	88N28.....	68	C50-B275-700-8.....	86
811-717	56	88N30.....	68	C50-B275-700-H	86
812-717	56	88N36.....	68	C50-B400-600-8*.....	86
812-722	56	B30-HP3.....	87	C50-E025-138	85
821-720	54	B40-HP3.....	87	C50-E025-250	85
821-728*.....	54	B50-HP3.....	87	C50-E025-400	85
822-728	54	C40-B262-400-H	86	C50-E031-250	85
822-736*.....	54	C40-B262-650-8	86	C50-E031-400	85
825-712	58	C40-B262-650-H	86	C50-E037-250	85
825-717	58	C40-B300-700-8*.....	86	C50-E037-400	85
831-720	56	C40-B400-400-8*.....	86	C50-E043-250	85
831-728*.....	56	C40-DA18-300.....	86	C50-E043-400	85
832-728	65	C40-DA18-400*.....	86	C50-E050-175	85
832-736*.....	56	C40-DA20-300.....	86	C50-E050-250	85
88010*.....	61	C40-DA20-400*.....	86	C50-E050-400	85
88010-SS.....	61	C40-HP3.....	87	C50-E062-175	85
88012-SS.....	61	C40-SA11-250.....	84	C50-E062-300	85
88014*.....	61	C40-SA11-400.....	84	C50-E062-400	85
88014-SS.....	61	C40-SA11-600.....	84	C50-E075-175	85
88017-SS.....	61	C40-SA16-276.....	84	C50-E075-300	85

* Denotes "Non-Stock" item.

INDEX



PART NUMBER	PAGE#	PART NUMBER	PAGE#	PART NUMBER	PAGE#
C50-E075-400	85	DA10-0516	46	DA18-0625	46
C50-E087-175	85	DA10-0531	46	DA18-0641	46
C50-E087-350	85	DA10-0547	46	DA18-0656	46
C50-E100-200	85	DA10-0562	46	DA18-0672	46
C50-E100-400	85	DA10-SET15	47	DA18-0688	46
C50-E125-200	85	DA10-SET21	47	DA18-0703	46
C50-E125-400	85	DA10-SET29	47	DA18-0719	46
C50-E150-450	85	DA10-SET33	47	DA18-0734	46
C50-E200-400	85	DA10-SET8	47	DA18-0750	46
C50-HP3.....	87	DA18-0062	46	DA18N	48
C50-TA1-391	91	DA18-0078	46	DA18N-C100	49
C50-TA2-554	91	DA18-0094	46	DA18N-C105	49
C50-TA3-850	91	DA18-0109	46	DA18N-C110	49
C50-TR1-300.....	91	DA18-0125	46	DA18N-C115	49
C50-TR2-300.....	91	DA18-0141	46	DA18N-C120	49
C50-TR3-400.....	91	DA18-0156	46	DA18N-C125	49
DA10-0062	46	DA18-0172	46	DA18N-C130	49
DA10-0078	46	DA18-0187	46	DA18N-C135	49
DA10-0094	46	DA18-0203	46	DA18N-C140	49
DA10-0109	46	DA18-0219	46	DA18N-C145	49
DA10-0125	46	DA18-0234	46	DA18N-C150	49
DA10-0141	46	DA18-0250	46	DA18N-C155	49
DA10-0156	46	DA18-0266	46	DA18N-C160	49
DA10-0172	46	DA18-0281	46	DA18N-C165	49
DA10-0187	46	DA18-0297	46	DA18N-C170	49
DA10-0203	46	DA18-0312	46	DA18N-C175	49
DA10-0219	46	DA18-0328	46	DA18N-C180	49
DA10-0234	46	DA18-0344	46	DA18N-C185	49
DA10-0250	46	DA18-0359	46	DA18N-C190	49
DA10-0266	46	DA18-0375	46	DA18N-C195	49
DA10-0281	46	DA18-0391	46	DA18N-C35	49
DA10-0297	46	DA18-0406	46	DA18N-C40	49
DA10-0312	46	DA18-0422	46	DA18N-C45	49
DA10-0328	46	DA18-0437	46	DA18N-C50	49
DA10-0344	46	DA18-0453	46	DA18N-C55	49
DA10-0359	46	DA18-0469	46	DA18N-C60	49
DA10-0375	46	DA18-0484	46	DA18N-C65	49
DA10-0391	46	DA18-0500	46	DA18N-C70	49
DA10-0406	46	DA18-0516	46	DA18N-C75	49
DA10-0422	46	DA18-0531	46	DA18N-C80	49
DA10-0437	46	DA18-0547	46	DA18N-C85	49
DA10-0453	46	DA18-0562	46	DA18N-C90	49
DA10-0469	46	DA18-0578	46	DA18N-C95	49
DA10-0484	46	DA18-0594	46	DA18-SET17	47
DA10-0500	46	DA18-0609	46	DA18-SET21	47

* Denotes "Non-Stock" item.

INDEX



PART NUMBER	PAGE#	PART NUMBER	PAGE#	PART NUMBER	PAGE#
DA18-SET33	47	DA30-0094	46	PS26C-609*	22
DA18-SET41	47	DA30-0109	46	PS26C-817*	22
DA18-SET9	47	DA30-0125	46	S037-SA8-394*	93
DA20-0062	46	DA30-0141	46	S050-DA30-550	93
DA20-0078	46	DA30-0156	46	S050-SA11-550*	93
DA20-0094	46	DA30-0172	46	S075-DA20-550	93
DA20-0109	46	DA30-0187	46	S075-SA16-600	93
DA20-0125	46	DA30-0203	46	S100-DA10-550	93
DA20-0141	46	DA30-0219	46	S100-SA25-600*	93
DA20-0156	46	DA30-0234	46	S125-DA18-550	93
DA20-0172	46	DA30-0250	46	S125-SA32-600	93
DA20-0187	46	DA30-SET14	47	S150-SA40-600*	93
DA20-0203	46	DA30-SET7	47	S150-SG10-600*	93
DA20-0219	46	H100ASDIN thru H32ASDIN	75	S200-SG15-800*	93
DA20-0234	46	PS07C-094	22	SA11-1/16.....	40
DA20-0250	46	PS07C-122	22	SA11-1/4.....	40
DA20-0266	46	PS07C-162	22	SA11-1/8.....	40
DA20-0281	46	PS07C-191	22	SA-11-10	39
DA20-0297	46	PS07C-203	22	SA-11-15	39
DA20-0312	46	PS07C-243	22	SA-11-20	39
DA20-0328	46	PS07C-280	22	SA-11-25	39
DA20-0344	46	PS08C-094*	22	SA11-3/16.....	40
DA20-0359	46	PS08C-122*	22	SA11-3/32.....	40
DA20-0375	46	PS08C-162*	22	SA-11-30	39
DA20N	48	PS08C-203*	22	SA-11-35	39
DA20N-C100	49	PS08C-243*	22	SA-11-40	39
DA20N-C35	49	PS14C-162	22	SA-11-45	39
DA20N-C40	49	PS14C-203	22	SA11-5/32.....	40
DA20N-C45	49	PS14C-243	22	SA-11-50	39
DA20N-C50	49	PS14C-303	22	SA-11-55	39
DA20N-C55	49	PS14C-373	22	SA-11-60	39
DA20N-C60	49	PS14C-406	22	SA-11-65	39
DA20N-C65	49	PS14C-443	22	SA11-7/32.....	40
DA20N-C70	49	PS14C-524	22	SA-11-70	39
DA20N-C75	49	PS18C-203*	22	SA11HW.....	70
DA20N-C80	49	PS18C-243*	22	SA11-iSET.....	47
DA20N-C85	49	PS18C-303*	22	SA11-MSET.....	47
DA20N-C90	49	PS18C-373*	22	SA11N.....	48
DA20N-C95	49	PS18C-443*	22	SA11SW.....	70
DA20-SET17	47	PS18C-514*	22	SA16-1/16.....	40
DA20-SET21	47	PS18C-609*	22	SA16-1/4.....	40
DA20-SET9	47	PS26C-303*	22	SA16-1/8.....	40
DA30-0047	46	PS26C-373*	22	SA16-10.....	39
DA30-0062	46	PS26C-443*	22	SA16-100.....	39
DA30-0078	46	PS26C-514*	22	SA-16-100-S.....	41

* Denotes "Non-Stock" item.

INDEX



<u>PART NUMBER</u>	<u>PAGE#</u>	<u>PART NUMBER</u>	<u>PAGE#</u>	<u>PART NUMBER</u>	<u>PAGE#</u>
SA16-11/32.....	40	SA16HW.....	70	SA20-7/16.....	40
SA16-13/32.....	40	SA16HWT.....	70	SA20-7/32.....	40
SA16-20.....	39	SA16-iSET.....	47	SA20-70.....	39
SA16-3/16.....	40	SA16-MSET.....	47	SA-20-70-S.....	41
SA16-3/32.....	40	SA16N.....	48	SA-20-75-S.....	41
SA16-3/8.....	40	SA16NCD.....	48	SA20-80.....	39
SA16-30.....	39	SA16SW.....	70	SA-20-80-S.....	41
SA-16-30-S.....	41	SA16-TR004.....	43	SA-20-85-S.....	41
SA-16-35-S.....	41	SA16-TR108.....	43	SA20-9/32.....	40
SA16-40.....	39	SA16-TR110.....	43	SA20-90.....	39
SA-16-40-S.....	41	SA20-1/2.....	40	SA-20-90-S.....	41
SA-16-45-S.....	41	SA20-1/4.....	40	SA-20-95-S.....	41
SA16-5/16.....	40	SA20-1/8.....	40	SA20CD-100.....	50
SA16-5/32.....	40	SA20-100.....	39	SA20CD-105.....	50
SA16-50.....	39	SA-20-100-S.....	41	SA20CD-110.....	50
SA-16-50-S.....	41	SA-20-105-S.....	41	SA20CD-115.....	50
SA-16-55-S.....	41	SA20-11/32.....	40	SA20CD-120.....	50
SA16-60.....	39	SA20-110.....	39	SA20CD-125.....	50
SA-16-60-S.....	40	SA-20-110-S.....	41	SA20CD-130.....	50
SA-16-65-S.....	40	SA-20-115-S.....	41	SA20CD-35.....	50
SA16-7/32.....	39	SA20-120.....	39	SA20CD-40.....	50
SA16-70.....	38	SA-20-120-S.....	41	SA20CD-45.....	50
SA-16-70-S.....	40	SA-20-125-S.....	41	SA20CD-50.....	50
SA-16-75-S.....	40	SA20-13/32.....	40	SA20CD-55.....	50
SA16-80.....	38	SA20-130.....	39	SA20CD-60.....	50
SA-16-80-S.....	40	SA-20-130-S.....	41	SA20CD-65.....	50
SA-16-85-S.....	40	SA20-15/32.....	40	SA20CD-70.....	50
SA16-9/32.....	39	SA20-20.....	39	SA20CD-75.....	50
SA16-90.....	38	SA20-3/16.....	40	SA20CD-80.....	50
SA-16-90-S.....	41	SA20-3/32.....	40	SA20CD-85.....	50
SA-16-95-S.....	41	SA20-3/8.....	40	SA20CD-90.....	50
SA16CD-100.....	50	SA20-30.....	39	SA20CD-95.....	50
SA16CD-35.....	50	SA-20-30-S.....	41	SA20HW.....	70
SA16CD-40.....	50	SA-20-35-S.....	41	SA20HWT.....	70
SA16CD-45.....	50	SA20-40.....	39	SA20-iSET.....	47
SA16CD-50.....	50	SA-20-40-S.....	41	SA20-MSET.....	47
SA16CD-55.....	50	SA-20-45-S.....	41	SA20N.....	48
SA16CD-60.....	50	SA20-5/16.....	40	SA20NCD.....	48
SA16CD-65.....	50	SA20-5/32.....	40	SA20-TR004.....	43
SA16CD-70.....	50	SA20-50.....	39	SA20-TR005.....	43
SA16CD-75.....	50	SA-20-50-S.....	41	SA20-TR006.....	43
SA16CD-80.....	50	SA-20-55-S.....	41	SA20-TR007.....	43
SA16CD-85.....	50	SA20-60.....	39	SA20-TR008.....	43
SA16CD-90.....	50	SA-20-60-S.....	41	SA20-TR108.....	43
SA16CD-95.....	50	SA-20-65-S.....	41	SA20-TR110.....	43

* Denotes "Non-Stock" item.

INDEX



PART NUMBER	PAGE#	PART NUMBER	PAGE#	PART NUMBER	PAGE#
SA25-1/2.....	40	SA-25-60-S.....	41	SA25SW.....	70
SA25-1/4.....	40	SA-25-65-S.....	41	SA25SWT.....	70
SA25-1/8.....	40	SA25-7/16.....	40	SA25-TR004.....	43
SA25-100.....	39	SA25-7/32.....	40	SA25-TR005.....	43
SA-25-100-S.....	40	SA25-70.....	39	SA25-TR006.....	43
SA-25-105-S.....	40	SA-25-70-S.....	41	SA25-TR007.....	43
SA25-11/32.....	40	SA-25-75-S.....	41	SA25-TR008.....	43
SA25-110.....	39	SA25-80.....	39	SA25-TR009.....	43
SA-25-110-S.....	41	SA-25-80-S.....	41	SA25-TR010.....	43
SA-25-115-S.....	41	SA-25-85-S.....	41	SA25-TR108.....	43
SA25-120.....	39	SA25-9/16.....	40	SA25-TR110.....	43
SA-25-120-S.....	41	SA25-9/32.....	40	SA25-TR202.....	43
SA-25-125-S.....	41	SA25-90.....	39	SA32-1/2.....	40
SA25-13/32.....	40	SA-25-90-S.....	41	SA32-1/4.....	40
SA25-130.....	39	SA-25-95-S.....	41	SA32-1/8.....	40
SA-25-130-S.....	41	SA25CD-100.....	50	SA32-100.....	39
SA-25-135-S.....	41	SA25CD-105.....	50	SA-32-100-S.....	41
SA25-140.....	39	SA25CD-110.....	50	SA-32-105-S.....	41
SA-25-140-S.....	41	SA25CD-115.....	50	SA32-11/16.....	40
SA-25-145-S.....	41	SA25CD-120.....	50	SA32-11/32.....	40
SA25-15/32.....	40	SA25CD-125.....	50	SA32-110.....	39
SA25-150.....	39	SA25CD-130.....	50	SA-32-110-S.....	41
SA-25-150-S.....	41	SA25CD-135.....	50	SA-32-115-S.....	41
SA-25-155-S.....	41	SA25CD-140.....	50	SA32-120.....	39
SA25-160.....	39	SA25CD-145.....	50	SA-32-120-S.....	41
SA-25-160-S.....	41	SA25CD-150.....	50	SA-32-125-S.....	41
SA25-17/32.....	40	SA25CD-155.....	50	SA32-13/32.....	40
SA25-19/32.....	40	SA25CD-160.....	50	SA32-130.....	39
SA25-20.....	39	SA25CD-35.....	50	SA-32-130-S.....	41
SA25-3/16.....	40	SA25CD-40.....	50	SA-32-135-S.....	41
SA25-3/32.....	40	SA25CD-45.....	50	SA32-140.....	39
SA25-3/8.....	40	SA25CD-50.....	50	SA-32-140-S.....	41
SA25-30.....	39	SA25CD-55.....	50	SA-32-145-S.....	41
SA-25-30-S.....	41	SA25CD-60.....	50	SA32-15/32.....	40
SA-25-35-S.....	41	SA25CD-65.....	50	SA32-150.....	39
SA25-40.....	39	SA25CD-70.....	50	SA-32-150-S.....	40
SA-25-40-S.....	41	SA25CD-75.....	50	SA-32-155-S.....	40
SA-25-45-S.....	41	SA25CD-80.....	50	SA32-160.....	38
SA25-5/16.....	40	SA25CD-85.....	50	SA-32-160-S.....	40
SA25-5/32.....	40	SA25CD-90.....	50	SA-32-165-S.....	40
SA25-5/8.....	40	SA25CD-95.....	50	SA32-17/32.....	39
SA25-50.....	39	SA25-iSET.....	47	SA32-170.....	39
SA-25-50-S.....	41	SA25-MSET.....	47	SA-32-170-S.....	41
SA-25-55-S.....	41	SA25N.....	48	SA-32-175-S.....	41
SA25-60.....	39	SA25NCD.....	48	SA32-180.....	39

* Denotes "Non-Stock" item.

INDEX



<u>PART NUMBER</u>	<u>PAGE#</u>	<u>PART NUMBER</u>	<u>PAGE#</u>	<u>PART NUMBER</u>	<u>PAGE#</u>
SA-32-180-S.....	41	SA32CD-115	50	SA32-TR012.....	43
SA-32-185-S.....	41	SA32CD-120	50	SA32-TR013.....	43
SA32-19/32.....	40	SA32CD-125	50	SA32-TR108.....	43
SA32-190.....	39	SA32CD-130	50	SA32-TR110.....	43
SA-32-190-S.....	41	SA32CD-135	50	SA32-TR202.....	43
SA-32-195-S.....	41	SA32CD-140	50	SA32-TR204.....	43
SA32-200.....	39	SA32CD-145	50	SA40-1/2.....	40
SA-32-200-S.....	41	SA32CD-150	50	SA40-1/4.....	40
SA32-21/32.....	40	SA32CD-155	50	SA40-1/8.....	40
SA32-23/32.....	40	SA32CD-160	50	SA40-1"	40
SA32-3/16.....	40	SA32CD-165	50	SA40-100.....	39
SA32-3/32.....	40	SA32CD-170	50	SA-40-100-S.....	41
SA32-3/4.....	40	SA32CD-175	50	SA-40-105-S.....	41
SA32-3/8.....	40	SA32CD-180	50	SA40-11/16.....	40
SA32-30.....	39	SA32CD-185	50	SA40-11/32.....	40
SA-32-30-S.....	41	SA32CD-190	50	SA40-110.....	39
SA-32-35-S.....	41	SA32CD-195	50	SA-40-110-S.....	41
SA32-40.....	39	SA32CD-200	50	SA-40-115-S.....	41
SA-32-40-S.....	41	SA32CD-35	50	SA40-120.....	39
SA-32-45-S.....	41	SA32CD-40	50	SA-40-120-S.....	41
SA32-5/16.....	40	SA32CD-45	50	SA40-13/32.....	40
SA32-5/32.....	40	SA32CD-50	50	SA40-130.....	39
SA32-5/8.....	40	SA32CD-55	50	SA-40-130-S.....	41
SA32-50.....	39	SA32CD-60	50	SA-40-135-S.....	41
SA-32-50-S.....	41	SA32CD-65	50	SA40-140.....	39
SA-32-55-S.....	41	SA32CD-70	50	SA-40-140-S.....	41
SA32-60.....	39	SA32CD-75	50	SA-40-140-S.....	41
SA-32-60-S.....	41	SA32CD-80	50	SA-40-145-S.....	41
SA-32-65-S.....	41	SA32CD-85	50	SA40-15/32.....	40
SA32-7/16.....	40	SA32CD-90	50	SA40-150.....	39
SA32-7/32.....	40	SA32CD-95	50	SA-40-150-S.....	41
SA32-70.....	39	SA32-iSET.....	47	SA-40-155-S.....	41
SA-32-70-S.....	41	SA32-MSET.....	47	SA40-160.....	39
SA-32-75-S.....	41	SA32N	48	SA-40-160-S.....	41
SA32-80.....	39	SA32NCD.....	48	SA-40-165-S.....	41
SA-32-80-S.....	41	SA32SW	70	SA40-17/32.....	40
SA-32-85-S.....	41	SA32SWT.....	70	SA40-170.....	39
SA32-9/16.....	40	SA32-TR004.....	43	SA-40-170-S.....	41
SA32-9/32.....	40	SA32-TR005.....	43	SA-40-175-S.....	41
SA32-90.....	39	SA32-TR006.....	43	SA40-180.....	39
SA-32-90-S.....	41	SA32-TR007.....	43	SA-40-180-S.....	41
SA-32-95-S.....	41	SA32-TR008.....	43	SA-40-185-S.....	41
SA32CD-100	50	SA32-TR009.....	43	SA40-19/32.....	40
SA32CD-105	50	SA32-TR010.....	43	SA40-190.....	39
SA32CD-110	50	SA32-TR011.....	43	SA-40-190-S.....	41

* Denotes "Non-Stock" item.

INDEX



<u>PART NUMBER</u>	<u>PAGE#</u>	<u>PART NUMBER</u>	<u>PAGE#</u>	<u>PART NUMBER</u>	<u>PAGE#</u>
SA-40-195-S.....	41	SA40-90.....	39	SA40CD-80	50
SA40-200.....	39	SA-40-90-S.....	41	SA40CD-85	50
SA-40-200-S.....	41	SA-40-95-S.....	41	SA40CD-90	50
SA-40-205-S.....	41	SA40CD-100	50	SA40CD-95	50
SA40-21/32.....	40	SA40CD-105	50	SA40-iSET.....	47
SA40-210.....	39	SA40CD-110	50	SA40-MSET.....	47
SA-40-210-S.....	41	SA40CD-115	50	SA40N	48
SA-40-215-S.....	41	SA40CD-120	50	SA40NCD.....	48
SA40-220.....	39	SA40CD-125	50	SA40SW	70
SA-40-220-S.....	40	SA40CD-130	50	SA40SWT.....	70
SA-40-225-S.....	40	SA40CD-135	50	SA40-TR004.....	43
SA40-23/32.....	39	SA40CD-140	50	SA40-TR005.....	43
SA40-230.....	39	SA40CD-145	50	SA40-TR006.....	43
SA-40-230-S.....	41	SA40CD-150	50	SA40-TR007.....	43
SA-40-235-S.....	41	SA40CD-155	50	SA40-TR008.....	43
SA40-240.....	39	SA40CD-160	50	SA40-TR009.....	43
SA-40-240-S.....	41	SA40CD-165	50	SA40-TR010.....	43
SA-40-245-S.....	41	SA40CD-170	50	SA40-TR011.....	43
SA40-250.....	39	SA40CD-175	50	SA40-TR012.....	43
SA-40-250-S.....	41	SA40CD-180	50	SA40-TR013.....	43
SA-40-255-S.....	41	SA40CD-185	50	SA40-TR014.....	43
SA40-260.....	39	SA40CD-190	50	SA40-TR015.....	43
SA-40-260-S.....	41	SA40CD-195	50	SA40-TR016.....	43
SA40-3/16.....	40	SA40CD-200	50	SA40-TR202.....	43
SA40-3/4.....	40	SA40CD-205	50	SA40-TR204.....	43
SA40-3/8.....	40	SA40CD-210	50	SA40-TR206.....	43
SA40-40.....	39	SA40CD-215	50	SA40-TR208.....	43
SA40-5/16.....	40	SA40CD-220	50	SA50-MSET.....	47
SA40-5/32.....	40	SA40CD-225	50	SA8-MSET.....	47
SA40-5/8.....	40	SA40CD-230	50	SA8SW	70
SA40-50.....	39	SA40CD-235	50	SASS16-100.....	42
SA40-60.....	39	SA40CD-240	50	SASS16-60.....	42
SA-40-60-S.....	41	SA40CD-245	50	SASS16-70.....	42
SA-40-65-S.....	41	SA40CD-250	50	SASS16-80.....	42
SA40-7/16.....	40	SA40CD-255	50	SASS16-90.....	42
SA40-7/32.....	40	SA40CD-260	50	SASS20-100.....	42
SA40-7/8.....	40	SA40CD-35	50	SASS20-60.....	42
SA40-70.....	39	SA40CD-40	50	SASS20-70.....	42
SA-40-70-S.....	41	SA40CD-45	50	SASS20-80.....	42
SA-40-75-S.....	41	SA40CD-50	50	SASS20-90.....	42
SA40-80.....	39	SA40CD-55	50	SASS25-100.....	42
SA-40-80-S.....	41	SA40CD-60	50	SASS25-110.....	42
SA-40-85-S.....	41	SA40CD-65	50	SASS25-120.....	42
SA40-9/16.....	40	SA40CD-70	50	SASS25-130.....	42
SA40-9/32.....	40	SA40CD-75	50	SASS25-140.....	42

* Denotes "Non-Stock" item.

INDEX



<u>PART NUMBER</u>	<u>PAGE#</u>	<u>PART NUMBER</u>	<u>PAGE#</u>	<u>PART NUMBER</u>	<u>PAGE#</u>
SASS25-150.....	42	SG10-0641	44	SG15-0672	45
SASS25-160.....	42	SG10-0656	44	SG15-0688	45
SASS32-160.....	42	SG10-0672	44	SG15-0703	45
SASS32-170.....	42	SG10-0688	44	SG15-0719	45
SASS32-180.....	42	SG10-0703	44	SG15-0734	45
SASS32-190.....	42	SG10-0719	44	SG15-0750	45
SASS32-200.....	42	SG10-0734	44	SG15-0765	45
SASS40-180.....	42	SG10-0750	44	SG15-0781	45
SASS40-190.....	42	SG10-0765	44	SG15-0796	45
SASS40-200.....	42	SG10-0781	44	SG15-0812	45
SG10-0094	44	SG10-0796	44	SG15-0828	45
SG10-0109	44	SG10-0812	44	SG15-0843	45
SG10-0125	44	SG10-0828	44	SG15-0859	45
SG10-0141	44	SG10-0843	44	SG15-0875	45
SG10-0156	44	SG10-0859	44	SG15-0890	45
SG10-0172	44	SG10-0875	44	SG15-0906	45
SG10-0187	44	SG10-0890	44	SG15-0921	45
SG10-0203	44	SG10-0906	44	SG15-0937	45
SG10-0219	44	SG10-0921	44	SG15-0953	45
SG10-0234	44	SG10-0937	44	SG15-0968	45
SG10-0250	44	SG10-0953	44	SG15-0984	45
SG10-0266	44	SG10-0968	44	SG15-1000	45
SG10-0281	44	SG10-0984	44	SG15-1015	45
SG10-0297	44	SG10-1000	44	SG15-1031	45
SG10-0312	44	SG10HW	70	SG15-1047	45
SG10-0328	44	SG10HWT	70	SG15-1062	45
SG10-0344	44	SG10N.....	48	SG15-1078	45
SG10-0359	44	SG10-SET15	47	SG15-1094	45
SG10-0375	44	SG10-SET21	47	SG15-1109	45
SG10-0391	44	SG10-SET30	47	SG15-1125	45
SG10-0406	44	SG10-SET41	47	SG15-1141	45
SG10-0422	44	SG10-SET59	47	SG15-1156	45
SG10-0437	44	SG10SW.....	70	SG15-1172	45
SG10-0453	44	SG10SWT	70	SG15-1187	45
SG10-0469	44	SG15-0500	45	SG15-1203	45
SG10-0484	44	SG15-0516	45	SG15-1219	45
SG10-0500	44	SG15-0531	45	SG15-1234	45
SG10-0516	44	SG15-0547	45	SG15-1250	45
SG10-0531	44	SG15-0562	45	SG15-1266	45
SG10-0547	44	SG15-0578	45	SG15-1281	45
SG10-0562	44	SG15-0594	45	SG15-1297	45
SG10-0578	44	SG15-0609	45	SG15-1312	45
SG10-0594	44	SG15-0625	45	SG15-1328	45
SG10-0609	44	SG15-0641	45	SG15-1344	45
SG10-0625	44	SG15-0656	45	SG15-1359	45

* Denotes "Non-Stock" item.

INDEX



<u>PART NUMBER</u>	<u>PAGE#</u>	<u>PART NUMBER</u>	<u>PAGE#</u>	<u>PART NUMBER</u>	<u>PAGE#</u>
SG15-1375	45	TMS-02116.....	89	TMS-361-025-2	82
SG15-1391	45	TMS-02118.....	89	TMS-361-037-1	82
SG15-1406	45	TMS-02120.....	89	TMS-361-037-2	82
SG15-1422	45	TMS-02151.....	89	TMS-361-050-1	82
SG15-1437	45	TMS-02153.....	89	TMS-361-050-2	82
SG15-1453	45	TMS-02216.....	89	TMS-361-062-1	82
SG15-1469	45	TMS-02217.....	89	TMS-361-062-2	82
SG15-1484	45	TMS-02218.....	89	TMS-361-075-1	82
SG15-1500	45	TMS-02219.....	89	TMS-361-075-2	82
SG15N.....	48	TMS-02225.....	89	TMS-361-100-1	82
SG15-SET17	47	TMS-02228.....	89	TMS-361-100-2	82
SG15-SET33	47	TMS-35100003.....	78	TMS-361-125-1	82
SG15-SET65	47	TMS-35100017.....	77	TMS-361-125-2	82
SG15SW.....	70	TMS-36100107.....	81	TMS-361-150-1	82
SG15SWT	70	TMS-36100108.....	81	TMS-361-150-2	82
STB-0019	65	TMS-36100109.....	81	TMS-36300001.....	80
STB-0019-BL*	65	TMS-36100110.....	81	TMS-36300003.....	81
STB-0019-SBL*	65	TMS-36100111.....	81	TMS-36300004.....	81
STB-0020	65	TMS-36100112.....	81	TMS-36300005.....	81
STB-0020-BL*	65	TMS-36100113.....	81	TMS-36300006.....	81
STB-0020-SBL*	65	TMS-36100114.....	81	TMS-36300007.....	81
STB-0021*	65	TMS-36100117.....	81		
STB-0021-BL*	65	TMS-36100118.....	81		
STB-0021-SBL*	65	TMS-36100120.....	82		
TF-10*	71	TMS-36100122.....	82		
TF-12	71	TMS-36100123.....	82		
TF-12-ST*	71	TMS-36100124.....	82		
TF-14	71	TMS-36100125.....	82		
TF-17	71	TMS-36100127.....	82		
TF-17-ST*	71	TMS-36100173.....	82		
TF-22	71	TMS-36100175.....	82		
TF-C30-N*	71	TMS-36100175.....	82		
TF-C40-N.....	71	TMS-36100193.....	82		
TF-C50-N.....	71	TMS-36100194.....	82		
TF-C60-N*	71	TMS-36100195.....	82		
TF-H100A-N*	71	TMS-36100196.....	82		
TF-H32A-N*	71	TMS-36100197.....	82		
TF-H40A-N*	71	TMS-36100200.....	82		
TF-H50A-N*	71	TMS-36100201.....	82		
TF-H63A-N*	71	TMS-36100208.....	82		
TF-H80A-N*	71	TMS-36100210.....	82		
TFM-20*	71	TMS-36100210.....	82		
TFM-28*	71	TMS-361-018-1	82		
TFM-36*	71	TMS-361-018-2	82		
TMS-02114.....	89	TMS-361-025-1	82		

* Denotes "Non-Stock" item.