

TurnLine

TUNG T^{URN} TJET

www.tungaloy.com/us

Tungaloy Report No. 432-US

AHB
TOOLING & MACHINERY

COMPLETE METALWORKING SOLUTIONS

(800) 991-4225

www.ahbinc.com

ISO Certified

customerservice@ahbinc.com

Member IMC Group
Tungaloy
INDUSTRY 4.0

Double clamp turning & External threading toolholders with through-coolant capability



INDUSTRY 4.0
FEED the SPEED!



ACCELERATED MACHINING









TUNG *FORCE* **TURN**
ACCELERATED MACHINING



Wide line up to improve many applications and machine set ups

Optimized with two coolant jet streams to maximize productivity

DIRECT^{TUNG}TJET system

	Tube connections	Direct coolant supply
For general lathes	<p>New</p> <p>Hybrid tool</p> 	
		  <p>For VDI (DIN 69880) & PSC adapter</p>
For small lathes		  <p>Machines for direct system : L20 & D25</p>
Features	<ul style="list-style-type: none"> - Mountable to a variety of machine types - Flexible tube connections 	<ul style="list-style-type: none"> - No tubes needed - No chip tangling - Easy tool change-over

Double clamp turning tool holders

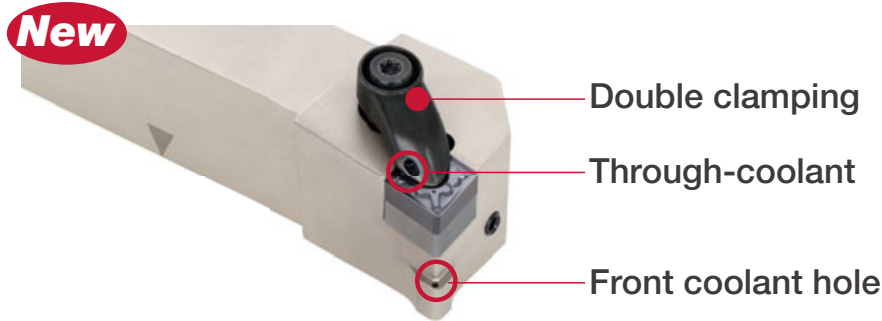

Improvement of chip control with internal coolant

S Heat-resistant alloys
(Inconel 718)

Workpiece materials : INCONEL 718
 Toolholder : **ACLNL2525X-12-CHP-MC**
 Insert : CNMG120408-HRM AH8005
 Cutting speed : $V_c = 197$ sfm
 Feed : $f = 0.006$ ipr
 Depth of cut : $a_p = 0.079$ "

TUNGTURN	TUNGTURN 14 MPa	TUNGTURN 7 MPa	Normal pressure coolant 1.5 MPa

Lever lock clamp (nozzle style) turning tool holders

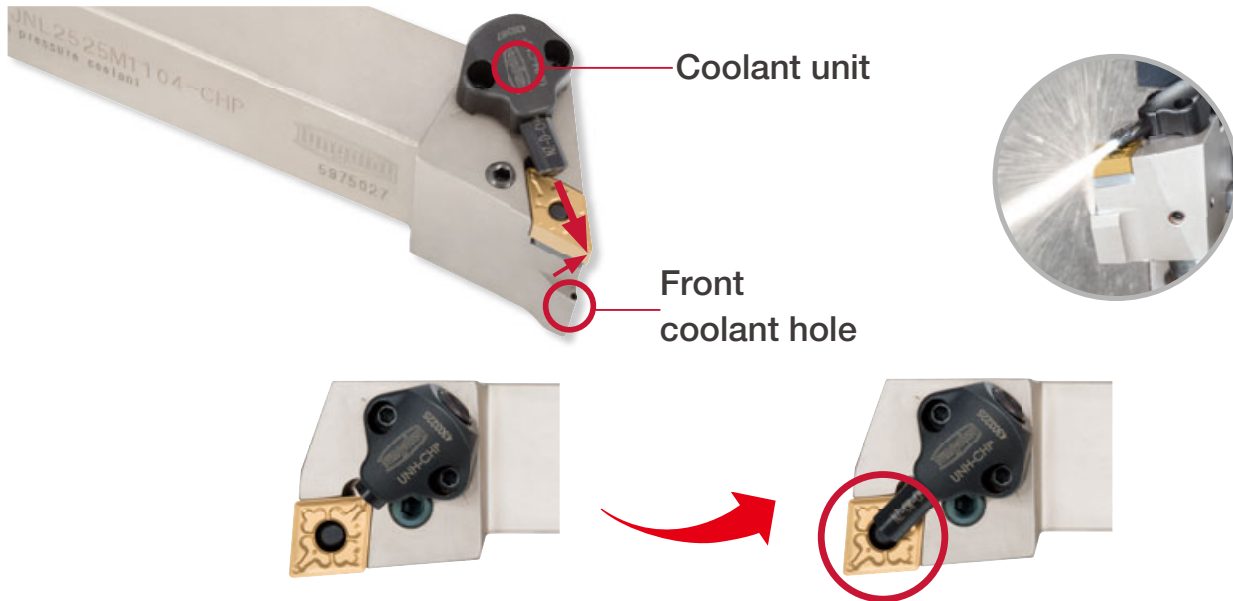

High pressure coolant disperses the cutting heat during machining, which prevents damage on cutting edges

Improved chip control with high pressure coolant

S Heat-resistant alloys (Inconel 718)

Toolholder : PCLNL124-CHP
 Insert : CNMG 432 HRM AH8005
 Cutting speed : $V_c = 197$ sfm
 Feed rate : $f = 0.008$ ipr
 Depth of cut : $a_p = 0.039$ "

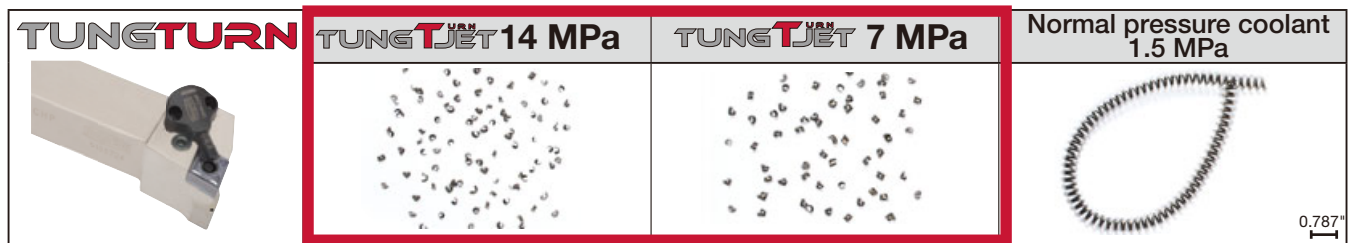

M Stainless steel: External turning (S30400)

Material : S30400
 Toolholder : JSDJ2CR083X-CHP
 Insert : DCGT 32.50.5 FN-JS SH725
 Cutting speed : $V_c = 262$ sfm
 Feed rate : $f = 0.0012$ ipr
 Depth of cut : $a_p = 0.059$ "
 Coolant type : Oil

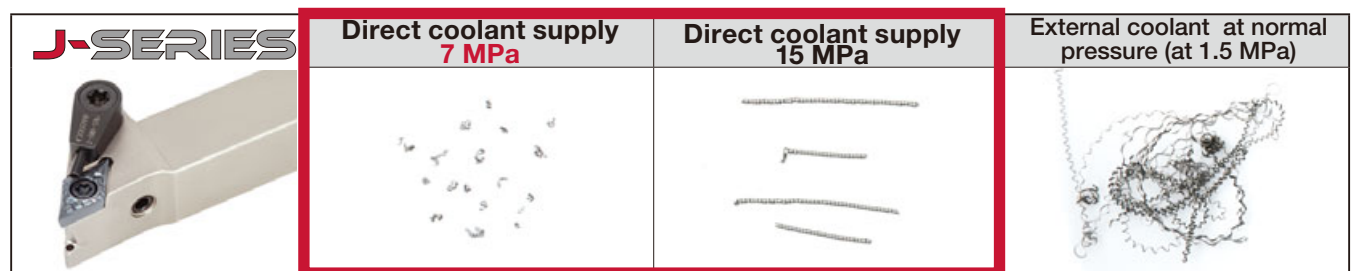

Drastically improved tool life with internal coolant

S Heat-resistant alloys (Inconel 718)

Workpiece materials : INCONEL 718
 Toolholder : ACLNL12-4-CHP-MC
 Insert : CNMG 432 HRM AH8005
 Cutting speed : $V_c = 197$ sfm
 Feed : $f = 0.006$ ipr
 Depth of cut : $a_p = 0.079$



TUNGTURN

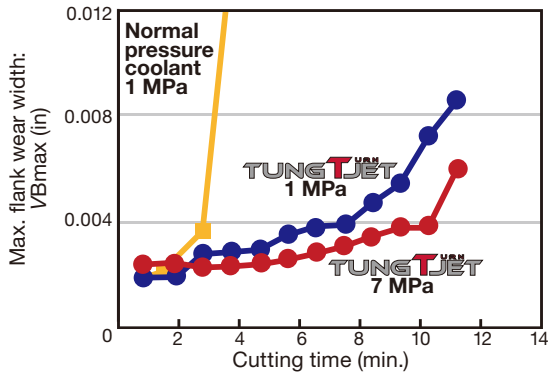

After machining for 4 min.

TUNGTURN (7 MPa)

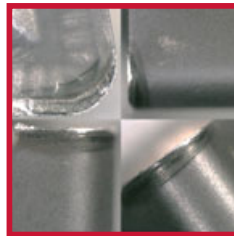

TUNGTURN (1 MPa)

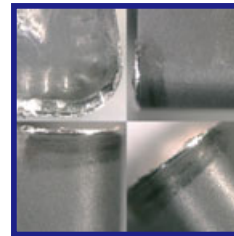

External coolant (1 MPa)



M Stainless steel: External turning (S30400)

Material : S30400
 Holder : JSDJ2CR083X-CHP
 Insert : DCGT 32.50.5 FN-JS SH725
 Cutting speed : $V_c = 656$ sfm
 Feed rate : $f = 0.004$ ipr
 Depth of cut : $a_p = 0.020$ "
 Coolant type : Oil



J-SERIES

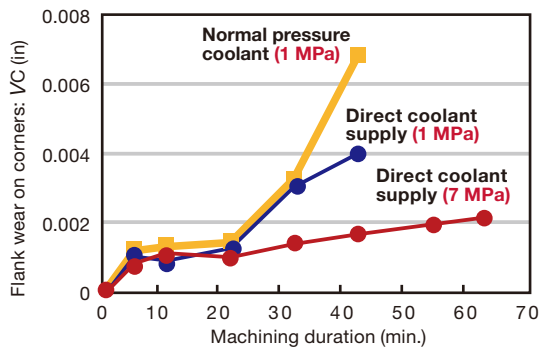

After machining for 40 min.

Direct coolant supply (7 MPa)

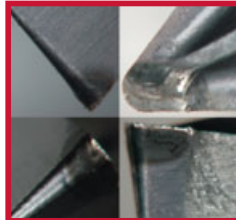

Direct coolant supply (1 MPa)

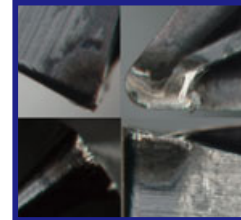



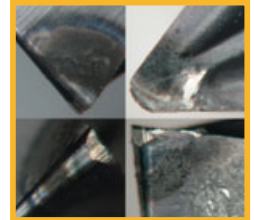







External coolant at normal pressure (1 MPa)



TUNGTURN

TUNGALOY

Sereis	Direct connections		Tube connections		TUNGCAP
	For general lathe	For small lathe	For general lathe	For small lathe	For general machining
New ISO ETURN TUNGTURN 	Shank size : 0.750", 1.000" 16X16 20X20	-	Shank size : 0.750", 1.000" 20X20	-	PSC size : C4 C5 C6
	P.10, 14, 17, P.22 - 23				
	Applicable adapter: VDI 20, 25, 30, 40 PSC size : C6				
	P.47 - 51				
J-SERIES  MINI FTURN 	-	Shank size : 0.500", 0.625"	-	Shank size : 0.500", 0.625"	-
	-	DIRECT TJET	-	P.25 - 29	-
New TUNG M^{ODULAR} SYSTEM 	Shank size : 1.299"	-	Shank size : 0.750", 1.000"	-	PSC size : C3 C4 C5 C6
	P.30		P.34		
	Applicable adapter: VDI 20, 25, 30, 40 PSC size : C6		-		
	P.47 - 51		P.32 - 33		
TETRAMCUT  TETRAFCUT  DUOJUST CUT  TUNG CUT 	-	Shank size : 0.500", 0.625"	Shank size : 0.750", 1.000"	Shank size : 0.500" 0.787"	-
	-	DIRECT TJET	-	-	-
	-	P.36 - 38, 40 - 41	P.36, 38 - 39	P.36 - 38, 40 - 41	
	-	-	-	-	
EASYM^{ULTI}CUT 	-	-	Shank size : 1.000"	-	-
	-	-	P.43 - 45	-	-
TUNGTHREAD New 	Shank size : 20X20 25X25	Shank size : 0.500", 0.625" 12X12	Shank size : 0.500" 16X16	Shank size : 0.500" 16X16	-
	P.46	P.46	P.46	P.46	-

Adapters - square shank size

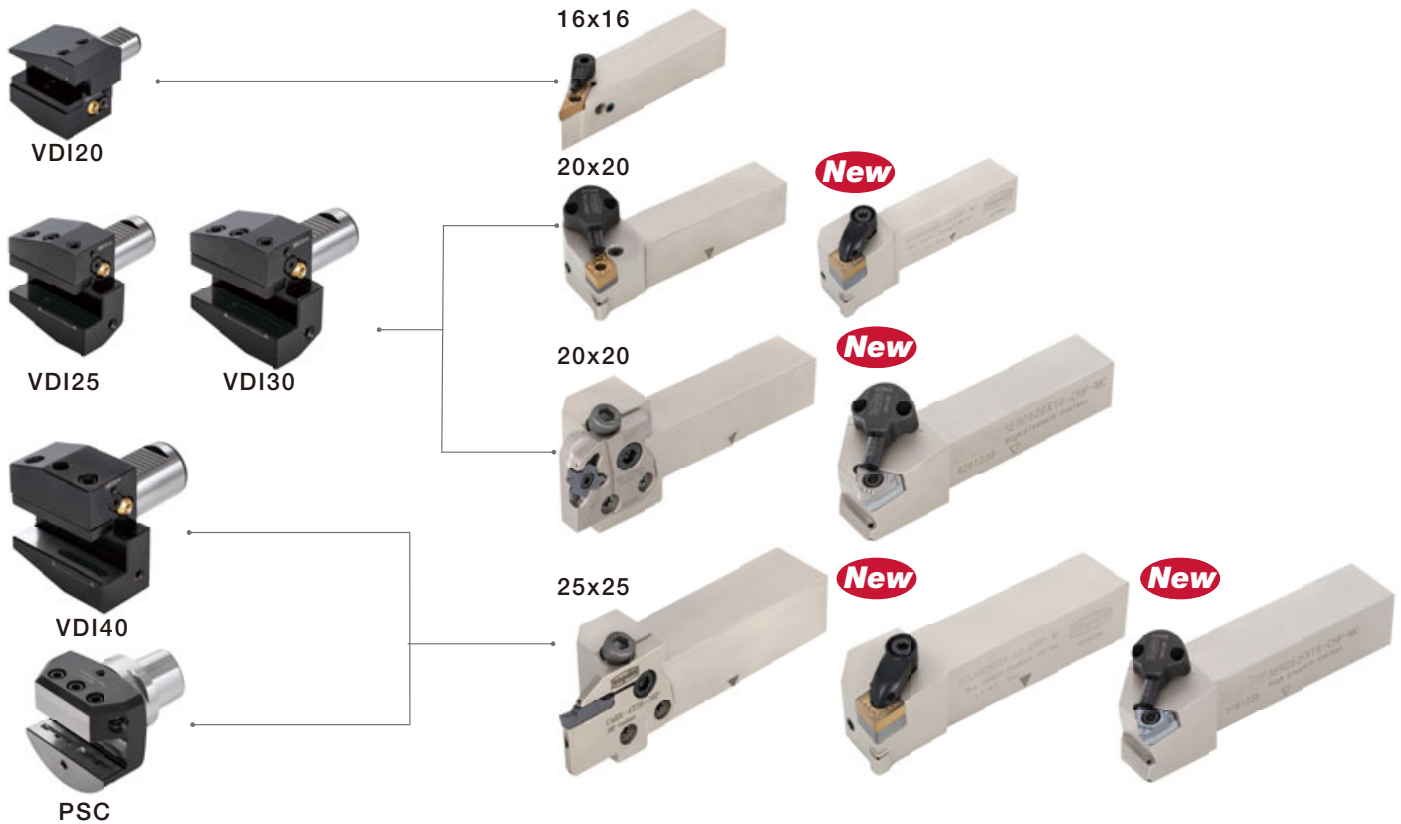

Optimized coolant designs for different insert types increases machining stability

Coolant flow rates

Insert type	Coolant hole	Coolant unit	Flow rate l/min.		
			7 MPa	10 MPa	14 MPa
		LCGL-4JC SET LCGR-4JC SET	12.5	14.8	17.5
		CU-CW-CHP	17	20	24
		CU-D-CHP	16	19	22
		CU-V-CHP	8	9.5	11
 Tools for small lathes		S-CU-CHP	4	4.8	5.7
Frontal coolant hole		-	1.8 - 2.6	2.1 - 3.4	2.5 - 3.6

New

ACLNR/L-CHP-MC

Direct connection

Tube connection

Double clamping toolholders – 95° approach angle

For negative 80° rhombic insert. High-pressure coolant capability with tube and direct connections

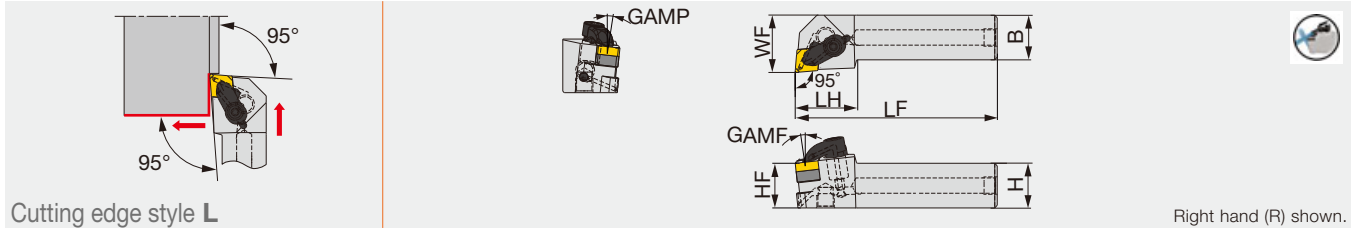

Inch	H	B	LF	LH	HF	WF	GAMP	GAMF	Insert	Torque*
ACLNR/L12-4-CHP-MC	0.750	0.750	4.500	1.378	0.750	1.000	6°	6°	CNMG 43	4
ACLNR/L16-4-CHP-MC	1.000	1.000	6.000	1.378	1.000	1.250	6°	6°	CNMG 43	4

*Torque: Recommended torque (lbf-ft) for clamping
Applicable for 14 MPa pressure coolant

SPARE PARTS

Designation	Clamp set	Shim	Shim screw	screw for tube connection	Coolant plug	O-ring	Wrench 1
ACLNL**X-12-CHP-MC	LCGL-4JCSET	RCT443	SR14-506	PLUG G1/8-6.5 TL360	SRM5X5 DIN913TL360	OR4X3NBR70	KEYL-T20
ACLNR**X-12-CHP-MC	LCGR-4JCSET	RCT443	SR14-506	PLUG G1/8-6.5 TL360	SRM5X5 DIN913TL360	OR4X3NBR70	KEYL-T20

PCLNR/L2020X-CHP-MC

Direct connection

Lever lock toolholders – 95° approach angle

For negative 80° rhombic insert. High-pressure coolant capability with bottom direct connection

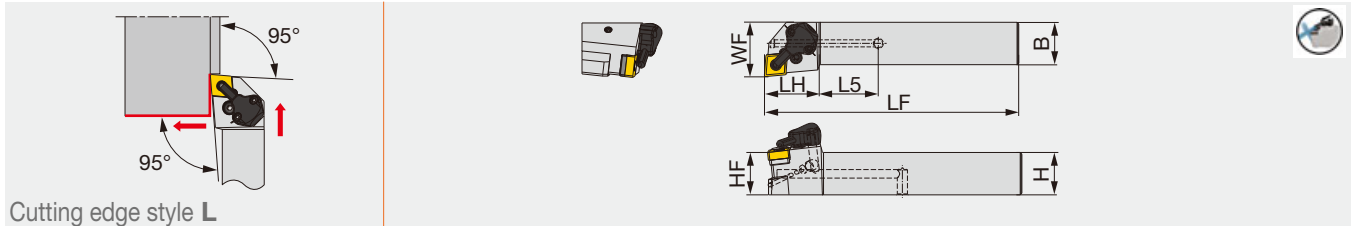

Metric	H	B	LF	LH	HF	L5	WF	Insert	Torque*
PCLNR/L2020X09-CHP-MC	20	20	97	27	20	29	25	CN**0904...	2
PCLNR/L2020X12-CHP-MC	20	20	97	27	25	29	25	CN**1204...	3

*Torque: Recommended torque (N-m) for clamping

SPARE PARTS

Designation	Shim	Spring	Lever	Spring	Spring pin	Wrench	Coolant unit	Wrench	Coolant plug	Wrench
PCLNR/L2020X09-CHP-MC	TCN323	SP3	LR3	SR117-2014	PN3-4	HW2.5	CU-CW-CHP	T-8/5	SRM5X5 DIN913TL360	-
PCLNR/L2020X12-CHP-MC	TCN443	SP4	LR4DH	SR117-2010	PN3-4L	HW2.5	CU-CW-CHP	T-8/5	SRM5X5 DIN913TL360	HW3.0

C-PCLNR/L-CHP

TUNGCAP Direct connection

Lever lock toolholders with TungCap connection – 95° approach angle.
For negative 80° rhombic insert. High-pressure coolant capability.

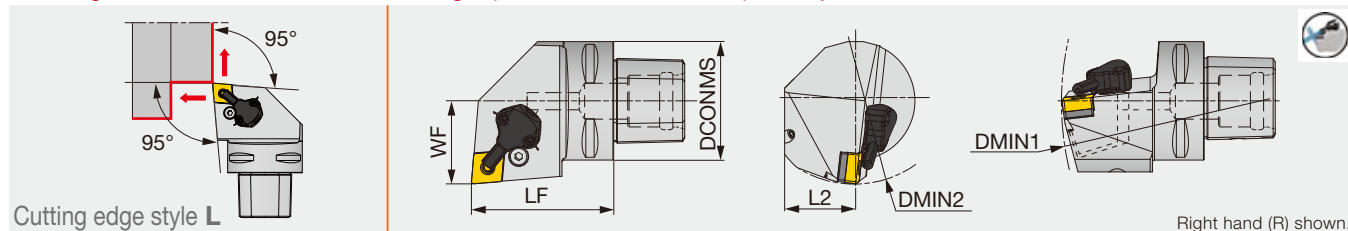

Cutting edge style L

Right hand (R) shown.

Metric	DCONMS	LF	L2	WF	DMIN1	DMIN2	RE**	Insert	Torque*
C4PCLNR/L27050-0904-CHP	40	50	25	27	140	110	0.8	CN**0904...	2
C6PCLNR/L45065-0904-CHP	63	65	41	45	190	125	0.8	CN**0904...	2
C4PCLNR/L27050-12-CHP	40	50	25	27	140	110	0.8	CN**1204...	3
C5PCLNR/L35060-12-CHP	50	60	32	35	165	110	0.8	CN**1204...	3
C6PCLNR/L45065-12-CHP	63	65	41	45	190	125	0.8	CN**1204...	3

*Torque: Recommended torque (N-m) for clamping

Applicable for 14 MPa pressure coolant

**RE: Standard corner radius

SPARE PARTS

Designation	Shim	Clamping screw	Wrench 1	Spring pin	Lever
C*PCLNR/L**0904-CHP	LSC317	LCS3	P-2.5	LSP3	LCL33
C*PCLNR/L**12-CHP	LSC42	LCS4	P-3	LSP4	LCL4

SPARE PARTS

Designation	Coolant unit	Mounting screw	Wrench 2	O-ring
C*PCLNR/L**0904-CHP	CU-CW-CHP	SRM3	T-8F	OR6.4X0.9N
C*PCLNR/L**12-CHP	CU-CW-CHP	SRM3	T-8F	OR6.4X0.9N

C-PCMNN-CHP

TUNGCAP Direct connection

Lever lock toolholder with TungCap connection.
For negative 80° rhombic insert. High-pressure coolant capability.

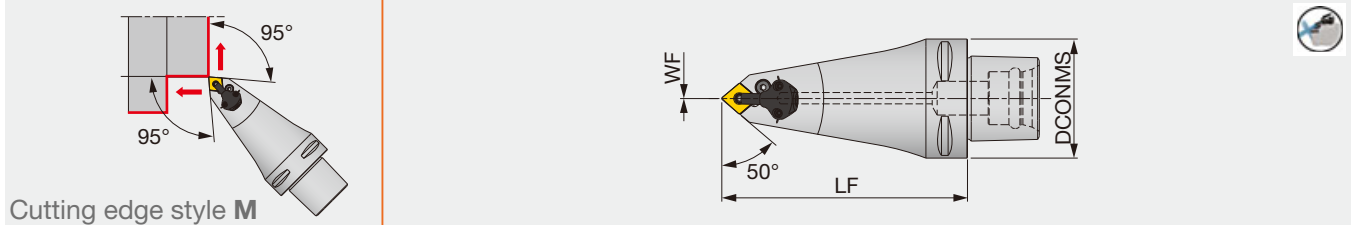

Cutting edge style **M**

Metric	DCONMS	LF	WF	RE**	Insert	Torque*
C6PCMNN00130-12-CHP	63	115	0	0.8	CN**1204...	3

*Torque: Recommended torque (N-m) for clamping
Applicable for 14 MPa pressure coolant
**RE: Standard corner radius

For external turning only.

SPARE PARTS

Designation	Shim	Clamping screw	Wrench 1	Spring pin	Lever
C6PCMNN00130-12-CHP	LSC42	LCS4	P-3	LSP4	LCL4

SPARE PARTS

Designation	Coolant unit	Mounting screw	Wrench 2	O-ring
C6PCMNN00130-12-CHP	CU-CW-CHP	SRM3	T-8F	OR6.4X0.9N

C-PCLNL-CHP

TUNGCAP Direct connection

Lever lock internal toolholder with TungCap connection – 95° approach angle.
For negative 80° rhombic insert. High-pressure coolant capability.

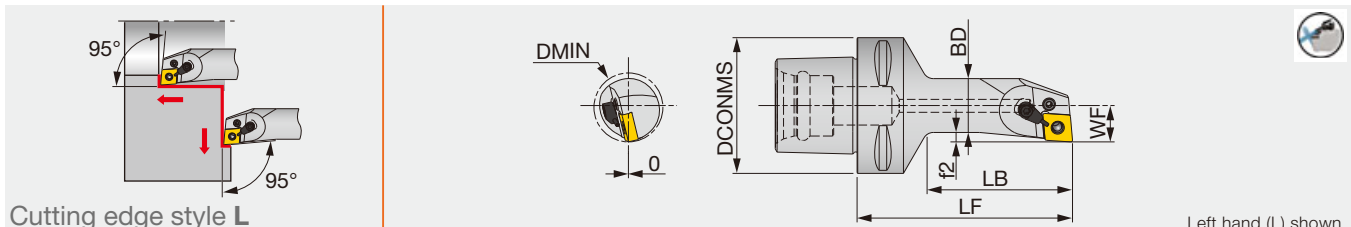

Cutting edge style **L**

Left hand (L) shown.

Metric	DMIN	DCONMS	BD	LF	LB	WF	f2	RE**	Insert	Torque*
C6PCLNL17100-12-CHP	32	63	25	100	67.5	17	4.5	0.8	CN**1204...	3

*Torque: Recommended torque (N-m) for clamping
Applicable for 14 MPa pressure coolant
**RE: Standard corner radius

SPARE PARTS

Designation	Clamping screw	Coolant unit	Wrench	Lever
C6PCLNL17100-12-CHP	LCS43	S-CU-CHP	P-2.5F	LCL43N

PCLNR/L-CHP

Tube connection

Lever lock toolholders – 95° approach angle.
For negative 80° rhombic insert. High-pressure coolant capability.

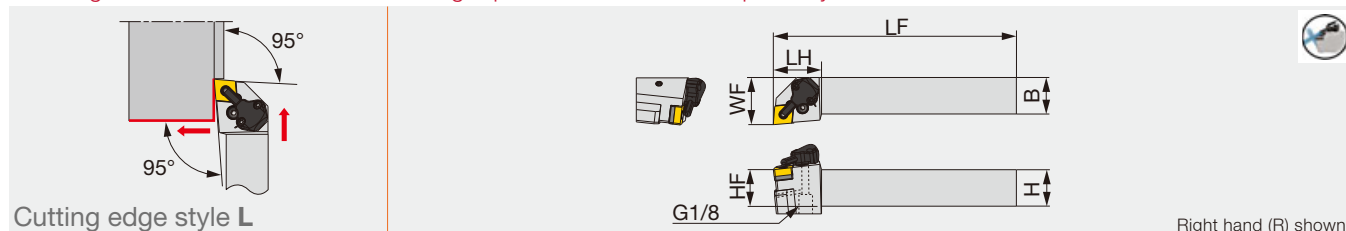

Cutting edge style L

Right hand (R) shown.

Inch	H	B	LF	LH	HF	WF	RE**	Insert	Torque*
PCLNR/L1233-CHP	0.750	0.750	4.500	1.300	0.750	1.250	0.031	CN**33...	1.48
PCLNR/L1633-CHP	1.000	1.000	6.000	1.300	1.000	1.250	0.031	CN**33...	1.48
PCLNR/L124-CHP	0.750	0.750	4.500	1.300	0.750	1.250	0.031	CN**43...	2.21
PCLNR/L164-CHP	1.000	1.000	6.000	1.300	1.000	1.250	0.031	CN**43...	2.21

*Torque: Recommended torque (lbf-ft) for clamping

**RE: Standard corner radius

SPARE PARTS

Designation	Shim	Clamping screw	Wrench 1	Spring pin	Lever
PCLNR/L12**-CHP	LSC317	LCS3	P-2.5	LSP3	LCL33
PCLNR/L16**-CHP	LSC42	LCS4	P-3	LSP4	LCL4

SPARE PARTS

Designation	Coolant unit	Mounting screw	Wrench 2	O-ring	Coolant screw	Wrench 3
PCLNR/L12**-CHP	CU-CW-CHP	SRM3	T-8F	OR6.4X0.9N	SRM4X4TL360	P-2
PCLNR/L16**-CHP	CU-CW-CHP	SRM3	T-8F	OR6.4X0.9N	SRM4X4TL360	P-2

Hose connection to the tool holder refer to page 52

New

AWLNR/L-CHP-MC

Direct connection

Tube connection

Double clamping toolholders – 95° approach angle

For negative 80° trigon insert. High-pressure coolant capability with tube and direct connections

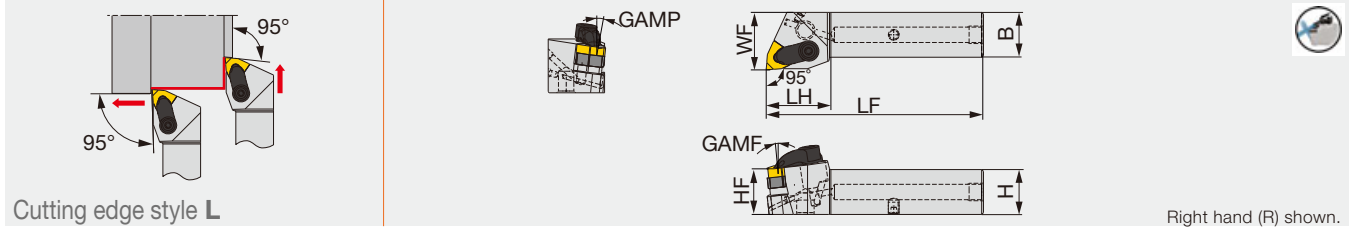

Cutting edge style L

Right hand (R) shown.

Inch	H	B	LF	LH	HF	WF	GAMP	GAMF	Insert	Torque*
AWLNR/L12-4-CHP-MC	0.750	0.75	4.173	1.417	0.750	1.000	6°	6°	WN** 43...	2.95
AWLNR/L16-4-CHP-MC	1.000	1.000	4.716	1.417	1.000	1.250	6°	6°	WN** 43...	2.95

*Torque: Recommended torque (N-m) for clamping
Applicable for 14 MPa pressure coolant

SPARE PARTS



Designation	Clamp set	Shim	Shim screw	screw for tube connection	Coolant plug	O-ring	Wrench 1
AWLNR/L12-4-CHP-MC	LCGL-4JCSET	RWT443	SR14-506	PLUGG1/8-6.5TL360	SRM5X5 DIN913TL360	OR4X3NBR70	KEYL-T20
AWLNR/L16-4-CHP-MC	LCGR-4JCSET	RWT443	SR14-506	PLUGG1/8-6.5TL360	SRM5X5 DIN913TL360	OR4X3NBR70	KEYL-T20

PWLNR/L2020X-CHP-MC

Direct connection

Lever lock toolholders – 95° approach angle.

For negative 80° trigon insert. High-pressure coolant capability with bottom direct connection

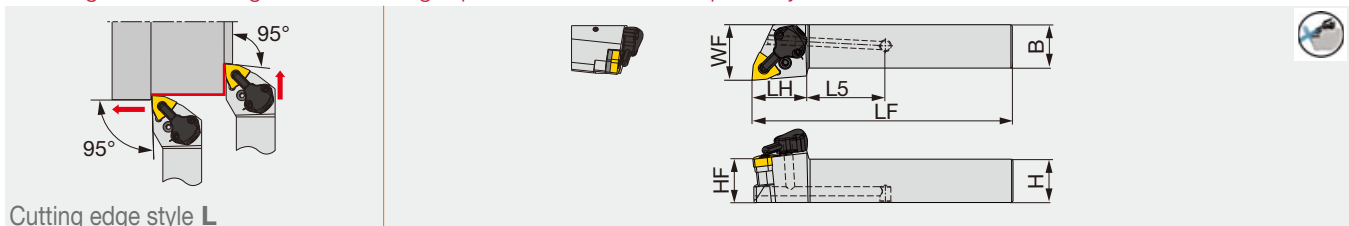

Cutting edge style L

Metric	H	B	LF	LH	HF	L5	WF	Insert	Torque*
PWLNR/L2020X06-CHP-MC	20	20	97	27	20	29	25	WN**0604...	2
PWLNR/L2020X08-CHP-MC	20	20	97	27	20	29	25	WN**0804...	3

*Torque: Recommended torque (N-m) for clamping
Applicable for 30 MPa pressure coolant

SPARE PARTS



Designation	Shim	Spring	Lever	Spring	Spring pin	Wrench	Coolant unit	Wrench	Coolant plug	Wrench
PWLNR/L2020X06-CHP-MC	TWN3	SP3	LR3	SR117-2014	PN3-4	HW2.5	CU-CW-CHP	T-8/5	SRM5X5 DIN913TL360	-
PWLNR/L2020X08-CHP-MC	TWN443	SP4	LR4DH	SR117-2010	PN3-4L	HW2.5	CU-CW-CHP	T-8/5	SRM5X5 DIN913TL360	HW3.0

C-PWLNRL/L-CHP

TUNGCAP Direct connection

Lever lock toolholders with TungCap connection – 95° approach angle.
For negative 80° trigon insert. High-pressure coolant capability.

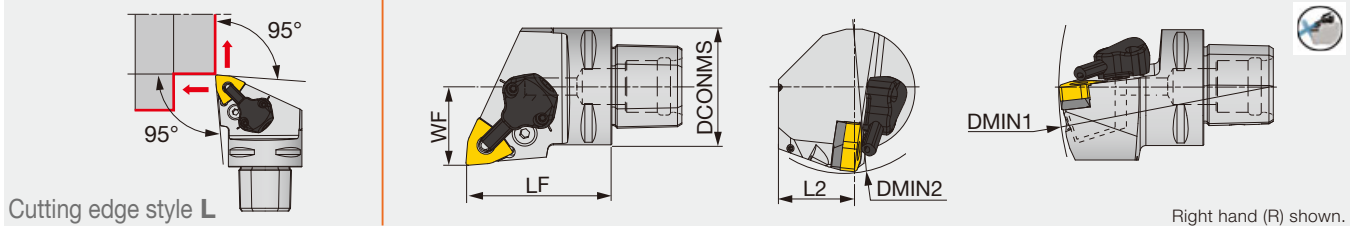

Right hand (R) shown.

Metric	DCONMS	LF	L2	WF	DMIN1	DMIN2	RE**	Insert	Torque*
C4PWLNRL/L27050-0604-CHP	40	50	25	27	140	110	0.8	WN**0604...	2
C4PWLNRL/L27050-08-CHP	40	50	25	27	140	110	0.8	WN**0804...	3
C6PWLNRL/L45065-08-CHP	63	65	41	45	190	110	0.8	WN**0804...	3

*Torque: Recommended torque (N·m) for clamping
Applicable for 14 MPa pressure coolant
**RE: Standard corner radius

SPARE PARTS

Designation	Shim	Clamping screw	Wrench 1	Spring pin	Lever
C*PWLNRL/L**0604-CHP	LSW312	LCS3	P-2.5	LSP3	LCL3
C*PWLNRL/L**-08-CHP	LSW42BL	LCS4	P-3	LSP4	LCL4

SPARE PARTS

Designation	Coolant unit	Mounting screw	Wrench 2	O-ring
C*PWLNRL/L**0604-CHP	CU-CW-CHP	SRM3	T-8F	OR6.4X0.9N
C*PWLNRL/L**-08-CHP	CU-CW-CHP	SRM3	T-8F	OR6.4X0.9N

PWLNRL/L-CHP

Tube connection

Lever lock toolholders – 95° approach angle.
For negative 80° trigon insert. High-pressure coolant capability.

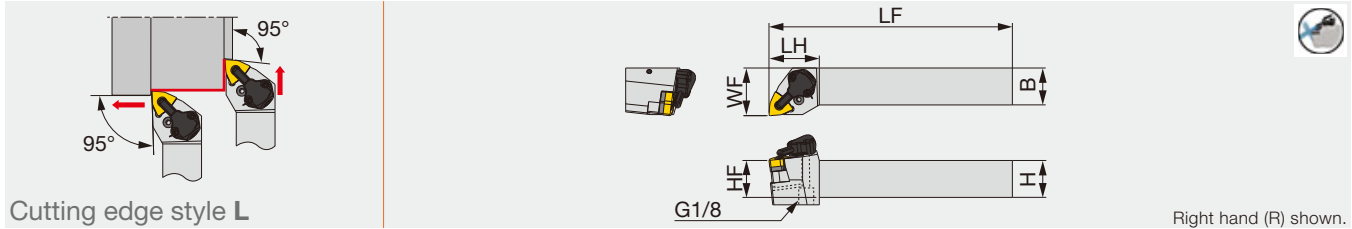

Cutting edge style L

Right hand (R) shown.

Inch	H	B	LF	LH	HF	WF	RE**	Insert	Torque*
PWLNRL/L1233-CHP	0.750	0.750	4.500	1.344	0.750	1.250	0.031	WN**33...	1.48
PWLNRL/L1633-CHP	1.000	1.000	6.000	1.344	1.000	1.250	0.031	WN**33...	1.48
PWLNRL/L124-CHP	0.750	0.750	4.500	1.344	0.750	1.250	0.031	WN**43...	2.22
PWLNRL/L164-CHP	1.000	1.000	6.000	1.344	1.000	1.250	0.031	WN**43...	2.22

*Torque: Recommended torque (lbf-ft) for clamping

**RE: Standard corner radius

SPARE PARTS

Designation	Shim	Clamping screw	Wrench 1	Spring pin	Lever
PWLNRL/L12**-CHP	LSW312	LCS3	P-2.5	LSP3	LCL3
PWLNRL/L16**-CHP	LSW42	LCS4	P-2.5	LSP4	LCL4

SPARE PARTS

Designation	Coolant unit	Mounting screw	Wrench 2	O-ring	Coolant screw	Wrench 3
PWLNRL/L12**-CHP	CU-CW-CHP	SRM3	T-8F	OR6.4X0.9N	SRM4X4TL360	P-2
PWLNRL/L16**-CHP	CU-CW-CHP	SRM3	T-8F	OR6.4X0.9N	SRM4X4TL360	P-2

Hose connection to the tool holder refer to page 52

New

ADJNR/L-CHP-MC

Direct connection

Tube connection

Double clamping toolholders – 93° approach angle

For negative 55° rhombic insert. High-pressure coolant capability with tube and direct connections

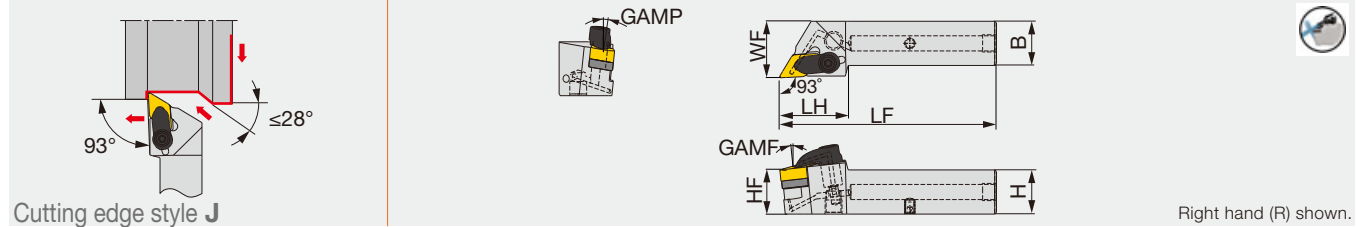

Inch	H	B	LF	LH	HF	WF	GAMP	GAMF	Insert	Torque*
ADJNR/L12-4-CHP-MC	0.750	0.750	4.331	1.575	0.750	1.000	6°	6°	DN** 43... / 44...	2.95
ADJNR/L16-4-CHP-MC	1.000	1.000	4.921	1.575	1.000	1.250	6°	6°	DN** 43... / 44...	2.95

*Torque: Recommended torque (lbf·ft) for clamping
 Use RDT443 shim when using DN 43...insert
 Use RDT433 shim when using DN** 44...insert
 Applicable for 14 MPa pressure coolant

SPARE PARTS

Designation	Clamp set	Shim	Shim screw	screw for tube connection	Coolant plug	O-ring	Wrench 1
ADJNR/L12-4-CHP-MC	LCGL-4JCSET	RDT443 RDT433	SR14-506	PLUGG1/8-6.5TL360	SRM5X5 DIN913TL360	OR4X3NBR70	KEYL-T20
ADJNR/L16-4-CHP-MC	LCGR-4JCSET	RDT443 RDT433	SR14-506	PLUGG1/8-6.5TL360	SRM5X5 DIN913TL360	OR4X3NBR70	KEYL-T20

C-PDJNR/L-CHP

TUNG CAP

Direct connection

Lever lock toolholders with TungCap connection – 93° approach angle.

For negative 55° rhombic insert. High-pressure coolant capability.

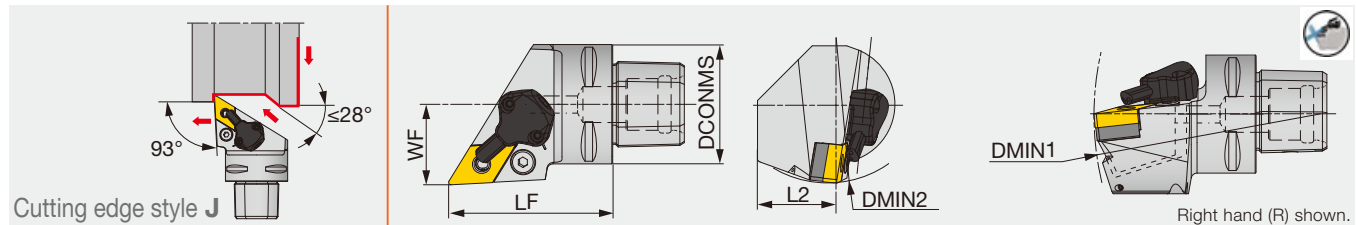

Metric	DCONMS	LF	L2	WF	DMIN1	DMIN2	RE**	Insert	Torque*
C4PDJNR/L27055-1104-CHP	40	50	27	140	140	110	0.8	DN**1104...	2
C6PDJNR/L45065-1104-CHP	63	65	45	190	190	110	0.8	DN**1104...	2
C4PDJNR/L27055-15-CHP	40	50	27	140	140	110	0.8	DN**1504(06)...	3
C5PDJNR/L35060-15-CHP	50	60	35	165	165	110	0.8	DN**1504(06)...	3
C6PDJNR/L45065-15-CHP	63	65	45	190	190	110	0.8	DN**1504(06)...	3

*Torque: Recommended torque (N-m) for clamping
 Applicable for 14 MPa pressure coolant
 **RE: Standard corner radius

SPARE PARTS

Designation	Shim	Clamping screw	Wrench 1	Spring pin	Lever
C*PDJNR/L**1104-CHP	ELSD32	LCS3	P-2.5	LSP3	LCL33L
C*PDJNR/L**-15-CHP	LSD43A	LCS4	P-3	LSP4	LCL4

Option: LSD42A (Shim for DN**1506...), LSP4S (Spring pin for DN**1506...)

SPARE PARTS

Designation	Coolant unit	Mounting screw	Wrench 2	O-ring
C*PDJNR/L**1104-CHP	CU-D-CHP	SRM3	T-8F	OR6.4X0.9N
C*PDJNR/L**-15-CHP	CU-D-CHP	SRM3	T-8F	OR6.4X0.9N

C-PVJNR/L-CHP

TUNGCAP Direct connection

Lever lock toolholders with TungCap connection – 93° approach angle.
For negative 35° or 25° rhombic insert. High-pressure coolant capability.

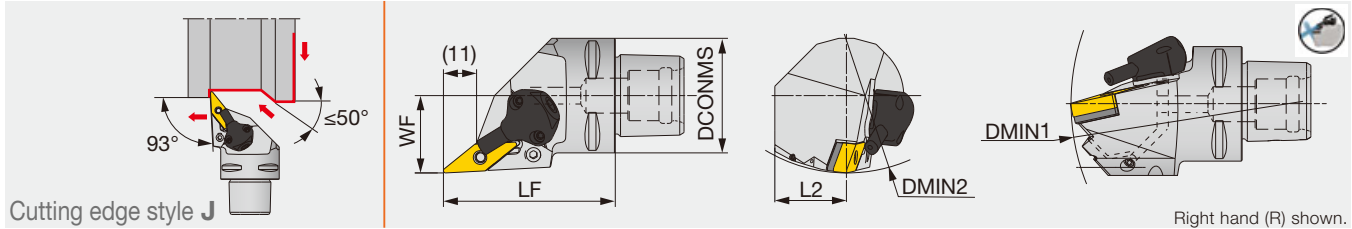

Metric	DCONMS	LF	L2	WF	DMIN1	DMIN2	RE**	Insert	Torque*
C4PVJNR/L27060-1204-CHP	40	60	20	27	140	90	0.8	VN**1204...	2
C6PVJNR/L45065-1204-CHP	63	65	31.5	45	190	81	0.8	VN**1204...	2
C4PVJNR/L27060-16-CHP	40	60	20	27	140	110	0.8	V/YN**1604...	2
C6PVJNR/L45065-16-CHP	63	65	31.5	45	190	81	0.8	V/YN**1604...	2

*Torque: Recommended torque (N-m) for clamping
Applicable for 14 MPa pressure coolant
**RE: Standard corner radius

SPARE PARTS

Designation	Shim	Clamping screw	Wrench 1	Spring pin	Lever
C*PVJNR/L*-1204-CHP	LSV212	LCS3V	P-2.5	LSP3	LCL3V
C*PVJNR/L...16-CHP	LSV317	LCS3V	P-2.5	LSP3	LCL3V

SPARE PARTS

Designation	Coolant unit	Mounting screw	Wrench 2	O-ring
C*PVJNR/L*-1204-CHP	CU-V-CHP	SRM3	T-8F	OR6.4X0.9N
C*PVJNR/L...16-CHP	CU-V-CHP	SRM3	T-8F	OR6.4X0.9N

C-PDMNL-CHP

TUNGCAP Direct connection

Lever lock toolholder with TungCap connection.
For negative 55° rhombic insert. High-pressure coolant capability.

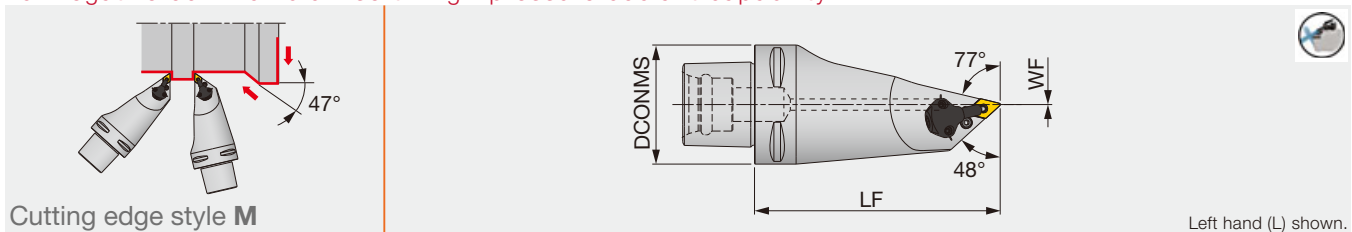

Metric	DCONMS	LF	WF	RE**	Insert	Torque*
C6PDMNL00130-1104-CHP	63	130	0	0.8	DN**1104...	2

*Torque: Recommended torque (N-m) for clamping
Applicable for 14 MPa pressure coolant
**RE: Standard corner radius

For external turning only.

SPARE PARTS

Designation	Shim	Clamping screw	Wrench 1	Spring pin	Lever
C6PDMNL00130-1104-CHP	ELSD32	LCS3	P-2.5	LSP3	LCL33L

SPARE PARTS

Designation	Coolant unit	Mounting screw	Wrench 2	O-ring
C6PDMNL00130-1104-CHP	CU-D-CHP	SRM3	T-8F	OR6.4X0.9N

C-PDUNL-CHP

TUNGCAP Direct connection

Lever lock internal toolholder with TungCap connection – 93° approach angle.
For negative 55° rhombic insert. High-pressure coolant capability.

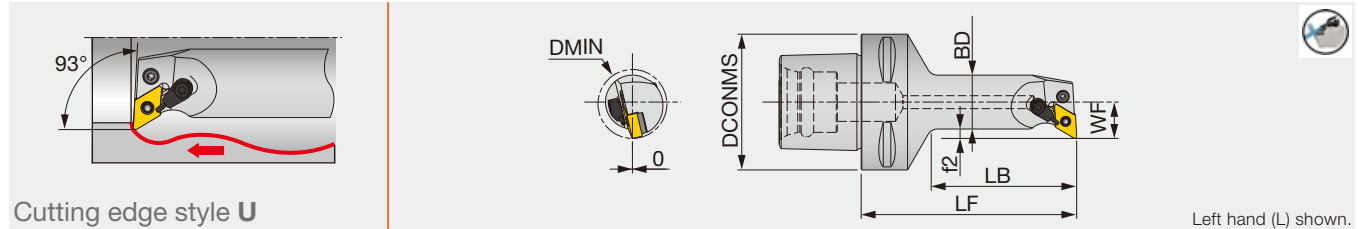

Left hand (L) shown.

Metric	DMIN	DCONMS	BD	LF	LB	WF	f2	RE**	Insert	Torque*
C6PDUNL17100-1104-CHP	32	63	25	100	67.5	17	4.5	0.8	DN**1104...	2

*Torque: Recommended torque (N-m) for clamping
Applicable for 14 MPa pressure coolant
**RE: Standard corner radius

SPARE PARTS						
Designation	Shim	Clamping screw	Coolant unit	Wrench	Spring pin	Lever
C6PDUNL17100-1104-CHP	ELSD317BL	LCS43	S-CU-CHP	P-2.5	LSP3	LCL33L

PDJNR/L-CHP

Tube connection

Lever lock toolholders – 93° approach angle.
For negative 55° rhombic insert. High-pressure coolant capability.

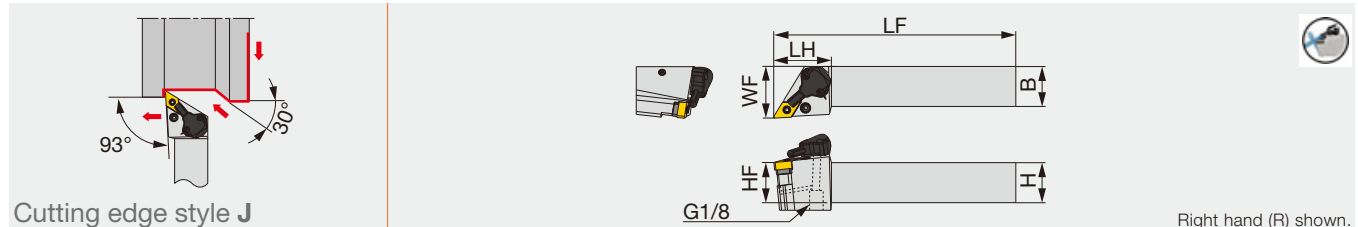

Right hand (R) shown.

Inch	H	B	LF	LH	HF	WF	RE**	Insert	Torque*
PDJNR/L1233-CHP	0.750	0.750	4.500	1.420	0.750	1.250	0.031	DN**33...	1.48
PDJNR/L1633-CHP	1.000	1.000	6.000	1.420	1.000	1.250	0.031	DN**33...	1.48
PDJNR/L124-CHP	0.750	0.750	4.500	1.420	0.750	1.250	0.031	DN**43...	2.21
PDJNR/L164-CHP	1.000	1.000	6.000	1.420	1.000	1.250	0.031	DN**43...	2.21

*Torque: Recommended torque (lbf-ft) for clamping
**RE: Standard corner radius

SPARE PARTS					
Designation	Shim	Clamping screw	Wrench 1	Spring pin	Lever
PDJNR/L12**-CHP	ELSD32	LCS3	P-2.5	LSP3	LCL33L
PDJNR/L16**-CHP	LSD43A	LCS4	P-3	LSP4	LCL4

SPARE PARTS						
Designation	Coolant unit	Mounting screw	Wrench 2	O-ring	Coolant screw	Wrench 3
PDJNR/L12**-CHP	CU-D-CHP	SRM3	T-8F	OR6.4X0.9N	SRM4X4TL360	P-2
PDJNR/L16**-CHP	CU-D-CHP	SRM3	T-8F	OR6.4X0.9N	SRM4X4TL360	P-2

Hose connection to the tool holder refer to page 52

PTGNR/L-CHP

Tube connection

Lever lock toolholders – 91° approach angle.
For negative triangle insert. High-pressure coolant capability.

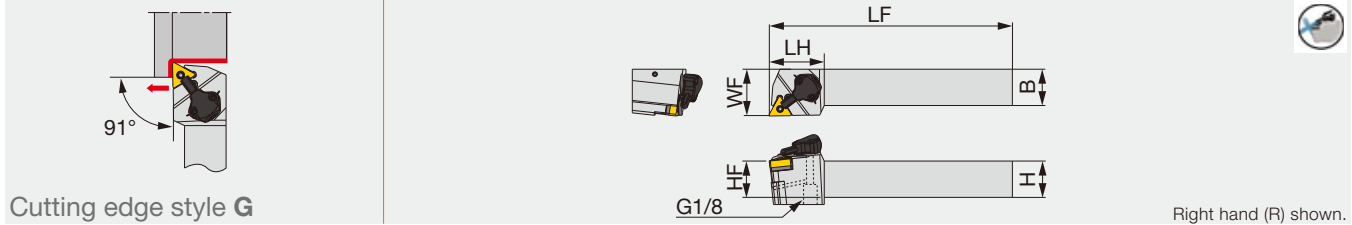

Right hand (R) shown.

Inch	H	B	LF	LH	HF	WF	RE**	Insert	Torque*
PTGNR/L1223-CHP	0.750	0.750	4.500	1.500	0.750	1.250	0.031	TN**23...	1.48
PTGNR/L1623-CHP	1.000	1.000	6.000	1.500	1.000	1.250	0.031	TN**23...	1.48
PTGNR/L123-CHP	0.750	0.750	4.500	1.500	0.750	1.250	0.031	TN**33...	1.48
PTGNR/L163-CHP	1.000	1.000	6.000	1.500	1.000	1.250	0.031	TN**33...	1.48

*Torque: Recommended torque (lb-ft) for clamping

**RE: Standard corner radius

SPARE PARTS

Designation	Shim	Clamping screw	Wrench 1	Spring pin	Lever
PTGNR/L12**-CHP	-	LCS23A	P-2.5	LSP3	LCL23
PTGNR/L16**-CHP	LST317	LCS3	P-2.5	LSP3	LCL3

SPARE PARTS

Designation	Coolant unit	Mounting screw	Wrench 2	O-ring	Coolant screw	Wrench 3
PTGNR/L12**-CHP	CU-CW-CHP	SRM3	T-8F	OR6.4X0.9N	SRM4X4TL360	P-2
PTGNR/L16**-CHP	CU-CW-CHP	SRM3	T-8F	OR6.4X0.9N	SRM4X4TL360	P-2

Hose connection to the tool holder refer to page 52

PVJNR/L-CHP

Tube connection

Lever lock toolholders – 93° approach angle.
For negative 35° or 25° rhombic insert. High-pressure coolant capability.

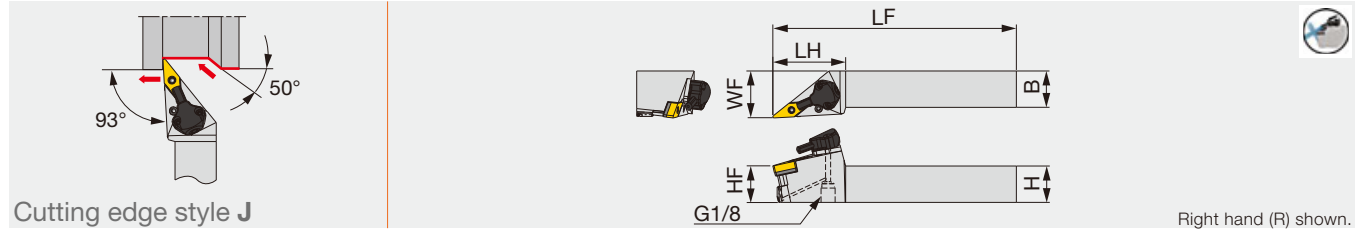

Inch	H	B	LF	LH	HF	WF	RE **	Insert	Torque*
PVJNR/L123-CHP	0.750	0.750	4.500	1.969	0.750	1.250	0.031	V/YN**33...	1.48
PVJNR/L122.33-CHP	0.750	0.750	4.500	2.000	0.750	1.250	0.031	VN** 2.33...	1.48
PVJNR/L163-CHP	1.000	1.000	6.000	1.969	1.000	1.250	0.031	V/YN**33...	1.48
PVJNR/L162.33-CHP	1.000	1.000	6.000	2.000	1.000	1.25	0.031	VN** 2.33...	1.48

*Torque: Recommended torque (lb-ft) for clamping
**RE: Standard corner radius

SPARE PARTS

Designation	Shim	Clamping screw	Wrench 1	Spring pin	Lever
PVJNR/L**-CHP	LSV317	LCS3V	P-2.5	LSP3	LCL3V

SPARE PARTS

Designation	Coolant unit	Mounting screw	Wrench 2	O-ring	Coolant screw	Wrench 3
PVJNR/L**-CHP	CU-V-CHP	SRM3	T-8F	OR6.4X0.9N	SRM4X4TL360	P-2

Hose connection to the tool holder refer to page 52

PVQNR/L-CHP

Tube connection

Lever lock toolholders – 117.5° approach angle.
For negative 35° or 25° rhombic insert. High-pressure coolant capability.

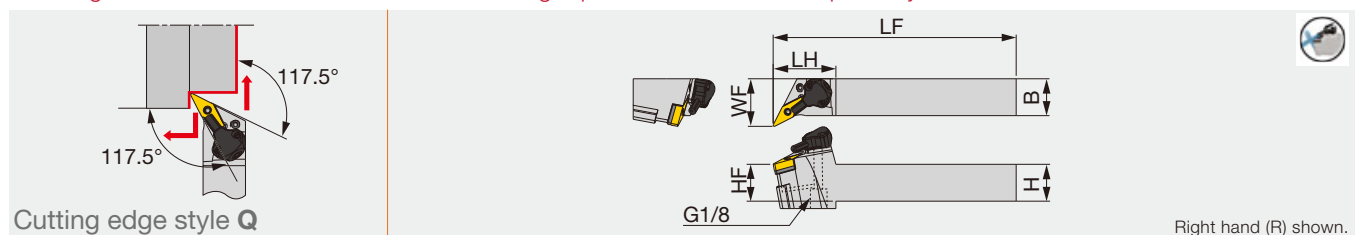

Inch	H	B	LF	LH	HF	WF	RE **	Insert	Torque*
PVQNR/L123-CHP	0.750	0.750	4.500	1.688	0.750	1.250	0.031	V/YN**33...	1.48
PVQNR/L163-CHP	1.000	1.000	6.000	1.688	1.000	1.250	0.031	V/YN**33...	1.48

*Torque: Recommended torque (lb-ft) for clamping
**RE: Standard corner radius

SPARE PARTS

Designation	Shim	Clamping screw	Wrench 1	Spring pin	Lever
PVQNR/L**-CHP	LSV317	LCS3V	P-2.5	LSP3	LCL3V

SPARE PARTS

Designation	Coolant unit	Mounting screw	Wrench 2	O-ring	Coolant screw	Wrench 3
PVQNR/L**-CHP	CU-V-CHP	SRM3	T-8F	OR6.4X0.9N	SRM4X4TL360	P-2

Hose connection to the tool holder refer to page 52

PCLCR/L1616X09S-CHP-MC

Direct connection





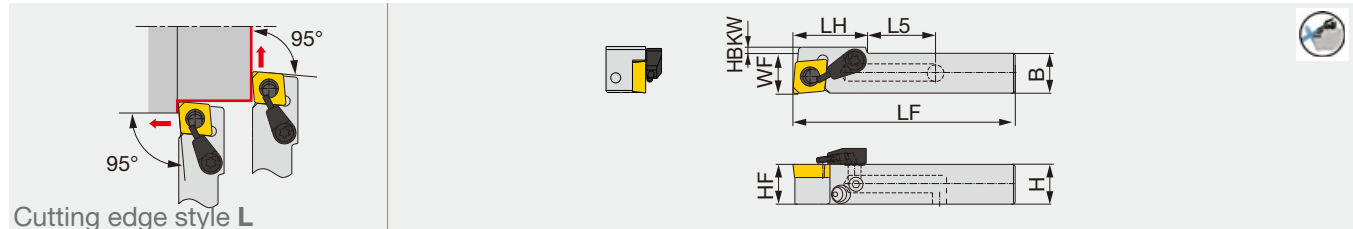

Lever lock toolholders – 95° approach angle.

For positive 80° rhombic insert. High-pressure coolant capability with bottom direct connection



Metric	H	B	LF	LH	L5	HF	WF	HBKW	Insert
PCLCR/L1616X09S-CHP-MC	16	16	71	23	17	16	16.2	-	CC**09T3

Applicable for 14 MPa pressure coolant

SPARE PARTS						
Designation	Lever	Pin	Clamping screw	Wrench	Coolant plug	Coolant unit
PCLCR/L1616X09S-CHP-MC	SLLV-3	SLPI-3	SR10400150	HW2.5/5	SR5/16UNFTL360	S-CU-CHP

PDACR/L1616X11S-CHP-MC

Direct connection





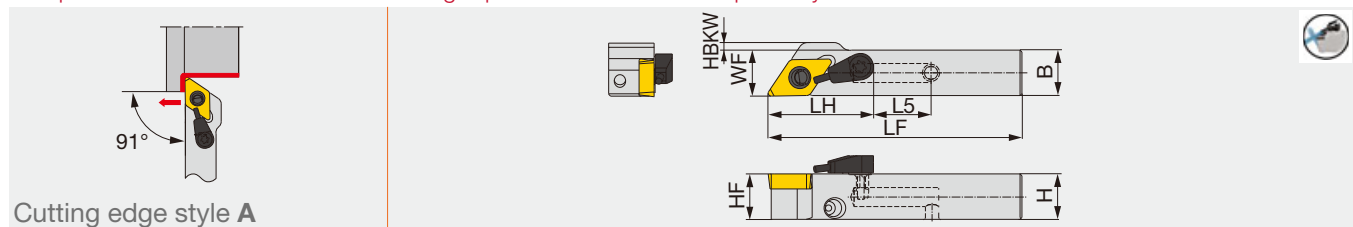

Lever lock toolholders – 91° approach angle.

For positive 55° rhombic insert. High-pressure coolant capability with bottom direct connection



Metric	H	B	LF	LH	L5	HF	WF	HBKW	Insert
PDACR/L1616X11S-CHP-MC	16	16	76	28	17	16	16.2	-	DC**11T3

Applicable for 14 MPa pressure coolant

SPARE PARTS						
Designation	Lever	Pin	Clamping screw	Wrench	Coolant plug	Coolant unit
PDACR/L1616X11S-CHP-MC	SLLV-3	SLPI-3	SR10400150	HW2.5/5	SR5/16UNFTL360	S-CU-CHP

PVACR/L1616X11S-CHP-MC

Direct connection

Lever lock toolholders – 93° approach angle.

For positive 35° or 25° rhombic insert. High-pressure coolant capability with bottom direct connection

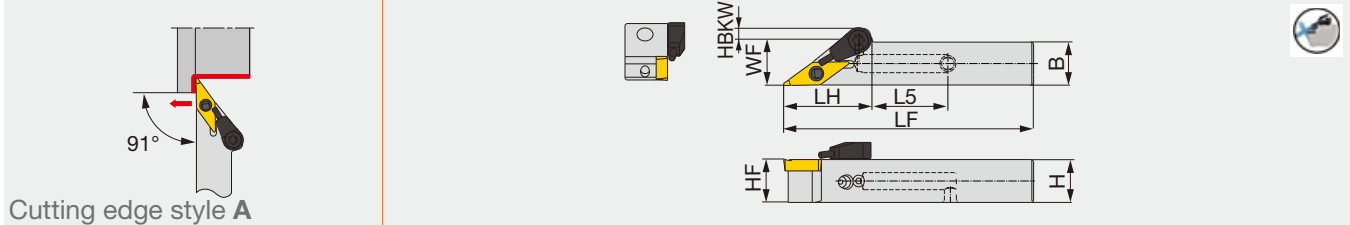

Metric	H	B	LF	LH	L5	HF	WF	HBKW	Insert
PVACR/L1616X11S-CHP-MC	16	16	73	26	16	16	16.2	-	VC**1103

Applicable for 14 MPa pressure coolant

SPARE PARTS

Designation	Lever	Pin	Clamping screw	Wrench	Coolant plug	Coolant unit
PVACR/L1616X11S-CHP-MC	SLLV-2	SL-PI-2	SR10400150	HW2.0/5	SR5/16UNFTL360	S-CU-CHP

JSCL2CR-CHP

DIRECTT^{UNE}JET Direct connection

Screw-on toolholder without offset, 95° approach angle for positive 80° rhombic inserts, high pressure coolant compatible

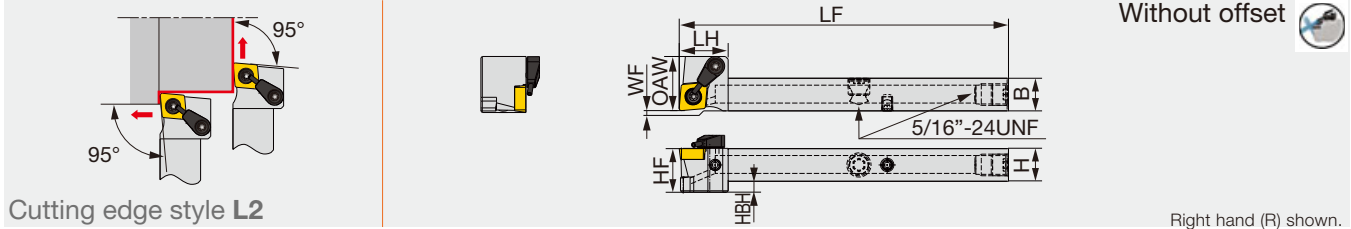

Cutting edge style L2

Right hand (R) shown.

Inch	H	B	LF	LH	HF	HBH	WF	OAW	RE	Insert	Torque*
JSCL2CR083X-CHP	0.500	0.500	4.750	0.709	0.500	0.031	0	0.787	0.008	CC**09T3...	0.89
JSCL2CR103X-CHP	0.625	0.625	4.750	0.709	0.625	0	0	0.787	0.008	CC**09T3...	0.89

*Torque: Recommended torque (lbf-ft) for clamping **RE: Standard corner radius

Note: Right-hand toolholders (R) are used with right-hand inserts (R). Left-hand toolholders (L) are used with left-hand inserts (L).

***: To be replaced with the new design

SPARE PARTS

Designation	Clamping screw	Coolant unit	Wrench	Coolant plug	Wrench	DirectJet plug	Wrench
JSCL2CR**X-CHP	CSTB-4SD	S-CU-CHP	T-8F	SR5/16UNFTL360	P-4	SSHM4-6-TB	P-2

JSDJ2CR-CHP

DIRECTT^{UNE}JET Direct connection

Screw-on toolholder without offset, 93° approach angle for positive 55° rhombic inserts, high pressure coolant compatible

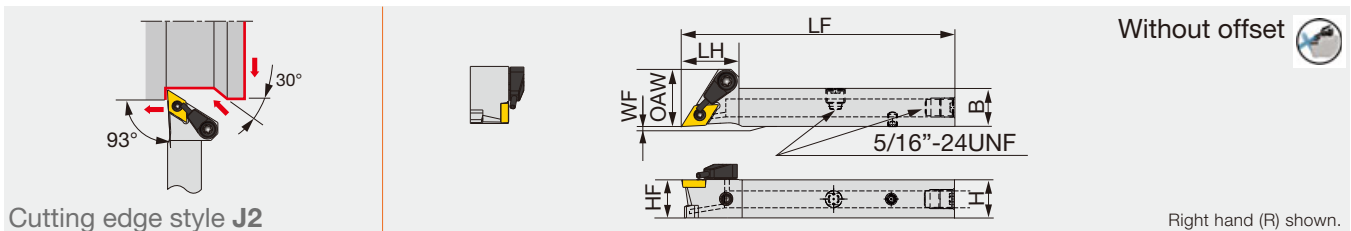

Cutting edge style J2

Right hand (R) shown.

Inch	H	B	LF	LH	HF	WF	OAW	RE	Insert	Torque*
JSDJ2CR083X-CHP	0.500	0.500	4.750	0.748	0.500	0	0.807	0.008	DC**11T3...	0.89
JSDJ2CR103X-CHP	0.625	0.625	4.750	0.748	0.625	0	0.807	0.008	DC**11T3...	0.89

*Torque: Recommended torque (lbf-ft) for clamping **RE: Standard corner radius

SPARE PARTS

Designation	Clamping screw	Coolant unit	Wrench	Coolant plug	Wrench	DirectJet plug	Wrench
JSDJ2CR**-CHP	CSTB-4SD	S-CU-CHP	T-8F	SR5/16UNFTL360	P-4	SSHM4-6-TB	P-2

JSDJ2CR/L-CHP

Tube connection

Screw-on toolholders without offset – 93° approach angle. For positive 55° rhombic insert. High-pressure coolant capability.

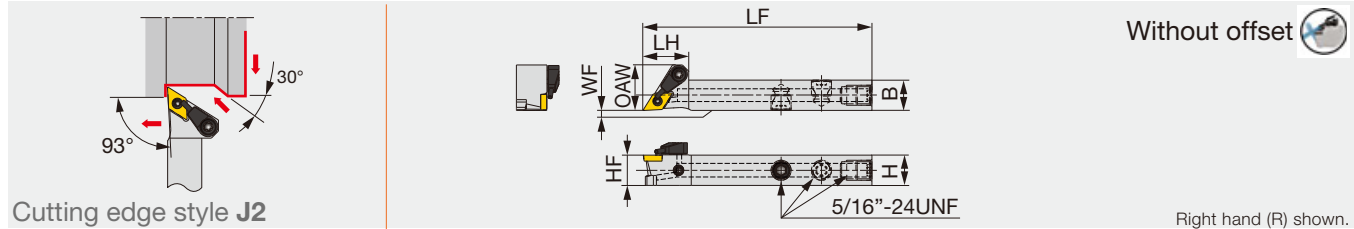

Inch	H	B	LF	LH	HF	WF	OAW	RE**	Insert	Torque*
JSDJ2CR/L082-CHP	0.500	0.500	3.344	0.710	0.500	0	0.710	0.008	DC**0702...	0.89

*Torque: Recommended torque (lbf-ft) for clamping
 **RE: Standard corner radius

SPARE PARTS

Designation	Clamping screw	Coolant unit	Wrench
JSDJ2CR/L082-CHP	CSTB-2.5	S-CU-CHP	T-8F

Hose connection to the tool holder refer to page 52

JSVJ2BR-CHP

DIRECTJET Direct connection

Screw-on toolholder without offset, 93° approach angle for positive 35° rhombic inserts, high pressure coolant compatible

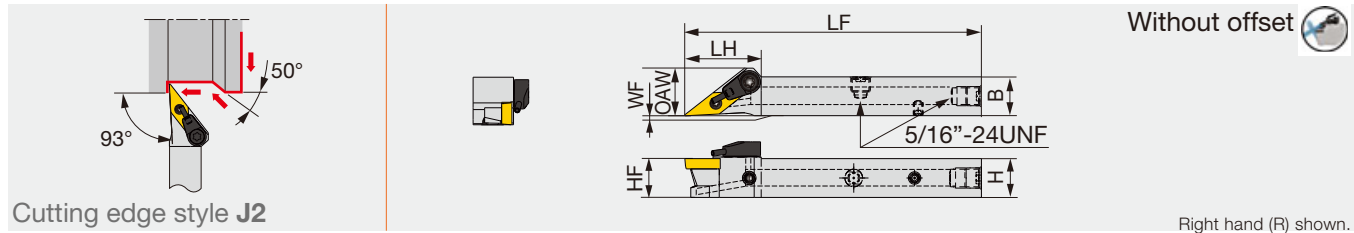

Inch	H	B	LF	LH	HF	WF	OAW	RE	Insert	Torque*
JSVJ2BR082X-CHP	0.500	0.500	4.750	0.929	0.500	0	0.575	0.008	VB**1103...	0.89
JSVJ2BR102X-CHP	0.625	0.625	4.750	0.929	0.625	0	0.625	0.008	VB**1103...	0.89
JSVJ2BR/L082-CHP	0.500	0.500	3.344	0.930	0.500	0	0.610	0.008	VB**1103...	0.89

*Torque: Recommended torque (lbf-ft) for clamping
 **RE: Standard corner radius

SPARE PARTS

Designation	Clamping screw	Coolant unit	Wrench	Coolant plug	Wrench	DirectJet plug	Wrench
JSVJ2B**-CHP	CSTB-2.5	S-CU-CHP	T-8F	SR5/16UNFTL360	P-4	SSHM4-6-TB	P-2

JSVJ2BR/L-CHP

Tube connection

Screw-on toolholder without offset – 93° approach angle. For positive 35° rhombic insert.
High-pressure coolant capability.

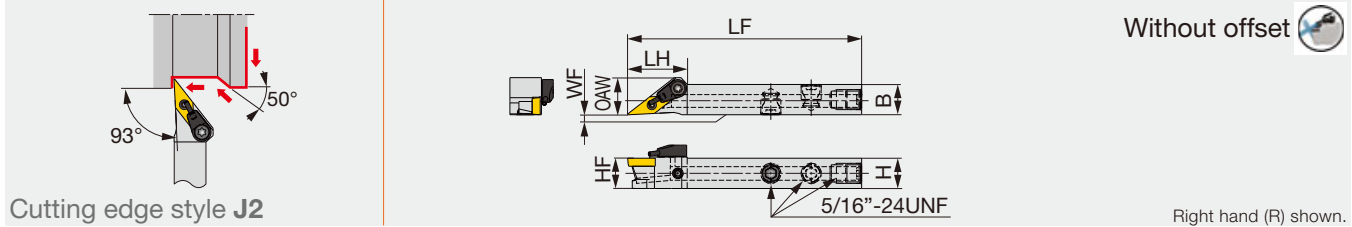

Cutting edge style **J2**

Right hand (R) shown.

Inch	H	B	LF	LH	HF	WF	OAW	RE **	Insert	Torque*
JSVJ2BR/L082-CHP	0.500	0.500	3.344	0.930	0.500	0	0.610	0.008	VB**1103...	0.9

*Torque: Recommended torque (lbf-ft) for clamping

**RE: Standard corner radius

SPARE PARTS					
Designation	Clamping screw	Coolant unit	Wrench	Coolant plug	Wrench
JSVJ2BR/L082-CHP	CSTB-2.5	S-CU-CHP	T-8F	SR5/16UNFTL360	P-4

Hose connection to the tool holder refer to page 52

JSWL2XR-CHP

DIRECTJET Direct connection

Screw-on toolholder without offset, 95° approach angle, for WXGU inserts, high pressure coolant compatible

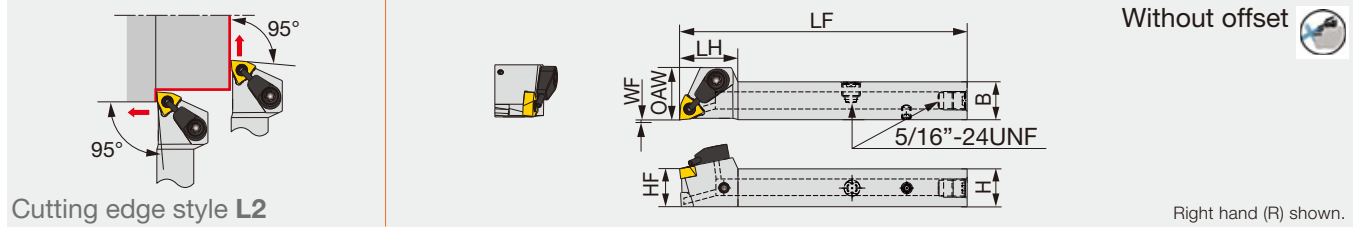

Inch	H	B	LF	LH	HF	WF	OAW	RE**	Insert	Torque*
JSWL2XR082X-CHP	0.500	0.500	4.750	0.728	0.500	0	0.650	0.008	WXGU0403**L...	0.66
JSWL2XR102X-CHP	0.625	0.625	4.750	0.728	0.625	0	0.650	0.008	WXGU0403**L...	0.66

*Torque: Recommended torque (lb-ft) for clamping **RE: Standard corner radius
Note: Right-hand toolholders (R) are used with left-hand inserts (L).

SPARE PARTS							
Designation	Clamping screw	Coolant unit	Wrench	Coolant plug	Wrench	DirectJet plug	Wrench
JSWL2XR**-CHP	SR34-514	S-CU-CHP	T-7F	SR5/16UNFTL360	P-4	SSHM4-6-TB	P-2

JSWL2XR/L-CHP

Tube connection

Screw-on toolholder without offset – 95° approach angle. For WXGU insert. High-pressure coolant capability.

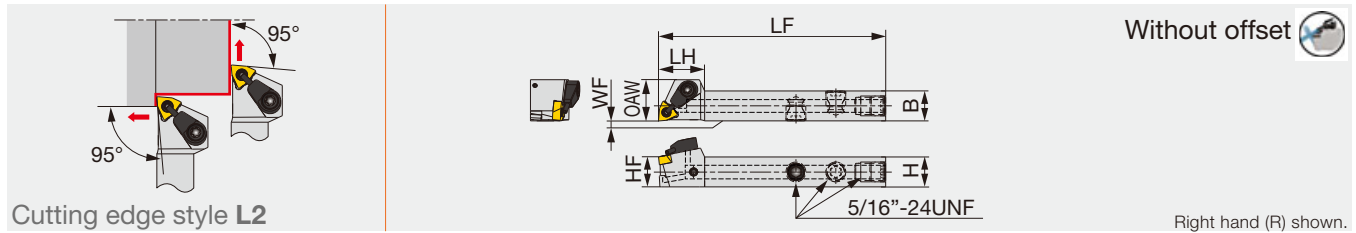

Inch	H	B	LF	LH	HF	WF	OAW	RE**	Insert	Torque*
JSWL2XR/L082-CHP	0.500	0.500	3.344	0.750	0.500	0	0.650	0.008	WXGU0403**L/R	0.66

*Torque: Recommended torque (lb-ft) for clamping **RE: Standard corner radius
Note: Right-hand toolholders (R) are used with left-hand inserts (L). Left-hand toolholders (L) are used with right-hand inserts (R).

SPARE PARTS					
Designation	Clamping screw	Coolant unit	Wrench	Coolant plug	Wrench
JSWL2XR/L082-CHP	SR34-514	S-CU-CHP	T-7F	SR5/16UNFTL360	P-4

Hose connection to the tool holder refer to page 52

JSDJ2XR-X-CHP

DIRECTJET Direct connection

Screw-on toolholder without offset, 93° approach angle, for DXGU inserts, high pressure coolant compatible

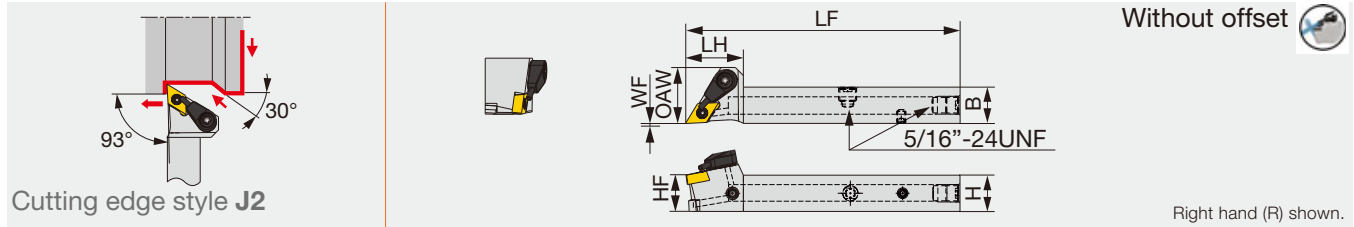

Inch	H	B	LF	LH	HF	WF	OAW	RE**	Insert	Torque*
JSDJ2XR082X-CHP	0.500	0.500	4.750	0.748	0.500	0	0.728	0.008	DXGU0703**L...	0.66
JSDJ2XR102X-CHP	0.625	0.625	4.750	0.748	0.625	0	0.728	0.008	DXGU0703**L...	0.66

*Torque: Recommended torque (lb-ft) for clamping **RE: Standard corner radius
Note: Right-hand toolholders (R) are used with left-hand inserts (L).

SPARE PARTS

Designation	Clamping screw	Coolant unit	Wrench	Coolant plug	Wrench	DirectJet plug	Wrench
JSDJ2XR**-CHP	SR34-514	S-CU-CHP	T-7F	SR5/16UNFTL360	P-4	SSHM4-6-TB	P-2

JSDJ2XR/L-CHP

Tube connection

Screw-on toolholder without offset – 93° approach angle. For DXGU insert. High-pressure coolant capability.

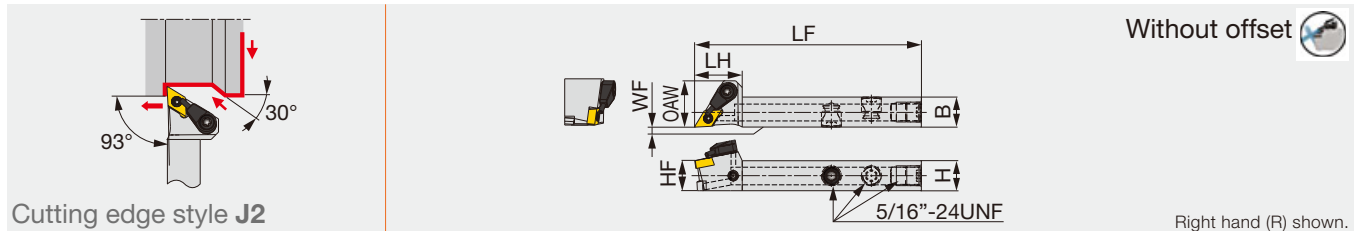

Inch	H	B	LF	LH	HF	WF	OAW	RE**	Insert	Torque*
JSDJ2XR/L082-CHP	0.500	0.500	3.344	0.750	0.500	0	0.730	0.008	DXGU0703**L/R	0.66

*Torque: Recommended torque (lb-ft) for clamping
**RE: Standard corner radius
Note: Right-hand toolholders (R) are used with left-hand inserts (L). Left-hand toolholders (L) are used with right-hand inserts (R).

SPARE PARTS

Designation	Clamping screw	Coolant unit	Wrench	Coolant plug	Wrench
JSDJ2XR/L082-CHP	SR34-514	S-CU-CHP	T-7F	SR5/16UNFTL360	P-4

Hose connection to the tool holder refer to page 52

JSVJ2XR-X-CHP

DIRECTJET Direct connection

Screw-on toolholder without offset, 93° approach angle, for VXGU inserts, high pressure coolant compatible

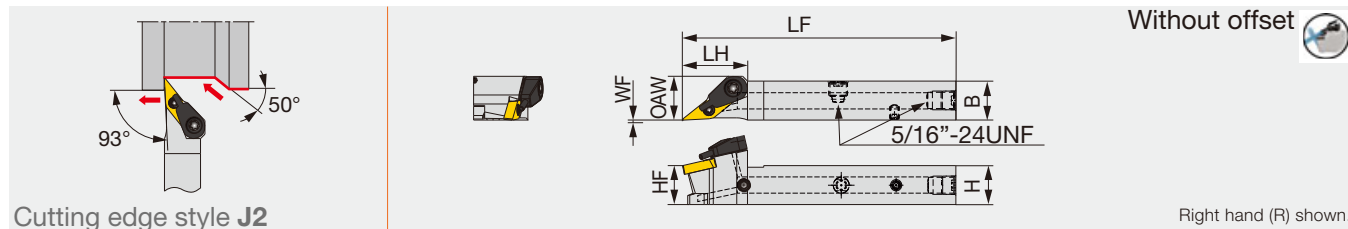

Inch	H	B	LF	LH	HF	WF	OAW	RE**	Insert	Torque*
JSVJ2XR087X-CHP	0.500	0.500	4.750	0.768	0.500	0	0.528	0.008	VXGU09T2...	0.66
JSVJ2XR107X-CHP	0.625	0.625	4.750	0.768	0.625	0	0.625	0.008	VXGU09T2...	0.66

*Torque: Recommended torque (lbf-ft) for clamping **RE: Standard corner radius
 Note: Right-hand toolholders (R) are used with left-hand inserts (L).

Designation	Clamping screw	Coolant unit	Wrench	Coolant plug	Wrench	DirectJet plug	Wrench
JSVJ2XR**-CHP	SR34-508	S-CU-CHP	T-7F	SR5/16UNFTL360	P-4	SSH4-6-TB	P-2

JSVJ2XR/L-CHP

Tube connection

Screw-on toolholder without offset – 93° approach angle. For VXGU insert. High-pressure coolant capability.

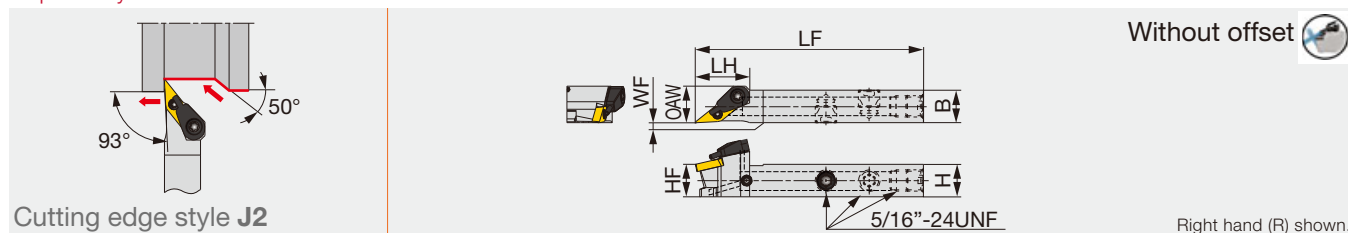

Inch	H	B	LF	LH	HF	WF	OAW	RE**	Insert	Torque*
JSVJ2XR/L087-CHP	0.500	0.500	3.344	0.787	0.500	0	0.535	0.008	VXGU09T2**L/R	0.66

*Torque: Recommended torque (lbf-ft) for clamping
 **RE: Standard corner radius
 Note: Right-hand toolholders (R) are used with left-hand inserts (L). Left-hand toolholders (L) are used with right-hand inserts (R).

Designation	Clamping screw	Coolant unit	Wrench	Coolant plug	Wrench
JSVJ2XR/L087-CHP	SR34-508	S-CU-CHP	T-7F	SR5/16UNFTL360	P-4

Hose connection to the tool holder refer to page 52

STCAR/L18-CHP

Modular blade with high pressure coolant channels

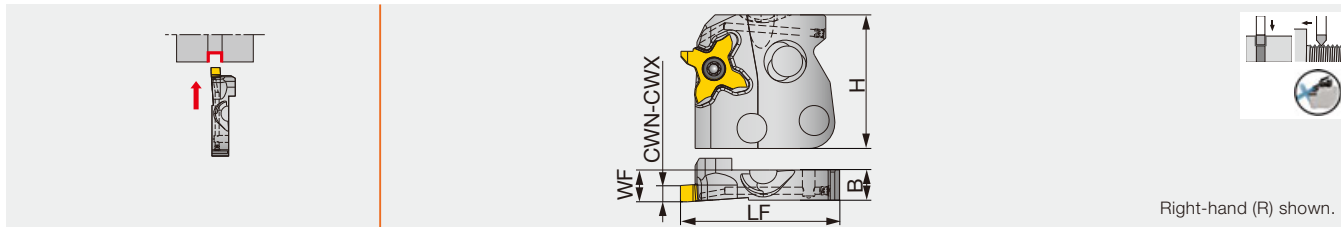

Inch	CWN	CWX	WF	H	LF	B	Insert	Torque*
STCAR/L18-CHP	0.013	0.118	0.295	1.299	1.496	0.283	TC*18...	0.89

Note: Use the right hand insert (TC*18R...) with the right hand blade (STCAR...). Use the left hand insert (TC*18L...) with the left hand blade (STCAL...).
*Torque: Recommended torque (lbf-ft) for clamping

SPARE PARTS



Designation	Clamping screw	Wrench
STCAL18-CHP	CSTC-4L100DR	T-1008/5
STCAR18-CHP	CSTC-4L100DL	T-1008/5

STCAR/L27-CHP

Modular blade with high pressure coolant channels

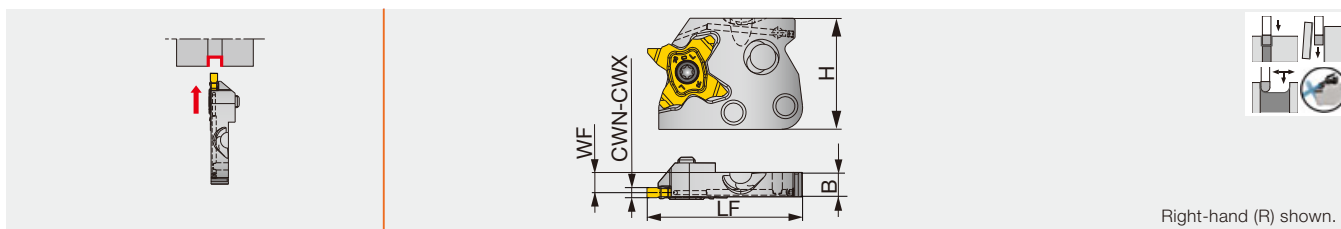

Inch	CWN	CWX	WF	H	LF	B	Insert	Torque*
STCAR/L27-CHP	0.020	0.125	0.236	1.299	1.811	0.283	TC*27...	1.84

*Torque: Recommended torque (lbf-ft) for clamping

SPARE PARTS



Designation	Screw	Wrench
STCAR27-CHP	SR16-212-01397L	T-2010/5
STCAL27-CHP	SR16-212-01397	T-2010/5

CAER/L-CHP

Modular blade for parting & grooving, with channels for high pressure coolant

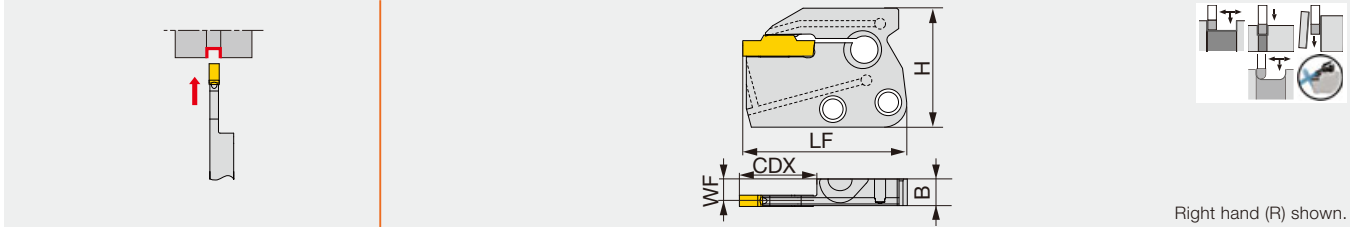

Right hand (R) shown.

Inch	CW (Inch)	CW (mm)	Seat size	CDX	H	B	LF	WF(1)
CAER/L-2T16-CHP	0.079	2	2	0.630	1.299	0.283	1.634	0.287
CAER/L-2T20-CHP	0.079	2	2	0.787	1.299	0.283	1.791	0.287
CAER/L-3T16-CHP	0.118	3	3	0.630	1.299	0.283	1.634	0.291
CAER/L-3T20-CHP	0.118	3	3	0.787	1.299	0.283	1.791	0.295
CAER/L-4T16-CHP	0.157	4	4	0.63	1.299	0.283	1.634	0.303
CAER/L-4T20-CHP	0.157	4	4	0.787	1.299	0.283	1.791	0.303
CAER/L-5T20-CHP	0.197	5	5	0.787	1.299	0.283	1.823	0.307
CAER/L-6T20-CHP	0.236	6	6	0.787	1.299	0.283	1.823	0.307

• Always use one cutting edged insert when the working depth exceeds the total insert length minus 0.059" (1.5 mm).

CHSR/L-CHP-MC

Direct connection

TungModularSystem tool holder, with hose-free direct coolant supply

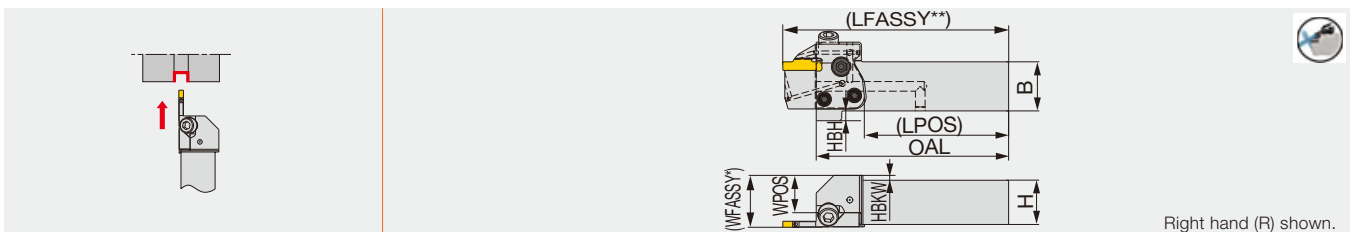

Right hand (R) shown.

Metric	H	B	OAL	LPOS	WPOS	HBKW	HBH	Blade(Optional)	Torque*
CHSR/L2020-CHP-MC	20	20	98	73.5	14	6	10	CAER/L-CHP	5
CHSR/L2525-CHP-MC	25	25	98	73.5	19	-	5	CAER/L-CHP	5

*WFASSY : shank (WPOS) + blade (WF)

**LFASSY : shank (LPOS) + blade (LF)

*Torque: Recommended torque (N·m) for clamping

Applicable for 30 MPa pressure coolant

• See pages 35 for modular blade assembly instruction

C*CHSN-CHP

TUNGCAP Direct connection

PSC body for CAER/L-CHP, with channels for high pressure coolant

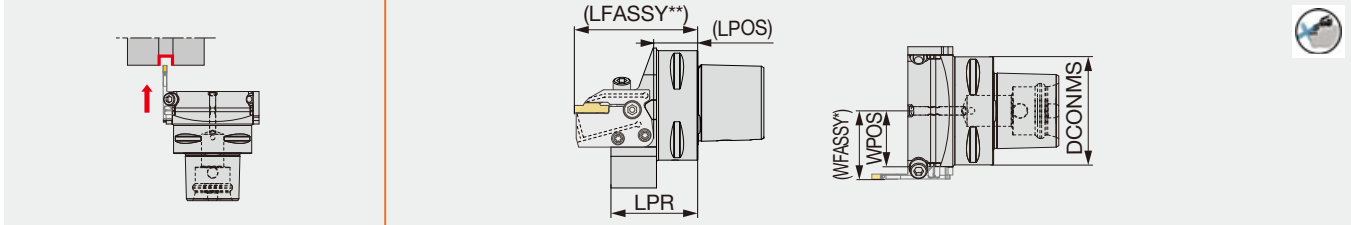

Metric	DCONMS	LPR	LPOS	WPOS	Blade(Option)	Torque*
C3CHSN19045-CHP	32	45	17.5	18.5	CAER/L-CHP	5
C4CHSN21047-CHP	40	46.5	21.5	21	CAER/L-CHP	5
C5CHSN26047-CHP	50	47	22.5	26	CAER/L-CHP	5
C6CHSN33050-CHP	63	50	24.5	32.5	CAER/L-CHP	5

*WFASSY : shank (WPOS) + blade (WF)

**LFASSY : shank (LPOS) + blade (LF)

Applicable for 30 MPa pressure coolant

*Torque: Recommended torque (N·m) for clamping

SPARE PARTS

Designation	Clamping screw	Wrench	Clamping screw	Clamping screw	Wrench	O-ring
C*CHSN*-CHP	SRM5-04451	T-20/5	SRM6X12DIN6912	SRM6X20-XT	HW5.0	OR5X1N

• See pages 35 for modular blade assembly instruction

Recommended torque

Clamping screw	Torque (N · m)
SRM5-04451	5
SRM6X12DIN6912	8.5
SRM6X20-XT	8.5

C*CHFVN-CHP

TUNGCAP Direct connection

PSC body for CAER/L-CHP, with channels for high pressure coolant

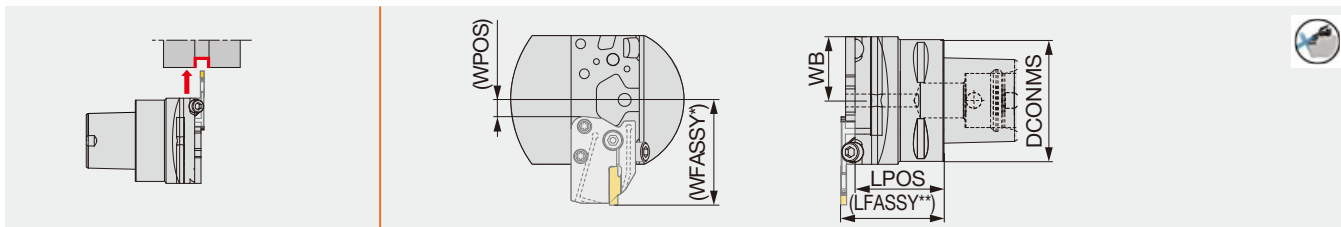

Metric	DCONMS	LPOS	WB	WPOS	Blade(Optional)	Torque*
C3CHFVN26040-CHP	32	40	26	1.5	CAER/L-CHP	5
C4CHFVN26046-CHP	40	46	26	1.5	CAER/L-CHP	5
C5CHFVN26046-CHP	50	46	26	1.5	CAER/L-CHP	5
C6CHFVN33046-CHP	63	46	33	8.5	CAER/L-CHP	5

*WFASSY : shank (WPOS) + blade (LF)

**LFASSY : shank (LPOS) + blade (WF)

Applicable for 30 MPa pressure coolant

*Torque: Recommended torque (N·m) for clamping

SPARE PARTS



Designation	Clamping screw	Wrench	Clamping screw	Clamping screw	Wrench	O-ring
C*CHFVN...-CHP	SRM5-04451	T-20/5	SRM6X12DIN6912	SRM6X20-XT	HW5.0	OR5X1N

• See pages 35 for modular blade assembly instruction

Recommended torque

Clamping screw	Torque (N · m)
SRM5-04451	5
SRM6X12DIN6912	8.5
SRM6X20-XT	8.5

CHSR/L-CHP

Tube connection

Shank for CAER/L-CHP, with channels for high pressure coolant

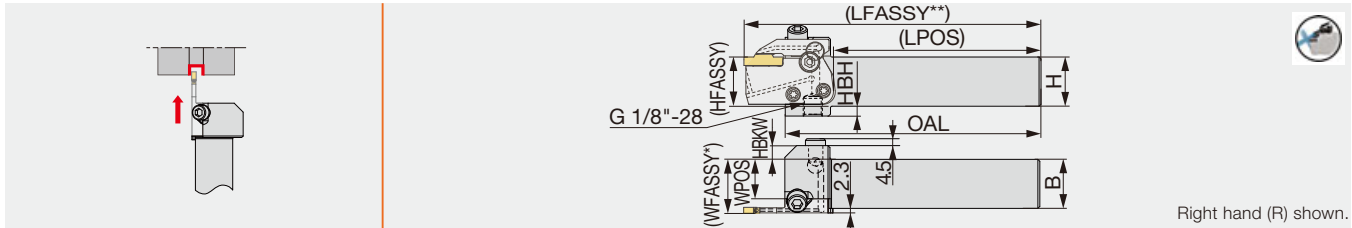

Inch	H	B	OAL	LPOS	WPOS	HBKW	HBH	Blade(Option)	Torque*
CHSR/L12-CHP	0.750	0.750	5.000	4.035	0.560	0.510	0.190	CAER/L-CHP	3.69
CHSR/L16-CHP	1.000	1.000	5.000	4.035	0.810	0.260	0.200	CAER/L-CHP	3.69

*WFASSY : shank (WPOS) + blade (WF)

**LFASSY : shank (LPOS) + blade (LF)

Applicable for 30 MPa pressure coolant

*Torque: Recommended torque (lbf-ft) for clamping

SPARE PARTS

Designation	Screw	Wrench	Clamping screw	Clamping screw	Wrench	O-ring	Plug
CHSR/L*-CHP	SRM5-04451	T-20/5	SRM6X12DIN6912	SRM6X20-XT	HW5.0	OR5X1N	PLUGG1/8ISO1179

• See page 35 for instructions on installing and removing the blade and insert
Hose connection to the tool holder refer to page 52

Recommended torque

Clamping screw	Torque (lbf-ft)
SRM5-04451	3.69
SRM6X12DIN6912	6.27
SRM6X20-XT	6.27

Combination of blade and toolholder

Toolholders	Blade			
	CAER...	CAEL...	CAFR...	CAFL...
CHSR...	●			●
CHSL...		●	●	

● : Corresponding

CHFVR/L-CHP

Tube connection

Shank for CAER/L-CHP, with channels for high pressure coolant

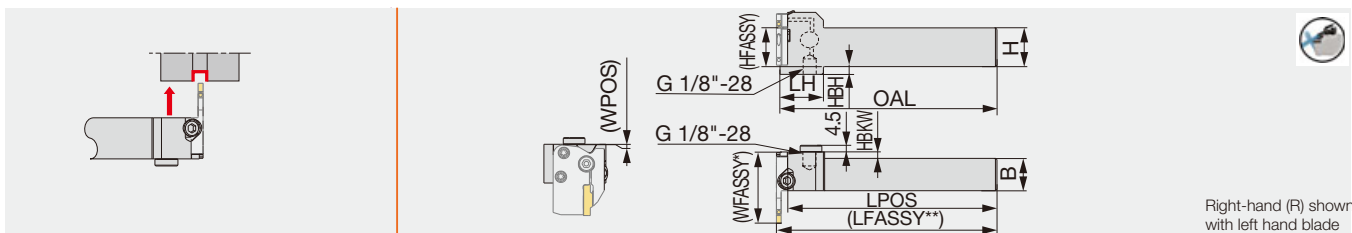

Inch	H	B	OAL	LH	LPOS	WPOS	HBKW	HBH	Blade(Option)	Torque*
CHFVR/L12-CHP	0.750	0.750	5.500	1.100	5.307	0.020	0.234	0.431	CAER/L-CHP	3.69
CHFVR/L16-CHP	1.000	1.000	5.500	1.100	5.307	0.020	0	0.200	CAER/L-CHP	3.69

*WFASSY : shank (WPOS) + blade (LF)

**LFASSY : shank (LPOS) + blade (WF)

Right-hand (R) shown with left-hand (L) blade

Applicable for 30 MPa pressure coolant

*Torque: Recommended torque (lbf-ft) for clamping

SPARE PARTS

Designation	Clamping screw	Wrench	Clamping screw	Clamping screw	Wrench	O-ring	Plug
CHFVR/L*-CHP	SRM5-04451	T-20/5	SRM6X12DIN6912	SRM6X20-XT	HW5.0	OR5X1N	PLUGG1/8ISO1179

• See pages 35 for modular blade assembly instructions
Hose connection to the tool holder refer to page 52

Recommended torque

Clamping screw	Torque (lbf-ft)
SRM5-04451	3.69
SRM6X12DIN6912	6.27
SRM6X20-XT	6.27

Combination of blade and toolholder

Toolholders	Blade			
	CAER...	CAEL...	CAFR...	CAFL...
CHFVR...		●	●	
CHFVL...	●			●

● : Corresponding

How to install and remove the blade and insert

Installing the insert

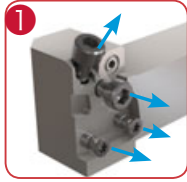

1 Remove all four screws and ensure the O rings are all in place.

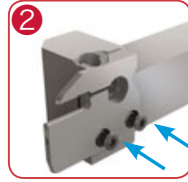

2 Place the blade in the place and tighten the two bottom clamping screws.

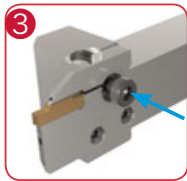

3 Place the insert in the pocket and tighten the fixing screw in the center.

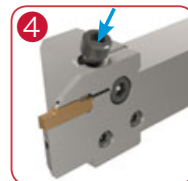

4 Place the long screw in the angular direction and tighten to clamp the insert.

Please follow the installation order as shown above. When the screws are tightened in the 4 → 3 order, the insert clamping may be insufficient and unstable.

Removing the insert

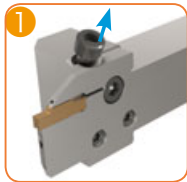

1 First loosen the long screw in the angular direction.

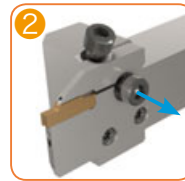

2 Loosen the Fixing screw in the center and remove the insert.

Loosing the long screw alone may not release the insert.

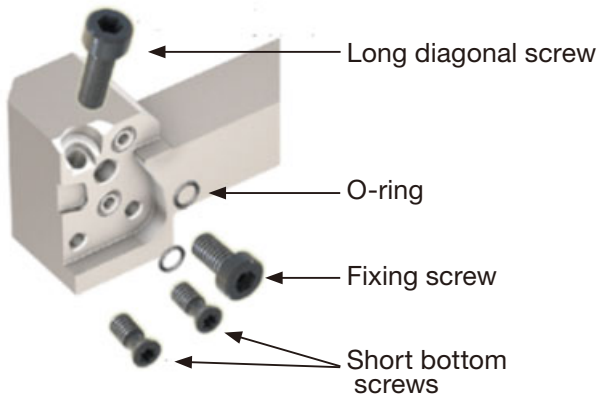

STCR/L-18-CHP

DIRECTJET Direct connection

External grooving and threading toolholder, high pressure coolant compatible

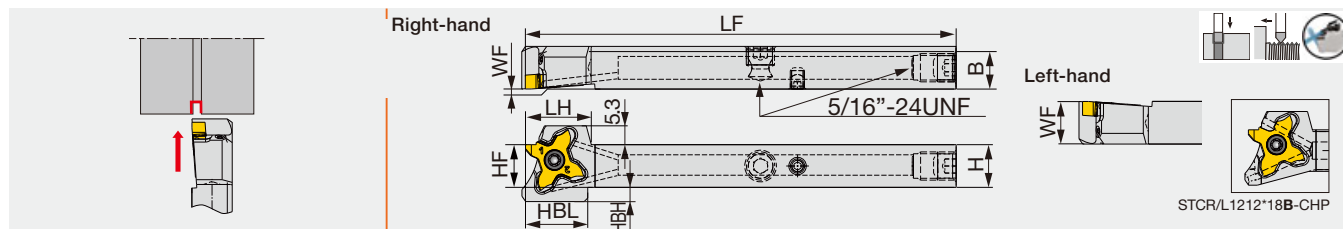

Inch	CWN	CWX	H	B	LF	LH	HBL	HF	WF	HBH	Insert	Torque*
STCR/L08X18-CHP	0.013	0.118	0.500	0.500	4.75	0.728	0.689	0.500	0/0.500	0.130	TC*18...	0.89
STCR/L10X18-CHP	0.013	0.118	0.625	0.625	4.75	0.728	-	0.625	0/0.625	-	TC*18...	0.89

Note: The right hand insert (TC*18R***) is used for the right hand toolholders (STCR***), and the left hand insert (TC*18L***) is used for the left hand toolholders (STCL***).
*Torque: Recommended torque (lbf-ft) for clamping

SPARE PARTS

Designation	Clamping screw	Wrench	Coolant plug	Wrench	DirectJet plug	Wrench
STCL**18-CHP	CSTC-4L100DR	T-1008/5	SR5/16UNFTL360	P-4	SSHM4-6-TB	P-2
STCR**18-CHP	CSTC-4L100DL	T-1008/5	SR5/16UNFTL360	P-4	SSHM4-6-TB	P-2

Groove width range : 0.013" ~ 0.118" (0.33 mm ~ 3.0 mm)

Threading pitch range : 0.013" ~ 0.118" (0.8 mm ~ 3.0 mm)

STCR/L-18-CHP

Tube connection

Threading tool - for external threading with high pressure coolant capability

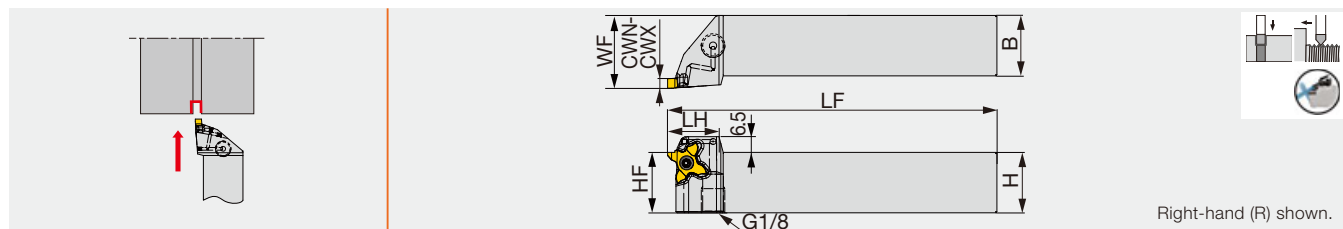

Inch	CWN	CWX	H	B	LF	LH	HBL	HF	WF	HBH	Insert	Torque*
STCR/L12-18-CHP	0.013	0.118	0.750	0.750	4.750	0.900	-	0.750	1.000	-	TC*18...	0.89
STCR/L16-18-CHP	0.013	0.118	1.000	1.000	5.500	0.900	-	1.000	1.250	-	TC*18...	0.89

Note: Use the right hand insert (TC*18R...) with the right hand toolholders (STCR...). Use the left hand insert (TC*18L...) with the left hand holder (STCL...).

*Torque: Recommended torque (lbf-ft) for clamping

SPARE PARTS

Designation	Clamping screw	Wrench
STCL**18-CHP	CSTC-4L100DR	T-1008/5
STCR**18-CHP	CSTC-4L100DL	T-1008/5

Hose connection to the tool holder refer to page 52

STCR/L-18-CHP

Tube connection

External grooving and threading toolholder. High pressure coolant capability.

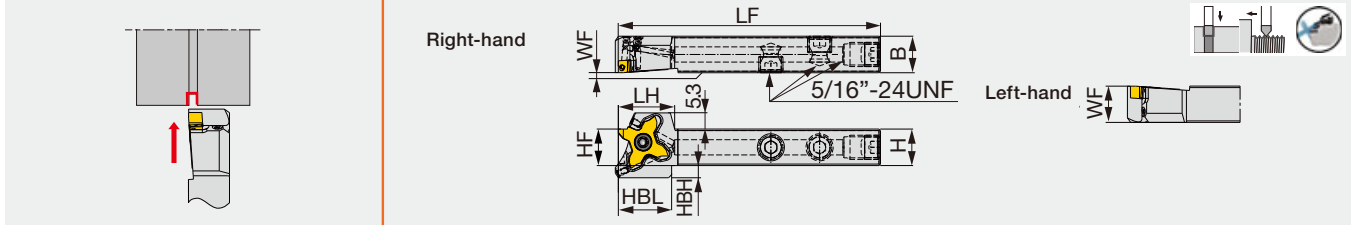

Inch	CWN	CWX	H	B	LF	LH	HBL	HF	WF	HBH	Insert	Torque*
STCR/L08F18-CHP	0.013	0.118	0.500	0.500	3.344	0.728	0.689	0.500	0/0.500	0.130	TC*18...	0.890

Note: The right hand insert (TC*18R...) is used for the right hand toolholders (STCR***), and the left hand insert (TC*18L...) is used for the left hand toolholders (STCL***).
 (1) "0/12" for the WF dimension indicates WF = 0 for the right handed tool, WF = 12 for the left handed tool.

*Torque: Recommended torque (lb-ft) for clamping

SPARE PARTS

Designation	Clamping screw	Wrench	Coolant plug	Wrench
STCL**18-CHP	CSTC-4L100DR	T-1008/5	SR5/16UNFTL360	P-4
STCR**18-CHP	CSTC-4L100DL	T-1008/5	SR5/16UNFTL360	P-4

Groove width range : 0.013" ~ 0.118" (0.33 mm ~ 3.0 mm)

Threading pitch range : 0.013" ~ 0.118" (0.8 mm ~ 3.0 mm)

Hose connection to the tool holder refer to page 52

TETRA FORCE

TUNGALOY

STCR/L-27-CHP

DIRECT TUNG JET Direct connection

Grooving and parting-off tool with DirectTung-Jet high pressure coolant capability

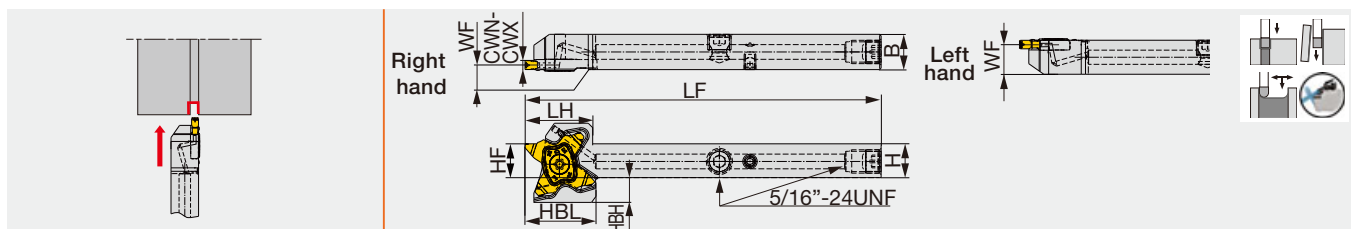

Inch	CWN	CWX	H	B	LF	LH	HF	WF(1)	HBH	HBL	insert	Torque*
STCR/L08-27-CHP	0.200	0.125	0.500	0.500	4.750	0.906	0.500	0.590/0.441	0.287	0.945	TC*27...	1.84

Note: Make sure to avoid tool interferences when used on Swiss machines

*Torque: Recommended torque (lb-ft) for clamping

(1) The above WF value is valid when an insert width of CW=3 is mounted.

STCR/L-27-CHP

Tube connection

Precision grooving tools with uniquely shaped insert with 4 cutting edges and channel for high pressure coolant supply

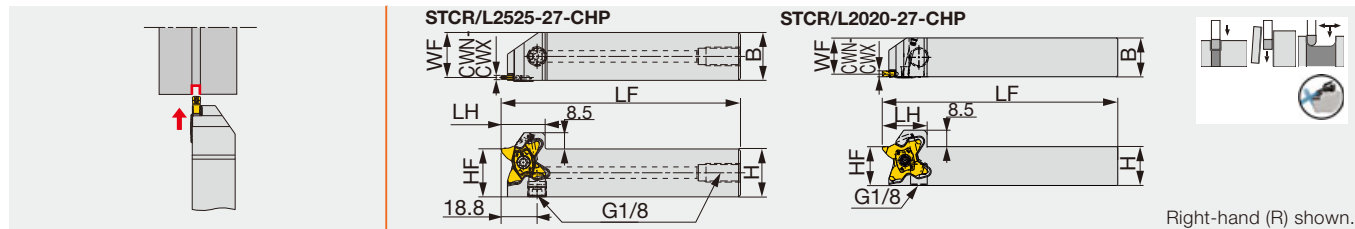

Right-hand (R) shown.

Inch	CWN	CWX	H	B	LF	LH	HF	WF	insert	Torque*
STCR/L2020-27-CHP	0.020	0.125	0.787	0.787	4.724	0.906	0.787	0.728	TC*27...	1.84
STCR/L2525-27-CHP	0.020	0.125	0.984	0.984	4.921	0.906	0.984	0.925	TC*27...	1.84

*Torque: Recommended torque (lb-ft) for clamping

SPARE PARTS



Designation	Screw	Wrench
STCR...-27-CHP	SR16-212-01397L	T-2010/5
STCL...-27-CHP	SR16-212-01397	T-2010/5

Hose connection to the tool holder refer to page 52

JCTER/L-CHP

DIRECTJET Direct connection

External grooving and parting-off toolholder, high pressure coolant compatible

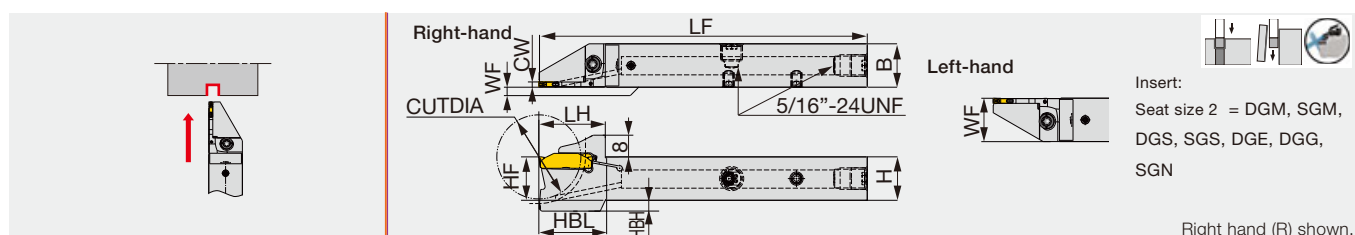

Right hand (R) shown.

Inch	CW (in)	CW (mm)	Seat size	CUTDIA	H	B	LF	LH	HBL	HF	WF (1)	HBH	Torque*
JCTER/L08X2T12-CHP	0.079	2.000	2	0.984	0.500	0.500	4.750	0.972	0.965	0.500	0/0.500	0.169	2.21
JCTER/L10X2T12-CHP	0.079	2.000	2	0.984	0.625	0.625	4.750	0.972	0.965	0.625	0/0.625	0.039	2.21
JCTER/L10X2T16-CHP	0.079	2.000	2	1.260	0.625	0.625	4.750	0.972	0.965	0.625	0/0.625	0.157	2.21
JCTER/L12X2T16-CHP	0.079	2.000	2	1.260	0.750	0.750	4.750	0.972	0.965	0.750	0/0.750	0.037	2.21

(1) "WF" value is calculated with groove width "CW" shown in the table. • CUTDIA: Max. parting off dia.

*Torque: Recommended torque (lb-ft) for clamping

SPARE PARTS



Designation	Clamping screw	Wrench	Coolant plug	Wrench	DirectJet plug	Wrench
JCTER/L...	CSHB-4-A	T-15F	SR5/16UNFTL360	P-4	SSHM4-6-TB	P-2

Parting-off width: 0.079" (2.0 mm)

See page 42 for the proper tool overhang and plug settings.

CTER/L-CHP

Tube connection

Modular blade for parting & grooving, with channels for high pressure coolant

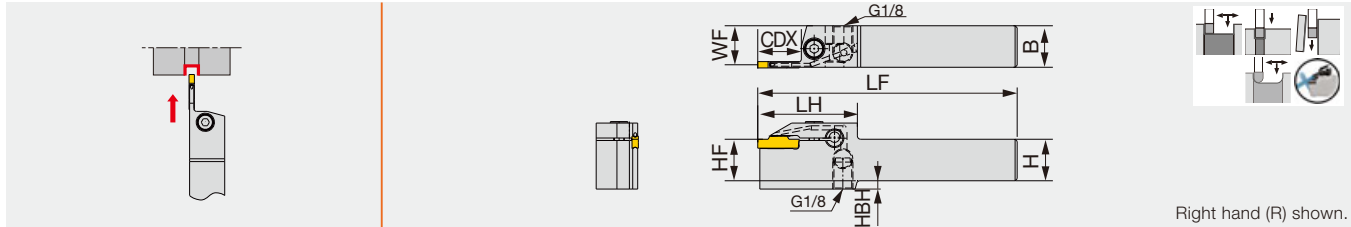

Inch	CW (in)	CW (mm)	Seat size	CDX	HF	B	H	LF	WF	HBH	LH	Torque*
CTER/L12-2T17-CHP	0.079	2	2	0.669	0.750	0.750	0.750	5.000	0.715	0.157	1.772	4.06
CTER/L16-2T17-CHP	0.079	2	2	0.669	1.000	1.000	1.000	6.000	0.965	-	1.772	4.06
CTER/L12-3T25-CHP	0.118	3	3	0.984	0.750	0.750	0.750	5.000	0.703	0.157	2.008	4.06
CTER/L16-3T25-CHP	0.118	3	3	0.984	1.000	1.000	1.000	6.000	0.953	-	2.008	4.06
CTER/L16-4T25-CHP	0.157	4	3	0.984	1.000	1.000	1.000	6.000	0.941	-	2.170	5.90
CTER/L16-5T32-CHP	0.197	5	4	1.260	1.000	1.000	1.000	6.000	0.924	-	2.323	5.90
CTER/L16-6T32-CHP	0.236	6	5	1.260	1.000	1.000	1.000	6.000	0.905	0.276	2.441	8.85

- Always use one cutting edged insert when the working depth exceeds the total insert length minus 0.059" (1.5 mm).
- *Torque: Recommended torque (lb-ft) for clamping

SPARE PARTS



Designation	Clamping screw	Wrench
CTER/L2020-2T17-CHP	CM5x0.8x20-A	P-4
CTER/L2525-2T17-CHP	CM5x0.8x25-A	P-4
CTER/L2020-3T20-CHP	CM5x0.8x20-A	P-4
CTER/L2525-3T20-CHP	CM5x0.8x25-A	P-4
CTER/L2525-3T25-CHP	CM5x0.8x25-A	P-4
CTER/L2525-4T25-CHP	CM6x1x25-A	P-5
CTER/L2525-5T20-CHP	CM6x1x25-A	P-5
CTER/L2525-6T20-CHP	CM8x1.25x25-A	P-6

Hose connection to the tool holder refer to page 52

JSXXR/L-CHP

DIRECTJET Direct connection

Parting and threading toolholder, high pressure coolant compatible

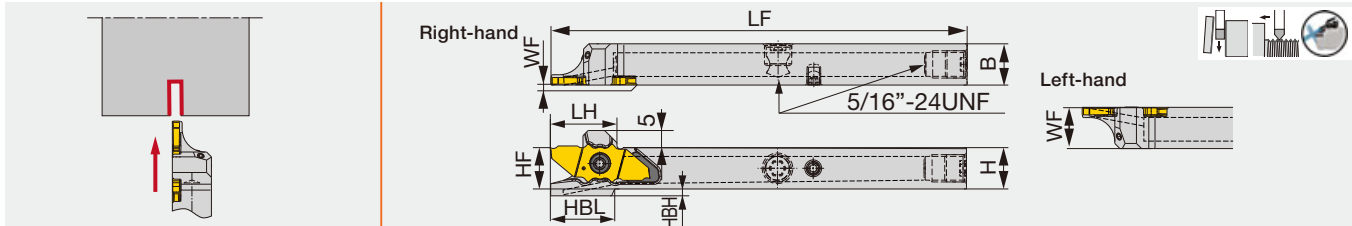

Inch	CW	H	B	WF	LF*	HF	HBH	LH	HBL	Insert	Torque*
JSXXL083X-CHP	0.039 - 0.079	0.500	0.500	0.492	4.75	0.500	0.051	0.764	0.736	JX*G06..., 12..., 16..., 20...	0.89
JSXXR103X-CHP	0.039 - 0.079	0.625	0.625	0.008	4.75	0.625	-	0.764	-	JX*G06..., 12..., 16..., 20...	0.89

*Torque: Recommended torque (lbf-ft) for clamping

**LF (Functional Length) LH (Head Length), and HBL (Head-bottom Offset Length) values shown above are true with JXPG16... insert. LF, LH, and HBL will all be 0.079" shorter than the above values with JX*G12... and JXPG20... inserts, and 0.157" shorter for JXPG06... insert.

Note: Use the right-hand insert (JX*G**R...) for a right-hand holder (JSXXR...); the left-hand insert (JX*G**L...) for a left-hand holder (JSXXL...).

SPARE PARTS

Designation	Clamping screw	Wrench	Coolant plug	Wrench	DirectJet plug	Wrench
JSXXR...	CSTC-4L100DL	T-1008/5	SR5/16UNFTL360	P-4	SSHM4-6-TB	P-2
JSXXL...	CSTC-4L100DR	T-1008/5	SR5/16UNFTL360	P-4	SSHM4-6-TB	P-2

Parting-off widths : 0.039" and 0.059" (for a max parting diameter of ø0.236")

: 0.059" and 0.079" (for max parting diameters of ø0.472", ø0.630" and ø0.787")

Threading pitch range : 0.008" - 0.059"

See page 42 for the proper tool overhang and plug settings.

JSXXR/L-CHP

Tube connection

Parting-off and threading toolholder. High pressure coolant capability.

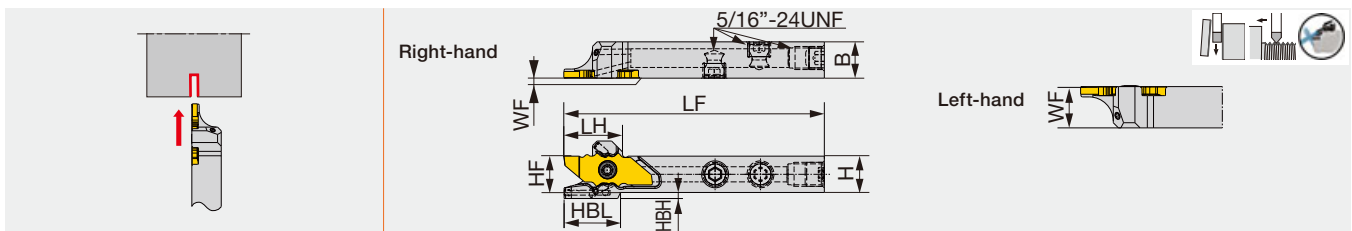

Inch	CW	H	B	LF**	LH**	HF	WF	HBL**	HBH	Insert	Torque*
JSXXR/L083F-CHP	0.039 - 0.079	0.500	0.500	3.344	0.764	0.5	0.008/0.492	0.736	0.051	JX*G06..., 12..., 16..., 20...	0.890

*Torque: Recommended torque (lbf-ft) for clamping

**LF (Functional Length) LH (Head Length), and HBL (Head-bottom Offset Length) values shown above are true with JXPG16... insert. LF, LH, and HBL will all be 0.079" shorter than the above values with JX*G12... and JXPG20... inserts, and 0.157" shorter for JXPG06... insert.

Note: Use the right-hand insert (JX*G**R...) for a right-hand holder (JSXXR...); the left-hand insert (JX*G**L...) for a left-hand holder (JSXXL...).

SPARE PARTS

Designation	Clamping screw	Wrench	Coolant plug	Wrench
JSXXR...	CSTC-4L100DL	T-1008/5	SR5/16UNFTL360	P-4
JSXXL...	CSTC-4L100DR	T-1008/5	SR5/16UNFTL360	P-4

Parting-off widths : 0.039" and 0.059" (for a max parting diameter of ø0.236")

: 0.059" and 0.079" (for max parting diameters of ø0.472", ø0.630" and ø0.787")

Threading pitch range : 0.008 - 0.059"

Hose connection to the tool holder refer to page 52

JSXXR/L-S-CHP

DIRECTJET Direct connection

Parting-off tool holder, capable with sub spindle, high-pressure coolant compatible

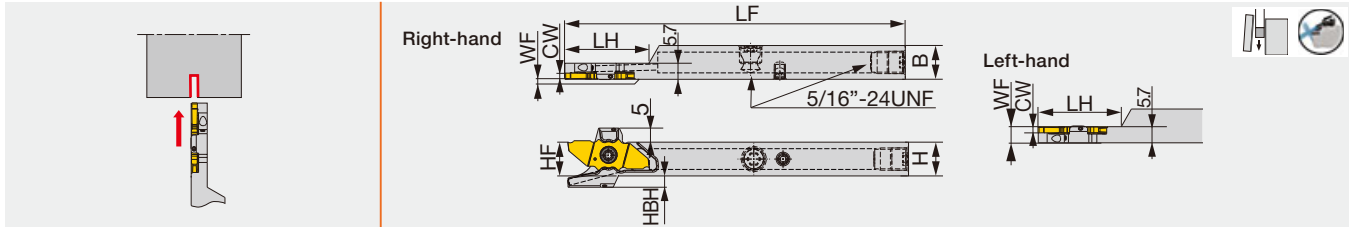

Inch	CW	H	B	LF**	LH**	HF	WF	HBH	Insert	Torque*
JSXXR/L083X-S-CHP	0.039 - 0.079	0.500	0.500	4.750	1.181	0.500	0.008/0.217	0.051	JX*G06...,12...,16...,20...	0.890
JSXXR/L103X-S-CHP	0.039 - 0.079	0.625	0.625	4.750	1.181	0.625	0.008/0.217	0	JX*G06...,12...,16...,20...	0.890

*Torque: Recommended torque (lbf-ft) for clamping

**LF (Overall Tool Length) and LH (Head Length) values shown above are true with JXPG16... insert. Both LF and LH will be 0.079" shorter than the above value with JX*G12... and JXPG20... inserts; 0.157" shorter with JXPG06... insert.

Note: Use the right-hand insert (JX*G**R...) for a right-hand holder (JSXXR...); the left-hand insert (JX*G**L...) for a left-hand holder (JSXXL...).

SPARE PARTS

Designation	Clamping screw	Wrench	Coolant plug	Wrench	DirectJet plug	Wrench
JSXXR***-S-CHP	CSTC-4L055DL	T-1008/5	SR5/16UNFTL360	P-4	SSHM4-6-TB	P-2
JSXXL***-S-CHP	CSTC-4L055DR	T-1008/5	SR5/16UNFTL360	P-4	SSHM4-6-TB	P-2

Parting-off widths : 0.039" and 0.059" (for a max parting diameter of $\phi 0.236$ ")

: 0.059" and 0.079" (for max parting diameters of $\phi 0.472$ ", $\phi 0.630$ " and $\phi 0.787$ ")

See page 42 for the proper tool overhang and plug settings.

JSXXR/L-F-S-CHP

Tube connection

Parting-off toolholder for sub-spindle, with high pressure coolant capability.

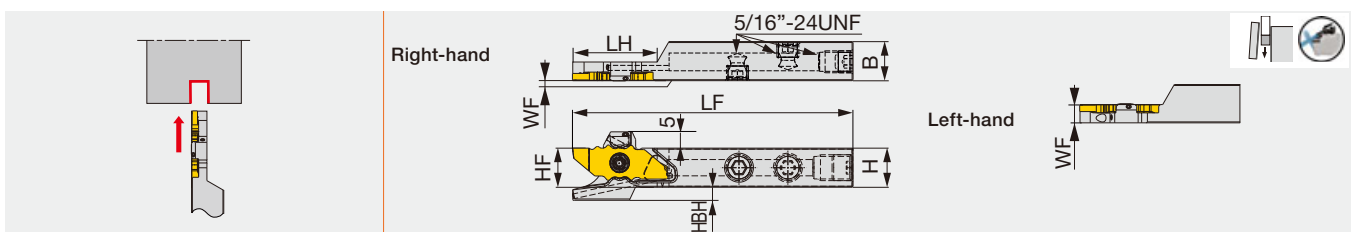

Inch	CW	H	B	LF**	LH**	HF	WF	HBH	Insert	Torque*
JSXXR/L083F-S-CHP	0.039 - 0.079	0.500	0.500	3.344	1.024	0.500	0.008/0.217	0.051	JX*G06...,12...,16...,20...	0.890

*Torque: Recommended torque (lbf-ft) for clamping

**LF (Overall Tool Length) and LH (Head Length) values shown above are true with JXPG16... insert. Both LF and LH will be 0.079" shorter than the above value with JX*G12... and JXPG20... inserts; 0.157" shorter with JXPG06... insert.

Note: Use the right-hand insert (JX*G**R...) for a right-hand holder (JSXXR...); the left-hand insert (JX*G**L...) for a left-hand holder (JSXXL...).

SPARE PARTS

Designation	Clamping screw	Wrench	Coolant plug	Wrench
JSXXR...	CSTC-4L100DL	T-1008/5	SR5/16UNFTL360	P-4
JSXXL...	CSTC-4L100DR	T-1008/5	SR5/16UNFTL360	P-4

Parting-off widths : 0.039" and 0.059" (for a max parting diameter of $\phi 0.236$ ")

: 0.059" and 0.079" (for max parting diameters of $\phi 0.472$ ", $\phi 0.630$ " and $\phi 0.787$ ")

Threading pitch range : 0.008" - 0.059" (17 - 127 TPI)

Hose connection to the tool holder refer to page 52

When using with the DirectTungJet system for small lathes

- Adjust the tool overhang length as insert space in Table1 below.
- Remove the plug as specified in Table 1 below when using with the direct coolant system.

Table 1

Machine model	Tool settings for a 20 x 20 mm square shank ⁽¹⁾		Tool settings for a 16 x 16 mm square shank ⁽¹⁾		Tool settings for a 12 x 12 mm square shank	
	Overhang L1 (mm)	Coolant plug to remove	Overhang L1 (mm)	Coolant plug to remove	Overhang L1 (mm)	Coolant plug to remove
CINCOM L20	-	-	30	B1	20 ⁽²⁾	B1
CINCOM D25	25	B1	25	B1	-	-

(1): 20 x 20 mm and 16 x 16 mm square shanks of DuoJustCut and TungCut have both Plug B1 and Plug B2 on the shank body. Others have only Plug B1.

(2): The overhang length for the 12 x 12 mm TungCut shank should be 30 mm. (used in Tool Post #1 only)

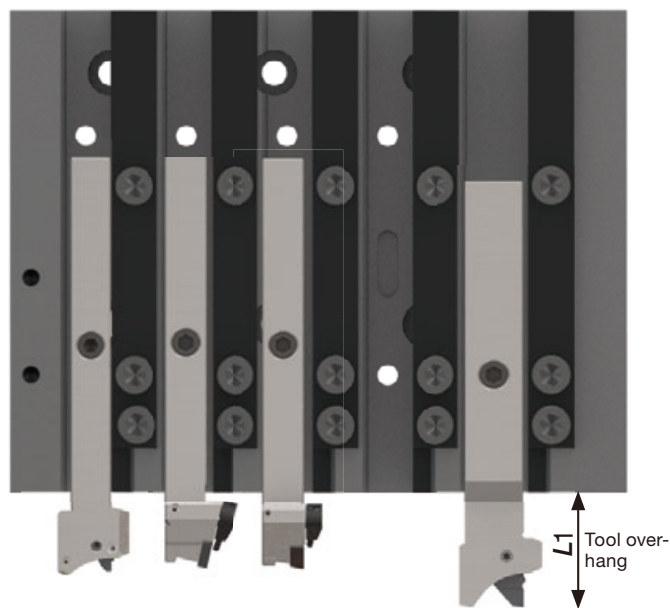
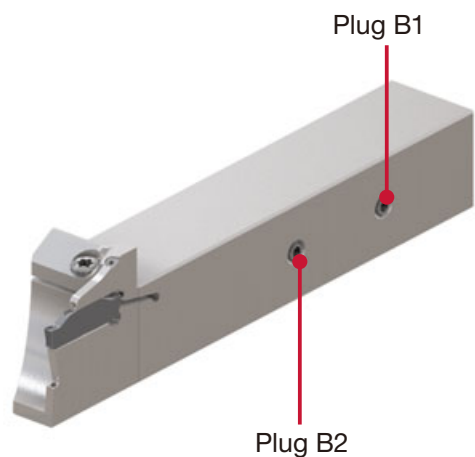

ETFR-CHP

Tube connection

Toolholders for face grooving & turning with channels for high-pressure coolant

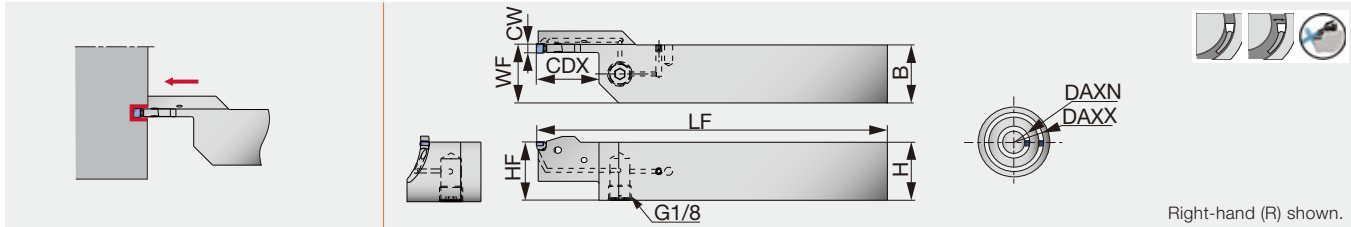

Inch	CW	DAXN	DAXX	CDX	H	B	LF	HF	WF	Insert
ETFR16-4T15-030035-CHP	0.157	1.181	1.378	0.591	1.000	1.000	6.000	1.000	1.020	E**4...
ETFR16-4T22-035045-CHP	0.157	1.378	1.772	0.866	1.000	1.000	6.000	1.000	1.020	E**4...
ETFR16-4T25-045055-CHP	0.157	1.772	2.165	0.984	1.000	1.000	6.000	1.000	1.020	E**4...
ETFR16-4T25-055075-CHP	0.157	2.165	2.953	0.984	1.000	1.000	6.000	1.000	1.020	E**4...
ETFR16-4T25-075120-CHP	0.157	2.953	4.724	0.984	1.000	1.000	6.000	1.000	1.020	E**4...
ETFR16-4T25-120200-CHP	0.157	4.724	7.874	0.984	1.000	1.000	6.000	1.000	1.020	E**4...
ETFR16-4T25-200500-CHP	0.157	7.874	19.685	0.984	1.000	1.000	6.000	1.000	1.020	E**4...

SPARE PARTS



Designation	Wrench*
ETFR...-CHP	ECW-456EF

*Optional parts

Hose connection to the tool holder refer to page 52

EFPR/L

Adjustable blade for face grooving

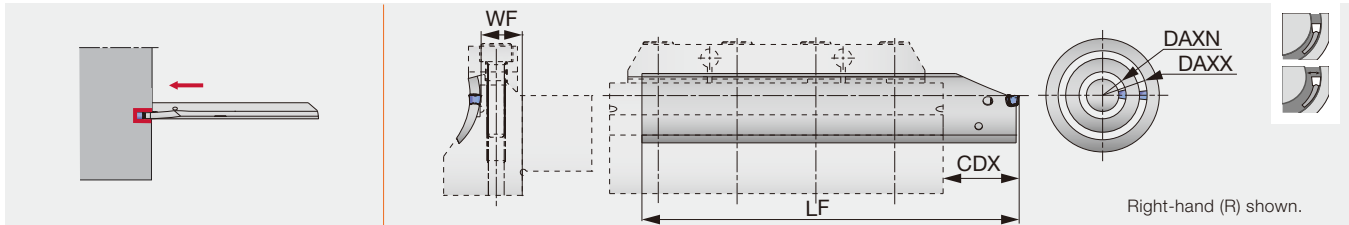

Inch	CW	DAXN	DAXX	WF	LF	Min.CDX	Max.CDX	Insert
EFPR/L-4-030035	0.157	1.181	1.378	0.535	4.921	0.709	1.968	E**4...
EFPR-4-035045	0.157	1.378	1.772	0.535	4.921	0.709	1.968	E**4...
EFPR-4-045055	0.157	1.772	2.165	0.535	4.921	0.709	1.968	E**4...
EFPR-4-055075	0.157	2.165	2.953	0.535	4.921	0.709	1.968	E**4...
EFPR-4-075120	0.157	2.953	4.724	0.535	5.512	0.709	2.559	E**4...
EFPR-4-120200	0.157	4.724	7.874	0.535	5.512	0.709	2.559	E**4...
EFPR-4-200500	0.157	7.874	19.685	0.535	5.512	0.709	2.559	E**4...
EFPR-5-035045	0.197	1.378	1.772	0.535	4.921	0.748	1.968	ETX5...
EFPR-5-045055	0.197	1.772	2.165	0.535	4.921	0.748	1.968	ETX5...
EFPR-5-055075	0.197	2.165	2.953	0.535	4.921	0.748	1.968	ETX5...
EFPR-5-075120	0.197	2.953	4.724	0.535	5.512	0.748	2.559	ETX5...
EFPR-5-120200	0.197	4.724	7.874	0.535	5.512	0.748	2.559	ETX5...
EFPR-5-200500	0.197	7.874	19.685	0.535	5.512	0.748	2.559	ETX5...
EFPR-6-045055	0.236	1.772	2.165	0.535	4.921	0.787	1.968	ETX6...
EFPR-6-055075	0.236	2.165	2.953	0.535	4.921	0.787	1.968	ETX6...
EFPR-6-075120	0.236	2.953	4.724	0.535	5.512	0.787	2.559	ETX6...
EFPR-6-120200	0.236	4.724	7.874	0.535	5.512	0.787	2.559	ETX6...
EFPR/L-6-200500	0.236	7.874	19.685	0.535	5.512	0.787	2.559	ETX6...

SPARE PARTS



Designation	Wrench*
EFPR/L...	ECW-456I

*Optional parts

CTBU-CHP for EFPR/L

Tool block for EasyMulti-Cut face blade series with channels for high-pressure coolant

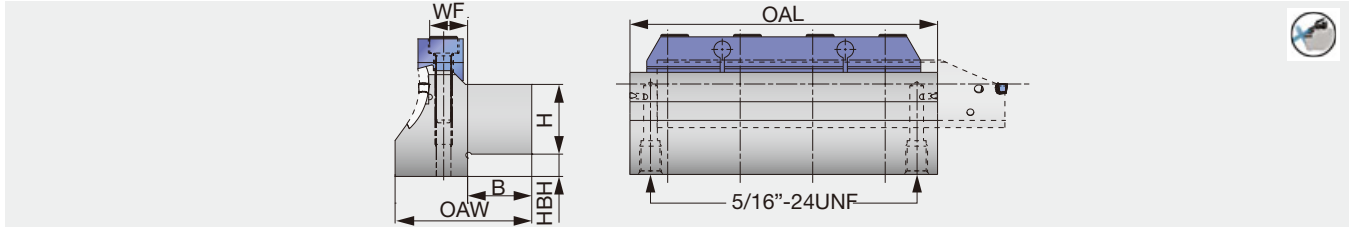

Inch	CW	DAXN	H	B	HBH	OAW	OAL	Blade
CTBU16-030-4U-CHP	0.157	1.181	1.000	0.905	0.299	1.929	4.331	EFPR/L-4-030035
CTBU16-035-4/5U-CHP	0.157, 0.197	1.378	1.000	0.905	0.299	1.929	4.331	EFPR/L-4/5-035045
CTBU16-045-4/5U-CHP	0.157, 0.197	1.772	1.000	0.905	0.299	1.929	4.331	EFPR/L-4/5-045055
CTBU16-055-4/5U-CHP	0.157, 0.197	2.165	1.000	0.905	0.299	1.85	4.331	EFPR/L-4/5-055075
CTBU16-075-4/5U-CHP	0.157, 0.197	2.953	1.000	0.905	0.299	1.771	4.331	EFPR/L-4/5-075120
CTBU16-120-4/5U-CHP	0.157, 0.197	4.724	1.000	0.905	0.299	1.732	4.331	EFPR/L-4/5-120200
CTBU16-200-4/5U-CHP	0.157, 0.197	7.874	1.000	0.905	0.299	1.633	4.331	EFPR/L-4/5-200500
CTBU16-045-6U-CHP	0.236	1.772	1.000	0.905	0.299	2.007	4.331	EFPR/L-6-045055
CTBU16-055-6U-CHP	0.236	2.165	1.000	0.905	0.299	1.929	4.331	EFPR/L-6-055075
CTBU16-075-6U-CHP	0.236	2.953	1.000	0.905	0.299	1.85	4.331	EFPR/L-6-075120
CTBU16-120-6U-CHP	0.236	4.724	1.000	0.905	0.299	1.811	4.331	EFPR/L-6-120200
CTBU16-200-6U-CHP	0.236	7.874	1.000	0.905	0.299	1.712	4.331	EFPR/L-6-200500

SPARE PARTS



Designation	Clamping screw	Clamp	Wrench
CTBU...-CHP	CM6X30-S	CT-110	P-5

New

SER-X-CHP-MC

Direct connection

Tube connection

Screw-on external threading toolholders, High-pressure coolant capability with tube and direct connection

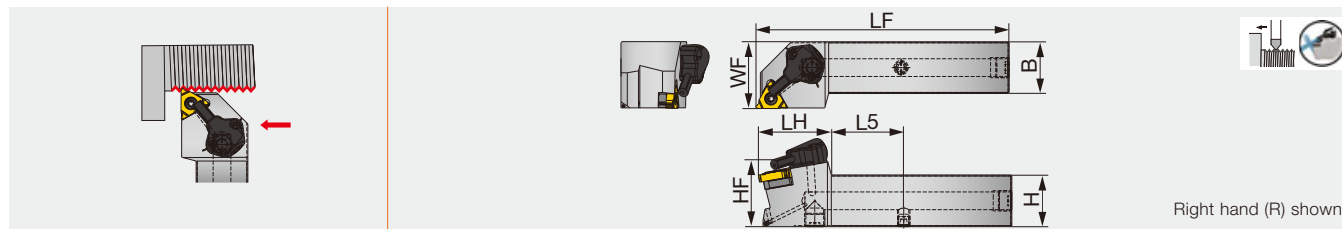

Metric	H	B	LF	LH	HF	WF	L5	Insert
SER2020X16-CHP-MC	20	20	107	36	20	32	27.9	16ER...
SER2525X16-CHP-MC	25	25	122	36	25	32	33.75	16ER...
SER2525X22-CHP-MC	25	25	122	36	25	32	33.75	16ER...

SPARE PARTS

Designation	Clamping screw	Wrench	Shim screw	Shim	Coolant unit	Coolant plug	Wrench
SER**X16-CHP-MC	CSTB-3.5ST	T-15F	DTS5-3.5	A16-1DT	CU-V-CHP	PLUGG1/8-6.5TL360	P-3.5
SER**X22-CHP-MC	CSTB-4ST	T-15F	DTS6-4	GX22-1DT	CU-CW-CHP	PLUGG1/8-6.5TL360	P-4

JSE2R16-CHP

Screw-on external threading toolholders, High-pressure capability with tube and direct connection

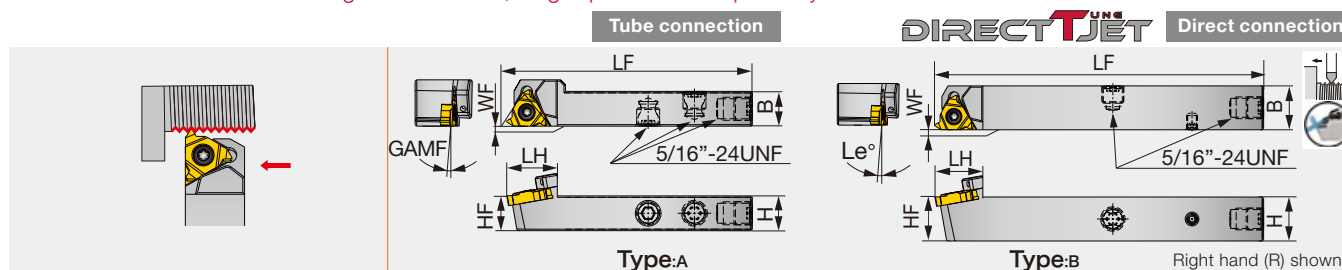

Inch	H	B	LF	LH	HF	WF	GAMF	Type	Insert
JSE2R08F16-CHP	0.500	0.500	3.344	0.748	0.500	0	1°	A	16ER...
JSE2R08X16-CHP	0.500	0.500	4.750	0.748	0.500	0	1°	B	16ER...
JSE2R10X16-CHP	0.625	0.625	4.750	0.748	0.625	0	1°	B	16ER...

Metric	H	B	LF	LH	HF	WF	GAMF	Type	Insert
JSE2R1212F16-CHP *	12	12	85	19	12	0	1°	A	16ER...
JSE2R1212X16-CHP	12	12	120	19	12	0	1°	B	16ER...
JSE2R1616X16-CHP	16	16	120	19	16	0	1°	B	16ER...





* External coolant tube connection type

SPARE PARTS

Designation	Clamping screw	Wrench	Coolant plug	Wrench
JSE2R**16-CHP	CSTB-3.5	T-15F	SR5/16UNFTL360	P-4

VDI adapters

VDI30 B1B4 A - 302040-JHPMC

1	2	3							
<table border="1"> <tr><td>1</td></tr> <tr><td>20</td></tr> <tr><td>25</td></tr> <tr><td>30</td></tr> <tr><td>40</td></tr> </table>	1	20	25	30	40	<p>2 B1B4 : Radial toolholder : for Left hand tool holder</p> 	<p>3 C1C4 : Axial toolholder : for Right hand tool holder</p> 	<p>3 A type Clamping screw on top, parallel clamping</p> 	<p>3 AK type Clamping screw on side, Wedge clamping</p> 
1									
20									
25									
30									
40									
	<p>B2B3 : Radial toolholder : for Right hand tool holder</p>	<p>C2C3 : Axial toolholder : for Left hand tool holder</p>							

VDI & PSC Adapter

VDI**B1B4A-JHPMC

VDI adapter for square shank tool holder, with hose-free direct coolant supply

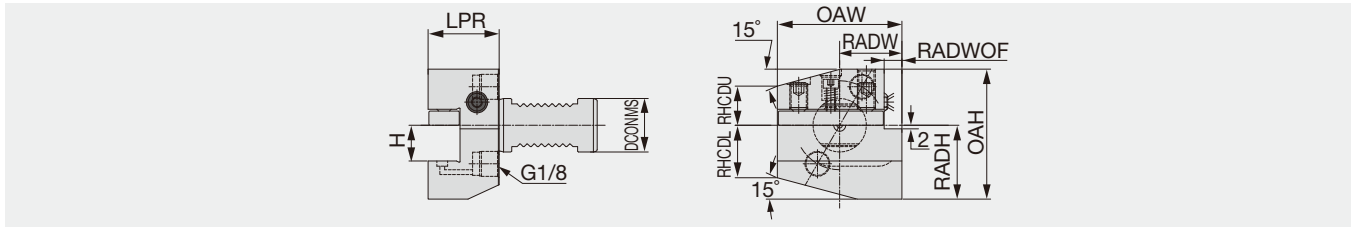

Metric	DCONMS	H	LPR	OAW	RADW	RADWOF	RHCDL	RHCDU	RADH	OAH
VDI20B1A-201640-JHPMC	20	16	40	55	30	7	19	19	30	55
VDI20B4A-201640-JHPMC	20	16	40	55	30	7	19	19	30	55
VDI25B1A-252040-JHPMC	25	20	40	70	35	10	29.5	22	38.5	70
VDI30B1B4A-302040-JHPMC	30	20	40	70	35	10	29.5	22	41.5	73
VDI40B1B4A-402544-JHPMC	40	25	44	85	42.5	12.5	35	30	48	86

Applicable for 8 MPa pressure coolant

VDI**B1B4AK-JHPMC

VDI adapter for square shank tool holder, with hose-free direct coolant supply

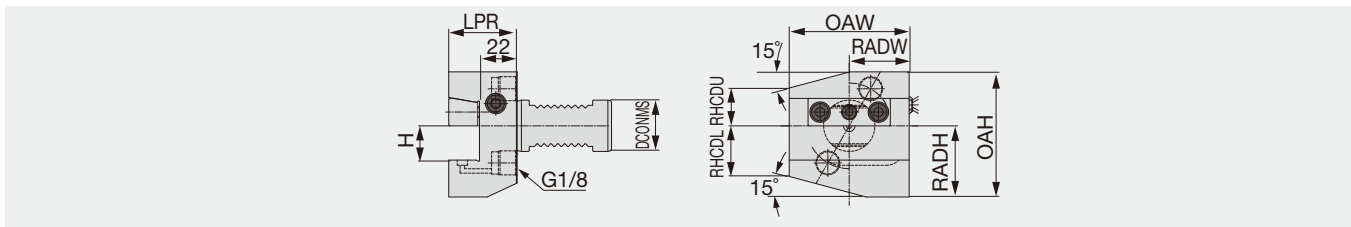

Metric	DCONMS	H	LPR	OAW	RADW	RHCDL	RHCDU	RADH	OAH
VDI30B1B4AK-302040-JHPMC	30	20	40	70	35	29.5	22	41.5	73
VDI40B1B4AK-402544-JHPMC	40	25	44	85	42.5	35	30	48	86

Applicable for 8 MPa pressure coolant

VDI**B2B3A-JHPMC

VDI adapter for square shank tool holder, with hose-free direct coolant supply

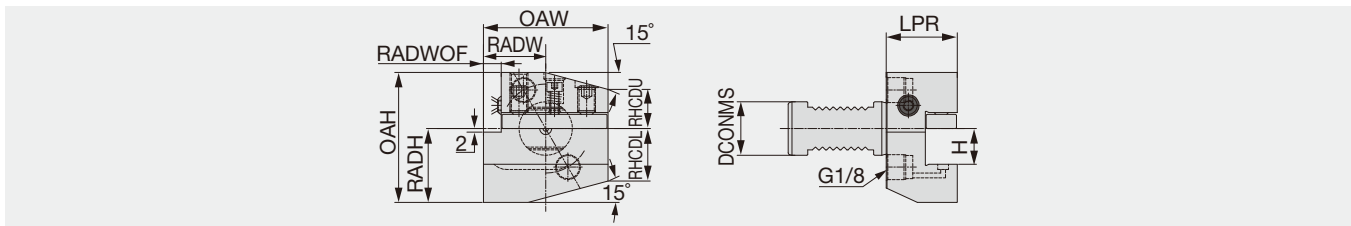

Metric	DCONMS	H	LPR	OAW	RADW	RADWOF	RHCDL	RHCDU	RADH	OAH
VDI20B2A-201640-JHPMC	20	16	40	55	30	7	19	19	30	55
VDI20B3A-201640-JHPMC	20	16	40	55	30	7	19	19	30	55
VDI25B2A-252040-JHPMC	25	20	40	70	35	10	29.5	22	38.5	70
VDI30B2B3A-302040-JHPMC	30	20	40	70	35	10	29.5	27	41.5	73
VDI40B2B3A-402544-JHPMC	40	25	44	85	42.5	12.5	35	30	48	86

Applicable for 8 MPa pressure coolant

VDI**C1C4A-JHPMC

VDI adapter for square shank tool holder, with hose-free direct coolant supply

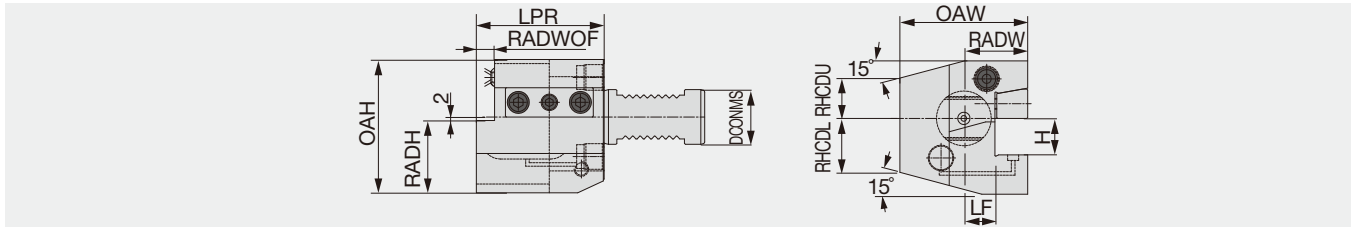

Metric	DCONMS	H	LPR	OAW	RADW	LF	RADWOF	RHCDL	RHCDU	RADH	OAH
VDI25C1C4A-252055-JHPMC	25	20	55	58	33	13	7	26	28	36	66
VDI30C1C4A-302070-JHPMC	30	20	70	70	35	17	10	26	22	38	70
VDI40C1C4A-402585-JHPMC	40	25	85	85	42.5	21	12.5	35	30	48	86

Applicable for 8 MPa pressure coolant

VDI**C1C4AK-JHPMC

VDI adapter for square shank tool holder, with hose-free direct coolant supply

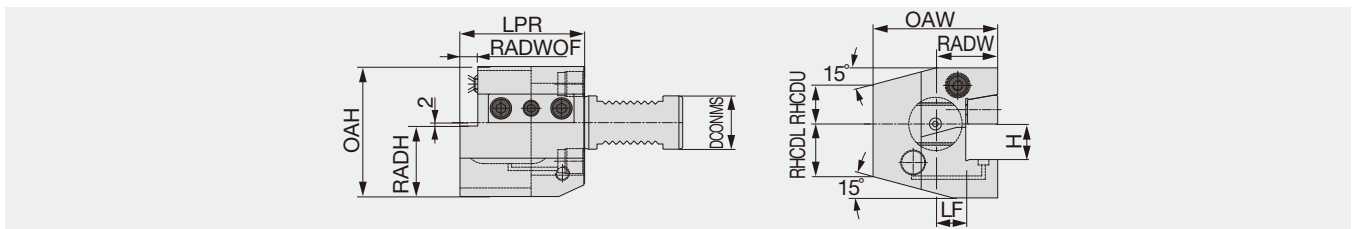

Metric	DCONMS	H	LPR	OAW	RADW	LF	RADWOF	RHCDL	RHCDU	RADH	OAH
VDI30C1C4AK-302070-JHPMC	30	20	70	70	35	17	10	26	22	38	70
VDI40C1C4AK-402585-JHPMC	40	25	85	85	42.5	21	12.5	35	30	48	86

Applicable for 8 MPa pressure coolant

VDI & PSC Adapter

VDI**C2C3A-JHPMC

VDI adapter for square shank tool holder, with hose-free direct coolant supply

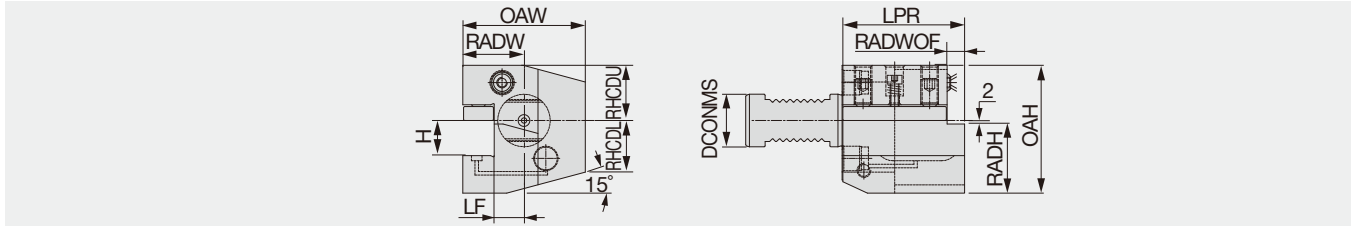

Metric	DCONMS	H	LPR	OAW	RADW	LF	RADWOF	RHCDL	RHCDU	RADH	OAH
VDI25C2C3A-252055-JHPMC	25	20	55	52	37	15	7	38	38	36	66
VDI30C2C3A-302070-JHPMC	30	20	70	76	41	17	10	26	26	38	70
VDI40C2C3A-402585-JHPMC	40	25	85	90	47.5	21	12.5	35	30	48	86

Applicable for 8 MPa pressure coolant

VDI**C2C3AK-JHPMC

VDI adapter for square shank tool holder, with hose-free direct coolant supply

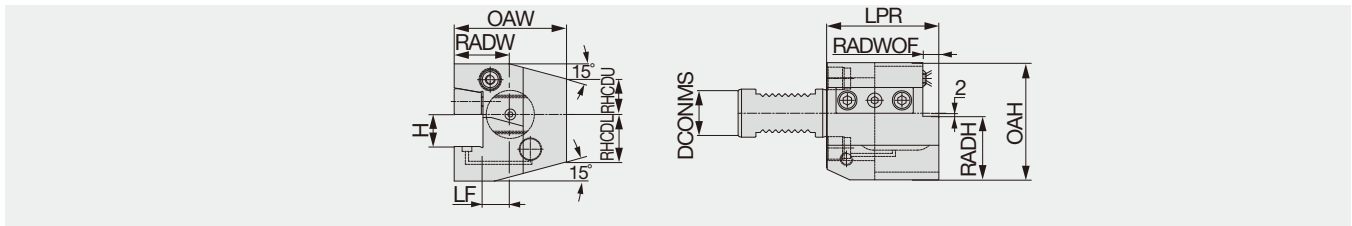

Metric	DCONMS	H	LPR	OAW	RADW	LF	RADWOF	RHCDL	RHCDU	RADH	OAH
VDI30C2C3AK-302070-JHPMC	30	20	70	76	41	17	10	26	22	38	70
VDI40C2C3AK-402585-JHPMC	40	25	85	90	47.5	21	12.5	35	30	48	86

Applicable for 8 MPa pressure coolant

C*ASHA-HPMC



PSC adapter for square shank tool holder, with hose-free direct coolant supply

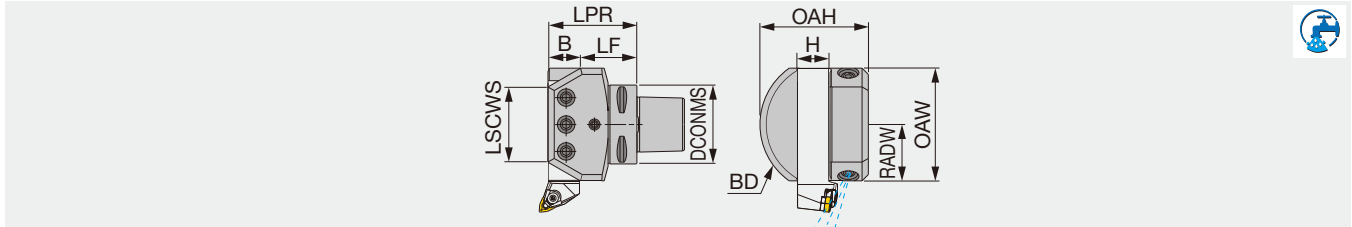

Metric	DCONMS	H	B	LPR	LSCWS	LF	RADW	OAW	OAH	BD
C6ASHA25-HPMC	63	25	25	71	61	46	45	90	86.6	110

C*ASHR/L-HPMC



PSC adapter for square shank tool holder, with hose-free direct coolant supply

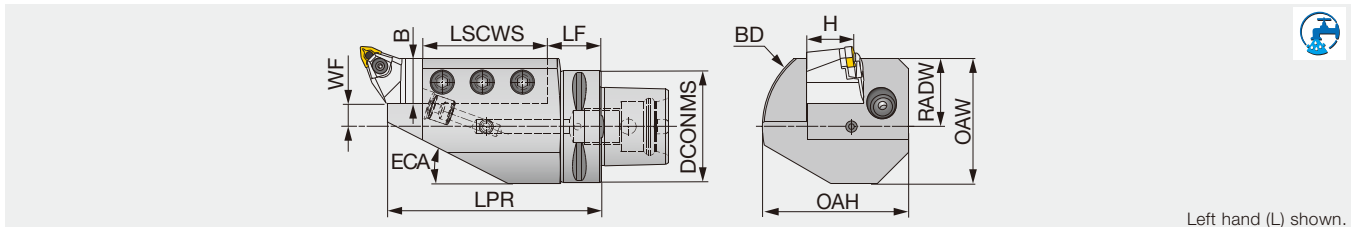

Metric	DCONMS	LPR	LSCWS	LF	WF	H	B	OAH	RADW	OAW	BD	ECA
C6ASHR251-J-HPMC	63	120	82	38	4.5	25	25	76.5	29.5	61	90	27
C6ASHL251-HPMC	63	120	70	30	13	25	25	82	38	70	100	27

C*ASHR/L-45-HPMC



PSC adapter for square shank tool holder, with hose-free direct coolant supply

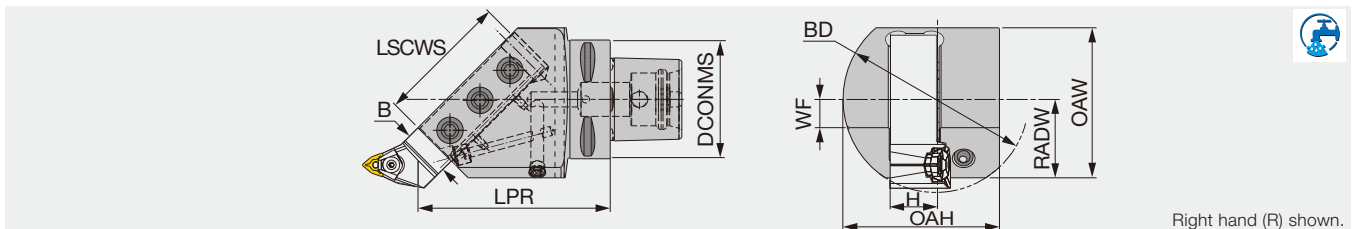

Metric	DCONMS	H	B	LSCWS	LPR	OAH	RADW	OAW	WF	BD
C6ASHR/L25-45-HPMC	63	25	25	70	102	83	41.6	79.6	15	100

CONNECTION OF TOOLHOLDER AND COOLANT HOSE

- Toolholder sizes of over 0.787": Hose on the bottom of the head
- Toolholder sizes of less than 0.630": Hose on the back, front, or back end side

For general lathes (P-type)

Designation	PCLN... / PDJN... / PTGN... / PV*N... / PWLN...	ACLN... / AWLN... / ADJLN...
Shank size	Over 0.787"	Over 0.787"
Example of connection		
Washer	CHP-COPPER-SEAL1/8	CHP-COPPER-SEAL1/8
Connector	CHP-NIPPLE-G1/8-7/16UNF	CHP-NIPPLE-G1/8-7/16UNF
Hose	CHP-HOSE-G1/8-7/16-200BS ⁽¹⁾	CHP-HOSE-G1/8-7/16-200BS ⁽¹⁾
	CHP-HOSE-G1/8-7/16-250BS ⁽¹⁾	CHP-HOSE-G1/8-7/16-250BS ⁽¹⁾
	CHP-HOSE-5/16-7/16-200BS ⁽²⁾	CHP-HOSE-5/16-7/16-200BS ⁽²⁾

Thread size of hose for machine: ⁽¹⁾G1/8"-28 BSPP, ⁽²⁾5/16"-24UNF

For small lathes (J-type)

Designation	JSDJ2X... / JSWL2X... / JSVJ2X... / JSDJ2C... / JSVJ2B...		
Shank size	≤ 0.630"		
Connection	Back	Front	Back end
Example of connection			
Connector for toolholder	CHP-CONNECTOR5/16-G1/8	-	-
Hose	CHP-HOSE-G1/8-7/16-200BS ⁽³⁾	CHP-HOSE-5/16-7/16-200BS ⁽³⁾	CHP-HOSE-5/16-7/16-200BS ⁽³⁾
	CHP-HOSE-G1/8-7/16-250BS ⁽³⁾	-	-
	CHP-HOSE-G1/8-G1/8-200BB ⁽⁴⁾	-	-
	CHP-HOSE-G1/8-G1/8-250BB ⁽⁴⁾	-	-
Connector for machine ⁽⁵⁾	CHP-NIPPLE-G1/8-7/16UNF	CHP-NIPPLE-G1/8-7/16UNF	CHP-NIPPLE-G1/8-7/16UNF
Washer for machine ⁽⁵⁾	CHP-COPPER-SEAL1/8	CHP-COPPER-SEAL1/8	CHP-COPPER-SEAL1/8

(3): The tube thread type on the machine side is 7/16" -20UNF, female thread. Therefore, use both Nipple (5) and Washer (5) to connect to the machine G1/8 female thread.

(4): The thread type on the machine side is G1/8" -28 BSPP, male thread.

PARTS FOR COOLANT HOSE

Connecting hose

Fig. 1

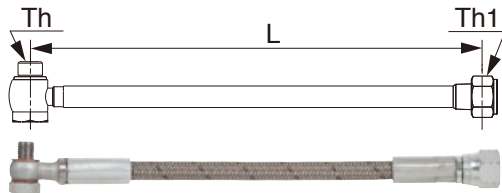
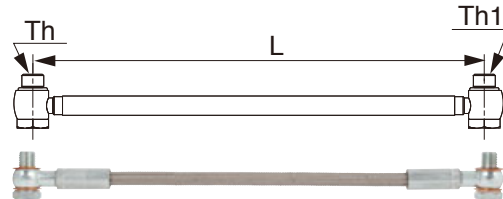
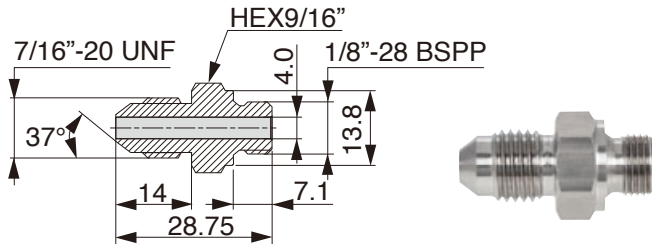

Fig. 2



Inch	Length L	Threading size		Max. pressure (Mpa)	Fig.
		Th	Th1		
CHP-HOSE-G1/8-7/16-200BS	7.874	G1/8"-28 BSPP	7/16"-20 UNF	3770	1
CHP-HOSE-G1/8-7/16-250BS	9.843	G1/8"-28 BSPP	7/16"-20 UNF	3770	1
CHP-HOSE-5/16-7/16-200BS	7.874	5/16"-24UNF	7/16"-20 UNF	2900	1
CHP-HOSE-5/16-G1/8-200BS	7.874	5/16"-24UNF	G1/8"-28 BSPP	2900	1
CHP-HOSE-G1/8-G1/8-200BB	7.874	G1/8"-28 BSPP	G1/8"-28 BSPP	3770	2
CHP-HOSE-G1/8-G1/8-250BB	9.843	G1/8"-28 BSPP	G1/8"-28 BSPP	3770	2

Connector



Inch
CHP-NIPPLE-G1/8-7/16UNF

Seal washer

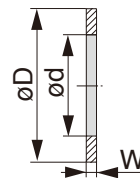

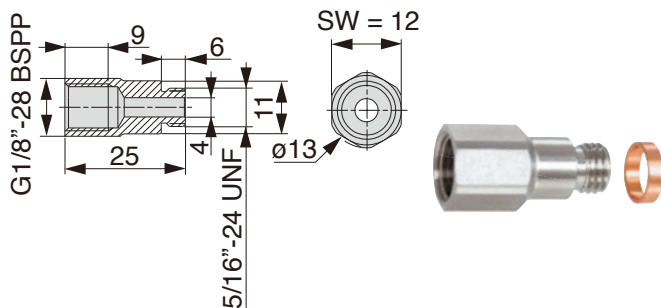

Inch	øD	ød	W
CHP-COPPER-SEAL1/8	0.590	0.315	0.039
CHP-COPPER-SEAL5/16	0.430	0.315	0.039
CHP-COPPER-SEAL5/16-2.5	0.430	0.315	0.098

Connector for small lathe with seal washer

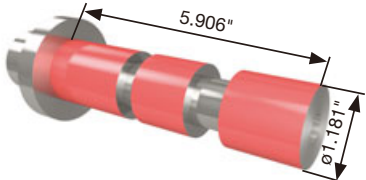
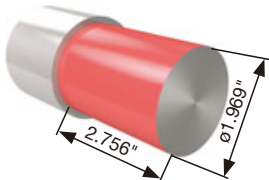
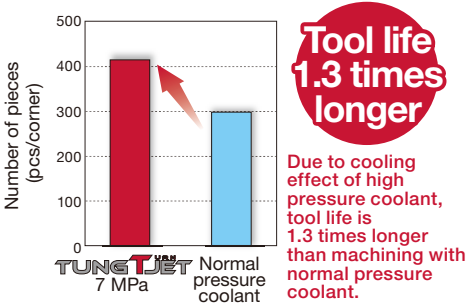
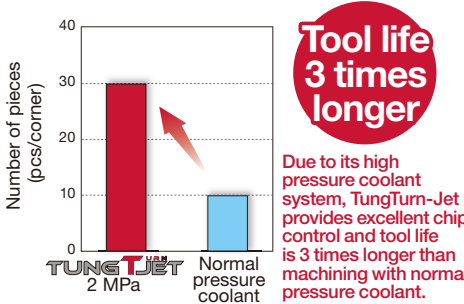

Inch
CHP-CONECTOR/5/16-G1/8

PRACTICAL EXAMPLES

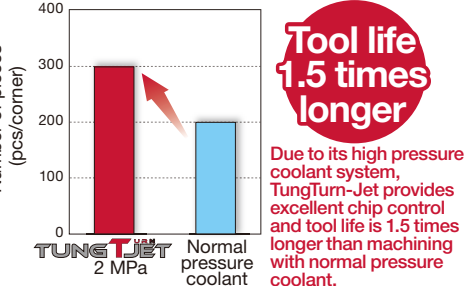
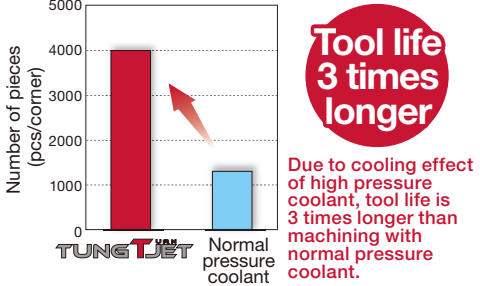
	Valve parts	Tube parts	
Workpiece type	Valve parts	Tube parts	
Toolholder	PDJNR2525M15-CHP	PCLNR2525M12-CHP	
Insert	DNMG 432 HRM	CNMG 432 HRM	
Grade	AH8015	AH8015	
Workpiece material	INCONEL 718	Ti-6AL-4V	
			
Cutting conditions	Cutting speed : Vc(sfm)	262	197
	Feed : f (ipr)	0.012	0.008
	Depth of cut : ap (in)	0.079	0.079
	Machining	External turning	External turning
	Coolant	Wet	Wet
Results			
Workpiece type	Shaft	Shaft stator	
Toolholder	JSDJ2CR1616X11-CHP	STCR2525-27-CHP	
Insert	DCGT 32.50.5 FN-JS	TCS27-200-020	
Grade	SH725	AH725	
Workpiece material	S30400	4140	
			
Cutting conditions	Cutting speed : Vc(sfm)	302	591
	Feed : f (ipr)	0.059	0.005
	Depth of cut : ap (in)	11.811	0.079
	Machining	External turning	External grooving
	Coolant	Wet	Wet
Results			

Check our site and our App to get more info!



Turning Solutions Grinding Solutions Milling Solutions Drilling Solutions



Available on the App Store GET IT ON Google play

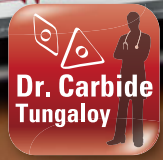

Available on the App Store GET IT ON Google play

Tungaloy America, Inc.

3726 N Ventura Drive, Arlington Heights, IL 60004, U.S.A.

Inside Sales: +1-888-554-8394

Technical Support: +1-888-554-8391

Fax: +1-888-554-8392

www.tungaloy.com/us

Tungaloy Canada

432 Elgin St. Unit 3, Brantford, Ontario N3S 7P7, Canada

Phone: +1-519-758-5779 Fax: +1-519-758-5791

www.tungaloy.com/ca

Tungaloy de Mexico S.A.

C Los Arellano 113, Parque Industrial Siglo XXI

Aguascalientes, AGS, Mexico 20290

Phone: +52-449-929-5410 Fax: +52-449-929-5411

www.tungaloy.com/mx



Scan for instant
web access



www.tungaloy.com/us

follow us at:

facebook.com/tungaloyamerica

twitter.com/tungaloy

instagram.com/tungaloyamerica

linkedin.com/company/tungaloy-america

To see this product in action visit:

Tung-TV

www.youtube.com/tungaloycorporation

Distributed by:



FIND US ON THE CLOUD!
machingcloud.com

