

Vargus Ltd. is pleased to introduce

EXPANSION

MACH TT Toolholders Round Shanks for External Applications in Swiss-Type Machines

Features and Benefits:

- Increase toolholder position - when there isn't space for clamping on the square shank magazine, the new round shank toolholder design enables clamping the tool in the drill sleeve position
- Left Hand toolholder with round shank - for use with external Right Hand inserts
- Available for MACH TT IC3/8" external inserts
- Front relief toolholder for extra-close clamping and support

Refer to the VARGUS GENius™ for tool selection and cutting conditions.

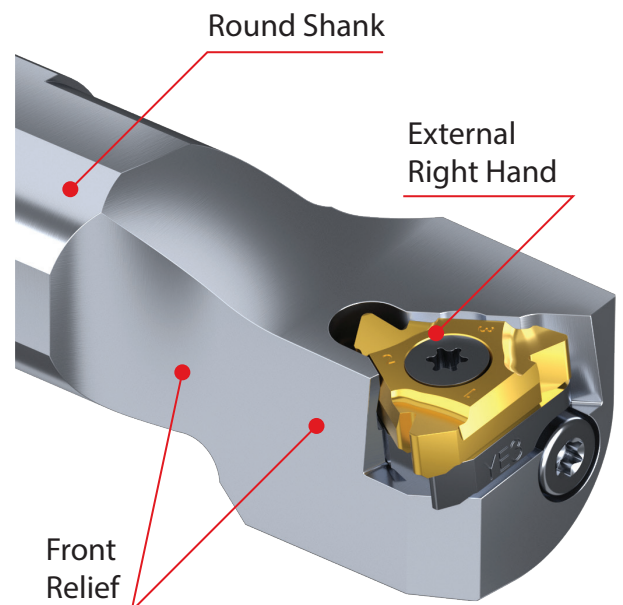

Please contact me directly with specific questions and requests.
For additional updates and news visit the VARGUS website: www.vargus.com

Ami Yacar
Vardex Product Manager

Scroll down for complete details 

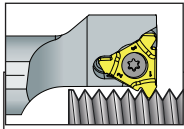

External Toolholders with Round Shanks

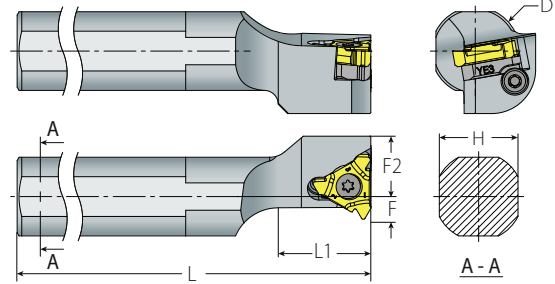
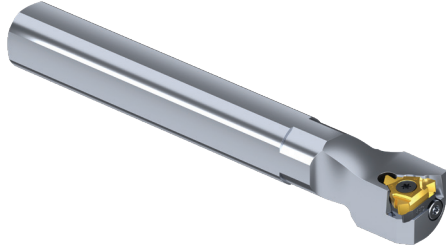

MACH TT Toolholders for Swiss Type Machines

Insert Size	Ordering Code	Market Description	Dimensions mm						Spare Parts			
			H	L	L1	D	F	F2	Insert Screw	Anvil Screw	Torx Key	Anvil RH
3/8"	ALVR075-3DT-LH	ALVR075-16DT-LH	17	140	20	.75 (inch)	6	13.5	SA3T	SY3T	K3T	YE3
	ALVR100-3DT-LH	ALVR100-16DT-LH	23			1.0 (inch)	10	16.0				
	ALVR20-3DT-LH	ALVR20-16DT-LH	18			20 (mm)	6	13.5				
	ALVR22-3DT-LH	ALVR22-16DT-LH	20			22 (mm)	6	13.5				
	ALVR25-3DT-LH	ALVR25-16DT-LH	23			25 (mm)	10	16.0				

MACH TT Toolholders for Swiss Type Machines (Inch)

Insert Size	Ordering Code	Market Description	EDP No.	Dimensions inch						Spare Parts			
				H	L	L1	D	F	F2	Insert Screw	Anvil Screw	Torx Key	Anvil RH
3/8"	ALVR075-3DT-LH	ALVR075-16DT-LH	67837	.67	5.51	.79	.75 (inch)	.24	.53	SA3T	SY3T	K3T	YE3
	ALVR100-3DT-LH	ALVR100-16DT-LH	67838	.91			1.0 (inch)	.39	.63				
	ALVR20-3DT-LH	ALVR20-16DT-LH	67839	.71			20 (mm)	.24	.53				
	ALVR22-3DT-LH	ALVR22-16DT-LH	67844	.79			22 (mm)	.24	.53				
	ALVR25-3DT-LH	ALVR25-16DT-LH	67863	.91			25 (mm)	.39	.63				



**COMPLETE
METALWORKING
SOLUTIONS**

(800) 991-4225

www.ahbinc.com

ISO Certified

customerservice@ahbinc.com