

SUPPLYPRO

INVENTORY MANAGEMENT SOLUTIONS



- Bring control and accountability to distributed inventory
- Provide information to better manage the supply chain
 - On Demand
 - On Schedule
- Blended Solutions: Consumables & Assets
 - Applications
 - Tailored
 - Scalable





Brains + brawn

- Ensure 24/7 availability of critical items
- Monitor usage, waste and theft
- Automated replenishment and procurement
- Ease of admin tasks
- Boost worker productivity
- Provide actionable metrics
- Enhance compliance



- Enterprise-Class Data Center
- No Servers to Manage
- Unrestricted Access & Licenses
- 20 years of experience



AT&T IDC Locations:

Annapolis Area, US
Atlanta Area, US (2)
Bangalore, IN
Boston Area, US
Chicago Area, US (2)
Dallas Area, US (2)
Los Angeles Area, US (2)
Miami Area, US
Nashville Area, US
New York Area, US
New York Metro Area, US (2)

Orlando Area, US
Phoenix Area, US
San Diego, US
San Francisco Area, US
San Jose Area, US
Seattle Area, US
Washington DC Area, US
Amsterdam, NE
Birmingham, UK

Frankfurt, DEU
London, UK
Nice, FR
Paris, FR
Hong Kong, CH
Osaka, Japan
Shanghai, CH (3)
Singapore, SG
Sydney, AU
Tokyo, JP (3)
Toronto, Canada

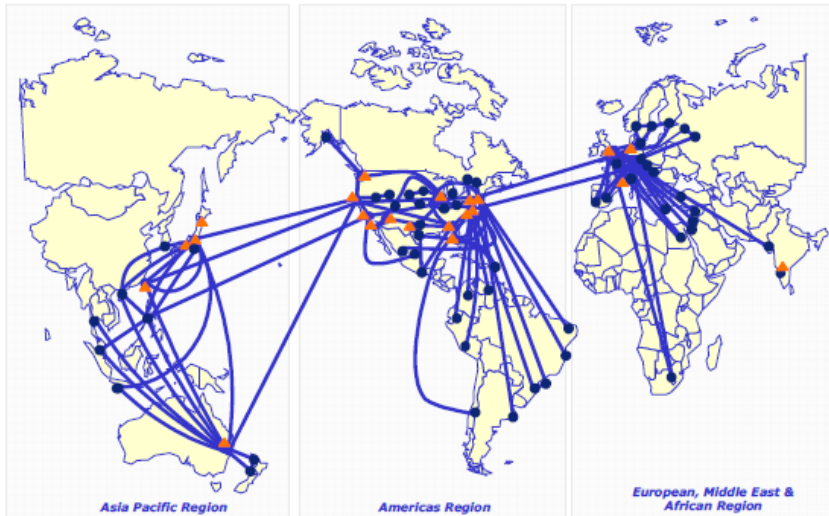

- Directly Integrated with AT&T Global Network
- Access to 41 Data Centers in 11 Countries
- In Region Network Operations and Customer Support Centers

24x7x365 Proactive Monitoring & Management

- Network and Systems
- Server, Facility & NOC Security

Flexible Connectivity Options

- Multi-Carrier
- Burstable to 100 MBPS

Emergency Services

- 30,000 gal. diesel to power eight generators
- VESDA fire suppression system
- 24/7 on-site security force



1,674,650
Monthly Users

13.88 Billion
Annual Site Visits

59,903,412
Number of
Items Dispensed

2.7M+
Messages Per Day

99.9% Uptime

SupplyPro Reports are configurable and can be easily customized

- All reports have a “core” set of columns, filters allow for customization
 - Simple calendar tool for quick date range selection
 - Save filter parameters for easy duplication of on-demand generation
- Reports can be automated and sent at any desired frequency
 - No limit on number of recipients
 - No limit on number of automated reports
 - Pick the file type desired (Excel, CSV, TXT, XML)
 - Send via email or to FTP for simple integrations
- Authorized report listing can be customized by user group

Reports are categorized by type (Consumption, Inventory, Calibration, etc) and range from high level “snapshot” summary views to raw transaction details

- Snapshot reports include “drill down” capability to the details
- Results can easily and immediately be exported to Excel
- Enterprise Reports available for enterprise users

Consumption Reports

- Consumption and Access Snapshot by User
- Consumption by Area
- Consumption By Device
- Consumption by Product and User
- Consumption By User
- Consumption By User And Product
- Consumption By User Group
- Consumption Snapshot by Allocation Code
- Consumption Snapshot by Allocation Code and Product
- Consumption Snapshot by Area
- Consumption Snapshot by Device
- Consumption Snapshot by Product
- Total Consumption by Device
- Total Consumption by Product
- Trend by Device
- Trend by Product
- Trend by User and Product
- Trend by Vendor

Inventory Reports

- Current Inventory
- Inventory Alert Summary
- Inventory Movement
- Inventory Turnover by Part and Device
- Lockdown
- Lot Summary
- Order Maintenance Summary
- Quantity Ordered by Product
- Restock by Device
- Stock Location Information
- Stockout Analysis

Checkout Reports

- Checkout by Allocation Codes
- Checkout Snapshot by Allocation Codes
- Checkout Summary by Product
- Checkout Summary by Serial Number
- Current Check Out and Overdue Status
- Overdue History and Summary

Calibration and Serialized Items Reports

- Calibration Due
- Calibration History
- Serial Number History
- Serial Number History with Allocation Codes
- Serial Number Statistics
- Serialized Item Listing

Discrepancy Reports

- Discrepancy Snapshot by Device
- Discrepancy Snapshot by Product
- Door Open No Transaction by User

Raw Transaction Reports

- Raw Door Open No Transaction Events
- Raw Transactions
- Raw Transactions with Allocation Codes

User Reports

- Product Access By User Group
- User Listing Details
- User Login and Activity
- Users per Operations

System Reports

- Possible Late Polling Devices
- Product Listing

Other Reports

- Gen1 Menu Listing
- Products By Product Access Group
- Storage Location History

Simple “click and select” filter options allow for easy reporting

» Consumption Snapshot by Product Display Report Schedule Report Send Now Return to Report List

Select Date Range

From: 2012-12-12  at: 12:00 AM ▼

To: 2012-12-19  at: 12:00 AM ▼

Scheduling Note
When **scheduling this report**, the date range you enter here will be converted into a "rolling" date range that will be adjusted each time the scheduled report is generated.

Select Filters

Device: All Devices
3X4 SUPPLYLOCKER GEN2
SMARTDRAWER WITH LOCKER
SUPPLYBAY GEN1

Vendor Name (Code): All Vendors
CUTTING TOOL COMPANY (CUTTINGTOOL001)
SAFETY SUPPLIER (SAFETY001)

Area: DEMO ROOM

Show: ALL ▼

Select Sort Order

Sort By: Product Name ▼

Select Optional Columns Select All Select Unit Of Issue Columns Select Unit Of Purchase Columns Select Piece Quantity Columns

<input type="checkbox"/> Product Description	<input type="checkbox"/> Category	<input type="checkbox"/> Purchase Price	<input type="checkbox"/> Price/ piece
<input type="checkbox"/> AltPartNumber1	<input type="checkbox"/> Unit of Issue Quantity	<input type="checkbox"/> Unit of Purchase Quantity	<input type="checkbox"/> Net Qty (pieces)
<input type="checkbox"/> AltPartNumber2	<input type="checkbox"/> Take Qty	<input type="checkbox"/> Net Qty (UoP)	<input type="checkbox"/> Take Qty (pieces)
<input type="checkbox"/> Vendor	<input type="checkbox"/> Return Qty	<input type="checkbox"/> Take Qty (UoP)	<input type="checkbox"/> Return Qty (pieces)
<input type="checkbox"/> SubVendor	<input type="checkbox"/> Current Price	<input type="checkbox"/> Return Qty (UoP)	<input type="checkbox"/> Take Amount
<input type="checkbox"/> Menu Number	<input type="checkbox"/> Unit of Issue	<input type="checkbox"/> Unit of Purchase	<input type="checkbox"/> Return Amount

Select Additional Options

Save Report Settings

See next slide for sample report results

SUPPLYPORT SOFTWARE LICENSE FEATURES

- No additional per user fees with paid license
- Software updates & maintenance, delivered programmatically without interrupting users or IT staff
- 24/7 network communications monitoring & automated systems polling
- Hosted service in an enterprise-class data center
- Introductory version of SmartGuide in-app help for users and administrators
- Worldwide access to admin & reporting functions
- Data retention



Indirect Material Consumption Reduction

- 15% to 30% Savings consistently
- Reduced/Eliminate employee stashes/hoarding



Compliance & Control

- Increase compliance and accountability
- 24/7 automated access to critical supplies
- Cost tracking and allocation



Labor Productivity Gains

- Reduced travel time
- Increased production time
- Reduced staffing requirements

Reduced Procurement Costs

- Automated re-ordering: Internal & External
- Reduce/Eliminate redundant data entry
- Reduce Expedited orders and Stock Outs



Inventory Solutions Architects

- 4 full time ISA's

Data Analysis

- System Recommendation and Configuration
- Product specific test vending

Configuration Design: Built specific to location requirements

- Customized configuration tools
- Maximizes cabinet real estate for stocking and inventory
- Sales Layout and Design PPTs

SupplyPort Webinar Support

- Customer overviews
- Customer specific application & workflow

SupplyPro Demo Center Support

- Customer facing Demo support: HW & Software
- Sales and Certification Training
- Cincinnati and San Diego

Total Project Management – Turnkey Approach

- Single point of contact with assigned PM
- Project Manager assigned at time of order to each sale
- Project Managers manages process from receipt of order to installation and implementation event
- PM process defined and documented via Microsoft Dynamics

Project Management Support

- Coordination with Reseller interface if required
- Software Configuration Support
- Badge Testing and Verification
- Network Readiness Support
- Shipping & logistics Support
- Advanced and Post Installation Training Support

SupplyPro Field Engineers perform actual events

- Inspect and Install all devices
- Conduct on-site diagnostics & testing
- Provide on-site loading support
- Provide on-site training on both hardware & software –Admin
- Provide basic on-site training with select Users

Post-Installation Service & Support provided by SupplyPro

CRM Software for Service and Support Tracking

- Microsoft Dynamics
- Case # assigned to track each call and email

National Customer Support Center provides live telephone support

- 7AM to 8PM EST
- Answering Service for after hour support
- 96.11% of calls answered live: average wait time 35 seconds
- Calls routed to voicemail returned within 1 hour during std. hours

On-Site Technical Diagnosis and Repair

- Requests prior to 3PM EST; we can provide next-day on-site service
- Problem resolution 69.74% on the 1st visit.

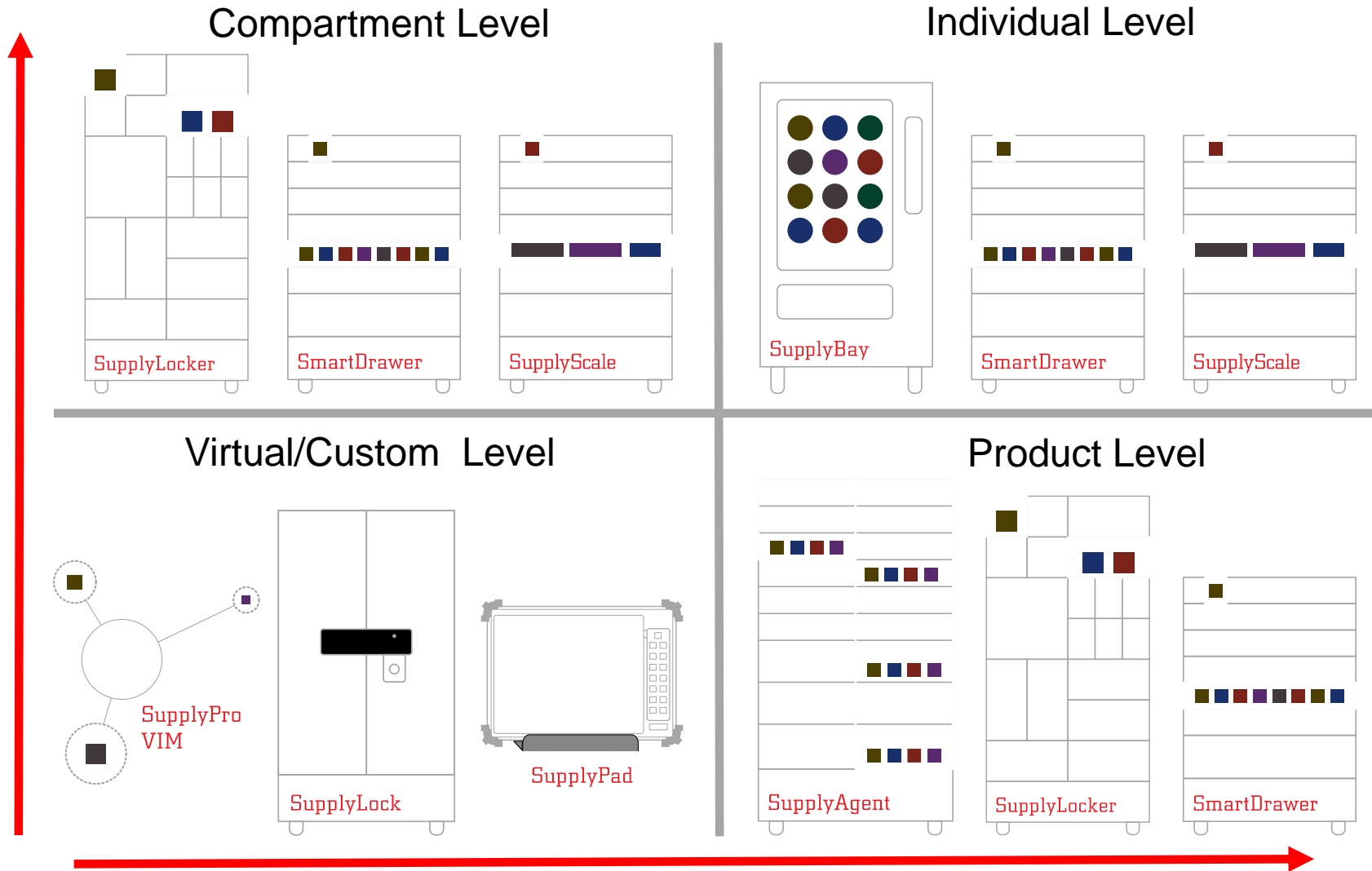

Levels of Control

- Absolute; Part Number; Door Level/Multi-SKU
- What's driving the requirement?
 - Nature of product vs. emotional decision?
 - Control, accountability
 - Automated order management & restocking
 - Usage visibility
 - Asset management & tracking
- Absolute control = higher investment and footprint
- Individual point of use locations
- Multi-department shared use
- Restricted by user/department/craft/etc
 - May impact required level of control

Employee Log-In Options

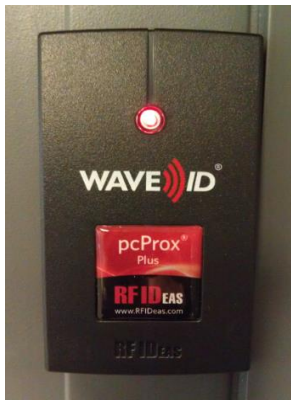
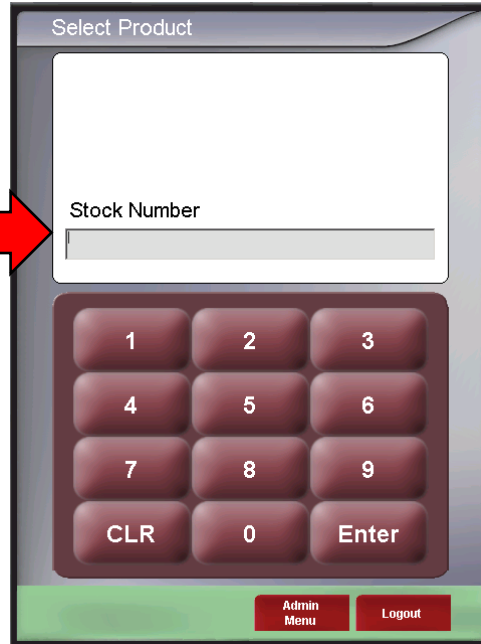



Direct and Indirect (MRO) Materials

- Absolute control device
- 24/7 secured access
- Clear Lexan door w/LED Lighting
- **Co-locate with other SupplyPro systems**
 - Auxiliary SupplyBays
 - SupplyLocker, SmartDrawer

Specifications

- Maximum 70 sku's/average 45 sku's
- Maximum weight per tray = 100 lbs
- Industrial Grade: Reinforced Steel
- **Unique Swivel Keypad for ease of refill**
 - Supports Rapid Refill
- Avg. 5-7 year life span





- 22" depth
- Stand-alone or locate with other SupplyPro units
- LED Lighting for Clear Doors
- Solid Steel Inserts to create Solid Door
- Panel knock-outs for charging inside door (option)

Door Configurations



1-door



2-door horizontal



2-door vertical



4-door



6-door



Specialized Reporting and Notification

- Loan period assignments
- Checked Out Item reporting
 - By employee/By Product
- Overdue Notification & Prompting
- Calibration Date Notification
- Plant-wide visibility

- 24/7 secured access
- Flexible, modular configuration
- Tool check-in/check-out
- Tool serialization & calibration mgmt.

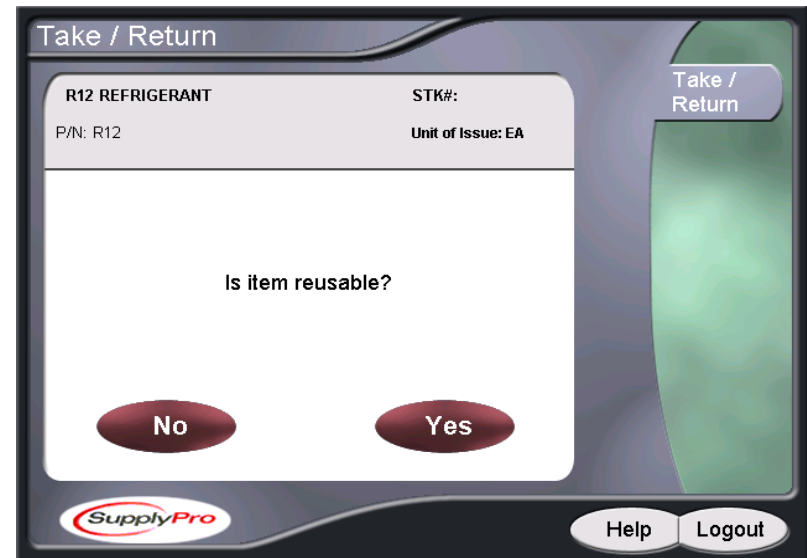

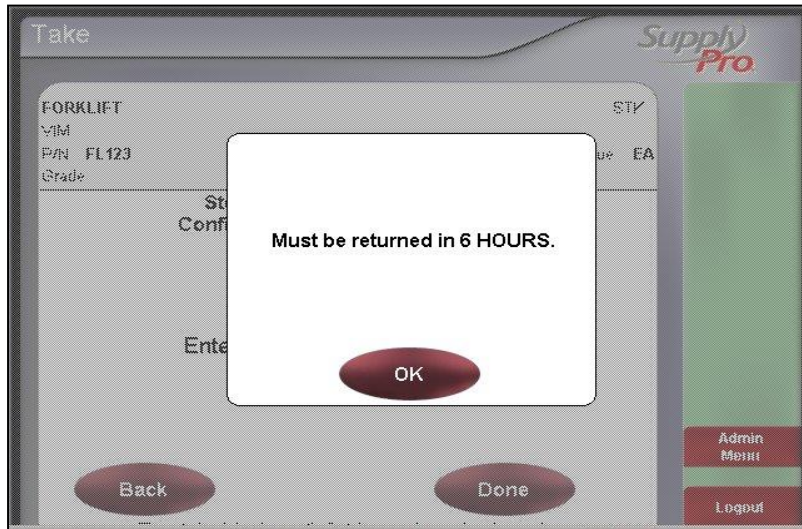

Loan Period

- If a Loan Period has been applied to the product, at Check Out the screen will display the expected period for when the product is expected for return
- **If the user does NOT return the tool within the specified period, the system may send an overdue email alert to the administrator**

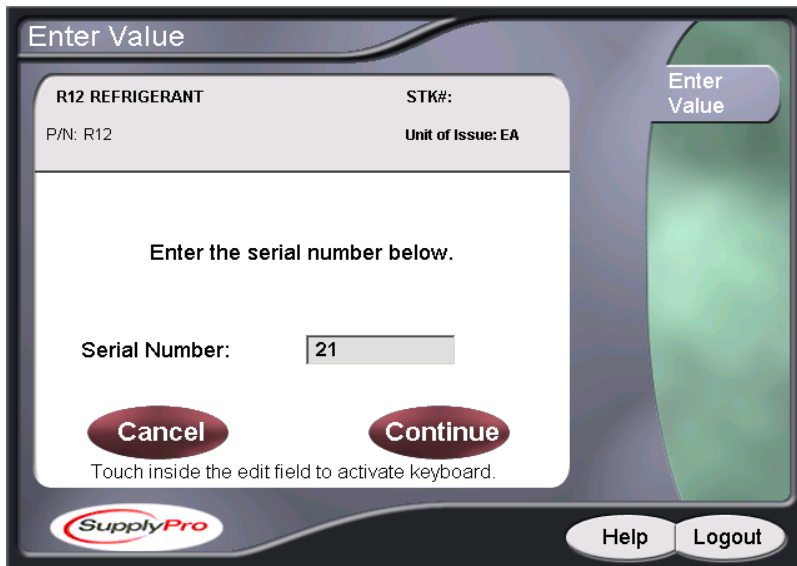

Check In of a SERIALIIZED Item

- When a user attempts to Check In a serialized item that is NOT on their current checkout list, the user is prompted to enter the SERIAL #
- **If Serial number is NOT valid for the Check In / Return transaction – user will receive error.**
- **Serialization requires that a specific serial number be Checked In and Out of a single designated location.**

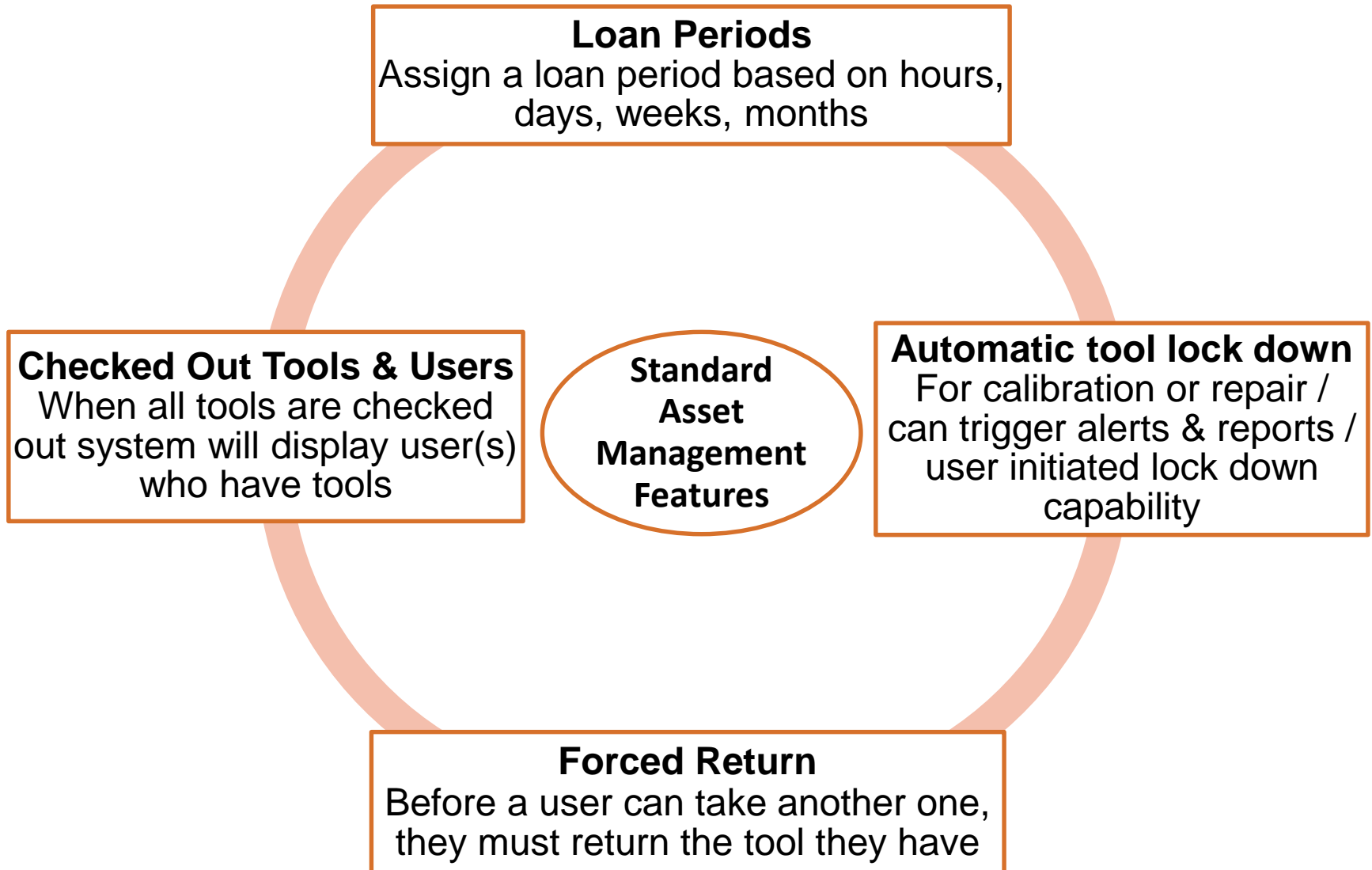

Empowering existing cabinets to provide **Smart Storage**, delivering inventory control and automated procurement

Direct and Indirect (MRO) Materials

- Retrofit to shop floor cabinets or add to new cabinets
- Pick to light design for ease of use
- Take and return capability per lid
- Supports rapid refill for ease of reloading.

Inventory Examples

- Calibrated/shared/certified/tools
- Inserts & cutting tools
- Parts/components: maintenance
- Instruments/gauges
- Consumables

Specifications

- 9 lid configurations: 2, 4, 8, 12, 16, 24 & 24L, 36, 48



- Cutting tools
- Sensors, Switches
- Instruments & gauges
- Welding Supplies
- Hand and power tools
- Calibrated/certified tools
- FOD tools
- Production parts
- Shop supplies
- Maintenance items
- Safety supplies
- Parts, components
- Hand-held radios
- Keys



24 Lid Cover



16 Lid Cover



12 Lid Cover



8 Lid Cover

Key Market Differentiators:

- Start with a single drawer and grow as needed
- Retains full product control with single SKU access
- Eliminates common phantom dispenses in other platforms
 - Isolated weight and measurement at bin level
 - Simple set up and loading
 - Minimum calibration requirement
- Standard SupplyScale – 5 gram
 - Precision Scale ~ 1 gram

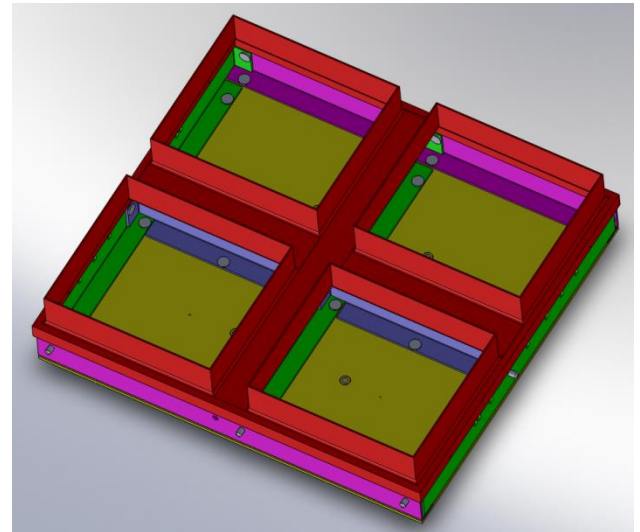
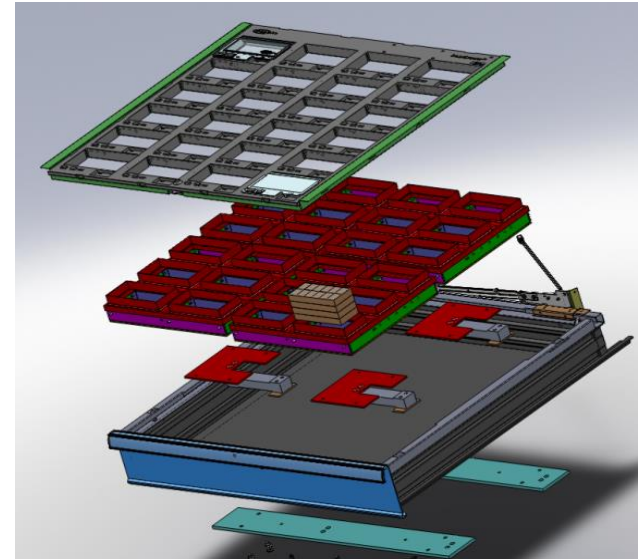

Using industry leading weight based sensing technology & Secure Bin™, SupplyScale seamlessly integrates productivity, quality, compliance and safety into a single, complete point-of-use solution.

Features

- Extremely accurate, accountable & easy to manage
- Replenishment time is significantly reduced
- Drawer level flexibility tailored at the lid / bin / compartment
- Faster material access & restocking time
- Inventory automatically adjusted upon completed transaction

- New or retrofit existing Lista SmartDrawer cabinets
 - Multiple cabinets per Scale Controller



Features

- Mix /match with SupplyPro units
- Drawer / door / shelf security
- Retrofit onto existing cabinets
- Connects to SupplyLink
- Manage multiple sub-locations
- Installed horizontal or vertical

Applications

- Hazardous materials
- Large, heavy equipment
- Lab supplies
- Specialty instruments



Incorporate into a classic SmartDrawer cabinet or retrofit onto existing storage units.





Engineering Services:

- Custom reports and ERP system integration
- Custom software development
- Custom hardware development

Professional Services:

- Preventative Maintenance
- Add-ons, expansions, and system migrations and upgrades
- Client report card
- Hardware and Software Client Branding
- Marketing Services – Collateral Co-branding

- **Product Costs**
 - Purchase and Lease Options Available
- **Annual Software License Fee**
 - License to SupplyPro's proprietary SupplyPort software
 - Web based administration + automated order management management
 - Automatic software enhancements & maintenance
 - Disaster recovery, system back up & restoration
 - Warranty = 1 year parts + 90 days labor for new systems
 - Warranty = 90 parts only on Refurbished systems
 - Per connection versus per machine
- **Installation, Implementation & Training**
 - Installation = % of product fees + site visit
 - multi-unit discounts apply
- **Shipping Costs**
- **Lease Options Available**
- **New EasyPay Program - 2016**

SupplyPro utilizes a data network organization of over 700+ data engineers for additional and local support for on-site visits.





Next Steps