



COMPLETE METALWORKING SOLUTIONS

(800) 991-4225

www.ahbinc.com

ISO Certified

customerservice@ahbinc.com

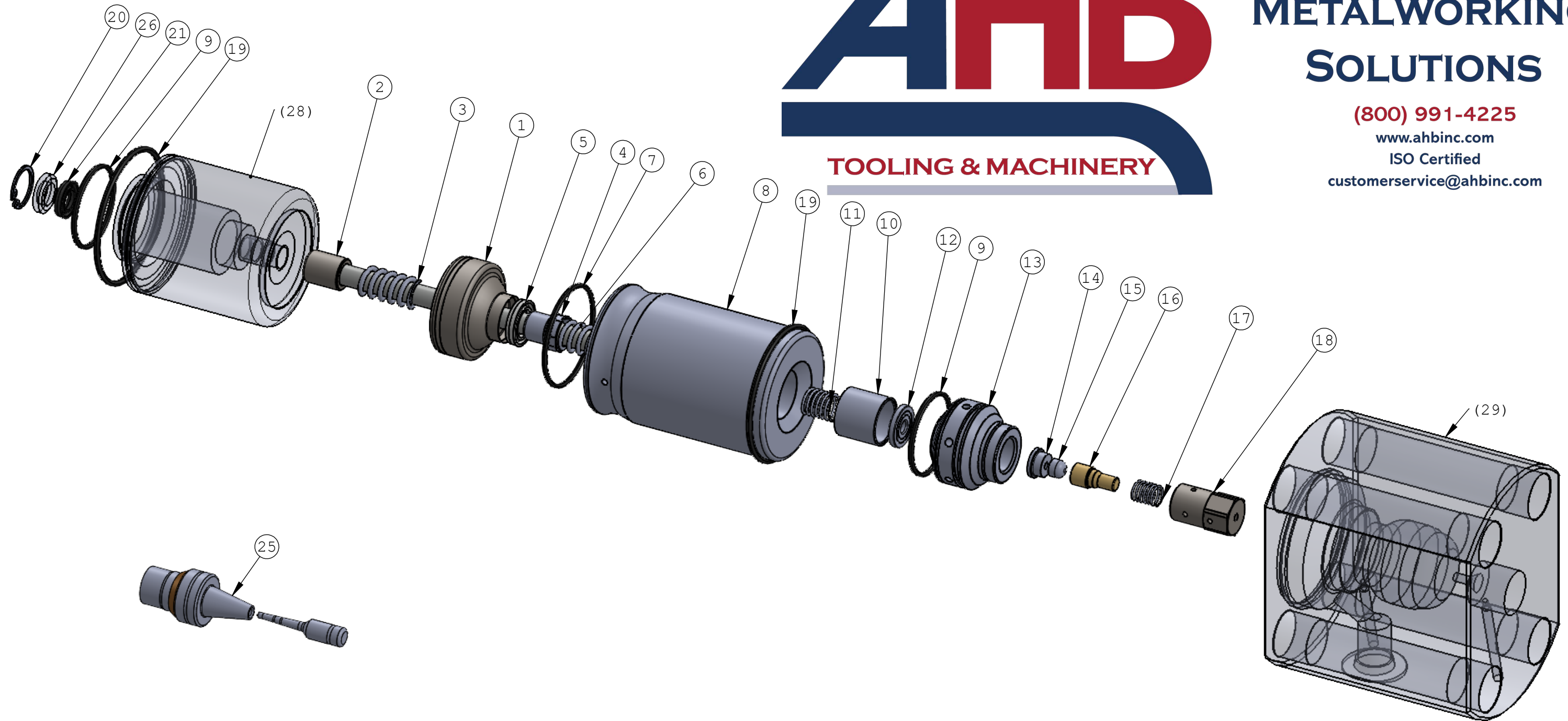

<p>HIGHLY CONFIDENTIAL PROPRIETARY INFORMATION</p> <p>THIS DRAWING AND ALL INFORMATION CONTAINED THEREON IS CONSIDERED PROPRIETARY AND MAY NOT BE USED FOR MANUFACTURING OR FABRICATION PURPOSES WITHOUT PERMISSION FROM HYPERTHERM, INC.</p>				<p>305 2ND ST NW STE 115 NEW BRIGHTON, MN 55112 PHONE: 651-294-8600 FAX: 651-294-8620 EMAIL: WATERJET@HYPERTHERM.COM WEB: WWW.HYPERTHERM.COM</p>		<p>TITLE: HYPLEX PRIME MAJOR REPAIR KIT</p>		
	<p>NAME</p>	<p>DATE</p>	<p>MATERIAL</p>	<p>SHEET 1 OF 2</p>	<p>SCALE: 2:3</p>	<p>FINISH</p>		
<p>DRAWN</p>			<p>HARDNESS</p>	<p>SIZE B</p>	<p>DWG. NO. 1-18976</p>	<p>REV</p>		
<p>CHECKED</p>			<p>WEIGHT</p>					
<p>ENG APPR.</p>								

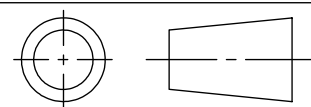

ITEM NO.	PART NUMBER	DESCRIPTION	QTY	FLOW #	KMT #
1	1-18875	SEAL CARRIER:ASSY	3	A-0265-062	72185226
2	1-18883	PLRG ASSY:5/16 DIA	3	011045-1	72186914
3	1-18753	SPR:COMPRESSION 336 ID	3	A-12218	72186940
4	1-18862	SEAL:DYN	3	011051-1	72185177
5	1-18749	ROD SEAL:DISOGRIN 005-033	3	A-00621-33	72185125
6	1-18748	SPR:COMPRESSION 362 ID	3	A-12217	72186948
7	1-11679-029	O-RING:70 DURO BUNA -029	3	A-0275-029	5122007
8	1-18872	CYL:HP	3	049584-1	72185325
9	1-11679-025	O-RING:70 DURO BUNA -025	6	A-0275-025	10074383
10	1-18864	FLR TUBE:SLV	3	011350-1	72185149
11	1-18747	SPR:COMPRESSION 352 ID	3	A-12219	72185141
12	1-18865	PPT:INL	3	011042-1	72185133
13	1-18861	BODY:CHK VALVE	3	049578-1	72185307
14	1-18867	OUT PPT:SEAT	3	011041-1	72185192
15	1-18869	PPT:OUTLET	3	011039-1	72185185
16	1-18868	OUT PPT:GDE	3	011040-1	72185167
17	1-18752	SPR:COMPRESSION 322 OD	3	A-9223	72185200
18	1-18870	CAGE:OUT	3	006732-1	Not listed
19	1-11679-033	O-RING:70 DURO BUNA -033	6	A-0275-033	204334082
20	1-18745	RTNG RNG:5/8 IN	3	A-0265-062	72185226
21	1-11993	U CUP SEAL	3	A-00720-31	72185208
22	1-11447	GRS:5 G HIGH VAC	1	A-4689	10087385
23	1-18750	ANTI-SEIZE:7 G	2	A-20386-1	49832199
24	1-18882	PCV:ASSY	1	042145-2	72185250, 72185258, & 72185276
25	049797-1 PLUNGER NUT	<FOR REFERENCE>			
26	011054-1 SEAL SPACER	<FOR REFERENCE>			
27	049585-1 SUBPLATE ADAPTER	<FOR REFERENCE>			
28	049887-1 END CAP	<FOR REFERENCE>			

<p style="text-align: center;">HIGHLY CONFIDENTIAL PROPRIETARY INFORMATION</p> <p style="text-align: center;"><small>THIS DRAWING AND ALL INFORMATION CONTAINED THEREON IS CONSIDERED PROPRIETARY AND MAY NOT BE USED FOR MANUFACTURING OR FABRICATION PURPOSES WITHOUT PERMISSION FROM HYPER THERM, INC.</small></p>				<p style="text-align: center;"><small>305 2ND ST NW STE 115 PHONE: 651-294-8600 NEW BRIGHTON, MN 55112 FAX: 651-294-8620 EMAIL: WATERJET@HYPERTHERM.COM WEB: WWW.HYPERTHERM.COM</small></p>			<p style="text-align: center;">TITLE: HYPLEX PRIME MAJOR REPAIR KIT</p>		
			NAME	DATE	MATERIAL	SHEET 2 OF 2	SCALE: 2:3	FINISH	
			DRAWN						
		CHECKED			HARDNESS	SIZE B	DWG. NO. 1-18976	REV	
		ENG APPR.			WEIGHT				