



# AHB

TOOLING & MACHINERY, INC.

COMPLETE METALWORKING SOLUTIONS

(800) 991-4225

[www.ahbinc.com](http://www.ahbinc.com)

ISO Certified

[customerservice@ahbinc.com](mailto:customerservice@ahbinc.com)



CUSTOMIZABLE  
CUTTING HEAD SOLUTIONS

WITH DIALINE FROM ACCUSTREAM

DIALINE CUTTING HEADS



**PRECISION**  
POWER FOR EVERY PURPOSE

- Faster** cutting speeds
- Reduced** edge taper
- Increased** production
- Lowest** hourly cost of operation

**The industry's FIRST customizable cutting head!**

AccuStream has spent countless hours developing the industry's most comprehensive, smartly designed and completely customizable cutting heads available today. The DialLine cutting head has taken stream alignment to the next level and backs it up with an industry best 600 hour warranty. Not only is DialLine the most technologically advanced cutting head on the market but the DialLine also offers you the ability to customize the cutting head to meet the needs of your operation. If you want 1000 hours of worry free cutting you need to have the DialLine cutting head in your arsenal.

**What sets Dialine apart**

**1 DIAMOND ORIFICE**

- Secure precision diamond engagement produces concentric stream alignment to the nozzle
- Removable diamond mount provides maximum flexibility for a variety of cutting applications
- Best warranty in the industry (600 hours)

**2 MIXING CHAMBER**

- Produced from the most wear resistant material for abrasive waterjet
- Anti-turbulent design reduces wear, protects diamond and optimizes abrasive usage
- Easy access allows for periodic inspection and replacement (if required)

**3 NOZZLE NUT**

- Designed with dual piloting diameters precisely center the cutting stream to the carbide nozzle
- Long life Diamond orifices and precise nozzle alignment increase nozzle longevity by as much as 15%
- Trouble-free removal of broken nozzles due to part "pop ups" or nozzle "touchdowns"

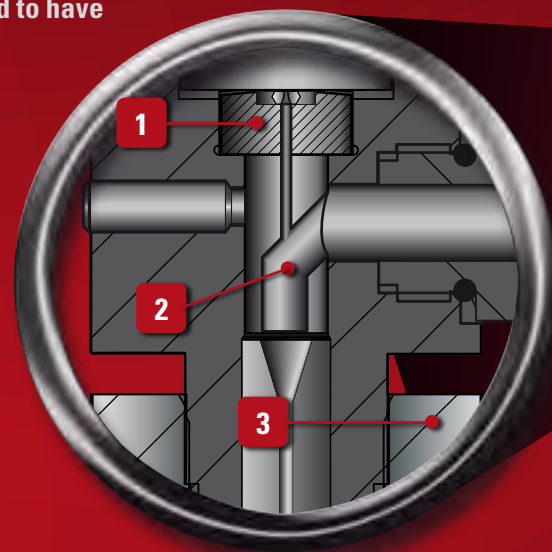

.300 DialLine shown with 3/16" Inlet, 3" nozzle and protective spray guard. 13904-1-2-2



.281 DialLine shown with 3/8" Inlet, 3" nozzle, protective spray guard and 13841 swivel adapter. 13904-2-1-2

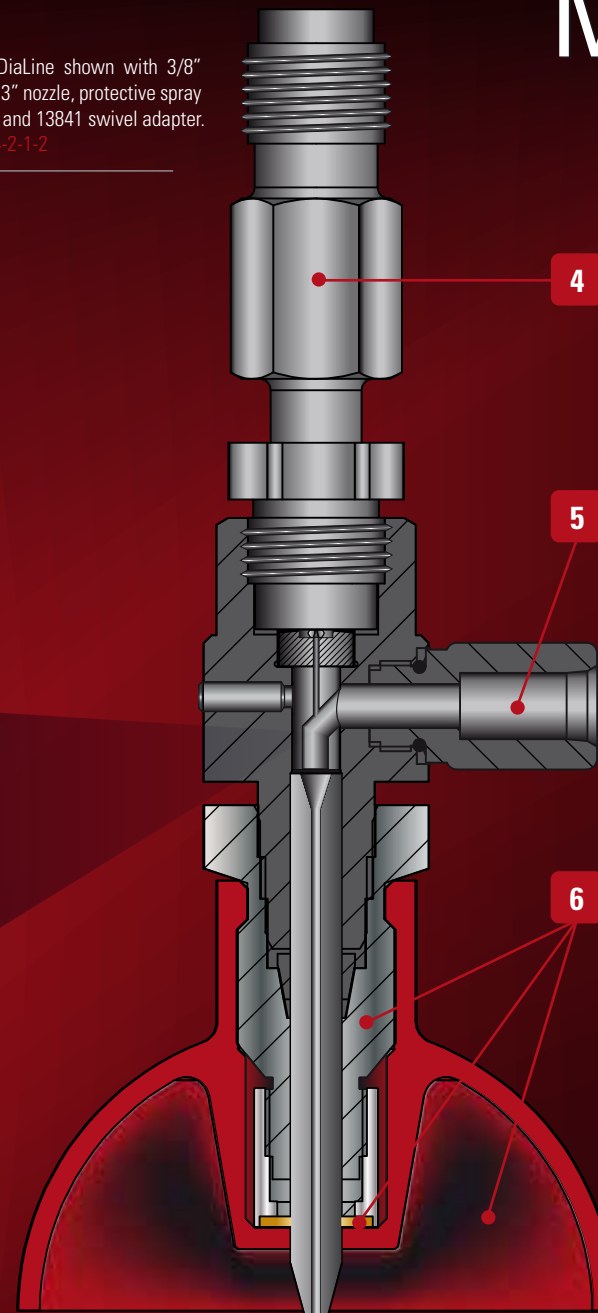

Making the best **BETTER**

**What we've improved**

**4 HEAD CONNECTIONS** NEW

- New adapter connections provide the ability to rotate the abrasive inlet enabling perfect placement
- Range of adapter configurations available to easily mount DialLine to any waterjet system

**5 ABRASIVE INLET** NEW

- Optional 3/16" abrasive inlet enable simple connection to smaller abrasive feed lines
- Optional Dual inlet (not shown) makes vacuum assist cutting possible for low pressure piercing of brittle materials

**6 NOZZLE OPTIONS** NEW

- Three nozzle nut options allows for custom cutting head configurations (standard, 3" guard and 4" guard)
- Nozzle guard design significantly reduces wear and protects the cutting head
- Second carbide lined nut provides maximum protection and wear resistance (replaceable)

**DIALINE vs. STANDARD RUBY HEAD**

The chart below illustrates the average cost of operating a DialLine cutting head over a 1200 hour period as compared to a standard ruby orifice cutting head.

	Average Life		Per 1200 hrs		Average Cost		Extended	
Orifices	40	1200	30	1	\$15.00	\$425.00	\$450.00	\$450.00
Nozzles	60	70	20	17	\$85.00	\$85.00	\$1,700.00	\$1,445.00
Cutting Head	2000	1200	.06	1	\$300.00	\$340.00	\$180.00	\$340.00
							\$2,330.00	\$2,210.00

■ Ruby ■ Dialine

In 1200 hours the cutting process will never be interrupted due to a blown orifice. In fact, nozzle life increases by as much as 15% due to a perfectly aligned stream. Using a DialLine Cutting Head, there is no more struggling with poor cutting stream and having to worry if important parts will be damaged due to failed orifices. The DialLine is your assurance of maximum cutting performance and prolonged up-time!



# Completely **CUSTOMIZABLE**

When choosing a DiaLine you are not limited to one style or configuration. DiaLine allows you to customize your cutting head to meet the specific needs of your operation. Not only will you have a cutting head that exceeds all expectations but a cutting head that also works seamlessly with your system and allows you to operate at peak performance.

## Build your *DiaLine*

### 1 CHOOSE YOUR ABRASIVE BODY

Choose from .281, .300 or .281 Dual Inlet Abrasive body's

### 2 CHOOSE YOUR INLET

Choose from 3/8" (Standard) or 3/16" for smaller abrasive feed lines

### 3 CHOOSE YOUR NOZZLE NUT

Choose from the standard, 3" nozzle nut or 4" nozzle nut

## Complete the Package

### CHOOSE YOUR CONNECTION

Choose from standard or swivel adapters for any system

### CHOOSE YOUR ORIFICE

Choose from Diamond (.008-.018) or Ruby (.004-.020) orifices

### CHOOSE YOUR PROTECTION

Choose from 1/4" or 3/8" Thimble Filters for added protection and 600 hr. extended warranty



For purchasing information or to download the DiaLine Buyers Guide visit [accustream.com](http://accustream.com)



309 5th Avenue NW  
New Brighton, MN 55112

Phone: 866-566-7099  
Fax: 651-294-8620

Email: [sales@accustream.com](mailto:sales@accustream.com)  
Web: [www.accustream.com](http://www.accustream.com)