

Introducing the DiaLine4™ cutting head

Direct replacement for the Flow Paser 4



What makes AccuStream parts better?

From our first introduction of the DiaLine cutting head, AccuStream has continued to improve and strengthen the design. The new DiaLine4 is built with the same rigorous engineering used in our DiaLine cutting heads today. The DiaLine4's patent-pending cutting head technology is engineered to be a direct replacement for the Flow Paser 4 cutting head, requiring no additional configuring.



COMPLETE METALWORKING SOLUTIONS

(800) 991-4225

www.ahbinc.com

ISO Certified

customerservice@ahbinc.com

DiaLine4

DiaLine4™ replaces the Flow Paser 4 cutting head with no additional configuration needed while providing precision alignment of the stream from the orifice to the nozzle for increased nozzle life, better cuts, and reduced costs.

Mixing chamber

- Made from long-life carbide material
- Easy access allowing for periodic inspection
- Replaceable mixing chamber, allows the abrasive body to be used for longer, saving cutting head replacement costs

Abrasive inlet

- Single, 3/8" (1 cm) ID abrasive inlet

Nozzle nut

- Integrated O-ring to provide easier maintenance and protection against abrasive in the threads
- Accommodates .281, 4" (10.2 cm), non-ringed nozzles
- Provides precision alignment of the stream from the orifice to the nozzle for increased nozzle life, better cuts, and reduced costs

Splash guard

- Reduces jet splash-back to the cutting head
- Included blast disc insert protects against accelerated wear

Diamond orifice (not included)

- Precision diamond produces concentric stream alignment to the nozzle
- Removeable diamond allows flexibility for a variety of cutting applications
- Industry-leading 600-hour diamond warranty with use of a thimble filter

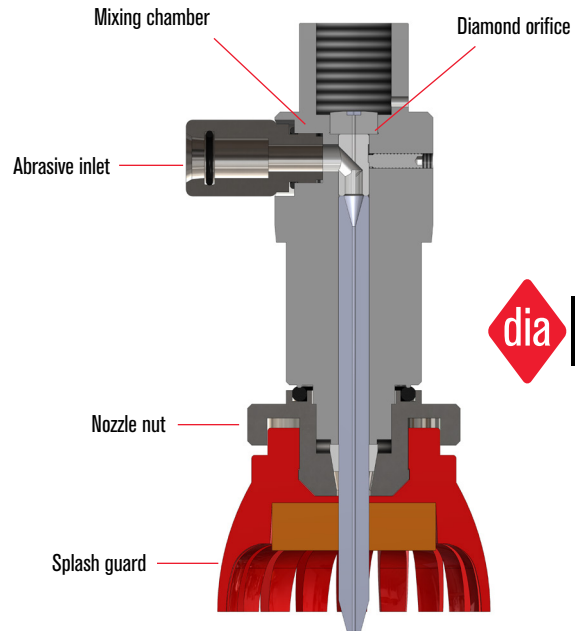

Ordering information

DiaLine4 cutting head	
1-18741	DiaLine4 complete assembly
DiaLine4 parts	
1-11357	Collet
1-11679-212	O-ring, -212
1-12747	Mixing chamber
1-12752	3/8" (1 cm) abrasive inlet
1-12836	Set screw
1-14465	Blast disc
1-18717	Nozzle splash guard
1-18718	Abrasive body
1-18719	Nozzle nut
DiaLine4 orifices	
1-12749-XXX	Diamond orifice (recommended)
1-22835-XXX	Ultra sapphire orifice
1-12835-XXX	Ruby orifice
DiaLine4 nozzles	
1-12779-XXX-40	.281 Nozzle, Roctec 100
1-11277-XXX-40	.281 Nozzle, Roctec 500

For information, contact your local AccuStream partner or customer service at: 1-800-991-4225

Hypertherm, AccuStream, and DiaLine are trademarks of Hypertherm, Inc. and may be registered in the United States and/or other countries. All other trademarks are the properties of their respective owners.

Environmental stewardship is one of Hypertherm's core values, and it is critical to our success and our customers' success. We are striving to reduce the environmental impact of everything we do. For more information: www.hypertherm.com/environment.



©10/2019 Hypertherm, Inc. Revision 0
897800

Hypertherm[®]
SHAPING POSSIBILITY[®]

