

HyproJET – solutions for waterjet cutting

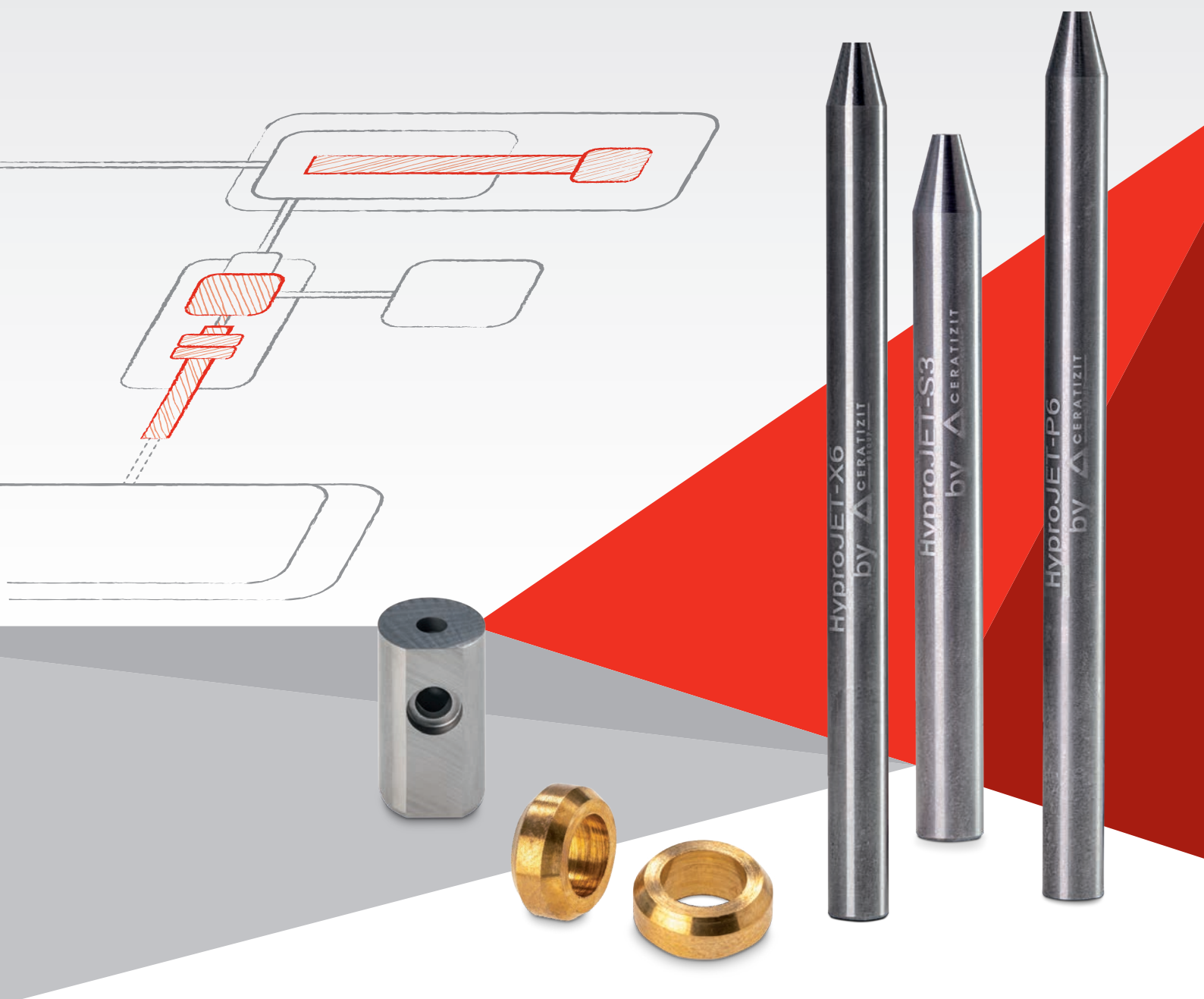

CERATIZIT is a high-technology engineering group specialised in cutting tools and hard material solutions.



Tooling a Sustainable Future

ceratizit.com



Together towards profitable growth: we can give you the decisive competitive advantage.

Precise waterjet cutting

Waterjet cutting enables the **precise and burr-free cutting** of a variety of materials in industrial-scale production.

CERATIZIT offers you three waterjet nozzle product lines for this application – **HyproJET X6**, **HyproJET P6** and **HyproJET S3**. Particularly **wear-resistant carbide grades protect the waterjet nozzles** from erosion by abrasive materials in the waterjet.

On request our waterjet nozzles are also available with either integrated or separate mixing chamber to suit your preference. In addition, we offer customised catcher cups and plungers, based on drawings, in wear-resistant carbide grades.

Environmentally-friendly abrasive cutting can be used in the machining of harder materials such as **stone**, **metals**, composite materials or **glass**.



Advantages and benefits

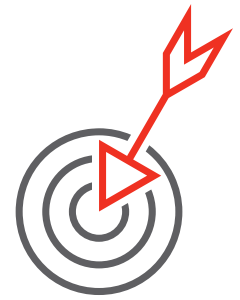

Advantages

3-line concept with optimal price-performance ratio; customer-specific special solutions can also be supplied on request

Suitable for all modern cutting head systems; supports automatic centring when clamping the tube

Long tool life and repeatability of the new X6 product

All process phases from a single source, from the carbide powder to the ready-to-use solution

Close hole tolerances, perfect grind and concentricity

High product availability, orders 24/7 via the online shop

Worldwide service and sales

Benefits

> The right solution for every application

> Particularly flexible and economical

> Minimised machine downtime resulting in maximum productivity

> Top-class product quality, precision and performance at the highest quality level

> Precise working results

> Quick and flexible delivery

> Comprehensive technical advice



Our carbide grades

Our top-quality and individually coordinated carbide grades withstand maximum pressures and are very resistant to wear.

Because we are able to offer the entire process chain from a single source – from the production of the raw materials and mineral ores to the composition and ongoing further development of the carbide powder – we can guarantee you supreme quality at all times.



CERATIZIT grade code	Binder [%]	Density [g/cm ³]	Hardness [HV10]	Compressive strengths	
				[MPa]	[P.S.I.]
UMG1	0.40	15.55	2675	13000	348000
CTN01L	0.25	15.60	2825	13500	290000



Three product lines for improved economic efficiency

Waterjet nozzles are particularly stressed by the severe erosion of the abrasive during waterjet cutting.

CERATIZIT has developed improved wear protection for this. Constantly high cutting quality is achieved thanks to our optimised carbide grades. To ensure that you always receive the optimal solution for your application, we have developed **3 innovative lines** for you based on state-of-the-art manufacturing technology:

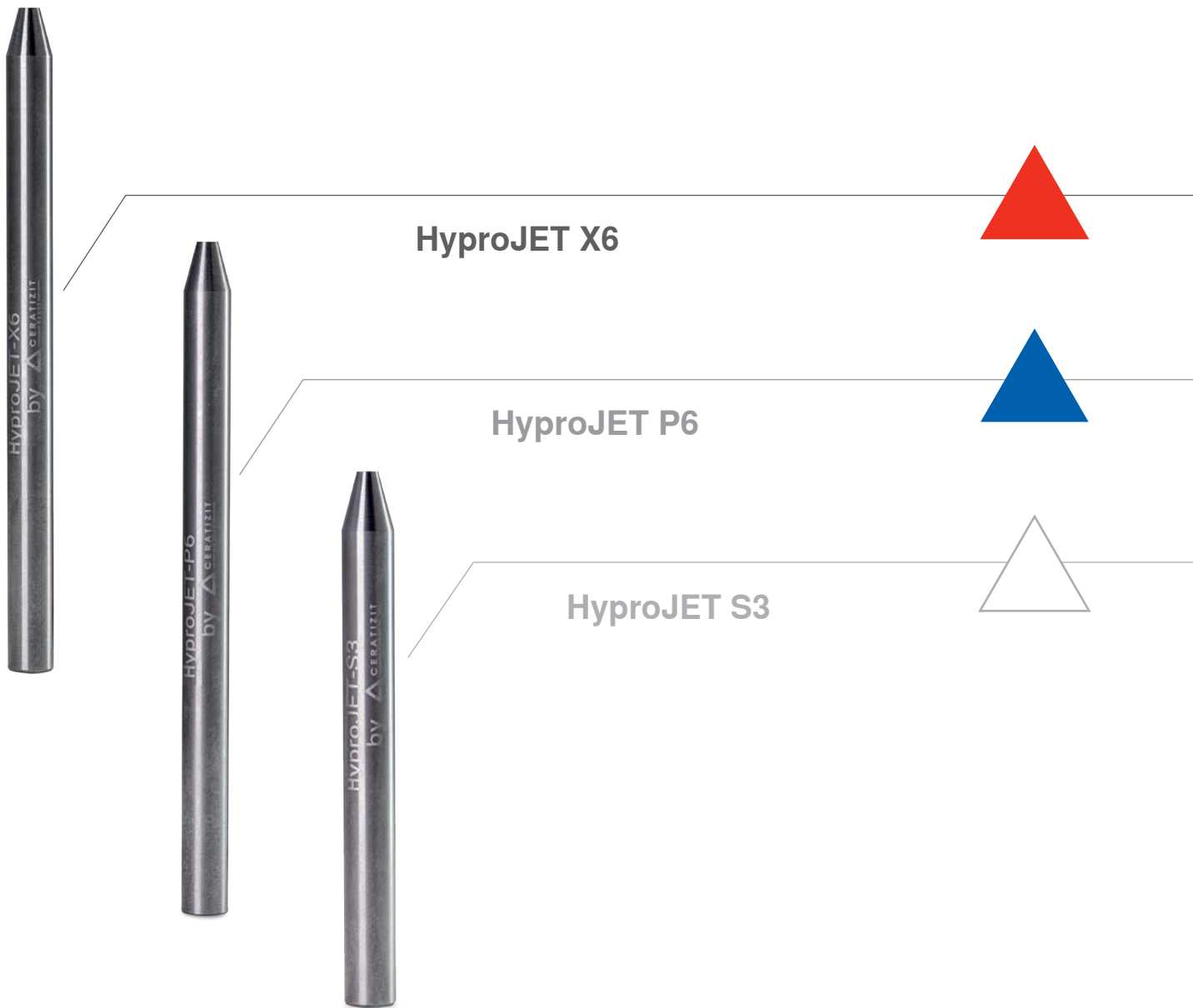

Ordering description for waterjet nozzles

X6 - 0714 - 102 - 0762 - 25 - 15R - CTN01L

Type

External diameter

Internal diameter

Length

Type

External taper

Grade

X6

P6

S3

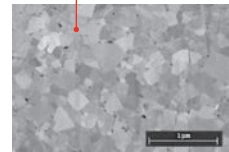
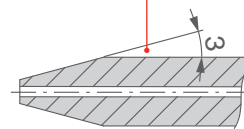
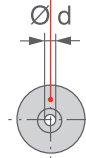
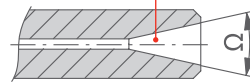
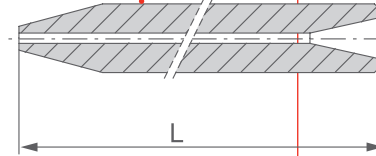
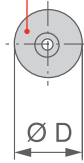

15 = angle
 ...R = ring
 ...S = special
 ...M = mixing chamber
 ...Q = quadrilateral

HyproJET X6

X6

The **X6** is based on an improved design which enables to increase cutting performances leading to better lifetime and smoother cutting quality. This nozzle is suited to cut through technical pieces which need precise finishing quality like hardly machinable ceramics or composites parts.

The longer cutting lifetime allows to reduce maintenance costs and increases the productivity. Its ingenious design also helps to improve the abrasives flow inside the nozzle, reducing issues linked to turbulences phenomena and to reduce total abrasive consumption.

Technical specifications

- ▲ Longer lifetime: +20%
- ▲ Quieter: -3 dB
- ▲ Better finishing:
 - ▲ R_z -40% compared to equivalent water jet nozzle on the market with same cutting conditions
 - ▲ Premium metalurgy: grade CTN01L
 - ▲ 2800 HV10
 - ▲ K_{Ic} (toughness): 7.2 MPa·m^{1/2}
 - ▲ Packaging made with 100% recycled plastic
- ▲ Constant wear for a stable cutting process

Product portfolio

Type, description	Material	D mm	d mm	L mm
X6 0635-076-0762-32-15 CTN01L	14833761	6.35	0.76	76.2
X6 0635-102-0762-32-15 CTN01L	14833764	6.35	1.02	76.2
X6 0714-076-0762-32-15 CTN01L	14833766	7.14	0.76	76.2
X6 0714-076-1016-32-15R CTN01L	14833767	7.14	0.76	101.6
X6 0714-102-0762-32-15 CTN01L	14833768	7.14	1.02	76.2
X6 0714-102-1016-32-15 CTN01L	14833770	7.14	1.02	101.6
X6 0797-076-1016-32-15 CTN01L	14833771	7.97	0.76	101.6
X6 0714-102-1016-25-15-S CTN01L	14833772	7.14	1.02	101.6
X6 0900-076-0762-40-15M CTN01L	14833774	9.00	0.76	76.2
X6 0714-102-1016-32-15R CTN01L	14833775	7.14	1.02	101.6
X6 0797-102-1016-32-15 CTN01L	14833776	7.97	1.02	101.6
X6 0714-076-1016-32-15 CTN01L	14833779	7.14	0.76	101.6
X6 0714-089-1016-32-15 CTN01L	14833780	7.14	0.89	101.6
X6 0900-102-0762-40-15M CTN01L	14833781	9.00	1.02	76.2
X6 0635-102-1016-32-15 CTN01L	14833782	6.35	1.02	101.6

* The tool life varies according to the operational and working conditions of th customer requirements, for example with regards to the material to be cut, the wall thickness, the mounting of the nozzle, the throughput, etc.

HyproJET P6

P6

The **P6** represents a further development of our Premium-Line. P6 is perfectly suited for demanding cutting applications, for example with technical and compound materials, split cuts or precision cuts.

Long tool life and reliability of the waterjet nozzles ensure minimum machine downtime, and thus maximum productivity and cost savings.

Technical specifications

- ▲ Grade CTN01L
- ▲ Successor of the Premium nozzles
- ▲ All surfaces ground
- ▲ Wire-eroded internal diameter
- ▲ Packaging made with 100% recycled plastic
- ▲ Customised variants possible on request

Extract from our product portfolio (additional dimensions upon request)

Type, description	Material	D mm	d mm	L mm
P6 0635-076-0762-32-15 CTN01L	14833458	6.35	0.76	76.2
P6 0635-102-0762-32-15 CTN01L	14833459	6.35	1.02	76.2
P6 0714-076-0762-32-15 CTN01L	14833460	7.14	0.76	76.2
P6 0714-076-1016-32-15R CTN01L	14833461	7.14	0.76	101.6
P6 0714-102-0762-32-15 CTN01L	14833463	7.14	1.02	76.2
P6 0714-102-1016-32-15 CTN01L	14833466	7.14	1.02	101.6
P6 0797-076-1016-32-15 CTN01L	14833467	7.97	0.76	101.6
P6 0714-102-1016-25-15-S CTN01L	14833469	7.14	1.02	101.6
P6 0900-076-0762-40-15M CTN01L	14833471	9.00	0.76	76.2
P6 0714-102-1016-32-15R CTN01L	14833472	7.14	1.02	101.6
P6 0797-102-1016-32-15 CTN01L	14833473	7.97	1.02	101.6
P6 0714-076-1016-32-15 CTN01L	14833475	7.14	0.76	101.6
P6 0714-089-1016-32-15 CTN01L	14833476	7.14	0.89	101.6
P6 0900-102-0762-40-15M CTN01L	14833477	9.00	1.02	76.2
P6 0635-102-1016-32-15 CTN01L	14833479	6.35	1.02	101.6

* The tool life varies according to the operational and working conditions of the customer requirements, for example with regards to the material to be cut, the wall thickness, the mounting of the nozzle, the throughput, etc.

HyproJET S3



The **S3** continues the success story of the well-known Standard waterjet nozzles. The long tool life* guarantees you highly efficient cutting processes. The all-rounder nozzle has proved its worth in standard applications as well as in demanding industrial contexts.

The S3 stands for excellent quality in many applications with constant cutting performance in all materials and geometries.

Technical specifications

- ▲ Grade UMG01
- ▲ All surfaces ground
- ▲ Wire-eroded internal diameter

Extract from our product portfolio (additional dimensions upon request)

Type, description	Material	D mm	d mm	L mm
S3 0600-120-0700-32-15 UMG01	14833019	6.00	1.20	70.0
S3 0635-076-0762-32-15 UMG01	14833035	6.35	0.76	76.2
S3 0635-091-0762-32-15 UMG01	14833039	6.35	0.91	76.2
S3 0600-102-0700-32-15 UMG01	14833041	6.00	1.02	70.0
S3 0600-102-0762-32-15 UMG01	14833064	6.00	1.02	76.2
S3 0714-076-0762-32-15 UMG01	14833065	7.14	0.76	76.2
S3 0714-091-0762-32-15 UMG01	14833067	7.14	0.91	76.2
S3 0714-102-0762-32-15 UMG01	14833069	7.14	1.02	76.2
S3 0714-102-1016-32-15 UMG01	14833071	7.14	1.02	101.6
S3 0762-102-0762-32-15 UMG01	14833072	7.62	1.02	76.2
S3 0797-076-1016-32-15 UMG01	14833075	7.97	0.76	101.6
S3 0812-091-0762-32-15 UMG01	14833076	8.12	0.91	76.2
S3 0812-102-0762-32-15 UMG01	14833077	8.12	1.02	76.2
S3 0900-076-0762-40-15M UMG01	14833078	9.00	0.76	76.2
S3 0943-076-0762-32-15 UMG01	14833079	9.43	0.76	76.2
S3 0943-102-0762-32-15 UMG01	14833080	9.43	1.02	76.2
S3 0943-109-0790-32-15 UMG01	14833081	9.43	1.09	79.0
S3 0600-076-0700-32-15 UMG01	14833082	6.00	0.76	70.0
S3 0635-102-0762-32-15 UMG01	14833084	6.35	1.02	76.2
S3 0670-102-0700-32-15 UMG01	14833085	6.70	1.02	70.0
S3 0714-076-1016-32-15 UMG01	14833086	7.14	0.76	101.6
S3 0714-089-0762-32-15 UMG01	14833087	7.14	0.89	76.2
S3 0635-050-0508-32-15 UMG01	14833089	6.35	0.50	50.8
S3 0943-076-0790-32-15 UMG01	14833091	9.43	0.76	79
S3 0714-102-1016-32-15R UMG01	14833092	7.14	1.02	101.6
S3 0714-089-1016-32-15 UMG01	14833097	7.14	0.89	101.6

* The tool life varies according to the operational and working conditions of the customer requirements, for example with regards to the material to be cut, the wall thickness, the mounting of the nozzle, the throughput, etc.

Waterjet nozzles

Troubleshooting guide

1. Water orifice misalignment

The water orifice situated prior to the waterjet nozzle plays a big role in the wear properties of the waterjet nozzle and its cutting efficiency. The water orifice and waterjet nozzle positioning are critical since just a few millimetres or a slight angular misalignment, even if not noticeable, can be fatal for the waterjet nozzle.

Water orifices are generally made of sapphire or diamond. Sapphire orifices have the disadvantage of chipping faster than diamond ones, which can easily lead to cracking issues.

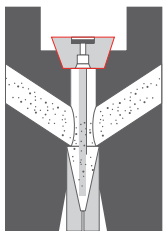

The different water orifice misalignment possibilities

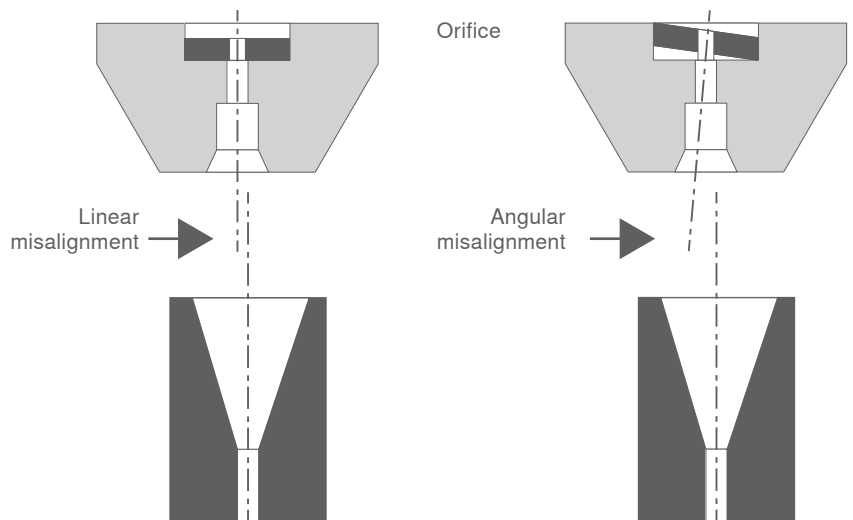

Three scenarios can occur when the water orifice is misaligned or badly mounted.

Serious misalignment

Moderate misalignment

Slight misalignment

Correctly concentric

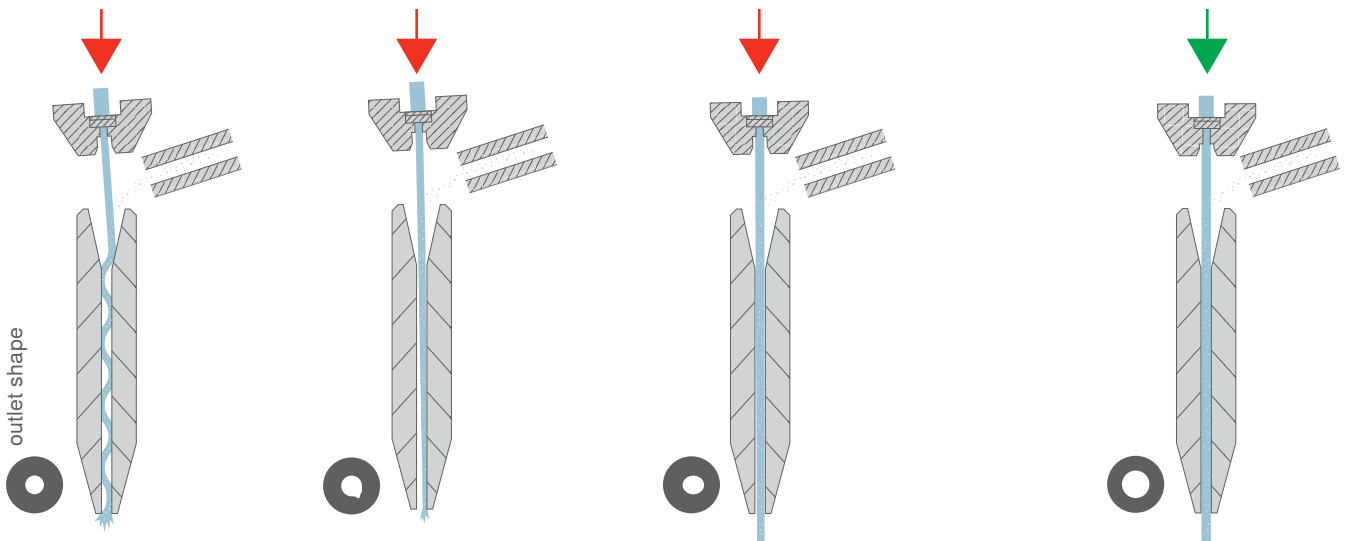

Examples of water orifice misalignment

Schematic view of a correctly concentric water orifice

Any of these misalignment issues can accelerate wear of the waterjet nozzle and reduce cutting efficiency as well as the nozzle lifetime.

It is sometimes hard to detect directly, but some signs indicate something is wrong:

- ▲ Loud or unusual noise during cutting operations
- ▲ Early spraying of the waterjet outside the nozzle
- ▲ Erratic, inconsistent or weak stream exiting from the nozzle
- ▲ Waterjet nozzle bursts during operation
- ▲ Waterjet does not emerge from the channel but exits the nozzle wall at a random location (wall perforation)

The consequences of this issue are generally visible if the nozzle is cut in half. The wear patterns in the nozzle will be asymmetrical and chaotic. This is due to the multiple rebounds of the waterjet inside the nozzle.

The jet penetrates at one point in the channel and is unable to go forward correctly. Generally, the last centimetre of the waterjet nozzle channel is intact; this is why the outlet diameter does not grow very fast.



Completely worn channel as a result of severe misalignment.
On the outside the nozzle is intact since the waterjet was stopped inside the nozzle.

Moderate misalignment of the water orifice / waterjet nozzle

This issue can easily be observed by examining the way the outlet hole grows. The exit diameter becomes oval rather than forming a wider circle, so it looks like a tear drop. The waterjet is not aligned centrally but creates a new path inside the nozzle, which does not follow the focusing channel.

This effect is generally observable after more than 10–20 hours of use.

In this case, the stream of water and abrasive materials cannot run through the tube smoothly and hit the exit hole, damaging the waterjet nozzles and reducing cutting efficiency dramatically.

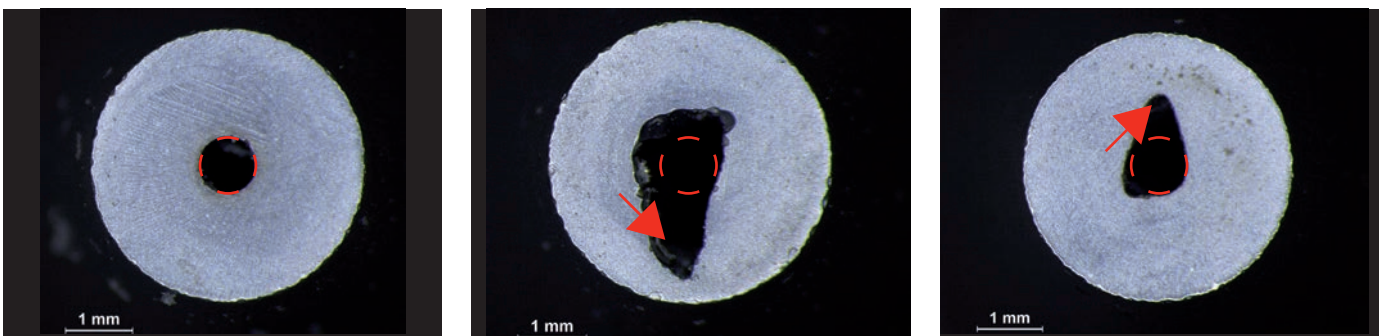

Different examples of observable waterjet misalignment issues. Red circle shows the normal nozzle output diameter, red arrows show the direction of the misalignment.

2. Water orifice wear

The water orifices are generally made of sapphire, ruby or diamond.

Diamond orifices exhibit longer lifetime, greater reliability and lower operating costs per hour than sapphire orifices. Sapphire orifices can be prone to chipping, which leads to impaired cutting quality and reduces the waterjet nozzle lifetime. Other factors affecting the water orifice lifetime are:

- ▲ Dirt or abrasives can plug the water orifice and cause jet spraying or fast chipping of the bore edges.
- ▲ A cracked jewel leads to waterjet deviation or spraying, decreasing the lifetime of both the waterjet nozzle and the mixing chamber.

Sapphire orifices need to be inspected frequently for signs of chipping, cracks and unusual wear, to prevent premature waterjet nozzle deterioration.

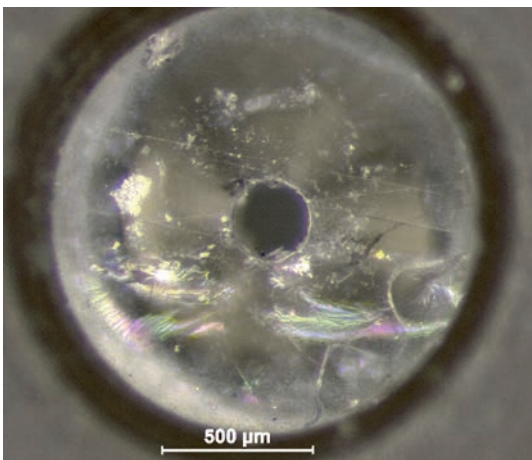

Chipped orifice: cracks and brittle fractures

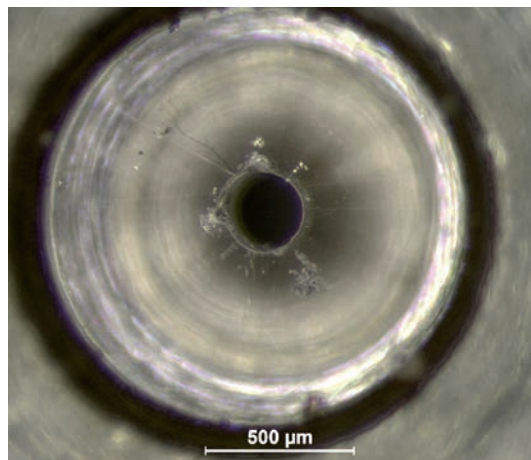

Cracked diamond orifice: multiple fracture and cracks emanating from the orifice

3. Mixing chamber issues

The mixing chamber is the point where abrasive particles and the waterjet meet. The stream of abrasives must stay coherent inside the mixing chamber in order to ensure correct abrasive feed and waterjet concentricity inside the waterjet nozzle. Worn mixing chambers can disrupt all the dynamic flows inside the mixing chamber and affect the abrasive and water stream trajectories. This will reduce the cutting efficiency as well as the tube's lifetime.

Mixing chambers made of steel wear out very fast compared to ones made of cemented carbide. Uncontrolled mixing chamber wear leads to abrasive dispersion outside the waterjet nozzle, reducing cutting power and exacerbating nozzle wear.



Completely worn steel mixing chamber (left) after 40 hours of use and slightly worn cemented carbide mixing chamber after 380 hours (right).

4. Issues with abrasives and plugging

There can be various root causes:

- ▲ Water orifice prior to the WJN is plugged as a result of air suction occurring when re-starting the system after a break.
- ▲ Excessive abrasive accumulation due to incorrect abrasive flux. The mix of high-pressure water and sand creates a kind of 'cement' which plugs the nozzle (dry sand compaction).
- ▲ Unsuitable abrasive grain size; if the grains are too big, the abrasives clog together and plug the channel.

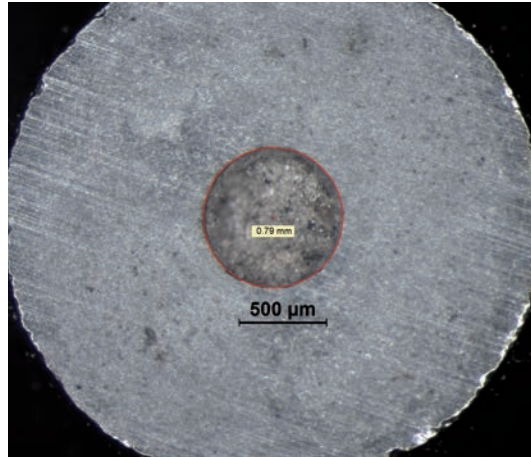
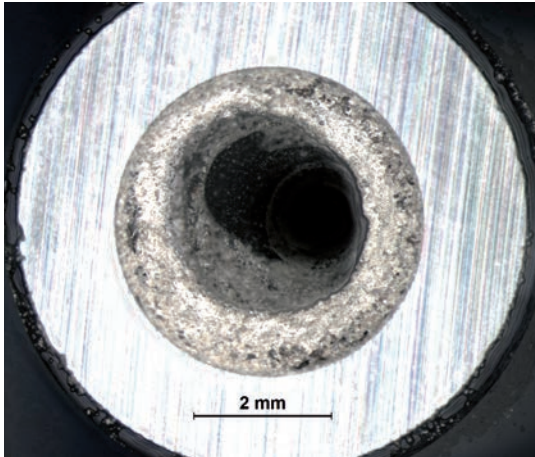

Nozzles plugged with compacted sand (no more water emerging from the nozzle)

5. Correct handling

WJN materials are very hard but also very brittle. Cautious handling is called for, as an impact shock causes microcracks to develop even if they are not visible to the eye. Impacts on nozzle tips are critical as the tip could explode during cutting operations due to weakened microstructure.

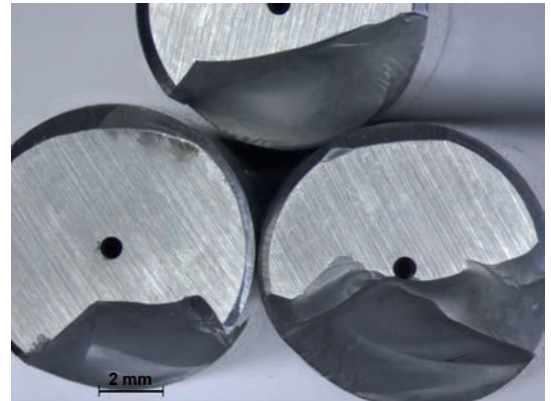

Impacts on nozzle tips or dropped nozzles are fatal.

Easy solutions to prevent WJN wear:

Various solutions can prevent the misuse of waterjet nozzles and help to extend the tool's life:

- ▲ Check the water orifice for chipping, cracks, orifice deformation, presence of dirt
- ▲ Check the water orifice and waterjet nozzle mounting (alignment, orientation)
- ▲ Periodically rotating the waterjet nozzle through 120° can improve the concentricity of the wear pattern and increase lifetime
- ▲ Observe the jet pattern emerging from the nozzle. If it begins to spray more widely there are strong chances of misalignment issues prior to the waterjet.

Good tube wear will be concentric and consistent along the channel. The longer the waterjet nozzle, the more difficult the alignment will be, especially for small inner diameters like 0.76 mm or below.

E-Techstore

Conveniently shop online all around the clock.

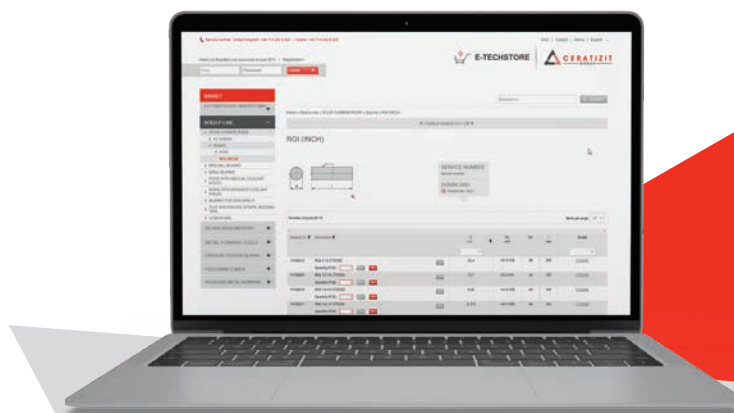

Your advantages



Availability

Shop our large assortment of over 25,000 products online. You will get instant information about availability and real-time stock updates from our warehouses all over the world.



Support

You won't be left on your own. Our customer service and sales teams are always here to answer your questions before, during and after your purchase. All details of your personal contact at CERATIZIT are just one click away.



Our online shop is available 24/7 for you!



Configurator

If you are looking for a customer-specific piece that you can't find in the standard range, our online product configurator makes it easy to design a broad variety of tools and components to meet your needs.



Documentation

Find all your on- and offline transactions in one place (quotations, orders, invoices etc.) with tracking and tracing of your shipment history.



Information

Get detailed information about our products, including CAD data, technical drawings and images, with filters for an easy product search.



User management

Benefit from a multi-user system where you can decide which level of authorisation a user should have, depending on the role within your company.

Hard Material Solutions

Hard cases are our speciality

We are your ideal partner when it comes to high-quality hard materials for production processes, tool manufacturing and wear protection.

From standard products to tailor-made solutions, from massive components to minute parts, from the blank to the fully finished product – a product that meets the highest standards of precision, surface treatment, and user-friendly assembly – our carbide solutions ensure improved efficiency and outstanding total cost of ownership. This is the case in a variety of application fields and industrial sectors. Even when subjected to extreme stress, our cemented carbides are notable for the high flexibility they offer in numerous industries. Our products are specially designed for extreme working conditions, making our Hard Material Solutions impressive tools for optimising your processes and increasing wear resistance.

Product portfolio

- ▲ Blanks and semi-finished products
- ▲ Hot rolls made of cemented carbide
- ▲ Drawing tools & drawing nibs
- ▲ Blanks for rotary cutters
- ▲ Silicon nitride

Solutions for:

- ▲ Tool & die industry
- ▲ Waterjet cutting
- ▲ Hob milling
- ▲ Fastening industry

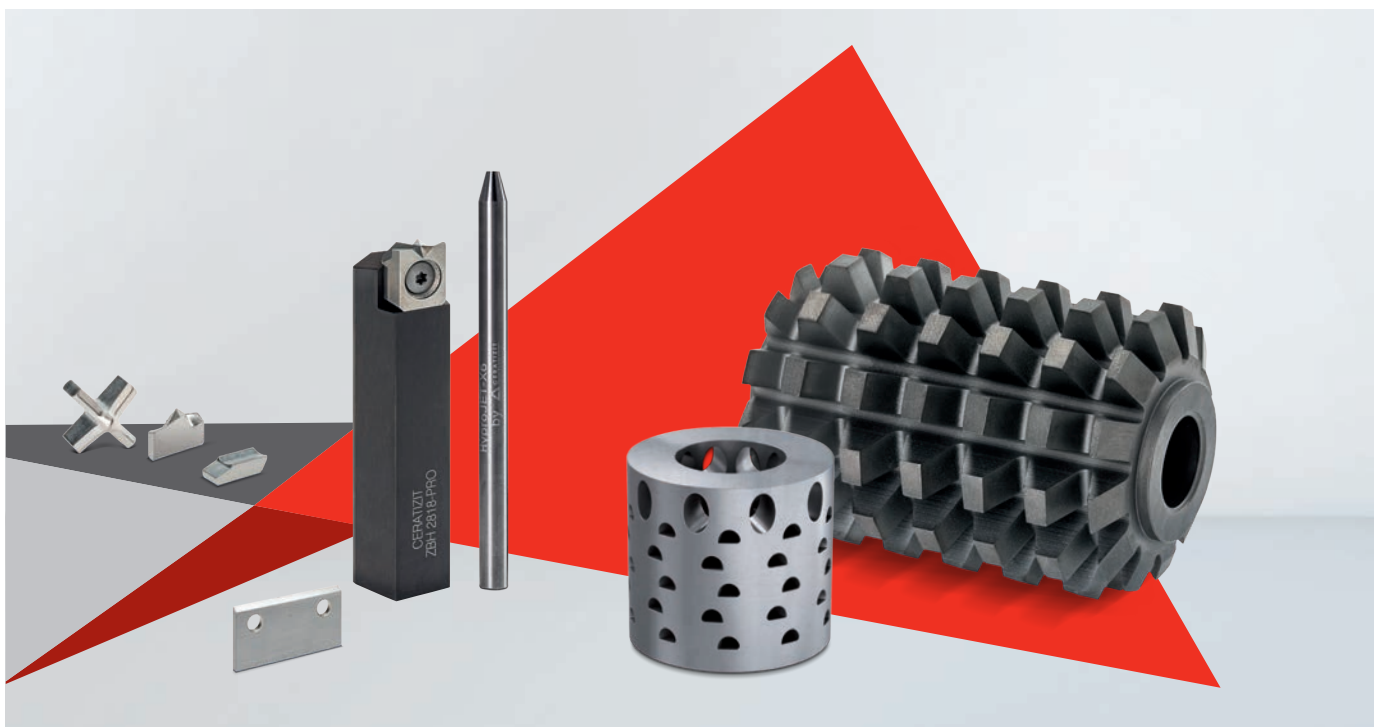

CERATIZIT Group

For over 100 years, CERATIZIT has been a pioneer in developing exceptional hard material solutions for cutting tools and wear protection. The private company, with registered offices in Mamer, Luxembourg, develops and produces highly specialised cutting tools, indexable inserts, rods made from hard materials and wear parts.

The CERATIZIT Group is the global market leader in various application segments and successfully develops new carbide, cermet grades which are used for instance in the wood, metal and stone working industries.

Facts & figures

 **Headquarters**
Mamer, Luxembourg

 **30** more than
production sites

 **8 000** more than
employees

 **80** more than
countries in which we are active

 **1 00 000** more than
products

 **1 000** more than
patents & utility models

 **2 00** more than
R&D employees

 **35** % of products
developed in the last 5 years

 **20** more than
innovation awards

Headquarters

CERATIZIT S.A.
LU-8232 Mamer
T. +352 31 20 85-1
ceratizit.com

Sales site

CERATIZIT Hard Material Solutions S.à r.l.
LU-8232 Mamer
T. +352 31 20 85-1
E. hardmaterialsolutions@ceratizit.com

