

DYNATECT™

DYNAMIC EQUIPMENT PROTECTION

Global Leaders in Dynamic Protection
for Equipment and People

CONDENSED PRODUCT CATALOG 2015

PROTECTIVE
COVERS

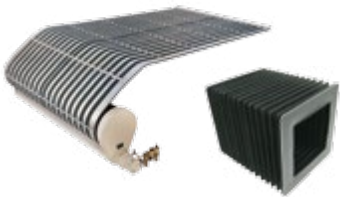

GORTITE®

CABLE AND HOSE
CARRIERS



GORTRAC® & NYLATRAC®

MECHANICAL MOTION
CONTROL PRODUCTS



POLYCLUTCH® & LSI

ELASTOMER
PRODUCTS

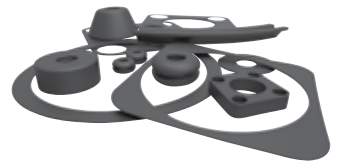

RO-LAB



- 1** Global Headquarters & Manufacturing, Gortite Division
NEW BERLIN, WISCONSIN, U.S.A.
- 2** U.S.A. Manufacturing, Gortrac Division
VALPARAISO, INDIANA, U.S.A.
- 3** U.S.A. Manufacturing, Polyclutch Division
NORTH HAVEN, CONNECTICUT, U.S.A.
- 4** U.S.A. Manufacturing, LSI Division
TRAVERSE CITY, MICHIGAN, U.S.A.
- 5** U.S.A. Manufacturing, Ro-Lab Division
TRACY, CALIFORNIA, U.S.A.
- 6** Europe Sales & Distribution, Halltech GmbH
SCHWAIG, GERMANY
- 7** Europe Manufacturing, MFB Technik
BIELEFELD, GERMANY
- 8** Asia Sales & Support
SHANGHAI, CHINA

FIND WHAT WORKS FOR YOU

As you browse through this catalog, you will get a sense of one reason why Dynatect is the largest manufacturer of industrial equipment protection in the United States. Here you will find everything from protective way covers and bellows to precision ball screws, cable and hose carriers, and custom elastomer products.

With a library of over 500,000 designs, most people would call that a great range.

We call it an excellent starting point.

At Dynatect, we appreciate that unique applications demand unique protection solutions. While 95% of new requests can be met through modification or combination of our existing designs, we're always ready to innovate. The designs you see here represent just the tip of the iceberg. Dynatect has created numerous customized solutions for a perfect fit. We're talking over 500,000.

So never think that you're asking too much from us when you need a tailor-made design. Ask away.

Our engineers and application specialists are keen listeners, and they understand that knowing all the ins and outs of your situation is key to coming up with the perfect solution. You can expect us to pay special attention to every detail. And since all our designs are products of comprehensive vertical integration, you can count on the final result being as solid as the original idea. That is why more than 98% of new Dynatect designs meet application standards on the very first production piece.

This method is as successful today as it was when Dynatect was founded 65 years ago. It's the way of the born engineer: exact, timely and dependable.

Just right.

TABLE OF CONTENTS

PROTECTIVE COVERS – GORTITE®

Protective cover products to protect your equipment and personnel, such as bellows, way covers, steel covers, way wipers, roll up covers and doors.

Bellows and Lift Covers | Pages 4-8

Roll-Up Covers and Doors | Pages 9-11

Steel Covers and Wipers | Pages 12-16

Repair Services | Page 13

Special Products | Page 17

Cable Carrier Overview | Pages 18-19

Design Guide | Pages 22-23

Options & Accessories | Pages 24-27



CABLE AND HOSE CARRIERS – GORTRAC® & NYLATRAC®

We offer plastic, metal and hybrid carriers to satisfy the broadest range of applications – from high-strength nylon carriers to modular open- and enclosed-style designs, and standard open-style designs.

Plastic Brands | Pages 28-37

– Nylatrac Standard

– Nylatrac Modular

– Nylatube® Standard

Metal Brands | Pages 38-43

– Gortrac Steel

– Gortube® Steel



MECHANICAL MOTION CONTROL PRODUCTS – LSI & POLYCLUTCH®

Mechanical motion control applications such as Polyclutch brand continuous friction slip clutches and LSI brand precision ground ball screws.

LSI Precision Ground Ball Screws | Pages 44-45

Polyclutch Precision Slip Clutches | Pages 46-49



ELASTOMER PRODUCTS – RO-LAB

Custom molded rubber and urethane components and applications: insert molding, custom material formulation, precise tolerances and special finishes, and exceptional sizes and thicknesses.

Rubber and Polyurethane | Pages 50-51

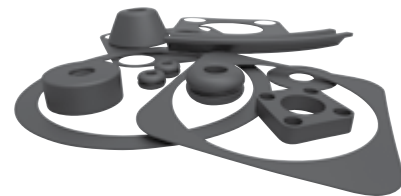

REQUEST FOR QUOTE – IT'S EASY ONLINE

Whether you have a straightforward order, want to modify an existing design or need an entirely new solution, Dynatect makes online quoting simple and easy.

VISIT US AT DYNATECT.COM/RFQ

Have questions? Our technical advisors can answer any questions or offer new ideas – call 800-298-2066.



APPLICATION EXAMPLES



Light-tight folded Gortite[®] bellows used on a photo enlarger, folded construction.

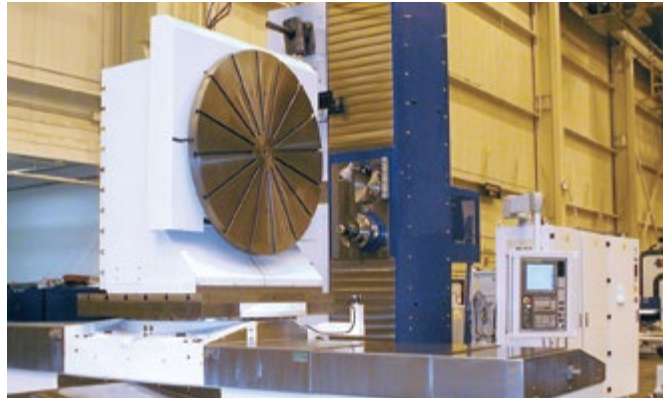

Telaflex[®] steel covers and Gordillo[™] bellows protect the machine ways of horizontal boring machines from accumulating chips and liquids.

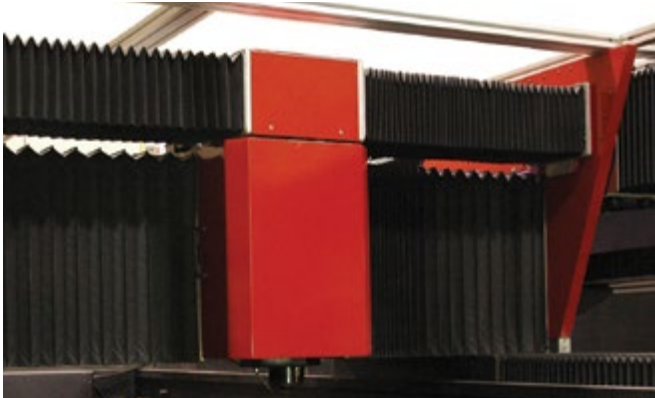

Special laser beam bellows used in horizontal and vertical configurations on a laser.



Gortite bellows and Nylatrac[®] cable carriers on a waterjet machine.



Gortite way covers and Nylatrac cable carriers on a large vertical machining center.



Gordillo bellows covers for machine way protection. Gordillo covers have been successfully applied in vertical, horizontal and crossrail configurations.

APPLICATION EXAMPLES

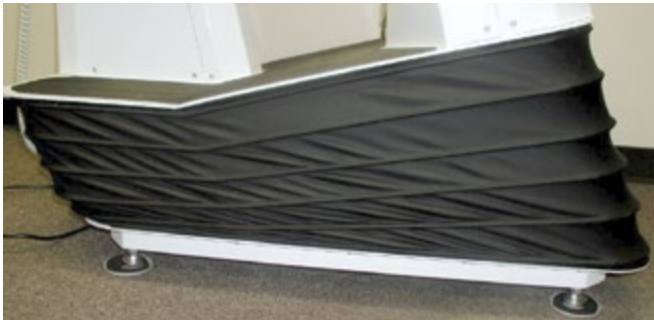

An enclosed Gorframe® cover conceals the operational mechanism while withstanding a range of motion in a variety of directions.

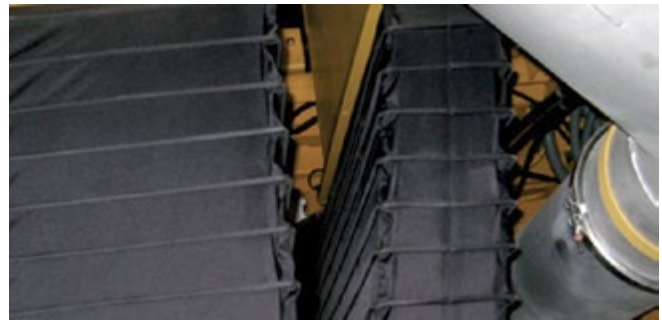

A Gorframe bellows provides flexible ducting on a large mining truck.



Suitable for operation in rugged, outdoor environments, Gortiflex® bellows have been applied on military, commercial vehicles, aircraft and more. They are constructed of elastomer materials rated to withstand UV light, temperature variations and moisture.



Steelflex® walk-on duty covers have been used for decades for personnel safety and machine protection, in the covering of machine ways and inspection pits.



Heavy-duty roll-ups can be applied to fire truck hose beds as a retractable cover, and a walk-on surface when not in use.



Gortite® aluminum roll-up doors are used on fire and emergency vehicles, work/utility trucks, and other commercial vehicles.

CUSTOM-ENGINEERED BELLOWS

Dynatect's bellows portfolio offers the greatest variety of cover materials and construction methods available anywhere. Your sales representative can give you an unbiased product recommendation for your application. Your custom bellow will include the necessary mounting material, metal work, guides or supports, so that you receive a finished product ready to apply to your machine.

Our database contains over 10,000 protective covers which gives our design team a superior frame of reference to supply the right bellows, quickly and cost-effectively. We can also create custom bellows in virtually any shape.

When designing your bellows, we consider the following factors to optimize your design:

- Space available for cover in retracted positions, as well as cross sectional areas
- Interference points along travel path
- Necessary cover support for long travel and maximum unsupported span
- Type and volume of contaminants
- Fitness for operating purpose: temperature extremes, high-cycle operating, acceleration, environment
- Ventilation for sealed covers

SELECTION GUIDE – BELLOWS BY SHAPE

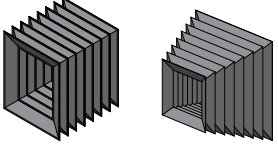
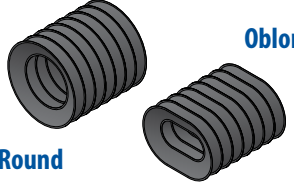
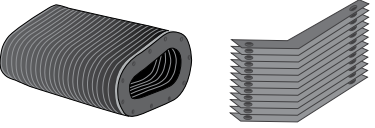
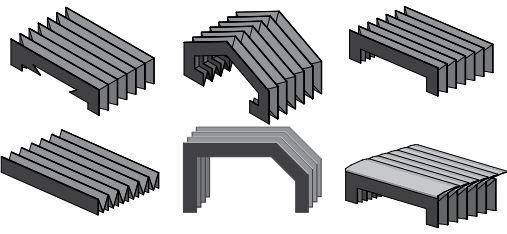
SHAPE/BELLOWS PROFILE	BELLOWS CONSTRUCTIONS Configurable To Shape	TYPICAL APPLICATIONS
 <p>Square, Rectangular, or Tapered</p>	<ul style="list-style-type: none"> • Folded • Gorframe™* • Gortiflex®* • Heal-Sealed • Liftgard™ <p>*Rounded corners</p> <p>Tapered Profile: Folded, Gortiflex, Sewn</p>	<ul style="list-style-type: none"> • Laser bellows • Air intake or exhaust manifolds • Flexible air duct connections • Cameras, imaging equipment • Scissors mechanisms, lift tables • Amusement ride base • Tilt table • Medical table
 <p>Round Oblong/Oval</p>	<ul style="list-style-type: none"> • Gortiflex • Sewn • Thermiseal • Vulca Seal 	<ul style="list-style-type: none"> • Rod boot • Hydraulic cylinder cover • Ball screw cover • Pipe penetration seal • Bellows-type expansion joint • Air intake or exhaust manifolds • Flexible air duct connections
 <p>Non-Standard/Special Shapes</p>	<ul style="list-style-type: none"> • Folded • Gortiflex • Thermiseal • Gorframe • Sewn • Vulca Seal 	<ul style="list-style-type: none"> • Bus and light rail bellows • Robotics • Shift/joystick covers • Seat covers • Screen or aesthetic barrier
 <p>Way Cover (Flat/Strip-Type Screens and Variable Profiles with Legs)</p>	<ul style="list-style-type: none"> • Folded • Sewn-Folded • Gortiflex • Sewn • Gorframe • Vulca Seal • Gordillo™ • Thermiseal • Heat-Sealed <p>Related Products</p> <ul style="list-style-type: none"> • Roll-Up Covers (see page 9) • Gorplate™ Low Profile Stainless Steel Cover (see page 12) • Telaflex® Steel Way Cover (see page 13) 	<ul style="list-style-type: none"> • Machine ways • Linear guide protection • Screen or aesthetic barrier

CUSTOMIZED PROTECTION FOR EVERY APPLICATION



High Temperature Bellows



Heavy Chip Loads



Light-Tight Bellows for Laser Beam Path



Chemical or Coolant Resistant Bellows



Bellows in Abrasive Environments



Bellows for Outdoor and Transportation Environments



Air Duct Bellows



Bellows Exposed to Weld Splatter

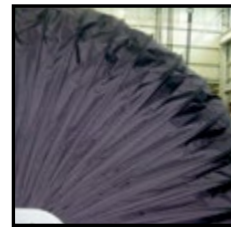

Bellows Operating in Shear/Tilt/Lateral Movements

BELLOWS OPTIONS AND ACCESSORIES



Breather Vents
For breathing in sealed covers.



Grommets
For use with supports or guide rods.

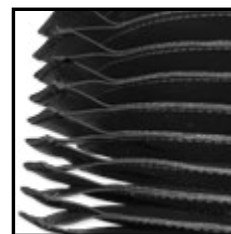

Tie Strips
To limit cover stretch.

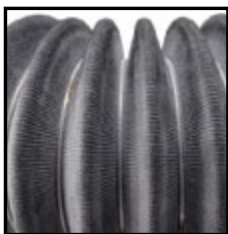

Wire Guides, Internal or External
To maintain shape in sealed covers experiencing internal pressure or vacuum.



Internal Guides (inserts)
For ball screw applications.



Zipper
For easy installation without disassembling machine parts.

BELLOWS & WAY COVERS



No tooling fee for standard shapes

GORTIFLEX[®] MOLDED BELLOWS

Gortiflex bellows are constructed from a tube of elastomer or elastomer-coated fabric formed into a completely sealed cover. With no (or nominal) tooling charges, Gortiflex is perfect for both prototype models and OEM equipment production.

Features/Benefits:

- Excellent extended-to-retracted ratio for a molded cover
- Withstands moderate internal or external pressure
- Sealed construction resists moisture, liquid or chemical spray, contaminants and dirt
- Superior durability in outdoor environments with exposure to moisture, ice, sand, oil, temperature variations and ultraviolet radiation



No tooling fee

SEWN BELLOWS

Sewn bellows are manufactured from heavy-duty elastomer-coated fabric stitched with nylon or specialty thread.

Features/Benefits:

- Low cost protection from dust, dirt and other contaminants
- Flexible process – almost any size and configuration can be sewn
- Widest material selection available
- Economical even in low quantities
- Round, sewn bellows can ship within 1 business day using our expedited ordering system



No tooling fee

HEAT SEALED BELLOWS

Heat sealed bellows are manufactured from a single sheet of thermoplastic-coated fabric, which is pleated and then thermally welded to a PVC stiffener at every fold.

Features/Benefits:

- No stitch holes, seams or breaks
- Uniform cover shape is maintained throughout range of motion
- Stiffener profile can be made to match any way or rail geometry
- Attractive, clean, uniform appearance
- Excellent protection for linear bearings and other precision equipment
- Ideal for applications requiring very large or rigid covers
- Cover retains shape throughout travel



No tooling fee

GORDILLO[™] STAINLESS-STEEL-CLAD BELLOWS

A Gordillo is a sewn-folded or heat sealed way cover made with stainless steel plates covering each convolution. The stainless steel plates shield the bellows from hot chips that quickly damage a conventional bellows.

Features/Benefits:

- Added protection against hot chip loads and weld splatter
- Smaller footprint and extended-to-retracted ratio versus telescoping covers



No tooling fee

SEWN-FOLDED BELLOWS

Sewn-folded bellows are manufactured from a single sheet of thermoplastic-coated or elastomer-coated fabric, which is pleated and then sewn to a PVC stiffener at every fold.

Features/Benefits:

- Cover shape is maintained throughout range of motion
- Stiffener profile can be made to match any way or rail geometry
- Excellent protection for linear bearings and other precision equipment
- Ideal for applications requiring very large or rigid covers
- Diverse material selection – we are able to use thermoset elastomer coated materials that cannot be welded



No tooling fee

FOLDED BELLOWS

Folded covers are constructed out of elastomer or thermoplastic materials. Square or rectangular designs can be tapered, including offset configurations.

Features/Benefits:

- Completely sealed from light, air and dirt penetration
- High durability – can withstand high cycles and high-speed movement
- Withstands moderate internal or external pressure

BELLOWS, WAY COVERS & LIFT COVERS



THERMISEAL BELLOWS

Thermiseal bellows are made from polyurethane films (or polyurethane coated fabrics) bonded together by thermic weld process. The result is a lightweight, completely sealed cover. Tooling charges for new designs may apply.

Features/Benefits:

- Attractive, clean, uniform appearance – great as an aesthetic cover to conceal mechanical components
- Excellent extended to retracted ratio
- Generates minimal airborne particles
- Air, dust and liquid tight
- Can withstand high cycles and high-speed movement
- Lightweight construction and superior extended to retracted ratio is ideal for covering sensitive measuring equipment



No tooling fee

VULCA SEAL® BELLOWS

Vulca Seal is made from separate sections of Goralon® (CSM) joined by vulcanizing alternating seams to form convolutions. Sealed PTFE is available for harsh environments such as chemicals, coolants and high temperatures up to 500° F.

Features/Benefits:

- Extreme durability – long life in abrasive environments
- Withstands moderate internal or external pressure
- Ideal for OEM use on both prototype models and new designs
- Attractive, clean, uniform appearance – no stitch holes, seams or breaks
- Custom designed to match any rail or way profile



MULTIFLEX DIP-MOLDED BELLOWS

Made in Germany

This dip-molding process is suitable for up to 5,000 pieces. Dip-molded bellows are available in almost any geometry and with single or two-color immersion. Black, grey and white PVC plastisol are the most common selections; additional colors are available for high volume production runs.

Operating temperature range is -30° C to +80° C. The bellows can be immersed to create defined hard- and soft areas upon special request.

Features/Benefits:

- Available in almost any geometry
- Neat, clean appearance
- Low cost tooling and low cost per bellows
- Speedy prototype tooling and sample delivery
- Seamless protection against water, oil and other contaminants
- Excellent UV and ozone resistance
- Suitable for special applications such as food grade and clean room



HIGH TEMP ROBUST BELLOWS

Made in Germany

Characterized by a long service life and high tensile strength, we call them robust for a good reason.

Features/Benefits:

- High temperature resistance to up to 900° C radiant heat
- Resistance to acid and basic chemicals
- UV/Ozone resistance
- Extreme durability and tear strength
- Optional PTFE coating to inside or outside of bellows
- Materials: CR-Rubber/Fabric, Aluminized Carbon Fiber, Aluminized Kevlar®, Fiberglass



GORFRAME® WIREFRAME

Gorframe bellows use internal or external wires to maintain the shape of the bellows.

Features/Benefits:

- Designed to withstand a range of motion in a variety of directions, including lateral (shear) movement
- Ideal for concealing operational mechanisms, as a lift/tilt table cover or seat cover
- Small retracted length allows cover to retract into a tight space



*Patent Pending

LIFTGARD™* LIFT TABLE COVER

The Liftgard is constructed of precision engineered aluminum extrusions shaped to provide structure and strength to folded PVC/nylon. The standard design is equipped with vented corners and a zipper (the design can be modified as needed for washdown applications).

Features/Benefits:

- Pre-assembled covers are folded for shipping, then easily unfolded for assembly – this reduces assembly time by eliminating the need to insert steel rods
- Corner venting optimized to accommodate rapidly rising and descending lifts
- Aluminum frame provides a stiffer, more supportive structure than typical steel rod configuration – eliminates rusty metal rods protruding from cover ends

Kevlar® is a registered trademark of E.I. du Pont de Nemours and Co.

TRANSPORTATION BELLOWS

BELLOWS FOR TRACTION MOTOR VENTILATION

This design is specialized for the ventilation of traction motors on electric locomotives and railcars, serving as an integral part of the cooling air flow as a flexible connecting element between traction motor blower and drive motor. Constructed with seamless tubing in silicone-coated Meta-aramid fabric or other materials, wire reinforcements are fitted inside the convolution peaks. Product solutions for OEM and retrofitting have been optimized for European and North American customers.



BELLOWS FOR ARTICULATED BUSES AND LIGHT RAIL VEHICLES

For decades, Dynatect has supplied OEM and replacement units to numerous transit authorities and bus manufacturers throughout North America. Dynatect and ATG Autotechnik GmbH provide complete articulation solutions beyond the main bellows, including articulation joint and center hoop components. Bellows for transportation vehicles are manufactured from a variety of materials including pure elastomers, elastomer coated fabrics, urethane coated fabrics, and PVC coated fabrics. The proper material is selected on the basis of environmental conditions, flame retardant requirements and smoke emission regulations.



CUSTOMIZED PROTECTIVE BELLOWS

Are Also Available For:

- Engine intake/exhaust and HVAC ducting
- Exterior cable protection ducting
- Hydraulic cylinder rod protection
- Steering column cover
- Door hinge cover
- Shift/joystick cover

SHADE ROLLERS | LIGHT-DUTY ROLL-UP COVER

Sometimes a simple shade will do the trick. Shade rollers are ideal for machine guarding applications where there is little room for other protective covers, with the added benefit of easy mounting. Minimal cost and delivery times also make shade rollers a common solution for retrofitting. Suitable for high speeds and accelerations. (For heavier chip loads, consider a medium or heavy duty Steelflex® or Alumaflex cover.)

Basic construction combines a coated or uncoated textile fastened to an industrial spring roller, supplied with mounting brackets or a protective canister. The canister comes with a scraper (or brush) to clean the shade as it retracts. For unsupported horizontal applications, optional side channels are recommended to guide the shade as well as minimize the amount of contamination penetrating the shade. Visit this web link for bracket drawings, material options, and a quote request form to specify your application requirements: Dynatect.com/ShadeRoller

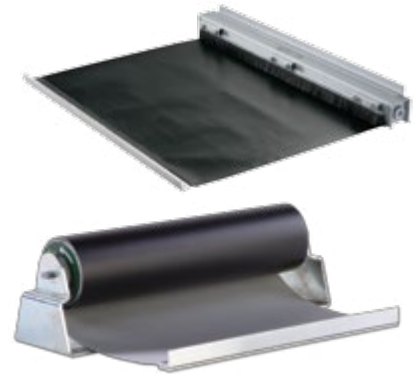

TYPICAL SHADE ROLLER DIMENSIONS

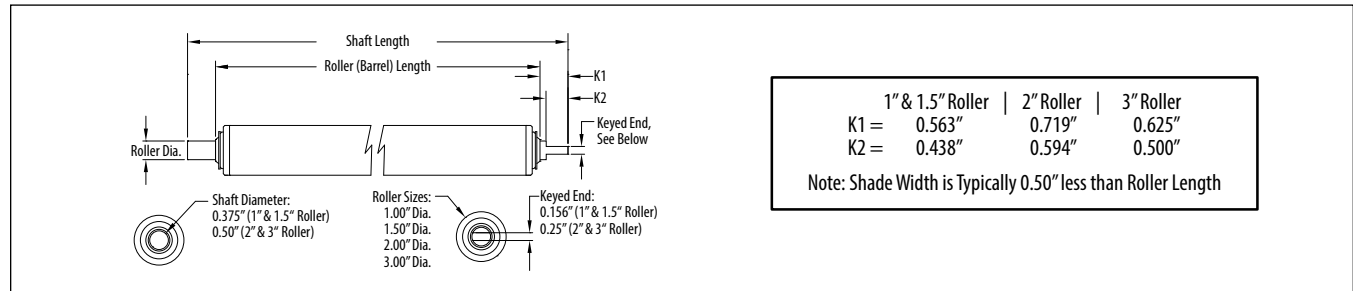

ALUMAFLEX | MEDIUM-DUTY ROLL-UP COVER

When aesthetics are important, Alumaflex shades are the covers of choice for many automated applications such as machine tool changers. Alumaflex can be used as a barrier against medium-duty exposure to coolant and chip loads. Made of interlocking anodized aluminum extrusions and rolled up into a roller barrel or canister. Alumaflex, used as a door, can be integrated into a custom assembly complete with metal housing, a motor and drive controls.

Visit this web link for rib style options and a quote request form to specify your application requirements: Dynatect.com/Alumaflex

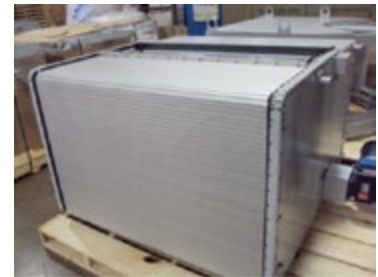

STEEFLEX® | MEDIUM-DUTY ROLL-UP COVER

Steelflex standard-duty roll-up covers provide way protection against moderate hot chip and coolant loads in milling and drilling machines. With low deflection over wide spans, they are an upgrade over fabric shade protection for milling and drilling machines. All widths can be rolled compactly over a spring-loaded roller. Standard-duty Steelflex has a stainless steel top surface with 1/4" x 1/4" aluminum extrusions bonded to the underside for extra strength and support.



Applications/Environments:

- Moderate hot chip or coolant loads
- Higher ambient operating temperatures
- Machine way protection
- Milling/drilling machines

Steelflex Standard-Duty Options:

- Canister housing or mounting brackets
- Sponge edge seal
- Air brake
- Nylon riders
- Brush wiper

Visit this web link for rib style options and a quote request form to specify your application requirements: Dynatect.com/Steelflex

STEELFLEX® WALK-ON ROLL-UP COVERS | HEAVY-DUTY

METAL ROLL-UP COVERS FOR MACHINE WAYS AND PITS

Steelflex “walk-on” style covers are designed for applications for covering machine ways or for covering pits. These covers were primarily used in the machine tool industry but have recently been used to cover inspection pits, machine tool changers, or large chemical tanks. The shade consists of aluminum or steel ribs bonded to stainless steel, and customized with the appropriate options and take-up hardware. Steelflex covers can be rolled up using an air-motor or into a scroll, and can be made to cover openings up to 8 meters wide. These covers can also be supplied in a custom enclosure that can be mounted at the end of the bed way or pit or on a gantry for a large machine.

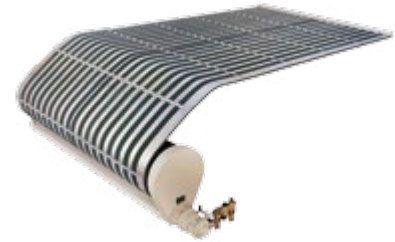

Steelflex Walk-On Covers Are Ideal for Applications Where:

- Exposed ways or pits create a safety-hazard for workers
- Containment of large tanks requires a wide/long span
- Workers may need a walk-on surface to access machinery during maintenance period

Applications/Environments:

- Machine ways or pit cover
- Inspection pit cover or machine tool changer pit cover
- Roll-up cover for chemical tanks

Steelflex Walk-On Cover Options:

- Spring drive take-up
- Motor-driven scroll take-up
- Filter lubricator regulator
- Air brake
- Nylon riders
- Brush wiper
- Non-skid tape or paint
- Sponge sealed edges



Non-Skid Paint

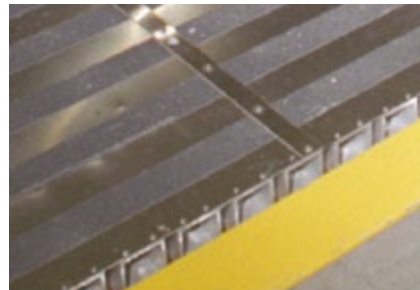

Non-Skid Tape



Sponge Sealed Edges

Sponge sealed edges provided added protection of ball screws and precision scales mounted below the cover by preventing wicking of coolant along the bottom of the cover surface.

TANK COVERS, MOTORIZED MACHINE CURTAINS AND DOORS

MOTORIZED CURTAINS, DOORS AND SHADES FOR MACHINES

Motorized machine curtains offer a custom-engineered frame and drive unit requiring no limit switches. The maintenance-free, gearless direct-drive motor can be programmed for acceleration, partial opening and closing, and speeds up to two meters per second via provided software. Curtain materials are application-based, such as welding screens, aluminum slats, or metallic roll up shade.

Applications in Automated Equipment Cells and Machining Centers

Motorized curtains are ideal for robotic welding areas, operator protection, and other automated equipment cells. Metallic doors for machining centers are also available. Manually operated or motor-driven metallic roll up curtains are suitable for easy access and attractive styling on a metal cutting laser machine tool or for other industrial enclosures.



MOTOR-DRIVEN OR MANUALLY-OPERATED TANK COVERS

Roll-up tank covers are ideal for covering large tanks and can be equipped with a motor drive featuring full electric control for forward, reverse and stop functions. Dynatect has the resources to design and deliver a complete system in any width or length you require. A scroll-type take-up mechanism is also available. Shades are usually constructed of continuous stainless steel top surface with aluminum or stainless steel support ribs for large

tanks. When environmental conditions prohibit the use of steel, thermoplastic designs are available.

Applications:

- Chemical, degreasing, plating, and painting tanks
- Containment of hazardous fumes
- Control evaporative emissions
- Prevent contamination in tank
- Protect personnel



Quote Request:

1. Please send a sketch, drawing or model of your application along with a description, listing details such as the type of tank, contents of tank, etc. Please note if the application requires dual (opposing) covers at each end, or a single cover mounted to one end.
2. Specify drive system: Motor-driven or manual.
3. Provide inner and outer tank dimensions, noting largest unsupported span and tank depth.

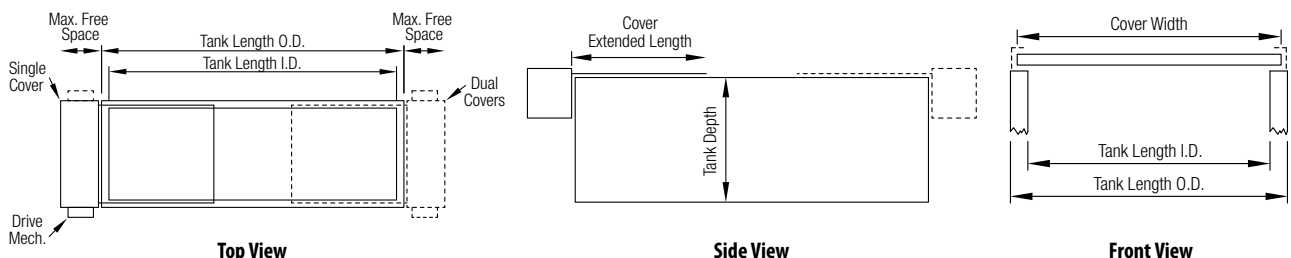

GORPLATE™ | STEEL COVERS

Ideally suited for protection from hot chips and weld splatter, Gorplate stainless steel protective covers provide an additional level of protection not available using conventional fabric bellows. This innovative system of stainless steel plates and monofilament connections creates a lightweight cost-effective system to protect linear rails, ways and machine elements from damage.

The unidirectional monofilament plate connection provides uniform plate expansion in a low profile design. Overall cover depth is approximately 1 inch with the capability of manufacturing cover widths as narrow as 7 inches.

These covers have performed to one million cycles at up to 2G's to ensure that they meet your high speed and high cycle requirements.

Features/Benefits:

- Alternative to sliding plate systems that are prone to locking
- Non-corrosive stainless steel
- Low profile
- Light weight
- Mild steel side rails and end plates included (stainless steel option available)
- Resists heavy chip load
- Resists weld splatter
- Excellent extended to retracted ratios
- Quiet operation



TELAFLEX® | STEEL COVERS

CUSTOM DESIGNED

Telaflex telescopic covers are custom-designed for any machine application requiring protection of machine ways and screws. With a Telaflex way cover, your valuable equipment will be protected from hot or heavy chip loads, dirt, oil, coolants, and from accidental damage caused by dropped tools and work pieces.

Features:

- Top section tread plate or tool tray available
- Section material 18 ga. through 1/4" cold rolled steel (stainless steel option available)
- Way extensions can be provided if necessary
- Standard oiled finished (bright buffed option available)

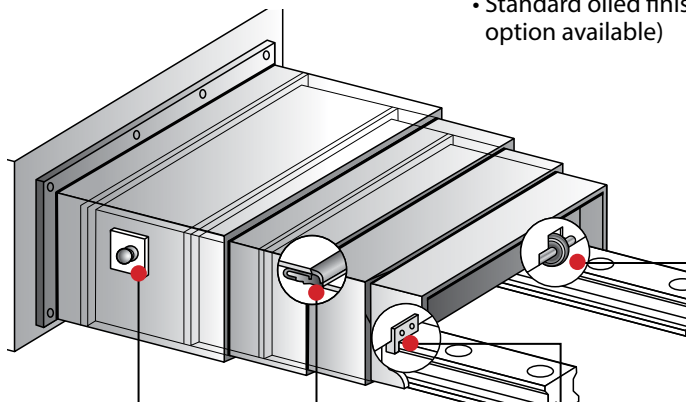

Lifting Lugs Provided on Large Covers

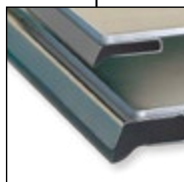

Heavy-Duty Wipers



Nylatron or Brass Guides



Bearing Rollers



TELAFLEX® WAY COVER REPAIR SERVICE

FOR ALL TYPES OF DAMAGED METAL TELESCOPIC WAY COVERS

Replacing metal way covers can be costly and is often unnecessary. Dynatect can repair your damaged cover to OEM specs or better, faster than you can replace them with new – at a fraction of the cost.

- Complete repair, reverse engineering, design and fabrication services available
- Prompt, accurate quotations
- Expert analysis and diagnosis of chronic failures
- Technicians with over 20 years production and repair experience
- All covers are tested before shipment
- Expedited service available for most repairs
- Large inventory of replacement parts



LSI SCREW REPAIR SERVICE

IS YOUR BALL SCREW LOSING ACCURACY?

Contact us for a free repair/replace analysis of your precision ball screw assembly.

NEED TO GET BACK UP AND RUNNING IN A HURRY?

We can reload your screw in 24 hours to get you back up and running.

Our expert technicians can repair or rebuild your ball screw, acme screw, lead screw or specialty threads to save you money and extend the life of your old screw before a costly replacement becomes necessary. We repair nearly all brands of screws.

TYPES OF SCREW REPAIR

Level 1 Reload (restored to "like new" condition – 1 year warranty)

- The ball screw assembly cleaned and evaluated
- Visual and physical inspections of the unit are performed to determine if unit is re-loadable
- The unit is reloaded with new balls, tested, and inspected to ensure the unit is repaired to "like-new" operating characteristics
- Particular attention is paid to: smoothness of operation, minimization of backlash, and minimization of dead-band condition
- Bearing journals, locknut threads, or keyways will be repaired upon customer request

Level 2 Reload (temporary repair – no warranty)

- The ball screw assembly cleaned and evaluated
- Visual and physical inspections of the unit are performed to determine if unit is re-loadable
- The unit is reloaded with new balls, tested, and inspected
- "Like-new" characteristics cannot be entirely achieved

Regrind and Ball Nut Replacement (1 year warranty)

If after a thorough evaluation, it is found that the ball screw cannot be reloaded due to pitting, brinelling, and/or damage to interior or exterior of unit, then the unit could be refurbished by manufacturing a new ball nut and regrinding the existing screw to remove pitting and taper.



Go to the "SERVICES" link on our homepage to find instructions for sending in your product.

CUSTOM WAY WIPERS | FABRICATED AND MOLDED PROFILES

CUSTOM MOLDED (POLYURETHANE)

Molded way wipers are made from high-quality polyurethane for exceptional abrasion resistance. Construction is one-piece with metal inserts. They are ideal for moderate to high volumes and OEM applications (a nominal tooling charge required). Metal chip guards are offered for heavy chip load applications. Standard profiles are 1", 3/4", and Low Profile (LP); also available are custom-engineered cross sections to your specifications. Molded urethane way wipers are also available by part number for Okuma and Mori Seiki machines. Wipers include molded-in steel insert plates and pre-drilled mounting holes for fast, easy installation.



STANDARD MOLDED WAY WIPER PROFILES

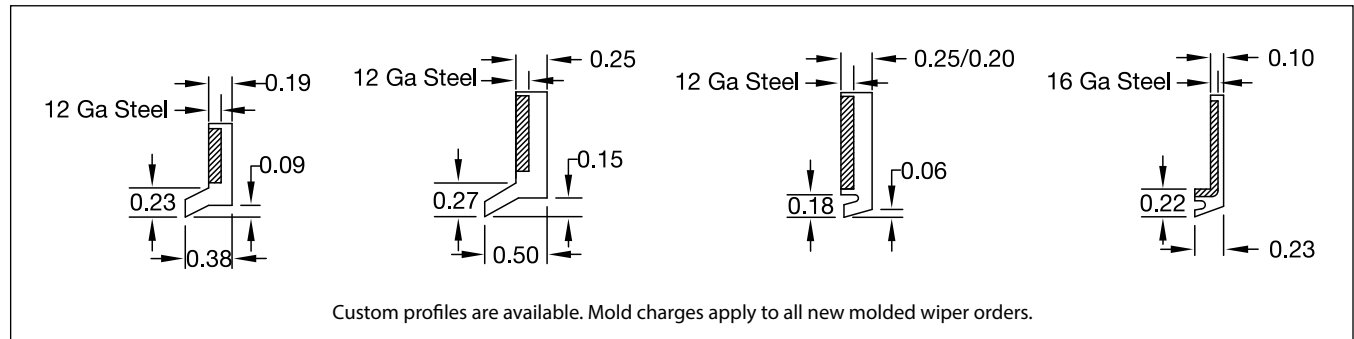

FABRICATED BUNA-N (NITRILE)

Fabricated way wipers are ideal for low to moderate volumes, typically used in maintenance and repair applications. They are fabricated from corners and straight lengths of molded Buna-N rubber – two basic styles are available:

- Type A** – For heavy chip loads and coolants. Fully enclosed in a metal channel with spring-steel chip guard.
- Type B** – Large wiping edge for heavy coolant applications. Both styles supplied with mounting plate for easy installation. If what you need is not shown, Dynatect can make most any shape. Send a drawing of your custom profile or contact us for instructions on sending in your wiper product for quoting.

FABRICATED WAY WIPER PROFILES

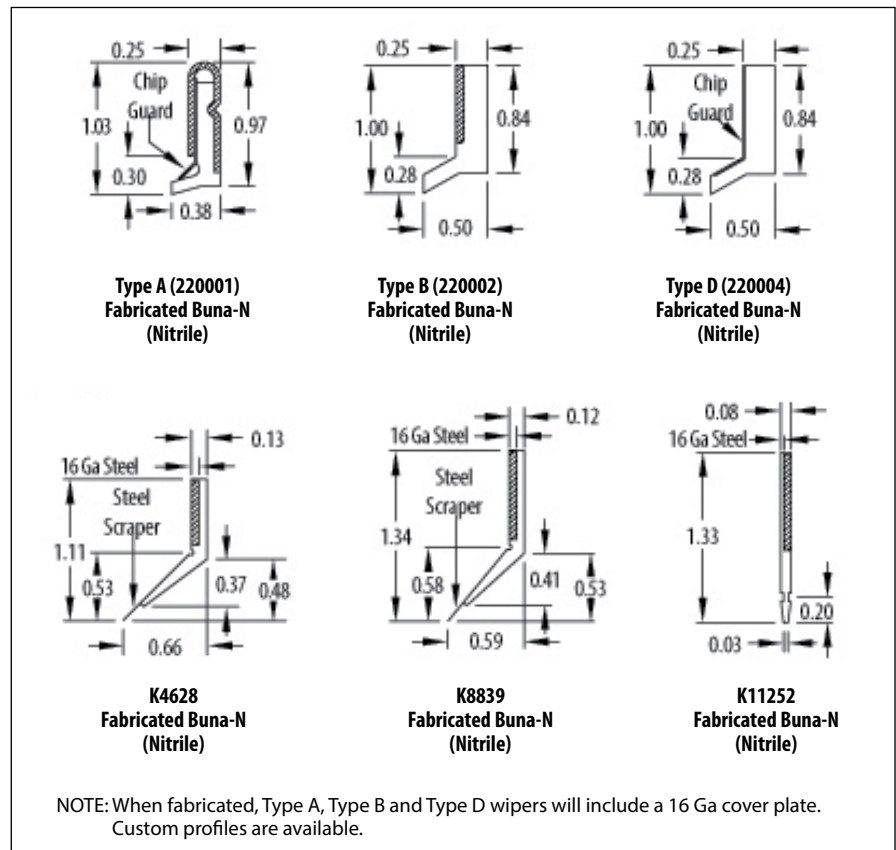

STOCK WAY WIPERS

Gortite® stock wipers save costly maintenance, reduce downtime, and prolong the service life of machine tool ways. They are molded from abrasion and oil-resistant Buna-N elastomer. Four types of molded wipers and two types of steel edged way wipers are available from stock for fast delivery, without tooling charges.

STANDARD MOLDED STOCK WAY WIPERS

All four types employ the same style wiping member and are available in standard 22" lengths, which can be easily cut to required lengths. Oversized holes may be drilled in wiper and screws may be used to attach wiper to sliding member. Use of oversized holes makes it easy to adjust the wiper closer to the way for extended service life.

- **Type A (Part No. 220001)** – Metal enclosed molded wiper with a finger spring to act as a chip guard
- **Type B (Part No. 220002)** – Molded wiper with metal strip bonded to one side
- **Type C (Part No. 220003)** – Molded wiper only. Recommend use of metal mounting plate
- **Type D (Part No. 220004)** – Molded wiper with light metal strip which acts as finger spring and chip guard

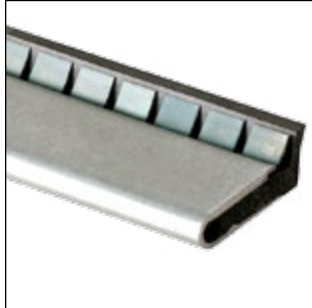

Type A



Type B



Type C



Type D

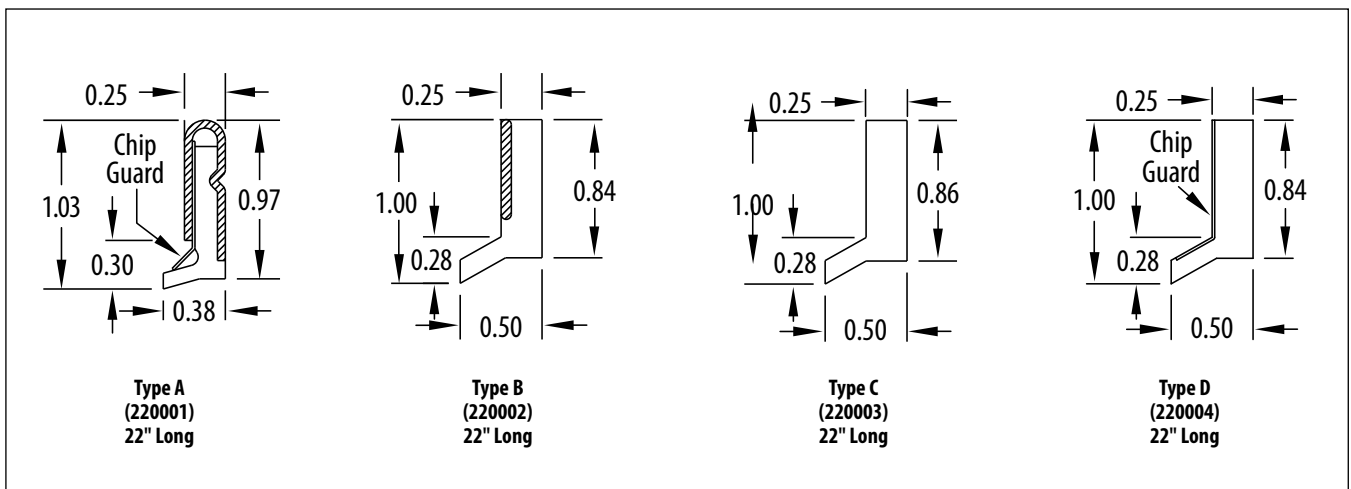

STOCK WAY WIPERS

ADDITIONAL STOCK WIPERS

- Part No. K1505 – 96" Long
- Part No. SK7062 – 3/4" Molded – 30" Long
- Part No. SK7082-30 – Low Profile Molded – 30" Long

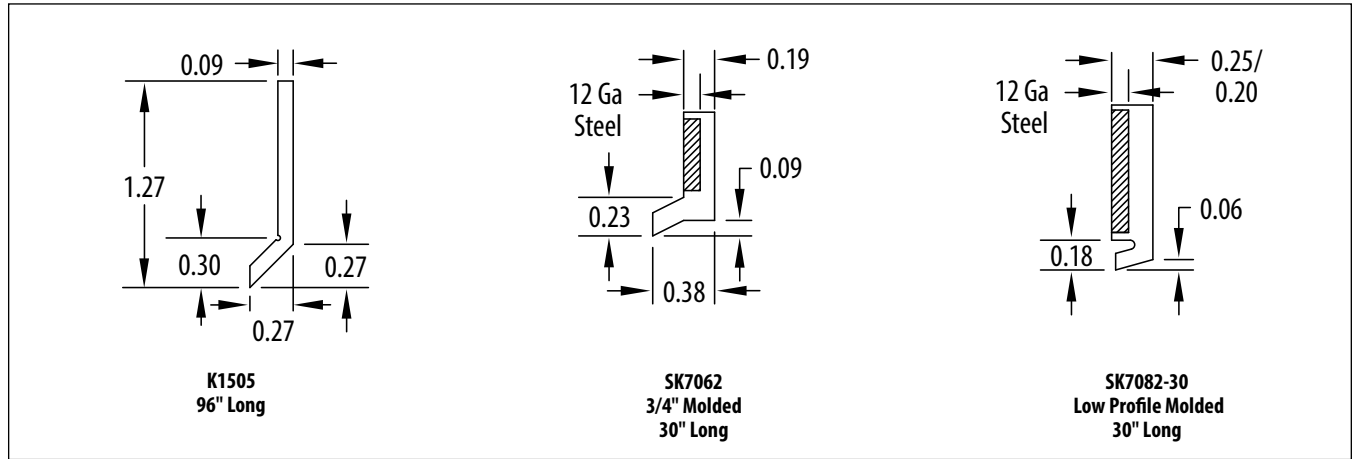

STEEL EDGE KNEE WIPERS

Buna-N (Nitrile) rubber wiper with molded-in steel mounting plate, and a thin spring-steel guard along the length of the wiping edge. A unique wiper for tough applications where the aggressive properties of the spring-steel against the surface being wiped are required along with the flex of the rubber hinge (easily cut to the required length). Oversized holes may be drilled for easy installation and adjustment.

- Part No. K4628 – Available in 27" Lengths
- Part No. K8839 – Available in 31.5" Lengths

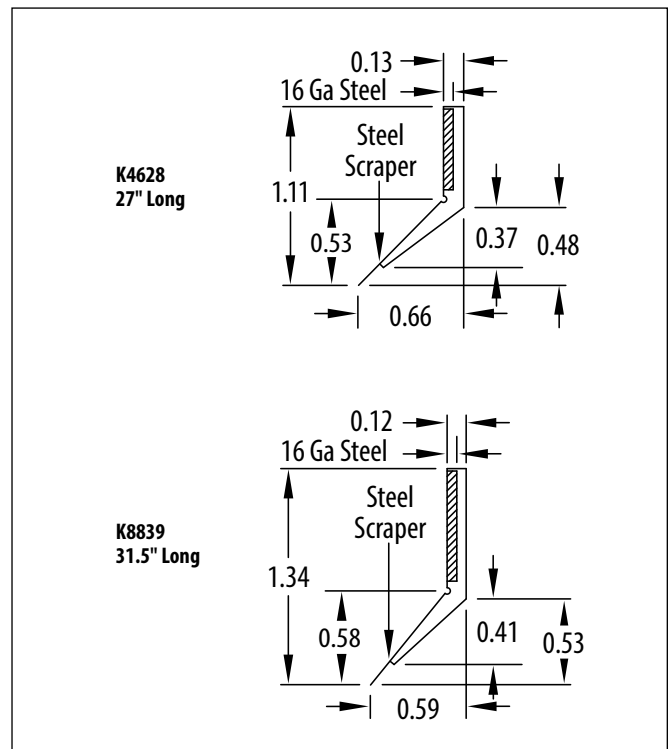

To place an order, call or email us at the number below.
Please note, we will send a quotation for your approval before processing your order.

SPECIAL APPLICATION PRODUCTS



JANUS MACHINE DOOR ACTUATORS

For Automating the Opening and Closing of Protective Machine Hoods

A complete system for implementing a safe force and speed limit on horizontal doors weighing up to 750 kg. Consists of: control system, software, and a compact, maintenance-free and gearless direct drive motor with an integrated position sensor.

MORE INFO AT: DYNATECT.COM/JANUS



GORTITE® WELD CURTAINS

For Protection Against UV Radiation in MIG, TIG and Stick Welding

Convenient weld curtains with high-visibility yellow-painted bases are offered as single, portable curtains, or as modular assemblies design to attach together to provide a work cell.

MORE INFO AT: DYNATECT.COM/WELDCURTAIN

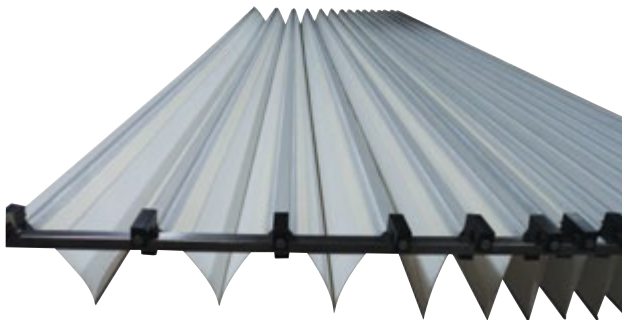

GORTITE MACHINE ROOF COVER

For Containment of Dust and Particles

A translucent bellows cover fastened to a lightweight gliding support system, with a large, self-supporting span and minimal deflection. Cover material: polyurethane TPE with high-strength monofilament polyester.

MORE INFO AT: DYNATECT.COM/ROOFCOVER



GORTITE MULTI-AXIS FACE SHIELDS

Custom Multi-Axis Protection for Machine Tool or Automation Applications

Achieve simultaneous, dynamic protection for each axis of movement with a Gortite face shield. A number of different protection methods can be incorporated: stainless steel shade, elastomer-coated belting on a spring roller, or sliding steel plates. The spindle can use a custom cutout, molded wiper and/or bellows. Multiple roll up covers or protective sliding plates cover the two main axis, while a ram wiper or bellows can be used for a third axis.

MORE INFO AT: DYNATECT.COM/XY-SHIELD

PLASTIC CARRIERS | NYLATRAC® AND NYLATUBE®

Versatile, user-friendly carrier solutions molded from standard glass-filled nylon or special polymers. These carriers are available in a variety of designs and constructions suited for applications ranging from basic to demanding operation. Durable Nylatrac and Nylatube carriers offer excellent corrosion resistance, and reliable operation in applications requiring high speed/acceleration and/or long travel operation.



NYLATRAC STANDARD

- Plastic solution for light- to medium-duty applications featuring clean, lightweight designs for economical cable/hose management
- Open-style links leave cables/hoses open to regular inspection
- Simple “snap-together” link construction allows easy repair and adjustment of length
- Hinged plastic crossbars provide quick cavity access and easy installation
- Standard sizes available from stock



NYLATRAC MODULAR

- Versatile modular design – easily customized from the widest variety of standard components
- Durable construction from separate glass-reinforced nylon sidebands with locking hubs (replaceable bearings) and multiple lockout points (for incredible strength), joined by top and bottom crossbars or lids
- Enclosed-style designs (with snap-in plastic or bolted aluminum lid armor plates) offer additional protection where needed
- Widest variety of crossbars, most available in custom widths and in plastic or aluminum styles



NYLATUBE STANDARD

- Completely enclosed plastic solution for light- to medium-duty applications featuring clean, lightweight designs for economical cable/hose management
- Enclosed-style links protect cables/hoses from dirt and debris
- Simple “snap-together” link construction allows easy repair and adjustment of length
- Hinged plastic lids (KOE and KLE Series) allow quick cavity access and easy installation
- Standard sizes available from stock

METAL CARRIERS | GORTRAC® AND GORTUBE®

Durable alternative to plastic solutions for heavy-duty or unique and challenging applications. Innovative Gortrac carriers provide superior strength-to-weight ratios and maximum unsupported spans. Fully-enclosed Gortube carriers offer the best protection from hot and abrasive elements and liquids, and can operate at faster speeds and accelerations.



GORTRAC STEEL

- Excellent load-bearing and unsupported travel capability (depending on carrier load)
- Longer travels can be achieved with Gortrac Long Travel Support Systems
- Unique, patented link designs reduce parts and simplify construction while providing the strongest carriers, at lighter weights, relative to size
- Manufactured from plated or stainless steel – our zinc dichromate plating process offers 70% better corrosion resistance than standard zinc plating
- Open-style, self-cleaning designs allow dirt and debris to be expelled from the carrier, and leave cables/hoses open to regular inspection
- Enclosed-style designs (with bolted aluminum lid armor plates) protect cables/hoses from heavy abrasive and hot chip loads



GORTUBE STEEL

- Conduit-style galvanized steel tube fully encloses cables/hoses to resist hot chips, swarf, cutting oils and lubricants
- Smooth, low-noise operation; suitable for faster speeds and accelerations
- Construction options for high temperatures, corrosive environments, or multi-axis and rotational applications
- Optional black oxide finish
- Wide range of sizes – 24 different size/radius combinations

PLASTIC CARRIERS | APPLICATION EXAMPLES



Nylatrac® Modular TS and TSC carriers installed on custom pick-and-place equipment provide cable/hose management for long travel and three axis of operation.

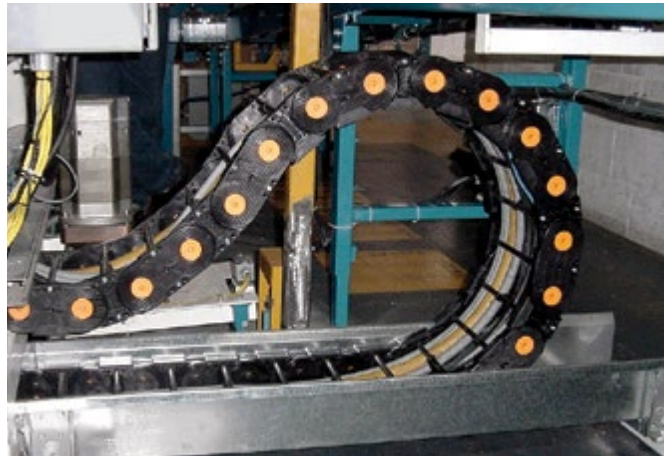

In this low-mount gliding application, decreased tow force is achieved with a Nylatrac Modular TS carrier with low-friction modular sliders. Low mounts are used in carrier designs for increased load/travel capability.



Nylatrac Modular TL carriers designed for long travel on a multi-axis riveting machine. The open-style carrier (lower left) is equipped with aluminum flat bars and low-friction modular sliders in a lowered mounting height configuration. The enclosed-style carrier (upper right) shields cables from ejected rivet heads and debris with heavy-duty bolt-in aluminum armor plates.



Nylatrac Modular TL carriers, with anodized aluminum crossbars for added strength in heavy wind conditions, maintain the lines for electric and hydraulic controls on a vertical lift bridge.

Shown: The Main Street Bridge in Jacksonville, Florida.

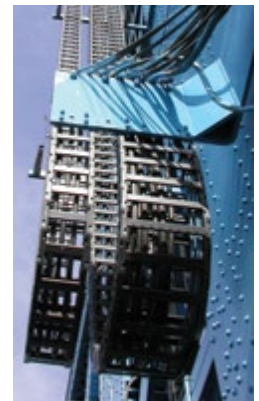

METAL CARRIERS | APPLICATION EXAMPLES



Custom stainless steel Gortrac® LRC carrier system with rolling carriage for a rocket launch system in California. Driven end modified for customer's application requirements.



Gortrac steel SRC carrier with window extenders on underground boring equipment.

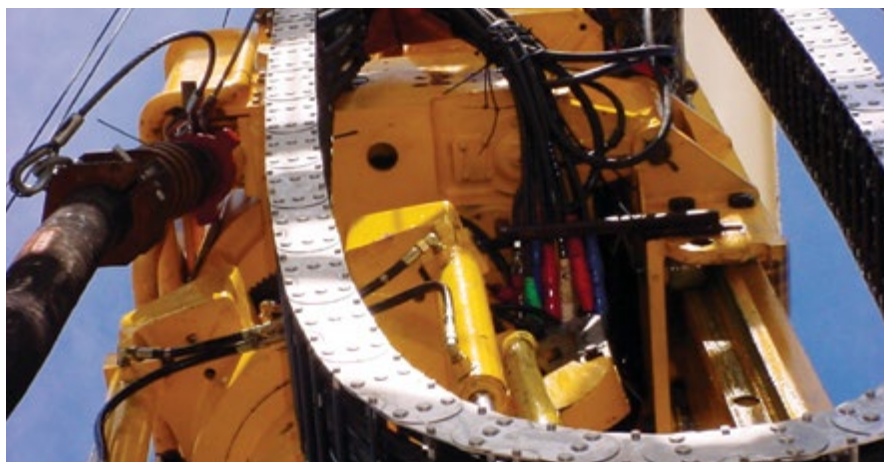

Custom 91-foot long Gortrac stainless steel LRC carrier maintains cables and hoses on an oil rig platform. Dynatect supplies many custom engineered carrier systems to the oil and gas industry.



Enclosed-style Gortrac steel XL carrier in steel cable heat-treating application for unsupported long travel. Armor plates protect cables in aggressive environments.

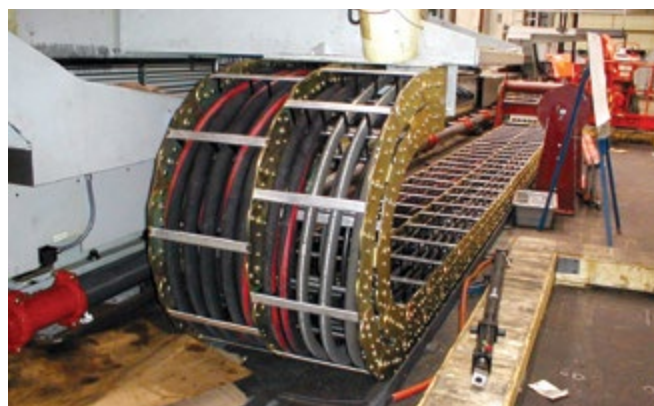

Nested Gortrac steel XL carrier system used on a large machining center for the aerospace industry.

HOW TO SIZE YOUR CARRIER

STEP 1: List all cables and hoses.

STEP 2: Determine minimum cavity height (**dimension B**) by adding a safety factors to the outer diameter of the largest cable or hose.

Safety Factors

- Cables: + 10%
- Hoses: + 20%
- Total ideal fill: 60%

STEP 3: Determine cavity width (**dimension A**) by adding the outer diameters and appropriate safety factors (see Step 2) of all cables and hoses. If using vertical cavity separators, add separator width. If using horizontal cavity dividers, be sure that the same safety factors apply and there is adequate vertical space between dividers. (See page 25 for carrier installation instructions.)

STEP 4: Consult the Quick Selection Guide sizing index for a pre-selection of appropriate series found on page 23.
(Or online: Dynatect.com/Gortrac-Design-Guide)

STEP 5: Check outer width (**dimension C**) and outer height (**dimension D**) dimensions against potential space restrictions.

STEP 6: Select carrier bend radius (**dimension R**) of carrier by consulting cable/hose manufacturer's specifications.

STEP 7: Check depot (**dimension K**) and curve height (**dimension H**) dimensions against potential space restrictions*.

STEP 8: Determine total required machine travel (total travel). To minimize carrier length, fixed end of carrier should be mounted at center of travel, when possible.

STEP 9: Consult the specifications page for curve length (**dimension CL**) of the chosen carrier.

STEP 10: Calculate Carrier Length:
Carrier Length = (Total machine travel/2) + CL (curve length) + Offset distance from center of travel*

*If fixed end is not mounted at center of travel. For minimum carrier length, moving bracket should be mounted directly above fixed bracket when machine is in center of travel. Offset is the dimension between fixed and moving bracket at center of travel.

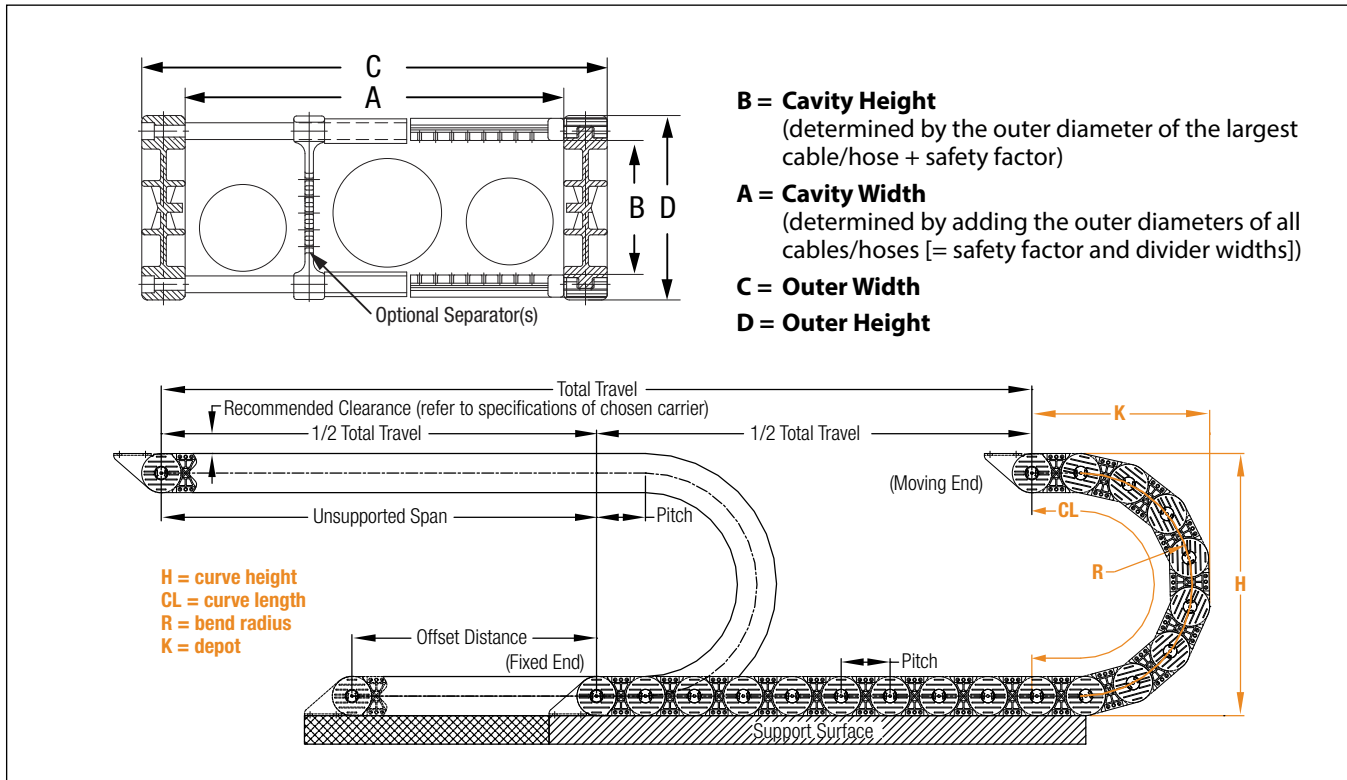

CABLE CARRIERS | QUICK SELECTION GUIDE

SERIES	INNER HEIGHT Dimension B inches (mm)	INNER WIDTH Dimension A inches (mm)	OUTER HEIGHT Dimension D inches (mm)	OUTER WIDTH Dimension C inches (mm)	MINIMUM BEND RADIUS Dimension R inches (mm)	MOUNTING HEIGHT Dimension h inches (mm)
NYLATRAC® & NYLATUBE® PLASTIC CABLE CARRIERS						
KO/KN	.28 (7) - .40 (10)	.28 (7) - 1.87 (47)	.39 (10) - .59 (15)	.47 (12) - 2.36 (60)	.59 (15) - 1.20 (30)	1.57 (40) - 3.00 (76)
KOE	.39 (10) - 1.50 (38)	.95 (24) - 5.28 (134)	.59 (15) - 1.97 (50)	1.42 (36) - 5.91 (150)	1.18 (30) - 5.91 (150)	3.00 (76) - 13.80 (351)
NSB	.62 (16) - .73 (19)	Customer Specified	1.38 (35)	S.W.+ .94 (24)	2.39 (61) - 3.06 (78)	6.19 (157) - 7.63 (194)
SP	.78 (20)	.59 (15) - 4.00 (102)	1.05 (27)	1.05 (27) - 4.46 (113)	1.05 (27) - 3.73 (95)	3.15 (80) - 8.50 (216)
N	.90 (23) - 2.24 (57)	.90 (23) - 5.28 (134)	1.38 (35) - 2.95 (75)	1.38 (35) - 5.91 (150)	3.30 (84) - 11.81 (300)	8.00 (203) - 26.60 (676)
KS	1.06 (27)	1.00 (25) - 4.00 (102)	1.37 (35)	1.56 (40) - 4.56 (116)	2.02 (51) - 5.87 (149)	5.40 (137) - 13.00 (330)
P/PH	1.32 (34)	1.25 (32) - 4.00 (102)	1.50 (38)	1.72 (44) - 4.47 (114)	1.25 (32) - 4.25 (108)	4.00 (102) - 10.00 (254)
NP	1.54 (39)	2.00 (51) - 6.00 (152)	2.00 (51)	2.63 (67) - 6.63 (168)	2.50 (64) - 7.87 (200)	7.00 (178) - 18.00 (457)
TSC	1.52 (39) - 1.65 (42)	Customer Specified	2.30 (58)	S.W. + .85 (22)	2.95 (75) - 13.78 (350)	8.20 (208) - 29.86 (758)
KL	1.75 (44)	3.00 (76) - 7.00 (178)	2.50 (64)	3.75 (95) - 7.75 (197)	3.00 (76) - 11.75 (298)	8.50 (216) - 26.00 (660)
KLE	1.76 (45)	3.00 (76) - 7.00 (178)	2.50 (64)	3.75 (95.25) - 7.75 (197)	3.75 (95) - 11.75 (298)	10.00 (254) - 26.00 (660)
TS	2.13 (54) - 2.38 (60)	Customer Specified	3.25 (82)	S.W. + 1.52 (39)	3.88 (99) - 16.13 (410)	11.00 (279) - 35.50 (902)
TL	2.88 (73) - 3.05 (78)	Customer Specified	4.13 (105)	S.W. + 1.94 (49)	5.81 (148) - 24.69 (627)	15.75 (400) - 53.50 (1359)
NXL	3.94 (100) - 4.77 (121)	Customer Specified	5.91 (150)	S.W. + 2.50 (64)	9.05 (230) - 27.05 (687)	24.00 (610) - 60.00 (1524)
GORTRAC® & GORTUBE® METAL CABLE CARRIERS						
SA	.89 (22)	.94 (24)	1.00 (25)	1.29 (33)	1.25 (32)	3.50 (89)
SB/SC	.62 (16) - 1.38 (35)	Customer Specified	1.38 (35) / 2.00 (51)	S.W. + .50 (13)	2.06 (52) - 5.62 (143)	5.50 (140) - 13.25 (337)
Gortube	.62 (16) - 4.02 (102)	.90 (23) - 8.35 (121)	.79 (20) - 4.33 (110)	1.18 (30) - 8.66 (220)	1.80 (46) - 13.80 (351)	4.40 (112) - 30.70 (780)
MRC	1.08 (27) - 1.25 (32)	Customer Specified	2.00 (51)	S.W. + .62 (16)	2.75 (70) - 7.50 (191)	7.50 (191) - 17.00 (432)
GX	1.51 (38) - 1.70 (43)	2.25 (57) - 7.00 (178)	2.00 (51)	2.69 (68) - 7.44 (189)	2.00 (51) - 5.63 (143)	6.00 (152) - 13.25 (337)
SX	1.76 (45) - 2.00 (51)	Customer Specified	3.20 (81)	S.W. + .58 (15)	3.47 (88) - 12.06 (306)	10.13 (257) - 27.31 (694)
SRC/LRC	1.76 (45) - 2.97 (75)	Customer Specified	3.00 (76) / 4.00 (102)	S.W. + .69 (18)	4.00 (102) - 24.25 (616)	11.00 (279) - 52.50 (1334)
XX	4.18 (106) - 4.40 (112)	Customer Specified	6.00 (152)	S.W. + 0.81 (21)	10.00 (254) - 27.00 (686)	26.00 (660) - 60.00 (1,524)
XL	3.86 (98) - 8.32 (211)	Customer Specified	5.91 (150) - 9.84 (250)	S.W. + 1.25 (32)	10.05 (255) - 35.08 (891)	26.00 (660) - 80.00 (2,032)

S.W. = Specified Inner Width

Series are roughly sorted by inner (cavity) height.

For enclosed-style carrier options, see: KOE, N, KLE, TSC, TS, TL, NXL, Gortube, SRC, LRC and XL Series.

Consult load charts on Dynatect.com for maximum unsupported span.

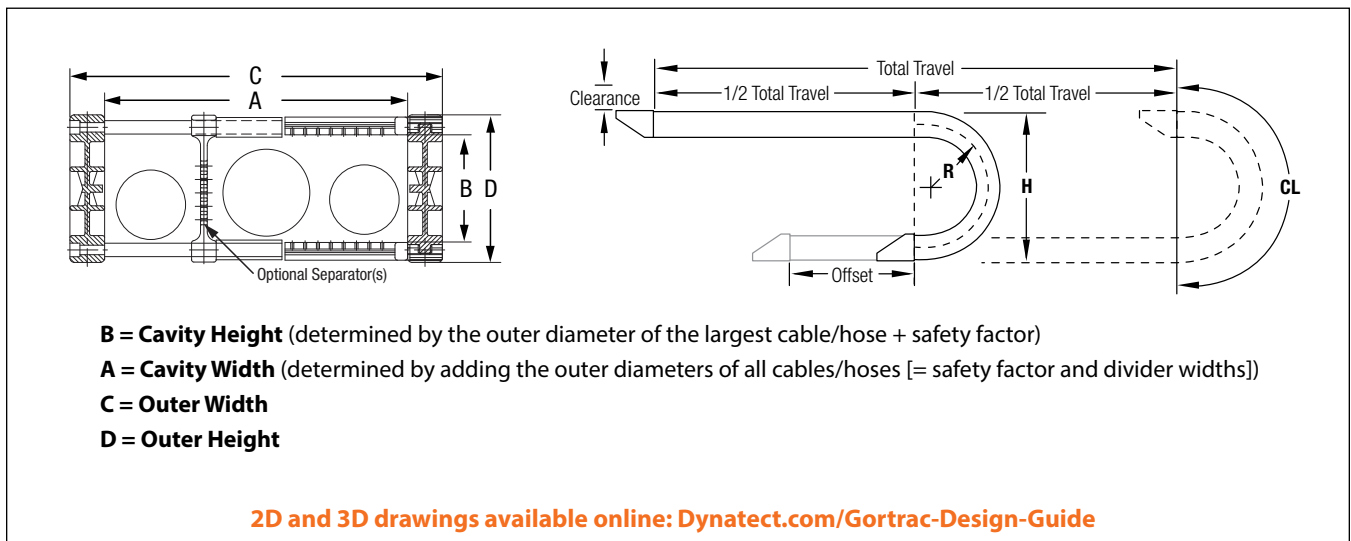

TYPICAL APPLICATIONS

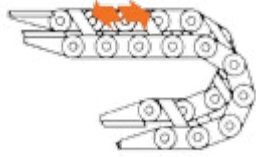

Horizontal Lower-Flange Fixed

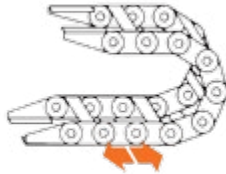

Horizontal Upper-Flange Fixed



Vertical Curve Down

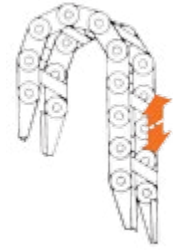

Vertical Curve Up

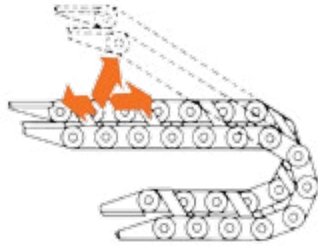

Combination Vertical and Horizontal

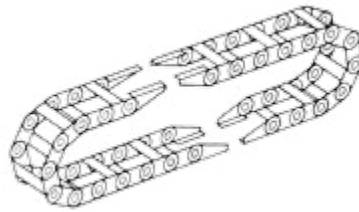

Opposed

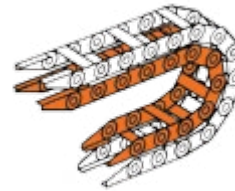

Nested Configuration



Side Mounted

TERMS AND DEFINITIONS

Carrier Length = (Total Machine Travel/2) + Curve Length + Offset

For minimum carrier length, moving bracket should be mounted directly above fixed bracket when machine is in center of travel. Offset is the dimension between fixed and moving bracket at center of travel.

Curve Height (H)

The overall height of the carrier at the loop. While (H) is the designed height at the loop, clearance should be provided above the carrier. This will be true of either metal or plastic carrier to account for built-in camber. Gortrac® carriers have a positive camber or pre-tension designed into the links in order to provide additional self-supporting length in horizontally oriented applications. This camber adds to the clearance required above the track. (See "Recommended Clearance" specification). In applications with limited space or non-horizontal orientations, this camber can be reduced or eliminated. For details, including any resulting reductions in unsupported span, please contact your Dynatect representative.

Carrier Bend Radius (R)

Minimum bend radius of the cable and hose carrier should be larger than the recommended bend radius of the stiffest cable or hose installed in the carrier. Consult with cable or hose manufacturer for recommended bend radius.

Curve Length (CL) = (π x Radius 'R') + (Pitch x 2)

Curve length is dependent on radius and link pitch – refer to Series specifications.

Pitch

Refers to the distance between the pivot point centerlines of adjacent links.

Depot (K)

The centerline from the first link pivot point to the end of the carrier in retraction.

Load

The total weight of the cables and hoses within the carrier. This is usually called out in pounds per foot. If hoses will contain liquid, please include that weight.

Maximum Speed

The maximum velocity of the moving end of the carrier during its travel.

Maximum Acceleration

The maximum acceleration of the moving end of the carrier during its travel.

Unsupported Span

Every carrier has an unsupported span. This span is a condition of link construction and the fill weight of the cables and hoses being carried. As the unsupported span of the carrier is exceeded, the carrier begins to sag. Dynatect will recommend proper support guidance when carrier fill weight exceeds its free carrying length. Refer to Series specifications for load charts.

Metal vs. Plastic Carriers

Dynatect offers plastic, metal and hybrid carriers to satisfy the broadest range of applications. In general, use Gortrac steel carriers with elevated operating temperatures or when heavy loads exceed the maximum unsupported travel of plastic carriers. Use Gortrac steel carriers with lower speeds; however, higher speeds have been achieved with control of acceleration and deceleration. Plastic carriers are usually the first choice in applications requiring higher speeds and accelerations and long travel.

Gortrac steel link carriers have the highest strength-to-weight ratio and maximum unsupported span capability. Dynatect offers several lightweight steel carriers that are competitively priced with plastic, while providing significantly greater strength than similar-sized plastic carriers.

Open-Style vs. Enclosed- Style Carriers

Dynatect offers both open and enclosed style options. Open-style carriers provide easy cable/hose inspection, while enclosed-style carriers offer protection from damaging outside elements such as hot chips.

CABLE/HOSE CARRIER | INSTALLATION GUIDE

Special care and consideration should be taken while installing cables and hoses. The correct installation of cables and hoses is one of the most important aspects of the entire system. Proper installation will greatly affect the cable

carrier system cycle life, as well as the cycle life of the cables and hoses. The following guidelines should be followed to maximize the life of the cables and cable carrier system.

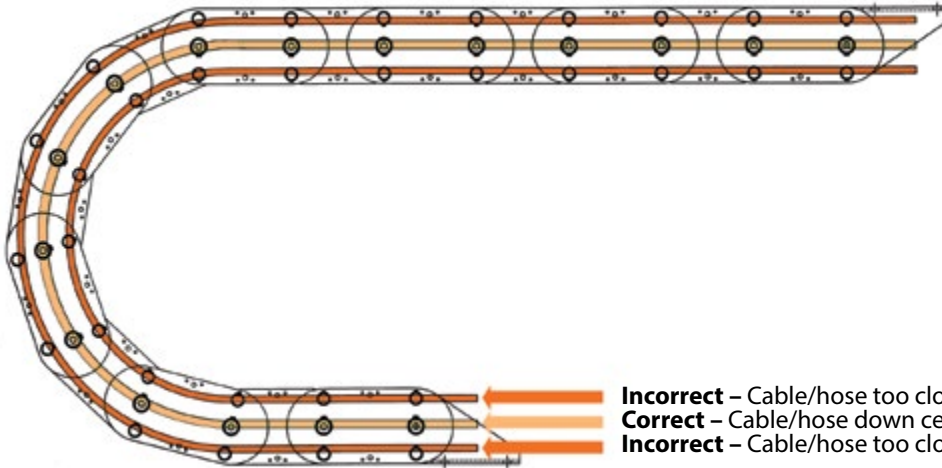

Incorrect – Cable/hose too close to inner diameter
Correct – Cable/hose down centerline of carrier
Incorrect – Cable/hose too close to outer diameter

Recommended Cable/Hose Placement

The cables/hoses must not be twisted and should be free of kinks or other irregularities. When stacking cables/hoses, care should be taken to ensure enough slack has been provided to allow cables/hoses to travel freely on top of one another.

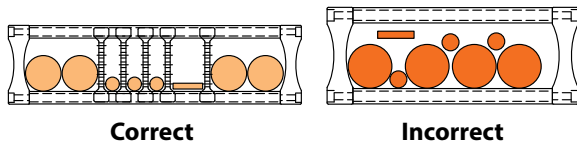

The stacking or direct side-by-side placement of cables and hoses with large cross-sectional differences is not recommended.

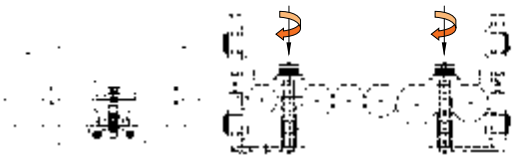

All cables and hoses should be secured at both the fixed and moving ends. Please do not pinch the cables/hoses excessively while clamping the ends in place. In applications with high pressure hydraulic hoses, we recommend clamping only at the moving end of the carrier.

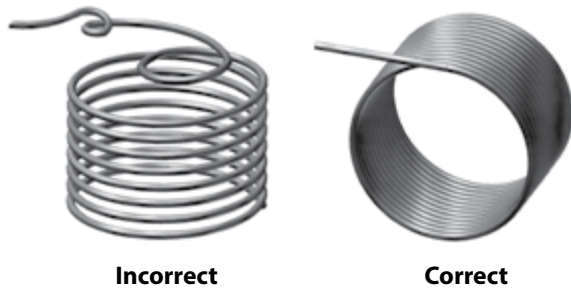

Make certain that the cable/hoses are laid into the carrier "twist-free". Cables/hoses supplied in rolls or on roll reels should be unrolled, not pulled sideways or off the top of the coil.

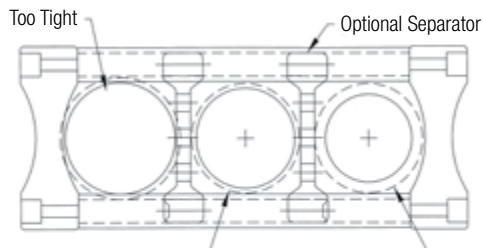

Recommended 10% Clearance for Cables Recommended 20% Clearance for Hoses

Dynatect recommends a minimal 10% clearance for each cable overall diameter and 20% clearance for each hose overall diameter. (60% total cavity fill optimal)

CROSSBARS STYLES AND OPTIONS & ACCESSORIES

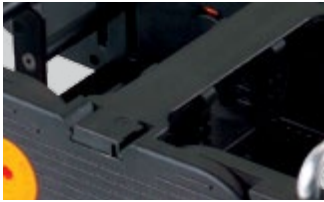

PLASTIC CROSSBARS

Lightweight, quick installation and easy maintenance. Fixed, snap-in or hinged crossbar designs. Custom widths on modular carriers.



PLASTIC LIDS (MODULAR PLASTIC)

Protect against dust and light abrasives. Customer-specified width. Snap-in design allows cavity access with tip of a screw driver.



ALUMINUM CROSSBARS

High-strength alternative to standard plastic bars. Customer specified width. Design options: bolt-in flat bar for maximum torsional stability, or snap-in for quick cavity access.

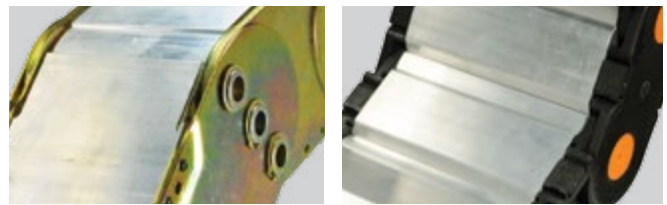

ARMOR PLATE STYLE ALUMINUM LIDS

Maximum protection against hot chips and heavy abrasives. Ideal for severe environments such as machining, mills, and foundries. Heavy-duty bolted construction on metallic carriers; snap-in option on modular plastic carriers.

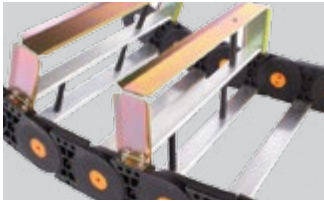

WINDOW EXTENDERS

Window extenders provide extra interior space. Available in both standard and custom configuration. Made from various crossbar styles (flat, round, poly roller, or custom-formed). Extenders can be added to most carriers.

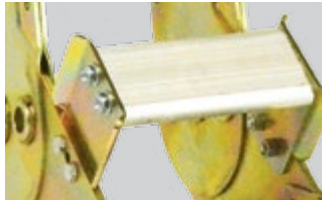

PVC POLY ROLLERS

Poly rollers provide a low-friction, mechanical wear surface ideal for hoses and soft-jacketed cables. Poly rollers can be added to crossbars, vertical separators or horizontal dividers using round bars. Available on any carrier with aluminum round bars.

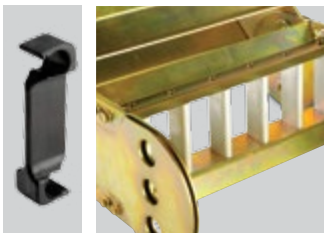

CAVITY SEPARATION

In applications with multiple cables and hoses, cavity separation is a simple, cost-effective method for preventing wear and entanglement. To achieve optimal separation, it is important that each individual compartment be less than twice the height of the cables/hoses inside. This will prevent them from crossing over each other and twisting. Proper separation reduces jacket wear and the potential for cables to corkscrew. Cavity separation can be achieved with simple, snap-in vertical separators, or through a more sophisticated horizontal divider or shelving system that will optimize cavity space.



VERTICAL SEPARATORS

Vertical separators provide multiple compartments within a single link. Separators bolt or snap into carrier crossbars and are available in many styles, including stationary and rolling designs. Available on most carriers. Separators can be installed every link or staggered for economy. When sizing compartments, Dynatect recommends a safety factor of an additional 10% for cables and 20% for hoses.

CABLE CARRIER OPTIONS & ACCESSORIES

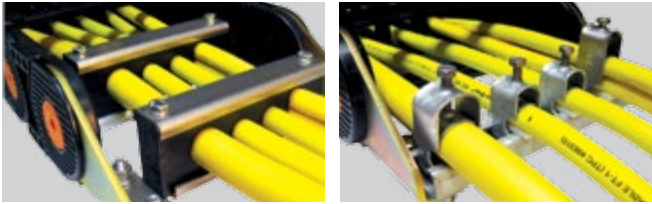

CABLE/HOSE CLAMPS

Clamps extend life by relieving cable/hose strain. Standard and custom designs available. Installation at both moving and stationary ends of a carrier recommended. High pressure hose clamping requirements can be accommodated.



MACHINED CABLE/HOSE BARS

Ideal for optimal placement of cables and hoses, and restricting movement to the neutral axis of carrier. Jacket and conductor life prolonged due to minimal wear of properly secured cables/hoses. Available in aluminum or plastic block-style crossbars and custom-bored to specific cable/hose diameters.

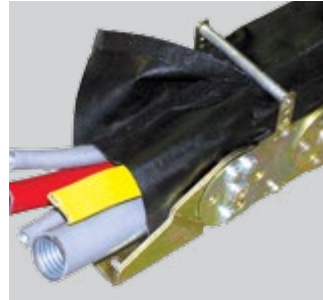

CABLE/HOSE SLEEVES

Protect cables/hoses in applications such as: hydraulic hose containment, protection of very sensitive cables, electrical noise interference. Available with zipper or hook & loop fasteners. Variety of material options.



Custom Mounting Bracket with Integrated Bulk-Head Plate

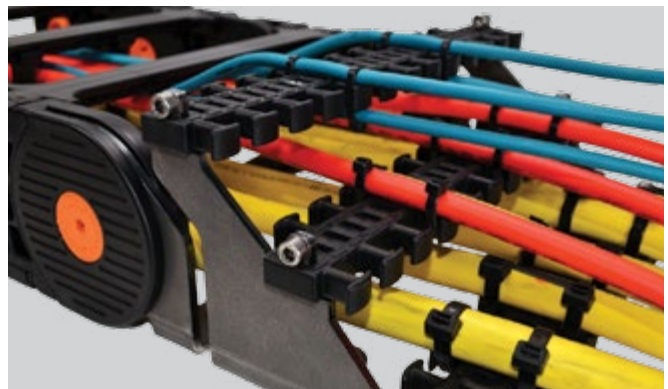

Zip Tie Bar for Mounting Brackets

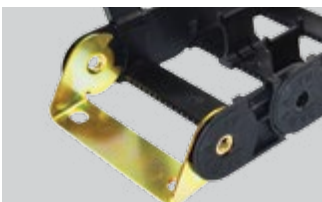

Standard One-Piece Bracket



Universal Mounting Bracket

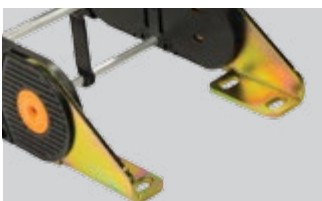

Standard Two-Piece Bracket



Strain Relief Bracket

MOUNTING OPTIONS

In addition to standard brackets, Dynatect offers other styles of brackets and options to simplify installation.

- Custom mounting brackets can be provided for drop-in replacement on all carrier brands
- Universal brackets are available
- Brackets with zip tie clamp bars can be added to the mounting brackets of many metallic and modular plastic carriers

KO / KN SERIES | NYLATRAC[®] STANDARD (open-style carriers)



KO SERIES

Features:

- Smallest accessible standard link
- Hinged crossbars on inside radius
- Integral mounting holes molded into every link (except KO-3) eliminate the need for mounting brackets

Quick Sizing Reference – inches (mm):

- Link Height: 0.39 - 0.87 (10 - 22)
- Link Pitch: 0.59 - 1.18 (15.00 - 30.00)
- Curve Heights ('H'): 1.57 - 6.38 (40 - 162)



KN SERIES

Features:

- Smallest solid standard link (crossbars do not hinge open)
- Integral mounting holes molded into every link eliminate the need for mounting brackets

Quick Sizing Reference – inches (mm):

- Link Height: 0.59 (15)
- Link Pitch: 0.79 (20)
- Curve Heights ('H'): 2.00 - 3.00 (51 - 76)

KO SERIES SPECIFICATIONS

MODEL NO.	A inches (mm)	C inches (mm)	WEIGHT lb/ft (kg/m)
K00	0.28 (7)	0.47 (12)	0.04 (0.06)
K0*	0.39 (10)	0.60 (15)	0.10 (0.15)
K02	0.97 (25)	1.47 (37)	0.14 (0.21)
K03	1.54 (39)	2.04 (52)	0.18 (0.27)
K04	1.87 (47)	2.36 (60)	0.20 (0.30)
K20	0.98 (25)	1.50 (38)	0.22 (0.33)
K30	1.42 (36)	1.89 (48)	0.25 (0.37)

KN SERIES SPECIFICATIONS

MODEL NO.	A inches (mm)	C inches (mm)	WEIGHT lb/ft (kg/m)
KN2	0.97 (25)	1.47 (37)	0.14 (0.21)
KN3	1.54 (39)	2.03 (52)	0.18 (0.27)
KN4	01.87 (47)	2.36 (60)	0.20 (0.30)

*Does not hinge open – requires plastic mounting brackets (all other KO Series carriers have brackets built into links).

CARRIER CROSS SECTION – Dimensions in inches (mm)

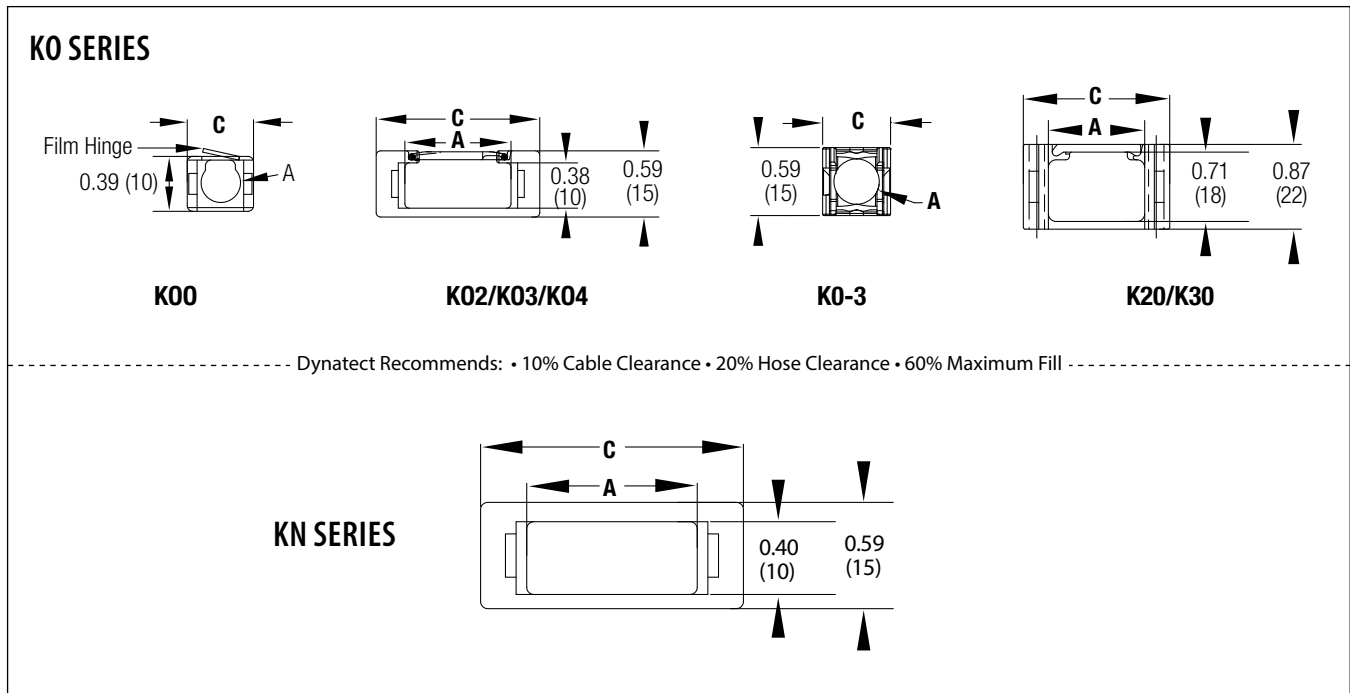

SP / KS SERIES | NYLATRAC® STANDARD (open-style carriers)



SP SERIES

Features:

- Hinged crossbars on inside (standard) or outside radius
- Strain relief mounting brackets are standard

Quick Sizing Reference – inches (mm):

- Link Height: 1.05 (27)
- Link Pitch Length: 1.20 (30)
- Curve Heights ('H'): 3.15 - 8.50 (80 - 216)



KS SERIES

Features:

- Hinged crossbars on inside (standard) or outside radius
- Standard one-piece mounting bracket; strain relief brackets optional

Quick Sizing Reference – inches (mm):

- Link Height: 1.38 (35)
- Link Pitch: 1.83 (46)
- Curve Height ('H') range: 5.40 - 13.10 (137 - 333)

SP SERIES SPECIFICATIONS

MODEL NO.	A inches (mm)	C inches (mm)	WEIGHT lb/ft (kg/m)
SP059	0.59 (15)	1.05 (27)	0.20 (0.30)
SP100	1.00 (25)	1.46 (37)	0.20 (0.30)
SP150	1.50 (38)	1.96 (50)	0.23 (0.34)
SP200	2.00 (51)	2.46 (62)	0.26 (0.39)
SP250	2.50 (64)	2.96 (75)	0.28 (0.42)
SP300	3.00 (76)	3.46 (88)	0.29 (0.43)
SP400	4.00 (102)	4.46 (113)	0.36 (0.54)

KS SERIES SPECIFICATIONS

MODEL NO.	A inches (mm)	C inches (mm)	WEIGHT lb/ft (kg/m)
KS100	1.00 (25)	1.52 (39)	0.40 (0.60)
KS150	1.50 (38)	2.02 (51)	0.44 (0.65)
KS225	2.25 (57)	2.77 (70)	0.51 (0.76)
KS300	3.00 (76)	3.52 (89)	0.54 (0.80)
KS400	4.00 (102)	4.52 (115)	0.60 (0.89)

Note: Hinged bars available on inner or outer radius. Please specify when ordering. (Hinged bars on inner radius is standard.)

CARRIER CROSS SECTION – Dimensions in inches (mm)

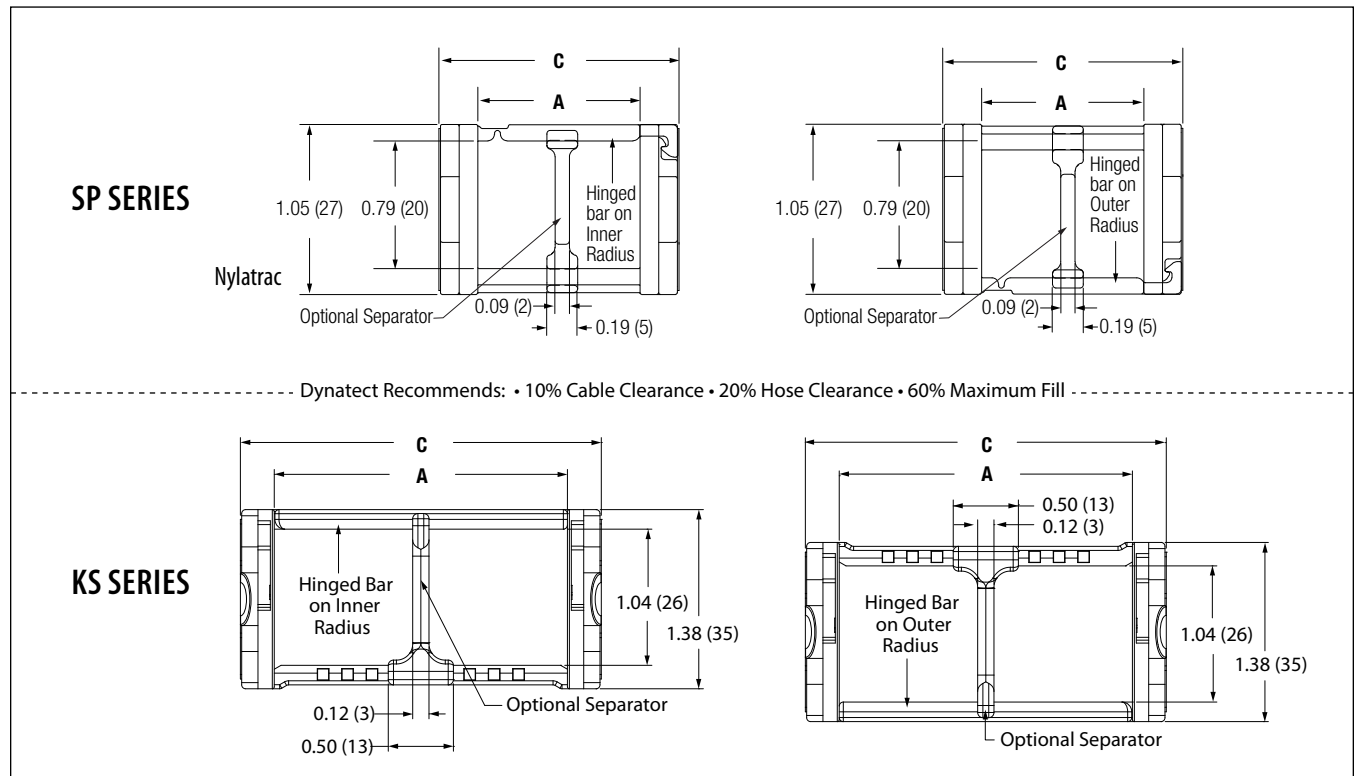

P / PH / NP SERIES | NYLATRAC[®] STANDARD (open-style carriers)



P/PH SERIES

Features:

- P models – Solid-link design
- PH models – Hinged crossbars on inside (standard) or outside radius
- Large window cavity relative to its overall dimensions

Quick Sizing Reference – inches (mm):

- Link Height: 1.50 (38)
- Link Pitch: 1.50 (38)
- Curve Height ('H') range: 4.00 - 10.00 (102 - 254)



NP SERIES

Features:

- Hinged crossbars on inside (standard) or outside radius
- Excellent strength for long travel applications

Quick Sizing Reference – inches (mm):

- Link Height: 2.00 (51)
- Link Pitch: 2.17 (55)
- Curve Height ('H') range: 7.00 - 18.00 (178 - 457)

P/PH SERIES SPECIFICATIONS

MODEL NO.	A inches (mm)	C inches (mm)	WEIGHT lb/ft (kg/m)
P1	1.25 (32)	1.72 (44)	0.35 (0.52)
PH1*	1.25 (32)	1.72 (44)	0.35 (0.52)
P2	2.50 (64)	2.97 (75)	0.41 (0.61)
PH2*	2.50 (64)	2.97 (75)	0.41 (0.61)
P3	4.00 (102)	4.47 (114)	0.49 (0.73)
PH3*	4.00 (102)	4.47 (114)	0.49 (0.73)

NP SERIES SPECIFICATIONS

MODEL NO.	A inches (mm)	C inches (mm)	WEIGHT lb/ft (kg/m)
NP200	2.00 (51)	2.63 (67)	0.72 (1.07)
NP250	2.50 (64)	3.13 (80)	0.74 (1.10)
NP300	3.00 (76)	3.63 (92)	0.78 (1.15)
NP400	4.00 (102)	4.63 (118)	0.85 (1.26)
NP500	5.00 (127)	5.63 (143)	0.95 (1.41)
NP600	6.00 (152)	6.63 (168)	1.03 (1.54)

*PH Series crossbars hinge open on both left and right sides for directional opening. Please specify inner or outer radius for hinged bars. (Inside radius is standard.)

Note: Hinged bars available on inner or outer radius. Please specify when ordering. (Hinged bars on inner radius is standard.)

CARRIER CROSS SECTION – Dimensions in inches (mm)

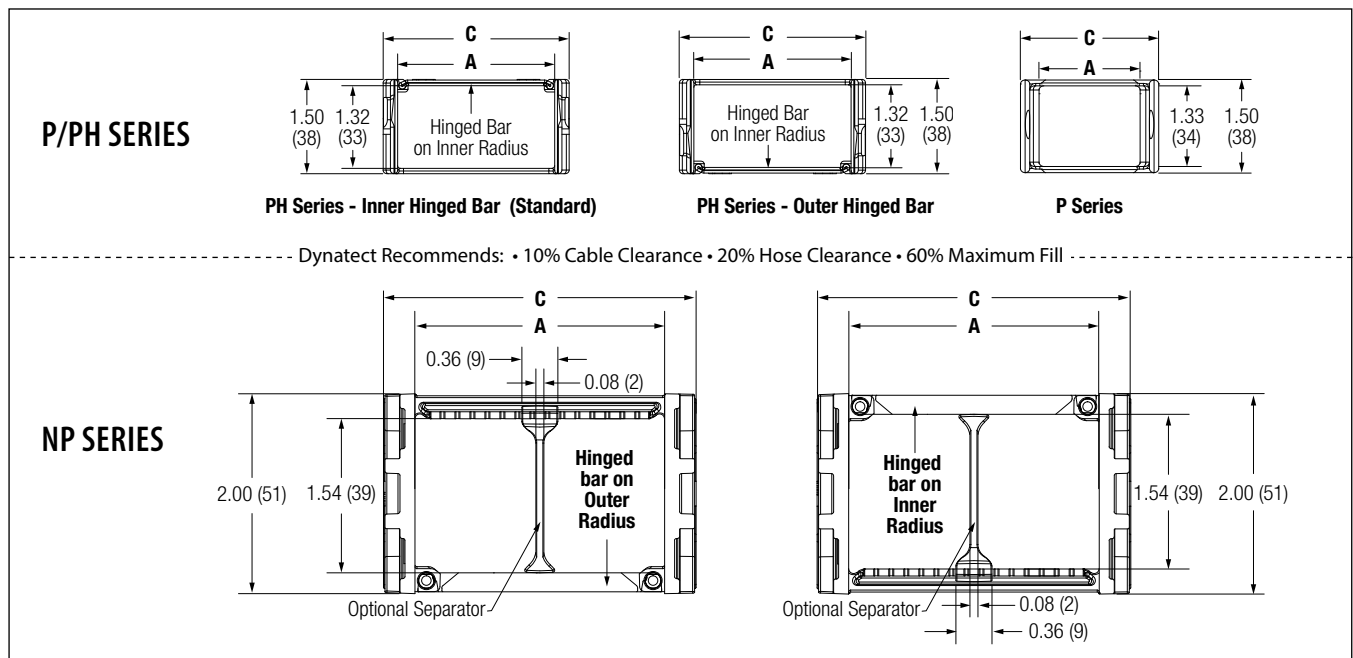

KL SERIES | NYLATRAC® STANDARD (open-style carriers)



Features:

- Hinged crossbars on outside radius
- Ideal for long travel applications
- Excellent strength and unsupported span rating

Quick Sizing Reference – inches (mm):

- Link Height: 2.50 (64)
- Link Pitch: 2.62 (67)
- Curve Height ('H') range: 8.50 - 26.00 (216 - 660)

KL SERIES SPECIFICATIONS

MODEL NO.	A inches (mm)	C inches (mm)	WEIGHT lb/ft (kg/m)
KL200*	2.00 (51)	2.75 (70)	1.00 (1.49)
KL1**	3.00 (76)	3.75 (95)	0.98 (1.46)
KL2	4.50 (114)	5.25 (133)	1.11 (1.65)
KL3	7.00 (178)	7.75 (197)	1.48 (2.20)

*New model: KL200-10 or KL200-15 – hinged bars available on inside (standard) or outside radius. When specifying, please note preferred location of hinged bars. **KL1 – optional single-piece cavity divider available.

CARRIER CROSS SECTION – Dimensions in inches (mm)

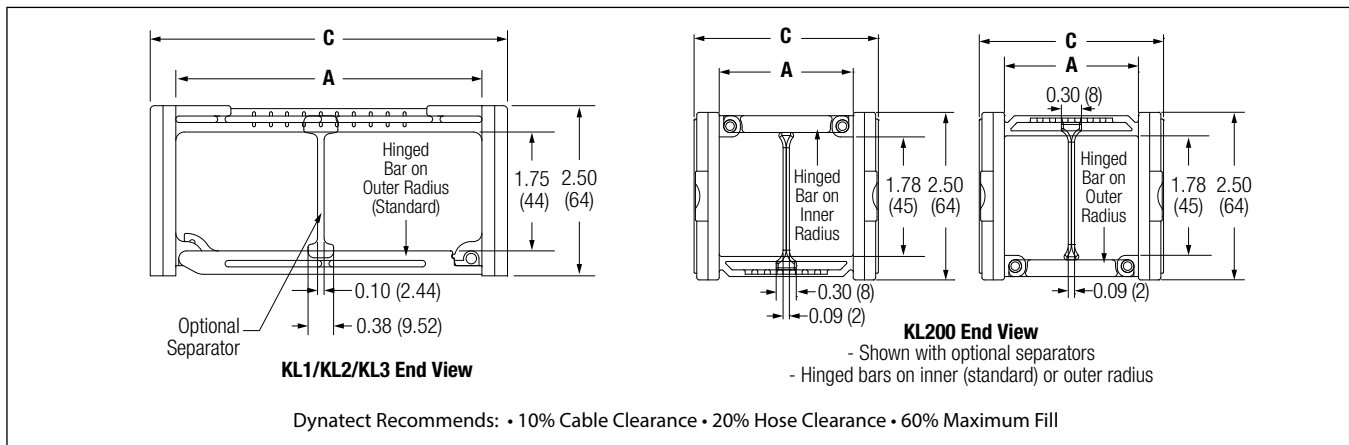

NSB SERIES | NYLATRAC® MODULAR (open-style carriers)



Features:

- Smallest link modular carrier
- Tongue-and-groove link design result in a nearly indestructible cable carrier
- Standard construction is round aluminum crossbar
- Customer-specified cavity width

Quick Sizing Reference – inches (mm):

- Link Height: 1.37 (35)
- Link Pitch: 1.97 (50)
- Curve Heights ('H'): 6.17 - 7.50 (157 - 191)

Crossbar Options:

- Bolted aluminum round bar (standard)
- PVC Poly rollers

NSB SERIES SPECIFICATIONS

MODEL NO.	A inches (mm)	C inches (mm)	WEIGHT lb/ft (kg/m)
NSB	Customer Specified	A + 0.94 (24)	0.70 (1.04)

Crossbar Styles:

RB = Bolted Aluminum Round Bar
PR = Poly Roller over Bolted Aluminum Round Bar

CARRIER CROSS SECTION – Dimensions in inches (mm)

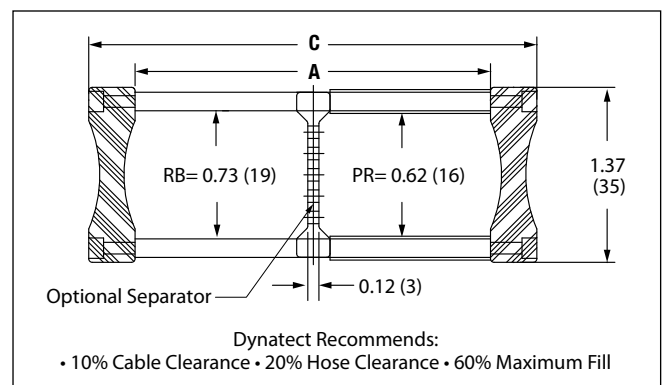

TSC SERIES | NYLATRAC® MODULAR (open-& enclosed-style carriers)



Features:

- Open-style with multiple crossbar options
- Enclosed-style with plastic lids
- Standard and customer-specified cavity widths
- Replaceable modular sliders available for low-friction and reduced tow force
- Window extenders available for additional cavity height

Crossbar Options:

- Snap-in plastic flat bar
- Bolted aluminum round bar
- PVC Poly Rollers
- Bolted aluminum flat bar

Lid Option:

- Snap-in plastic lid

Quick Sizing Reference – inches (mm):

- Link Height: 2.30 (58)
- Link Pitch: 2.64 (67)
- Curve Heights ('H'): 8.20 - 29.86 (208 - 758)

TSC SERIES SPECIFICATIONS

MODEL NO.	A inches (mm)	C inches (mm)	WEIGHT lb/ft (kg/m)
TSC218-F	2.18 (55)	3.03 (77)	1.09 (1.62)
TSC317-F	3.17 (81)	4.02 (102)	1.12 (1.67)
TSC368-F	3.68 (94)	4.53 (115)	1.14 (1.70)
TSC415-F	4.15 (105)	5.00 (127)	1.16 (1.73)
TSC513-F	5.13 (130)	5.98 (152)	1.19 (1.77)
TSC554-F	5.54 (141)	6.39 (162)	1.20 (1.79)
TSC597-F	5.97 (152)	6.82 (173)	1.20 (1.79)
TSC998-F	9.98 (253)	10.83 (275)	1.90 (2.83)
TSC-PR	Customer Specified	A + 0.85 (22)	0.88 (1.31)
TSC-RB	Customer Specified	A + 0.85 (22)	0.82 (1.22)
TSC-AF	Customer Specified	A + 0.85 (22)	1.15 (1.71)
TSC-PL***	Customer Specified	A + 0.85 (22)	1.47 (2.19)

Crossbar Styles (Top and Bottom):

F = Snap-In Plastic Flat Bar RB = Bolted Aluminum Round Bar PR = Poly Roller over Bolted Aluminum Round Bar
AF = Bolted Aluminum Flat Bar PL = Plastic Lid (Enclosed-Style Carrier)

Note: Modular low-friction sliders are optional.

***Plastic lids not available on 80, 110 or 115 height. Optional modular sliders not available on 80 or 100 height.

CARRIER CROSS SECTION – Dimensions in inches (mm)

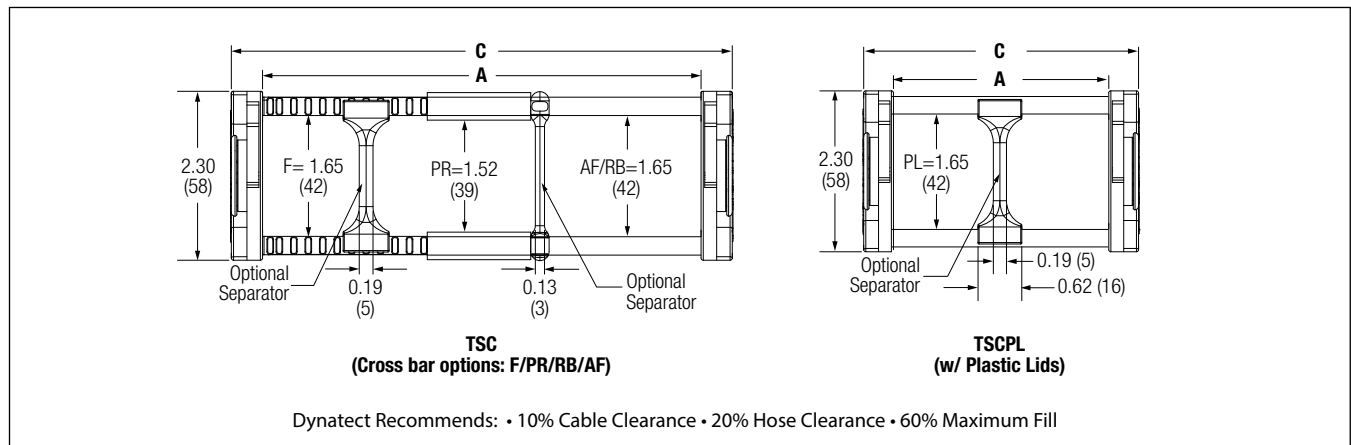

TS SERIES | NYLATRAC® MODULAR (open-& enclosed-style carriers)



Features:

- Open-style with multiple crossbar options
- Enclosed-style with plastic or aluminum lids
- Standard and customer-specified cavity widths
- Replaceable modular sliders available for low-friction and reduced tow force
- Window extenders available for additional cavity height

Quick Sizing Reference – inches (mm):

- Link Height: 3.25 (83)
- Link Pitch: 4.06 (103)
- Curve Heights ('H'): 11.00 - 35.50 (279 - 902)

Crossbar Options:

- Snap-in plastic flat bar
- Bolted aluminum round bar
- PVC Poly Rollers
- Bolted aluminum flat bar
- Snap-in aluminum flat bar

Lid Options:

- Snap-in plastic lid
- Bolted aluminum armor plate
- Snap-in aluminum armor plate

TS SERIES SPECIFICATIONS

MODEL NO.	A inches (mm)	C inches (mm)	WEIGHT lb/ft (kg/m)
TS293-F	2.93 (74)	4.45 (113)	2.40 (3.57)
TS387-F	3.87 (98)	5.35 (136)	2.50 (3.72)
TS480-F	4.80 (122)	6.33 (161)	2.60 (3.87)
TS638-F	6.36 (162)	7.89 (200)	2.70 (4.02)
TS762-F	7.62 (194)	9.14 (232)	2.80 (4.17)
TS805-F	8.05 (205)	9.57 (243)	2.85 (4.25)
TS980-F	9.79 (249)	11.32 (288)	2.90 (4.32)
TS1101-F	11.01 (280)	12.53 (318)	2.95 (4.39)
TS1148-F	11.48 (292)	13.00 (330)	3.00 (4.46)
TS1169-F	11.68 (297)	13.21 (336)	3.00 (4.46)
TS1357-F	13.57 (345)	15.09 (383)	3.10 (4.61)
TS-PS	Customer Specified	A + 1.52 (39)	3.31 (4.92)
TS-RB / TS-PR	Customer Specified	A + 1.52 (39)	TS-RB = 2.45 (3.65) / TS-PR = 2.69 (4.00)
TS-AF / TS-AFS	Customer Specified	A + 1.52 (39)	TS-AF = 4.93 (7.34) / TS-AFS = 4.81 (7.16)
TS-PL / TS-AP	Customer Specified	A + 1.52 (39)	TS-PL = 4.33 (6.44) / TS-AP = 6.39 (9.51)

Crossbar Styles (Top and Bottom):

F / PS = Snap-In Plastic Flat Bar RB = Bolted Aluminum Round Bar PR = Poly Roller over Bolted Aluminum Round Bar
 AF = Bolted Aluminum Flat Bar AFS = Snap-In Aluminum Flat Bar
 PL = Plastic Lid (Enclosed-Style Carrier) AP = Aluminum Armor Plate (Enclosed-Style Carrier)

CARRIER CROSS SECTION – Dimensions in inches (mm)

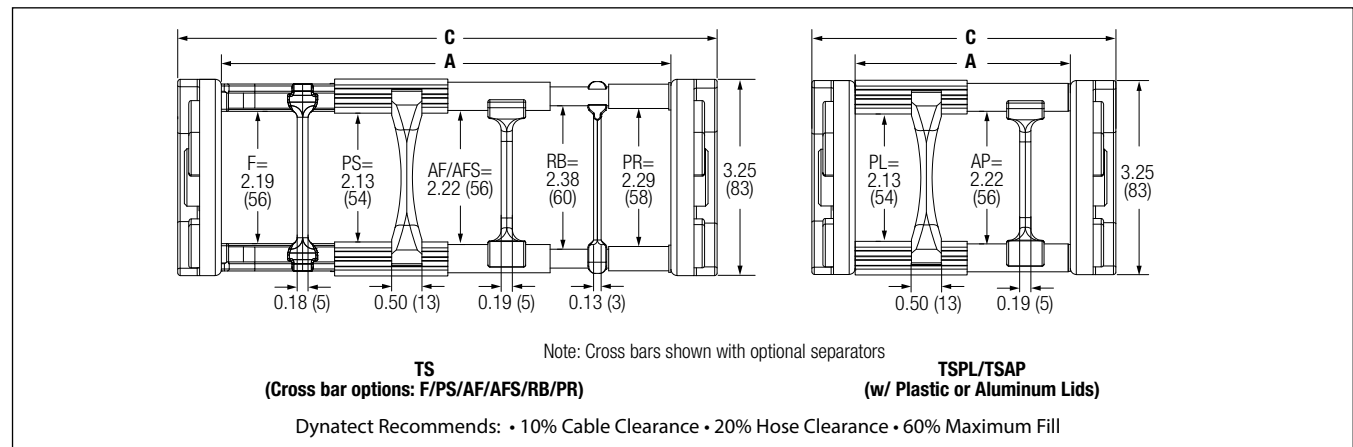

TL SERIES | NYLATRAC[®] MODULAR (open- & enclosed-style carriers)



Features:

- Open-style with multiple crossbar options
- Enclosed-style with plastic or aluminum lids
- Standard and customer-specified cavity widths
- Replaceable modular sliders available for low-friction and reduced tow force
- Window extenders available for additional cavity height

Crossbar Options:

- Snap-in plastic flat bar
- Bolted aluminum round bar
- PVC Poly Rollers
- Bolted aluminum flat bar
- Snap-in aluminum flat bar

Lid Options:

- Snap-in plastic lid
- Bolted aluminum armor plate
- Snap-in aluminum armor plate

Quick Sizing Reference – inches (mm):

- Link Height: 4.13 (105)
- Link Pitch: 5.16 (131)
- Curve Heights ('H'): 15.75 - 53.50 (400 - 1359)

TL SERIES SPECIFICATIONS

MODEL NO.	A inches (mm)	C inches (mm)	WEIGHT lb/ft (kg/m)
TL394F	3.94 (100)	5.87 (149)	2.80 (4.17)
TL466F	4.66 (118)	6.59 (168)	2.85 (4.24)
TL573F	5.73 (146)	7.67 (195)	2.90 (4.32)
TL789F	7.88 (200)	9.82 (249)	2.95 (4.39)
TL968F	9.68 (246)	11.62 (295)	3.00 (4.46)
TL1184F	11.84 (300)	13.77 (350)	3.05 (4.54)
TL1363F	13.63 (346)	15.57 (395)	3.10 (4.61)
TS-PS	Customer Specified	A + 1.94 (49)	4.03 (5.99)
TL-RB / TL-PR	Customer Specified	A + 1.94 (49)	TL-RB = 3.42 (5.09) / TL-PR = 3.72 (5.54)
TL-AF / TL-AFS	Customer Specified	A + 1.94 (49)	TL-AF = 5.21 (7.76) / TL-AFS = 5.12 (7.62)
TL-PL / TL-AP	Customer Specified	A + 1.94 (49)	TL-PL = 5.21 (7.75) / TL-AP = 7.56 (11.25)

Crossbar Styles (Top and Bottom):

F / PS = Snap-In Molded Plastic Flat Bar RB = Bolted Aluminum Round Bar PR = Poly Roller over Bolted Aluminum Round Bar
 AF = Bolted Aluminum Flat Bar AFS = Snap-In Aluminum Flat Bar PL = Plastic Lid (Enclosed-Style Carrier)
 AP = Aluminum Armor Plate (Enclosed-Style Carrier)

CARRIER CROSS SECTION – Dimensions in inches (mm)

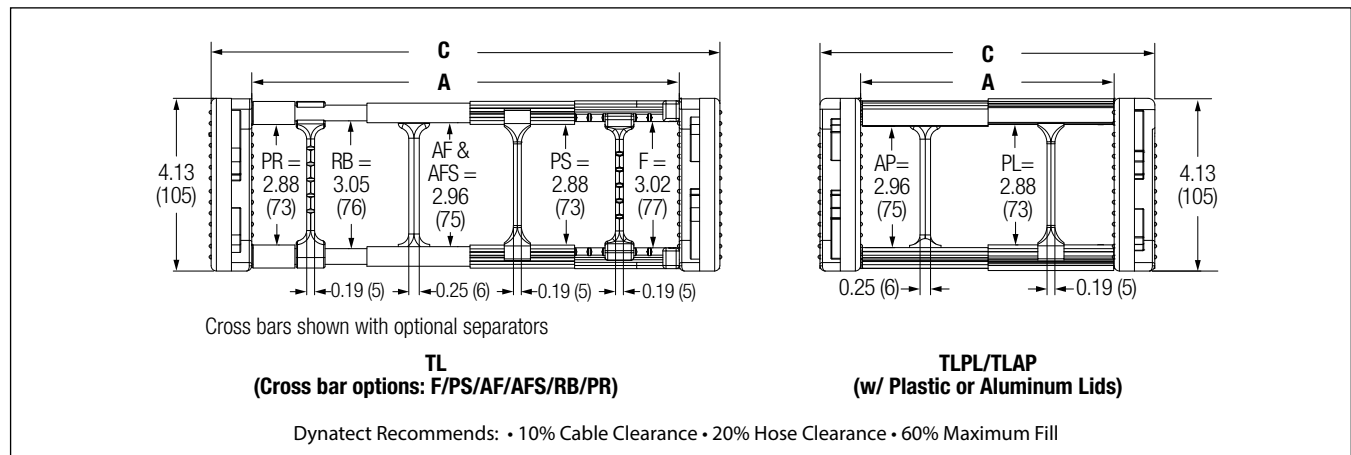

NXL SERIES | NYLATRAC® MODULAR (open- & enclosed-style carriers)



Features:

- Open-style with multiple crossbar options
- Enclosed-style with aluminum lids
- Customer-specified cavity widths
- Window extenders available for additional cavity height

Quick Sizing Reference – inches (mm):

- Link Height: 5.91 (150)
- Link Pitch: 7.38 (187)
- Curve Heights ('H'): 24.00 - 60.00 (610 - 1524)

Crossbar Options:

- Bolted aluminum round bar
- PVC Poly Rollers
- Bolted aluminum flat bar

Lid Option:

- Bolted aluminum armor plate

NXL SERIES SPECIFICATIONS

MODEL NO.	A inches (mm)	C inches (mm)	WEIGHT lb/ft (kg/m)
NXL-CC/AF/PR/RB	Customer Specified	A + 2.50 (64)	6.34 (9.43)
NXL-AP	Customer Specified	A + 2.50 (64)	10.40 (—)

Crossbar Styles:

AF = Bolted Aluminum Flat Bar RB = Bolted Aluminum Round Bar
PR = Poly Roller over Bolted Aluminum Round Bar AP = Aluminum Armor Plate (Enclosed-Style Carrier)

CARRIER CROSS SECTION – Dimensions in inches (mm)

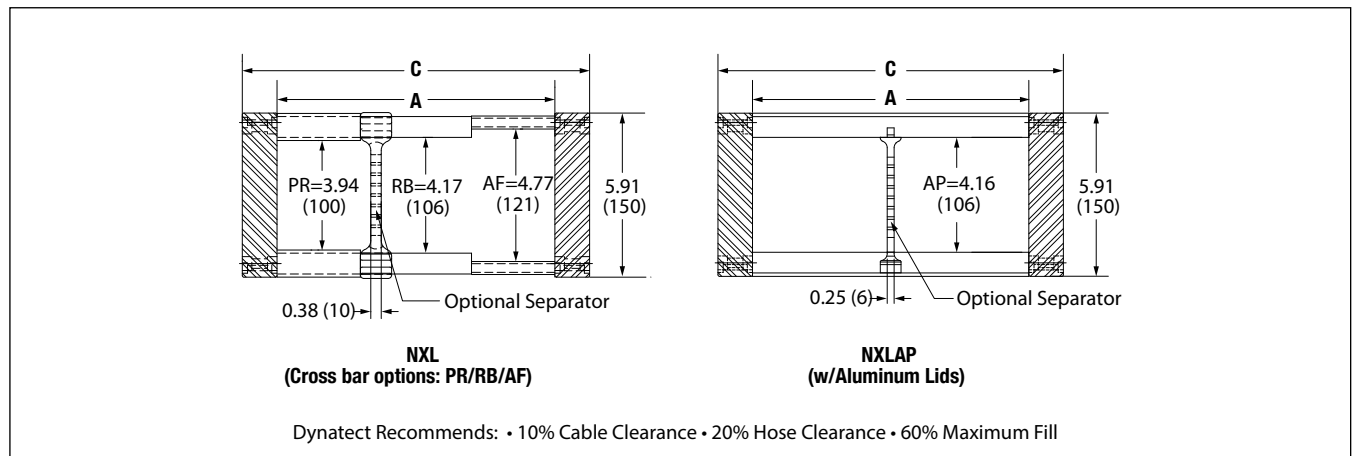

KOE / N / KLE SERIES | NYLATUBE[®] STANDARD (enclosed-style carriers)



KOE SERIES

Features:

- Small to medium range of link sizes
- Hinge-open lids on outside radius
- Integral mounting holes molded into every link eliminate the need for mounting brackets

Quick Sizing Reference – inches (mm):

- Link Height: 0.59 - 1.97 (15 - 50)
- Link Pitch: 0.71 - 2.17 (18 - 55)
- Curve Heights ('H') range: 3.00 - 13.80 (76 - 351)



N SERIES

Features:

- Small to large range of link sizes
- Solid, enclosed link design and smooth appearance

Quick Sizing Reference – inches (mm):

- Link Height: 1.38 - 2.95 (35 - 75)
- Link Pitch: 1.38 - 2.56 (35 - 65)
- Curve Height ('H') range: 8.00 - 26.60 (203 - 676)



KLE SERIES

Features:

- Medium size link available in 3 standard widths (3", 4.5", 7")
- Hinge-open lids on outside radius
- Designed for superior durability – excellent for heavy-duty and long travel applications

Quick Sizing Reference – inches (mm):

- Link Height: 2.50 (64)
- Link Pitch: 2.13 (54)
- Curve Height ('H') range: 10.00 - 6.00 (254 - 660)

CARRIER CROSS SECTION – Dimensions in inches (mm)

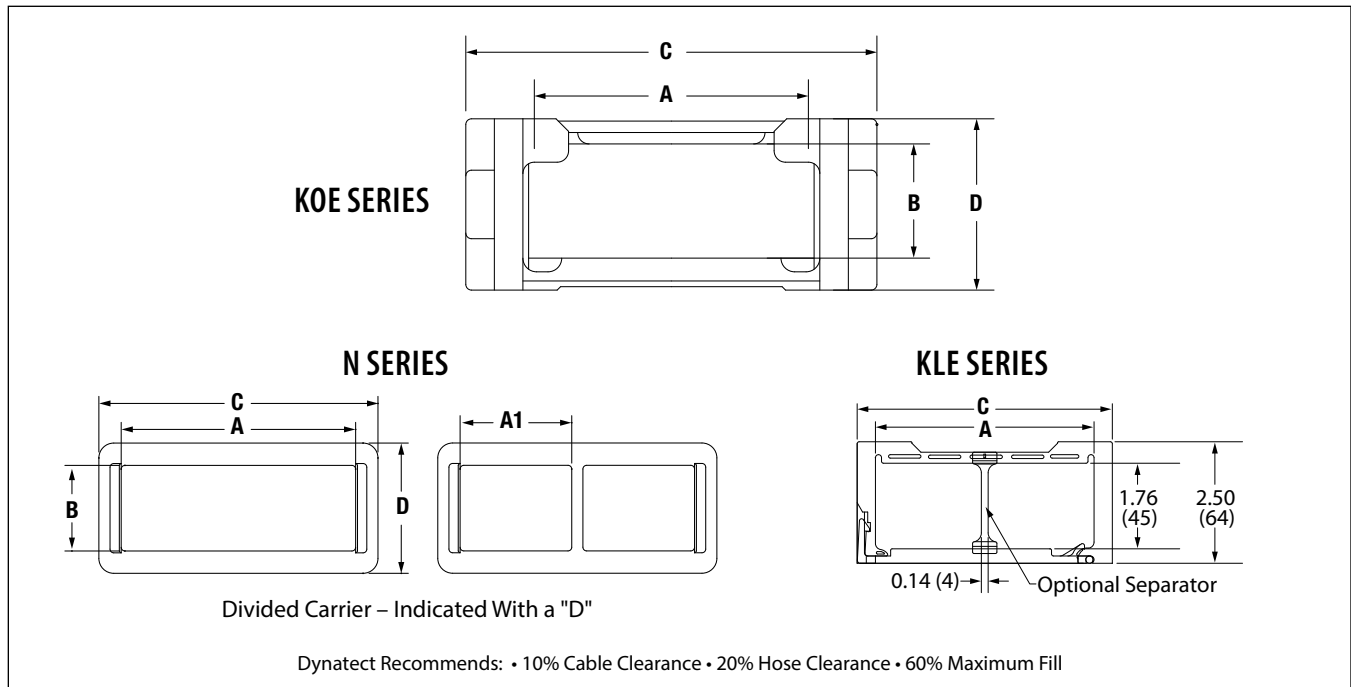

KOE / N / KLE SERIES | NYLATUBE® STANDARD (enclosed-style carriers)

KOE SERIES SPECIFICATIONS

MODEL NO.	A inches (mm)	B inches (mm)	C inches (mm)	D inches (mm)	WEIGHT lb/ft (kg/m)
KOE1	0.95 (24)	0.39 (10)	1.42 (36)	0.59 (15)	0.19 (0.28)
KOE3	1.34 (34)	0.83 (21)	1.97 (50)	1.18 (30)	0.44 (0.65)
KOE4	1.89 (48)	1.18 (30)	2.44 (62)	1.58 (40.13)	0.61 (0.91)
KOE5	1.89 (48)	1.50 (38)	2.56 (65)	1.97 (50)	0.87 (1.29)
KOE6	5.28 (134)	1.50 (38)	5.91 (150)	1.97 (50)	1.28 (1.90)

N SERIES SPECIFICATIONS

MODEL NO.	A inches (mm)	A1 inches (mm)	B inches (mm)	C inches (mm)	D inches (mm)	WEIGHT lb/ft (kg/m)
N1	0.90 (23)	—	0.90 (23)	1.38 (35)	1.38 (35)	0.50 (0.74)
N2	1.34 (34)	—	0.90 (23)	1.97 (50)	1.38 (35)	0.60 (0.89)
N3-D*	2.48 (63)	1.18 (30)	0.90 (23)	2.95 (75)	1.38 (35)	0.80 (1.19)
N4	1.42 (36)	—	1.34 (34)	1.97 (50)	1.97 (50)	0.80 (1.19)
N5	3.39 (86)	—	1.34 (34)	3.94 (100)	1.97 (50)	1.20 (1.79)
N5-D*	3.39 (86)	1.63 (41)	1.34 (34)	3.94 (100)	1.97 (50)	1.20 (1.79)
N6-D*	5.35 (136)	2.62 (67)	1.34 (34)	5.91 (150)	1.97 (50)	1.70 (2.53)
N8	5.28 (134)	—	2.24 (57)	5.91 (150)	2.95 (75)	2.20 (3.27)

*Designates divided carrier.

KLE SERIES SPECIFICATIONS

MODEL NO.	A inches (mm)	C inches (mm)	WEIGHT lb/ft (kg/m)
KLE1	3.00 (76)	3.75 (95)	1.25 (1.86)
KLE2	4.50 (114)	5.25 (133)	1.88 (2.80)
KLE3	7.00 (178)	7.75 (197)	2.92 (4.34)

SA / SB / SC SERIES | GORTRAC® STEEL (open-style carriers)



SA SERIES

Features:

- Standard construction: stainless steel link with double locking points and integral flat crossbars
- Custom option: zinc-dichromate plated steel
- Unique one-piece link design results in surprisingly lightweight carrier
- Integral flat crossbars provide added strength

- Self-cleaning link design expels debris from critical areas of the link during operation
- Small curve height

Quick Sizing Reference – inches (mm):

- Link Height: 1.00 (25)
- Link Pitch: 1.25 (32)
- Curve Height ('H'): 3.50 (89)



SB/SC SERIES

Features:

- Standard construction: stainless steel sidebands with round aluminum crossbars
- Custom option: zinc-dichromate plated stainless steel sidebands
- Lightweight carrier provides unsupported spans superior to plastic
- Unlimited cavity width flexibility

Quick Sizing Reference – inches (mm):
SB Series

- Link Height: 1.38 (35)
- Link Pitch: 2.00 (51)
- Curve Height ('H'): 5.50 (140)

Quick Sizing Reference – inches (mm):
SC Series

- Link Height: 2.00 (51)
- Link Pitch: 2.40 (61)
- Curve Heights ('H'):
7.50 – 13.25 (191 – 337)

SA SERIES SPECIFICATIONS

MODEL NO.	A inches (mm)	C inches (mm)	WEIGHT lb/ft (kg/m)
SA-35	0.94 (24)	1.29 (33)	0.70 (1.04)

Crossbar Styles: RB = Bolted Aluminum Round Bar
PR = Poly Roller over Bolted Aluminum Round Bar

SB/SC SERIES SPECIFICATIONS

MODEL NO.	A inches (mm)	C inches (mm)	WEIGHT lb/ft (kg/m)
SB	Customer Specified	A + 0.50 (13)	1.08 (1.61)
SC	Customer Specified	A + 0.50 (13)	1.72 (2.56)

CARRIER CROSS SECTION – Dimensions in inches (mm)

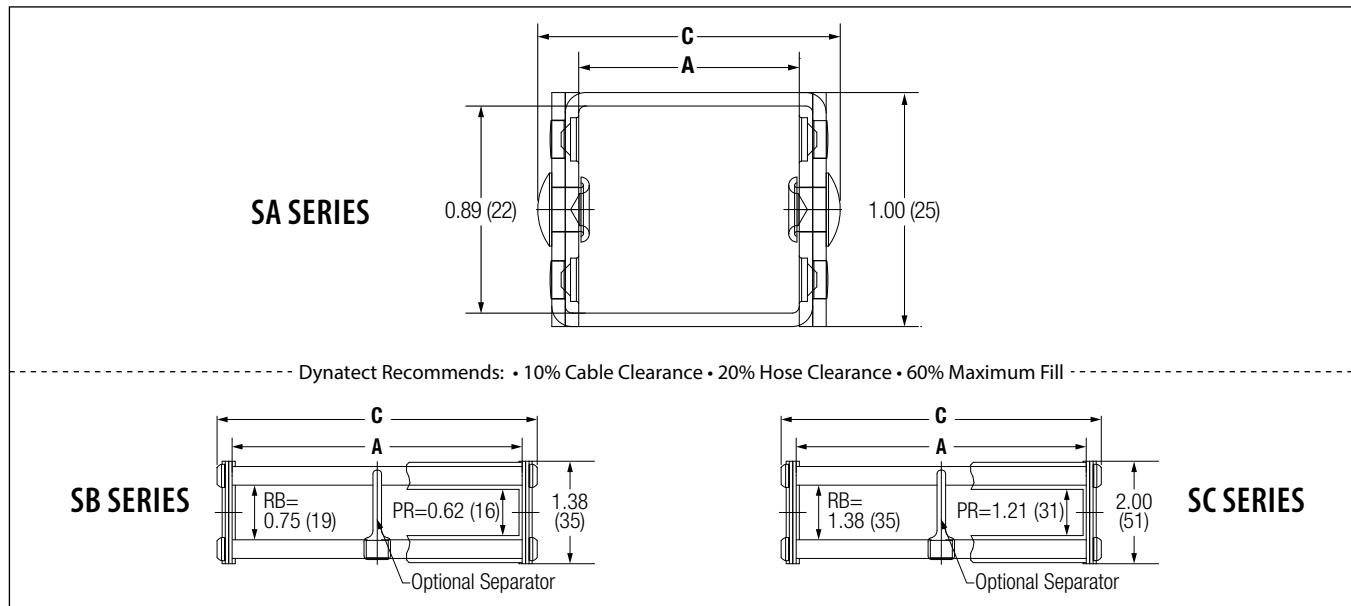

MRC / GX SERIES | GORTRAC® STEEL (open-style carriers)

MRC SERIES



Features:

- Standard construction: zinc-dichromate plated steel sidebands with round aluminum crossbars
- Patented half shear lockout link system simplifies construction by reducing parts
- Unlimited cavity width flexibility
- Non-essential center portions of the link that are not exposed to strain have been removed to further reduce weight

Crossbar Options:

- Bolted aluminum flat bar
- PVC poly rollers
- Easy-out aluminum round bar

Quick Sizing Reference – inches (mm):

- Link Height: 2.00 (51)
- Link Pitch: 3.00 (76)
- Curve Heights ('H'): 7.50 – 17.00 (191 – 432)

GX SERIES



Features:

- Standard construction: zinc-dichromate plated steel link with double locking points and integral flat crossbars alternating top/bottom every other link
- Unique, one-piece link design results in surprisingly lightweight carrier
- Integral flat crossbars provide added strength
- Priced competitively with plastic systems but significantly stronger and longer unsupported span

- Patented half shear lockout system simplifies construction and reduces parts

Crossbar Options:

- Bolted aluminum round bars
- PVC poly rollers

Quick Sizing Reference – inches (mm):

- Link Height: 2.00 (51)
- Link Pitch: 2.50 (64)
- Curve Heights ('H'): 6.00 – 13.25 (152 – 337)

MRC SERIES SPECIFICATIONS

MODEL NO.	A inches (mm)	C inches (mm)	WEIGHT lb/ft (kg/m)
MRC	Customer Specified	A + 0.62 (16)	2.95 (4.39)

GX SERIES SPECIFICATIONS

MODEL NO.	A inches (mm)	C inches (mm)	WEIGHT lb/ft (kg/m)
GX225	2.25 (57)	2.69 (68)	1.80 (2.68)
GX300	3.00 (76)	3.44 (87)	1.90 (2.83)
GX450	4.50 (114)	4.94 (125)	2.00 (2.98)
GX550	5.50 (140)	5.94 (151)	2.10 (3.12)
GX700	7.00 (178)	7.44 (189)	2.20 (3.27)

Crossbar Styles:

- FB = Alternating Link Flat Bar
- RB = Bolted Aluminum Round Bar
- PR = Poly Roller over Bolted Aluminum Round Bar
- AF = Bolted Aluminum Flat Bar

CARRIER CROSS SECTION – Dimensions in inches (mm)

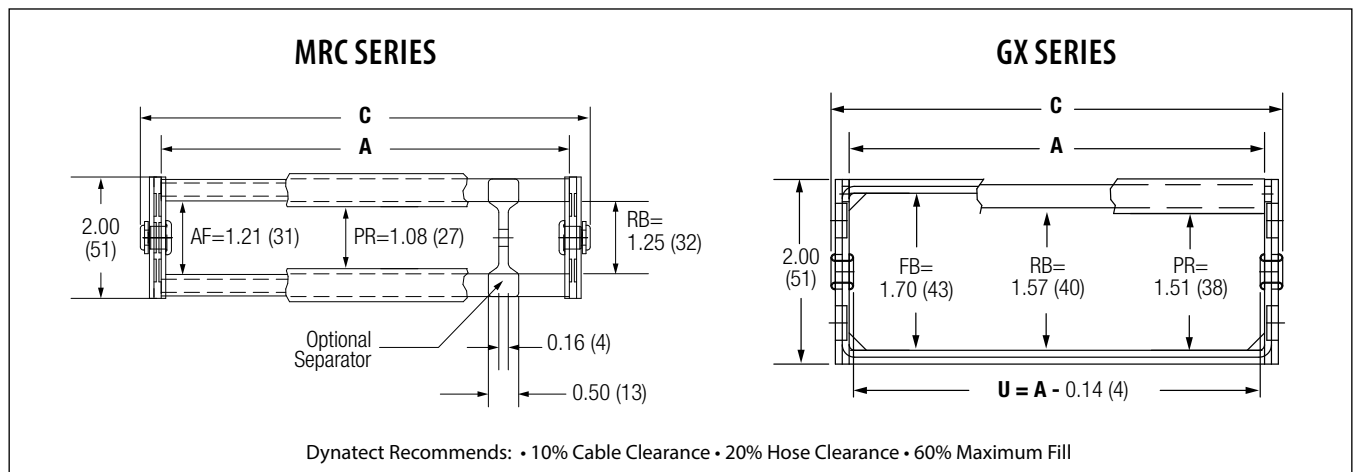

SX / SRC / LRC SERIES | GORTRAC® STEEL (open-style carriers)



SX SERIES

Features:

- Standard construction: zinc-dichromate plated steel sidebands with two locking points and round aluminum crossbars
- Self-cleaning link design expels debris from critical areas of the link during operation
- Unlimited cavity width flexibility

Crossbar Options:

- Bolted aluminum flat bar
- Snap-in aluminum flat bar
- PVC poly rollers
- Easy-out aluminum round bar

Quick Sizing Reference – inches (mm):

- Link Height: 3.20 (81)
- Link Pitch: 4.00 (102)
- Curve Heights ('H'): 10.13 – 27.31 (257 – 694)



SRC/LRC SERIES

Features:

- Standard construction: zinc-dichromate plated steel sidebands with flat aluminum crossbars
- Custom option: stainless steel
- Patented half shear lockout link system simplifies construction by reducing parts
- Unlimited cavity width flexibility
- Non-essential center portions of the link that are not exposed to strain have been removed to further reduce weight
- Available as enclosed-style carrier with bolted aluminum armor plates (side bands are provided without openings)

- PVC Poly rollers
- Easy-out aluminum round bar
- Custom-machined cable/hose bar

Lid Option:

- Bolted aluminum armor plate

Quick Sizing Reference – inches (mm):

- **SRC Series**
- Link Height: 3.00 (76)
- Link Pitch: 4.00 (102)
- Curve Heights ('H'): 11.00 – 27.50 (279 – 699)

Quick Sizing Reference – inches (mm):

- **LRC Series**
- Link Height: 4.00 (102)
- Link Pitch: 5.00 (127)
- Curve Heights ('H'): 15.00 – 52.50 (381 – 1334)



SX SERIES SPECIFICATIONS

MODEL NO.	A inches (mm)	C inches (mm)	U (USABLE WIDTH) inches (mm)	WEIGHT lb/ft (kg/m)
SX	Customer Specified	A + 0.58 (15)	A - 0.47 (12)	4.6 (6.85)

SRC/LRC SERIES SPECIFICATIONS

MODEL NO.	A inches (mm)	C inches (mm)	U (USABLE WIDTH) inches (mm)	WEIGHT lb/ft (kg/m)
SRC	Customer Specified	A + 0.69 (17)	A - 0.28 (7)	5.00 (7.44)
LRC	Customer Specified	A + 0.69 (17)	A - 0.40 (10)	6.00 (8.93)

Crossbar Styles:

AF = Bolted Aluminum Flat Bar AFS = Snap-In Aluminum Flat Bar
 RB = Bolted Aluminum Round Bar PR = Poly Roller over Bolted Aluminum Round Bar MC = Machined Carrier Bar (Custom)
 AP = Bolted Aluminum Armor Plate (Enclosed-Style Carrier)

CARRIER CROSS SECTION – Dimensions in inches (mm)

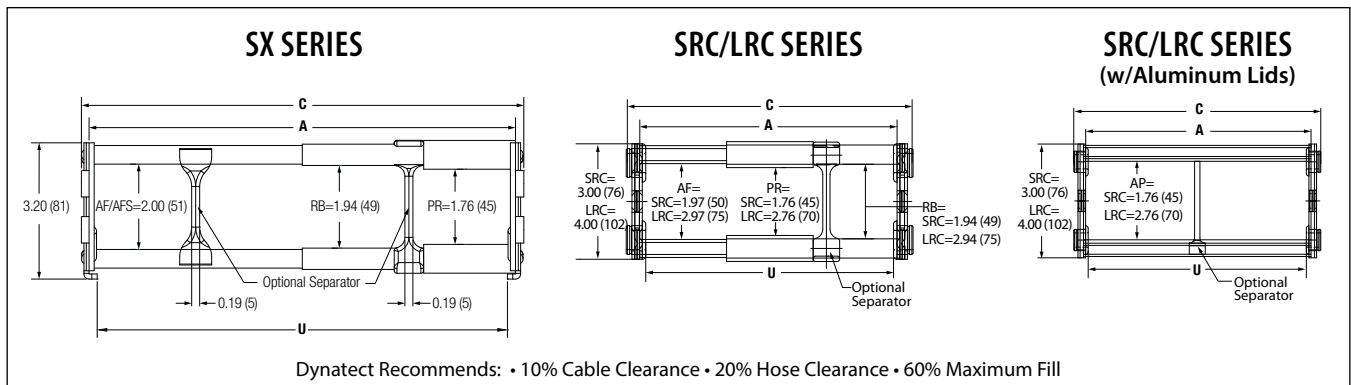

Dynatect Recommends: • 10% Cable Clearance • 20% Hose Clearance • 60% Maximum Fill

XX / XL SERIES | GORTRAC® STEEL (open- & enclosed- style carriers)



XX SERIES **NEW!**

Features:

- Standard construction: zinc-dichromate plated steel sidebands with 3 locking points and round aluminum crossbars
- Self-cleaning link design expels debris from critical areas of the link during operation
- Unlimited cavity width flexibility

Crossbar Options:

- Bolted aluminum round bar

- Bolted aluminum flat bar
- PVC Poly rollers
- Custom-machined cable/hose bar
- Custom formed steel channel flat bar

Quick Sizing Reference – inches (mm):

- Link Height: 6.00 (152)
- Link Pitch: 7.38 (187)
- Curve Heights ('H'): 26.00 – 60.00 (660 – 1524)



XL SERIES

Features:

- Standard construction: zinc-dichromate plated steel sidebands with 4 locking points and round aluminum crossbars
- Custom option: stainless steel; heavy "mill-duty" construction
- Unlimited cavity width flexibility
- Available as enclosed-style carrier with bolted aluminum armor plates (XL6)

Crossbar Options:

- Bolted aluminum round bar
- Bolted aluminum flat bar
- PVC Poly rollers
- Custom machined cable/hose bar
- Custom formed steel channel flat bar

Lid Option (XL6 Models):

- Bolted aluminum armor plate

Quick Sizing Reference – inches (mm):

XL6

- Link Height: 5.91 (150)
- Link Pitch: 7.38 (188)
- Curve Heights ('H'): 26.00 – 65.00 (660 – 1651)

Quick Sizing Reference – inches (mm):

XL8

- Link Height: 7.87 (200)
- Link Pitch: 9.33 (237)
- Curve Heights ('H'): 29.00 – 80.00 (737 – 2032)

Quick Sizing Reference – inches (mm):

XL10

- Link Height: 9.84 (250)
- Link Pitch: 11.67 (296)
- Curve Heights ('H'): 48.00 – 80.00 (1219 – 2032)

XX SERIES SPECIFICATIONS

MODEL NO.	A inches (mm)	C inches (mm)	U (USABLE CAVITY WIDTH) inches (mm)	WEIGHT lb/ft (kg/m)
XX6	Customer Specified	A + 0.81 (21)	A - 0.38 (10)	13.00 (19.35)

XL SERIES SPECIFICATIONS

MODEL NO.	A inches (mm)	C inches (mm)	U (USABLE WIDTH) inches (mm)	WEIGHT lb/ft (kg/m)
XL6	Customer Specified	A + 1.25 (32)	A - 0.51 (13)	20.00 (29.76)
XL8	Customer Specified	A + 1.25 (32)	A - 0.51 (13)	28.00 (41.666)
XL10	Customer Specified	A + 1.25 (32)	A - 0.51 (13)	32.00 (47.62)

Crossbar Styles:

AF = Bolted Aluminum Flat Bar RB = Bolted Aluminum Round Bar PR = Poly Roller over Bolted Aluminum Round Bar
 MC = Machined Carrier Bar (Custom) FC = Formed Channel Bar (Custom) AP = Bolted Aluminum Armor Plate (Enclosed-Style Carrier)

XX / XL SERIES | GORTRAC® STEEL (open- & enclosed- style carriers)

CARRIER CROSS SECTION – Dimensions in inches (mm)

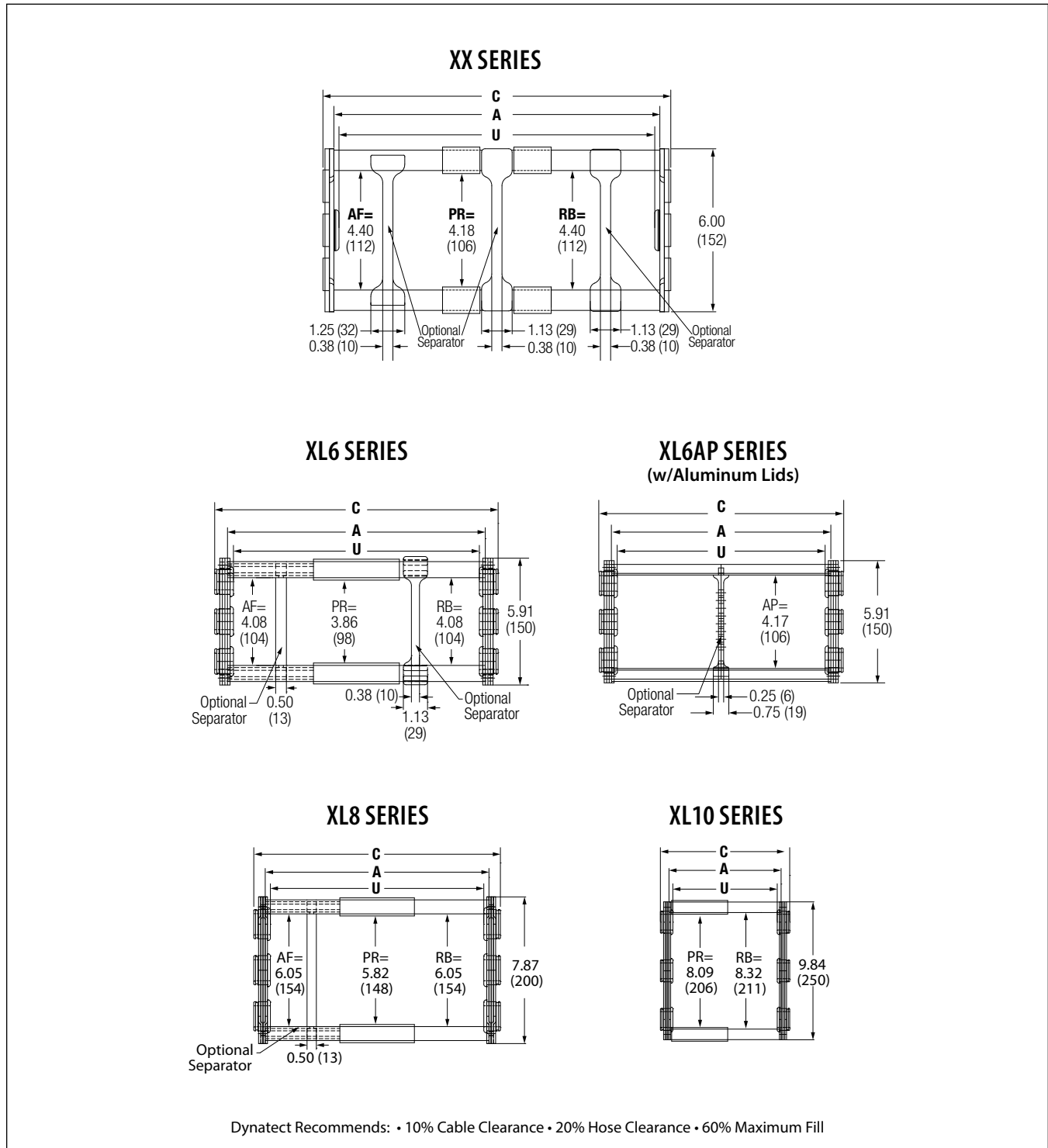

GORTUBE® SERIES | STEEL (enclosed-style carriers)



Features:

- Conduit-style galvanized steel tube fully encloses cables/hoses to resist hot chips, swarf, cutting oils and lubricants
- Smooth, low-noise operation; suitable for fast speeds and accelerations

- Construction options for high temperature, corrosive environments, or multi-axis and rotational applications
- Optional black oxide finish
- Wide range of sizes – 24 different size/radius combinations

SPECIFICATIONS

MODEL NO.	A inches (mm)	B inches (mm)	C inches (mm)	D inches (mm)	WEIGHT lb/ft (kg/m)
C0	1.02 (26)	0.63 (16)	1.18 (30)	0.79 (20)	0.40 (0.60)
C1	1.79 (45)	1.00 (25)	1.97 (50)	1.18 (30)	0.90 (1.34)
C1A	1.79 (45)	1.79 (45)	1.97 (50)	1.97 (50)	0.90 (1.34)
C1B	1.98 (50)	1.59 (40)	2.17 (55)	1.77 (45)	0.90 (1.34)
C2	2.97 (75)	1.59 (40)	3.15 (80)	1.77 (45)	1.50 (2.23)
C2C	3.17 (81)	1.59 (40)	3.35 (85)	1.77 (45)	1.70 (2.53)
C2A	3.56 (90)	1.79 (45)	3.74 (95)	1.97 (50)	2.10 (3.12)
C2AA	3.17 (81)	2.19 (56)	3.35 (85)	2.36 (60)	2.10 (3.12)
C3	4.11 (104)	2.15 (55)	4.33 (110)	2.36 (60)	2.40 (3.57)
C3A	4.29 (109)	2.93 (74)	4.53 (115)	3.15 (80)	2.40 (3.57)
C3AA	4.31 (109)	2.15 (55)	4.53 (115)	2.36 (60)	2.80 (4.17)
C3C	5.26 (134)	3.29 (84)	5.51 (140)	3.54 (90)	3.50 (5.21)
C4	6.48 (165)	2.93 (74)	6.69 (170)	3.15 (80)	3.80 (5.65)
C5	6.42 (163)	3.50 (89)	6.69 (70)	3.74 (95)	4.00 (5.95)
C6	7.68 (195)	3.71 (94)	7.87 (200)	3.94 (100)	4.10 (6.10)
C7	8.43 (214)	4.09 (104)	8.66 (220)	4.33 (110)	4.60 (6.84)

CARRIER CROSS SECTION – Dimensions in inches (mm)

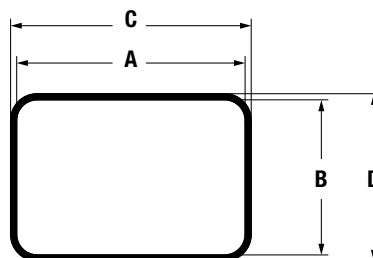

Dynatect Recommends: • 10% Cable Clearance • 20% Hose Clearance • 60% Maximum Fill

LSI PRECISION GROUND BALL SCREWS

Why settle for a standard design, when the experts at LSI can create a linear motion component precisely matched to your specifications. Your choices are not limited to a few ball screw and nut designs in a catalog. Send us your old screw, print, or specifications; or contact your local sales rep to discuss your application.

FULL SERVICE REPAIR AND REVERSE ENGINEERING SERVICES

Our expert technicians can repair or rebuild your ball screw, acme screw, lead screw or specialty threads to save you money and extend the life of your old screw before a costly replacement becomes necessary.

DESIGN FEATURES

A ball screw offers greater energy efficiency than acme screws, converting nearly all input torque to thrust. In addition to lower energy consumption, a ball screw offers greater precision, predictability of life and long-term preload.

LSI precision ground ball screws offer distinct advantages over competitive offerings:

High Precision

Ball screws manufactured up to ANSI Class 2 or DIN/JIS Class 1 specification.

Large Diameter Up to 6 Inches

Screw diameters from 1/2" to 6" (16mm to 150mm). Larger diameters may be available upon request.

Long Screw Lengths

Available in virtually any length. (Our longest ball screw is 54 feet in length.)

"Zero Lost Motion" Solutions

We customize your design to minimize backlash and eliminate deadband.

Internal Ball Return Design*

Our internal ball return design gives you the following benefits:

- **Optimal life** – balls travel in paths that are tangent to the pitch, resulting in longer life and reduced speed
- **Higher operating speeds** – travel path increases permissible speed
- **Smooth operation and low noise** – balls spend less time traveling unloaded
- **Cost-effective design** – a single component which allows for smallest overall package sizes
- **Ease of installation** – components protected by design means low risk of damage during installation



Customization

Your ball screw will be configured with the options you specify, and can be further customized for a complete turn-key solution that is quick and easy to install, saving you time and money.

- Ball nut configuration (single or double nut, 2-piece flange to flange nut, middle flange nut)
- Internal or external ball returns
- Wipers and end seals
- Custom journal ends
- Custom housing and mounting blocks

*External tube ball return designs can be provided to accommodate shorter length nut designs and multi-start screws can be provided for long lead – high capacity applications.

LSI CAPABILITIES | BALL SCREW DIAMETER AND LEADS

The combinations of ball screw diameter and lead shown below are most common to LSI capabilities. Sizes are offered in both imperial and metric sizes. Additional screw diameters, leads, and combinations are available, including multiple start screws. Please contact Dynatect LSI to evaluate your specific needs.

NORMAL SCREW DIAMETER (inches)	LEAD (inch)										
	0.100	0.125	0.158	0.200	0.250	0.375	0.400	0.500	0.625	0.750	1.000
0.625											
0.750											
0.875											
1.000											
1.125											
1.250											
1.500											
1.625											
1.750											
2.000											
2.250											
2.500											
2.750											
3.000											
3.500											
4.000											
6.000											

NORMAL SCREW DIAMETER (mm)	LEAD (mm)										
	3	4	5	6	8	10	16	18	20	25	40
12											
16											
20											
25											
32											
40											
50											
63											
80											
100											
125											
150											

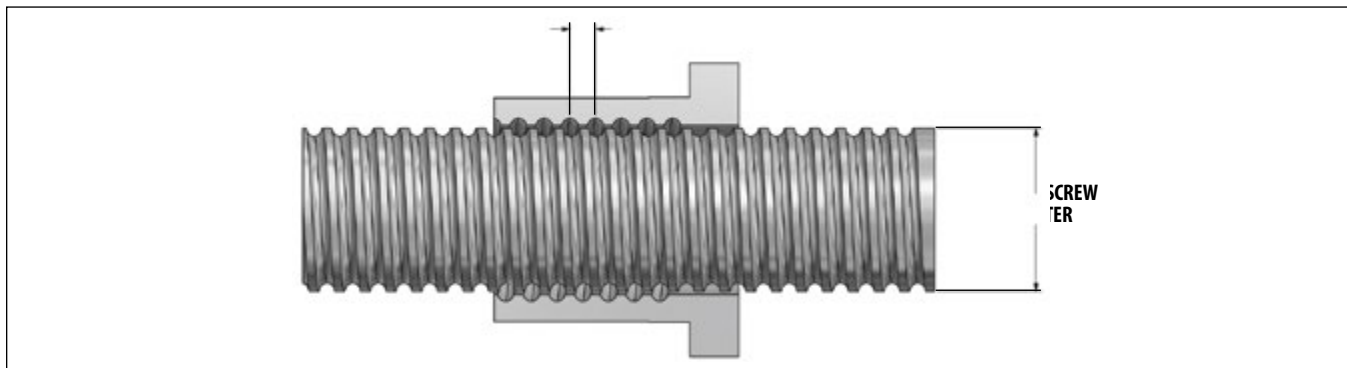

POLYCLUTCH® CONTINUOUS SLIP CLUTCHES

POLYCLUTCH ELIMINATES STICTION – Polyclutch has developed a unique technology and manufacturing process resulting in static friction being lower than dynamic friction. This characteristic generates repeatable torque control and smooth operation while slipping.

- No sudden shock on sensitive paper, film, wire, thread, etc.
- Repeatable cushioned torque for protection during overload
- Ideal for friction hinges when smooth movement of lids, doors, screens, covers, etc., is required

- Smooth, accurate starting/stopping of conveyors, indexing mechanisms, linear actuators, etc.
- Repeatable accurate torque for capping machines, automatic screw driving, valve control, etc.

Our proprietary burn-in process ensures that all Polyclutch Slip Clutches will perform consistently right out of the box, with no break-in period required.

APPLICATIONS:

- Overload Protection (machine and personnel safety)
- Torque Control (bottle capping, fastener driving)
- Tension Control (printing, stamping, labeling and take-up reels)
- Positioning Hinge (covers, medical equipment, light fixtures)

KEY BENEFITS:

- Smooth breakaway and continuous slip
- Long life of 20 to 30 million cycles in slip condition
- Torque range from 0.5 lb-in to 750 lb-in
- Fixed, adjustable and custom designs
- Clutches are bi-directional
- No lubrication needed
- Made in the USA

A GREAT ALTERNATIVE TO:

- Servo-motors: our solution costs less
- Magnetic clutches: smaller, less expensive
- Ball detent: no clicking, no reset required
- Torque limiters: consistent repeatability, continuous slip
- Electronic protection only: added mechanical safety in electronically controlled systems

LIMITATIONS:

- Maximum 1.25-inch shaft size
- Not to be used as a universal joint or a spring coupler
- Does not de-couple at overload
- Cannot be exposed to radiation
- Contact a Polyclutch application specialist if slip clutch would be directly exposed to weather or wash down

CONTINUOUS SLIP CLUTCHES SOLVE MANY DESIGN ENGINEERING PROBLEMS:

Polyclutch slip clutches can slip continuously or intermittently for over 30 million cycles. This opens up many design engineering options including...

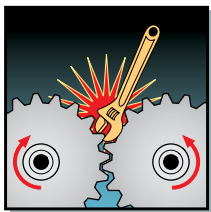

Overload Protection

Protect machinery and operator. Clutch will slip when mechanism is jammed. Motion will

continue when impediment is removed.

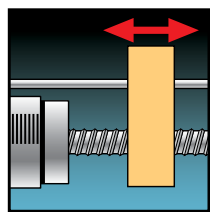

Soft Starts/ Cushioned Stops

Inertia makes clutch slip when starting and/or stopping. Results in less shock throughout the

system. Ideal for slip at the end of stroke.

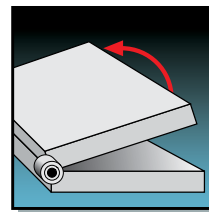

Positioning Hinge

Hold lid, cover, door, light fixture, screen, etc., at any position. Fingertip control. Combine with one way

clutch for free movement in one direction.

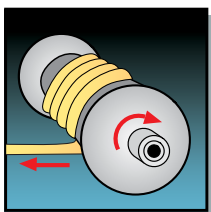

Tension Control

Maintain constant tension while winding or unwinding wire, paper, film, thread, etc. Slip clutch automatically

compensates for changes in speed and diameter. Pneumatic clutch can change tension during operation.

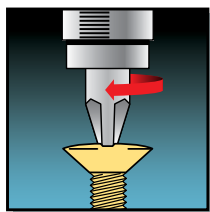

Torque Control

Screw bottle caps, screws, controls, etc., to correct torque setting. Combine with one way clutch to slip

at rated torque in one direction and freewheel or positive drive in other direction.

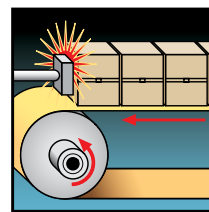

Force Control

Push product against gate with constant force. Remove gate and move to next position. No damage to product





or conveyor – clutch does all the slipping. Also used for overload protection when jammed and for indexing the conveyor.

SLIP CLUTCH LINE OVERVIEW

HOW TO DETERMINE THE PERFECT CLUTCH FOR YOUR APPLICATION

Three factors in determining the right clutch are: the maximum shaft size, torque capacity of the clutch, and wattage capacity. Maximum wattage capacities are listed for each model in the Series specifications. Please consider the maximum torque capacities when making your selection.

Note: For torque adjustment while clutch is in use (remote torque adjustment), see the SLIP-AIRE clutches.

Slip Clutch	Max. Shaft Size	Torque Capacities Up To (lb-in)					Unique Features
		10	100	150	300	500	
 SERIES 16 (MECHANICAL)	Up to 3/8" dia.	→					<ul style="list-style-type: none"> • Very cost-effective for low torque needs up to 10 lb-in • Compact, small package (1 inch outer diameter)
 SLIPPER (MECHANICAL)	Up to 1" dia.	→					<ul style="list-style-type: none"> • Standard-duty mid-size clutch • Economical for low torque but larger shaft applications
 V-SERIES SLIPPER (MECHANICAL)	Up to 1" dia.	→					<ul style="list-style-type: none"> • Self-supporting design eliminates need for through-shaft, allows vertical installation • Integrated ball bearing allows thrust loads up to 650 lbs. without any effect on torque • Easy to install in vertical and horizontal applications without driveshaft modification
 SLIP-EASE (MECHANICAL)	Up to 1" dia.	→					<ul style="list-style-type: none"> • Smallest and largest available models • Low backlash design • Smallest O.D. to torque ratio
 SLIP-AIRE (PNEUMATIC)	Up to 5/8" dia.	→					<ul style="list-style-type: none"> • Based on mechanical slipper design: pneumatic piston replaces adjustment nut • Applications: adjustment while machine is running or from a remote location

APPLICATION EXAMPLES



Polyclutch® Extends Machinery Life

Polyclutch adjustable slip clutches control the precise amount of torque to tighten bottle caps, without wear or breakage, in this capping line application. All the slippage is in the clutch, with no appreciable wear.

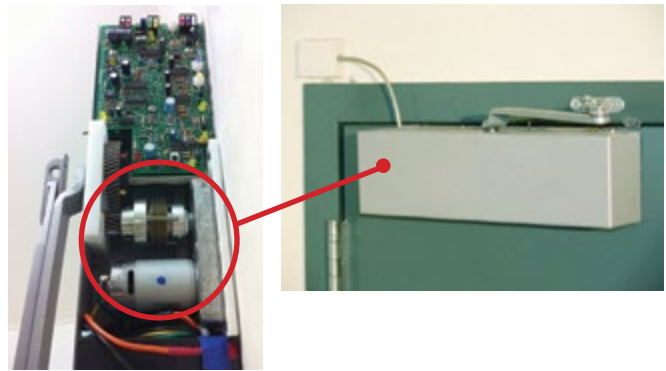

Disabled Access Systems

A Polyclutch slip clutch provides safety in many disabled access systems, as seen in this photo, where it is being used for overload protection in an automated door opener.



Ice-Dispensing Machines

Hidden deep inside of this ice-making machine, a Polyclutch slip clutch prevents overload to the drive mechanism during the forming and dispensing of ice cubes.



Retail Vending Kiosks

A Polyclutch protects this machine against any type of overload or jamming during the process of dispensing a DVD.

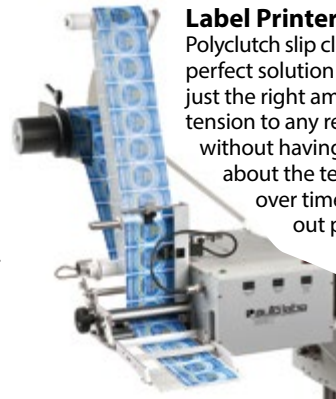

Label Printers

Polyclutch slip clutches are the perfect solution for adding just the right amount of tension to any reel or spool without having to worry about the tension varying over time or wearing out prematurely.

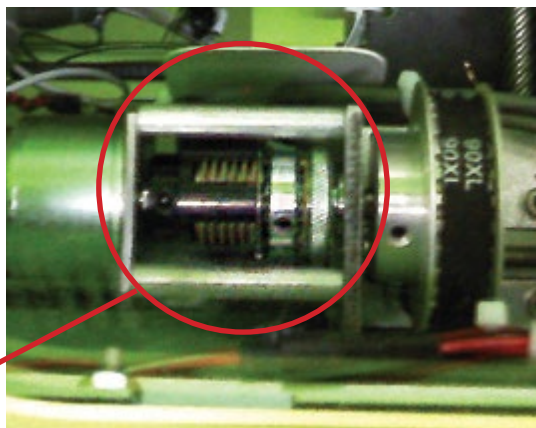
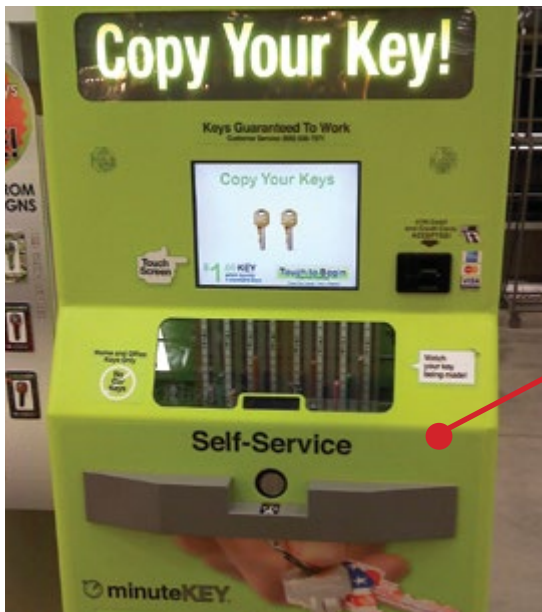

Automated Kiosks

Polyclutch slip clutches are an integral part of many retail kiosks. As shown in this photo, a slip clutch is used to protect the sensitive drive mechanisms of these automated machines.

APPLICATION EXAMPLES



MRI Beds

Polyclutch® adds a mechanical safety for moving MRI beds as seen in this picture.



Military and Law Enforcement Inspection Robots

The Machine Lab, Inc., an industry leader in defense robotics, uses two Polyclutch slip clutches in each robot arm for overload protection.

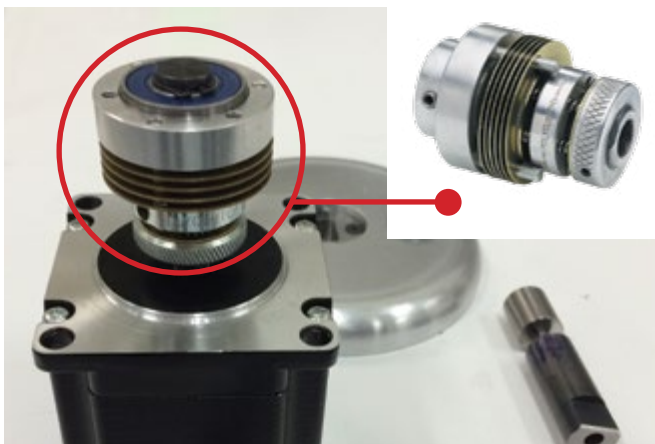

The Polyclutch slipper provides precision torque control during the manufacturing of dental implants.

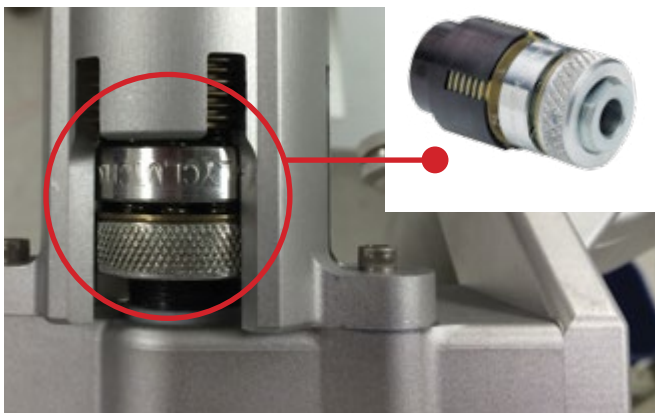
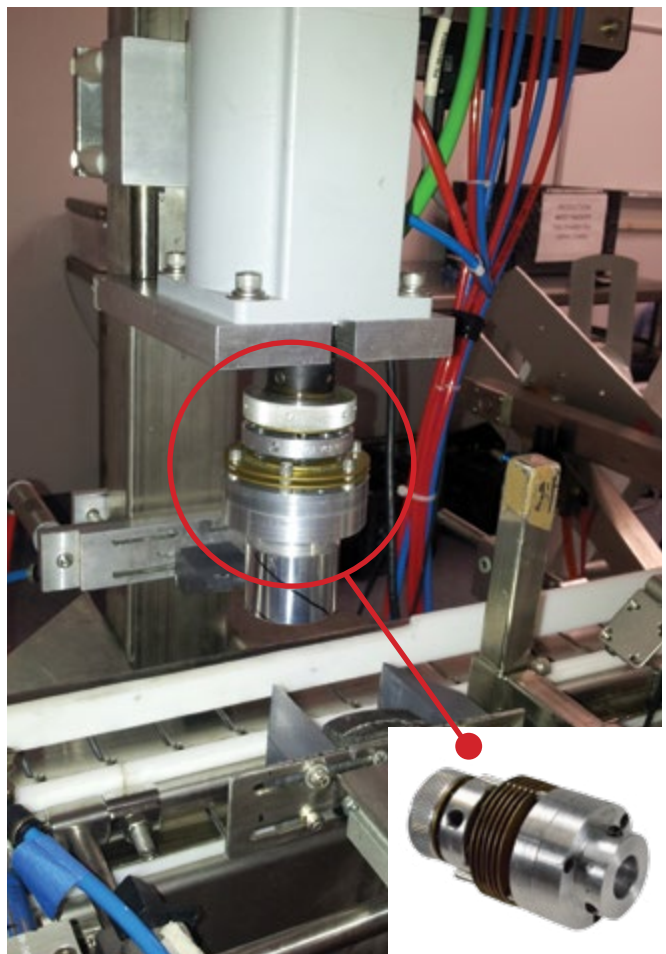

In this medical application, a Slip-Ease clutch is used as a retention hinge on a mounting platform of a surgical device.

The V-Series slipper is the ideal solution for torque control on capping machines.

RO-LAB CUSTOM MOLDING | RUBBER AND POLYURETHANE

DYNATECT RO-LAB CUSTOM MOLDED RUBBER AND URETHANE PRODUCTS

Dynatect Ro-Lab is a leading specialist in compounding and producing custom rubber and urethane products with over 100 years of combined elastomer experience, in-house quality control and testing. Our expertise in production and process selection helps us deliver a well-designed and functional product.

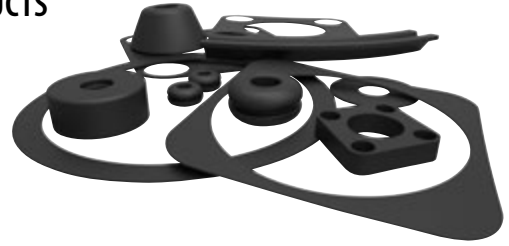

Molding Capabilities

- Rubber molding (compression, injection, transfer)
- Urethane molding (compression, RIM, low pressure injection, open cast)
- Mandrel-formed products (hoses, industrial and agricultural rolls, rubber-lined pipes, continuous lengths of tubing and belts)

Specialties

- Small sized, high-volume parts
- Large-scale parts
- Insert molding (functional metal, textiles or ceramic inserts molded into rubber or polyurethane)
- Custom material formulation (to meet performance specifications for durability, flexibility and elasticity)
- Precise tolerances and special finishes

TOTAL PRODUCTION CONTROL FROM CONCEPT THROUGH MANUFACTURING... ALL UNDER ONE ROOF

The toughest challenges in rubber and polyurethane routinely come to Dynatect Ro-Lab, thanks to a complete in-house capability that stretches from design consulting and custom material formulation to precision molding, finishing and beyond. Generations of OEM manufacturers have trusted Dynatect Ro-Lab to expand the range of possibilities in rubber and urethane components:

- **Tighter tolerances** – stricter adherence to dimensional standards in molding – including RMA A1
- **Custom material formation** – creation of custom polymer blends to conform precisely to customer requirements
- **Exceptional size and thickness** – components that are extra large or extremely small, very thin or extraordinarily thick
- **Insert molding and special finishes** – adding insert components to meet special mechanical requirements, or conforming appearance to RMA F1... the highest standard for exterior attractiveness

Dynatect Ro-Lab capability expands to improve every part of the component life cycle. It begins with the design collaboration between Dynatect Ro-Lab molding specialists and custom engineers. The capability continues with the first article inspections, dimensional validation and part traceability.

Let us show you how we bring extra flexibility into the manufacturing of custom components. Contact us at 800-298-2066, or email to sales@dynatect.com.

MORE PRESSES, MORE PROCESSES FOR GREATER MOLDING OPTIONS

Press Capacity for Large Components, High Volumes

The Dynatect Ro-Lab commitment is supported by an inventory of 100 rubber and urethane presses, with capacities ranging from 5 to 2,500 tons.

Rubber Molding

- 75+ presses, 40 - 2,500 ton capacity
- Presses up to 80" wide
- Platen sizes up to 20' long
- Internal mixing for custom compound production

Urethane Molding

- 23 presses with capacities from 5 - 250 tons
- Up to 24" x 24" platen size
- Machine mixing to 40 lbs/min.
- Oven capacities to 2,880 cubic feet (20' x 12' x 12')



RO-LAB CUSTOM MOLDING | RUBBER AND POLYURETHANE

RUBBER MOLDING

Compression Molding

A straightforward elastomeric molding method involving placement of raw rubber into a two-part heated mold, followed by compression of the rubber in the mold to form and cure the thermoset material under heat and pressure.

- Dynatect Ro-Lab's 1,400 ton compression press is ideal for large molds or thin sheets with close tolerances
- Multi-cavity molds can produce parts down to two grams
- Continuous curing for long, uninterrupted items
- A preferred process for gaskets, seals and O-rings

Transfer Molding

In a process that is a hybrid of compression and injection techniques,

a piston forces preheated material from a transfer pot into a closed mold.

- Creates finished components with intricate shapes
- Compatible with the use of delicate inserts
- Delivers tight dimensions and tolerances
- Usable for all rubber durometers

Injection Molding

A more complex process that injects a preheated material into the cavities of a closed mold.

- Delivers faster curing times than compression or transfer molding
- Shortens cycle times
- Ideal for high volume component production



HOT CAST URETHANE MOLDING

Compression Molding

Liquid polyurethane is poured into a mold and cured in a compression press with capacities up to 250 tons. This technique is most suitable for components that must maintain dimensional accuracy and repeatability.

Low Pressure Injection Molding

Injection of liquid polyurethane into a closed mold under low pressure, in a process ideal for projects in which a component size, component shape

or tooling configuration would make compression molding practical.

Open Cast Molding

The pouring of liquid polyurethane into an open mold, which is then cured in an oven or on a heated table.

- Usable on part sizes from less than an ounce to more than 500 lbs.
- Excellent for projects where conventional tooling would be expensive or impractical



SPECIAL PROCESS

Hoses

- Hoses are built on a mandrel (cylindrical form) in a variety of configurations
 - Soft or wire reinforced walls
 - Plain ends, or duck and rubber flanges with back-up rings
 - Built-in nipples

Other Mandrel-Made Products

- Non-hose mandrel-made products with 4" - 60" diameters with lengths to 50'
- Rubber transition chutes
- Mandrel-made endless belts

Rubber-Lined Pipes

Industrial and Agricultural Rolls

- Rubber or urethane covers
- New or stripped/recovered cores
- Roll regrinding
- Crowns and grooves

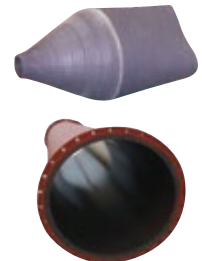

RIM (REACTION INJECTION MOLDING)

Injection of polyols and isocyanates into a closed mold, triggering a chemical reaction that causes the material to expand and form the finished product.

- Effective in forming extremely large products with very light weights

- Able to improve or eliminate secondary operations
- Workable for flexible or rigid products in foams or solids
- Delivers reliable control of components with varying wall thickness

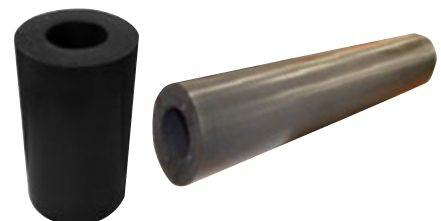

DYNATECT™

DYNAMIC EQUIPMENT PROTECTION

Global Leaders in Dynamic Protection
for Equipment and People

CONNECT

GLOBAL HEADQUARTERS

2300 South Calhoun Road
New Berlin, WI 53151

phone: +1 262 786-1500

fax: +1 262 786-3280

email: sales@dynatect.com

DYNATECT.COM