

NOTES:

- 101 APPLY O-RING LUBE TO SEAL BEFORE INSTALLATION.
- 102 APPLY ITEM 11 (LOCTITE, TYPE 242) TO EXTERNAL THREADS PRIOR TO ASSEMBLY.
- 103 TORQUE TO 18 IN.-LBS.

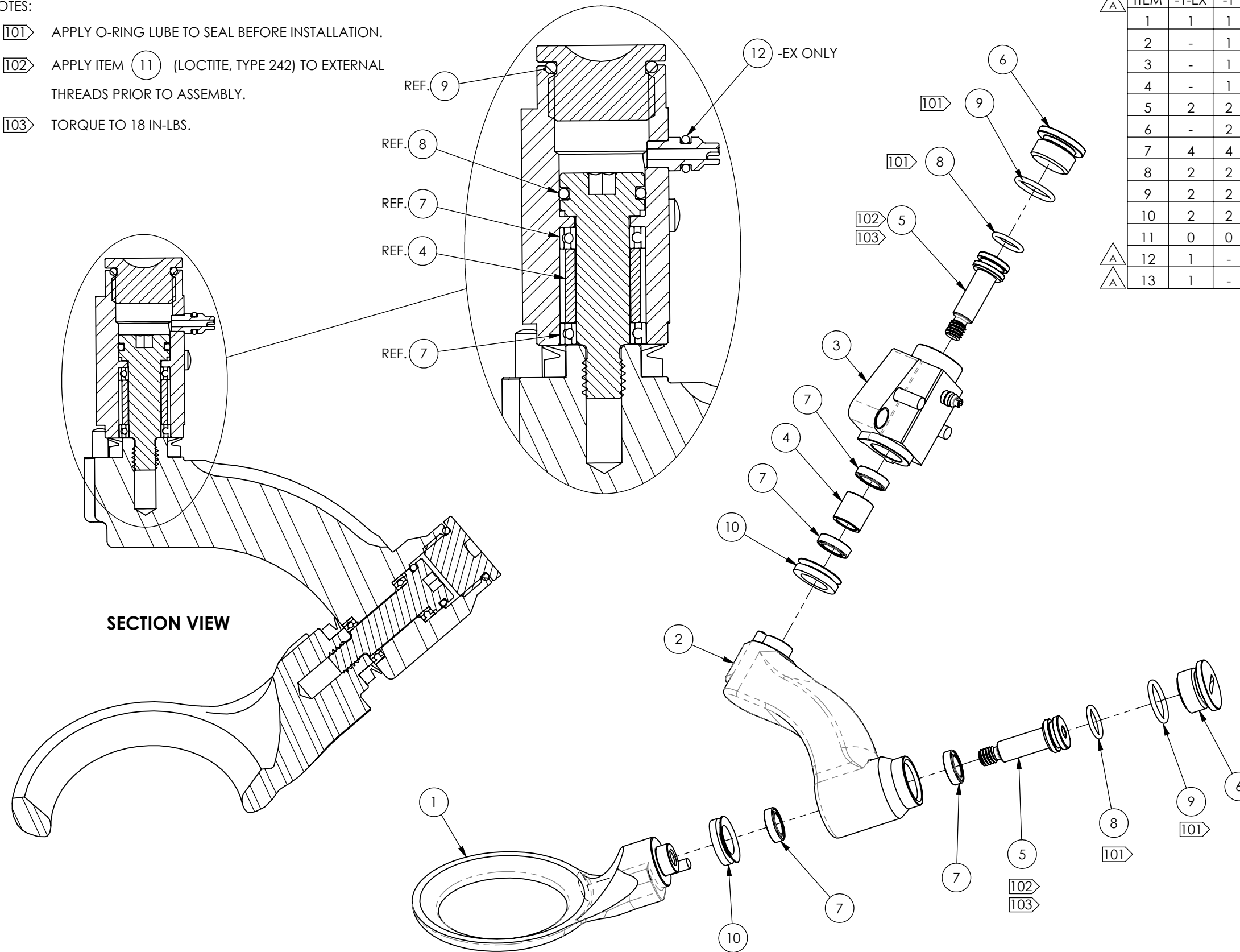

ITEM	-1-EX	-1	U/M	PART NUMBER	DESCRIPTION
1	1	1	EA	058120-1	TOUCH RING ASSEMBLY;COMPASS
2	-	1	EA	058117-1	ARM ASSEMBLY;SWIVEL;COMPASS
3	-	1	EA	058115-1	HOUSING ASSY;TOUCH RING SWIVEL;COMPASS
4	-	1	EA	058112-1	SPACER;BEARING;COMPASS;6.9MM LG
5	2	2	EA	058237-1	BOLT;SHLDR;MOD;FOOT ASSY;COMPASS
6	-	2	EA	058111-1	END CAP;FOOT ASSY;COMPASS
7	4	4	EA	A-30996-1	BEARING;RADIAL;BALL;OPEN;SST;5MM ID
8	2	2	EA	A-30995-2	O-RING;NBR;70A;.1.0 X 6.2 MM ID
9	2	2	EA	A-30995-3	O-RING;NBR;70A;.1.1 X 8.0 MM ID
10	2	2	EA	A-30997-1	SEAL;SHAFT;WITH WIPER;BUNA-N;7MM ID
11	0	0	EA	A-3202	ADHESIVE;LOCTITE 242;THD LOCKING;BLU
12	1	-	EA	A-30995-1	O-RING;NBR;70A;0.74 X 1.95MM ID
13	1	-	EA	058121-1-R	CONTOUR RING ASSEMBLY;RETURNED

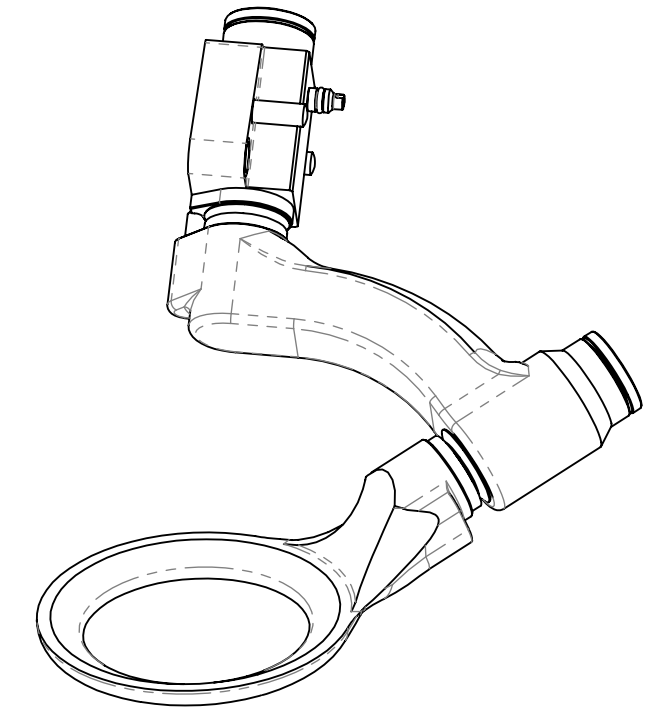

ENGINEERING REFERENCE	
PART NUMBER	DESCRIPTION
058121-1	CONTOUR RING ASSY, PRODUCTION
058121-1-R	CONTOUR RING ASSY, CUSTOMER RETURNED
058121-1-EX	CONTOUR RING ASSY, EXCHANGE

**(800) 991-4225**  
**www.ahbinc.com • customerservice@ahbinc.com**  
**ISO Certified**

THIRD ANGLE PROJECTION 			THIS DRAWING IS THE PROPERTY OF FLOW INTERNATIONAL CORPORATION AND IS NOT TO BE COPIED OR REPRODUCED WITHOUT THE WRITTEN CONSENT OF FLOW INTERNATIONAL CORPORATION.		
	MATERIAL SEE BOM				
DRAWN BY K. CLAEYS	STARTED 12/16/2014	ENG E. ROMANOFF	EST WEIGHT 0.17 KG	MODELED IN SOLIDWORKS	
TITLE CONTOUR RING ASSY;QD;COMPASS					
REVISION A	SCALE 1:1	BASE PART NUMBER	<b>058121</b>		1 OF 1