

 Flow

HYPERJET™ 94i-S & 94i-D

M-390 | REV. C | APRIL 2010



HYPERJET™ 94i-S AND 94i-D PUMPS

Due to continuing product improvement, the information contained in this document is subject to change without notice. Flow International Corporation shall not be held liable for technical or editorial omissions made herein, nor for any incidental or consequential damage resulting from the use of this material.

This document contains information protected by copyright. No part of this document shall be reproduced in any manner without prior written consent from Flow International Corporation.

HyperPressure™, HyperJet™ and WaterVeyor™ are trademarks of Flow International Corporation. Dynamic Waterjet®, HyPlex®, and Paser® ECL *Plus* are registered trademarks of Flow International Corporation.

© 2006–2010 Flow International Corporation. All rights reserved.

HyperJet™ 94i-S & 94i-D Pumps

Chapter 1. Equipment Description

- Features 7
- Specifications 8
 - Water requirements 9
 - Drain requirements 9
 - Water interface connections 10
- Pump startup sequence 11
- Operating an integrated HyperJet pump 12
 - Running the pump 12
 - Using dual pressure 12
- Running the HyperJet 94i-D on one motor 13
 - Changing pump operation mode 13
- Shipping or storing the intensifier pump 14

Chapter 2. Safety

- Safety precautions 15
- Warnings, cautions, and notes 15
- Safety tips 16
- Protective clothing 18
- Emergency medical information 19

Chapter 3. Operating the Standalone Pump

- Basics of pump control 21
 - Units 21
- Main control screens 22
 - Start screen 22
 - Main Run Screen 22
 - Change Pressure Setpoints 23
 - Dual Pressure Control 23
 - Boost Pump Control 24
- Pump Status screens 25
 - Pump Status 1 25
 - Pump Status 2 25
 - Analog Input Status 25
 - Pump shutdowns 26
 - Pump warnings 26
- Configuration screens 27
 - Configuration Screen 1 27
 - Configuration Screen 2 27
 - Configuration Screen 3 28
 - Configuring the clock 28
 - Defaults 29
 - Display Services 29

Chapter 4. Maintenance and Troubleshooting

- Periodic maintenance 31
 - Maintenance tips 31
 - Maintenance precautions 31
 - General precautions 31
 - Hydraulic oil 32
- Inspection and maintenance schedule 33
 - Every day 33
- Troubleshooting tips 34
- Weep holes 34
- Troubleshooting the high-pressure components 34
- Using the troubleshooting table 34
- Troubleshooting the intensifier pump 35
- Troubleshooting the pump using FlowSense 38
 - Warning conditions 38
 - Shutdown conditions 38
- Warning and shutdown conditions 39

Chapter 5. Servicing the pump

- Service tips 41
 - Service notes 42
- Torque specifications 42
- Servicing the hydraulic system
 - Hydraulic oil pump 43
 - Replacing the hydraulic pump 44
 - Cleaning a contaminated hydraulic system 46
 - Checking the hydraulic oil 48
 - Changing the hydraulic oil 49
 - Replacing the kidney loop oil filter 51
 - Servicing the heat exchanger 52
 - Servicing the bleed-down valve 53
 - Replacing the booster pump 55
 - Replacing the filter elements 56
- Servicing the shift valve manifold assembly 58
 - How it works 58
 - Replacing a complete intensifier assembly 59
 - Intensifier shift module 60
 - Pilot valve 62
 - Shift valve 64

Main system relief valve 66
 Replacing the main system relief valve 66

Shift sensor assembly 67
 How it works 67
 Service tips 67
 Replacing a shift sensor assembly 68

MS-2258, Maintenance Log

Chapter 5. Parts Lists

Pump drawings 69
Spares 70
Kits 70
Service kits 72
Tools 73
Label kits 73
Miscellaneous service parts 74

Chapter 6. Customer Support

MS-2266, Customer Support

Introduction

The information in this manual will help you become familiar with your new Flow International (FLOW) equipment. It was compiled from the most current information available at the time of publication and is intended to cover the most common configurations.

Safety

All operating personnel and service technicians must read and follow the procedures in this manual to avoid creating unsafe conditions, or risking damage to the equipment.

The comprehensive list of safety precautions in Chapter 2 of this manual must be followed to ensure safe operation of the equipment. These precautions must be reviewed and understood by operating and maintenance personnel before installing, operating, or servicing the equipment. The high-pressure waterjet system is a powerful cutting tool and must always be treated with respect.

Warnings, cautions, & notes

Before operating the equipment, please read, thoroughly understand, and follow all warnings, cautions, and notes that appear in this manual. They are defined as follows:

WARNING

Highlights an operating or service procedure or condition that can result in death or serious injury to personnel.

CAUTION

Highlights an operating or service procedure or condition that can lead to impaired system operation or equipment damage.

Note: Highlights an operating or service procedure or condition that is essential for efficient operation and service.

Notes

CHAPTER 1

Equipment Description

The HyperJet™ 94i-S & 94i-D Pumps are powerful, ultrahigh-pressure waterjet cutting tools.

Features

- The pumps have an *output* water pressure rating of 87,000 psi (6000 bar)
- UHP water system pressures are monitored by a pressure transducer and displayed in FlowCUT®
- Dual filter system removes particles larger than 0.5 microns absolute
- Controlled with FlowMaster® software
- FlowSense®, an early warning system for critical parts
- Available in two versions: a single-motor 50 hp (HyperJet 94i-S) or dual-motor 100 hp (HyperJet 94i-D)

HyperJet 94i-S

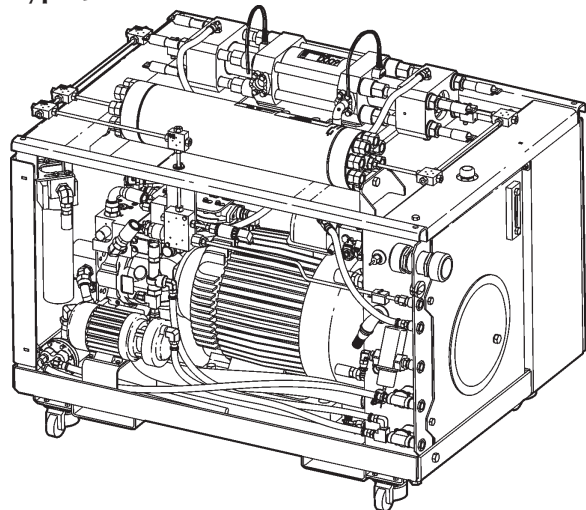

HyperJet 94i-D

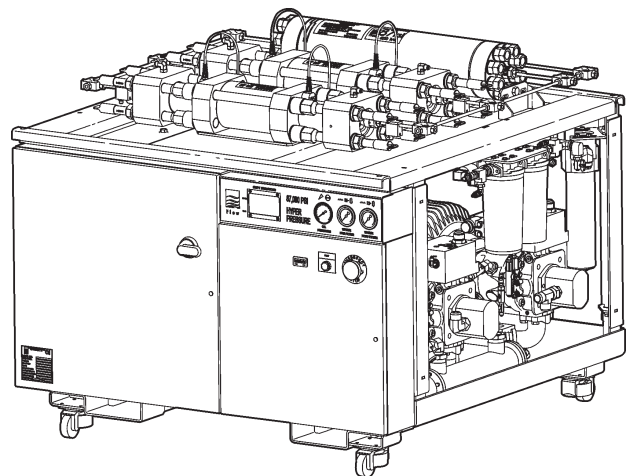

Specifications

Contact Flow Technical Service for further information. Also see the system drawings in Chapter 5.

Dimensions

HyperJet 94i-S 54 in. x 40 in. x 45 in.
HyperJet 94i-D 57.4 in. x 55.3 in. x 44.1 in.

Oil 240 SSU

Flow recommends the following oils, but other manufacturer's equivalents can be used:

Shell Turbo T 46
Chevron Turbine Oil GST 46
Mobil DTE Medium
Texaco Regal R&O 46

Reservoir

HyperJet 94i-S 25 gallons (95 liters)
HyperJet 94i-D 37 gallons (140 liters)

Output pressure 87,000 psi (6000 bar)

Filtration provided 0.5 micron and 1 micron

Cooling water in

HyperJet 94i-S 3 gpm @ 50 psi, 60°F or less
HyperJet 94i-D . . . 5 gpm min @ 50 psi, 60°F or less

Filtered water in

HyperJet 94i-S 1 gpm @ 30-35 psi, 80°F or less
HyperJet 94i-D 3 gpm @ 30-35 psi, 80°F or less

Air 15 SCFM @ 90 psi (6.2 bar)

Voltage

HyperJet 94i-S 460 VAC/125 A/60 Hz, 3ø
HyperJet 94i-D 460 VAC/200 A/60 Hz, 3ø

Water requirements

The HyperJet intensifier pumps each require one water source. Also required are three water drain lines: coolant drain, leakage drain, and bleed-down water. The leakage drain must be separate where local regulations do not permit oil in drains. Specific requirements are defined in the following descriptions.

Cutting water

CAUTION
A high concentration of dissolved solids (especially silicates and calcium) in the inlet water can reduce waterjet nozzle life. If water quality is poor and filtration will not correct it, the customer must add additional water treatment equipment. Contact FLOW Technical Service for more information.

Flow recommends the use of a water softener to pre-treat the cutting water. Systems should be sized for 150% of your pump capacity, and should match your intended maximum duty cycle.

Water pressure

Water pressure to the intensifier pump must stay between 50 and 100 psi (3.4 and 6.9 bar) at all times.

Water flow rate

The minimum inlet water flow rate must be equal to 1.5 times the maximum output flow rate.

Cooling water (to heat exchanger)

A heat exchanger regulates heat build-up in the hydraulic oil. Optimum hydraulic oil temperature is 105°F (40.5°C). Tap water is routed to the heat exchanger in the hydraulic reservoir.

A thermostatically controlled cooling water flow control valve designed for partially open operation is installed in the line to regulate the water flow for maximum water conservation.

Water flow must be sufficient to ensure that the hydraulic oil reservoir temperature is always maintained below 110°F (43°C). Cooling water flow rate is typically 3 gpm (11 lpm) per 50 hp at an inlet water temperature of 60°F (15°C).

Water with low levels of minerals and acid will maximize heat transfer efficiency and heat exchanger life.

- Waterjet systems perform better with soft water.

Drain requirements

Cooling water drain

Cooling water leaving the intensifier pump is considered waste water. This water can be routed to a waste water recovery system, a recirculation system, or a drain—whichever is most applicable for the installation. If the water is reused for cooling, a commercial water cooling system can be used.

If the cooling water is routed directly to a waste water drain, you must have a minimum drain capacity of 9 gpm (34 lpm).

Leakage drain (oil or water)

The pump has a drip pan to collect oil or water leakage from the intensifier seals. Leakage is usually negligible; however, the drain line is sized to accommodate the worst case (if the high-pressure seals fail) of 10 gpm (38 lpm).

Do not connect the leakage water drain to the coolant water drain line or any other pressurized drain system.

Bleed-down water

The bleed-down valve exhausts water through the BLEED DOWN WATER port on the bulkhead.

Water interface connections

Please note the following:

- Flow recommends that you install manual on/off valves in the inlet water and cooling water lines. Locate valves as close as possible to the pump interface connection to make them easier to service.
- Coolant water lines must be made from non-corrosive pipe or rubber hose. Rubber hose per SAE Standard 20R1, 30R1, or equivalent is recommended.
- Cutting water lines (from the filtering system to the intensifier pump) must be as short as possible and must be constructed of PVC, copper, or equivalent. Do not use galvanized iron piping—it will introduce minerals to the water, which will shorten orifice life.

Making the interface connections

- Connect inlet water line to FILTERED WATER IN.
- Connect LEAKAGE WATER to the appropriate drain or bucket (can contain oil).
- Connect BLEED-DOWN WATER to the appropriate drain.

Note: Purge the inlet water lines of debris before completing the connection to the pump.

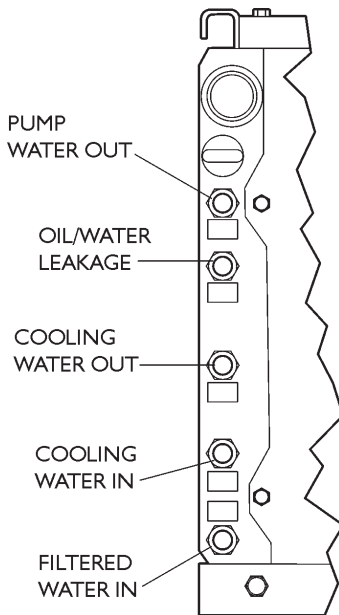

Pump startup sequence

After initial installation, and whenever you perform major service on the intensifier pump, you must follow this startup procedure when putting the equipment back into service. This procedure provides checks to make sure the pump is correctly reassembled.

Before starting the equipment:

- Be sure you know how to stop it.
- Read the manuals, get training from an experienced operator, and review the safety precautions.
- Follow a written checklist that includes an inspection for needed or ongoing service, damaged or missing parts, leaks, and anything that could make equipment unsafe to operate.
- Make sure doors are closed and covers are in place.
- Call out “START-UP” to let anyone in the area know the equipment will be starting up.

WARNING
NEVER operate the pump or intensifier with uncertified parts—this can cause explosive separation of parts and serious bodily injury. Contact FLOW or seek professional installation assistance.

- All operators and service personnel must review the safety precautions in all manuals provided with this equipment before operating the equipment.
- Cutting equipment and nozzle must be installed and working before operating the pump. Operating the pump without proper line restriction will damage high-pressure components.

Starting the pump

CAUTION
Debris in the water supply line can cause extensive damage to high-pressure components. Such damage IS NOT covered by warranty.

1. Flush debris from all water supply hoses before connecting them to the pump.

CAUTION
Never operate the pump without oil—this can cause extensive damage and IS NOT covered by warranty.

2. Fill the pump case(s) with one of the recommended oils (see the list on Page 8).
3. Make sure water lines, air lines, and drain lines are correctly connected and routed.

4. Clear all tools, parts, and rags from around the pump. Check areas in and around the pump for foreign objects and debris.

CAUTION
The inlet water valve must be open before operating the pump. Operating the pump with the inlet water valve closed will cause damage.

5. Open the inlet water valve and check all connections for leaks.

CAUTION
Cutting equipment and nozzles must be installed when operating the pump. Operating the pump without proper line restriction can cause damage.

6. Place the main electrical disconnect in the ON position.
7. Release the E-stop button.
8. Activate FlowCUT and open a part program. Select Run Machine. The screen will display the pump on/off control.

CAUTION
Do not try to tighten any loose or leaking connections while the pump is operating or while the line is pressurized.

9. Turn the pump on by clicking on the pump ON button.
10. When the pump reaches the low-pressure setting, allow it to run 5-10 minutes while checking for leaks or other problems. Correct as required.
11. Click on the high-pressure icon.
12. When the pump reaches 87,000 psi (6000 bar), operate the pump at this pressure for additional 5-10 minutes while checking for leaks. Correct as required.
13. Turn the pump off, exit FlowCUT, and press the E-stop button.

Operating an integrated HyperJet pump

All integrated Flow intensifier pumps are operated using the FlowMaster software controller. See manual M-322, FlowCUT User's Guide, for more detailed information on running the machine. A pump operation button on the FlowMaster Run Machine screen is used for starting and stopping the pump. Select HIGH PRESSURE or LOW PRESSURE for the dual- pressure feature.

IMPORTANT

If you are running a standalone Hyperjet intensifier pump, it will have its own control panel. Turn to Chapter 3 of this manual for details.

Running the pump

When the machine is in position to start a cut, click on the ON pump button. The intensifier pump will not start immediately; first the water booster pump turns on to charge the system. After approximately 5 seconds, the intensifier pump starts and begins ramping up pressure.

The pump uses an electronic proportional control valve to automatically ramp up high-pressure water. The digital high-pressure gauge on the FlowCUT screen indicates the amount of water pressure in the system.

When the system reaches the desired operating pressure, you can begin cutting. Click the OFF pump button to turn off the pump. All system pressure is bled to 0 psi within one second of shutting down the pump.

Using dual pressure

Brittle materials, such as glass, stone, or composites, should be pierced at a lower operating pressure (such as 20,000 psi/1379 bar). To select high or low pressure, highlight either the HIGH PRESSURE or LOW PRESSURE box to the right of the pump on/off button.

- The default setting is HIGH PRESSURE, which is normally set for an operating pressure of 87,000 psi (6000 bar).
- Selecting LOW PRESSURE will lower the pressure, usually to between 15,000–20,000 psi (1034–1379 bar).

Use the LOW PRESSURE setting together with the FlowMaster PIERCE ALL HOLES FIRST function to pierce holes in a given program before cutting.

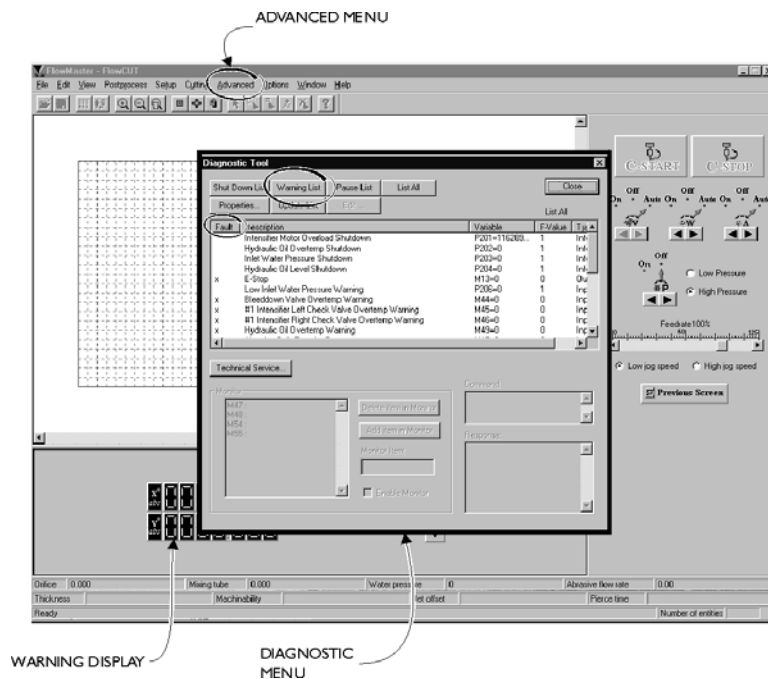

Running the HyperJet 94i-D on one motor

The HyperJet 94i-D can be run in three modes: 100 hp (default mode), 50 hp A, and 50 hp B.

100 hp mode

- In 100 hp mode, the first motor is started, followed by the second motor, and then the system is brought up to pressure.
- Each motor powers one of the intensifiers. Follow the plumbing connecting the motors and intensifiers to determine which motor powers which intensifier.

50 hp A mode

- In 50 hp A mode, only the first motor is used.
- This mode should be used only if there is a problem with the equipment that prevents normal 100 hp operation of the pump, such as malfunction of a single intensifier or motor.

50 hp B mode

- In 50 hp B mode, only the second motor is used.
- This mode should be used only if there is a problem with the equipment that prevents normal 100 hp operation of the pump, such as malfunction of a single intensifier or motor.

Changing pump operation mode

1. Shut down the pump.
2. Open the OPCPump.ini file in the FlowMaster\System directory.
3. Make sure the following line in the header of the file reads:
INIT_WRITE,1 // 1=ENABLE, 0 = DISABLE
4. Locate the pump size variable line. The pump size line of a HyperJet 100 pump operating in default mode will read:
Pump_Size,MicroWin.S-0264.USER1.Pump_Size,,1,P100
5. You can change this line to switch the pump's mode to 50 hp A or 50 hp B.
 - To change the pump to 50 hp A mode, change the pump size line to read:
Pump_Size,MicroWin.S-0264.USER1.Pump_Size,,0,P100
 - To change the pump to 50 hp B mode, change the pump size line to read:
Pump_Size,MicroWin.S-0264.USER1.Pump_Size,,2,P100
6. If FlowMaster was running while you were making the changes to the OPCPump.ini file, you must close the program and restart it in order to activate the changes.
7. Follow the *Pump startup sequence* on page 11 to restart the pump.

Shipping or storing the HyperJet pump

Whenever moving, storing, or shipping a Flow pump, following these guidelines will help prevent damage caused by movement or environmental conditions. These instructions comply with transportation regulations.

Note: U.S. Department of Transportation regulations require that hydraulic fluid be transported only in sealed containers. Before shipping, remove all hydraulic fluid from the oil reservoir.

Service steps

1. Disconnect power and turn off inlet water.
2. Disconnect main motor lead terminations from the motor starter in the machine power enclosure. **DO NOT CUT LEADS.**
Note: Motor leads are terminated with eye lugs and bolted to terminations from the motor starter primary conductors.
3. Remove water filters from housings. Empty and clean the housings, then reinstall without filters.
4. Disconnect the plumbing from the water leakage line.
5. Disconnect customer plumbing from the FILTERED WATER IN bulkhead connection.

Install antifreeze

Notes:

- Use Dow Chemical Dowfrost Propylene Glycol food-grade antifreeze (or equivalent). Antifreeze, container, pump, and hoses must be clean to prevent contamination.
 - Antifreeze **MUST NOT** be introduced into an 87K intensifier.
6. Use a small pump to force clean antifreeze through the cooling water circuit. To ensure that the flow control valve is open, run the pump until the oil is at operating temperature. Otherwise, bypass the flow control valve. A drill-motor operated transfer pump is often adequate. Continue to pump antifreeze until it exits the COOLING WATER OUT connection, then disconnect the hose from the inlet water connection.

7. Remove water from the intensifier inlet water circuit by emptying the filter housings and blowing out the hoses and booster pump using compressed air.

Water in the intensifiers and high-pressure tubing does not need to be removed.

Plug fittings

8. Plug all bulkhead connections. Tie wrap the inlet water line and drain line.

Crating

9. The pump must be shipped on a framed and reinforced wooden pallet designed to isolate and support its weight and load characteristics.
10. Secure the filter bracket so it cannot vibrate.
11. Wrap a plastic band around the horizontal circumference of the pump, protecting all corners with cardboard between the strap and the cover corner. Wrap an additional plastic band around the top and under the frame, also protecting corners with cardboard.
12. The pump cover package must also be fully enclosed in a rigid wooden crate for shipment.

Safety

This chapter contains a comprehensive list of safety precautions that must be followed to ensure safe operation of the equipment. These precautions must be read and understood by everyone operating and maintaining the equipment—before they start working with the equipment. Note that OSHA and state safety agency rules must be complied with in addition to those given in this chapter and elsewhere in this manual. Applicable plant general safety precautions must also be followed.

Safety precautions

FLOW designed your high-pressure waterjet cutting system and related equipment with safety in mind. Throughout the manual, safety precautions and warnings for specific operations are highlighted. Safety precautions are also posted on the equipment. The operator and service personnel shall pay particular attention to these precautions at all times.

Operators of a high-pressure waterjet cutting system must treat the system as they would treat any high-speed cutting tool. Although the waterjet may appear harmless, it is a high-energy cutting tool capable of cutting many non-metallic materials such as composites, plastics, and wood products. Misuse of this equipment or carelessness in its application can be extremely hazardous to operating personnel. Always treat the waterjet cutting system with respect.

Warnings, cautions, and notes

Service procedures in the waterjet manuals include safety warnings, cautions, and notes that must be read, understood, and adhered to. These are specific categories of safety notices, and are defined as follows:

WARNING
Highlights an operating condition or service procedure that can result in death or serious injury to personnel.

CAUTION
Highlights an operating condition or service procedure that can lead to impaired system operation or equipment damage.

Note: Highlights an operating condition or service procedure that is considered essential for efficient operation and service.

Replacement labels

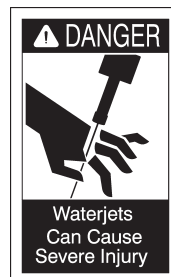

- Part # 006317-1
3.75 x 6 in.
- Part # 009837-1
1.8 x 3 in.

Safety tips

- Do not allow the waterjet stream to touch any part of your body—it will cause serious injury.
- Do not point the waterjet at anyone.
- During equipment maintenance, take the system out of service. The controls must be properly locked and marked with a warning sign.
- All personnel required to perform any system operating or service function must pay particular attention to all warning signs and notices posted in the plant and on the equipment.
- All protective guards, shields, and covers must be in place on the equipment at all times.
- Use cleaning solvents only in well-ventilated areas. Avoid prolonged breathing fumes and contact with skin or eyes.
- First aid facilities must be provided in convenient locations throughout the plant. These locations must be known by all personnel.
- Always keep the work area around the equipment clean and free of debris. Oil spillage results in slippery floors and must be cleaned up immediately.
- Any unfavorable conditions that may result in injuries must be reported to the plant supervisor without delay.
- As a general practice, it is recommended that safety shoes, glasses, and hearing protection be worn by all personnel working around the equipment. Do not wear rings, watches, or necklaces when working around any equipment that has moving parts.

Mechanical system

- Don't start the system unless you know how to stop it.
- Never maintain, service, or clean around the equipment while it is operating.
- Use only the correct tools—wrong tools can cause injury or costly damage to equipment.
- Never climb on or around the equipment on make-shift devices. Use only approved catwalks, ladders, or platforms.
- Do not exceed specified pressure setting limits for pneumatic or hydraulic components. Exceeding these limits may result in serious injury to personnel or damage to the equipment.
- Shield and bundle equipment hoses and cables so they do not obstruct the operator's freedom of movement.

- Be alert at all times when working around the equipment.
- Clear all tools, parts, and rags from moving parts after servicing the equipment.

Electrical system

- Only properly trained personnel shall perform electrical and/or electronic troubleshooting and servicing of electrical devices.
- Always assume that power is ON in all electrical systems. Always check and lock out the main power switches before servicing the equipment. Post a sign, "Maintenance in Progress — Do Not Energize."
- Be aware that live electrical circuits are present in the control console whenever the master disconnect is on, regardless of whether the E-Stop is engaged.
- Disconnect circuit breakers and lock them in the OFF position before servicing the electrical system. If this isn't possible, have someone stand by to prevent someone from powering up the system.
- Take extra precautions when servicing the power system in a damp environment.
- Never alter or bypass protective interlocks or devices unless specifically instructed to do so, and only if all precautions are followed.
- You must give capacitors sufficient time for discharge. If this is not possible, discharging should be done manually and with care.
- Do not use jumper wires across fuses, fuse holders, or breakers.
- Make sure all tools are properly insulated for the job.
- Use only proper test apparatus; check regularly to make sure it is working correctly.
- Use caution when connecting a test probe to test points.
- All replacement wires must conform to the manufacturer's specifications, including color coding, wire numbers, and size.
- Close the control panel doors or junction box covers after servicing.

Waterjet system

- High-pressure water can remain in the system for an extended time after shutting down the water source. Always bleed down system pressure before servicing any part of the system.
- Do not touch weep holes with your bare hands or try to stop water by plugging the holes.
- Remember that the waterjet stream is a knife. Do not introduce anything into its path that you do not intend to cut.
- Wear a face shield when required by the operating instructions.
- Do not remove protective shields from high-pressure tubing. If shields are removed for servicing, they must be replaced before starting the system.
- Torque all fittings to the manufacturer's torque specifications.
- Stepping or leaning on high-pressure tubing can break connections, causing leakage.
- Use only high-pressure fittings, valves, and tubing certified for 87,000 psi (6000 bar) when making alterations or additions to the high-pressure water system.
- Do not alter or eliminate stress relief tubing coils.
- Follow the tubing manufacturer's recommendations for high-pressure tube bending radii.
- Do not exceed specified operating pressures for high-pressure water system components.
- Do not over-torque fittings or bend swivels excessively.
- Follow the manufacturer's recommendations for servicing the equipment, and use only original manufacturer replacement parts.
- Follow the manufacturer's system startup procedure to ensure safe operation.
- Use care when lifting equipment covers during operation.

Protective clothing

Personnel operating hand-held, high-pressure water cutting or cleaning equipment and those working nearby should wear the protective clothing and safety devices described in this chapter.

FLOW recommends that work-site safety personnel approve all safety equipment and clothing for everyone working around waterjet equipment.

Eye protection



- At a minimum, operators must wear safety glasses with side shields and a visor, or goggles and a visor, to guard against spray and flying debris.
- All eye protection shall meet appropriate ANSI requirements for that type of eye protection.
- Some states and countries have their own eye protection rules that must be followed.

Head protection



- Helmets must be worn at all times by all personnel within the work area.
- Helmet material must withstand mechanical shock to 10 G in 8 ms without fracturing.

Hand protection



- The operator must wear gloves at all times. Leather gloves are preferred.

Foot protection



- Safety footwear with steel toe-caps 0.02-in. (5 mm) thick (minimum) must be worn. The toe cap must cover at least 30% of the footwear length.
- For some applications, footwear must be equipped with metatarsal guards to provide instep protection.

Hearing protection



- Operators and other personnel exposed to noise levels of more than 90 dBa for more than 1 hour must wear suitable ear protection. Ear plugs and muffs are usually adequate.

Body protection



- Waterproof garments only protect the operator from spray and flying debris. They DO NOT provide any protection from direct jet impact.

WARNING
NEVER point a waterjet cutting or cleaning tool at yourself or at any person. Do not aim any waterjet tool at anything you do not want to cut.

Emergency medical information

Anyone who receives equipment-related injuries while operating high-pressure water equipment should be given immediate hospital attention. It is vital that medical personnel have information about this type of injury. Therefore, all waterjet operating personnel should carry a waterproof emergency medical tag or card that describes their work and the nature of injuries inherent in using waterjet cutting devices. The card illustrated below can be purchased from Flow (A-8466).

The tag or card should contain the following standard information:

MEDICAL ALERT

This card is to be carried by personnel working with high-pressure waterjet equipment. Obtain medical treatment immediately for ANY high-pressure waterjet injuries.



FLOW INTERNATIONAL CORPORATION

23500 64th Avenue South
Kent, Washington 98032 USA
(253) 850-3500



This person has been working with water jetting at pressures to 92,000 psi (634 MPa, 6345 bar) with a jet velocity of 3900 fps (1190 mps). This should be taken into account during diagnosis. Unusual infections with microaerophilic organisms occurring at lower temperatures have been reported. These may be gram-negative pathogens, such as those found in sewage. Bacterial swabs and blood cultures may therefore be helpful. A local poison control center should be contacted for additional treatment information.

Notes

Operating the Standalone Pump

Basics of pump control

There are three types of screens: main control screens, pump status screens, and pump configuration screens.

The configuration screens are where all operating configuration changes are made, using the touch keys on the screen. Other screens are for displaying data to indicate how the pump is running; no changes can be made to the pump from these screens.

Main control screens

- Start
- Main Run
- Change Pressure Setpoints
- Dual Pressure Control
- Boost Pump Control

Pump status screens

- Pump Status 1
- Pump Status 2
- Analog Input Status
- Pump Shutdowns
- Pump Warnings

Configuration screens

- Configuration screen 1
- Configuration screen 2
- Configuration screen 3
- Configuring the clock
- Defaults
- Display Services

Units

Note that the units in the screens in this chapter are PSI for pressure measurements, and °F for temperature measurements. These units can be changed to Bar for pressure, and °C for temperature; see the *Defaults* screen.

Main control screens

Start Screen

The Start Screen shows the Flow logo and a single button.

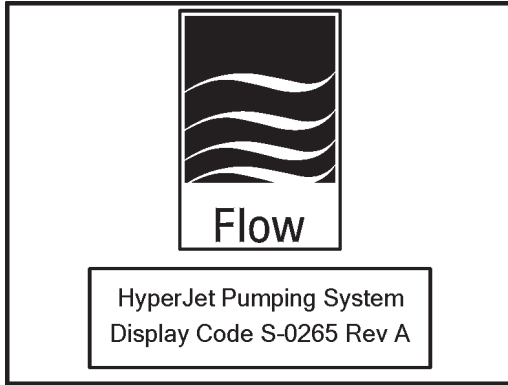

Note: The revision letter may be different for your machine.

Navigation

- Touch the button to continue to the *Main Run Screen*

Main Run Screen

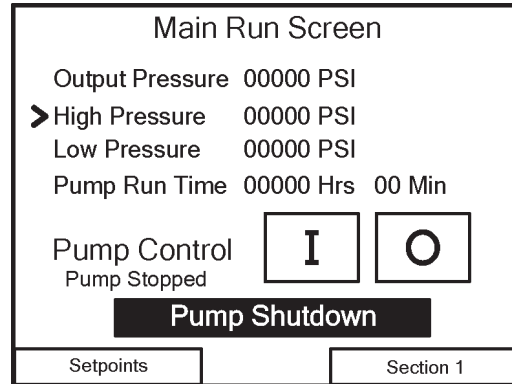

From the *Main Run Screen*, you can **start [I]** and **stop [O]** the pump. The screen also shows the pump's main parameters: output pressure, high- and low-pressure settings, pump run time, pump status (stopped or running), and whether there is a warning or shutdown condition present.

The arrow ➤ indicates whether the pump is in high- or low-pressure, based on the status of the Dual Pressure command.



If any warnings or shutdowns occur, a message will be displayed on this screen. Touch the message to continue to the *Pump Shutdowns* screen or *Pump Warnings* screen for more information.

Navigation

- Touch the **Setpoints** button to continue to the *Change Pressure Setpoints* screen
- Touch the **Section 1** button to continue to the *Pump Status 1* screen

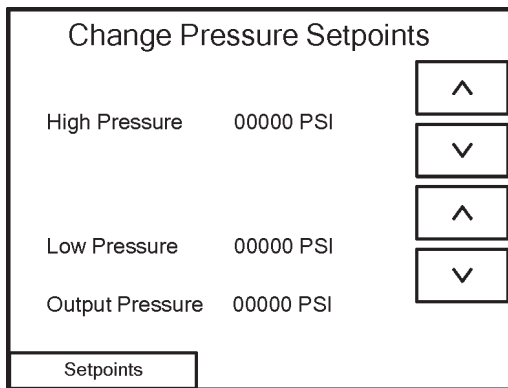
Change Pressure Setpoints



From the *Change Pressure Setpoints* screen, you can view and adjust the pump's pressure settings by touching the  and  buttons.

Navigation

- Touch the **Setpoints** button to continue to the *Dual Pressure Control* screen

Dual Pressure Control

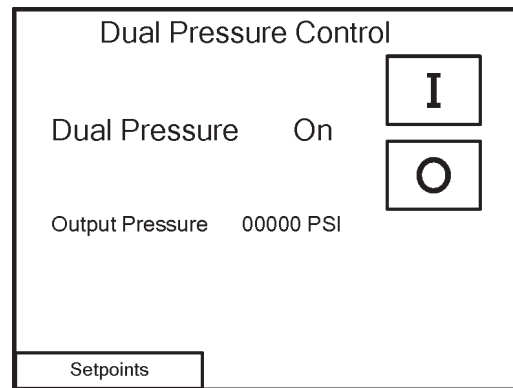

The *Dual Pressure Control* screen will indicate whether the pump is operating at either **High** or **Low** pressure.

- If the indicator reads "High," the pump is at or near the high-pressure setpoint.
- If the indicator reads "Low," the pump is at or near the low-pressure setpoint.

Use the **[I]** and **[O]** buttons on this screen to turn dual pressure on and off, and refer to the Output Pressure reading to confirm the status of dual pressure.

Dual pressure can also be controlled from the terminal block input. If the terminal block input is Off, then this screen allows you to test high pressure. If the terminal block input is On, then you cannot force it to low pressure.

Navigation

- Touch the **Setpoints** button to continue to the *Boost Pump Control* screen

Boost Pump Control

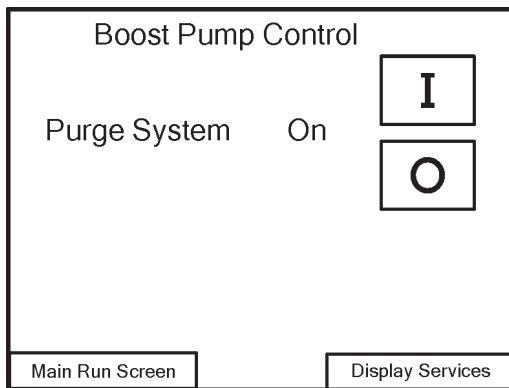

When the pump is first installed or high-pressure tubing is replaced, you must purge the system by sending pressurized water through it. Touch the **[I]** button while the pump is off to energize the boost pump and purge the system.

Note: The operator must *block* the bleed-down to drain so the water can flow through the high-pressure tubing, then open the bleed-down to drain when purging is finished so the pump can operate normally.

Turn off the purge system by touching the **[O]** button, by cycling power to the system, or by starting the pump.

Navigation

- Touch the **Main Run Screen** button to return to the *Main Run Screen*
- Touch the **Display Services** button to continue to the *Display Services* screen

Pump Status screens

The Pump Status screens display information about the health indicators of the pump.

Pump Status 1

Pump Status	
Output Pressure	00000 PSI
Pump Run Time	00000 Hrs 00 Min
Oil	00000 F
Inlet Water	00000 F
CV 1 Right	00000 F
CV 1 Left	00000 F
CV 2 Right	00000 F
CV 2 Left	00000 F

Status
Section 2

The first *Pump Status* screen shows the status of the various temperature indicators, plus the output pressure and current pump run time.

Navigation

- Touch the **Status** button to continue to the second *Pump Status* screen
- Touch the **Section 2** button to go to *Configuration Screen 1*

Pump Status 2

Pump Status	
Pump #1	
SPM	00000
Shift Ratio	00000
Shifts	00000 0000
Pump #2	
SPM	00000
Shift Ratio	00000
Shifts	00000 0000

Status

The second *Pump Status* screen shows the status of the intensifiers:

- Shifts per minute
- Shift ratio
- Total number of shifts

Navigation

- Touch the **Status** button to continue to the *Analog Input Status* screen

Analog Input Status

Analog Input Status	
Enable Spare Analog Inputs	<input type="checkbox"/>
Enabled	
Spare 1	00000
Spare 2	00000

Main Run Screen

You can enable up to two spare analog inputs:

- [I] = enabled
- [O] = disabled (default)

Once enabled, data from these inputs will also be displayed on this status screen.

Navigation

- Touch the **Main Run Screen** button to return to the *Main Run* screen.

Pump Shutdowns

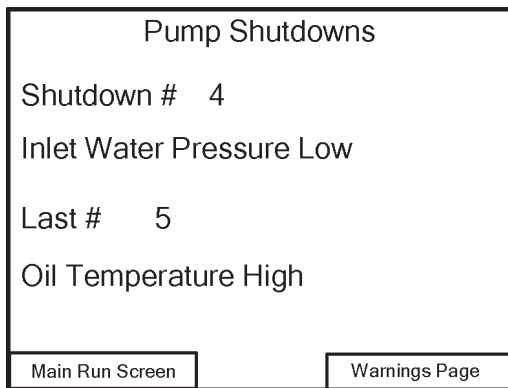

The *Pump Shutdowns* screen shows the current reason for the pump shutting down, along with the message number assigned to the shutdown.

The screen also shows the reason for the last pump shutdown.

Navigation

- Touch the **Main Run Screen** button to return to the *Main Run Screen*
- Touch the **Warnings** page button to continue to the *Pump Warnings* screen

Pump Warnings

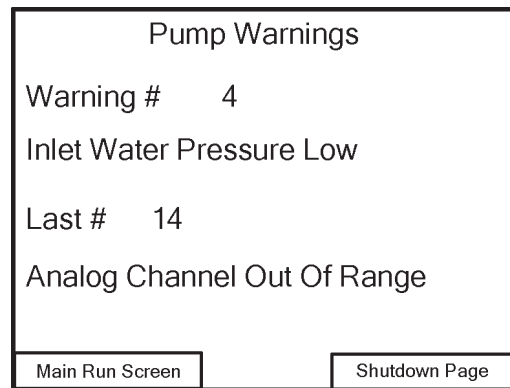

The *Pump Warnings* screen shows the current pump warning, along with the message number assigned to the warning.

The screen also shows the reason for the last pump warning.

Navigation

- Touch the **Main Run Screen** button to return to the *Main Run Screen*
- Touch the **Shutdown Page** button to continue to the *Pump Shutdowns* screen

Configuration screens

The Configuration screens display information about the pump's current configuration. You can also change the configuration of the pump's UHP offset and pressure points on these screens.

Configuration Screen 1

Configuration Screen 1	
Pump Mode	00000
Pump Units	00000 F/PSI
Pump Size	00000 50Hp
Ramp Time	00000
Datalog Interval	00000
Boost On Delay	00000
Boost Off Delay	00000
Motor 2 On Delay	00000
Setpoints	Defaults

The indicators on *Configuration Screen 1* show how the pump is running.

- Set **Pump Mode** to "1" for standalone operation.
- **Pump Units** are "0" for °F/Psi and "1" for °C/Bar.
Note: do not change this while the pump is running!
- **Pump Size** is "0" for 50HpA, "1" for 100Hp, and "2" for 50HpB (see the *Defaults* screen for a definition of these pumps)
- **Ramp Time** can range from 20 to 100 (2–10 seconds)
- **Datalog Interval** time can range from 50 to 3000 (5–300 seconds) between samples. The shorter the interval, the higher the resolution of the data, but the shorter the time span of the total data set.
- **Boost On Delay** can range from 10 to 25
- **Boost Off Delay** can range from 10 to 35
- **Motor 2 On Delay** can range from 10 to 30

To change a value, touch that number on the screen. A keypad will appear; enter the desired value, then touch the **ENTER** button to accept the value.

Navigation

- Touch the **Setpoints** button to continue to *Configuration Screen 2*
- Touch the **Defaults** button to continue to the *Defaults* screen

Configuration Screen 2

Configuration Screen 2	
Oil Level Delay	00000
Aux Feedback Delay	00000
CV Temperature	00000 F
Water Pressure Delay	00000
Overpressure Delay	00000
Overpressure Value	00000 PSI
Setpoints	

The indicators on *Configuration Screen 2* shows how the pump is configured.

- **Oil Level Delay** can range from 10 to 50
- **Aux Feedback Delay** can range from 60 to 600
- **CV Temperature** can range from 40–80°F (25–45°C) above inlet water temperature
- **Water Pressure Delay** can range from 50 to 600
- **Overpressure Delay** can range from 300 to 6000
- **Overpressure Value** can range from 93500–96500 psi (6447–6657 Bar)

Navigation

- Touch the **Setpoints** button to continue to *Configuration Screen 3*

Configuration Screen 3

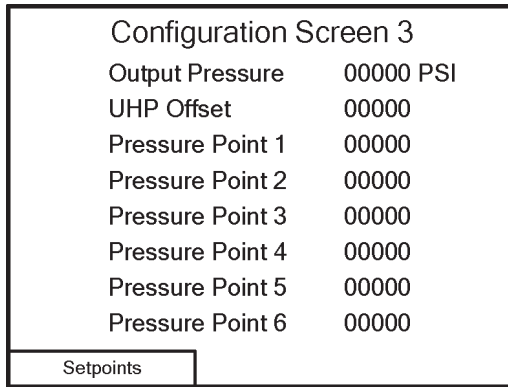

Configuration Screen 3 shows the UHP Offset and Pressure Point values, which can be changed to affect the behavior of the pump.

To change a value, touch that number on the screen. A keypad will appear; enter the desired value, then touch the **ENTER** button to accept the value.

- **UHP Offset.** This value is added to or subtracted from the raw analog input from the UHP sensor to raise or lower its value before scaling. Compare to a calibrated analog gauge to adjust this.
- **Pressure Points** are values to add to or subtract from the raw analog output which are used to linearize the hydraulic pressure to the pumps. Point 1 is adjusted when the commanded pressure is 25,000 psi (1720 bar). The rest are adjusted every 10 Kpsi (690 bar) above that. Positive values raise the hydraulic pressure.

Review the instructions for adjusting the hydraulic controller if the pressure is off at the top end.

Navigation

- Touch the **Setpoints** button to configure the clock

Configuring the clock

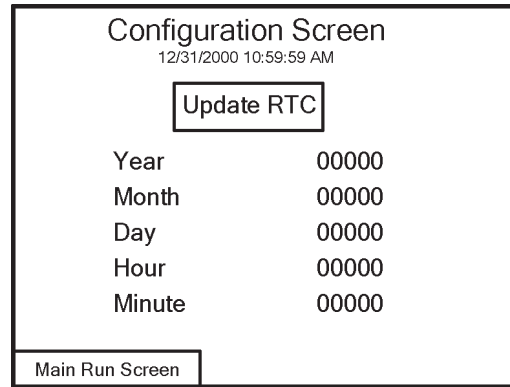

This Configuration screen shows the pump's time settings, which are used for the time/date stamp on the datalog. If the clock is not set the datalog still functions, but every event will have the same date and time.

You can change any of the time variables by touching the number you want to change. A keypad will appear on the screen. Touch the numbers to enter the desired value and then touch the **ENTER** button to accept the value.

When you're done updating the clock values, touch the **Update RTC** button to load the values.

Accepted values are:

- **Year** – 7 to 99
- **Month** – 1 to 12
- **Day** – 1 to 31
- **Hour** – 0 to 23 (uses military time)
- **Minute** – 0 to 59

Navigation

- Touch the **Main Run** Screen button to return to the *Main Run Screen*

Defaults

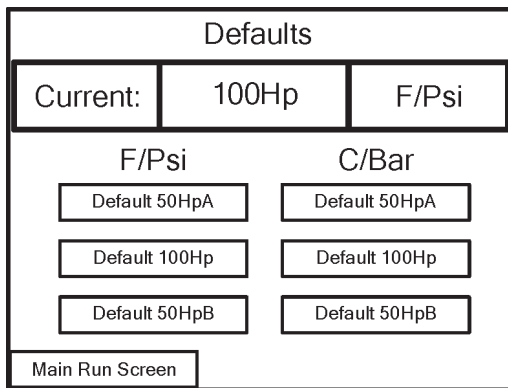

From the *Defaults* screen, you can quickly reconfigure the pump to its default settings. The pump's current configuration is displayed at the top of the screen; this example shows the 100 hp setup.

- **50HpA** – is a 100 hp unit running only the #1 motor/intensifier (the #1 motor is closest to the control enclosures)
- **50HpB** – (only valid with a 100 hp pump) uses the #2 motor/intensifier (the motor farthest from the control panel)
- **100Hp** – (only valid with a 100 hp pump) uses both motors

To restore the default settings, touch the button that corresponds to the original configuration, in the units you want pump status information to be displayed in (°F/psi or °C/Bar).

Navigation

- Touch the **Main Run Screen** button to return to the *Main Run* screen

Display Services

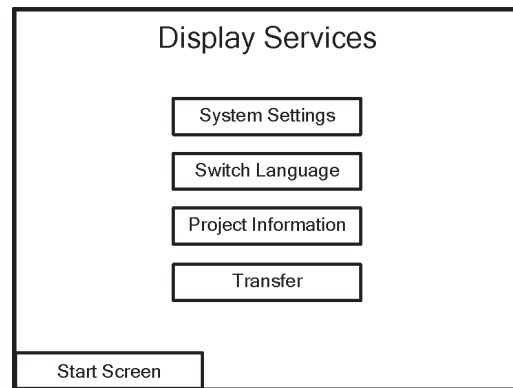

From the *Display Services* screen, you can change the display settings of the control panel, view information about the program controlling the pump, or download a new program.

- **System Settings** – to adjust the display contrast, calibrate the display, or clean the display.
- **Switch Language** – has no function at this time.
- **Project Information** – to view data about the display and the program being used.
- **Transfer** – to download a new program.

Navigation

- Touch the **Start Screen** button to return to the *Start* screen

Notes

Maintenance and Troubleshooting

Periodic maintenance

Periodic maintenance is service to be performed on the equipment at regular intervals, designed to help minimize unscheduled production down time and premature parts failure. Flow recommends that you keep detailed service records to help you prepare a maintenance schedule that is compatible with your application and production requirements.

Maintenance tips

The following tips could help avoid unscheduled downtime.

- Stock enough spare parts to get you through unscheduled shutdowns and reduce the need to order parts on a rush basis.
- Practice good housekeeping in the work area.
- Assign a complete set of service tools to the workstation.

Maintenance precautions

- Do not lubricate the motor excessively or too frequently.
- Protect all machined and lapped mating surfaces against nicks, scratches, and burrs.
- Carefully clean and blow out all parts being reassembled. Do not use paper towels or create airborne dust.
- Do not use any substitutes for the fluids, sealants, and lubricants recommended by Flow.

- Clean off grease fittings before connecting grease gun to avoid injecting dirt-filled grease into the bearings.
- Correctly lubricate new bearings before operation.

General precautions

Observe the following general precautions at all times. Review the safety information in Chapter 2 before performing any maintenance or service. Do not make any unauthorized changes to equipment or components.

Electrical

- Maintain all electrical components, protective guards, and shutdown devices according to approved practices.
- Make sure power cannot be applied to equipment during maintenance work.
- Before servicing, use a volt meter to make sure the system is not energized. Take extra precautions when servicing the electrical system in a damp environment.
- Never use jumper wires across fuses, fuse holders, or breakers.
- Do not use metal rulers, flashlights, pencils, or tools that have exposed conducting material.
- De-energize all equipment before connecting or disconnecting meters or test leads.
- When connecting the volt meter to terminals for measurement, use a range higher than the expected voltage.

- Replacement wires must conform to the manufacturer’s specifications, including proper color coding and wire numbers.

Mechanical

- Use only high-pressure fittings, valves, and tubing certified for 92,000 psi (6483 bar) when making changes to the high-pressure water system.
- Immediately repair any leaks in fittings or connections. Torque all fittings to the manufacturer’s specifications.
- When pressurizing any new, rebuilt, or recently serviced high-pressure component, clear all personnel from the immediate area until system pressure has been applied for three minutes and cycled on and off at least three times. Increase pressure slowly, a maximum of 20,000 psi/min (1380 bar/min).
- Do not touch high-pressure leaks.
- Bleed down system pressure before servicing any part of the system. Never tighten pressurized fittings.
- Follow the manufacturer’s recommendations for servicing the equipment, and use only original manufacturer replacement parts.
- Inspect the entire system before operating it. Correct any fault or malfunction.

Tools

- Use only approved test equipment, and check it regularly for correct operation and calibration.
- Use the correct tools—the incorrect tool can result in injury to personnel or costly damage to the equipment.
- Clear all tools and rags from around the machine after service and before starting the equipment.
- Use only approved work platforms. Never climb on or around the equipment using makeshift devices.

Protective clothing

- Do not wear loose clothing while working around rotating parts of machinery.
- Pressurized air can drive particles into eyes and skin if handled improperly. To prevent injury, use appropriate protective equipment and clothing and exercise extreme caution.

Hydraulic oil

Use an oil that does not contain anti-wear additives; the following oils are recommended, but other manufacturer’s equivalents can be used:

- Mobil DTE Medium
- Shell Turbo T 46
- Chevron Turbine Oil GST 46
- Texaco Regal R&O 46

Kinematic viscosity	240 SSU @ 100°F (38°C)
Reservoir capacity	HyperJet 94i-S: 25 gal (95 L) HyperJet 94i-D: 37 gal (140 L)
Filtration	6 microns, continuous flow
Cooling	Oil-to-water heat exchanger
Optimum oil temperature	105°F (40.5°C)

Inspection & maintenance schedule

Flow equipment has been designed for long service life. However, maximizing the life, safety, and efficiency of the equipment is dependent on daily inspections and regular maintenance. Periodic maintenance can take the form of regularly scheduled preventive maintenance, such as the items listed below. It also includes replacing worn parts that have reached the end of their service life.

Every day

Before startup

- Inspect pump, high-pressure tubing, connections, and valves for leakage. Correct any problems before starting the pump.
- Check the oil level in the pump.
- Check the main electrical disconnect for “Out of Service” tags and check all around the equipment for indications of maintenance work in process.

After startup

- Listen for unusual sounds as the pump starts and water pressure increases. Look for leaks.

End of shift

- Clean machine work area.

Troubleshooting

The troubleshooting guide will help you identify the probable cause of a system malfunction and establish the most effective corrective action.

Troubleshooting tips

The following tips have been helpful in isolating system malfunctions and in correcting problems quickly.

- Listen to the machine and watch it operate. Learn to recognize the normal noises, temperature, and operating conditions. This will increase your ability to notice any unusual machine behavior.
- Keep a record of all service performed on equipment. This will provide valuable information to help you stock spare parts and schedule maintenance.

A maintenance and service log is located at the end of this chapter.

Weep holes

Weep holes provide an outlet for high-pressure water in case of seal problems, and thus can help you identify problems with the pump. Leakage is usually caused by a failed high-pressure seal, but could also be caused by:

- Loose or leaking end cap (refer to the intensifier manual, M-376, 94K Hyperpressure™ Intensifier)
- Failed check valve body o-rings
- Cracked or scored high-pressure check valve body
- Fractured fittings, such as tees, elbows, or couplings
- Loose high-pressure connections
- Damaged high-pressuring tubing/fitting conical seal

Troubleshooting the high-pressure components

If you have questions about anything on the troubleshooting tables, contact FLOW Technical Service.

Using the troubleshooting table

The probable causes of each malfunction are listed in order, starting with the most likely to occur. Each corrective action is a condensed, step-by-step summary of the service required to fix the problem.

When you encounter a system malfunction, refer to the troubleshooting table and:

1. Define the problem.
2. Locate the symptom that most closely resembles the problem.
3. Identify the most likely probable cause.
4. Follow the corrective action procedure.

If the symptoms in the guide do not correspond to your malfunction, or if the problem is not eliminated by the recommended corrective action, contact Flow Technical Service.

Troubleshooting the intensifier pump

Follow this troubleshooting table if you experience any of the following conditions. Required minor and major maintenance procedures and other service procedures are located in this chapter.

1. Intensifier	
Note: Verify that the intensifier is operating correctly by looking for seal leakage and checking for high temperatures. Refer to manual M-376, Hyperpressure™ Intensifier.	
2. Intensifier overspeeding	
Intensifier problem	Check intensifier for leaks and high temperatures.
Orifice problem	Check orifice(s) for correct size and condition.
High-pressure water leak	Check entire installation for evidence of leaks.
Low inlet water pressure	Clogged inlet water filters or other inlet water line restriction. Check filters and lines; replace as needed. Check filter differential pressure indicator and inlet water pressure switch; replace as needed.
Leaking auto bleed-down valve	The valve is hot to the touch; rework or replace the valve.
3. Oil pressure and high-pressure water pressure are satisfactory, but water flow through the nozzle is low	
Flow restriction in the downstream high-pressure plumbing or components	<ol style="list-style-type: none"> 1. Inspect the high-pressure inline filter, if installed. 2. Check for blockage of tubing and components; remove any blockage. 3. Check for correct operation of on/off valve. Replace components as required.
4. Supply oil pressure is OK, but high-pressure water pressure is low at the pump and nozzle	
Oil return pressure is too high	There may be a restriction in the return line from the intensifier to the hydraulic pump. Cold oil at startup. Not a significant problem.
5. Supply oil pressure and high-pressure water pressure are low at the pump	
Intensifier problem	Check intensifier for leaks and high temperatures. Refer to manual M-376.
Orifice problem	Check orifice(s) for correct size and condition.
High-pressure water leak	Check entire installation for evidence of leaks.
Leaking auto bleed-down valve	The valve is hot to the touch; rework or replace the valve.
Pressure control problem	The pressure control system has malfunctioned. Check the system and adjust or replace parts as required.
6. No supply oil pressure or high-pressure water pressure	
No hydraulic oil in the system	Turn the intensifier pump off. Examine all suction and delivery lines for leaks; check the oil level in the reservoir. Remove oil spillage.
Broken motor shaft, pump shaft, or coupling	Examine the motor and pump shafts and coupling. Replace as required.
Defective pressure control valve	Check the pressure control system and adjust or replace parts as required.
Defective hydraulic pump	Replace the hydraulic pump. See <i>Replacing the hydraulic pump</i> .

7. Hydraulic oil is milky or foamy	
Leaking heat exchanger	<ol style="list-style-type: none"> 1. Test the heat exchanger either removed or in place, for a static air leak at 150 psi (10.3 bar). Replace as necessary. Drain oil from the reservoir, hydraulic pump case(s), hoses, and intensifier assembly(ies). Refill the reservoir and pump case with clean hydraulic oil. 2. If the heat exchanger is not defective, look for a source of water vapor condensation.
8. Oil is leaking around pump shaft	
Defective hydraulic pump seal	Replace the seal; check for leaking after replacement. See <i>Replacing the shaft seal</i> .
9. Hydraulic oil contains metallic particles	
Excessive wear of the intensifier low-pressure cylinder. Immediately stop the pump if one or more of the listed signs is present.	
<i>Signs of excessive wear: hydraulic system is running hot, uneven stroking, unusually high hydraulic pump noise during shifting, sudden drop in the intensifier's ability to meet demand for high-pressure water, and severe pressure fluctuation in the output water</i>	<ol style="list-style-type: none"> 1. Disassemble the intensifier, inspect the components, and rebuild, replacing all worn parts. Inspect hoses. 2. Drain, thoroughly clean, and refill the hydraulic oil system (see <i>Cleaning a contaminated hydraulic system</i>). 3. Replace the oil filter. 4. Reinstall the intensifier and return the equipment to service.
Excessive wear of the hydraulic pump. Immediately stop the pump if you see one or more of the listed signs.	
<i>Signs of a faulty hydraulic oil pump: higher-than-normal pump noise, inability to maintain the rated hydraulic oil pressure, or loss of water pressure</i>	<ol style="list-style-type: none"> 1. Drain and thoroughly clean the hydraulic oil system. Replace the hydraulic pump. Refill the hydraulic oil reservoir and pump case; see <i>Cleaning a contaminated hydraulic system</i>. 2. Return the pump to service.
Using the wrong oil	Drain, thoroughly clean, and refill the hydraulic oil system (see <i>Cleaning a contaminated hydraulic system</i>).
10. Excessive pump noise and loss of oil pressure	
Insufficient inlet hydraulic oil flow to the pump	Make sure the reservoir is full of oil.
Air in oil	Inspect suction lines for leaks.
Water in oil	Inspect oil in reservoir. See Item 7 of this troubleshooting guide.
Malfunctioning hydraulic pump	Replace the hydraulic pump (see <i>Replacing the hydraulic pump</i>).
11. Orifice assembly life is too short	
Poor water quality	<ol style="list-style-type: none"> 1. Check the inlet water filter elements. Inlet water must be filtered to 0.5 micron and have a pH value of 6-8. Replace filter elements if clogged. 2. If applicable, check the deionization and water treatment systems.
Clogged or ruptured delivery system component filter	Remove and inspect filters; replace if clogged or ruptured.
12. Attenuator is leaking water from end cap weep hole	
There is a loose connection at outlet or inlet fitting to attenuator	Loosen the 1/16-in. tubing gland nut and torque the fitting adapter into the attenuator housing to 60-75 ft-lb (81-102 N-m). Retorque the gland nut to 60-75 ft-lb and check for leaks. If leaking continues, replace the fitting insert.

13. Attenuator is leaking water between the main housing and end cap	
A leak in this location is not field repairable. Do not attempt to repair. Contact Flow Technical Service.	
14. High-pressure tubing is leaking	
Excessive torsional movement or alternating load (relative movement of fitting components)	Re-torque the fitting to recommended torque values; repair or replace as required.
High-pressure collar incorrectly installed	Allow 2 to 3 threads between collar and tip.
Coning and/or threading of tubing is incorrect	Recone and rethread the leaky fitting if retorquing does not eliminate leakage.
Eroded fitting	Replace fitting.
15. Electric motor will not start	
E-stop is engaged	Release the E-stop.
Abrasive proximity switch is open	Refer to manual M-359, Paser ECL Plus.
Main electrical disconnect is open	Close the main electrical disconnect.
Line fuses are blown or missing	Check for the cause of blown or missing fuses. Replace affected fuses.
Motor relay is open	Check wiring diagram for a control relay. Replace relay if defective.
Defective motor starter coil	Check for defects by testing with power applied to the coil. Replace motor starter coil if defective.
Start circuit is wired incorrectly	Check wiring against wiring diagram and correct all errors.
16. Electric motor will not stop	
Defective motor starter	Check relays and replace if defective.
Stop circuit is wired incorrectly	Check wiring against wiring diagram and correct all errors.
17. Electric motor is excessively noisy.	
No bearing lubrication	Lubricate electric motor bearings.
Loose mounting bolts	Adjust and tighten mounting bolts.
18. Electric motor runs briefly, then stops	
Loss of one phase of electric power	Make sure all lines are energized. Correct power loss problems as necessary.
Magnetic overload adjustment is set too low	Readjust the overload to a higher setting, but do not exceed 130% of the motor's full load current.

Troubleshooting the pump using FlowSense

Pumps running with a FlowMaster controller are continuously monitored by FlowSense, a diagnostic program that monitors a number of system conditions, some of which are specific to pump conditions. Sensors located on the pump enable FlowSense to alert the operator of pump conditions that will require attention. To indicate a warning, the colors of the display are inverted and will blink. If a shutdown condition exists, a dialog box will appear.

Warning conditions

There are four warning conditions for the pump:

- Low inlet water pressure
- High hydraulic oil temperature
- High check valve temperature
- High bleed-down valve temperature

Shutdown conditions

- Low inlet water pressure
- High hydraulic oil temperature
- Low hydraulic oil level
- Intensifier motor overload
- Emergency stop

To investigate the cause of the fault, and how it can be corrected:

- Go to Run Machine and click on **Advanced | FlowSense diagnostic** in the menu bar. This screen is shown below.
- In the Flow Sense dialog box that is displayed, locate the X in the Fault column and highlight that row.
- Click on the Properties button.

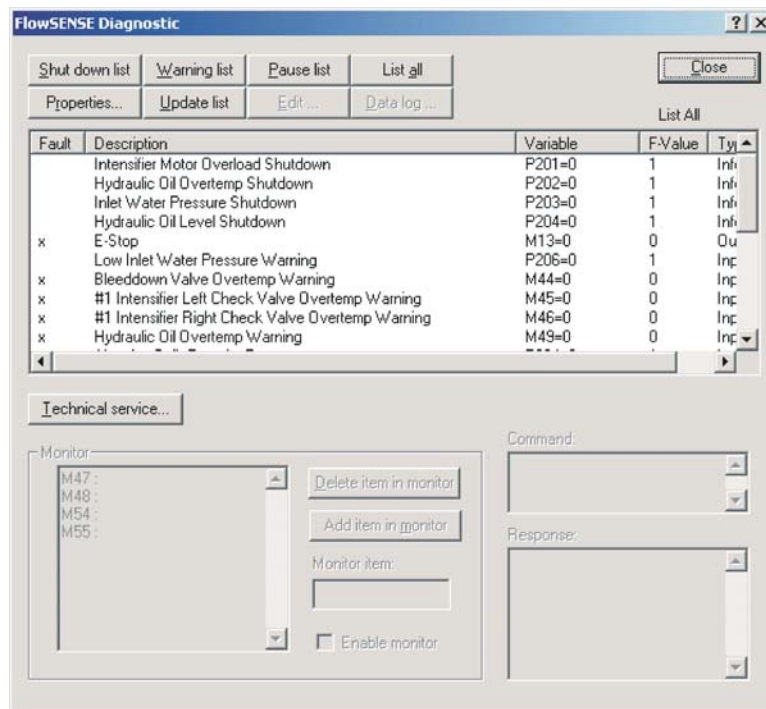

Warning and shutdown conditions

1. Low inlet water pressure (warning and shutdown)	
Filters are dirty	Replace 0.5 and/or 1 micron inlet water filters.
Inlet water turned off or incoming water supply interrupted	Inspect supply valves and hoses.
2. High hydraulic oil temperature (warning and shutdown)	
Incorrectly adjusted cooling circuit	Adjust cooling water flow control valve on pump bulkhead.
Faulty heat exchanger	Inspect and replace heat exchanger.
Damaged intensifier low-pressure cylinder	Refer to manual M-376, Hyperpressure™ Intensifier
3. High check valve temperature (warning)	
Worn check valve	See <i>Servicing the check valve</i> in manual M-376, 94K Hyperpressure™ Intensifier
Fractured check valve body	See <i>Servicing the check valve</i> in manual M-376, 94K Hyperpressure™ Intensifier
Fractured outlet check valve seat	See <i>Servicing the check valve</i> in manual M-376, 94K Hyperpressure™ Intensifier
Damaged outlet check valve poppet	See <i>Servicing the check valve</i> in manual M-376, 94K Hyperpressure™ Intensifier
4. High bleed-down valve temperature (warning)	
Worn bleed-down valve	See <i>Servicing the bleed-down valve</i>
Worn or damaged bleed-down valve poppet and or seat	See <i>Servicing the bleed-down valve</i>
Fractured bleed-down valve seat	See <i>Servicing the bleed-down valve</i>
5. Low hydraulic oil level (shutdown)	
Oil level in reservoir is low.	Check for leaks; add hydraulic oil. Note: Make sure the oil level is between the high level mark and the top edge of the indicator glass. An oil shutdown will occur approximately 1 in. below the high level mark.
6. Intensifier motor overload (shutdown)	
Incoming voltage is low on one or more 3-phase legs.	Check plant power supply.
Motor starter failure.	Check operation of contactor; replace if necessary.
Hydraulic pump is seized or bound.	Inspect hydraulic pump.
Motor is faulty.	Replace if necessary.

Notes

Servicing the Pump

The service procedures contain step-by-step instructions, and most include illustrations to help explain how to service the equipment. Service instructions cover how to replace parts during scheduled or unscheduled maintenance, and also include preventive maintenance procedures to help ensure trouble-free operation. Refer to the illustrations in the chapter, plus the engineering drawings in Chapter 5, to identify parts.

- for intensifier components—refer to manual M-376, HyperPressure™ Intensifier

Service tips

Review the safety precautions in Chapter 2 and the general maintenance tips at the beginning of this chapter before starting any maintenance or service work. If you have questions about any service, contact Flow Technical Service.

- Inspect the equipment every day before operating it. If you see any problem, refer to the troubleshooting guide and related service procedure(s).
- Read and understand each service procedure before starting any work. Pay particular attention to the precautions in the service procedures.
- Maintain records of service performed on the machinery. This will provide valuable information to help you restock spare parts.
- If applicable, turn off the electrical power and relieve system pressure before starting any service. If you must perform a service procedure while power to the equipment is on, or while the system is pressurized, take extra precautions to avoid injury.
- Handle critical parts with care and avoid scratching or denting the high-pressure water system components. Routinely check for loose bolts or wire connections.
- Protect all machined and lapped mating surfaces against nicks, scratches, and burrs. Carefully work out any damage to seal wiping surfaces, or seal damage and leaks will be a recurring problem.
- Do not use a substitute for the fluids, sealants, and lubricants recommended by Flow. Clean off grease fittings before connecting grease gun to avoid injecting dirt-filled grease into the bearings.
- New bearings are frequently packed with only a light shipping grease. Be sure they are properly lubricated before operation.
- Make every effort to find a clean service area. Do not tear down parts in the same area where you are cleaning parts. Airborne dirt and abrasive will seriously shorten component life.
- Only clean parts with fresh, clean solvent that does not leave a residue (such as Citra-safe or isopropyl alcohol). Flow recommends that you set up a dedicated solvent tank for these critical parts. Contamination from other industrial parts will seriously shorten component life.
- Carefully clean and blow out all parts being reassembled. Do not use paper towels. Do not create airborne dust.
- Check around the equipment for parts, tools and rags; remove them before starting the equipment.

Service notes

The following recommendations were provided by Flow customers and technicians. Following this advice can lead to lower repair costs, shorter repair times, and increased service life.

- Monitor water seepage from end cap weep holes. If seepage is cold (same temperature as inlet water), it is usually not necessary to change seals, but you should schedule maintenance as soon as possible. If seepage is hot, shut down the system and repair the pump. Cracked parts and leakage from the check valve **MUST** be repaired immediately.
- All threaded high-pressure connections require an even coating of Blue Lubricant (A-2185). Substitute no other product.
- All parts that contain high-pressure water (cylinder, check valve housing, tubing) are susceptible to stress fatigue accelerated by stress risers. Stress risers result when scratches, nicks, or other surface disruptions are present. Rework all such damage or replace the component.
- Life expectancy of high-pressure water seals and other high-pressure parts is related to the stress on the parts, and is a function of stroke rate, water pressure, and inlet water temperature. Exceeding pump ratings can lead to increased costs and downtime.

Torque specifications

Refer to the following table when specific torque requirements are not listed in a service procedure.

CAUTION
Never torque mounting bolts and machine screws beyond the manufacturer's recommended limits.

The torque values for high-pressure water assemblies and fittings are listed in U.S. Customary System foot-pounds (ft-lb) and Système International (SI) Newton-meters (N-m).

High-pressure gland nuts	U.S. ft-lb	SI N-m
1/4 in.	15–25	20–34
3/8-in.	35–45	47–60
3/16-in.	60–75	80–100

Servicing the hydraulic system

Hydraulic oil pump

A hydraulic pump generates hydraulic flow to operate the intensifier. The pump is connected directly to an electric motor by a flexible coupling. The pump does not need routine maintenance.

Problems associated with the pump are leaks, noise, metallic debris in the hydraulic oil, and erratic or low oil pressure. These problems are addressed in the following procedures:

- Replacing the hydraulic pump
- Cleaning a contaminated hydraulic system
- Checking the hydraulic oil
- Changing the hydraulic oil
- Replacing the hydraulic oil filter

CAUTION

The hydraulic pump is specially modified and tested for this application. Do not use a substitute pump.

Note: The compensation override control valve(s) is set at the factory and never needs adjustment. If a new pump is installed, contact Flow Technical Service.

Replacing the hydraulic pump

Replace the hydraulic pump if:

- system oil pressure is abnormally low
- pump operation is unstable
- pump is excessively noisy

Expect oil spillage with this service. When factory floor drains must be oil-free, install a barrier to block oil. Limit oil spillage by using drip pans, plugging each line and port, and allowing a generous drip time.

CAUTION

If replacing the hydraulic pump because a catastrophic hydraulic pump failure contaminated the hydraulic oil system, see *Cleaning a contaminated oil system*.

Service steps

WARNING

Place the main electrical disconnect in the OFF position and bleed down all high-pressure lines. Place an *Out of Service* tag on the main electrical disconnect and lock it out. Failure to do so can result in equipment damage or injury to personnel.

1. Shut down the system.
2. Drain the reservoir.

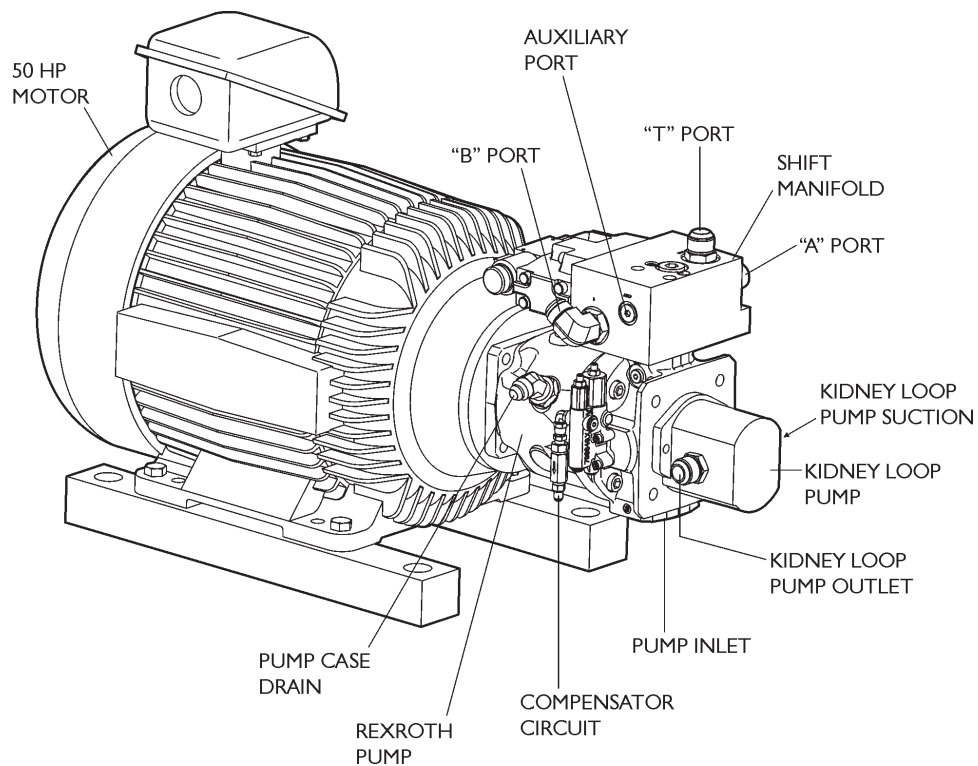

3. Loosen the suction line at the lowest point to drain oil from the line and pump.
4. Remove the compensator line. Plug the line and secure it out of the way.
5. Remove the system pressure line. Plug and secure the line.
6. Remove the pump control drain or case drain line. Plug and secure the line.
7. Remove the suction and discharge hoses from the kidney loop pump. Remove the kidney loop pump.
8. Support the pump so it can be pulled away from the motor. Be careful when handling the pump—it can weigh more than 150 lb (68 kg). Use blocks or jacks to support the pump, or use a forklift.
9. Remove the two screws that mount the pump to the electric motor.
10. Carefully move the pump and adapter away from the frame and set it on end, pump side down.
Note: If installing a new pump, transfer all fittings, including the bypass manifold, to the new pump.
11. Move the new pump up to the motor. Make sure the coupling is in place.
12. Attach the pump to the electric motor with the two screws.
13. Connect the compensator, case drain, system pressure, and suction lines. Make sure the lines are not twisted and all fittings are correctly oriented to minimize stress on the lines. Lubricate the o-rings with Parker Super O Ring Lube or clean hydraulic oil.
14. Clear away all tools, parts, and rags.
15. Fill the hydraulic oil reservoir until oil is visible in the sight gauge (recommended oils are listed on page 6).
16. Run the pump at low pressure for 3–5 minutes while checking for leaks. Increase the pressure to high pressure; continue checking for leaks.
17. Operate the pump an additional 7–10 minutes.
18. Check the oil level in the sight gauge and add oil as needed.

If all work is satisfactory, shut down the pump. Remove tools, parts, and rags from the equipment. Remove the *Out of Service* tag from the main electrical disconnect. The pump can be returned to operation.

CAUTION

You must add oil to the reservoir AND the hydraulic pump case before operating the pump or you will SEVERELY damage the system.

Cleaning a contaminated hydraulic system

When the hydraulic pump is being replaced because of a catastrophic failure (indicated by the presence of metal flakes throughout the hydraulic oil system), you must completely clean the hydraulic system. If you do not, the new pump, intensifier, shift valve, pilot valve, pressure control valve, and other components can fail.

Service steps

WARNING
Place the main electrical disconnect in the OFF position and bleed down all high-pressure lines. Place an *Out of Service* tag on the main electrical disconnect and lock it out. Failure to do so can result in equipment damage or injury to personnel.

1. Shut down the system.
2. Follow the procedures below for each pump component, then continue with Step 3.

Reservoir

- Drain the contaminated oil from the reservoir.
- Remove the cover from the reservoir and completely clean the interior.

Hoses

- Remove ALL hydraulic oil hoses: case drain, suction, bypass drain, system pressure, compensator, pressure control valve manifold, and bleed-down valve system. Pour fresh oil through all loose lines (hoses) to clean and flush out the old oil.

Hydraulic pump(s)

- Remove the shift valves, pilot valves, relief valves, and manifolds. Completely clean and flush with fresh oil or cleaning solvent.

Heat exchanger

- Remove the heat exchanger and test it for leaks (see *Servicing the heat exchanger*). If the heat exchanger does not leak, flush it with fresh oil. If the heat exchanger is faulty, replace it.

Note: Before installing a new heat exchanger, test it for leaks as described in *Servicing the heat exchanger*.

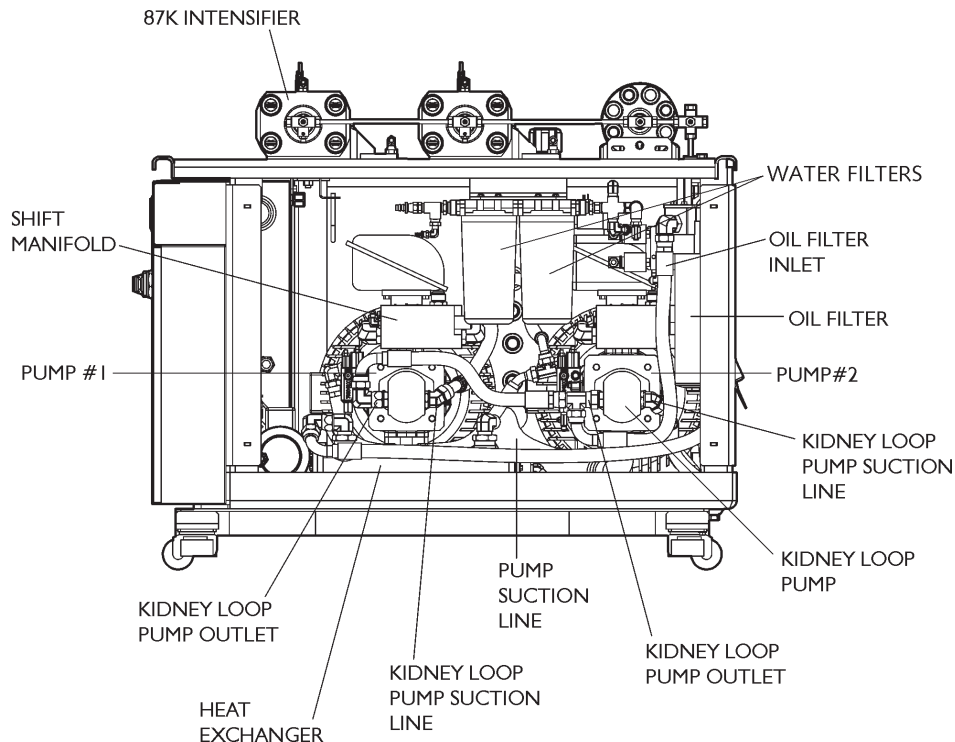

Oil filter

- Remove the oil filter and discard. Thoroughly clean the housing and install a new filter.

Intensifiers

- Remove the intensifier(s) from the frame.
- Completely disassemble the intensifier. Inspect for seal failure and replace parts as needed. Completely clean the intensifier. Refer to your intensifier manual for instructions.

Service continues

3. Reassemble the hydraulic system.
4. Fill the hydraulic oil reservoir until oil is visible in the sight gauge (recommended oils are listed in Chapter 1).

CAUTION

You must add oil to the reservoir AND the hydraulic pump case(s) before operating the pump or you will SEVERELY damage the system.

5. Operate the pump at low pressure 3–5 minutes while checking for leaks. Increase the pressure to high pressure; continue checking for leaks.

Note: After servicing the hydraulic system, the oil level may be low. Check the reservoir oil level and add oil as needed.

6. After operating the pump for 7–10 minutes and all work is satisfactory, shut down the pump.

Remove tools, parts, and rags from the equipment. Remove the *Out of Service* tag from the main electrical disconnect. The pump can be returned to operation.

After operating the pump with fresh oil for 10–20 hours, drain the reservoir and refill with fresh hydraulic oil. Replace the oil filter.

Checking the hydraulic oil

Check the hydraulic oil:

- after a specific number of operating hours
- at the end of a specific time period
- if the oil becomes contaminated
- when you replace the hydraulic pump.

Refer to MS-2258 for recommended service intervals.

Service steps

1. Open the drain valve on the bottom of the tank. Drain the oil into a clear beaker until you see pure oil, then close the drain valve. Place the beaker on a level surface and let the oil settle for at least 10 minutes.
2. Check the beaker. If the beaker only contains oil, you do not have a condensation problem. If you see hydraulic oil floating on a layer of water, the reservoir contains condensation from air drawn into it as the oil cools.
 - If there is more than 200 ml of water in the beaker, drain the water from the reservoir at least every 2 to 3 weeks to keep the monthly condensation level less than 200 ml. See *Changing the hydraulic oil*.
 - If the oil looks milky, there could be an excessive amount of water in the oil. Make sure the oil filler cap is in place. Check the heat exchanger for leaks. Fix any problems and change the oil before operating the pump.
 - If the oil has a burned color or smell, or if there is debris in the oil sample, additional service work is required. See *Servicing the hydraulic pump* for more information.

Changing the hydraulic oil

This is the accepted procedure for changing hydraulic oil. Your oil supplier can tell you how to properly dispose of used hydraulic oil.

Service steps

WARNING

Place the main electrical disconnect in the OFF position and bleed down all high-pressure lines. Place an *Out of Service* tag on the main electrical disconnect and lock it out. Failure to do so can result in equipment damage or injury to personnel.

1. Shut down the system.
2. Use a hose to drain the oil from the reservoir drain valve into a container large enough to hold 37 gal (140 L).
3. Remove the access cover from the reservoir and thoroughly wipe clean the inside surfaces of the reservoir.
 - If the oil was contaminated with metal particles because of a pump or hydraulic piston failure, see *Cleaning a contaminated oil system*.

CAUTION

You must thoroughly clean the reservoir after metal flakes have been pumped through it or the pump, intensifier, shift valve, pilot valve, shift cables, pressure control valves, and other components can fail. Your warranty does not cover this damage.

4. Change the hydraulic oil filter. See *Replacing the hydraulic oil filter*.

HyperJet 94i-S reservoir

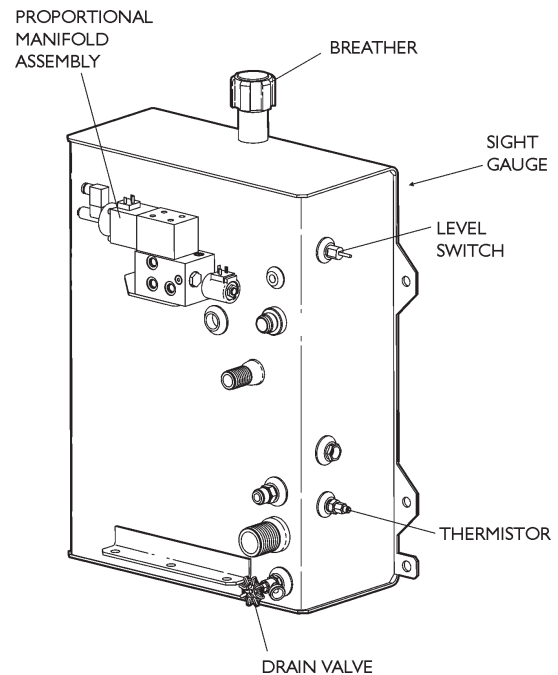

HyperJet 94i-D reservoir

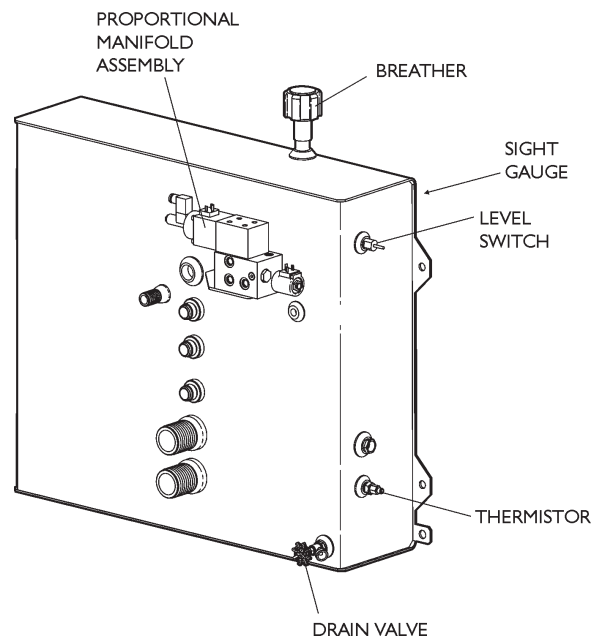

5. Close the drain valve and refill the reservoir with fresh hydraulic oil until the level is visible on the sight gauge.
 - Reservoir capacity is listed on Page 32.Use an oil that does not contain anti-wear additives; recommended oils are listed in Chapter 1.

6. Start the pump, operate it for 3–5 minutes at high pressure, and check for leaks. Check the reservoir oil level; add oil as needed.

When all work is satisfactory, remove tools, parts, and rags from the pump and close the doors. Remove the *Out of Service* tag from the main electrical disconnect.

Replacing the kidney loop oil filter

Replace the hydraulic oil filter:

- if the restriction indicator has actuated
- after a specific number of operating hours
- after a specific length of time
- when you change the hydraulic oil

Service steps

WARNING

Place the main electrical disconnect in the OFF position and bleed down all high-pressure lines. Place an *Out of Service* tag on the main electrical disconnect and lock it out. Failure to do so can result in equipment damage or injury to personnel.

1. Shut down the system.
2. Locate the oil filter housing within the pump frame.
3. Place a drip pan under the housing.
4. Unscrew the filter bowl from the filter head. Drain the oil from the bowl into the drip pan.
5. Gently pull and turn the filter element to remove it from the housing head, and place it in a drip pan. Inspect the element and bowl for visible dirt or particles—this can give early warning of component failure.
6. Clean out the bowl and the filter housing and insert a new element.
7. Lubricate the new element o-ring with clean hydraulic oil and install in the housing head.

8. Raise the bowl into position to engage the threads. Thread the bowl into the filter head until it is firmly seated.
9. Operate the pump for 3–5 minutes at the maximum rated pressure. Check for leaks.

When all work is satisfactory, remove tools, parts, and rags from the pump and close the cover. Remove the *Out of Service* tag from the main electrical disconnect.

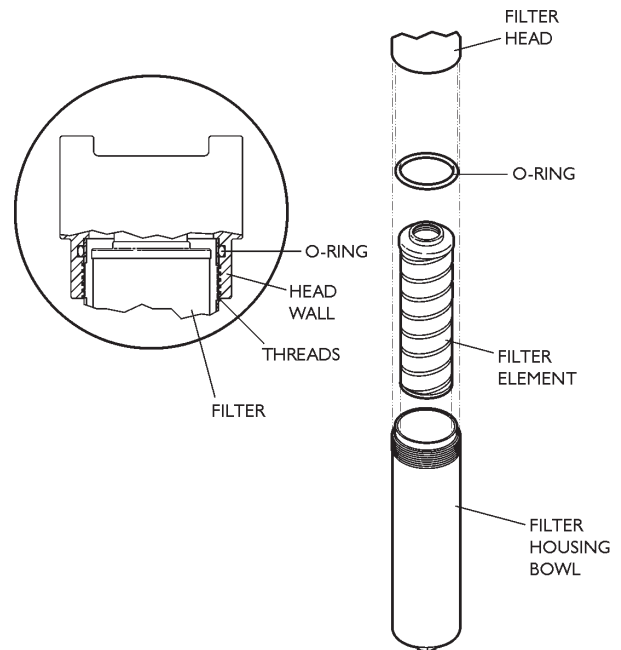

Servicing the heat exchanger

This service procedure is a test to see if the heat exchanger is leaking water into the oil system. The oil-to-water heat exchanger controls heat build-up in the hydraulic oil. The heat exchanger requires no routine maintenance.

If the hydraulic oil looks milky but doesn't contain air bubbles, the oil is contaminated with water. This can be caused by contaminated oil in the reservoir, excessive condensation in the reservoir, a missing reservoir filler cap, or a leaky heat exchanger.

Note: A continual rise in oil level is a sign of catastrophic heat exchanger failure.

Service steps

WARNING

Place the main electrical disconnect in the OFF position and bleed down all high-pressure lines. Place an *Out of Service* tag on the main electrical disconnect and lock it out. Failure to do so can result in equipment damage or injury to personnel.

1. Shut down the system.
2. Drain the contaminated oil from the reservoir. If you see a large amount of water in the oil, the hydraulic oil system must be completely drained to remove all water, including intensifier, hydraulic pump, filter, and hoses.

See *Checking the hydraulic oil* and *Cleaning a contaminated hydraulic system*.

3. Disconnect the water hoses from the heat exchanger.

4. Disconnect and plug the hydraulic oil lines. Hold the heat exchanger level, and use a drip pan and rags to catch dripping oil.
5. Remove the bolts that hold the heat exchanger to the support and move the heat exchanger to a workbench.
6. Plug one of the water ports and insert an air line fitting into the other.
7. Top off the oil level in the heat exchanger.
8. Connect an air line to the fitting. The air line must be regulated to a maximum of 150 psig (10.3 bar) air pressure, and have an on/off valve within easy reach.
9. Watch the oil ports for air bubbles while slowly opening the air valve and pressurizing the heat exchanger. If the heat exchanger is leaking, you'll see bubbles within a few seconds.
 - If the heat exchanger is defective, repair or replace it.
 - If the heat exchanger is OK, remove the fittings and reinstall the heat exchanger.
 - Repeat Steps 3 through 9 for the second heat exchanger.
 - If the heat exchanger is OK, water in the oil was probably caused by putting contaminated oil into the reservoir, excessive condensation in the reservoir, or a missing reservoir filler cap. See *Checking the hydraulic oil*.
10. Fill the hydraulic oil reservoir until oil is visible in the sight gauge (see Chapter 1 for a list of recommended oils).

CAUTION

You must add oil to the reservoir AND hydraulic pump case before operating the pump or you will SEVERELY damage the system.

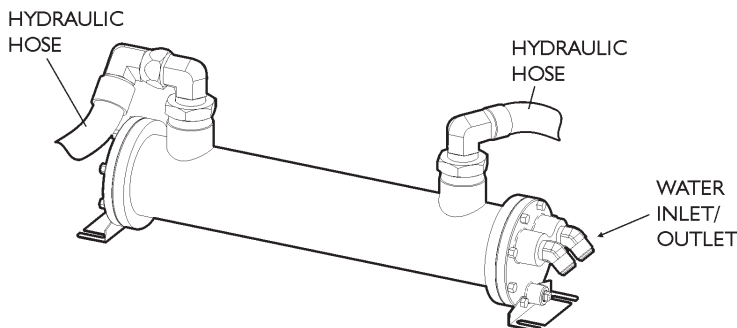

Servicing the bleed-down valve

This service procedure is for bleed-down valve 019309-1. You will need the 015084-1 bleed-down valve repair kit.

Troubleshooting

Problem	Cause
Unable to build water pressure* High stroke rate Hard shifting Water leaking from weep holes	High-pressure valve failure
Oil leaking from weep holes	Actuator failure
Unable to build water pressure*	Solenoid valve failure

* Lack of water pressure is more likely caused by high-pressure valve failure than by solenoid valve failure.

Service steps

WARNING
Place the main electrical disconnect in the OFF position and bleed down all high-pressure lines. Place an *Out of Service* tag on the main electrical disconnect and lock it out. Failure to do so may result in equipment damage or injury to personnel.

Note: Make notes or sketches of the location and orientation of all components during disassembly to use as a guide for reassembly later.

1. Remove the hydraulic hose from the oil port of the bleed-down valve.
2. Remove the gland nut that connects the water drain tubing to the bleed-down valve.
3. Remove the gland nut from the high-pressure water inlet port of the valve main body. Remove the high-pressure water pressure sensor from the valve body.
4. Remove the valve from the pump bracket and place it on a clean workbench.

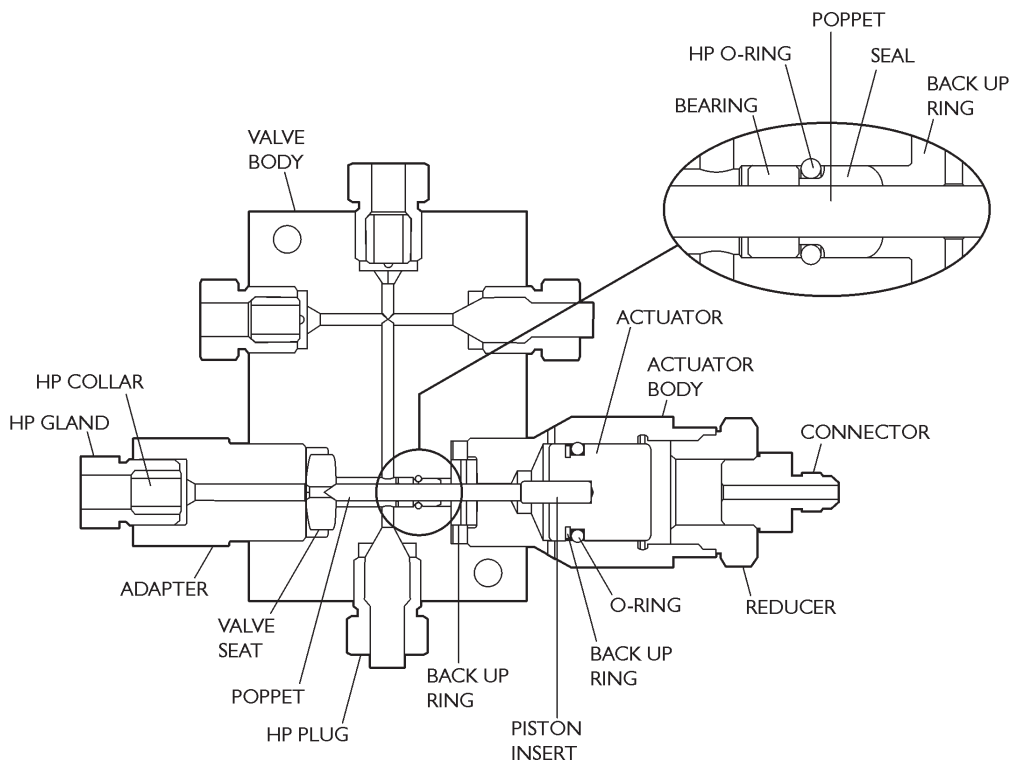

5. Separate the actuator body from the high-pressure valve.
 6. Remove the adapter from the high-pressure body.
 7. Remove and discard the high-pressure seat.
 8. Remove and discard the high-pressure seal assembly (poppet, seal, back-up ring, o-ring, and bearing).
 9. Remove the oil port adapter and use a $\frac{3}{16}$ -in. dowel (or similar) to push the piston insert and piston out of the actuator body through the oil port.
 10. Remove and discard the o-ring and back-up ring from the piston.
 11. Clean the remaining parts in an ultrasonic cleaner. Check the parts for nicks and burrs; replace as necessary.
 12. Lubricate a new o-ring, back-up ring, and the inner surface of the actuator body with Parker Super O Ring Lube or equivalent.
 13. Install the new o-ring and back-up ring on the actuator piston with the back-up ring towards the insert end of the piston. Install the insert into the piston, then install the piston assembly into the actuator body until seated.
Note: Avoid damaging the o-ring on the threads and inside corners of the actuator body.
 14. Replace the oil port adapter in the actuator body.
 15. Lubricate the poppet, seal, o-ring, and bearing with White Food Grade O Ring Lube.
 16. Install the o-ring onto the high-pressure seal and then install the seal onto the poppet with the o-ring towards the pointed end of the poppet.
 17. Install the new bearing and back-up ring onto the poppet with the bearing on the pointed end side and the back-up ring on the opposite side of the seal. Then insert the assembly into the high-pressure body through the actuator port (largest diameter thread).
 18. Push the back-up ring down until seated against the flat bottom of the port.
 19. Install the high-pressure seat in the high-pressure body, applying Blue Lubricant to mating surfaces.
Note: The seat is symmetrical and either face may be inserted first.
 20. Apply blue lubricant to the threads, then install the adapter into the valve body. Torque to 125 ft-lb (170 N-m).
 21. Thread the actuator body into the high-pressure valve assembly and tighten.
 22. Reinstall the bleed-down valve on the pump bracket and insert the gland nut in the high-pressure inlet port in the side of the valve. Torque the gland nut to 35 ft-lb (47 N-m).
 23. Install the gland nut that connects the water drain tubing to the bleed-down valve, and reinstall the high-pressure water pressure sensor.
 24. Reattach the hydraulic hose to the oil port of the bleed-down valve.
- Return the intensifier pump to operation. Correct any water or oil leaks.

Replacing the booster pump

Service steps

WARNING

Place the main electrical disconnect in the OFF position and bleed down all high-pressure lines. Place an *Out of Service* tag on the main electrical disconnect and lock it out. Failure to do so can result in equipment damage or injury to personnel.

1. Shut down the system.
2. Disconnect the water hoses from the booster pump.
3. Remove the hard plumbing fittings from the booster pump and transfer to the new pump.
4. Mark and remove the wiring from the booster pump motor junction box.
5. Unfasten the booster pump/motor assembly from the baseplate and install the new assembly.
6. Reconnect the wiring and water hoses.

Remove tools, parts, and rags from around the pump. Remove the *Out of Service* tag from the main electrical disconnect. Run the pump for 5 minutes and check for correct operation.

HyperJet 94i-S booster pump

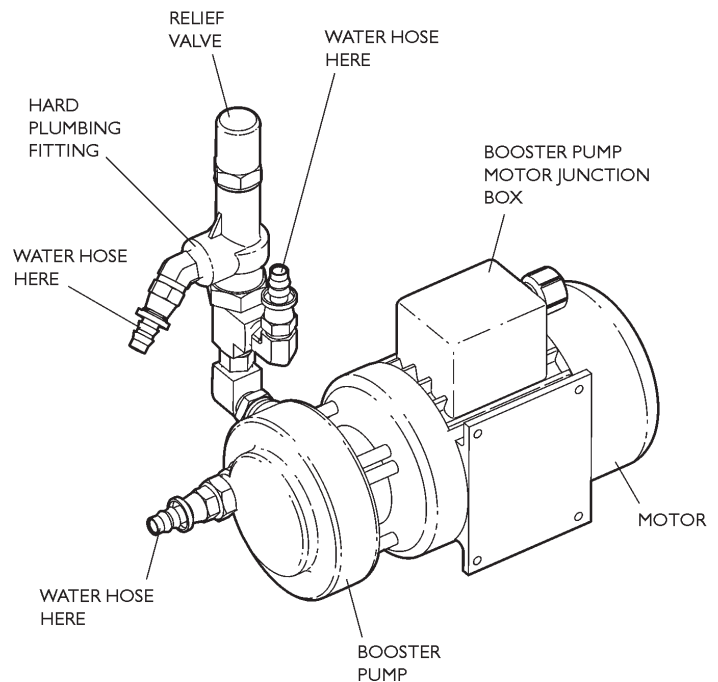

HyperJet 94i-D booster pump

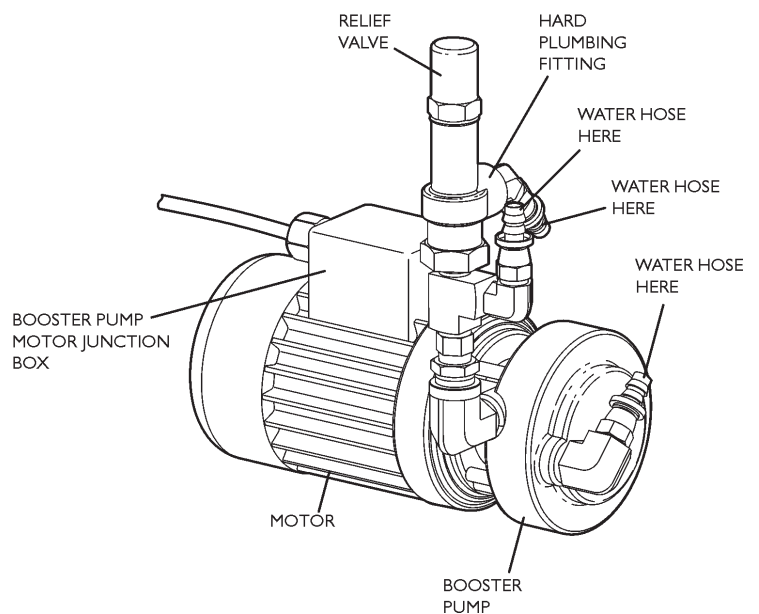

Replacing the filter elements

Replace the filter elements if the pressure difference between the inlet and outlet exceeds 20 psig (1.4 bar) or after six months of operation, whichever occurs first.

Service steps

1. Close the inlet valve for the filter bank.
2. Unscrew the filter bowls slightly to relieve pressure.

Notes

- If you can't remove bowls by hand, use a strap or band wrench at the top of the bowl *only*. Avoid excessive pressure to the side of the bowl.
 - A small amount of water will spill when the filter bowls are removed. A shallow drip pan under the filter will minimize clean-up.
3. Remove the filter bowl and elements together. Remove and discard the filter elements. Inspect the contents of the bowls. A change in water quality, pump housing, or impeller deterioration, or a missing or damaged upstream filter, can sometimes be detected early by inspecting the filter bowls and elements.
 4. Clean the bowls and fill with fresh water.
Install the new elements in the bowls, and then install on the filter heads. Seal rings, provided with the elements, seal the elements to the heads. Lubricate the rings with food-grade grease. Make sure the filter elements are installed on the correct filter heads; look for the markings to make sure.
 5. Make sure the seal ring is in place, then tighten each bowl hand tight on the filter bank head.
 6. Open the inlet valve. Check for leaks. Bleed air from the filters using the bleed valve.
 7. Run the intensifier pump for 5 minutes at low pressure with the cutting nozzle open to purge any air from the system. Failure to do so could damage the high-pressure seals.

HyperJet 94i-S water filter

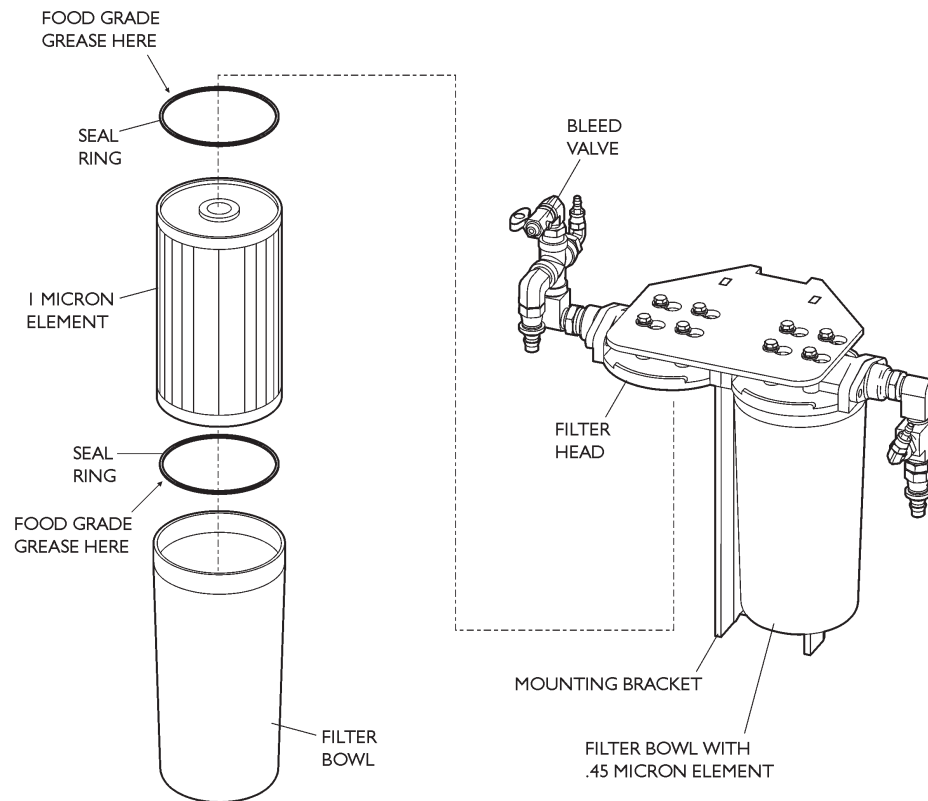

HyperJet 94i-D water filter

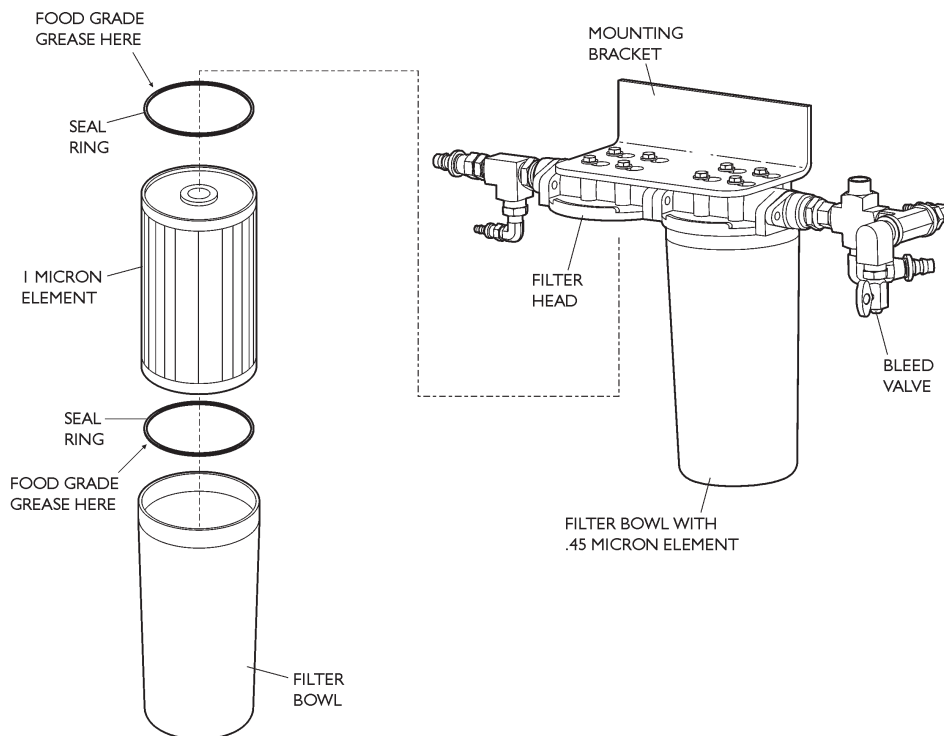

Servicing the shift valve manifold assembly

Each manifold assembly contains the following components:

- Pilot valve
- Shift valve
- Main system relief valve
- Manifold body

This section contains service procedures for these components. Intensifier service procedures are located in your intensifier manual.

The manifold assembly and its component parts require no routine maintenance.

All operations require the reservoir to be drained.

How it works

Hydraulic oil is supplied at pressure to the manifold body from the associated main hydraulic pump. The shift valve distributes the flow of oil through the manifold to each end of the intensifier low-pressure cylinder in turn, as required. The shift valve directs the return flow of oil from the other end of the intensifier to the reservoir via the return port of the manifold at the same time.

The shift valve is operated hydraulically by a pilot valve mounted above it. The pilot valve is operated by two solenoid coils controlled by the integrated shift module. This module receives its timing signals from the shift sensor assemblies in the intensifier end bells, which directly sense the presence of the intensifier piston as it comes to the end of its stroke at each end bell in turn.

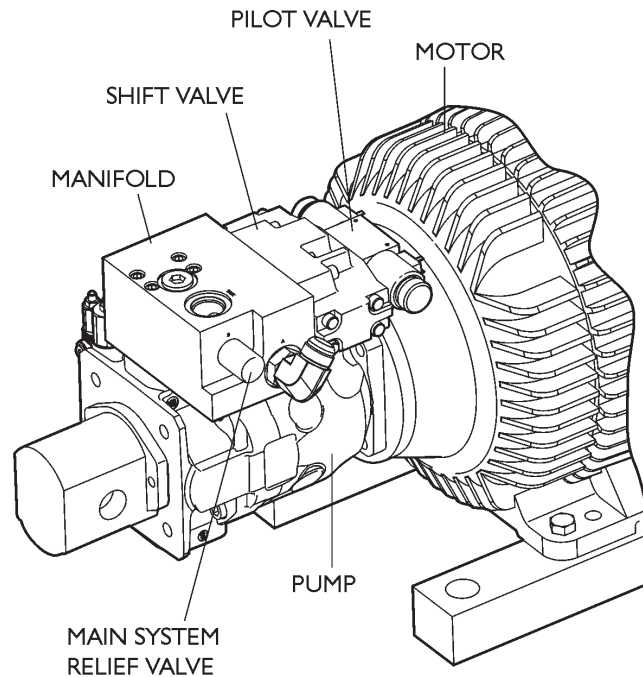

Replacing a complete intensifier assembly

The intensifier assembly can be removed from the pump frame as a single unit. This is useful if the intensifier has failed, if there is an exchange intensifier assembly ready to be installed, and if pump operation cannot be interrupted long enough to repair the intensifier in place on the pump frame.

Removing the intensifier assembly

WARNING

Place the main electrical disconnects in the OFF position and bleed down all high-pressure lines. Place Out of Service tags on the main electrical disconnects and lock them. Failure to do so can result in equipment damage or injury to personnel.

1. Shut down the system. Close the external inlet filtered water hand valve, where installed.
2. Disconnect the inlet water supply hoses at both intensifier end caps.
3. Disconnect and remove the high-pressure tubing assemblies from the intensifier.
4. Disconnect the shift sensor cables from the shift module extension cables.
5. Place absorbent pads under and around the hydraulic hose connections to the intensifier manifold. Disconnect the two hoses from each the intensifier end bells. Install caps in the end bells to reduce oil spillage.
6. Remove the two screws ($1\frac{5}{16}$ -in. A/F) that hold the intensifier and base plate to the pump frame.
7. Using suitable lifting equipment, remove the complete assembly from the pump frame.

Note: The intensifier assembly weighs 265 lb (120 kg).

Reinstalling the assembly

1. Using suitable lifting equipment, lower the intensifier assembly into place on the pump frame.
 2. Replace the two screws that hold down the base plate.
 3. Remove the caps from the end bells; make sure the hose flange o-rings are in place, then connect the hoses and tighten the hose flange clamps screws.
 4. Connect the shift sensor cables to the intensifier shift module.
 5. Install and connect the high-pressure tubing assemblies to the intensifier.
 6. Connect the inlet water supply hoses at both intensifier end caps.
 7. Verify that the intensifier assembly is complete, that shift sensors are in place, and that fasteners are properly tightened.
 8. Open the external filtered water inlet hand valve, if installed.
 9. Remove the *Out of Service* tags from the main electrical disconnects.
- Note:** Air will be automatically purged from the intensifier assembly on next start-up of the pump unit as it refills the intensifier and manifold. This will cause the oil level to drop. Check the oil level in the reservoir sight gauge and add fresh oil until the level is at the high mark.
10. Run the pump unit at low pressure for 3–5 minutes while checking for leaks.

Remove tools, parts and rags from the pump unit. The pump unit is ready for operation.

Integrated shift module

The integrated shift module is mounted in the pump's front panel. The electronics board is permanently sealed in the module to prevent damage and is not a serviceable component.

When viewed from the face with the bracket, with the bracket up, the electrical connections are as follows:

Connector location	Connects to
Top left	Shift module cable
Top right	Pilot valve solenoid coils double connector cable (cable is on the right-hand side of the pilot valve)
Bottom left	Left hand side shift sensor cable
Bottom right	Right hand side shift sensor cable

LED indicator lights on the top of the module indicate the operation of the circuit.

- A green LED lights up when the shift sensor on the same side is energized by the intensifier piston
- A red LED lights up when the pilot valve solenoid coil on the same side is energized

CAUTION

At no time should both LEDs of the same color be lit. If both red LEDs are lit together, there is an internal fault in the module and it must be replaced. If both green LEDs are lit together, there may be an internal fault in the module or a fault with either shift sensor assembly. See *Shift sensor assembly* for instructions.

Use the troubleshooting tips in *Shift sensor assembly* to identify whether a shifting problem exists in the sensor assemblies or in the shift module. If both shift sensor assemblies are known to be working correctly, there is an internal fault in the module and it must be replaced.

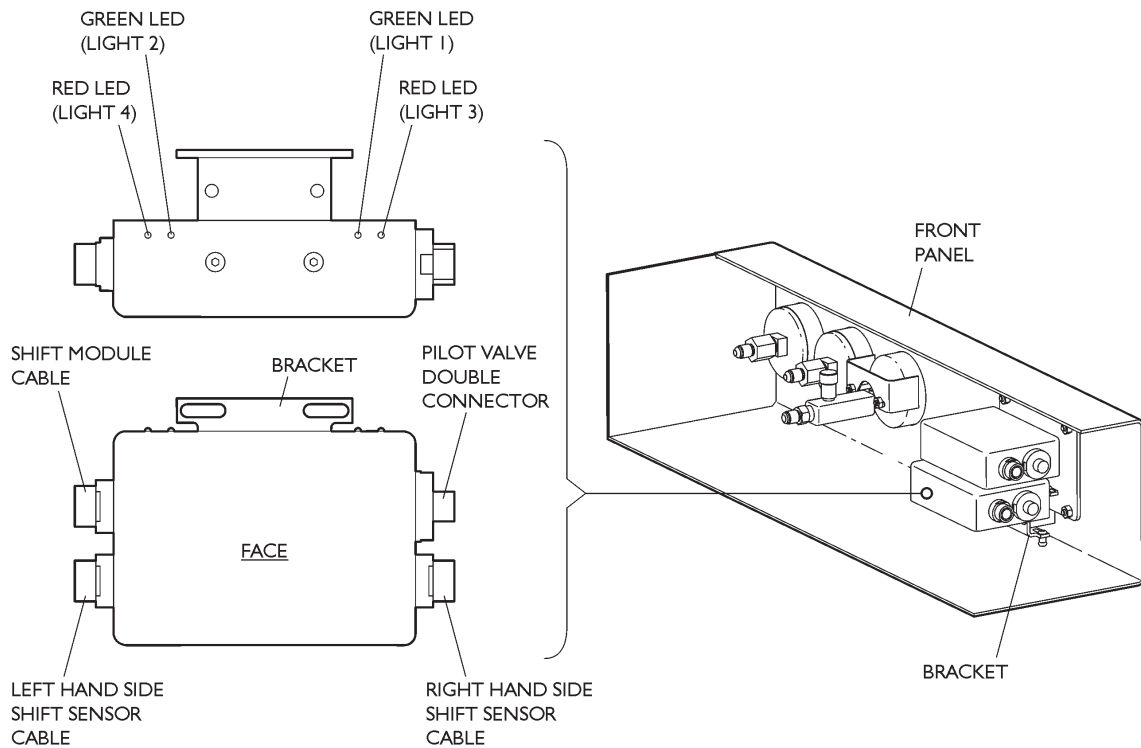

Testing the shift module

A useful troubleshooting technique to identify whether a problem is in the shift module or in one or both shift sensors is to operate the intensifier with external “test” shift sensors.

WARNING

Do not start the pump unit unless all shift sensors are in place on ALL end bells. Starting the intensifier pump with shift sensors removed can result in equipment damage or injury to personnel.

When the pump is operating, the manifold assembly can contain up to 3500 psi (241 bar) oil pressure. NEVER start or operate the pump when any of the manifold assembly parts are loose or removed.

Test procedure

1. Stop the pump, but do not shut down the system.
2. Disconnect the shift sensor cables at the connections in the cable extensions, close to the intensifier, leaving the shift sensors in place in their end bells.
3. Get two sensors that you know to be good and connect their cables to the shift module cable extensions. These become the test shift sensors.
4. Check that the intensifier is enabled at the press system control panel and start the pump at low pressure.
5. Insert the magnet end of a spare actuating plunger into the cupped end of each of the two test sensors in turn. The intensifier should stroke and shift each time the magnet is inserted. The green LED on the shift module should light up when the magnet is inserted. The red LEDs should light up and stay lit in turn until the opposite shift sensor switches them.
6. Shut the pump down. Remove the test shift sensors and re-connect the intensifier shift sensors to the shift module.

If the module does not operate as described it may need replacing.

Pilot valve

The pilot valve is electrically operated by two solenoid coils, which are energized by the integrated shift module. Oil from the pilot valve is used to cycle the shift valve spool, which in turn causes the intensifier to cycle. Each solenoid coil connector LED lights up when that solenoid coil is energized.

The most common pilot valve problems are leaks due to worn o-rings, a failed solenoid coil, and sticking of the spool in the body due to contaminated oil. See *Cleaning a contaminated hydraulic system*.

Service steps

WARNING

Place the main electrical disconnects in the OFF position and bleed down all high-pressure lines. Place *Out of Service* tags on the main electrical disconnects and lock them out. Failure to do so can result in equipment damage or injury to personnel.

1. Shut down the system.

Note: When working on the valves, drain the oil from the reservoir into a clean container able to hold 37 gallons (140 L).

2. Remove the solenoid coil connectors by unscrewing their central screws and unplugging the connector bodies from the solenoid coils.

- Check solenoid coil continuity using an ohmmeter across the two channel-shaped pins. Electric resistance should be approximately 19 ohms. The third, flat pin is the ground connection.

3. Remove each solenoid coil by unscrewing the large black knob, removing the o-ring, and sliding the solenoid coil off its core.

4. Unscrew each core using a wrench on the two flats close to the valve body ($\frac{3}{4}$ in./19 mm A/F). Inspect the core o-ring for damage.

Remove the spring and notched washer uncovered on each side.

5. With a finger on each end of the pilot valve spool, slide the spool from side to side. The spool must move smoothly through its full stroke. If the spool catches or is jammed, you must replace the pilot valve.

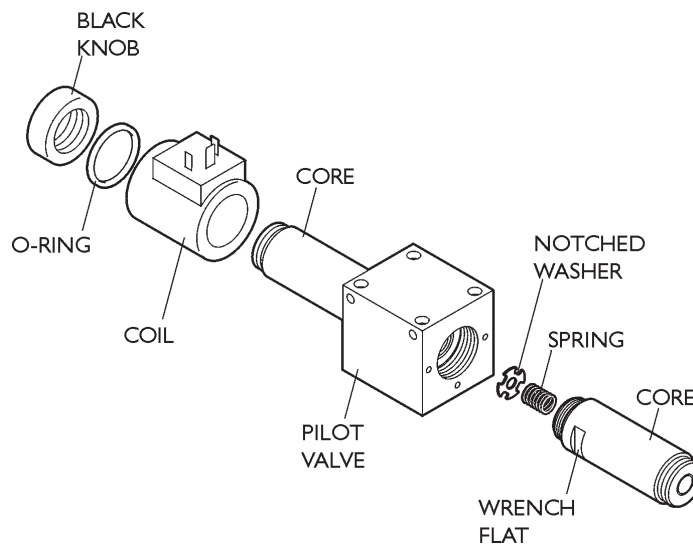

- Remove the pilot valve body by unscrewing the four cap screws ($\frac{5}{32}$ in. socket) in a figure-8 pattern in $\frac{1}{8}$ -turn increments until all torque has been removed.

Lift the pilot valve from the main shift valve. Inspect the interface sealing rings and replace as necessary.

Note: The pilot valve is oriented on the shift valve end-for-end and must be replaced in the same orientation. To help with realignment, the letter “P” on the pilot valve body corresponds with a “P” on the shift valve body, and the screws on one end of the pilot valve body are closer together than those on the other end.

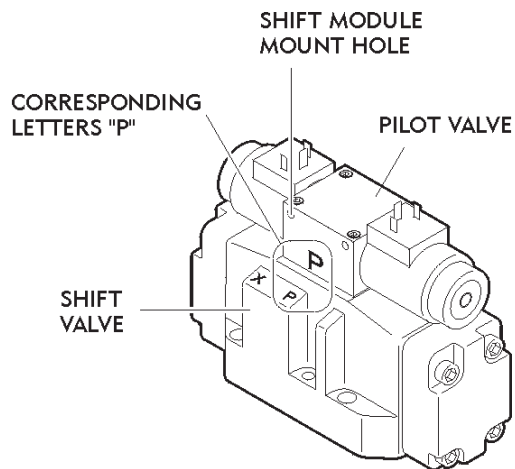

- Lubricate new sealing rings with Parker Super O-ring Lube (200006) and place in the ports of the pilot valve.
- Place the pilot valve onto the shift valve in the same orientation as noted in Step 6 and screw in the fasteners. Torque in a figure-8 pattern in $\frac{1}{8}$ -turn increments to 6.5 ft-lb (8.9 N-m). Make sure the spool moves smoothly.

- Insert the notched washer in its locating groove in one end of the body and the spring in one solenoid core. Screw the solenoid core into the pilot valve body; being careful not to nick the o-ring. Tighten with a wrench.

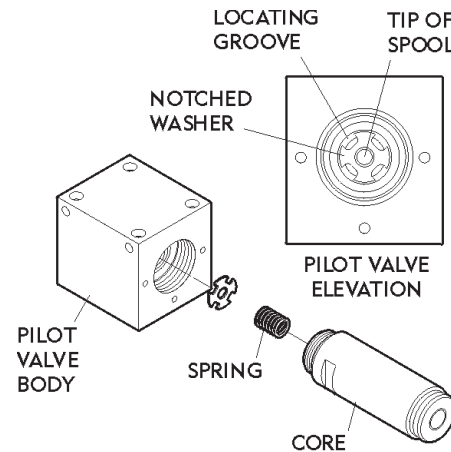

Repeat this step on the other end of the body.

- Install the solenoid coils onto their cores, making sure the locating pin on the solenoid coil end face engages the hole in the valve body, and that the solenoid coil connector is correctly oriented.

Place the o-rings on the cores and screw on the retaining knobs hand tight.

- Reconnect the solenoid coil connectors and tighten the screws. Make sure that the cable of the connectors is on the right-hand side when viewed from the front of the intensifier (i.e., with the intensifier manifold behind the intensifier.)

If the reservoir was drained in Step 1, refill the reservoir.

- Remove the *Out of Service* tags from the main electrical disconnects.
- Run the pump unit at low pressure for 3–5 minutes while checking for leaks. Remove tools, parts and rags from the pump unit. The pump unit is ready for operation.

Note: This service procedure introduces a small amount of air into the hydraulic system which will purge automatically on pump unit start-up.

Shift valve

The most common shift valve problems are leaks due to worn o-rings and sticking of the spool in the body due to contaminated oil. See *Cleaning a contaminated hydraulic system*.

Service steps

1. Shut down the system.

WARNING

The shift valve is specially modified for this application. Using a substitute shift valve can create a potential safety hazard, will lower the performance of your pump and void your warranty.

Place the main electrical disconnects in the OFF position and bleed down all high-pressure lines. Place *Out of Service* tags on the main electrical disconnects and lock them out. Failure to do so can result in equipment damage or injury to personnel.

When the pump is operating, the manifold assembly can contain up to 3500 psi (241 bar) oil pressure. NEVER start or operate the pump when any of the manifold assembly parts are loose or removed.

Note: When working on the shift valves, drain the oil from the reservoir into a clean container able to hold 37 gallons (140 L).

2. Remove the pilot valve by unscrewing the four cap screws ($\frac{5}{32}$ -in. socket) in a figure-8 pattern in $\frac{1}{8}$ -turn increments until all torque has been removed. Set the valve aside.

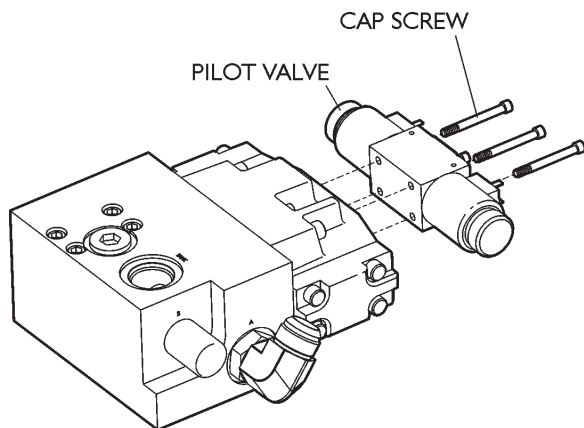

3. Remove the four cap screws (6 mm socket) that hold each shift valve end cap in place; remove the end caps.

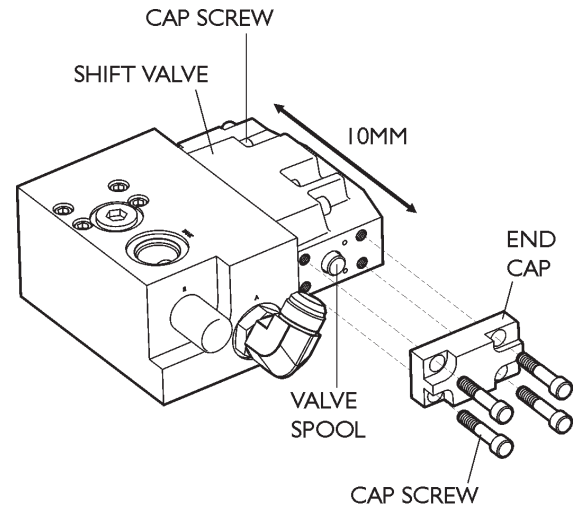

4. Use your fingers to make sure the shift valve spool moves freely in the valve body. The spool must move with light pressure through its full stroke of 10 mm.
5. Remove the spool and make sure the spool grooves are clean and the polished surfaces are undamaged. Check the inside of the shift valve body for any damage or foreign objects. Inspect the end cap o-rings for damage and replace as necessary.
6. Loosen the cap screws (4 screws with $\frac{5}{16}$ in. socket and two with $\frac{3}{16}$ in.) on the shift valve in $\frac{1}{8}$ -turn increments until all torque is removed. Remove the shift valve body from the manifold.

7. Inspect the o-rings for wear and replace as necessary. Lubricate the o-rings with Parker Super O Ring Lube and insert them in the shift valve.

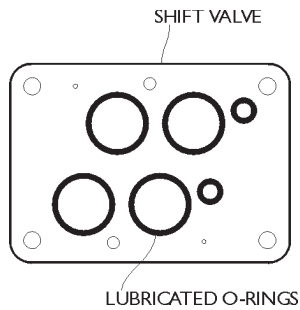

8. Place the shift valve body on the manifold so that the offset ports in the shift valve match those in the manifold. Thread in the cap screws.
9. Torque the cap screws in $\frac{1}{8}$ -turn increments in this two step process:
 - a. Torque all cap screws (in the order 1 to 6, as shown) to 11.5 ft-lb (15.6 N-m).
 - b. Torque the outer cap screws (in the order 1 to 4, as shown) to 55 ft-lb (74.5 N-m).

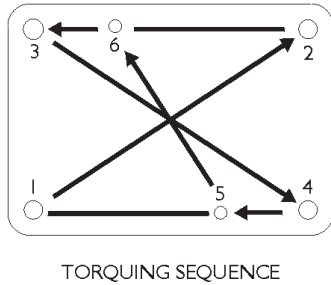

10. Use your fingers to make sure the spool moves freely.
11. Lubricate the end cap o-rings with Parker Super O Ring Lube and install in the end caps. Install the end caps on the shift valve body. Torque the cap screws to 30 ft-lb (40.7 N-m).

12. Install the pilot valve (see *Pilot valve*).

Note: If the reservoir was drained in Step 1, refill the reservoir.

13. Remove the *Out of Service* tags from the main electrical disconnects.

Note: This service procedure introduces a small amount of air into the hydraulic system, which will purge automatically on pump unit start-up.

14. Run the pump unit at low pressure for 3–5 minutes while checking for leaks. Remove tools, parts and rags from the pump unit.

The pump unit is ready for operation.

Main system relief valve

A main system relief valve is mounted in each shift valve manifold. The valve is a mechanical way to safely limit maximum hydraulic oil pressure in the unlikely event of multiple component failure. Since the relief valve opens at a value higher than the maximum system working pressure, it remains closed during operation.

The valve needs no routine maintenance, and should be replaced only if it bypasses oil below the maximum system working pressure. If you have questions about the relief valve, contact FLOW Technical Service.

Replacing the main system relief valve

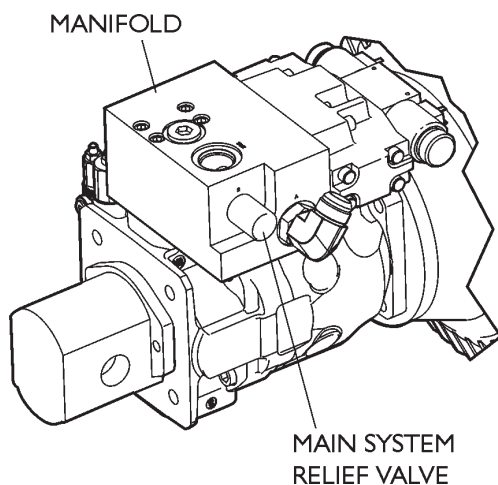

WARNING

Place the main electrical disconnects in the OFF position and bleed down all high-pressure lines. Place *Out of Service* tags on the main electrical disconnects and lock them out. Failure to do so can result in equipment damage or injury to personnel.

When the pump is operating, the manifold assembly can contain up to 3500 psi (241 bar) oil pressure. NEVER start or operate the pump when any of the manifold assembly parts are loose or removed.

Service steps

1. Shut down the system.
 - Note:** When working on the relief valves, drain the oil from the reservoir into a clean container large enough to hold 37 gallons (140 L).
2. Place absorbent pads under the relief valve to catch spilled oil.
3. Use a 30 mm (or 1³/₁₆-in.) socket and handle on the main body of the relief valve to unscrew it from the manifold. It may be necessary to use a universal joint and extension on the socket to gain access under the manifold return oil hose. If this is not available, remove the hose end from the manifold fitting.
4. Install the new relief valve and tighten in place. Re-install the return oil hose end if removed in the previous step.

If the reservoir was drained in Step 1, refill the reservoir.

5. Remove the *Out of Service* tags from the main electrical disconnects.
 - Note:** This service procedure introduces a small amount of air into the hydraulic system which will purge automatically on pump unit start-up.
6. Run the pump unit at low pressure for 3–5 minutes while checking for leaks. Remove tools, parts and rags from the pump unit. The pump unit is ready for operation.

Shift sensor assembly

The shift sensor assembly consists of an actuating pin, actuating plunger assembly, spring, sensor housing and two cap screws. The assembly requires no routine maintenance.

How it works

As the intensifier low-pressure piston nears the end of its stroke, it pushes on the actuating pin. The actuating pin pushes on the actuating plunger and spring, which brings the magnet end into the cupped end of the sensor housing. The magnetic field causes the sensor to send a signal to the integrated shift module, which energizes the appropriate pilot valve solenoid coil. This causes the intensifier to stroke in the opposite direction. See *Integrated shift module* for a description of the module indicator LED sequence of operation.

Service tips

The most common shift sensor problems are:

- Leakage due to a worn o-ring
- A stalled or erratically shifting intensifier caused by a broken spring
- A stalled intensifier caused by a break in the wiring. To check the shift sensor wiring, stand in front of the pump.

The shift sensor electrical connections are as follows:

Connector location	Connects to
Bottom left	Left-hand shift sensor
Bottom right	Right-hand shift sensor

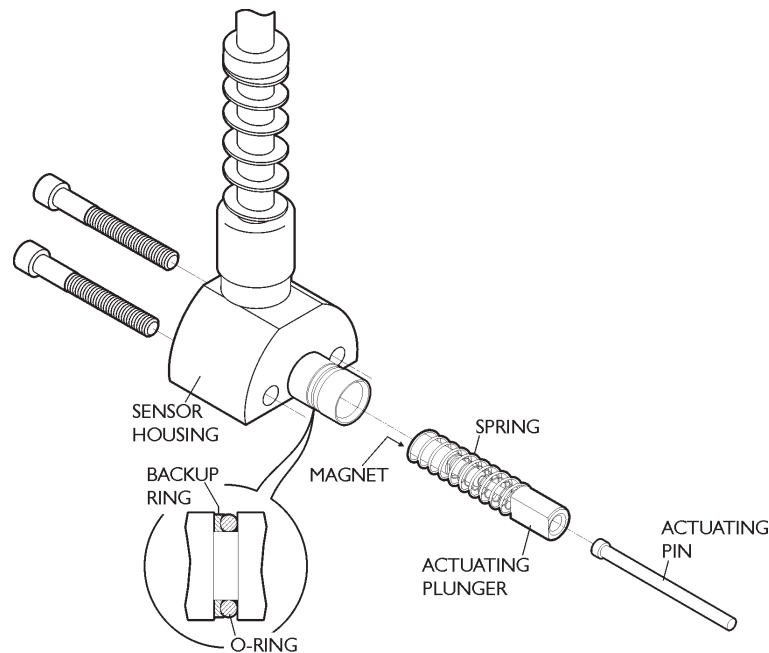

Replacing a shift sensor assembly

Service steps

1. Shut down the system.

WARNING

Place the main electrical disconnects in the OFF position and bleed down all high-pressure lines. Place *Out of Service* tags on the main electrical disconnects and lock them out. Failure to do so can result in equipment damage or injury to personnel.

2. Disconnect the shift sensor assembly cable from the integrated shift module cable extension.
3. Remove the two shift sensor housing cap screws (5/2-in. socket), then remove the housing from the end bell.
4. Remove the spring and actuating plunger. Inspect the spring for wear and for broken coils. The spring should have a free length of approximately 1.5 in. (38 mm).

Inspect the actuator plunger assembly for a chipped magnet, loose retaining screw, or broken spring. The plunger should be 2.23 in. (56.6 mm) long. Replace components if necessary.

5. Remove the actuating pin. You will need the shift pin tool (002228-1) and a 6 in. (150 mm) long piece of insulated electrical wire that fits the shift pin tool groove closely. Strip the insulation at one end for 1/4 in. (6 mm) and fray out the wires.

Lubricate the o-ring of the shift pin tool and insert the tool into the intensifier shift sensor housing bore, o-ring end first. Pulling out the tool creates suction, which pulls the pin into the main bore. Remove it using the frayed end of the wire.

6. Inspect the actuating pin. It should be approximately 1.15 in. (29.2 mm) long, have a shaft diameter of 0.080–0.085 in. (2.03–2.16 mm), and have no measurable bend. Replace if necessary.
7. Inspect the actuator bore in the end bell. It must be polished and have no gouges, burrs, or other surface disruptions.

8. Inspect the sensor housing o-ring and backup ring for wear and damage. Replace as necessary. Lubricate the backup ring and o-ring with Parker Super O Ring Lube (200006). Install the backup ring first and then install the o-ring on the outer, end bell end of the housing.

9. Reinsert the actuating pin into the end bell:
 - a. Place the pin in the groove of the shift pin tool with the pin head toward the o-ring.
 - b. Insert the tool into the shift sensor bore with the o-ring end facing out. When the tool is fully engaged, use the wire to apply pressure against the pin. Rotate the tool in the bore until the pin lines up with the actuating pin bore. The pressure will force the actuating pin into the bore.
 - c. When the pin is correctly installed, hold it in position with the wire and remove the tool.

10. Reinsert the actuating plunger into the bore with the magnet end outermost.
11. Reinstall the spring.
12. Insert the shift sensor housing into the end bell. Reinstall the two housing cap screws and torque to 10 ft-lb (14 N-m).
13. Reconnect the shift sensor cable to the shift module cable extension.
14. Make sure all shift sensors are in place.
15. Remove the *Out of Service* tags from the main electrical disconnects.

Note: This service procedure introduces a small amount of air into the hydraulic system. It will purge automatically on pump unit start-up.

16. Run the pump unit at low pressure for 3–5 minutes while checking for leaks. Remove tools, parts and rags from the pump unit. The pump unit is ready for operation.

CHAPTER 6

Engineering Drawings

The following drawings are provided with this manual. Please note that drawings are provided for reference only. Drawings and part numbers can become obsolete as a part of Flow's ongoing product improvement. If part numbers are replaced by new numbers, Flow Customer Service will inform you when you order new parts. The drawings listed below are either illustrated in this chapter, or provided on the CD-ROM.

HyperJet 94i-S

042570	HyperJet 94i-S assembly
020505	Booster pump assembly
020552	Water filter assembly
020851	Hydraulic schematic
041158	Reservoir assembly
042014	Cover package
A-22018-1	Heat exchanger

HyperJet 94i-D

042210	HyperJet 94i-D assembly
020704-1	Water filter assembly
020850	Hydraulic schematic
040588-1	Booster pump assembly
041570-1	Heat exchanger
042013	Cover package
042451	Reservoir assembly

Subassemblies used on both models

019579	Attenuator assembly
020070	Intensifier/manifold assembly
020071	Check valve assembly
020101-X	PLC enclosure assembly
019309	Bleed-down assembly
020544-X	CE gauge panel assembly
020670	Motor/pump assembly
041423	Remote enclosure assembly
042809	Plumbing package

Kits

040505-1	HyperJet 94i-D label kit
040521-1	HyperJet 94i-S label kit
020708	Hose kit

Spares

A-12819 Oil filter

Consumables kits

040467-X Rev. B

Item	Part #	HyperJet 94i-S	HyperJet 94i-D	Description
		-1	-2	
1	040015-1	4	8	Seal cartridge
2	014884-1	2	2	Check valve inlet repair kit
3	014885-1	4	4	Check valve outlet repair kit
4	013157-1	1	1	Low-pressure seal kit
5	A-2185	1	1	Blue Lubricant
6	015084-1	1	1	Bleed-down valve repair kit
7	A-1449	1	1	0.45 micron filter cartridge
8	A-1555	1	1	1 micron filter cartridge

040207-1 Rev. A
Hose kit for HyperJet 94i-S Pump

#	Qty	Part #	Description
1	1	A-0410-17	Hose assembly, 1/4" ID x 17"
2	1	A-00230-40	Hose assembly, 40"
3	1	A-0410-29	Hose assembly, 1/4" ID x 29"
4	1	A-0410-55.5	Hose assembly, 1/4" ID x 55.5"
5	1	A-0424-22.5	Hose assembly, 1/4" ID x 22.5"
6	1	A-00230-30.5	Hose assembly, 30.5"
7	1	A-00930-39	Hose assembly, 3/4" ID x 39"
8	1	A-00930-55.5	Hose assembly, 3/4" ID X 55.5"
9	40"	A-0805-5	Hose, 2" ID
10	1	A-22038-25.5	Hose assembly, 25.5"
11	1	A-22065-54	Suction hose assembly, 1" ID
12	1	A-22163-32.5	Hose assembly, 32.5"
13	1	A-0434-39.5	Hose assembly, 1" ID x 39.5"

For the intensifier

Refer to manual M-376, 94K HyperJet™ Intensifier

Kits

- 014884-1 Check valve inlet repair kit
- 014885-1 Check valve outlet repair kit
- 013157-1 Low-pressure seal kit

Other parts

- 040015-1 Seal cartridge

020708-1 Rev. E
Hose kit for HyperJet 94i-D Pump

#	Qty	Part #	Description
1	1	A-00230-35.75	Hose assembly, 35.75"
2	1	A-00840-17.75	Hose assembly, 3/8" ID
3	1	A-00930-28	Hose assembly, 3/4" ID x 28"
4	1	A-0410-19.5	Hose assembly, 1/4" ID
5	1	A-0410-29.75	Hose assembly, 1/4" ID
6	1	A-0410-43.5	Hose assembly, 1/4" ID
7	1	A-22164-39	Hose assembly, 39"
9	1	A-0434-19.625	Hose assembly, 1" ID
10	1	A-04340-27	Hose assembly, 1" ID x 27"
11	1	A-0434-40	Hose assembly, 1" ID x 40"
12	1	A-0434041	Hose assembly, 1" ID x 41"
13	1	A-04340-59.75	Hose assembly, 1" ID x 59.75"
15	1	A-0805-5-40.25	Hose assembly, 2" ID x 40.25"
16	1	A-22038-24.5	Hose assembly, 24.5"
17	1	A-22038-25.25	Hose assembly, 25.25"
19	1	A-22163-33.25	Hose assembly, 37"
20	1	A-22065-43.75	Suction hose assembly, 1"
22	1	A-220650-51.25	Suction hose assembly, 1"
23	1	A-0424-43	Hose assembly, 1/4" ID x 43"
24	1	A-0805-5-39.5	Hose assembly, 2" ID x 39.5"

Service kits

015084-1 Bleed-down valve repair kit

Item	Part #	Qty	Description
1	011746-1	1	Poppet
2	011747-1	1	Seal
3	011748-1	1	Bearing
4	011749-1	1	Back-up ring
5	013051-1	1	Valve seat
6	A-0275-112	1	O-ring
7	A-0275-212	1	O-ring
8	A-0275-119	1	O-ring
9	A-0275-120	1	O-ring
10	A-0276-212	1	Back-up ring
11	A-0290-010	1	High-pressure o-ring

B-1813-1 Check valve lapping kit

Item	Part #	Qty	Description
1	A-1904	1	Glass plate
2	A-1903	3	320 grit grinding paper
3	A-1902	3	600 grit grinding paper

HyperJet 94i-S tubing kit

Item	Part #	Description
1	013345-4.3	$\frac{3}{8}$ straight tubing
5, 17	013345-7.75	$\frac{3}{8}$ straight tubing
12	019421-6	3.5 x 3.5 elbow tube
14	019421-13	7.8 x 11.2 elbow tube
18	042209-1	Bleed-down tubing
19	041336-1	50 hp tube
20	A-0782-6	Tubing nipple
21	042921-1	Bleed-down coil

HyperJet 94i-D tubing kit

Item	Part #	Description
1,3,4,5	013345-7.4	$\frac{3}{8}$ straight tubing
7,10	013345-7.75	$\frac{3}{8}$ straight tubing
15	042921-1	Bleed-down coil
16	019421-6	3.5 x 3.5 elbow tube
19,24	019421-10	7.73 x 15 elbow tube
22	042209-1	Bleed-down tubing
23	019421-12	7.8 x 48 elbow tube
25	A-0782-6	Tubing nipple

Tools

040226-2

Tool kit

Item	Part #	Qty	Description
1	014630-1	1	Plunger seal tool
2	014631-1	1	Seal guide tool
4	A-10039	1	Anti-seize lubricant
5	A-1275	1	Strap wrench
6	A-2185	1	Blue lubricant
7	A-3202	1	Loctite #242
8	A-4689	2	Food grade grease
9	A-8466	4	Medical alert card
10	B-1813-3	1	Check valve lapping kit
11	002228-2	1	Shift pin tool assembly
12	014030-1	1	End bell assembly tool
13	A-00296-28	2	Hex screw
14	A-22043-1	1	Torque multiplier
15	A-23704-1	1	Drive socket
16	A-22223-1	1	Wrench
17	A-22224-1	1	Thread restoring file
18	A-21544-1	1	Hydraulic hand pump
19	A-21535-2	1	15,000 psi gauge
20	019375-1	1	Torque tool cap
21	014713-1	1	Torque tool piston
22	007100-1	4	Attenuator washer
23	040358-1	4	Hex nut
24	A-0275-157	1	Buna o-ring
25	A-0276-157	1	Nitrile backup ring
26	A-19813-1	1	Crows foot wrench
27	SB-0195	1	Assembly & breakdown bulletin
28	019624-1	1	Adapter
29	A-20283-31	1	Shipping crate

Label kits

040521-1 Rev F

Label kit for HyperJet 94i-S

#	Qty	Part #	Description
1	1	001843-1	CE Caution label
2	1	011980-22	Hot spot label
3	1	040515-1	Oil service label
4	1	B-6278-2	1-micron filter label
5	1	B-6278-3	5 micron filter label
6	2	C-1060-15	Warning label
7	1	C-5683-1	Attention Danger label
8	2	C-5683-4	Attention Danger label
9	1	010769-1	Model/serial number label
10	1	042697-1	Intensifier pump label
11	4	010814-1	CE ground label
12	1	C-1060-11	Bleed-down water label
13	1	C-1060-2	Water leakage label
14	1	C-1060-3	Water in label
15	1	C-1060-4	Water drain label
16	1	C-1060-9	Filtered water in label

040505-1 Rev D

Label kit for HyperJet 94i-D

#	Qty	Part #	Description
1	1	001843-1	CE Caution label
2	1	010769-1	Model/serial number label
3	4	010814-1	CE ground label
4	1	011980-22	Hot spot label
5	1	040515-1	Oil service label
6	1	B-6278-2	1-micron filter label
7	1	B-6278-3	5 micron filter label
8	2	C-1060-15	Warning label
9	1	C-5683-1	Attention Danger label
10	1	C-5683-4	Attention Danger label
11	1	042697-1	Intensifier pump label
12	1	C-1060-11	Bleed-down water label
13	1	C-1060-2	Water leakage label
14	1	C-1060-3	Water-in label
15	1	C-1060-4	Water drain label
16	1	C-1060-9	Filtered water in label

Miscellaneous service parts

A-2185 Blue Lubricant

Anti-galling compound for all threaded high-pressure connections.

A-4689 White Food Grade O Ring Lube

Use as a lubricant for all o-rings that come in contact with water.

200006 Parker Super O Ring Lube

Use as a lubricant for all o-rings that come in contact with hydraulic oil.

**MS-2258 Intensifier Pump Maintenance
and Service Log**

One copy is provided on the CD-ROM.

CHAPTER 7

Customer Support

MS-2266, Customer Support

Notes