



SHAPE TECHNOLOGIES GROUP®

---

# MACH 200 SYSTEM MANUAL

Includes Ancillary Options

M-813 | Rev. C | en | December 2020

---



SHAPE TECHNOLOGIES GROUP®

## About this content

---

Due to continuing product improvement, the information contained in this document is subject to change without notice. Flow International Corporation shall not be held liable for technical or editorial omissions made herein, nor for any incidental or consequential damage resulting from the use of this material.

### Registered trademarks

In the United States, Dynamic Waterjet®, FlowCUT®, FlowMaster®, FlowNEST®, FlowPATH®, FlowXpert®, HyperJet®, HyPlex®, Paser®, and XD® are registered trademarks of Flow International Corporation.

Windows is either a registered trademark or trademark of Microsoft Corporation in the United States and/or other countries.

All other registered trademarks shown are the property of their registered owners.

### Copyright

This content contains information protected by copyright. No part of this document shall be reproduced in any manner without prior written consent from Flow International Corporation.

© 2020 Flow International Corporation. All rights reserved. ORIGINAL INSTRUCTIONS.

### Other notes

- If you see a reference to the number of "pages" included in a section, it is referring to the number of articles in that section. It is not a physical page count. Similarly, footnotes are at the end of an article, not always at the end of a physical page.
- Images shown are for general reference only and may vary from actual product.

### Symbols used in content



Discard part



Keep this part; you will install it later in the procedure.



SHAPE TECHNOLOGIES GROUP®

## Service and Support

---

We've committed ourselves to the success of our customers for over 40 years. As a result, nearly 1 out of every 3 systems built is delivered to repeat customers. We are proud to provide the largest and most highly trained support team, with the experience to ensure your success.

### **United States & Canada**

23500 64th Avenue South · Kent, Washington 98032 · USA  
Tel: 1.800.526.4810

### **Central America, South America, Mexico & Caribbean**

Tel: +54 9 11 4700 8881 or 8882

### **Europe, Middle East & Africa**

Gutenbergstrasse 10 · D64331 Weiterstadt · Germany  
Tel: +49 (0) 6151 3095-0

### **Taiwan, China, Korea, Southeast Asia, Australia & New Zealand**

Tel: +86-21-5438-2222

### **Japan**

Tel: +81-52-701-7021



SHAPE TECHNOLOGIES GROUP®

## Safety

---



**Important! Read carefully before use. Keep for future reference.**

### Safety

Pages: 13

- **How we show safety messages in content**  
How we show safety messages in content.
- **Intended use statement**  
Review of what the intended use is, who the intended user is for systems—including ancillary options—and modifications.
- **Emergency medical information**  
Vital information to be given to medical personnel in case of emergency.
- **Lockout/Tagout (LOTO)**  
Supplemental instructions to your facility Lockout/Tagout procedures. Includes instructions for systems and CF900 hopper.
- **Personal Protective Equipment (PPE)**  
Recommendations for PPE.
- **Electrical safety**  
Includes instructions for the electrician.
- **Exceptional or emergency situations**  
What to do if you come across these exceptional or emergency situations.
- **Safety during cleaning**  
Safety precautions to follow during cleaning.
- **Safety during maintenance**  
Follow these safety precautions while doing maintenance.

- **Safety during operation**  
Safety precautions to follow during operation.
- **Safety for transport**  
Recommendations to follow if you have to transport the machine.
- **Transporting the CF900 hopper**  
Recommendations for how-to transport the hopper.
- **Safety labels**  
Includes information on safety labels and diagrams.



SHAPE TECHNOLOGIES GROUP®

## How we show safety messages in content

---

In our content, safety messages are highlighted with the safety alert symbol and a signal word, only a signal word, or only a signal word panel. Pay attention to these safety messages—they alert you to hazardous situations!

### Safety alert symbol

---



This is the safety alert symbol. It is used to alert you to potential physical injury hazards. Obey all safety messages that follow this symbol to avoid possible injury or death.

### Signal words

---

#### **WARNING!**

WARNING indicates a hazardous situation, which if not avoided, could result in death or serious injury.

#### **CAUTION!**

CAUTION indicates a hazardous situation, which if not avoided, could result in minor or moderate injury.

### Signal word panels

---



DANGER indicates a hazardous situation, which if not avoided, will result in death or serious injury.



NOTICE indicates a non-hazardous situation, which if not avoided, could result in property damage.



SHAPE TECHNOLOGIES GROUP®

## Intended use statement

---

### Intended use

---

The machine is used to cut virtually any type of material, including metal, stone, glass, and composites, across various industrial sectors.

Additional applications may be possible, but only with appropriate adjustments to the machine, which must be discussed with the manufacturer. A new Conformity Evaluation may be required and additional guidelines may then apply.

Any other use of the machine is not in accordance with its intended use and therefore not permissible.

In particular, the machine is not meant for the processing of explosive materials or materials that release explosive emissions. The machine may not be operated in areas that are vulnerable to explosions. In addition, the machine is not designed for food processing.

During normal operation of the machine, the operator shall maintain a minimum safe distance of 1200 mm (48 in.) from each side of the machine.

### Intended use for ancillary items

- The PASER CF900 Abrasive Delivery System (ADS) is designed for the continuous transport of abrasive to the abrasive metering system located above the cutting head.
- Spreader bars allow a simple means of cutting small repetitive parts quickly, by duplicating the same cutting action simultaneously across multiple cutting heads.

## Intended user

---

System operation and maintenance should be done by Flow-trained personnel. However, other suitably trained personnel may also operate the system and do maintenance on it.

We recommend that all service work be done by Flow Service. However, other suitably trained personnel may do service work on the system.

Work on the electrical or control system may only be done by trained, certified electricians.

## Modifications

---

Modifications to the system, including all machine, pump, cutting head, software, and ancillary components, is prohibited after the manufacturer distributes the system. If the system is altered after distribution, conformity of the machine to the EC directives and standards no longer applies and the CE mark must be removed.

We recommend the exclusive use of original replacement parts.





SHAPE TECHNOLOGIES GROUP®

## Emergency medical information



**WARNING!** Obtain medical treatment immediately for ANY high-pressure waterjet injuries. Even minor injuries that are painless or inconspicuous can lead to grave health problems.

It is vital that medical personnel have information about this type of injury. We recommend that anyone who works with high-pressure waterjet equipment carry a waterproof medical alert card. This card should describe their work and the nature of injuries inherent in using waterjets. You should also inform medical personnel what type of abrasive you used and the type of material you cut.

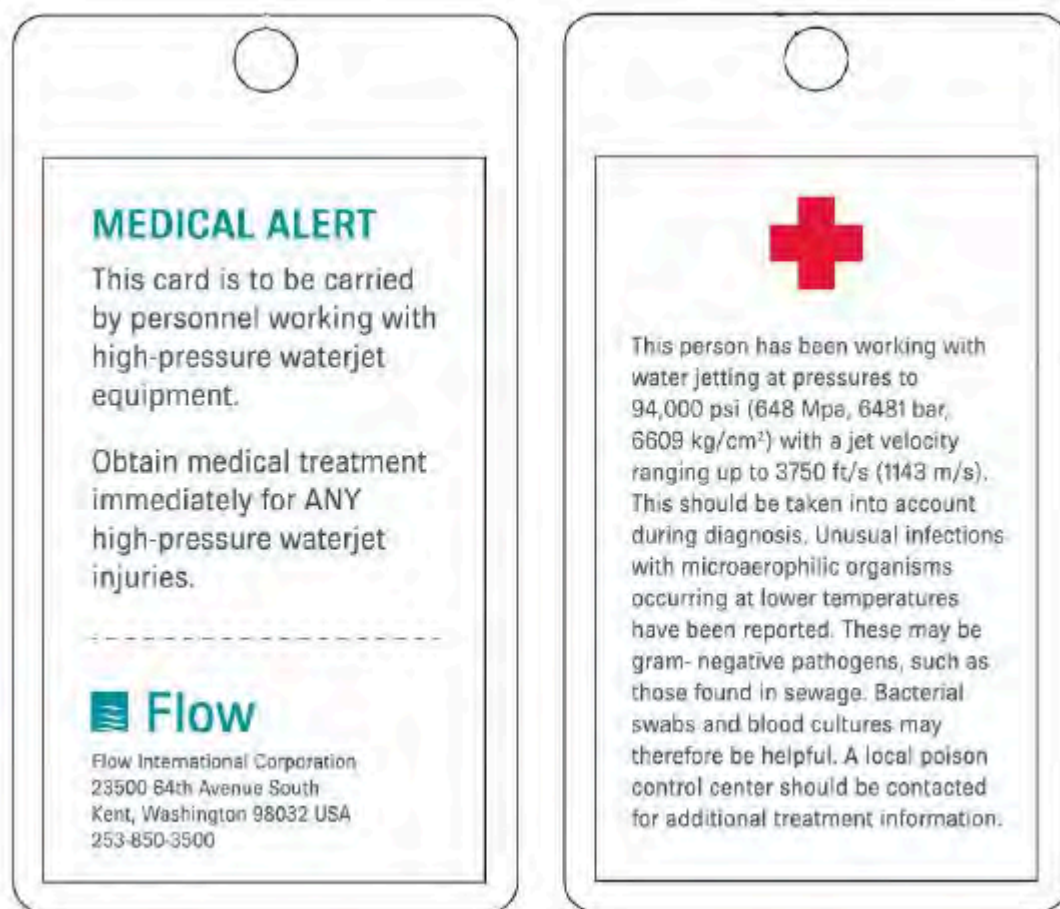

**Medical Alert card part numbers (by language)**

Czech ..... A-8466CZ  
English ..... A-8466  
French ..... A-8466F  
German ..... A-8466G  
Italian ..... A-8466I  
Polish ..... A-8466PL  
Portuguese ..... A-8466P  
Russian ..... A-8466RU  
Spanish ..... A-8466S



SHAPE TECHNOLOGIES GROUP®

## Lockout/Tagout (LOTO)

Only trained personnel can do Lockout/Tagout. These instructions are supplemental to your facility Lockout/Tagout procedures. We recommend your safety personnel approve all Lockout/Tagout instructions for anyone who works around high-pressure waterjet equipment.

To do a Lockout/Tagout, do the following:

1. Jog the cutting head to a loading or safe position.
2. Close all programs, and then press the E-stop.
3. Select **Start > Shut down** to turn off the machine PC.
4. Wait until the machine PC is completely shut down, and then turn off the main power to the machine (pump and machine disconnect).
5. Lock the interface enclosure, and then put an appropriate tag on the enclosure.  
(Picture shown for general reference only and may vary from your machine model.)

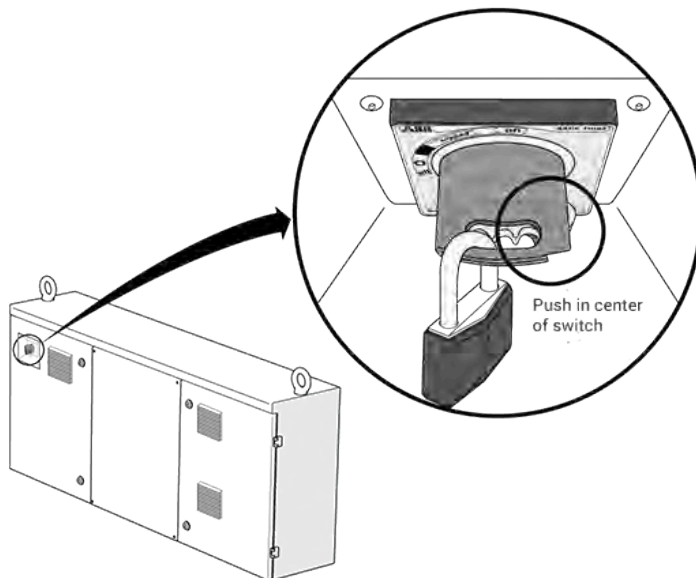

6. Turn off the air and water supply.

## Lockout/Tagout for the CF900 hopper

---

To do a Lockout/Tagout for the hopper, do the following:

- Turn off the power switch, lock it, and then put an appropriate tag on it. Turn off the air supply to the hopper.

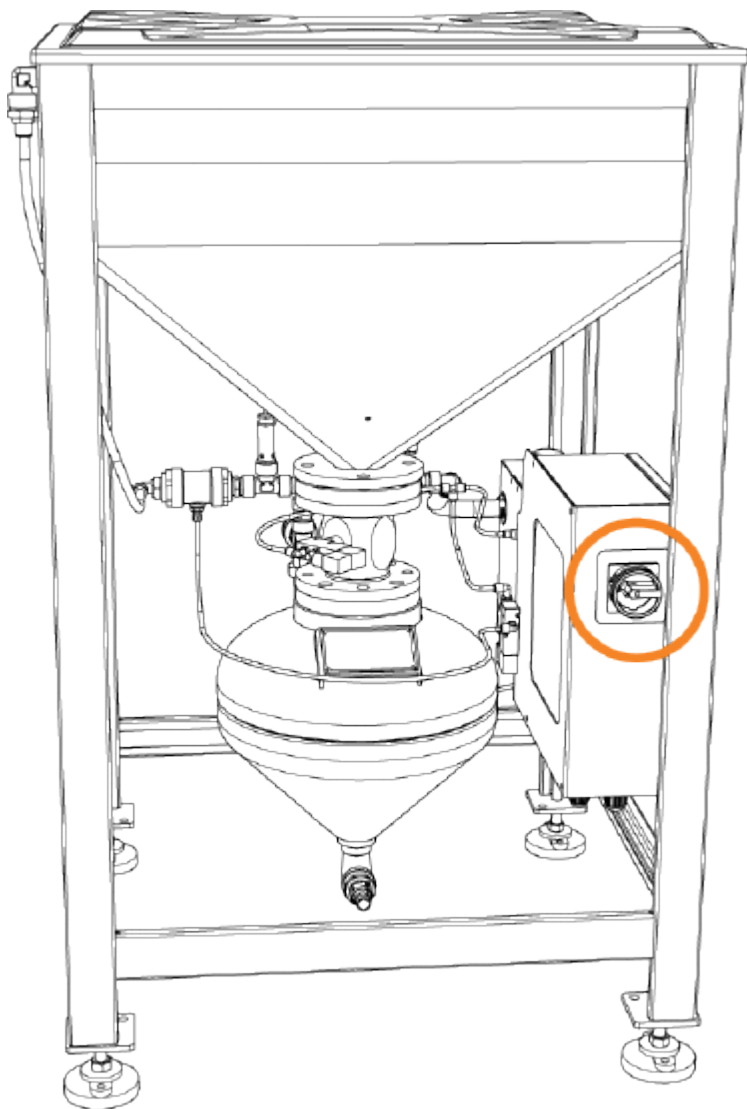





SHAPE TECHNOLOGIES GROUP®

## Personal Protective Equipment (PPE)

Personal protective equipment (PPE) is equipment worn to minimize exposure to serious workplace injuries and illnesses. All PPE clothing and equipment should be of safe design and construction, and should be maintained in a clean and reliable fashion.

We recommend your safety personnel approve all PPE for anyone who works around high-pressure waterjet equipment.

	<p><b>Wear a mask!</b> Wear a dust mask to reduce particle or dust inhalation when you fill the abrasive delivery system with abrasive.</p>
	<p><b>Wear eye protection!</b> Wear safety glasses with side shields or safety goggles to shield your eyes from flying debris and spray, including pressurized abrasive that may leak from the hopper silo or hose.</p>
	<p><b>Wear ear protection!</b> Wear ear protection while the machine is in operation.</p>
	<p><b>Wear protective clothing!</b> Wear protective clothing to shield your body from flying debris and spray.</p>

	<p><b>Wear protective gloves!</b> Wear protective gloves when you handle sharp catcher tank slats or have to work around dirty water in the catcher tank. When you clean a hopper (ADS), wear gloves to prevent abrasive particles from penetrating any skin abrasions.</p>
	<p><b>Wear protective footwear!</b> Wear steel or composite toe footwear.</p>



SHAPE TECHNOLOGIES GROUP®

## Electrical safety

---



Life threatening danger due to surge! Always assume that electrical components are live. Always turn the main switch to the system off when working on the electrical system. Post a sign “Maintenance in Progress—Do Not Energize.” Work on the electrical or control system may only be done by trained, certified electricians. Work must be done in accordance with respective guidelines.

### Instructions for the electrician

---

- If it necessary to work on live components, then a second person must be available to turn the unit current off at the main switch in case of emergency.
- The main switch must always be turned off during maintenance work and service work on the machine. It must be secured against unintentional activation with a lock for the length of the work.
- To protect sensitive components in the machine control, the electrician must ground themselves before working at the control computer and the PLC control.
- Only specified safety mechanisms of equal power and inertia should be used.
- Only measuring tools in accordance with respective guidelines should be used.
- Always take great care when the electrical system is being worked on.
- Only use insulated tools when working on the electrical system.
- All replacement wires or cables must conform to the manufacturer’s specifications, including color coding, wire numbers, and size.



SHAPE TECHNOLOGIES GROUP®

## Exceptional or emergency situations

---

### Contact with special materials

---

Note the safety datasheets of the manufacturer when you handle colors, solvents or special substances. Such substances must be stored in accordance with applicable ordinances (Operational Facility Ordinance). Note the local wastewater regulations.

### Electrostatic discharges

---

During cutting, the high flow rate of water and abrasive could cause electrostatic charging. Discharges could lead to the ignition of flammable substances, dust, or gases. Ground all components so that static electricity does not form a spark.

The machine comes with the appropriate grounding cables. If the cables are defective, replace them immediately.

### Emissions

---

Always pay attention to the data sheets of the material being cut! Although rare, flammable gases could develop in the water if you cut materials (such as aluminum) that lead to aggressive oxide formation. Work in a well-ventilated area to minimize exposure to vapors that could occur.

To avoid deflagrations, lower the water level in the catcher tank until the water is under the bottom of the material.

### Explosions

---

Do not operate the machine in areas that are vulnerable to explosions.

If you weld, do flame cutting, or use an angle grinder in close proximity to the machine, clean the surrounding area and remove flammable materials. Under certain conditions, material dust can lead to deflagration or explosion.



## Fire

---

If you cut flammable or difficult-to-extinguish materials, pay particular attention to fire prevention/ extinguish protocols.

Familiarize yourself with the exit routes at your facility. Know how to trigger a fire alarm. Know where fire extinguishers/blankets are located and how to use them. Know what the appropriate extinguisher is to use for the materials you process.

In the event of a fire, keep calm. Call the fire department, and follow evacuation protocols.



SHAPE TECHNOLOGIES GROUP®

## Safety during cleaning

---

Follow these safety precautions during cleaning:

- Do not clean any part of your machine with the high-pressure water stream.
- Only use recommended cleaners (or equivalents) to clean your machine. Follow the safety instructions given by the manufacturer of the cleaner.
- Only use cleaners in well-ventilated areas. Avoid prolonged breathing of fumes and contact with skin or eyes.

## Keep a clean work environment

---

- Keep the area around the machine clean and free of obstacles.
- Keep the floor clean and dry—abrasive residue, material dust, and water make the floor slippery. We recommend that you use grid plates or anti-slip mats to reduce the risk of slipping.
- Do not use any part of the machine as a place to store things.



SHAPE TECHNOLOGIES GROUP®

## Safety during maintenance

---

### General

---

- Do a Lockout/Tagout on the system—including the machine, high-pressure pump, and all ancillary equipment—before you do any maintenance. (Electrical and pneumatic air).
- Be alert at all times when doing maintenance on the machine.
- Do not patch damaged hoses—replace them.
- High-pressure water can remain in the system for an extended time after shutting down the water source. Always bleed-down system pressure before servicing any part of the system.
- Do not exceed specified pressure setting limits for pneumatic or hydraulic components. Exceeding these limits may result in serious injury to personnel or damage to the equipment.
- Torque all fittings to the manufacturer's torque specifications.
- Follow the manufacturer's recommendations for maintaining the equipment, and use only original manufacturer replacement parts.
- Follow the manufacturer's system startup procedure to ensure safe operation.
- Use care when lifting equipment covers during operation.

### High-pressure system safety

---

- Do not patch high-pressure tubing—replace it.
- Welding on high-pressure component or high-pressure tubing is forbidden.
- Do not step on or lean against high-pressure tubing. Doing so could cause leaks.
- Do not touch weep holes with your bare hands or try to stop water by plugging the holes.
- Only use high-pressure fittings, valves, and tubing that are rated for the pressure of your equipment [4150 bar (60,000 psi) or 6000 bar (87,000 psi)], depending on your configuration].
- Do not exceed specified operating pressures for high-pressure water system components.

## Tools

---

- Special tools could be provided for certain work. Only use these special tools for the work intended. Follow the procedures for using the tool(s) to avoid injury or damaged components.
- If instructions call for the use of a certain tool, only use the tool specified to avoid injury or damage components.



SHAPE TECHNOLOGIES GROUP®

## Safety during operation

---

### General

---

- The waterjet stream can sever or severely injure human extremities. Do not allow the waterjet stream to touch any part of your body. Do not point the waterjet stream at anyone. Do not put anything in its path that you do not intend to cut.
- Don't start the system unless you know how to stop it.
- Do not leave the machine unattended. Be alert at all times while the machine is in operation. If there are people in the vicinity of the waterjet system, make sure they are clear of the hazard area before the waterjet is activated or the part program is run. Clear communication helps prevent unexpected movement/activation of the waterjet.
- Do not touch high-pressure components when they are pressurized.
- Never try to support the workpiece by holding it with your fingers, either above or below the workpiece—the jet retains almost all of its cutting power below the work.
- Never put your hands in the tank when the machine is operating. Plan material clamping—in advance—so that you don't handle material or parts while the machine is in operation.
- Never climb on or around the equipment on makeshift devices. Use only approved catwalks, ladders, or platforms.
- Never walk directly on the catcher tank slats to remove parts. Slat can weaken over time fail.
- Always use the appropriate lifting equipment to move material on and off the work platform.

### For the CF900 hopper

- Never operate the ADS unless the abrasive outlet hose is connected to the waterjet machine.
- Always keep the lid on, except when adding abrasive. The lid prevents abrasive from spraying from the silo when the vessel releases pressure before entering the fill cycle.

### For machines with a spreader bar

- Using the spreader bar increases the likelihood of a pinch point hazard with the side of the catcher tank.
- Make sure that the ultra-high pressure water is off and that a part program is not running before you toggle the on/off switch on the spreader bar.

- It is possible to cut over the water level adjustment bladder if the cutting heads are positioned as such. Severe damage to the machine will occur if the bladder is cut by the high-energy waterjet. Before you run a part program, make sure the cutting head will not cut through the bladder.

**Abrasive**

---

Garnet is the most frequently used abrasive. It is generally considered inert and has no known health hazards. NEVER use silica sand as an abrasive—the dust produced causes silicosis, a lung disease.

Never disconnect abrasive feed lines while under pressure. This can cause abrasive to spray into eyes.

**Noise emission**

---

During the normal cutting operation—with the bottom of the material to be cut under water—the distance of the nozzle exit to the material smaller than 2.5 mm – the noise emission is under 85 dB(A).

However, under certain circumstances, the machine causes higher noise emissions. At the start of material drilling or cutting above the water, the noise level can climb over 115 dB(A). Always wear hearing protection. The longer the jet, the higher the noise level.

Under certain circumstances, the area surrounding the machine can amplify sound effects, which must be noted.

If the surrounding area becomes noisy, the sound from the adjacent areas must be monitored and the necessary measures taken.

**For the CF900 hopper**

Sound levels were measured 1 m (3 ft) from the front of the ADS and 1.6 m (5 ft) from the ground, during the following actions:

Conveying abrasive.....	69.6 dBa
Pressurization.....	79.4 dBa
De-pressurization.....	98 dBa



SHAPE TECHNOLOGIES GROUP®

## Safety for transport

---

We recommend the following:

- Always disconnect the power supply and empty the catcher tank—even if the machine is only moved a short distance.
- Load and unload all equipment with a properly rated forklift in accordance with local regulations. Make sure that you have flaggers and spotters present while you load or unload equipment. Never walk under a hanging load.
- Secure the load so that it does not move during transport.

## Disposal or recycling

---

Dispose of or recycle the machine and its components in accordance with all local regulations.



SHAPE TECHNOLOGIES GROUP®

## Transporting the CF900 hopper

---

### To transport the hopper

---

Before you transport the hopper, make sure you do the following:

1. If you plan to connect the hopper to a different voltage power supply in the new location, please contact Flow Service.
2. Remove abrasive from the silo.



**WARNING!** If you leave abrasive in the silo, it could cause an unsafe high center of gravity during transport.

3. Lift the hopper with a forklift or pallet jack. Place the forks under a pair of lower beams on the frame (accessible from all four sides).



**WARNING!** Load and unload all equipment with a properly rated forklift or pallet jack in accordance with local regulations. We recommend that you have flaggers and spotters present while you load or unload equipment.

4. Secure the load so that it does not move during transport.

### To set up the hopper after transport

---

To set up the hopper after transport, do the following:

- Put the equipment in position, and then level the hopper using the level pads. If required, use anchor bolts to attach it to the floor.





SHAPE TECHNOLOGIES GROUP®

## Safety labels

Safety labels alert you to a hazard. Do not remove the labels from your system. If a label becomes illegible or damaged, replace it immediately. Cross reference the labels shown on the equipment and/or in the diagrams to the applicable label section.

- Mandatory Action labels convey actions you must take to avoid hazards that could result in personal injury.
- Prohibited Action labels convey actions that are prohibited because it could result in personal injury.
- Hazard Alert labels warn you of hazards which could result in personal injury.

### Mandatory Action labels

 <p>Read the manual before operation. Save all instructions for use.</p>	 <p>Wear protective clothing.</p>
 <p>Wear a dust mask.</p>	 <p>Wear protective gloves.</p>
 <p>Wear eye protection.</p>	 <p>Wear safety footwear.</p>
 <p>Wear ear protection.</p>	 <p>Lockout/Tagout</p>

### Prohibited Action labels

 <p>Do not step in this area.</p>	 <p>Do not enter. Authorized personnel only.</p>
--	---

### Hazard Alert labels

 <p>General warning</p>	 <p>Risk that you could crush your hand(s) due to moving parts.</p>
 <p>Risk of electrical shock</p>	 <p>Pinch point hazard</p>
 <p>Protective Earth Ground</p>	 <p>Risk that you could crush your body due to force from the side.</p>
 <p>Risk that you could slip or fall due to wet or slick surfaces.</p>	 <p>Risk that you could entangle your hand(s) in machinery due to belt drive.</p>
 <p>Risk that you could sever your fingers due to pressurized water.</p>	 <p>Risk of flying debris. Wear eye protection.</p>



SHAPE TECHNOLOGIES GROUP®

# Machine safety labels · Mach 200

View 1

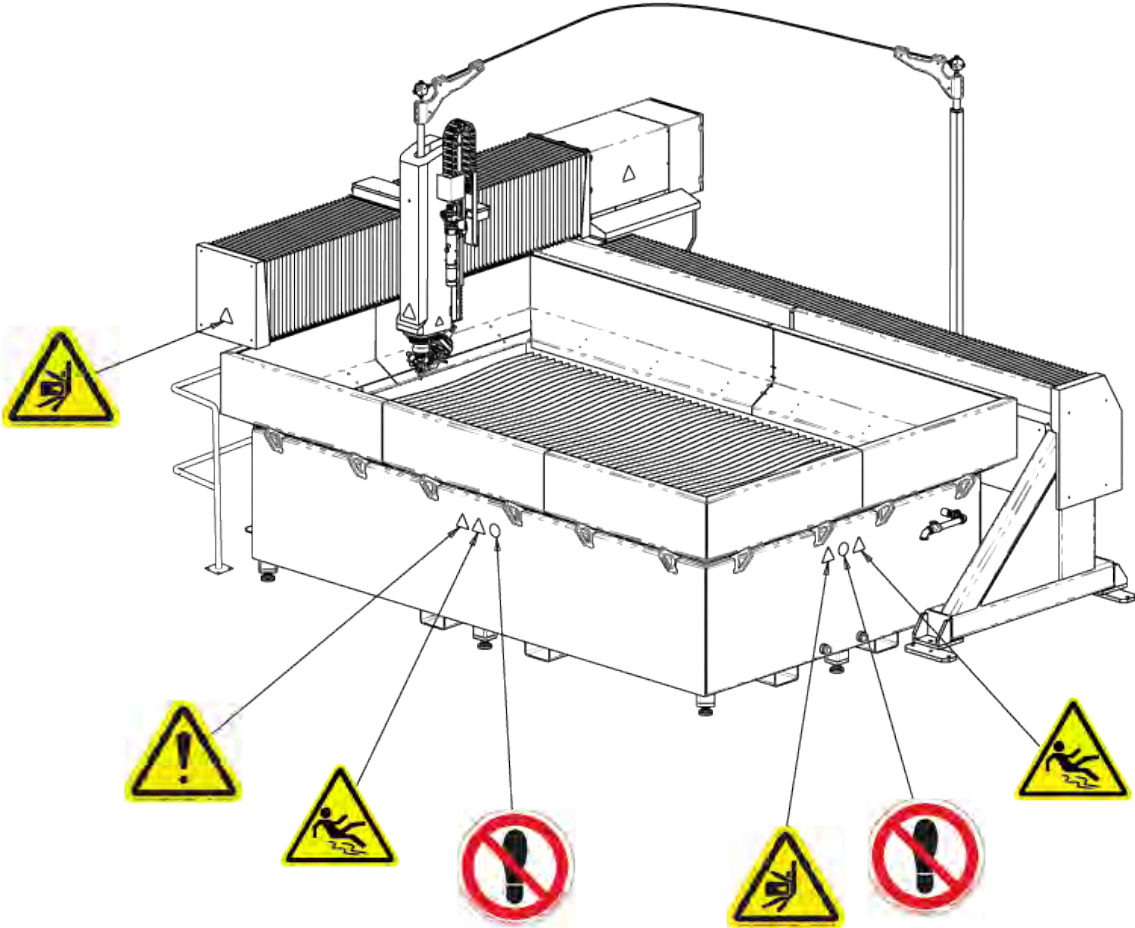

View 2

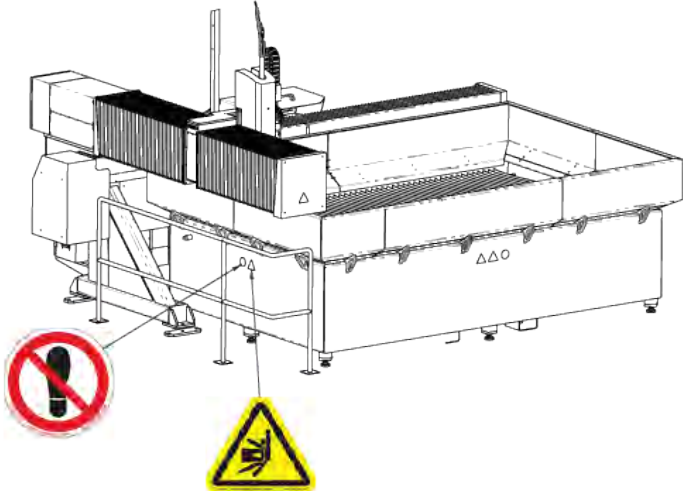

View 3

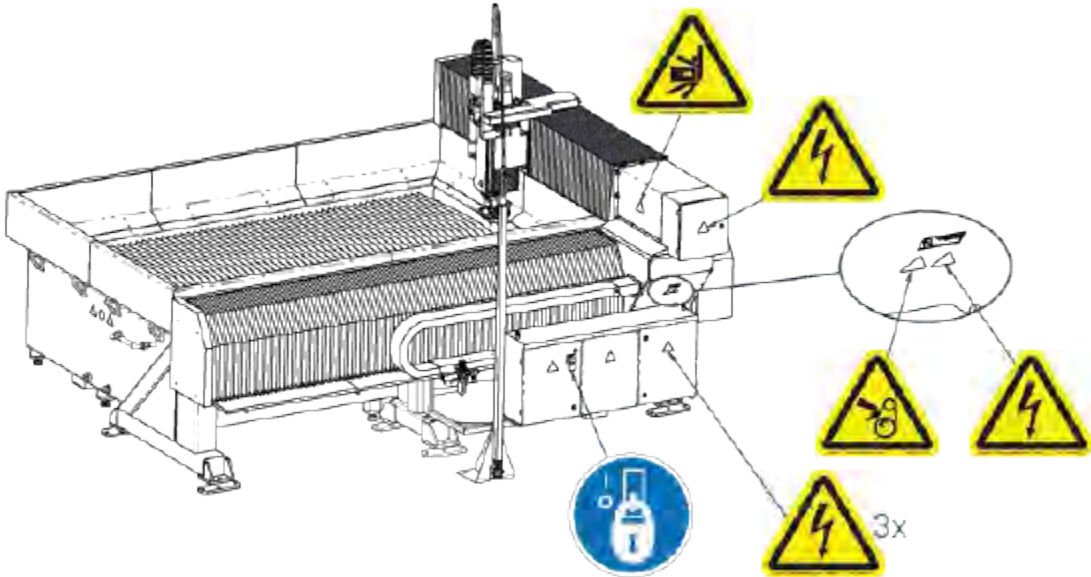

View 4 · Z-axis cover

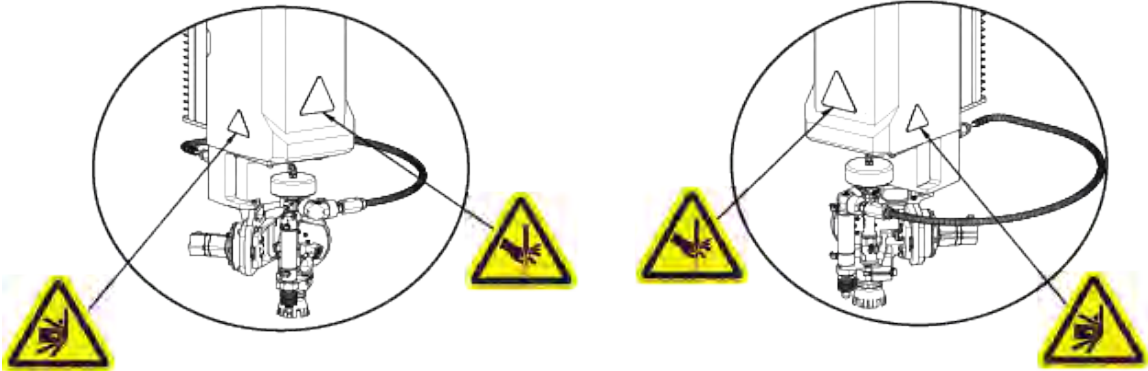

View 5 · Roll-around console

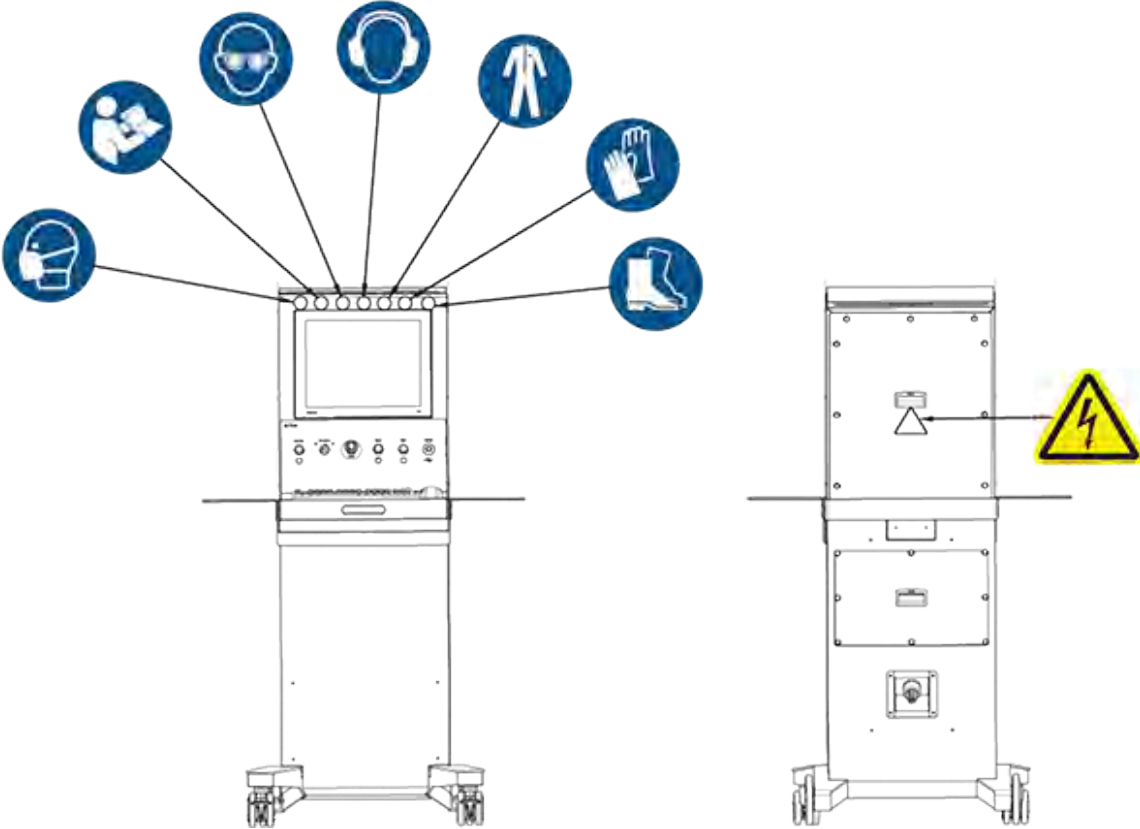



SHAPE TECHNOLOGIES GROUP®

# CF900 hopper safety labels

**Where used**

(Ancillary option) Mach 500 · Mach 300 · Mach 200 · Mach 100

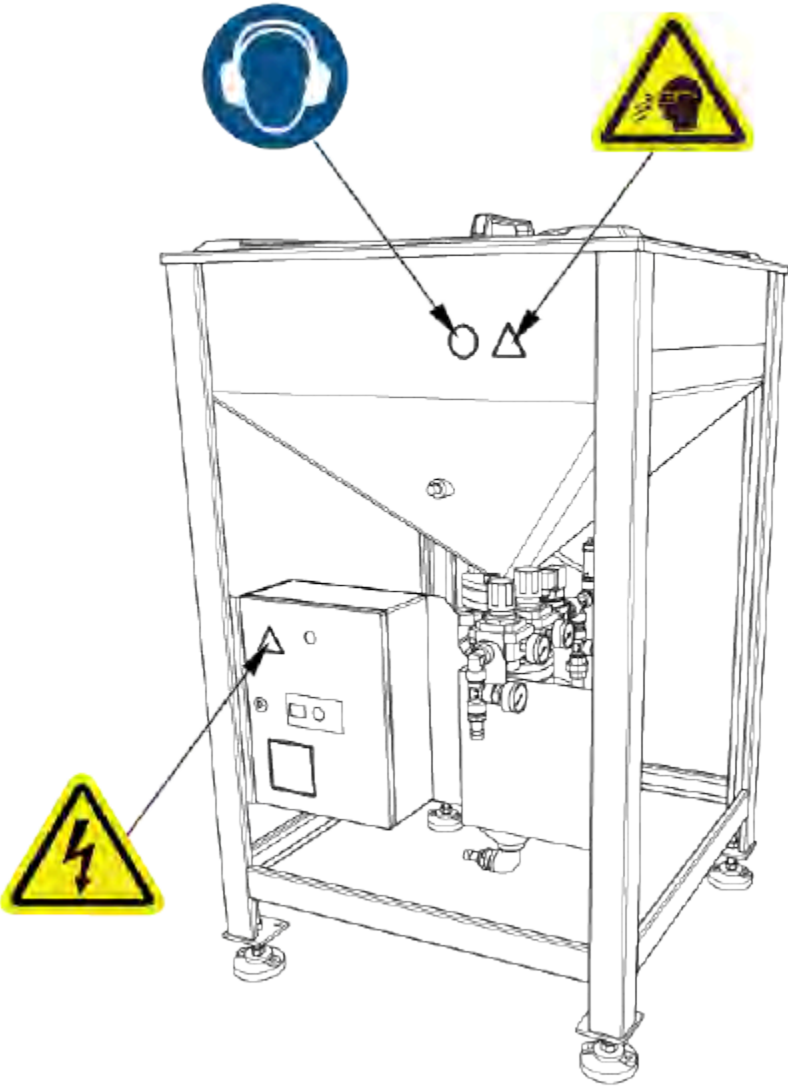



SHAPE TECHNOLOGIES GROUP®

# Light curtain safety labels

## Where used

(Ancillary option) Mach 500 · Mach 300 · Mach 200

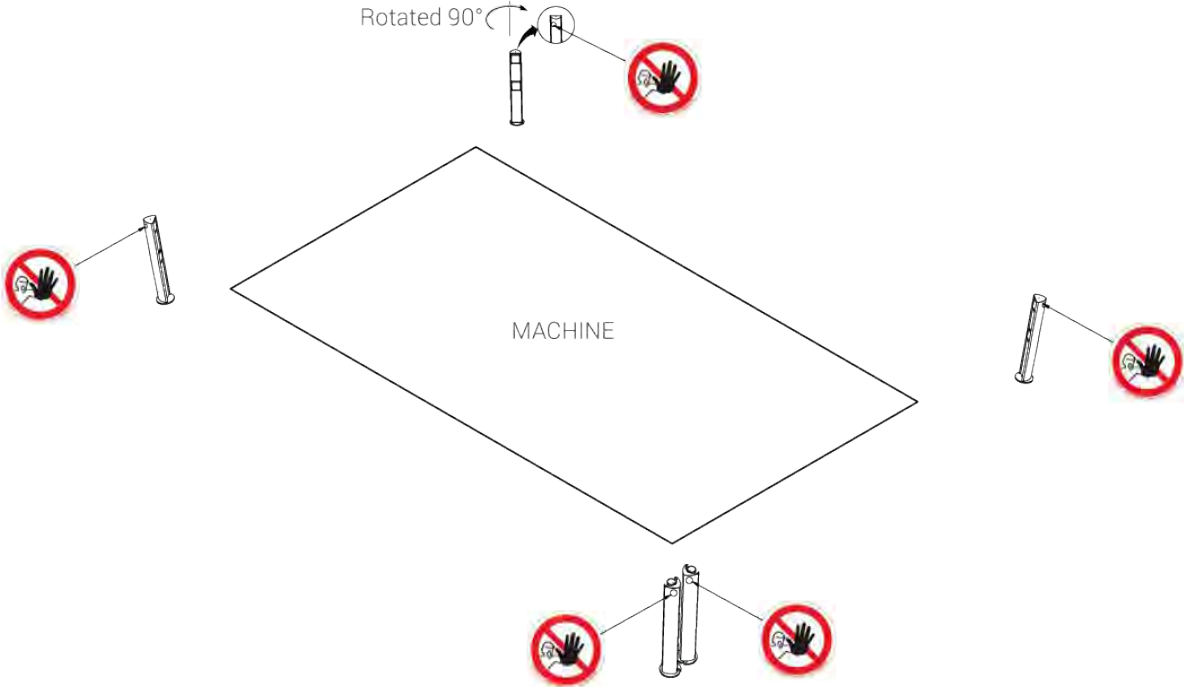



SHAPE TECHNOLOGIES GROUP®

## Introduction to Mach 200

---

The Mach 200 is specifically engineered to deliver value, reliability, and performance. The system is purposefully crafted to be a practical and flexible waterjet solution, featuring tried and true genuine Flow technology. Get capabilities reserved for elite waterjet systems with the Mach 200 — where value meets performance.





## Options

---

Some options may not be available in your area or for a particular configuration. Please contact your regional office for more information.

### Table sizes

Base at 1.3 m, 3 m, 4 m, or 7.3 m  
Bridge at 1.3 m or 2 m

### Catcher tank

Mild steel or stainless steel

### Ultrahigh-pressure pumps

HyPlex Prime rated at 4150 bar (60,000 psi)  
ESL Intensifier rated at 4150 bar (60,000 psi) · 30SA or UltraJet

### Software

FlowCut/FlowPath 2D CAD/CAM package  
FlowXpert 3D CAD/CAM package  
FlowNest geometric nesting module  
FlowCode G-Code converter module

### Cutting heads

Pure Waterjet  
Standard Abrasive Waterjet  
Pivot+ Waterjet

### Ancillary options

#### For the cutting head

UltraPierce Vacuum Assist  
Pivot+ Height Setter

#### For the machine

Light curtains

#### Accessories

Laser pointer  
Low-profile clamps  
ProXtract part removal wand  
Spray containment shields

#### Abrasive delivery/removal products

Abrasive Transfer System (ATS)  
Final Filter System  
100 lb hopper  
2200 lb hopper  
Paser CF900 Abrasive Delivery System (Continuous-fill hopper)

#### Accessories

Supersack stand for hopper

## Component ID

---

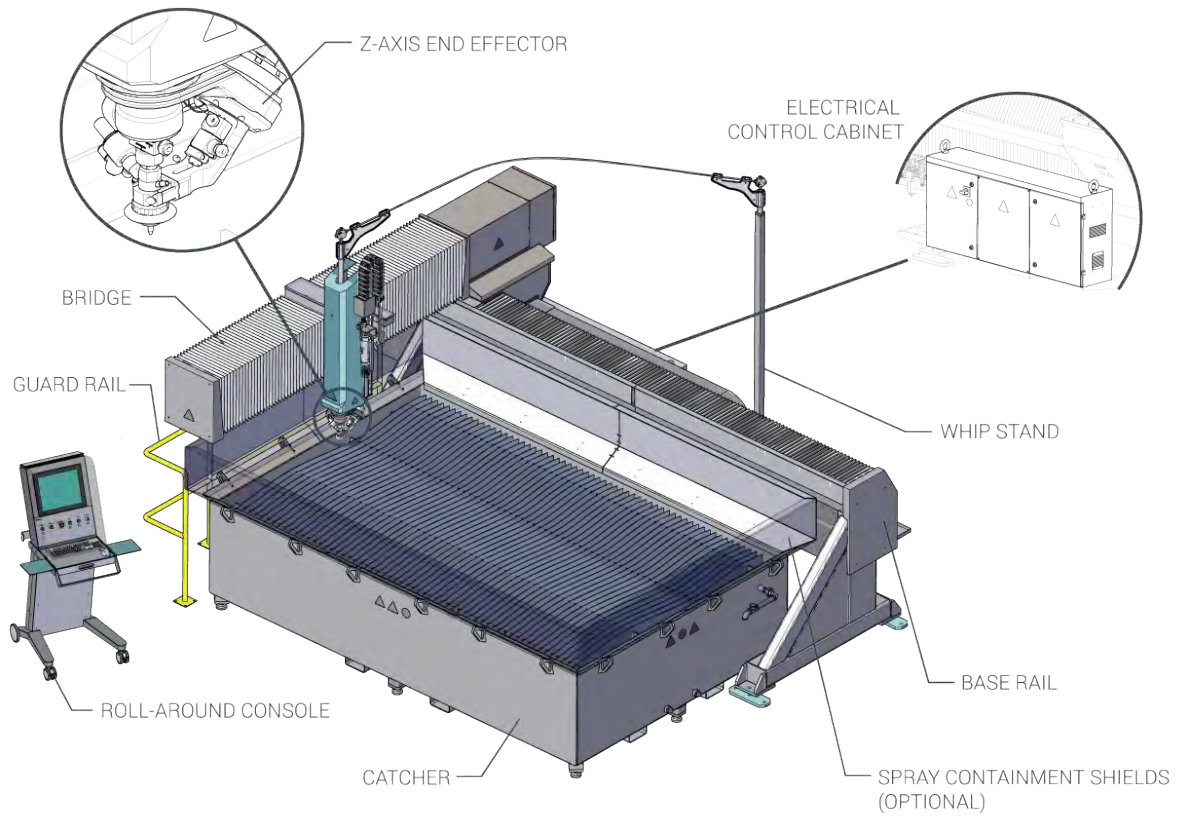



SHAPE TECHNOLOGIES GROUP®

## Facility requirements for Mach 200

---

### Clearances

---

#### 1313 models

- Recommended clearance each side ..... 1000 mm (39 in.)
- Minimum vertical clearance, unobstructed ..... 3033 mm (119 in.)

#### 3020, 4020, or 7320 models

- Recommended clearance each side ..... 1000 mm (39 in.)
- Minimum vertical clearance, unobstructed ..... 4286 mm (169 in.)

### Electrical

---

#### Electrical

- Power supply ..... 3-phase
- Voltage/frequency ..... 480 VAC/60 Hz or 400 VAC/50 Hz
- Main circuit breaker size\* ..... 20 amp

\* For machine only; does not include the high-pressure pump.

### Ethernet connection

---

The maximum cable length for Ethernet connection is 76 m (250 ft). If a longer length of cable is required, you must install a switch near the interface enclosure to amplify the signal. Otherwise, it may not be possible to connect the machine to your network, and this will limit our ability to support the machine via VPN.

## Environment

---

### Facility environment requirements

Ambient temperature .....	15.5°–38°C (60°–100°F)
Recommended temperature .....	20°±3°C (68°± 5°F)
Relative humidity .....	up to 90% @ 38°C (100°F), non-condensing
Airborne dust/contaminants .....	minimal
Radio frequency interference .....	minimal
Lighting .....	adequate to operate and service the machine

### Large temperature changes

If large temperature changes occur within an undefined period, length variances exceeding specified tolerances could occur over the entire work envelope. The tolerances of parts cut in extreme heat will differ from those cut in extreme cold because of variances produced in both the machine's structure and expansion of the actual part.

## Foundation

---

Everything starts with a great foundation and your waterjet is no exception! If you do not have an adequate foundation, the accuracy of your machine is affected.

Your foundation must be:

- Able to support the weight of the machine when the catcher tank is filled with dirty water.
- Free of expansion joints in the area that you plan to put your machine. (The purpose of expansion joints is to concentrate foundation movement and imperfections to these specific areas.)
- Level to 13 mm (1/2 in.) across the span of the machine.
- Structurally reinforced and undivided to ensure even settling, should any settling occur.

In abnormal cases where a poor foundation or unusual soil conditions are present, your machine could require an isolated monolithic foundation of adequate mass to resist both static and dynamic loads imposed by the machine. Consult a local structural engineer to obtain design input based upon your particular soil bearing and floor conditions.

## Machine weight calculations

Model	Clean water	Mild steel · Dirty water	Stainless steel · Dirty water
1313	4903 kg (10,810 lb)	11,104 kg (24,480 lb)	10,278 kg (22,661 lb)
3020	9330 kg (20,569 lb)	25,856 kg (57,024 lb)	22,936 kg (50,565 lb)
4020	11,398 kg (25,129 lb)	32,996 kg (72,745 lb)	29,090 kg (64,133 lb)
7320	18,536 kg (40,866 lb)	57,028 kg (125,726 lb)	49,900 kg (110,011 lb)

## Plumbing

---

### Air

Air supply ..... dry and filtered to 10 microns

Capacity ..... 538 L/min @ 6.9–8.3 bar (19 scfm @ 100–120 psi) per Z-axis end effector\*

Interface type ..... 3/4 in. BSPTF

\*If machine has UltraPierce Vacuum Assist, an additional 538 L/min @ 6.9–8.3 bar (19 scfm @ 100–120 psi) per Z-axis end effector is required.

### Drain

Capacity ..... 8 L/min @ 0 bar (2 gpm at 0 psi) minimum per cutting head

Interface type ..... 1 in. NPT



SHAPE TECHNOLOGIES GROUP®

## Get started: Operation Basics

---

### Get Started: Operation Basics

Pages: 9

- **Specifications for Mach 200**  
Key specifications, including operating parameters for a Mach 200 system.
- **Learn the machine interface**  
Information on the indicator lights and buttons on the current roll-around console.
- **Set-up Mode**  
Learn the DOs and DON'Ts and the INs and OUTs of Set-up Mode.
- **Start-up inspection**  
The purpose of a start-up inspection is twofold: it ensures that your machine is safe to operate, and helps your operators find small problems before they become big ones.
- **Start the machine - (A)**  
Follow these steps to start the machine from a cold start (no power).
- **Emergency stop**  
In an emergency, press the E-stop button on the roll-around console. This article also includes how to reset after an E-stop.
- **Shut down the machine**  
If you have to shut down the machine, follow these steps to do so.
- **Stop or end the part program**  
How to stop or end the part program, including how to start or resume the part program once you have stopped or ended it.
- **Recover from an error**  
When an error occurs during operation, a message appears in FlowCUT. To recover from that error, you'll want to follow these steps to get back to normal operation quickly.



SHAPE TECHNOLOGIES GROUP®

## Specifications for Mach 200

---

### Machine specifications

Z-axis travel .....	203 mm (8 in.)
Catcher tank load rating <sup>1</sup>	
Mild steel .....	1465 kg/m <sup>2</sup> (300 lb/ft <sup>2</sup> )
Stainless steel .....	977 kg/m <sup>2</sup> (200 lb/ft <sup>2</sup> )
Acceleration .....	0.05 G
Contouring speed maximum .....	7620 mm/min (300 in./min)
Rapid traverse maximum .....	10,160 mm/min (400 in./min)
Ballbar circularity .....	± 0.09525 mm (0.00375 in.)
Linear straightness accuracy .....	± 0.0991 mm (0.0039 in.)
Repeatability .....	± 0.051 mm (0.002 in.)

### Operating parameters

Mixing tube for Standard Waterjet .....	4 in. length
Mixing tube for Pivot+ Waterjet.....	3 in. length
Standoff.....	2.54 mm (0.10 in.)
Pivot+ Waterjet .....	60° tilt maximum

### Electrical

Power supply .....	3-phase
Voltage/frequency .....	480 VAC/60 Hz or 400 VAC/50 Hz
Main circuit breaker size <sup>2</sup> .....	20 amp

- 
1. Ratings assume a full table of slats that are in good, like-new condition.
  2. For machine only; does not include the high-pressure pump.



SHAPE TECHNOLOGIES GROUP®

## Learn the machine interface

### Where used

Mach 500 · Mach 300 · Mach 200

### What do the indicator lights mean?



If the indicators are...	State	What does it mean?
Solid White	Standby	Initialization is finished, but all axes are disabled.
Flashing White + Green	Manual	The drives are enabled and you can jog the axes manually and home the machine.
Flashing White + Red	Set-up Mode	The machine is in Set-up Mode.
Solid Green	Automatic cycle	A part program is running.
Solid Red	Shutdown	The machine is stopped due to a fault condition.



## What do all the buttons do?

---



Item	What does it do?
Cycle Stop	Pauses the part program and stops the high-pressure water stream and abrasive flow.
Set-up Mode key switch	See <i>Set-up Mode</i> article.
Emergency stop	Disables the drives, and stops the high-pressure water stream, abrasive flow, and the pump.
Power	Enables the drives.
Reset	Resets the drives.
USB Port	Connection point for peripherals. Keep the USB port covered with the cap when not in use to prevent corrosion.



SHAPE TECHNOLOGIES GROUP®

## Set-up Mode

---

### Where used

Mach 500 · Mach 300 · Mach 200

### Summary

When the machine is in Set-up Mode, you can interrupt the light curtain beam without causing an E-stop condition, jog the axes manually within the preset speed limits, and turn the water and abrasive on or off in FlowCUT. Once the machine is in Set-up Mode, the indicators on the roll-around console continually flash red and white and the pump is in an E-stop condition.

### To put the machine in Set-up Mode

---

To put the machine in Set-up Mode, do the following:

1. Put the machine in Manual state (drives are enabled and you can jog the axes manually).



**You must put the machine in Manual state before you turn the key switch to ON.**

Otherwise, it will cause a machine E-stop condition and you'll get a System: Safety Device/ Light curtain (M934) FlowSENSE error. Pushing the Reset button will not fix the error.

2. On the roll-around console, turn the Set-up Mode key to ON.

### To recover from Set-up Mode error

---

To recover from a Set-up Mode error, follow these steps:

1. Select **Option Component**, and then select **Reset Ethercat (After reset, Cycle E-stop/ Reset/Power Buttons)**.
2. Press and release the E-stop, and then press the Reset button.



SHAPE TECHNOLOGIES GROUP®

## Start-up inspection

---

### Where used

Mach 500 · Mach 300 · Mach 200

### Summary

The purpose of a start-up inspection is twofold: it ensures that your machine is safe to operate, and helps your operators find small problems before they become big ones. This means less unscheduled downtime and fewer repairs which ultimately improves your bottom line!

### Recommended interval

We recommend that you do each inspection at the specified point given when you start your machine.

### Inspections

#### Inspection #1

- There is nothing on or around the table that will impede movement of the axes.
- All cover, panels, and doors on the machine are in place or closed.
- The catcher tank slats are in good, like new condition.

#### Inspection #2

- The air and water supply to the machine are on.
- The inlet water and cooling water supply to the pump are on.

#### Inspection #3

- There is an adequate amount of oil in the pump.
- There is an adequate amount of abrasive in the hopper.
- Inlet water pressure is acceptable.
- Ancillary equipment—such as chillers or abrasive removal systems—are on.

#### Inspection #4

- The pump is at the correct pressure.
- The pump is not leaking.







SHAPE TECHNOLOGIES GROUP®

## Start the machine · (A)

### Where used

Mach 500 · Mach 300 · Mach 200

Follow these steps to start the machine from a cold start (no power):

1. If there is a customer-supplied main disconnect on the wall that supplies power to the machine, make sure that this is switched on.
2. Do Inspection #1:
  - There is nothing on or around the table that will impede movement of the axes.
  - All cover, panels, and doors on the machine are in place or closed.
  - The catcher tank slats are in good, like new condition.
3. Switch on the pump disconnect, and then turn on the main power disconnect switch that is on the machine interface enclosure. Turn on the hopper.
4. Do Inspection #2 of start-up inspection:
  - The air and water supply to the machine are on.
  - The inlet water and cooling water supply to the pump are on.
5. Let the Windows® operating system start. When the connection occurs, the indicator lights turn red.
6. Disengage the E-stop buttons on the roll-around console and the pump.
7. If you have light curtains, press the foot switch to reset them.
8. Press the Reset button, and then press and hold the Power button for two seconds.
9. Open FlowCut, select **Run Machine**, and then home the Z-axis.
10. Manually jog the cutting head to an open area of the table, and then do Inspection #3:
  - There is an adequate amount of oil in the pump and abrasive in the hopper.
  - Inlet water pressure is acceptable.
  - Ancillary equipment—such as chillers or abrasive removal systems—are on.
11. Start the pump in FlowCut, and then do Inspection #4:
  - The pump is at the correct pressure and is not leaking.
12. Under **Water**, click , click , and then make sure that the water stream is concentric.
13. Under **Abrasive**, click , click , and then make sure that the abrasive flows.
14. Open a part file and cut parts!



## Emergency stop

---

### Where used

Mach 500 · Mach 300 · Mach 200

### To do an emergency stop

---

In an emergency, press the E-stop button on the roll-around console. This will disable the drives, the high-pressure water stream, the abrasive, and the pump.



### To reset after an E-stop

---

To reset after an E-stop, follow these steps to get back to normal operation quickly:

1. Make sure that the danger or issue that prompted the emergency stop is fixed or corrected.
2. Disengage the E-stop.
3. Click **OK** on the message.
4. In the **FlowSENSE Diagnostics** dialog box, click **Acknowledge all**, and then click **Close**.
5. Press the **Reset** button—the indicators will turn white.
6. Press and hold the **Power** button until the button illuminates green.



SHAPE TECHNOLOGIES GROUP®

## Shut down the machine

---

### Where used

Mach 500 · Mach 300 · Mach 200

When you shut down the machine, follow these steps:

1. Jog the cutting head to a loading or safe position.
2. Exit all programs.
3. Press the E-stop.
4. Click **Start**, and then click **Shut down** to turn off the machine PC.
5. Wait until the machine PC is completely shut down, and then switch off the main power to the machine (pump and machine disconnect).



SHAPE TECHNOLOGIES GROUP®

## Stop or end the part program

---

### Where used

Mach 500 · Mach 300 · Mach 200

### Start, restart, or resume the part program

---

When you stop the part program, the high-pressure water stream and abrasive flow also stop.

- To stop the part program, select **Cycle Stop** or press the Spacebar. Additionally, you can press the Cycle Stop button on the roll-around console if the console is equipped with one.
- To restart the part program after it was stopped, select **Cycle Start**.
- To resume the part program after it was stopped, do the following:
  1. On the **Cutting** menu, select **Cut from a point**.
  2. Click on the point in the drawing "just before" the location where the program stopped.
  3. When you receive the "Jet will move to this point and start the cut by USING CURRENT HOME POSITION" message, select **Yes**.

### End, restart, or resume the part program

---

When you end the part program, the high-pressure water stream and abrasive flow stop. If you selected the **Automatically turn off pump after cutting** check box in FlowCUT during setup, the pump also stops.

- To end the part program, press the Esc key.
- To restart the part program after you end it, start the pump and then select **Cycle Start**.
- To resume the part program after you end it, do the following:
  1. Start the pump.
  2. On the **Cutting** menu, select **Cut from a point**.
  3. Click the point in the drawing "just before" the location where the program stopped.
  4. When you receive the "Jet will move to this point and start the cut by USING CURRENT HOME POSITION" message, select **Yes**.



SHAPE TECHNOLOGIES GROUP®

## Recover from an error

---

### Where used

Mach 500 · Mach 300 · Mach 200

When an error occurs during operation, a message appears in FlowCUT. To recover from an error, follow these steps:

1. Correct the error.
2. Click **OK** on the message in FlowCUT.
3. In the **FlowSENSE Diagnostics** dialog box, click **Acknowledge all**, and then click **Close**.
4. Press the **Reset** button—the indicator lights will turn white.
5. Press and hold the **Power** button until the button illuminate green.





SHAPE TECHNOLOGIES GROUP®

## Recommended maintenance schedule

---

### Where used

Mach 500 · Mach 300 · Mach 200 · Mach 100

We recommend that you keep a log of all maintenance work that is done on your machine.

What do I do?	When do I do it?
Start-up inspection	Daily
Inspect the mixing tube.	Daily
Spray the mixing chamber vent with clean water.	Every four hours of operation
Clean the cutting head with air.	Weekly
Dynamic Waterjet height sensor calibration	Weekly
Dynamic Waterjet straightness adjustment	Weekly (See FlowCUT help files for instructions.)
Clean and inspect the bellows for rips.	Monthly
Lubricate the bearings and linear rails.	Every 120 hours of operation
Clean the linear rails.	Every 120 hours of operation
Clean the diamond orifice and nozzle nut.	Every 250 hours of operation
Replace the diamond orifice.	As required
Call Flow to schedule a ballbar test.	Every six months



SHAPE TECHNOLOGIES GROUP®

## Torque specification

---

If a torque value for a gland nut is not specified, reference this table to determine torque value.

- Always leave 3–4 threads showing between the end of the high-pressure tubing and gland nut collar.
- Always lubricate threads and the area between the gland nuts and collars with Blue Lubricant.

If the high-pressure tubing OD is...	Then torque the gland nut to...
1/4 in.	20–34 N-m (15–25 ft-lb)
3/8 in.	47–60 N-m (35–45 ft-lb)
9/16 in.	80–100 N-m (60–75 ft-lb)



SHAPE TECHNOLOGIES GROUP®

## Abrasive metering valve overview

---

### Where used

Mach 500 · Mach 300 · Mach 200 · Mach 100

The abrasive metering valve has four main components: an air isolator, an abrasive on/off valve, an abrasive metering disk, and a diverter.



## Air isolator

---

Abrasive and air enter the abrasive inlet port together. The abrasive builds up on top of the isolator and falls through the hole in the center, which separates most of the air from the abrasive. The air is vented out of the top of the metering valve, and the abrasive that falls through the isolator builds up in the lower half of the valve. The remaining entrained air collects in a pocket under the air isolator and is vented from the side of the valve body.

## Abrasive on/off valve

---

An air-actuated on/off valve controls abrasive flow to the metering disk. This double-acting air cylinder requires air pressure at the bottom to open, and at the top to close. In the ON position, the rubber stopper is raised above the seating surface, and abrasive flows through the metering orifice. In the OFF position, the rubber stopper is pushed against the seating surface, which stops the flow of abrasive.

**NOTICE** The metering system regulator requires air pressure of 20–30 psi to close. Failure to operate the valve at the correct pressure will cause the rubber stopper to fail prematurely.

## Abrasive metering disk

---

The metering disk controls abrasive flow to the cutting head. Each disk is marked with the opening diameter, which correlates to flow rate. Flow rate is affected by abrasive type and size, and operates on the principal that a fixed amount of material will flow through a fixed orifice at a constant rate.

For a given waterjet operating pressure, each mixing tube/orifice combination has an optimum abrasive flow rate (using a larger or smaller disk may increase the cost per inch). We recommend that you experiment and adjust the abrasive flow for the material being cut. This will help find the optimum abrasive flow to produce the desired quality of cut with the minimum amount of abrasive while meeting required cycle times.

## Diverter

---

The diverter performs three main functions:

- Holds the metering disk
- Provides a connection to the abrasive feed line
- Redirects water sent up the abrasive feed line away from the metering valve in the case nozzle gets plugged, which keeps the abrasive dry



SHAPE TECHNOLOGIES GROUP®

## Cleaning out a clogged metering valve

---

### Where used

Mach 500 · Mach 300 · Mach 200 · Mach 100

To clean out a clogged metering valve, do the following:

1. Turn off the abrasive hopper.



**CAUTION!** Failure to off the abrasive hopper before you remove the metering valve could cause abrasive to be expelled with the compressed air, causing injury.

2. Twist the knurled aluminum piece on the lower half of the metering valve clockwise, and then remove the piece and allow the abrasive to empty out.
3. Remove any abrasive or moisture that is present on the components. Do not reuse the abrasive!
4. Reassemble the metering valve. Make sure to install hand-tight only or else you risk cracking the body if you overtighten it.
5. Turn on the abrasive hopper and resume operation.



SHAPE TECHNOLOGIES GROUP®

## How to change the abrasive metering disk

---

### Where used

Mach 500 · Mach 300 · Mach 200 · Mach 100

### Summary

Metering disks are engineered to provide correct abrasive flow. To change the flow rate, select the appropriate metering disk, insert it, and continue cutting.

To change the abrasive metering disk, do the following:

1. Twist the diverter clockwise, then carefully pull down to remove it from the main body.
2. Remove the metering disk from the top of the diverter. Clear off abrasive from the top of the diverter.
3. Put a new metering disk in place, then insert the diverter into the body. Turn the diverter counterclockwise to lock it into place.





SHAPE TECHNOLOGIES GROUP®

## Recommended cleaners and lubricants

---

We recommend that you use the following lubricants and cleaners for your machine.

### **Rails**

CRC Technical Grade 3-36® Multi-purpose Precision Lubricant or equivalent cleaner

### **Bellows and painted surfaces**

Johnson Envy Instant Cleaner or equivalent

### **Bearings and linear rails**

Mach 100 ..... Shell Tonna S2 M 68

Mach 200, Mach 300, or Mach 500 ..... AFF Grease



SHAPE TECHNOLOGIES GROUP®

## Clean the linear rails

---

### Where used

Mach 500 · Mach 300 · Mach 200 · Mach 100

### Recommended maintenance interval

Every 120 hours of operation

### Supplies

- Clean, lint-free cloth
- CRC Technical Grade 3-36® Multi-purpose Precision Lubricant or equivalent cleaner

To clean the linear rails, do the following:

1. Pull back all the bellows.
2. Spray a light, even layer of cleaner on the rails.
3. Allow time for the cleaner to penetrate the dirt and grease, and then remove it with a clean, lint-free cloth.
4. Put the bellows back in place.





SHAPE TECHNOLOGIES GROUP®

## Inspect and clean the bellows

---

### Where used

Mach 500 · Mach 300 · Mach 200 · Mach 100

### Recommended maintenance interval

Monthly

### Supplies

- Clean, lint-free cloth
- Johnson Envy Instant Cleaner or equivalent

To inspect and clean the bellows, do the following:

1. Inspect the bellows for rips and tears.
2. Spray a light, even layer of foam cleaner on the surface of the bellows.
3. Allow time for the cleaner to penetrate the dirt and grease, and then remove it with a clean, lint-free cloth.
4. Repeat steps 2– 3 as necessary.



SHAPE TECHNOLOGIES GROUP®

## Lubricate the bearings and linear rails · (B)

---

### Where used

Mach 200

### Recommended maintenance interval

Every 120 hours of operation

### Good to know!

Z-axis rails do not require lubrication.

### Tools

- Hex key
- MG70 grease gun (supplied with machine)
- Phillips screwdriver

### Supplies

- AFF Grease cartridge · A-31748-1
- Clean, lint-free cloth
- Sheet of plywood

### Grease points

View: User faces the front of the machine.

X-axis bearings ..... Bridge, rear side, center  
X-axis ball nut ..... Motor drives enclosure, rear side  
Y-axis bearings ..... Right riser, rear side  
Y-axis ball nut ..... Right base rail  
Z-axis ball nut ..... Z-axis enclosure

To lubricate the bearings and linear rails, do the following:

1. Put a sheet of plywood on the catcher tank so that objects do not fall into the tank while you lubricate the bearings and linear rails.
2. Remove the X and Y axes access panels with a Phillips screwdriver.
3. Remove the Z-axis cover, and then remove the access panel with a hex key.
4. Locate the Zerk fitting for each ball nut. If necessary, jog the machine until the Zerk fittings are accessible.
5. Do a Lockout/Tagout (LOTO) for the machine.
6. Lubricate each ball nut with three pumps of grease from the grease gun.
7. Lubricate the bearings with three pumps of grease from the grease gun.
8. Install the X and Y axes access panels with a Phillips screwdriver.
9. Install the Z-axis access panel with a hex key, and then install the Z-axis cover.



SHAPE TECHNOLOGIES GROUP®

## Cutting head overview

---

### Where used

Mach 500 · Mach 300 · Mach 200 · Mach 100

### How it works · Abrasive cutting

The cutting head accelerates the abrasive with a high-velocity waterjet to generate a stream capable of cutting any material.

When the on/off valve is enabled, high-pressure water flows through the orifice assembly. This creates a high-velocity stream that passes into the mixing chamber, creating an area of partial vacuum. The vacuum draws a metered flow of abrasive through the abrasive delivery line, where it combines with the water to create a high-energy abrasive cutting stream.

This stream exits the cutting head through the mixing tube at a tip velocity of up to 3000 ft/sec (914 m/sec). After cutting, the residual energy of the abrasive stream is contained and dissipated by a catcher.



## Cutting head components

---

The main components of the cutting head are described below. Note that some cutting head assemblies include the on/off valve assembly while others do not. For more information on on/off valves, please see [On/off valve repair](#).

### Nozzle body

The nozzle body has two main functions: it contains the high-pressure water, and it aligns and holds the orifice assembly in the cutting head.



### Orifice

The orifice creates the high-velocity water jet. The orifice and its precision-engineered mount provide a wear-resistant and accurate orifice assembly. The mount is designed to automatically align the orifice with the mixing tube. It will not swage or jam into the body, and no special tools are required to install it.



### Mixing chamber

The mixing chamber introduces abrasive into the water stream. Mixing chambers have a carbide insert installed into the housing below the orifice. This insert helps protect the orifice from becoming damaged due to splash back produced when the waterjet turns off. For easy access, orient the vent on the mixing chamber toward the front of the machine.



### Mixing tube

The ring on the upper part of the mixing tube—in conjunction with the collet, spacer, and nozzle nut—sets the axial location of the mixing tube.



**Mixing tube spacer**

The mixing tube spacer maintains tool length by setting the proper distance of the mixing tube inside the mixing chamber.

**Collet**

The collet aligns the mixing tube with the orifice and locks the mixing tube in place.

**Nozzle nut**

The nozzle nut holds the mixing tube, collet, and mixing tube spacer inside the mixing chamber.

**Spray shield**

The flexible spray shield snaps into the nozzle nut, and surrounds the mixing tube to help contain jet spray during piercing. The cutting head is designed to be used with a spray shield—do not operate without the spray shield in place.



To replace the spray shield, slip it over the slight step on the nozzle nut and then slide the spray shield over the mixing tube. Slide the blast disk over the mixing tube; press into the center of the spray shield.

**Blast disk**

A wear-resistant polyurethane blast disk in the center of the spray shield absorbs most of the jet's energy, and helps to extend the life of the spray shield.





SHAPE TECHNOLOGIES GROUP®

## Cutting head assembly · 041136-1

---

### Description

Abrasive cutting head assembly. Does not include mixing tube or orifice.



### Maximum operating pressure

6000 bar (87,000 psi)

### Where used

Mach 500 ..... Standard or Dynamic Waterjet  
 Mach 300 ..... Standard or Dynamic Waterjet  
 Mach 200 ..... Standard Waterjet  
 Mach 100 ..... Standard Waterjet

### Flow Parts for cutting head

#### A-M

Blast disk ..... 711933-1  
 Collet ..... 710806-1  
 Mixing chamber ..... 041138-1  
 Mixing chamber cap ..... A-11080  
 Mixing tube · DELTA NXT Premium ..... 1000003-XX-40  
 Mixing tube · DELTA Standard ..... 1000001-XX-40  
 Mixing tube spacer ..... 712265-1

#### N-Z

Nozzle body ..... 041137-1  
 Nozzle nut ..... 711589-1  
 O-ring ..... A-15034-1  
 Orifice · Diamond ..... 015849-XX  
 Orifice · Ruby (60K pumps only) ..... 041759-XX  
 Spray shield ..... 040411-1  
 V-ring seal ..... A-22752-11



SHAPE TECHNOLOGIES GROUP®

## Cutting head assembly · 060009-1

---

### Description

Abrasive cutting head assembly; includes on/off valve assembly. Does not include mixing tube or orifice.



### Maximum operating pressure

4150 bar (60,000 psi)

### Where used

Mach 200 ..... Pivot+ Waterjet

### Flow Parts for cutting head

#### A–M

Blast disk ..... 058211-1  
 Collet ..... 710806-1  
 Mixing chamber ..... 060017-1  
 Mixing chamber cap ..... A-11080  
 Mixing tube · DELTA NXT Premium ..... 1000004-XX-30  
 Mixing tube · DELTA Standard ..... 1000002-XX-30

#### N–Z

Nozzle body ..... 060010-1  
 Nozzle nut ..... 014241-1  
 O-ring ..... A-15034-1  
 O-ring ..... A-0275-108  
 O-ring ..... A-0275-209  
 Orifice · Diamond ..... 015849-XX  
 Orifice · Ruby (60K pumps only) ..... 041759-XX  
 Spray shield ..... 058212-1





SHAPE TECHNOLOGIES GROUP®

## Cutting head assembly · 042153-10

---

### Description

Water-only cutting head assembly



Flow

### Maximum operating pressure

6000 bar (87,000 psi)

### Where used

- Mach 500 ..... Standard or Dynamic Waterjet
- Mach 300 ..... Standard or Dynamic Waterjet
- Mach 200 ..... Standard Waterjet

### Flow Parts for water-only cutting head

- Nozzle body ..... 041154-1
- Nozzle retainer ..... B-1041-1
- Orifice · Diamond ..... D-5071-XX
- Orifice · Sapphire ..... 004519-XX



SHAPE TECHNOLOGIES GROUP®

## Cutting head assembly · 061015-1

---

### Description

Water-only cutting head; does not include orifice.

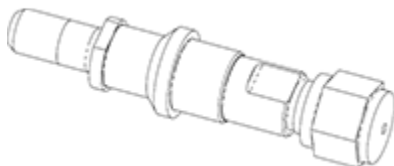

### Where used

Mach 200 ..... Pivot+ Waterjet

### Flow Parts for water-only cutting head

Nozzle body ..... 061009-1  
Nozzle retainer ..... 061014-1  
Orifice · Diamond ..... D-5071-XX  
Orifice · Sapphire ..... 004519-XX



SHAPE TECHNOLOGIES GROUP®

## Flush the mixing chamber vent

### Where used

Mach 500 · Mach 300 · Mach 200 · Mach 100

### Recommended maintenance interval

Every four hours of operation

### Summary

Flush the mixing chamber vent with clean water to minimize residue buildup.

(Picture shown for general reference only and may vary from your machine model.)

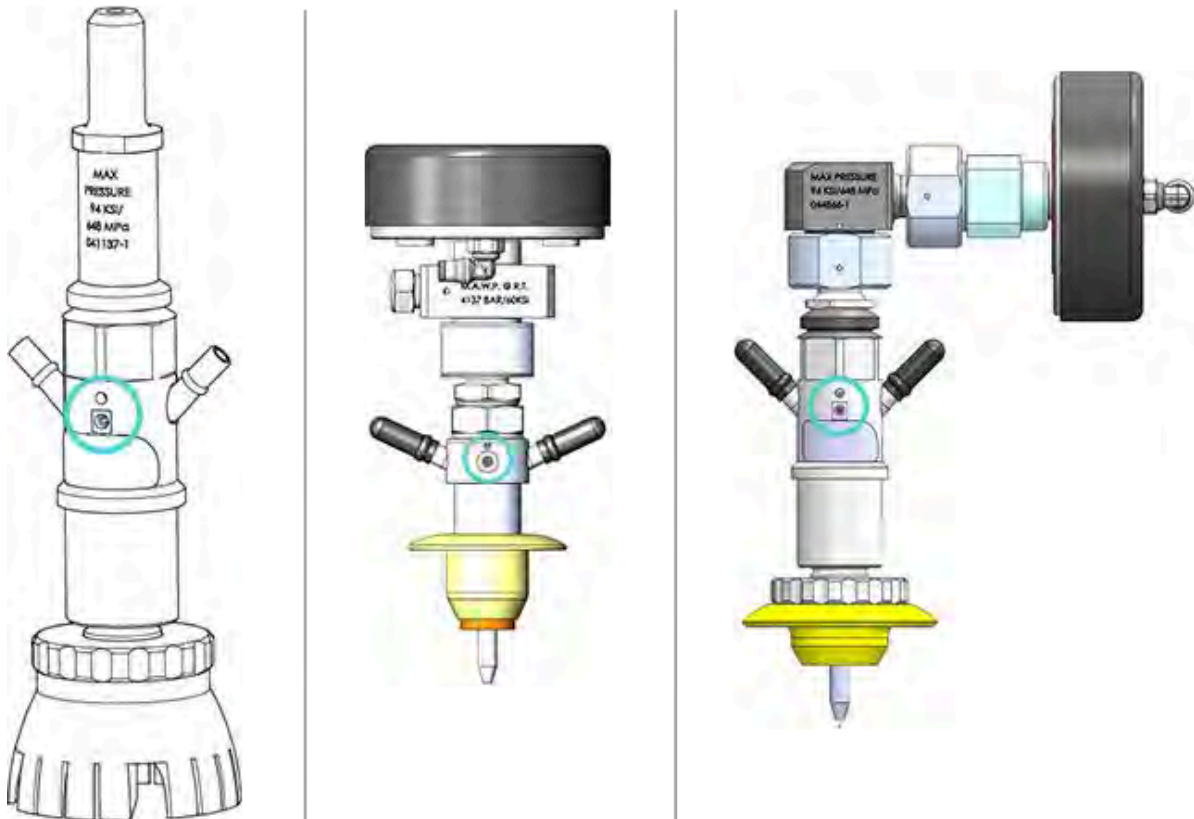



SHAPE TECHNOLOGIES GROUP®

## Inspect the mixing tube

---

### Where used

Mach 500 · Mach 300 · Mach 200 · Mach 100

### Recommended maintenance interval

Daily

### Summary

Inspect your mixing tube daily so you can monitor and limit ID growth. Note that the mixing tube is brittle carbide. Do not bend, drop, or twist it. Replace the mixing tube if it shows any of the following conditions:

- Prominent, off-center wear at the nozzle exit tip ID.
- Chips in the downstream end, outside edge of the nozzle that originate at the outside diameter and leave less than 0.020 in. (0.508 mm) nozzle wall thickness.
- Cracks that extend radially from the nozzle ID to OD, or that extend down the length of the nozzle.
- Chips in either end of the nozzle that originate at the inside diameter.



SHAPE TECHNOLOGIES GROUP®

## Clean the diamond orifice and nozzle nut

---

### **Where used**

Mach 500 · Mach 300 · Mach 200 · Mach 100

### **Recommended maintenance interval**

Every 250 hours or any time you experience degraded waterjet quality.

To clean the diamond orifice or nozzle nut, do the following:

1. Soak the part in an ultrasonic cleaning bath for approximately 5–10 minutes and then remove the part from the ultrasonic bath and thoroughly dry with pressurized air.
2. Use a high-power camera or microscope to inspect the part. Verify that no residue or debris remains.



SHAPE TECHNOLOGIES GROUP®

## Replace the diamond orifice

---

### Where used

Mach 500 · Mach 300 · Mach 200 · Mach 100

### Recommended maintenance interval

As required

### Tools

Torque wrench with crows foot attachment

### Supplies

Blue Lubricant

Clean, lint-free applicator

Clean, lint-free cloth

To replace the diamond orifice, do the following:

1. Make sure that the high-pressure pump is off and bleed down all pressure from the system.
2. Pull firmly on the abrasive feed line to remove it from the cutting head, and then open the cutting head clamp.
3. Using a 1-1/8 in. wrench on the mixing chamber and a 7/8 in. wrench on the nozzle body, separate the mixing chamber and nozzle body.
4. Tap the mixing chamber upside down on a table to remove the orifice assembly. If necessary, lightly pry on the mount with a screwdriver.
5. Clean the mixing chamber to remove abrasive and debris.

6. Examine the carbide insert that is in the mixing chamber. Replace the mixing chamber if you find the following:
- Evidence of erosion, wear, or other damage such as pitting
  - Hole is oblong shape instead of round
  - Diameter of the hole is larger than 1.8 mm (0.07 in.)

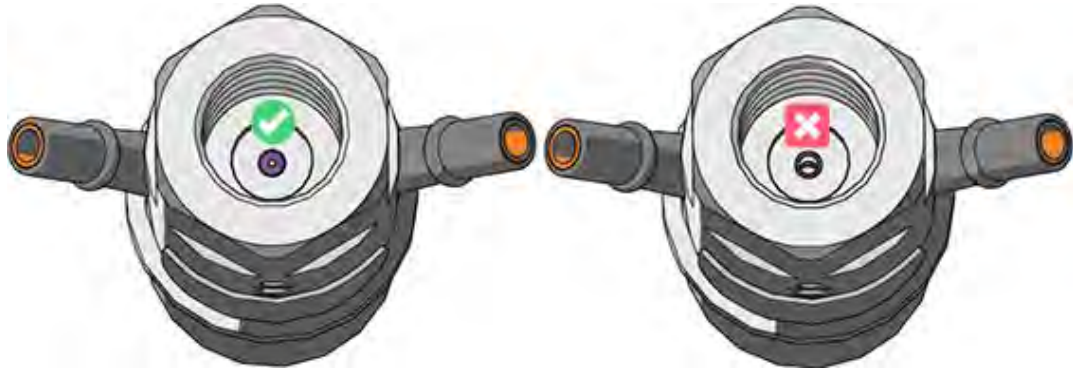

7. Apply a thin, even layer of BLUE LUBRICANT on the angled surface of the orifice assembly with a clean, lint-free applicator.

**NOTICE** Do not over-tighten the cutting head—it will damage mating surfaces and the orifice mount. Such damage is not covered by warranty.

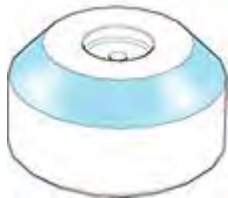

8. Make sure that the seating surface that is in the mixing chamber is free of abrasive and debris, and then drop the orifice assembly—flat face down, taper side up— into the recess of the body.
9. Apply a thin, even layer of BLUE LUBRICANT to the threads of the nozzle body. Attach the mixing chamber body to the nozzle body, and then tighten to 41–48 N-m (30–35 ft-lb).
10. Clean the top surface of the cutting head clamp with a clean, lint-free cloth to remove abrasive and debris.
11. Put the cutting head assembly in the clamp. Before you close the clamp, make sure that the flat on the cutting head sits flush with the top of the clamp.
12. Connect the abrasive feed line.



SHAPE TECHNOLOGIES GROUP®

## On/off valve overview

---

### Where used

Mach 500 · Mach 300 · Mach 200 · Mach 100

### How it works

The on/off valve is a pneumatically actuated valve that opens and closes the high-pressure water line, thus controlling water flow to the cutting head and nozzle.

### Tip for increasing the life of on/off valve parts

After replacing high-pressure plumbing or other equipment on your high-pressure pump, flush the system directly into the catcher tank before running the high-pressure water through the on/off valve and orifice. This will help minimize debris in the high-pressure lines that could damage the valve or orifice.





SHAPE TECHNOLOGIES GROUP®

## On/off valve · 014553-1

---

### Description

On/off valve assembly

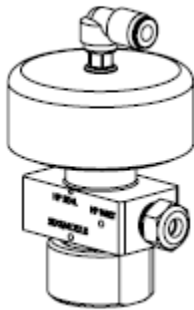

### Maximum operating pressure

4150 bar (60,000 psi)

### Where used

Mach 200 ..... Standard Waterjet  
Mach 100 ..... Standard Waterjet

### Maintenance and tool kits

On/off valve seal kit ..... 014988-1  
On/off valve tool kit ..... 019623-1

### Reference

[Troubleshooting the on/off valve](#)  
[Install on/off valve seal kit · 014988-1 \(D\)](#)



SHAPE TECHNOLOGIES GROUP®

## On/off valve · 060647-1

---

### Description

Low-profile on/off valve assembly



### Maximum operating pressure

4150 bar (60,000 psi)

### Where used

Mach 200 ..... Pivot+ Waterjet

### Maintenance and tool kits

On/off valve seal kit ..... 014988-1

On/off valve tool kit ..... 019623-1

### Reference

[Troubleshooting the on/off valve](#)

[Install on/off valve seal kit · 014988-1 \(C\)](#)



SHAPE TECHNOLOGIES GROUP®

## Troubleshooting the on/off valve

---

### Where used

On/off valve ..... 014553-1 · 014660-2 · 060647-1

### Summary

There are two main failure modes for the on/off valve: leaking water (most common) or an on/off valve that does not open or close correctly. Pay special attention to the utility connections and air lines—the high-pressure water supply could be partially blocked, or there could be bends, holes, or loose connections in the air lines.

After you troubleshoot the on/off valve, it could seem like you only have to replace one or two parts from the seal kit. However, all seal kit components have similar expected life times. **If one component failed, the others are also likely to fail very soon!** We recommend that you install all seal kit components at the same time to reduce maintenance time and machine downtime.

### Water leaks past the high-pressure assembly (top of high-pressure seal)

---

#### Drips every few cycles

This indicates seal and backup ring wear. It's OK to continue to operate the machine, but if the leak causes problems, install the seal kit now. (Part #014988-1)

#### Steady trickle

This indicates moderate seal and backup ring wear. Install the seal kit next time the machine is down.

#### Shooting stream

This indicates a failed O-ring or severe seal and backup ring wear. Install the seal kit immediately!

### Water leaks from the tubing/valve body (high-pressure inlet)

---

#### Streaming

This indicates the ¼ in. gland is not tight. Turn off the high-pressure pump, and then tighten the ¼ in. gland.

#### Shooting stream

This indicates there is a crack in the high-pressure port of the valve body or tubing. You must replace the valve body or the tubing.

## Water leaks from the valve body or seat, or from the seat or nozzle body interface.

---

### Streaming

This indicates the nozzle body gland is not tight. Turn off the high-pressure pump, and then tighten the gland.

### Shooting stream

This indicates there is a cracked valve body, seat, or nozzle body. You must replace the cracked parts.

## On/off valve does not open

---

If the on/off valve does not open, do the following:

- Make sure the shop air supply is on, correctly connected, and the pressure is 90–100 psig (6–7 bar) at the actuator. Check for kinks, breaks, and holes in the air line. Pull the line off the fitting, and then manually turn the air on in FlowCUT to make sure that air is coming through.
- Make sure the controller signals the valve to open.
- Lack of high-pressure water can cause the on/off valve to not open. Make sure the pump is running and if installed, all manual shut-off valves are open.
- Check for a blockage in the lines:
  1. Turn off the pump, and if installed, close the manual shut-off valves.
  2. Disconnect the high-pressure water line from the valve, aim it into the catcher tank, and then secure it.
  3. If installed, open the manual shut-off valves. Turn the pump on.
  4. If there is a steady stream of high-pressure water going into the catcher tank, there is no blockage. If the water stream is erratic, this indicates there is a blockage in the lines.
- Check for a failed actuator or valve seal. Keep the high-pressure water on and manually switch the air on and off. If the fitting or cap on top of the actuator does not move up and down, there is a problem with the actuator. Call Flow Service! If the fitting or cap does move up and down, but the valve still does not open, it could be a failed valve seal. Replace the seal assembly.

## On/off valve does not close

---

If the on/off valve does not close, do the following:

- Try manually switching the air on and off or disconnecting the air line to see if the valve will close. There may be a problem with your software program or controller command to turn the air off.
- Check for a failed valve seal. If the fitting or cap on the actuator moves up and down, but the valve still does not open, it could be a failed valve seal. Replace the seal assembly.



SHAPE TECHNOLOGIES GROUP®

## Install on/off valve seal kit · 014988-1 (C)

---

### Where used

Mach 200 ..... Pivot+ Waterjet

### Recommended maintenance interval

As required

### About this procedure

After you troubleshoot the on/off valve, it could seem like you only have to replace one or two parts from the seal kit. However, all seal kit components have similar expected life times. **If one component failed, the others are also likely to fail very soon!** We recommend that you install all seal kit components at the same time to reduce maintenance time and machine downtime.

When working on high-pressure components, it is critical that you use backup wrenches. Excessive torque on the cutting head can damage the wrist motors. Such damage will void your warranty.

### On/off valve seal kit · 014988-1 parts

- 1 Backup ring ..... 014555-1
- 1 O-ring ..... A-0275-014
- 1 O-ring ..... B-8075-005
- 1 Poppet ..... 014557-1
- 1 Poppet seat ..... 014558-1
- 1 Seal ..... 014556-1

### Tools

- On/off valve tool kit · 019623-1
- 5 mm hex key
- Crescent wrenches
- Soft-jaw vise

### Supplies

- Blue Lubricant
- White Food Grade Grease

## View 1

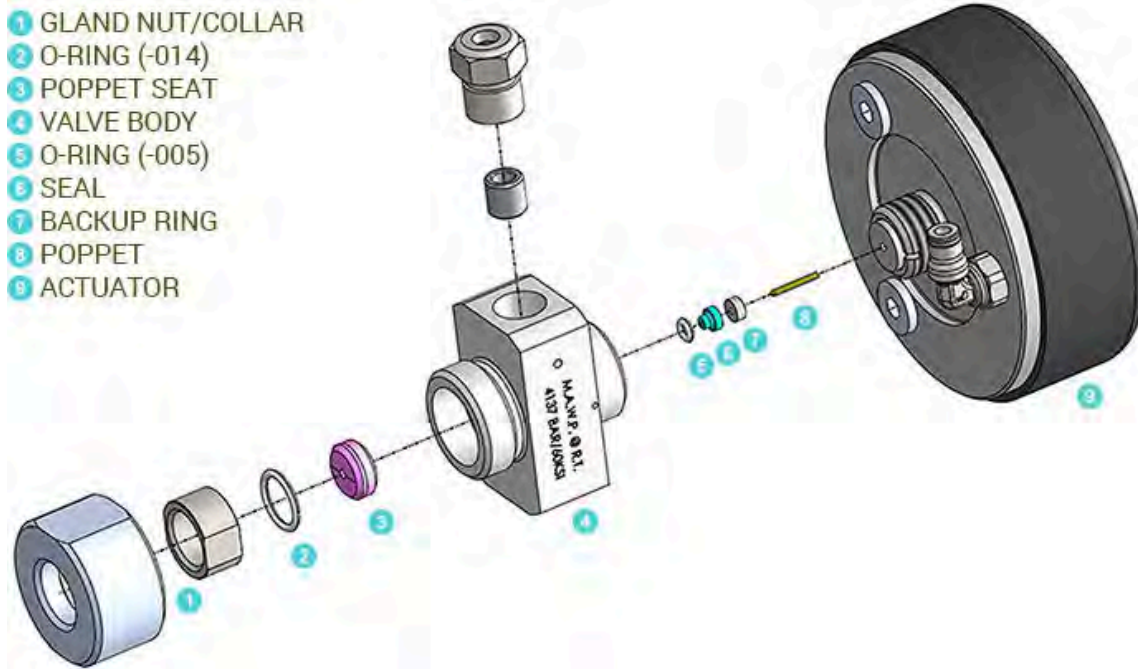

## Part 01

1. Go to **Cutting > Jog to a point** and rotate the B-motor 45° clockwise so the top of the cutting head is facing towards you.
2. Do a Lockout/Tagout (LOTO) for the machine.



**WARNING!** Failure to properly shut down the system could result in injury to personnel or equipment damage.

3. Turn off the supply air, and then disconnect the pneumatic line and high-pressure tubing from the valve.
4. Place a tray under the cutting head to catch any parts.
5. Open the clamp slightly with a 5 mm hex key, and then remove the cutting head assembly. Take the assembly to a clean work area for repair.

## Part 02

---

1. Apply a minimum of 5.5 bar (80 psi) shop air to the actuator to open the valve.
2. Put the assembly in a soft-jaw vise, and then remove the gland nut from the valve body. This will separate the on/off valve assembly from the cutting head and expose the poppet seat.
3. An O-ring helps hold the poppet seat in place. Remove the O-ring, and the poppet seat should come out of the valve body. If it doesn't, use the seal installation tool to help loosen the seat.

 O-ring · Poppet seat

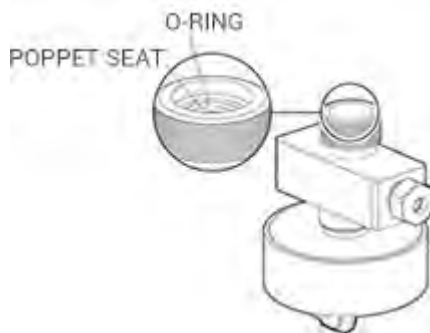

4. Remove the valve body from the actuator, and then set the actuator aside.
5. Place the seal installation tool against the tip of the poppet, and then push the poppet out of the valve body. The bearing, seal, O-ring, and backup ring should also come out with the poppet. If they don't, push these parts out of the valve body in the same direction as you pushed the poppet.

 Poppet · Seal · O-ring · Backup ring

 Bearing

6. Thoroughly clean the valve body, gland nut, and collar with solvent and then dry the parts with shop air.

## Part 03

---

1. Thread the seal guide tool into the valve body.



2. Apply a thin, even layer of WHITE FOOD GRADE GREASE to the poppet, O-ring, seal, and backup ring and then assemble the parts on the seal installation tool as follows:
  - a. Slide the bearing onto the poppet, and then install the backup ring onto the poppet.
  - b. Install the -005 O-ring onto the seal, and then install the seal—O-ring toward the poppet's point—onto the poppet.

▣ The seal assembly should be approximately centered on the length of the poppet.

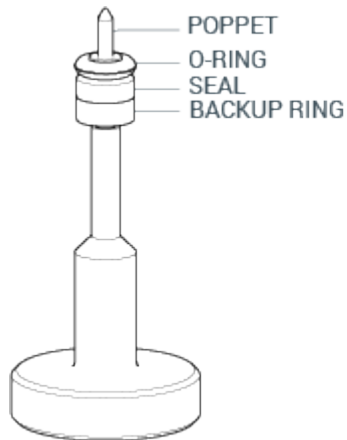



3. Install the poppet/seal assembly—pointed end first—into the actuator end of the valve body. Remove the seal guide tool.

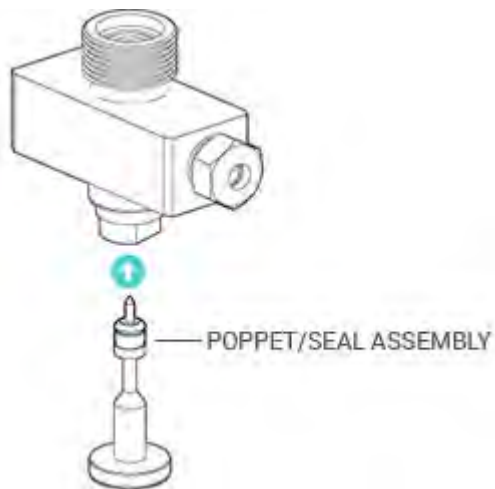

4. Apply a thin, even layer of BLUE LUBRICANT to the actuator threads, and then install the actuator to the valve body.



5. Apply a thin, even layer of BLUE LUBRICANT to the both sides of the poppet seat. Install the poppet seat—such that the small hole faces toward the poppet—into the valve body. Install the -014 O-ring into the groove to hold the poppet seat in place.



6. Apply a thin, even layer of BLUE LUBRICANT to the external threads of the valve body, and then thread it onto the nozzle body by tightening the gland nut. Leave this connection hand tight for now.



## Part 04

---

1. Connect a pneumatic line to the on/off valve assembly, and then turn the air on [5.5 bar (80 psi) minimum] to open the valve.

▣ Open the valve before you tighten the connection to reduce the possibility of galling between the poppet/seat. It also reduces the amount of force required as you are not working against the high spring force of the actuator.



2. Tighten the connection between the nozzle body and the collar to 47–54 N-m (35–40 ft-lb).  
▣ Make sure that you do not rotate the cutting head!
3. Turn off the air to close the valve, and then remove the pneumatic line.
4. Install the cutting head assembly into the clamp, and then do the following:
  - a. Align the cutting head with the high-pressure tubing, and then connect the high-pressure tubing.
  - b. Tighten the clamp with a 5 mm hex key.
5. Connect the pneumatic line to the valve, and then turn on the supply air.
6. **Start the machine.** When you start the pump, start at low pressure and check for leaks. Then turn the pump to high pressure and check for leaks. When finished, manually actuate the valve a few times to make sure it is operating correctly.



SHAPE TECHNOLOGIES GROUP®

## Install on/off valve seal kit · 014988-1 (D)

---

### Where used

Mach 200 ..... Standard Waterjet

Mach 100 ..... Standard Waterjet

### Recommended maintenance interval

As required

### About this procedure

After you troubleshoot the on/off valve, it could seem like you only have to replace one or two parts from the seal kit. However, all seal kit components have similar expected life times. **If one component failed, the others are also likely to fail very soon!** We recommend that you install all seal kit components at the same time to reduce maintenance time and machine downtime.

When working on high-pressure components, it is critical that you use backup wrenches. Excessive torque on the cutting head can damage the wrist motors. Such damage will void your warranty.

### On/off valve seal kit · 014988-1 parts

- 1 Backup ring ..... 014555-1
- 1 O-ring ..... A-0275-014
- 1 O-ring ..... B-8075-005
- 1 Poppet ..... 014557-1
- 1 Poppet seat ..... 014558-1
- 1 Seal ..... 014556-1

### Tools

- On/off valve tool kit · 019623-1
- Crescent wrenches
- Soft-jaw vise

### Supplies

- Blue Lubricant
- White Food Grade Grease

## View 1

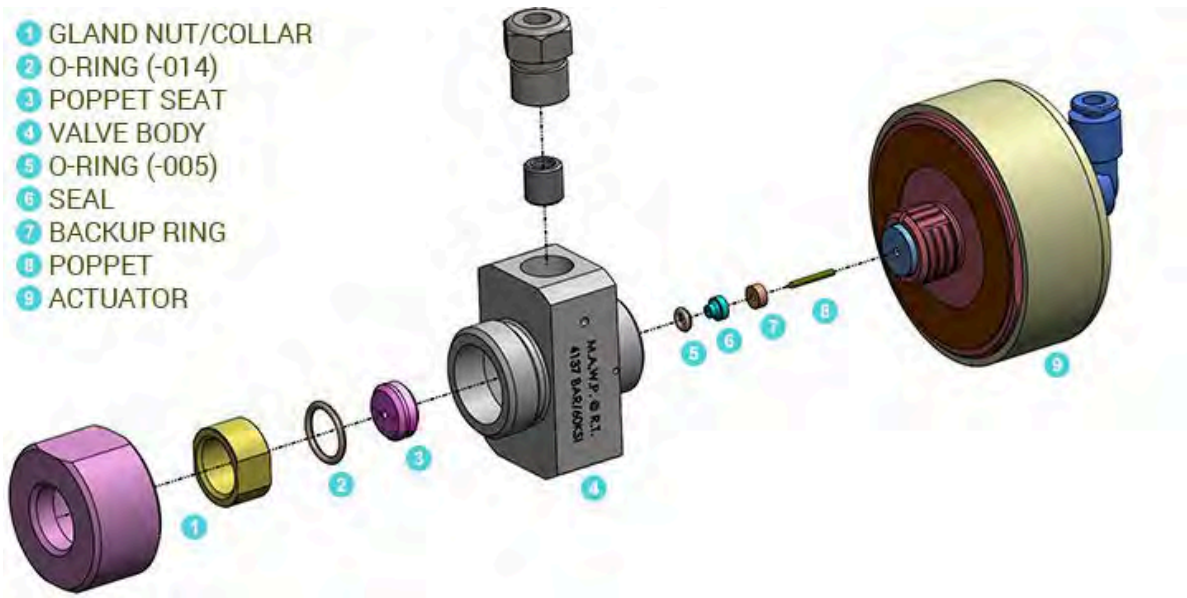

## Part 01

1. Do a Lockout/Tagout (LOTO) for the machine.



**WARNING!** Failure to properly shut down the system could result in injury to personnel or equipment damage.

2. Turn off the supply air, and then disconnect the pneumatic line and high-pressure tubing from the valve.



3. Open the clamp and remove the cutting head assembly, including the on/off valve assembly. Take the assembly to a clean work area for repair.

## Part 02

---

1. Apply a minimum of 5.5 bar (80 psi) shop air to the actuator to open the valve.
2. Put the assembly in a soft-jaw vise, and then remove the gland nut from the valve body. This will separate the on/off valve assembly from the cutting head and expose the poppet seat.
3. An O-ring helps hold the poppet seat in place. Remove the O-ring, and the poppet seat should come out of the valve body. If it doesn't, use the seal installation tool to help loosen the seat.

 O-ring · Poppet seat

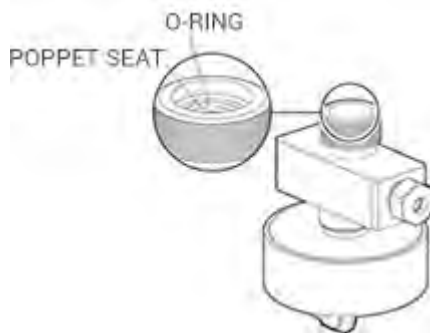

4. Remove the valve body from the actuator, and then set the actuator aside.
5. Place the seal installation tool against the tip of the poppet, and then push the poppet out of the valve body. The bearing, seal, O-ring, and backup ring should also come out with the poppet. If they don't, push these parts out of the valve body in the same direction as you pushed the poppet.

 Poppet · Seal · O-ring · Backup ring

 Bearing

6. Thoroughly clean the valve body, gland nut, and collar with solvent and then dry the parts with shop air.

## Part 03

---

1. Thread the seal guide tool into the valve body.



2. Apply a thin, even layer of WHITE FOOD GRADE GREASE to the poppet, O-ring, seal, and backup ring and then assemble the parts on the seal installation tool as follows:
  - a. Slide the bearing onto the poppet, and then install the backup ring onto the poppet.
  - b. Install the -005 O-ring onto the seal, and then install the seal—O-ring toward the poppet's point—onto the poppet.

▣ The seal assembly should be approximately centered on the length of the poppet.

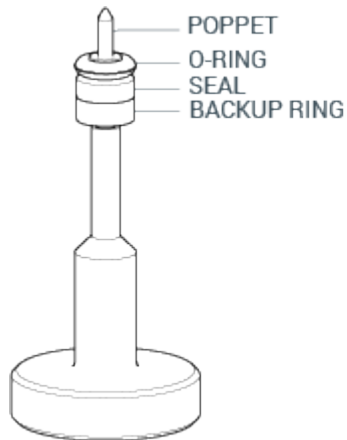

3. Install the poppet/seal assembly—pointed end first—into the actuator end of the valve body. Remove the seal guide tool.

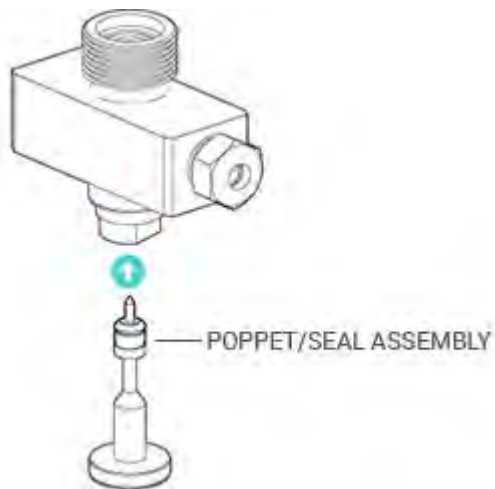

4. Apply a thin, even layer of BLUE LUBRICANT to the actuator threads, and then install the actuator to the valve body.





5. Apply a thin, even layer of BLUE LUBRICANT to the both sides of the poppet seat. Install the poppet seat—such that the small hole faces toward the poppet—into the valve body. Install the -014 O-ring into the groove to hold the poppet seat in place.



6. Apply a thin, even layer of BLUE LUBRICANT to the external threads of the valve body, and then thread it onto the nozzle body by tightening the gland nut. Leave this connection hand tight for now.



## Part 04

---

1. Connect a pneumatic line to the on/off valve assembly, and then turn the air on [5.5 bar (80 psi) minimum] to open the valve.

▣ Open the valve before you tighten the connection to reduce the possibility of galling between the poppet/seat. It also reduces the amount of force required as you are not working against the high spring force of the actuator.

2. Tighten the connection between the nozzle body and the collar to 47–54 N-m (35–40 ft-lb).
3. Turn off the air to close the valve, and then remove the pneumatic line.
4. Install the cutting head assembly on the machine:
  - a. Loosely clamp the cutting head, align the valve with the high-pressure tubing, and then connect the high-pressure tubing.
  - b. Tighten the clamp to secure the cutting head in place.



5. Connect the pneumatic line to the valve, and then turn on the supply air.
6. Start the machine per the appropriate procedure for your machine. When you start the pump, start at low pressure and check for leaks. Then turn the pump to high pressure and check for leaks. When finished, manually actuate the valve a few times to make sure it is operating correctly.

Mach 500 · Mach 300 · Mach 200 ⇒ [Start the machine - \(A\)](#)

Mach 100 ⇒ [Start the machine - \(B\)](#)



SHAPE TECHNOLOGIES GROUP®

## What to do if you get an angle monitor error

---

### Where used

Mach 500 ..... Dynamic XD  
Mach 200 ..... Pivot+ Waterjet

After you select Cycle Start, a series of checks are done by the software to see if the water jet points towards the catcher tank wall or is outside the light curtain boundary. Based on the User Home position and the angles required for the part, it determines how far the water jet travels before it touches the catcher tank wall or goes outside the light curtain boundary. If the water jet violates either condition, cutting cannot occur and the following message is displayed:

This program cannot be executed due to safety reasons. The jet will point towards the wall of the catcher tank, which can potentially damage your machine and cause injury. Try repositioning the part such that the angles are closes to the center of the tank.

If you see this message, you must reposition User Home and the part. To do this, do the following:

1. From the current User Home position, jog the cutting head a few centimeters (inches) away from the catcher tank wall(s) pointed at by the water jet.
2. Set the current position as User Home.
3. Select **Off** for both the **Water** and **Jet** controls, and then select **Cycle Start**.
4. If the message appears, repeat Steps 1–3.
5. If the message does not appear, the part program should begin to load/move. If necessary, stop or end the part program and move the material to the allowed User Home position. Set the **Water** and **Jet** controls to **Auto**, and then cut the part as normal.



SHAPE TECHNOLOGIES GROUP®

## Cut part quality issues

Cutting speed is slower than it should be for a given surface finish and kerf width

Possible cause	Solution
Insufficient abrasive flow	Make sure the abrasive flow rate is set correctly.
Insufficient water pressure	Make sure the pump is providing proper pressure.
Mixing tube standoff is too great	Check standoff; it should be set to 0.10-in.
Different target material properties	Check for consistency of target material.
Abrasive is too fine	Use a coarser grade of abrasive.
Damaged or worn orifice	Check integrity of the waterjet stream. Inspect orifice; replace if needed.

Cutting speed is lower than normal; kerf is too wide

Possible cause	Solution
Mixing tube standoff is too great	Check standoff; it should be set to 0.10-in.
Mixing tube's ID is too large or the mixing tube is worn out	Make sure that the correct size mixing tube is installed. Replace worn mixing tubes.
Damaged or worn orifice	Check for a flaring waterjet stream. Inspect orifice; replace if needed.

### Inconsistent kerf width

Possible cause	Solution
Inconsistent abrasive flow rate	Metering disk may be too large. Change disk and/or reduce cutting speed.
Inconsistent water pressure	Check for steady water pressure; correct any pump problems.
Inconsistent material being cut	Check material.

### Kerf has pronounced "V" shape

Possible cause	Solution
Cutting speed is too fast	Reduce cutting speed.
Mixing tube standoff is too great	Check standoff; it should be set to 0.10-in.
Abrasive flow rate is too low	Increase abrasive flow rate.
Water pressure is too low	Increase water pressure.

### Rough surface finish

Possible cause	Solution
Cutting speed is too fast	Reduce cutting speed.
Mixing tube standoff is too great	Check standoff; it should be set to 0.10-in.
Abrasive is too coarse	Use a finer grade of abrasive.
Damaged or worn orifice	Inspect orifice; replace if needed.



SHAPE TECHNOLOGIES GROUP®

## Tips for cutting different types of materials

---

Tips and general guidelines for cutting certain types of materials.

### All materials

---

The abrasivejet cuts with a water/abrasive mixture. If the cutting speed is relatively fast, the jet will lose power as it penetrates the material. Thus, surface finishes tend to be roughest at the bottom of the cut face.

Surface finish quality decreases as cutting speed increases, and increases as cutting speed decreases, but eventually you will reach a point where a further decrease in cutting speed will not improve surface quality.

Increasing water pressure to increase water velocity (thus abrasivejet power) will improve surface finish.

### Hard or soft materials

---

Taper is a product of the cutting effectiveness. A change in cutting power or cutting speed could drastically alter the taper. If you increase cutting speed for hard materials—such as metal—the taper will also increase. Most hard material tapers are V-shaped—widest at the top of the cut. Some soft materials—such as glass or plastic—may have a reverse taper—wider at the bottom of the cut.

### Laminates

---

Some laminates consist of two or more materials with very different properties. Cutting with the harder material on top might minimize taper.

### Materials with large air gaps

---

Some materials contain an air gap. The jet must cut a layer of material, pass through the gap, then continue cutting. If the gap is less than 0.1 in., the surface finish may be acceptable. With a larger gap, the stream will tend to expand in the open air, generating a 'blowout' on the next layer of material.

Sometimes it is possible to fill the void to decrease the blowout.

When cutting honeycomb parts you may be able to reduce blowout by angling the mixing tube so that the stream does not hit perpendicular to the material surface. This is called raking the cutting head. (Note that blowout cannot always be avoided by using this process).

## Thick materials

---

When cutting thick materials at relatively high speed, the stream exit lags behind the stream entrance (trailback). Corners or small radii cause the lower region of the stream to deflect outward, creating a less accurate cut. To avoid this, slow down at all small radii:

- Manually slow down at corners.
- Set the acceleration/deceleration ramping of the manipulator motion to the appropriate value at the controller. This will change the motion characteristics of the manipulator for every program.
- Change cutting speeds in the part program when necessary. This changes the motion characteristics only for a particular program

## Thin materials

---

To limit exit burr, use a smaller orifice/ nozzle combination at higher pressures and finer abrasive. On some materials it is difficult to completely eliminate exit burr.



SHAPE TECHNOLOGIES GROUP®

## Pivot+ Height Setter

---

### Pivot+ Height Setter

Pages: 9

- **Introduction to Pivot+ Height Setter**  
This article explains what the Pivot+ Height Setter is and how it works with SmartMap.
- **Pivot+ Height Setter specifications**  
Includes air, electrical, environment, operating parameters, and physical specifications for the Pivot+ Height Setter. Also includes spare parts list.
- **Pivot+ Height Setter applications**  
When you should and shouldn't use the Pivot+ Height Setter.
- **Calibrate the Pivot+ Height Setter**  
You must calibrate the Pivot+ Height Setter any time you change the standoff distance. We recommend that you do a calibration daily and every time you change materials or fixture setup. Article gives step-by-step instructions on how to calibrate the Pivot+ Height Setter.
- **Remove and install the Pivot+ Height Setter**  
How to remove and install the Pivot+ Height Setter.
- **Using the SmartMap feature in FlowCUT**  
Overview of SmartMap feature in FlowCUT.
- **Set up the Pivot+ Height Setter in FlowCUT**  
Article outlines how to setup the Pivot+ Height Setter in FlowCUT and provides details on the various settings.
- **Troubleshooting Pivot+ Height Setter by symptom**  
Troubleshoot the Pivot+ Height Setter by issue.
- **Troubleshooting Pivot+ Height Setter by error code**  
Troubleshoot by error code shown in the TouchDown Probe Calibration dialog box.





SHAPE TECHNOLOGIES GROUP®

## Introduction to Pivot+ Height Setter

---



Pivot+ Height Setter with SmartMap™ is a tool for maintaining proper standoff distance while cutting. It consists of a position feedback cylinder attached to the wrist that takes height readings of a material surface. This data is then applied to a tool path to move the cutting head accordingly during the cut.

With the use of SmartMap, the tool creates a contour map of the material prior to cutting. SmartMap overlays an  $X \times Y$  grid on the part and measures the height of the material at the entered number of points. This allows you to run a part program and maintain the desired standoff distance without the use of dynamic contour following or having to find and set the height at each pierce point during a cut. The result? Greater dimensional accuracy maintained over the extent of a part, which is particularly valuable for 3D geometry over large cutting envelopes.



SHAPE TECHNOLOGIES GROUP®

## Pivot+ Height Setter specifications

---

### Air

Air pressure ..... 2 bar (30 psi) minimum  
 Air supply ..... dry and filtered to 10 microns

### Electrical

Power supply ..... 24V to regulator, 10V to device

### Environment

Relative humidity ..... up to 95% @ 49°C (120°F) non-condensing  
 Ambient operating temperature ..... 8–52°C (45–125°F)  
 Airborne dust/contaminants ..... minimal  
 Radio frequency interference ..... minimal

### Operating parameters

Compatibility ..... Mach 200 machines with Pivot+ Waterjet  
 Allowable standoff ..... 2.54–15.24 mm (0.1–0.6 in.)  
 Cutting head tilt ..... 60° from vertical maximum  
 Stroke ..... 38.1 mm (1.5 in.)  
 Material tilt ..... 4° maximum  
 Diameter of collision area during wrist rotation ..... 275 mm (10.8 in.)  
 Scan points enabled ..... 9–200

### Physical

Dimensions ..... 43 × 60 × 212 mm (1.7 × 2.4 × 8.3 in.)  
 Weight ..... 0.68 kg (1.5 lb)

## Other references

### Schematic reference

Electrical schematic for 1313 models ..... 061203-DWG  
 Electrical schematic for 3020, 4020, and 7320 models ..... 060222-DWG  
 Pneumatic schematic ..... 059411-DWG

### Flow parts for Pivot+ Height Setter

Bellows ..... A-14865  
 Cable tie ..... A-14979-1  
 Probe tip ..... 711600-1



## Pivot+ Height Setter applications

---

### When to use the Pivot+ Height Setter

---

Use the Pivot+ Height Setter for the following:

- Large surfaces
- 3D cut geometry
- Gradually changing surface geometry
- Unlevel, but stably mounted material
- Hard and rigid (non-deformable, non-compressible) material

### When not to use the Pivot+ Height Setter

---

We recommend that you do not use the Pivot+ height Setter for the following:

- Soft or flexible (deformable, compressible) material
- Very brittle material
- Material with sharp changes in surface geometry
- Unstably mounted material
- Material liable to stress relieve during cutting
- Cuts that begin off of the material

Although you can use the Pivot+ Height Setter for the following items, it's not necessary.

- Only 2D cut geometry
- Very flat surfaces
- Small surfaces

## Best practices

---

- Inspect material setup for interference with scan and cut path. Note additional collision area created by overhanging touchdown probe.
- Ensure all surfaces are solid and rigid, including catcher tank slats.
- Set the safety height as low as possible to avoid collision and maximize scan cycle time.
- Verify that the chosen grid size creates a contour map that most accurately reflects the part geometry. (Consider the location of scan points relative to dimensions with tightest tolerances.)
- Inspect the bellows regularly for wear and damage.
- Ensure air lines are not obstructed and allow full extension of piston.



SHAPE TECHNOLOGIES GROUP®

## Calibrate the Pivot+ Height Setter

---

You must calibrate the Pivot+ Height Setter any time you change the standoff distance. We recommend that you do a calibration daily and every time you change materials or fixture setup. You don't have to do another calibration if you change material thickness, but you must update the **Thickness** field in the Setup screen to reflect the change.

If an improper calibration occurs—such that the mixing tube would crash—a warning message will display requesting that you recalibrate. There is no warning for a scale factor that leaves the mast too high.

To calibrate the Pivot+ Height Setter, do the following:

1. Open a part file in FlowCUT, and then select **Run Machine**.
2. Go to an arbitrary XY position along the material to be cut. Manually set the Z-axis position at the desired standoff distance with a gauge block.
  - If standoff is anything other than 2.54 mm, (0.100 in.), you must change the value through the Setup screen. Go to **Setup** screen > **Jet Setup** > **Height Sensor** tab. In the **Jet standoff** box, enter the standoff and then set the User Home.
3. On the **Setup** menu, select **Calibrate TDP**.
4. In the **TouchDown Probe Calibration** dialog box, select **Start Calibration** to run the calibration routine.
  - The **Progress** bar is green during the routine and turns to blue when the routine is complete.
5. After calibration is complete, select **Verify Calibration** to reset the Z-home position.
6. Look at the value shown in ( ) in the **Ref. Z Pos (offset)** field. Enter that value in the **Offset** box, and then select **Apply Offset**.
  - Offset is the variable that compensates for the differences in measurement methods during calibration and height finding.

The screenshot shows the 'TouchDown Probe Calibration' window. It features a 'Status' section with a progress bar, an error code field showing '0: No Error. Available to run.', and a 'Reset' button. Below this is the 'Reference Data for Technician' section, which lists various parameters such as TDP Retract EOT, TDP Extend EOT, Scale Factor, and Nominal SF value. A central image of the probe is shown with radio buttons for 'Retract' (selected) and 'Extend'. The 'Parameter Set' section includes an 'Offset (Inch)' field with a value of '0.004' and an 'Apply Offset' button. At the bottom, there are four buttons: 'Start Calibration', 'Stop Process', 'Verify Calibration', and 'Close Window'. A green arrow points from the 'Ref. Z Pos (offset) (in.): -7.306 (0.004)' value to the '0.004' value in the 'Offset (Inch)' field.

Reference Data for Technician	
TDP Retract EOT:	1123
TDP Extend EOT:	23622
Scale Factor:	15044
Nominal SF value:	14204
Calibration Point 1:	15346
Calibration Point 2:	19107
Current Sensor Pos.:	1120
Ref. Z Pos (offset) (in.):	-7.306 (0.004)
Safety Z-Pos (in.):	-7.656

7. Select **Verify Calibration** to confirm that you have returned to the Reference Z-position. Calibration is complete.



## Remove and install the Pivot+ Height Setter

---

### To remove the height setter

---

To remove the height setter, do the following:

1. Turn off the air supply and then disconnect the air hoses and cable.
2. Remove the clamp from height setter bracket, and then remove the bracket from the wrist bracket.
3. Store the device in a location that is protected from water and abrasive.

### To install the height setter

---

To install the height setter, do the following:

1. Attach height setter's bracket to the underside of the wrist bracket—at front mounting holes—with a #5 hex key. Make sure that the cable and air hoses are looped through and secured under the cable clamp before you tighten the last screw.
2. Secure the device to the height setter bracket with the clamp positioned at the top lip of the cylinder using a #5 hex key.
3. Connect the cable, and then connect the EXTEND air hose to the top port and the RETRACT air hose to the bottom port.



## Using the SmartMap feature in FlowCUT

---

Before you use the SmartMap feature in FlowCUT, please review the following:

- **!!!** Standoff distance must be set in the **Setup** screen. Select **Jet Setup**. On the **Height sensor** tab, enter the standoff in the **Jet standoff** box. Do not use the Dynamic waterjet setup dialog. If you do, it could alter the wrist calibration.
- If the SmartMap scan is canceled before completion, Z-home will be automatically reset at safety height of previous scan point.
- Don't set the home position off the material for a touchdown probe-enabled cut or SmartMap scan.

### Run SmartMap

---

Make sure the Pivot+ Plus Height Setter device is calibrated correctly before you run SmartMap.

1. Open a part file in FlowCUT.
2. Go to **Setup > SmartMap settings**, configure the parameters, and then select **Run Machine**.
  - **Grid Size (Row × Column)**  
Enter the number and position of touchdown points for the height scan. There are 9–200 scan points possible; default is 3 × 3.
  - **XY Feedrate**  
Speed moved in X or Y direction between touchdowns.
  - **+Z Feedrate**  
Speed moved in Z direction between touchdowns.
3. Home the machine; the scan begins from User Home.
4. Go to **View > Draw SmartMap path** to overlay the scan path that has been fitted to the part file. Rotate the view and verify that the touchdown points will not interfere with holes, fixtures, or anything else.
5. Run the SmartMap routine:
  - a. Make sure that the material lays stably and that there are no fixtures or other objects in the path of the scan.
  - b. Select the **Enable Height Sensor** check box, and then go to **Cutting > Run SmartMap** to begin the scan.
6. Cutting head will return to XY home at safety height at end of scan. Select **OK** to return to Z home.



7. When scan is complete, general information from scan will be displayed. Select **OK** to exit.

## Viewing options in FlowCUT after a scan

---

There are three viewing options in FlowCUT:

- View > Draw SmartMap path** | Displays touchdown path.
- View > Draw SmartMap measured path** | Displays scan path.
- View > Draw SmartMap** | Displays contour map calculated from scan.

## Cutting with SmartMap

---

1. Do one of the following:
  - Run SmartMap scan.
  - Select **Run Machine**, and then go to **Setup > Use previous SmartMap** to apply previous scan data to current part file.
2. Go to Home position per start of cut.
3. Select the **Enable Height Sensor** check box, and then select **Option Component > Test Height Set to find SOD at current location**. Z-home is set at given position.
4. Clear the **Enable Height Sensor** check box, and then select **Cycle Start**.
5. When you see the "Apply SmartMapping" message, select **Yes** and follow the prompts.

## To do a touchdown probe-enabled cut

---

- Select the **Enable Height Sensor** check box, and then begin the cut.
  - If you see the "Apply SmartMapping" message, select **No**.



SHAPE TECHNOLOGIES GROUP®

## Set up the Pivot+ Height Setter in FlowCUT

---

To set up the device in FlowCUT, do the following:

1. On the **Setup** menu, select **Jet**.
2. In the **Setup** dialog box, select **Height Sensor**.
3. Under **Cutting head movement**, select the setting that best fits your application.
4. Click **Save as Default** or **OK**.

### What settings should I choose?

---

#### Cutting head movement

**Down at jet-on and up at jet-off:** Sets height at each pierce point in a cut and remains at that height until lifting for a rapid traverse or end of the cut.

**Always down:** Sets height at User Home at the beginning of a cut and remains at that height until lifting at the end of the cut.

#### Sensor operation

**Always on during cutting** and **Turn off after setting height** have no functionality for this device.

#### Cutting head lifting options

**Do not lift cutting head if rapid traverse is less than:** Cutting head will not raise safety height (1 in.) between pierce points if rapid traverse is less than specified amount.

**Time for cutting head to reach up position:** Cutting head will dwell for specified number of seconds at top of safety height before proceeding to rapid traverse.

#### Turn off sensor when is speed is over

No functionality for this device.

#### Estimated time for setting height

Determines amount of time for each Height Set routine that is used in calculating overall estimated cut time.



SHAPE TECHNOLOGIES GROUP®

## Troubleshooting Pivot+ Height Setter by symptom

---

### SmartMap data returns all zero values

---

Data gathering is not enabled. In FlowCUT, go to **Advanced > Path-watching setup** and select the **Gather position data** check box.

### Height sensor plunger does not extend or retract

---

- Incorrect air pressure to regulator or incorrect regulator setting
- No power to I/O
- Damaged I/O module

### Sensor is lowered and plunger is compressed, but the Z-axis continues to lift when lifting off the material.

---

Note: Lifting height could be sporadic; in extreme cases the Z-axis will lift to the upper over travel limits.

Plunger is not immediately re-extending from compressed state.

- Air pressure regulator setting is too low.
- Feedback values from the sensor are drifting.

### Mixing tube consistently lowers into the target material

---

- Sensor is not calibrated correctly.
- Mixing tube was not inserted completely.
- The standoff value entered in the FlowCUT setup screen is too small.

## Inconsistent standoff distance

---

- Sensor is not calibrated correctly.
- Feedback values from sensor are drifting. Plunger is not immediately re-extending from compressed state.

## Standoff distance is consistently too high

---

- Standoff value entered in the FlowCUT setup screen is too large.
- Sensor is not calibrated correctly.
- The mixing tube is too short, or the tube was inserted too far (broken mixing chamber).



SHAPE TECHNOLOGIES GROUP®

## Troubleshooting Pivot+ Height Setter by error code

---

Error codes for this device are displayed in the TouchDown Probe Calibration dialog box. If you encounter an error code that is not referenced here or a given solution does not solve the issue, please call Flow Technical Service.

### 1.6 • The second measured value for calibration is abnormal.

Check the air pressure/supply. Make sure the the appropriate pressure is being supplied to the the machine. Check all connections; look for leaks. When you are done with the pneumatic system check, calibrate the device.

### 3.2 • The measured value at the retracted position is out of range.

Check the air pressure/supply. Make sure the the appropriate pressure is being supplied to the the machine. Check all connections; look for leaks. When you are done with the pneumatic system check, calibrate the device.

### 4.0 • Couldn't find the bottom.

Check electrical connections; check the cable that connects the IO Module and the device.

### 4.1 • Fault in test calibration of sensor. Extended value that has less 20000. Is air in?

- Check the air pressure/supply. Make sure the the appropriate pressure is being supplied to the the machine. Check all connections; look for leaks. When you are done with the pneumatic system check, calibrate the device.
- Check electrical connections; check the cable that connects the IO Module and the device.

### 5.1 • The measured value is over the fully extended value.

Check electrical connection integrity as it may have an affect on signal stability. Check connection points for corrosion or build-up which could cause a faulty PPHS feedback signal to the controller.

- Visually inspect connector pins/sockets with a flashlight
- Clean or replace interface cable
- Clean or replace the PPHS device with integral connector

### 7.0 • Failed to run the test HS sub-routine.

- Check the air pressure/supply. Make sure the the appropriate pressure is being supplied to the the machine. Check all connections; look for leaks. When you are done with the pneumatic system check, calibrate the device.
- Check electrical connections; check the cable that connects the IO Module and the device.



SHAPE TECHNOLOGIES GROUP®

## UltraPierce Vacuum Assist

---



### UltraPierce Vacuum Assist

Reference articles in this section for information about UltraPierce Vacuum Assist.

Pages: 7

- **Overview of UltraPierce Vacuum Assist**  
Identifies key components and gives a brief explanation of how UltraPierce works.
- **Set up UltraPierce in FlowCUT**  
How to set up UltraPierce in FlowCut. Also includes information on what settings to choose.
- **Calibrate UltraPierce**  
Learn how to calibrate UltraPierce.
- **Flow Parts for UltraPierce**  
Spares and consumables for UltraPierce.
- **Rotate and replace the exhaust hose**  
How to rotate and replace the UltraPierce exhaust hose.
- **Replace the pinch valve tubing**  
Learn how to replace the UltraPierce pinch valve tubing.
- **Troubleshooting UltraPierce by symptom**  
Troubleshoot UltraPierce by symptom.



SHAPE TECHNOLOGIES GROUP®

## Overview of UltraPierce Vacuum Assist

### Component ID

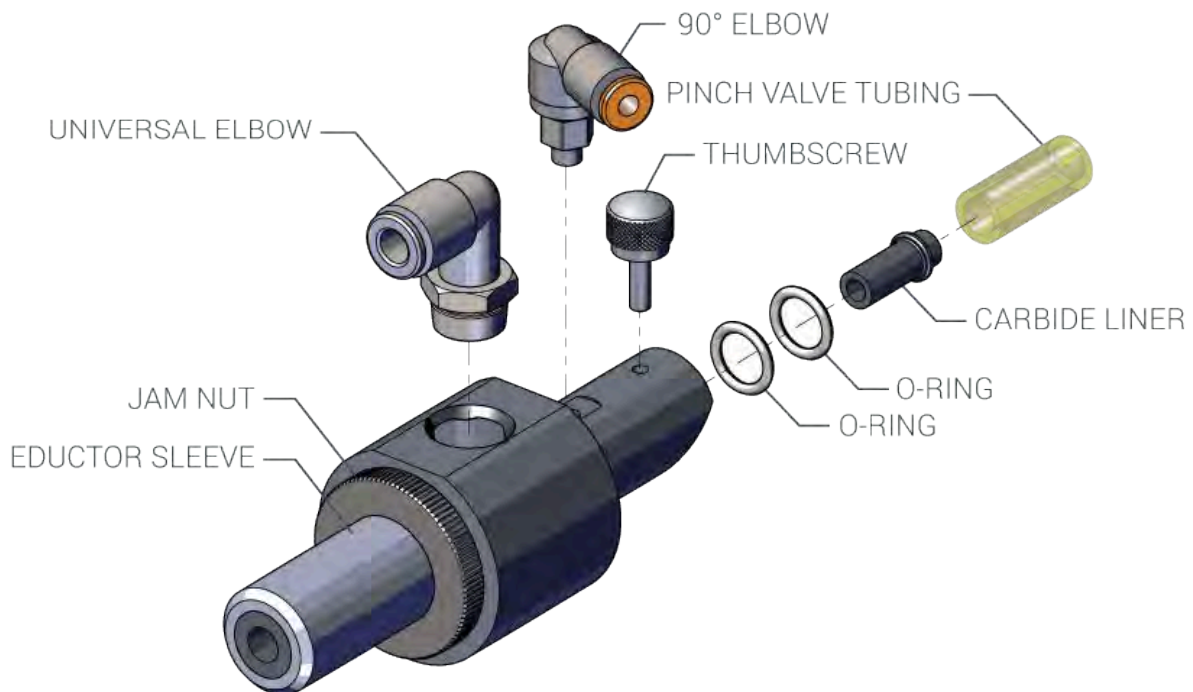

### How it works

UltraPierce Vacuum Assist works on a simple principle—create a vacuum in the cutting head, then use this vacuum to draw abrasive into the mixing chamber before turning on the high-pressure water.

A compressed air-driven eductor supplies the vacuum, and a pinch valve opens and closes the port that connects the educator to the cutting head. The system uses a vacuum to remove the abrasive pulled through the head by the vacuum eductor.

When the vacuum assist is off, there is no air supplied to the eductor. However, air is supplied to the pinch valve in order to close it and isolate the chamber. When the vacuum assist is on, air is supplied to the eductor to generate a vacuum. No air is supplied to the pinch valve, allowing it to remain open.



SHAPE TECHNOLOGIES GROUP®

## Set up UltraPierce in FlowCUT

To set up the device in FlowCut, do the following:

1. Go to **Setup > Jet**. In the dialog box, select **Pierce First**.
2. Under **Pierce** routine, choose a routine.
3. Under **Vacuum** control, choose an option.
4. Under **ON procedure**, enter the time (in seconds) of each dwell, and then select **Abrasive on first, then jet on** to minimize delamination.
5. Under **OFF procedure**, enter the time (in seconds) of each dwell.
6. In the **Pierce time** box, enter the length of time.
7. Select **Save as Default** or **OK**.

Setup

Jet Pierce First | Water Only | Height Sensor

Pierce routine

Hole to hole

Follow the path

Vacuum control

Remain on

Turn on/off every jet cycle

ON procedure

After vacuum on, dwell: 1.0 sec

After abrasive on, dwell: 1.5 sec

After jet on, dwell: 0.5 sec

Abrasive on first, then jet on

OFF procedure

After abrasive off, dwell: 1.5 sec

After jet off, dwell: 3.0 sec

After vacuum off, dwell: 0.1 sec

Pierce time: 20 sec

NOTE: Applies only to piercing all holes first.

Save as Default OK Cancel



## What settings should I choose?

---

### Pierce routine

- To pierce a hole and do a rapid move in the shortest path possible to the next hole, select **Hole to hole**. (Recommended)
- To follow the path as it travels from hole-to-hole, select **Follow the path**. (Recommended only if you have to avoid fixtures.)

### Vacuum control

- To keep the vacuum on throughout the pierce routine, select **Remain on**. (Recommended)
- To turn the vacuum on/off at the end of the jet cycle, select **Turn on/off every jet cycle**. (Not recommended. Pinch valve tubing life and overall reliability of the device will decrease.)

### ON procedure

Recommended starting point for each dwell:

**After vacuum on**

1.5 seconds, and then increase as needed based on the length of the abrasive feed line.

**After abrasive on**

1.5 seconds, and then increase as needed based on the length of the abrasive feed line. Too short of a dwell could damage the material's top surface. Too long of a dwell pulls too much abrasive through the eductor.

**After jet on**

0.5 seconds

### OFF procedure

Recommended starting point for each dwell:

**After abrasive off**

1.5 seconds, and then increase as needed based on the length of the abrasive feed line.

**After jet off**

3 seconds

**After vacuum off**

0.1 seconds

## Pierce time

- Enter the pierce time in seconds. Only use when doing piercing first. This does not affect water or abrasive cutting times.

## Save settings

- To save the settings for the current FlowCut session only, select **OK**. Settings are applied to every file opened until you close FlowCut. The next time you open FlowCut settings revert to the default.
- To save the settings for all future FlowCut sessions, select **Save as default**. Settings are applied to every file opened. However, if a file was saved with a particular setup, that setup is applied to that file.



## Calibrate UltraPierce

---

### Recommended interval

As required; calibrate when the vacuum unit does not produce enough vacuum for correct operation.

### Tools

Vacuum Assist tool kit · 014578-1

To calibrate the device, do the following:

1. Shut down the machine.
2. Disconnect the abrasive line from the abrasive inlet port.
3. Assemble vacuum gauge (including adapter, coupling, and tubing) and then connect it to the open abrasive inlet port.

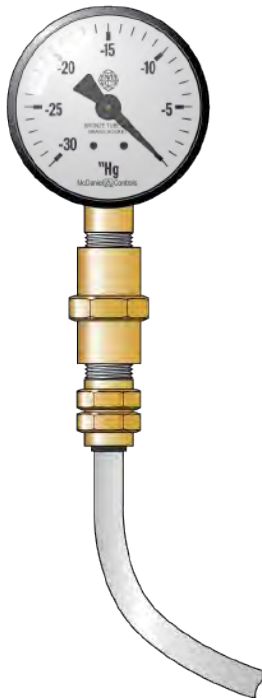

4. Disconnect the exhaust hose from the eductor sleeve.

5. Loosen the jam nut on the eductor sleeve, and then turn the eductor sleeve clockwise until it bottoms out in the vacuum unit.

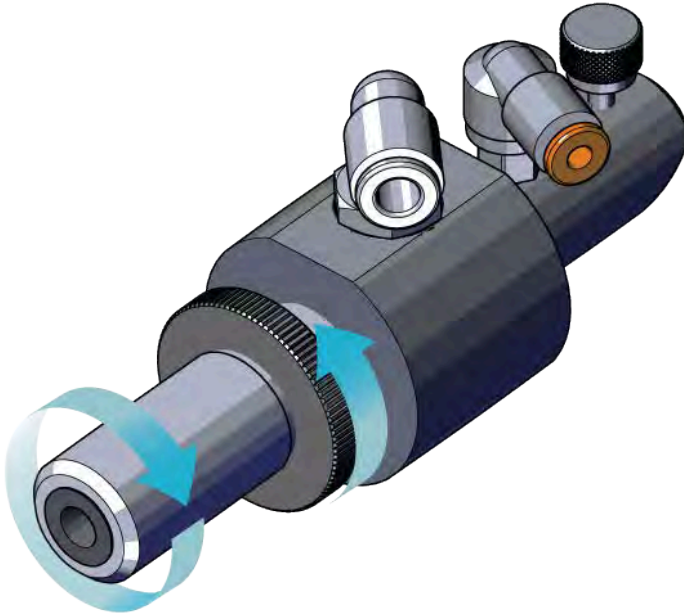

6. Start the vacuum unit and check for leaks. Air will still exit the eductor sleeve, but the vacuum gauge must measure no more than 5 Hg.
7. Slowly turn the eductor sleeve counterclockwise to increase the vacuum level to 10–12 Hg.
  - Some applications may require more than 10–12 Hg. This is acceptable, but higher vacuum levels will shorten the life of the vacuum unit.
8. Tighten the jam nut, and then connect the exhaust hose to the eductor sleeve.
9. Disconnect the vacuum gauge and tubing from the abrasive inlet port.
10. Connect the abrasive line to the abrasive inlet port.



SHAPE TECHNOLOGIES GROUP®

## Flow Parts for UltraPierce

---

### **Eductor hose**

Part # A-18883-3.5

### **Pinch valve tubing**

Part # A-23920-17

### **Vacuum Assist maintenance kit**

Part # 014579-1

Includes carbide liner, O-rings, and pinch valve tubing.



### **Vacuum Assist tool kit**

Part # 014578-1

Includes installation tool and vacuum gauge with tubing and fittings.





## Rotate and replace the exhaust hose

---

### Rotate the exhaust hose

---

#### **Recommended maintenance interval**

Daily

#### **What to do**

Rotate the exhaust hose 45°.

### Replace the exhaust hose

---

#### **Recommended maintenance interval**

As required; replace the exhaust hose when it has worn thin or if there are any holes in it.

#### **Parts**

Tubing (hose) ..... A-18883-3.5

#### **Tools**

Sharp shears or hose cutter

To replace the exhaust hose, do the following:

1. Shut down the machine.
2. Remove the exhaust hose and discard it.
3. Cut a new exhaust hose with a pair of sharp shears or a hose cutter.
4. Connect the exhaust hose to the eductor sleeve.



SHAPE TECHNOLOGIES GROUP®

## Replace the pinch valve tubing

### Recommended maintenance interval

As required; replace the pinch valve tubing when it has worn thin or if there are any holes in it.

### Parts

- Carbide liner ..... 712251-2
- O-ring ..... A-0275-012
- Pinch valve tubing ..... A-23920-17

### Tools

- Needle nose pliers
- Shears
- Vacuum Assist tool kit · 014578-1
  - Installation tool

### Supplies

- White Food Grade Grease

### View 1

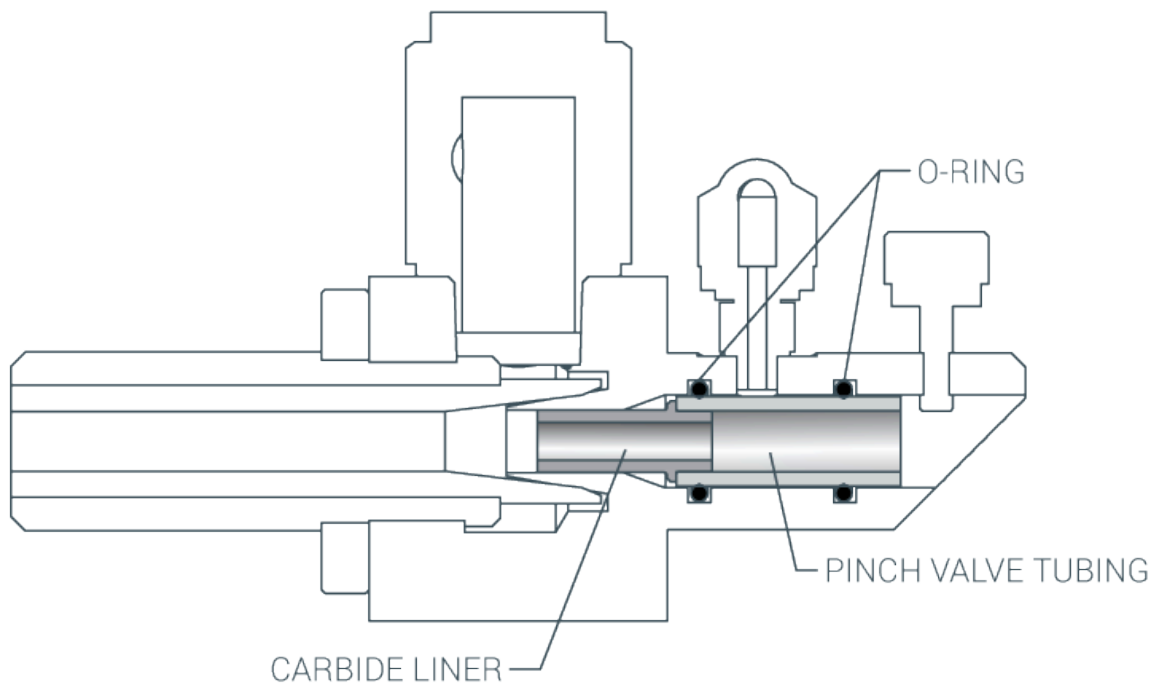

To replace the pinch valve tubing, do the following:

1. Shut down the machine.
2. Loosen the thumbscrew, and then remove the vacuum unit.
3. Pull the pinch valve tubing out of the vacuum unit with needle nose pliers. Discard the pinch valve tubing.
4. Remove the carbide liner from the vacuum unit, and then inspect it. If it is worn or damaged, discard it.
5. Pull the two o-rings out of the vacuum unit. If they are worn or damaged, discard them.
6. Apply a thin, even layer of WHITE FOOD GRADE GREASE to the two O-rings, and then install them into the inside grooves of the vacuum unit.
7. Insert the carbide liner—short end first—into the latex tubing, and then slide the assembly onto the installation tool.
8. When the tubing is flush with the end of the tool, cut the tubing with sharp shears.

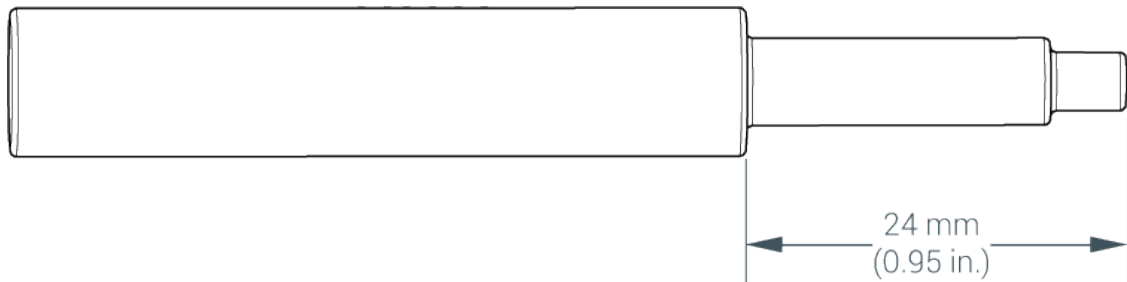

9. Apply a thin, even layer of WHITE FOOD GRADE GREASE on the edge of the tubing that goes into the vacuum unit first, and then install the assembly into the vacuum unit.
10. Install the vacuum unit, and then tighten the thumbscrew.





SHAPE TECHNOLOGIES GROUP®

## Troubleshooting UltraPierce by symptom

---

### Delamination or breakage on the part's top surface

---

Abrasive is not getting to the cutting head before the the water turns on. Increase the **After abrasive on** dwell time.

### Delamination or breakage on the surface around the pierced exit hole

---

Damage at the exit hole is a function of the pressure used to pierce the material—it is not related to vacuum assist operation. Decrease the pierce pressure.

### Clog during normal cutting

---

- UltraPierce is leaking—this causes insufficient vacuum levels in the cutting head, so that it cannot draw abrasive properly. Find the leak and repair it.
- Abrasive feed rate it too high—lower the feed rate.
- Check the pinch valve tubing for holes or tears and replace if needed.

### Clog during piercing

---

- Increase the air pressure to 5.5 bar (80 psi) or greater.
- Check the pinch valve tubing for holes or tears and replace if needed.

### During calibration, vacuum gauge does not read 0–5 Hg.

---

The eductor sleeve has worn out—replace the vacuum pump.

## Pinch valve supply is always on

---

The pinch valve is always getting air—even when the machine is not in operation. If the accessory won't be in use for a long period of time, you can do one of the following:

- Turn the regulator down to zero for the pinch valve
- “Kink” the pinch valve air line and secure it with a cable tie
- Insert a small, two-way valve in the pinch valve line for convenience

## Dynamic XD: interference with the C-motor arm or contact with the material

---

Verify UltraPierce is pointed in the correct direction. If there is damage to the vacuum assist or Dynamic XD wrist, call Flow Service.

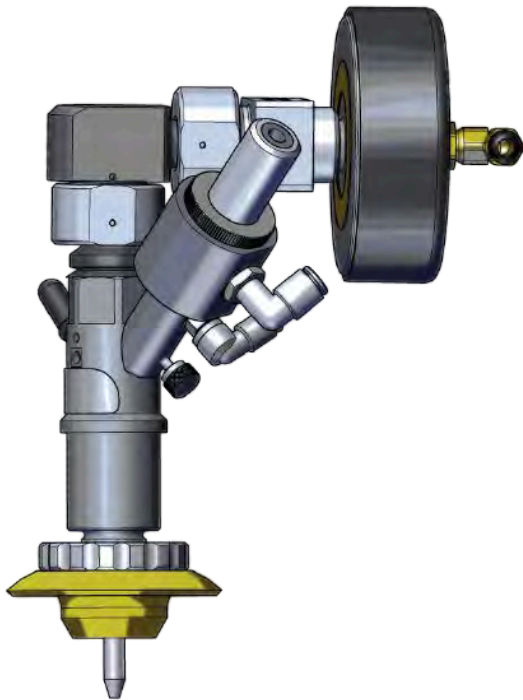

## Dynamic XD: On an XD wrist, the eductor collides with the C arm or tubing

---

Make sure that the vacuum module is in the correct position with respect to the cutting head, and adjust the “clocking” if it is not in the correct position.

The protective cover that is below the C-axis **MUST** be installed at all times for safety.



SHAPE TECHNOLOGIES GROUP®

## Light curtain functionality

---

When one or more beams from the light curtains are interrupted, a stop signal is sent to the controller and the following occurs:

- Part programs stops and error message is displayed
- Axes travel stops
- On/off valve closes
- High-pressure pump is shut off and the high-pressure lines are depressurized

However, if the machine is in Set-up Mode and the light curtain beam is interrupted, an E-stop condition does not occur.



SHAPE TECHNOLOGIES GROUP®

## Abrasive Transfer System (ATS)

---



### **Abrasive Transfer System (ATS)**

Operation and maintenance information for the ATS 2200 and ATS 4400.

Pages: 10

- **ATS specifications**  
Specs for ATS 2200 and ATS 4400.
- **Install the bulk bag**  
To install the ATS bulk bag, follow these steps.
- **Set up the hoses**  
Follow these step-by-step instructions to set up the hoses for the ATS 2200 and ATS 4400.
- **ATS startup**  
Make sure to follow these steps for ATS startup.

- **Extraction**  
To begin extraction from the ATS, follow these steps.
- **Cross-flow separation**  
Follow these steps to operate in Cross-flow mode on the ATS.
- **Bac-Vac separation**  
How to use Back-Vac mode for the ATS 4400. Also includes information on what to do if the pump dead heads during Back-Vac operation.
- **Bag dewatering**  
Follow these steps for bag dewatering for the ATS.
- **Remove the bulk bag**  
To remove the bulk bag from the ATS 2200 or ATS 4400, follow these steps.
- **Cleaning the pump**  
During cross flow separation and dewatering operations, mud flowing through the pump may build up on the internal parts and can harden (particularly if left overnight or weekends). To prevent the buildup of mud from interfering with the operation of the pump, clean the pump.



SHAPE TECHNOLOGIES GROUP®

## ATS specifications

---

### Dimensions (W × H × D)

ATS 2200 ..... 1171 × 1494 × 1538 mm (46 × 59 × 60.5 in.)  
ATS 4400 ..... 1285 × 1597 × 1652 mm (51 × 63 × 65 in.)

### Air requirements

Supply ..... dry and filtered to 10 microns  
Capacity ..... 441 L/min @ 4.1 bar (15.6 scfm @ 60 psi)  
Interface ..... 3/8 in. NPT quick disconnect female socket

### Sandpiper HDF2 diaphragm pump

removes up to 100 lb/min of garnet

### 10-channel radial diffuser

24 in. with rotation stopper

### Hydraulic hand pump

double-acting; opens lid

### Hoses

Dewatering hose ..... 1 in. x 6 ft; with quick release brass cam lock fittings/debris screen  
Discharge hose ..... 1.5 in. x 16 ft; with quick release brass cam lock fittings  
Suction hose ..... 1.5 in. x 16 ft; with quick release brass cam lock fittings  
Garden hose to pump flush out adapter

### Casters

Fixed (2) and Swivel (2)  
Rated to 1100 lb

### Bulk bag with corner straps

10,000 lb burst rating  
91 × 91 × 91 cm (36 × 36 × 36 in.)



## Install the bulk bag

---

### Where used

ATS 2200 and ATS 4400

### New parts used

ATS bulk bag ..... A-32611-1

To install the bulk bag, do the following:

1. Raise the top of the VacBOX:
  - a. Loosen the two door lock pivot bolts, and then rotate both bolts off the door lock tabs.
  - b. Turn the directional control valve on the hand pump clockwise, and then use the hand pump to raise the lid.





2. Insert the bulk bag into the bag frame:
  - a. Offset the corners of the bag from the corners of the bag frame so that the lifting straps do not line up directly on the corners.
  - b. Push down the lifting straps into the channel between the bag cage and the outer wall of the VacBOX, making sure they do not come into direct contact with the rubber seal on the lid. If the lifting straps are trapped between the top of the bag cage and the rubber lid seal, loss of vacuum will occur and machine performance will decrease.
  - c. Spread the bag evenly across the top of the bag support frame to ensure a good seal when the door is closed.
3. Close the VacBOX lid:
  - a. Turn the directional control valve counterclockwise, and then use the hand pump to secure the door.
  - b. Secure the two door lock pivot bolts.

**NOTICE!** Do not overtighten the door lock bolts as damage to the door tabs may result.





SHAPE TECHNOLOGIES GROUP®

## Set up the hoses

---

### Where used

ATS 2200 and ATS 4400

To set up the hoses, do the following:

1. Attach the clear suction line to the inbound side of the cross-flow separator.



2. Attach the clear discharge hose to the outlet manifold of the pump.



3. Attach the hose set to the filter nozzle.





SHAPE TECHNOLOGIES GROUP®

## ATS startup

---

### Where used

ATS 2200 and ATS 4400

For ATS startup, do the following:

1. Check the air supply hose fitting for dirt and/or garnet prior to attaching the air hose to the diaphragm pump.
2. Make sure that all fittings are secure on the top of the VacBOX and are tightened down.
  - Check to ensure that the 2 inch poly dewatering cap is secure.
  - Ensure hydraulic pump is set to the close position and tie rod cylinder is pushing down on the lid (i.e. hydraulic pump handle meets firm resistance when pumped).
  - Snug both lock bolts.
3. Place the suction nozzle assembly into the catcher tank or slurry pit. Make sure that the suction nozzle is below the surface of the water but does not settle into the garnet or mud in the catcher tank. If you do not have enough water in the catcher tank to pre-charge the VacBOX, use a water hose to fill the machine before you begin to remove the garnet.
4. Open the air valve slightly on the supply side of the diaphragm pump. Ideal operating speed is approximately 100–116 strokes per minute. This will give you approximately 50 gpm.  
 You must run the pump on a slow stroke. Periodically, you may have to make slight adjustments to the air regulator to keep the pump operating at the most efficient speed.
5. Once the pump has been activated, air will begin to purge from the machine and bubbles will be visible in the catcher tank or slurry pit. Once the machine is full of water, it is "pre-charged." Air bubbles should no longer be visible and now it is okay to remove the garnet by lowering the nozzle assembly into the heavy sediment.



SHAPE TECHNOLOGIES GROUP®

## Extraction

---

### Where used

ATS 2200 and ATS 4400

The desired vacuum for the holding tank is -8 to -12 hg. on the gauge located on the top of the VacBOX. Any less than this could indicate that the lock bolts should be snugged up more (try  $\frac{1}{4}$  turn on each one and observe the change in vacuum). If low vacuum persists, it could indicate a problem with the diaphragm or a flapper valve in the pump. Vacuum that exceeds -12 hg could indicate a plug in the suction line or debris stuck to the face of the nozzle.

The VacBOX does not need to run continuously. It can be operated only as needed to prevent the accumulation of garnet in the catcher tank.

To begin extraction, do the following:

1. Move the suction nozzle assembly to a place on the catcher tank where it can be pushed down into the garnet to begin the extraction process.
2. Move the nozzle assembly around the tank as often as needed to keep a continuous supply of garnet flowing into the machine.
3. Once the VacBOX holding chamber is full (as checked with a dip stick inserted through the 2 inch dewatering port), proceed with bag dewatering and removal.



SHAPE TECHNOLOGIES GROUP®

## Cross-flow separation

---

### Where used

ATS 2200 and ATS 4400

Cross-flow separation dislodges and removes settled solids from the catcher tank in a closed loop process that does not consume any water. In Cross-flow mode, the pump will operate at approximately 110 strokes per minute which will move 50–60 gallons per minute through the machine. Settled material is pulled through the cross-flow separator and deposited into the bulk bag. Clean water (free of settled material) is returned to the catcher tank through the discharge hose.

To use Cross-flow mode, do the following:

1. Attach shop air hose to the VacBOX pump. Air setting should read between 50-60 psi.
2. Rotate the yellow ball valve handle until it is parallel to the pump suction manifold.

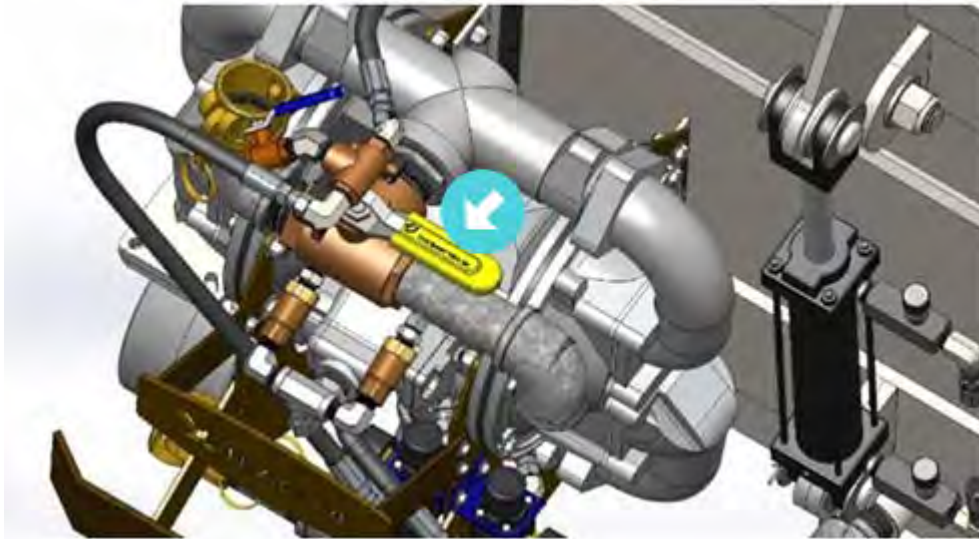



SHAPE TECHNOLOGIES GROUP®

## Bac-Vac separation

---

### Where used

ATS 4400

Back-Vac separation reroutes the flow of water into the suction end of the pump. In Back-Vac mode, water is pulled from around the outside of the bulk bag instead of pulling from the top of the cross-flow separator as it does in Cross-flow mode. This creates a vacuum outside of the bag, which pulls water through the bag membrane. Silt and fines are left in the bulk bag and clean water is returned to the catcher tank.

To use Back-Vac mode, do the following:

- Rotate the ball valve handle until it is perpendicular to the pump suction manifold.

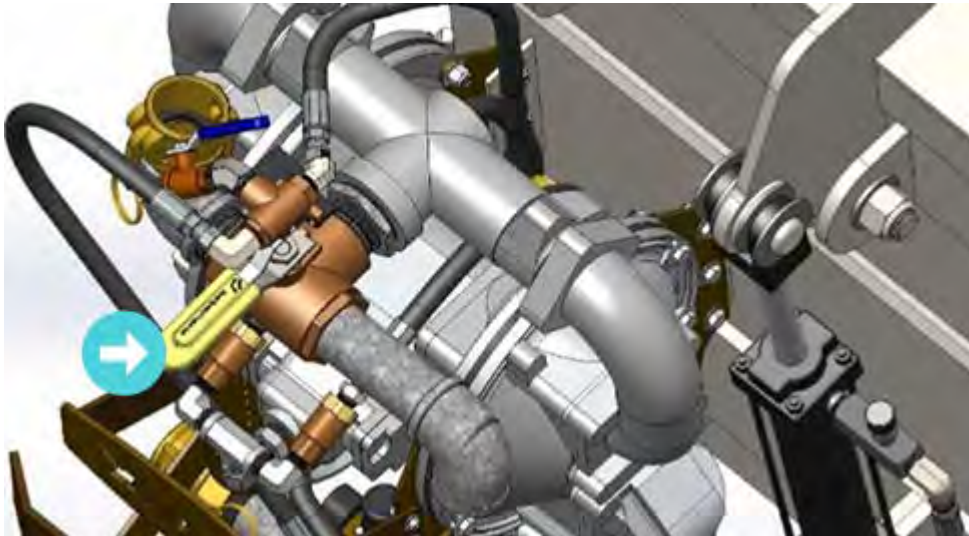

## What to do if the pump dead heads during Back-Vac operation

---

During the Back-Vac separation process, vacuum can start to build outside the bag due to a buildup of removed solids on the sides of the bulk bag. The pump is designed to dead head at a vacuum between -15 and -20 hg. If the pump dead heads during Back-Vac operation, follow the steps below:

1. Lift the suction nozzle assembly out of the water, but make sure to keep it over the catcher tank to catch any discharge water.
2. Turn the ball valve handle to Cross-flow mode for 30 seconds to start the pump and drain water from the cross-flow separator into the catcher tank.
3. Turn off the supply air valve.
4. Bleed any remaining vacuum from the holding chamber by loosening the two-inch poly-cap and lifting slowly. Replace the cap once vacuum has been released.
5. Raise the VacBOX lid and examine the bulk bag—silt cakes should have fallen down into the bag when vacuum was released. However, you may have to scrape the sides of the bag to knock the silt cakes loose before you close the lid and resume Back-Vac operation.







## Bag dewatering

---

### Bag dewatering for the ATS 2200

---

Bag dewatering reroutes the flow of water into the suction end of the pump. Water is pulled from around the outside of the bulk bag instead of pulling from the top of the cross-flow separator as it does in Cross-flow mode. This creates a vacuum outside of the bag, which pulls water through the bag membrane. Water is also removed from the void between the bag frame and the outer chamber wall, and clean water is returned to the catcher tank.

For ATS 2200 bag dewatering , do the following:

1. While the machine is in operation, remove the suction and discharge hoses from below the water level, but leave them over the catcher tank to remove any excess water from the cross-flow separator. After several seconds, the discharge hose will stop discharging water. Once this occurs, it's okay to raise the lid on the VacBOX to continue manual dewatering.
2. Purge excess water from the machine before you remove the bulk bag. To remove the water and silt surrounding the bag, rotate the ball valve handle until it is perpendicular to the pump suction manifold, and then restart the machine.
  - Lid can be in either the open or closed position for this step.



3. Remove the water from the top of the bag:
  - a. Disconnect the suction hose from the top of the pump and connect the 1" X 6' dewatering hose into the CAM fitting on the pump inlet.
  - b. Turn on the air supply to the pump, and then use the dewatering hose to vacuum the remaining water from the top of the bulk bag and remove excess water and silt from the channel between the bag cage and outer chamber of the machine.

## Bag dewatering for the ATS 4400

---

For ATS 4400 bag dewatering, do the following:

1. While the machine is in operation, remove the suction and discharge hoses from below the water level, but leave them over the catcher tank to remove excess water from the cross-flow separator. After several seconds, the discharge hose will stop discharging water. Once this occurs, it's okay to raise the lid on the VacBOX to continue manual dewatering.
2. Remove the water from the top of the bag:
  - a. Disconnect the suction hose from the top of the pump and connect the 1" X 6' dewatering hose into the CAM fitting on the pump inlet.
  - b. Turn on the air supply to the pump and use the dewatering hose to vacuum the remaining water from the top of the bulk bag.



SHAPE TECHNOLOGIES GROUP®

## Remove the bulk bag

---

### Where used

ATS 2200 and ATS 4400

To remove the bulk bag from the VacBOX, do the following:

1. Expose the lifting straps from all four corners.



2. Connect the four straps to lifting equipment—such as a forklift—and lift the bulk bag from the VacBOX chamber.



**CAUTION!** Ensure the straps are protected from any sharp edges on the lifting device to avoid cutting the straps and dropping the load. Immediately transfer a fully loaded bulk bag to a pallet for safe transportation to storage/disposal area. If you are using a forklift, carefully approach from the side to avoid damage to the VacBOX lid and/or seals.

3. Use a garden hose to rinse all garnet/mud from the bottom of the machine (under the floor of the bag).

4. Use the applicable setting—based on model—to pump the residual mud out of the VacBOX and back into the catcher tank or slurry pit.

ATS 2200 ..... Bag Dewatering setting

ATS 4400 ..... Back-Vac setting

■ Mud build up on the bottom of the cage will interfere with operating the machine in Bag Dewatering or Back-Vac mode. Ensure the inside is rinsed clean with every bag change.



SHAPE TECHNOLOGIES GROUP®

## Cleaning the pump

### Where used

ATS 2200 and ATS 4400

During cross flow separation and dewatering operations, mud flowing through the pump may build up on the internal parts and can harden (particularly if left overnight or weekends). To prevent the buildup of mud from interfering with the operation of the pump, use the supplied hose rinse adapter to connect a standard garden hose to the CAM lock inlet (top) of the pump. Performing the steps below will ensure trouble free operation of your pump for many years.



To clean the pump, do the following:

1. Connect a garden hose to the pump rinse adapter.
2. Disconnect the cross-flow separator (or the dewatering) hose from the top of the pump.
3. Connect the pump rinse adapter to the inlet of the pump, and then turn on the water to the hose.
  - Make sure the suction/discharge nozzle is placed in the catcher tank as the water discharged from the pump will flow out the end of the discharge line (along with any material being flushed from the pump)
4. Run the hose until clear water flows from the discharge hose into the catcher tank.
  - Turn on the air supply valve enough to cycle the pump a few times to ensure a complete flush.
5. Turn off the water and reconnect the cross-flow separator hose to the pump inlet.



## Final Filter System

---

The Final Filter System is designed to reduce the level of spent garnet and swarf in the overflow water stream to a level that can be safely discharged into sewers or septic systems. The system consists of the following components:

- three stepped weir tanks
- two 50 micron filters
- a sump pump
- a steel frame

The overflow water from the catcher tank flows through the weir tanks, then is pumped through the filters. As the water passes through the tanks, the larger particles settle out. Any suspended particles larger than 50 microns are trapped by the filters. Operation of the Final Filter System is automatic. Make sure power is supplied to the sump pump.

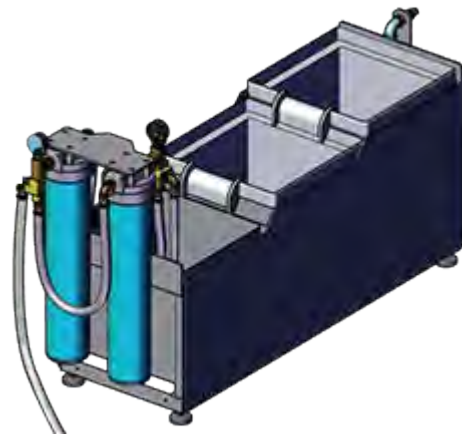

### Specification

Capacity ..... 53 L/min (14 gpm)  
Interface type ..... ½ in. JIC

## Empty the tanks

---

How often to empty the weir tanks depends on the nature and amount of cutting being performed, but we recommend that you empty them when the level of solids in the tanks reaches half full.

To empty the tanks, do the following:

1. Adjust the overflow to stop the flow of water into the final filter.
2. Transfer the water remaining in the weir tanks to the third tank, where it can be removed by the sump pump.
3. Remove the tanks from the frame and dump out the accumulated solids.
4. Replace the tanks in the frame

## Replace the filter elements

---

Replace the 50 micron filter elements (Part #A-00750-6) when the pressure drop across the filters exceeds 5 psig. To determine the pressure drop, subtract the pressure reading obtained from the gauge on the outlet side of the filters from the reading obtained from the inlet side of the filters. **Readings must be taken while the pump is operating.**



SHAPE TECHNOLOGIES GROUP®

## 100 lb hopper

---

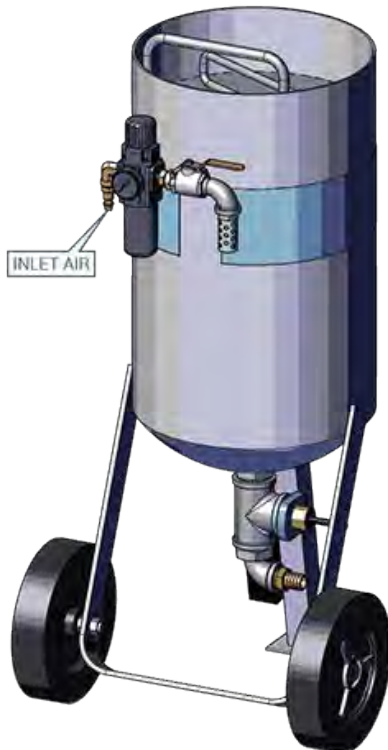

### Specification

---

**Air supply**

dry and filtered to 10 microns

**Capacity**

56.6 L/min @ 6.2 bar (2 scfm @ 90 psi)

283.2 L/min @ 6.2 bar (10 scfm @ 90 psi) initial fill

**Interface**

$\frac{3}{4}$  in. NPT





SHAPE TECHNOLOGIES GROUP®

## 2200 lb hopper

---

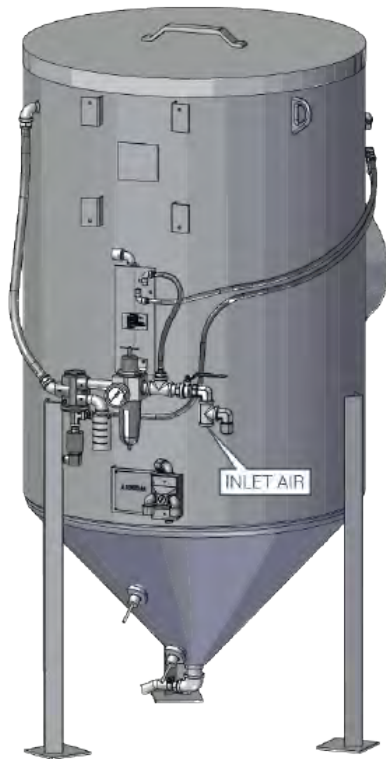

### Specification

---

**Air supply**

dry and filtered to 10 microns

**Capacity**

56.6 L/min @ 6.2 bar (2 scfm @ 90 psi)  
283.2 L/min @ 6.2 bar (10 scfm @ 90 psi) initial fill

**Interface**

3/4 in. NPT



SHAPE TECHNOLOGIES GROUP®

## PASER CF900 Abrasive Delivery System

---

### **PASER CF900 Abrasive Delivery System**

Operation, maintenance, and troubleshooting for the CF900 hopper.

Pages: 10

- **Component ID for CF900 hopper**  
Identifies components of the CF900.
- **Specifications - CF900 hopper**  
Specs—including operating parameters—for the CF900 ADS.
- **Using the display panel during operation**  
Overview of the CF900's display panel functionality and operation.
- **Understand the warning indicators/audible signal**  
During operation, the yellow warning indicator and the audio signal identify specific conditions pertinent to operation. Learn what to do when you see and/or hear communications from the warning indicator and audible signal.
- **Recommended pressure settings for CF900 pressure regulators**  
Recommended pressure settings for CF900 pressure regulators, including schematic.
- **Fill, start, or shut down the hopper**  
How to fill, start, stop, or shut down the ADS.
- **Preventative maintenance schedule for CF900 hopper**  
PM schedule for the CF900 hopper.
- **Replace the PV1 pinch valve seal**  
Replace the CF900 hopper's PV1 pinch valve seal after approximately 6000 switching cycles. This article gives step-by-step instructions on how to replace it.
- **Troubleshooting the hopper with FlowSENSE**  
Troubleshooting the hopper using FlowSENSE.
- **Troubleshoot the CF900 hopper by symptom**  
Basic troubleshooting for the CF900 hopper.



SHAPE TECHNOLOGIES GROUP®

## Component ID for CF900 hopper

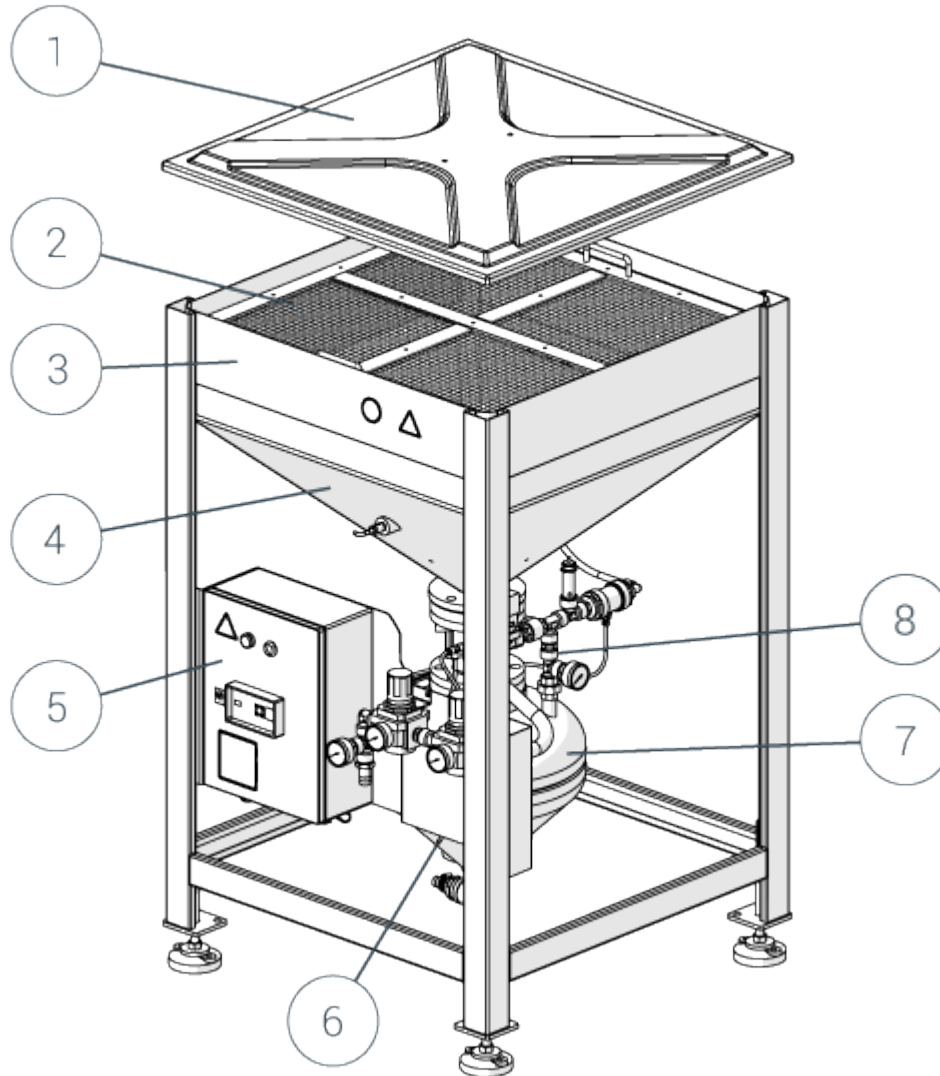

- 1 Lid**  
The lid prevents abrasive from spraying from the silo when the vessel releases pressure before entering the fill cycle.
- 2 Sieve**  
When you fill the ADS with abrasive, it goes through the sieve to its temporary storage place—the silo.

**3 Silo**

Temporary storage place for abrasive. You can fill the silo without stopping the ADS. During a vessel fill cycle, abrasive moves from the silo through a pinch valve, and then into the vessel.

**4 Silo low-abrasive switch**

If this switch does not sense abrasive, the yellow warning indicator flashes continuously and the audible signal sounds in a rhythmic pattern. Also, the display panel shows the *Silo Empty* notice.

**5 Control panel**

The control cabinet contains the PLC, which monitors operating conditions and sends control signals to the solenoid valves, the yellow warning indicator, and the audible signal.

**6 Vessel low-abrasive switch**

If this switch does not sense abrasive for 20 seconds, the yellow warning indicator illuminates continuously and the audible signal sounds continuously. Also, the display panel shows the Vessel Empty notice. In FlowCUT, the part program stops and a message is displayed.

**7 Vessel**

After a vessel fill cycle, the vessel is pressurized and pushes the abrasive through a hose to the machine's abrasive metering valve.

**8 Pinch valve pneumatic**

## Control cabinet

---

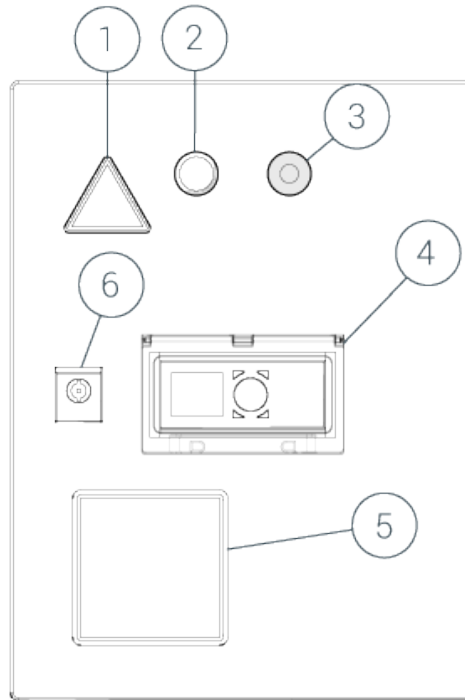

- 1 Electrical hazard warning label**  
 Indicates there is a risk of electrical shock.
- 2 Yellow warning indicator**  
 Identifies specific conditions pertinent to operation. See *Understand the warning indicators/audible signal* article.
- 3 Audible signal**  
 Identifies specific conditions pertinent to operation. See *Understand the warning indicators/audible signal* article.
- 4 Display panel**  
 See *Using the display panel during operation* article.
- 5 CE label**
- 6 Panel lock**  
 The PLC and terminal strip are located behind the panel lock. Keep this panel closed and locked at all times.
- 7 Power switch (not shown)**  
 When the power switch is disengaged, no pressure is supplied to the vessel and PV1 stays closed.

## Pneumatics

---

Pneumatic controls include:

- Two pinch valves (PV1 & PV2)
- Two pressure regulating valves (PR1 & PR2)
- Two N/C solenoid valves (SOL311 & SOL319)
- One N/O solenoid valve for venting (SOL351)
- Two check valves (CV1 & CV2)

The pinch valve pressure controls the pinch valve. The conveying pressure controls the vessel. A safety valve opens at 7 bar (102 psi) and limits the maximum pressure in the vessel.

PV1 is operated by compressed air and controlled by SOL351.

Proximity switch PS219 (inside vessel) sends a signal to the PLC to indicate presence of abrasive. If there is no abrasive, the PLC sends a signal to release the pressure from the vessel, and then sends a signal to open the pinch valve. When the proximity switch senses abrasive during refilling, a delay timer starts. When the delay timer ends, the pinch valve closes, and the vessel pressurizes.

When SOL319 opens pinch valve PV2, pressure is released from the vessel.



SHAPE TECHNOLOGIES GROUP®

## Specifications · CF900 hopper

---

### Operating parameters

Abrasive capacity .....	425 kg (937 lb)
Abrasive compatibility .....	50–120 mesh
Air pressure/volume .....	6.9–8.3 bar @ 566 L/min (100–120 psi @ 20 scfm)
Required pressure difference between PR1 & PR2 .....	3.45 bar (50 psi)

### Physical

Dimensions (H × W × D) .....	1420 × 850 × 850 mm (56 × 33.5 × 33.5 in.)
Approximate weight empty .....	112 kg (247 lb)
Approximate weight full .....	537 kg (1184 lb)
Abrasive capacity .....	425 kg (937 lb)
Recommended clearance on each side .....	1000 mm (39 in.)

### Electrical

Supply voltage .....	100–240 VAC, 50/60 Hz or 24VDC2
AC frequency .....	50/60 Hz
Full-load current	
100 VAC .....	0.48 A
240 VAC .....	0.20 A
24 VDC .....	2.0 A
Largest- load current .....	2.0 A
Short-circuit current rating (SCCR) .....	2.5 kA

### Environment requirements

Ambient temperature .....	0°–55°C (32°–131°F)
Relative humidity .....	5–95%
Elevation .....	0–2500 m (0–8200 ft) above sea level

### Air requirements

Air supply .....	dry and filtered to 10 microns
Air pressure/volume .....	6.9–8.3 bar @ 566 L/min (100–120 psi @ 20 scfm)
Air line size .....	≥ 20 mm (¾ in.)
Interface type .....	¾ in. NPT
Required connections .....	one



SHAPE TECHNOLOGIES GROUP®



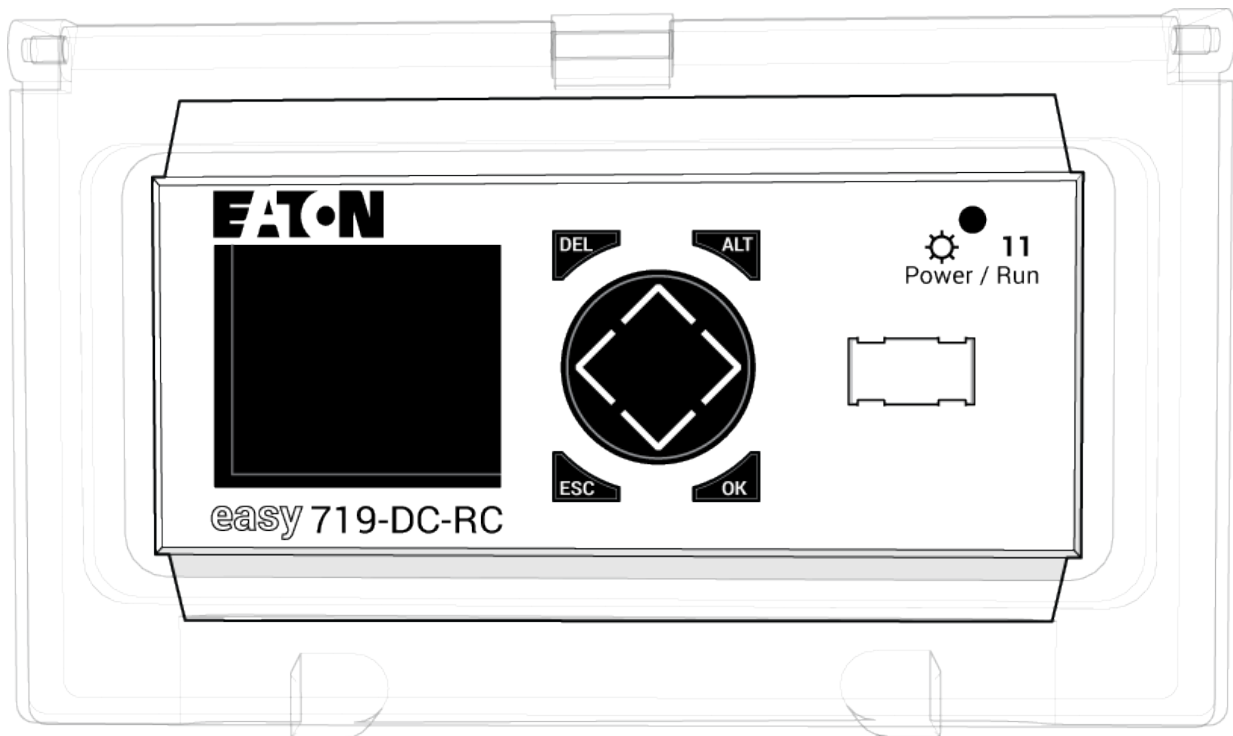

## Using the display panel during operation

---





## Display panel buttons

Button	To	Do this
	View the software version, operating hours (h), and switching cycles (c).	Press and hold the <b>P1</b> button for five seconds.
	Release pressure from the vessel.	Press the <b>P2</b> button.
	Set the cycle counter to zero.	Press and hold the <b>P3</b> button for five seconds.
	Switch the potential free contacts for a warning message from N/O to N/C. You can accept the selected signal in the ADS and use it there for an additional alarm or as a way to stop the cutting process.	Press and hold the <b>P4</b> button for 10 seconds.
<b>ALT</b>	No functionality.	—
<b>DEL</b>	No functionality.	—
<b>ESC</b>	No functionality.	—
<b>OK</b>	Functional from the "Running" screen only.	<p><b>Password:</b> Functionality disabled.</p> <p><b>Stop/Run:</b> A check mark show what state the unit is in. Press the OK button to toggle between states. When you switch from Run=&gt;Stop, the pressure vessel depressurizes.</p> <p><b>Password:</b> Appears twice in menu, but functionality is disabled.</p> <p><b>Info:</b> Displays information about the PLC from the manufacturer.</p> <p><b>Set clock:</b> Sets the correct time and date for the PLC; however, this is unnecessary for operation as the unit counts relative time from a "zero" point.</p>

## Display panel notices

---

The display panel's screen shows the following notices:

Notice	What does it mean?
Filling	Fill cycle.
Bleed	Release of the pressure vessel.
Running	ADS is conveying abrasive.
Silo Empty	Silo is empty.
Vessel Empty.	Vessel is empty.
Replace Insert of Pinch Valve Reset P3 =>	Displays after 6000 cycles. When you see this notice, it's time to replace the PV1 pinch valve seal.



SHAPE TECHNOLOGIES GROUP®

## Understand the warning indicators/audible signal

During operation, the yellow warning indicator and the audio signal on the control cabinet identify specific conditions pertinent to operation.

If this happens...	Do this
Yellow warning indicator flashes continuously + audible signal sounds in a rhythmic pattern.	Fill the silo with abrasive—you have reached the minimum level of abrasive required for operation. Recover from the error in FlowCUT/FlowSENSE.
Yellow warning indicator illuminates continuously + audible signal sounds continuously.	Fill the silo with abrasive—you are out of abrasive and the ADS will remain stopped until filled. Recover from the error in FlowCUT/FlowSENSE.



## Recommended pressure settings for CF900 pressure regulators

To ensure the pinch valve closes all the way and to help prevent early pinch valve failure, make sure you use the following settings:

- PR1 pressure ..... 4.83–6.21 bar (70–90 psi)
- PR2 pressure ..... 1.38–2.76 bar (20–40 psi)
- Required pressure differential between PR1 & PR2 ..... 3.45 bar (50 psi)

Initially, set PR1 to 5.5 bar (80 psi) and PR2 to 2 bar (30 psi). Next, adjust the pressure for PR2 since this is what pushes abrasive to the metering valve. Pressure may be ok at 2 bar (30 psi), but if you have to make adjustments, keep it between 1.39–2.76 bar (20–40 psi). After you've established the correct pressure for PR2, adjust PR1 to 3.45 bar (50 psi) more than PR2. This ensures the pressure differential of 3.45 bar (50 psi) is maintained.

### Schematic

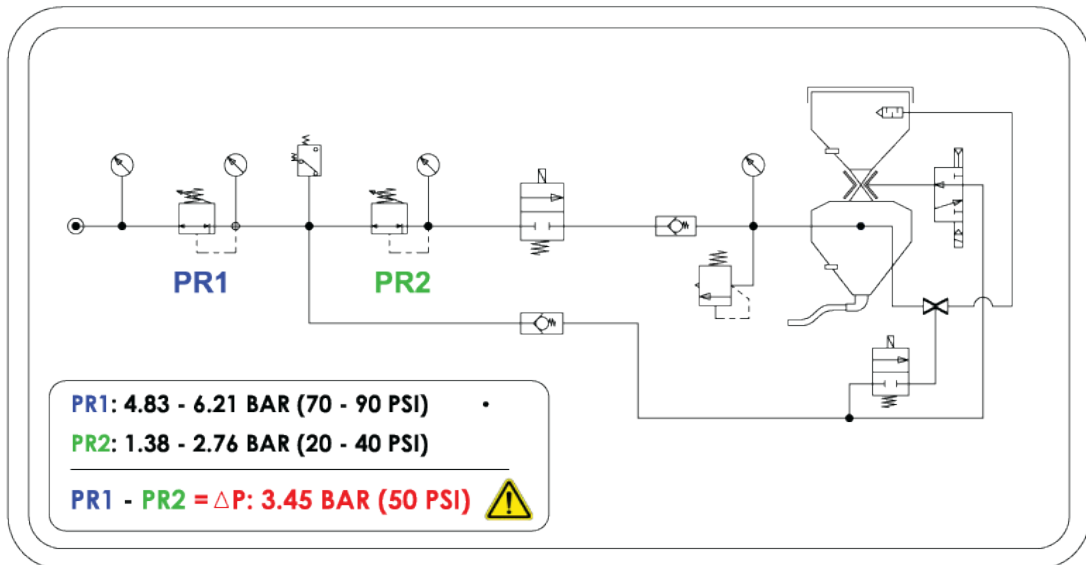



## Fill, start, or shut down the hopper

---

### To fill the hopper

---

Remove the lid, fill the silo with abrasive, and then put the lid on.

 **CAUTION!**

- Wear safety goggles to prevent eye injuries caused by pressurized abrasive leaking from the silo.
- Wear a dust mask or respirator to reduce particle or dust inhalation when you fill the hopper with abrasive.
- Observe proper lifting techniques when lifting abrasive bags.
- Avoid adding abrasive near the pressure valve muffler.

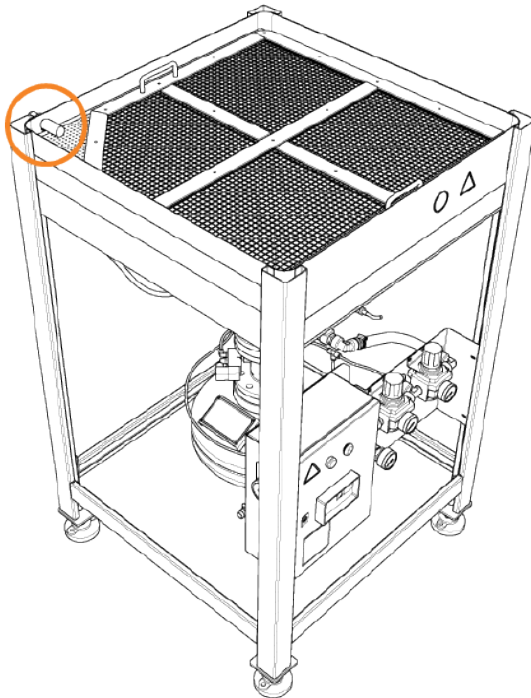

## Hopper startup

---

Supply air to the hopper must always be present prior to applying electrical power to the hopper. Electrical power must always be cycled/applied **after** supply air has been removed and reapplied to the hopper. This allows for proper cycling/sequencing of solenoid valves, regardless of which pinch valve housing or PLC code is onboard the hopper.

If you did this...	Do this for startup
Shut off supply air to the hopper, but left the hopper powered on	Apply supply air to the hopper first, and then cycle power to the hopper (off, then on again).
Turned off power to the hopper, but left the supply air on	Power on the hopper.
Shut off both supply air and power to the hopper	Apply supply air to the hopper first, and then power on the hopper.

## To shut down the hopper

---

Shut down the machine, and then turn off the power switch to the hopper.



SHAPE TECHNOLOGIES GROUP®

## Preventative maintenance schedule for CF900 hopper

Preventative maintenance schedule for the Paser CF900 Abrasive Delivery System.

What do I do?	When do I do it?
Examine the pressure regulating valves and solenoid valves for damage.	Daily
Examine the solenoid valve on the pinch valve for damage.	Daily
Examine the pressure gauges for functionality.	Daily
Ensure the pressure difference between PR1 and PR2 is at least 3.45 bar (50 psi).	Daily
Replace the PV1 pinch valve seal.	Every 6000 cycles



SHAPE TECHNOLOGIES GROUP®

## Replace the PV1 pinch valve seal

---

### Recommended maintenance interval

Replace the PV1 pinch valve seal after approximately 6000 switching cycles.

### Parts

Pinch valve seal (hose insert) ..... A-31850-1

### Tools

- Adjustable wrenches: 6 in. & 12 in.

### Supplies

- Clean, lint-free rag
- Wooden blocking

### Notes



= Assistant required for this step.

### Safety precaution

The vessel could weigh up to 91 kg (200 lb) when full. Support the vessel if it is not empty.



## Remove the PV1 pinch valve

---

1. Empty the abrasive from the silo and, if possible, from the vessel.
2. Record the pressure settings for PR1 and PR2, and then set PR1 0 bar (0 psi).
3. Do the Lockout/Tagout procedure.
4. Disconnect all abrasive and air hoses from the vessel, pinch valve, and pneumatic controls.
5. Disconnect the cables from the manifold pressure sensors.



- ★ Label the cables so that it is easier to connect the cables later!
6. Loosen the hose clamp, and then disconnect the hose.

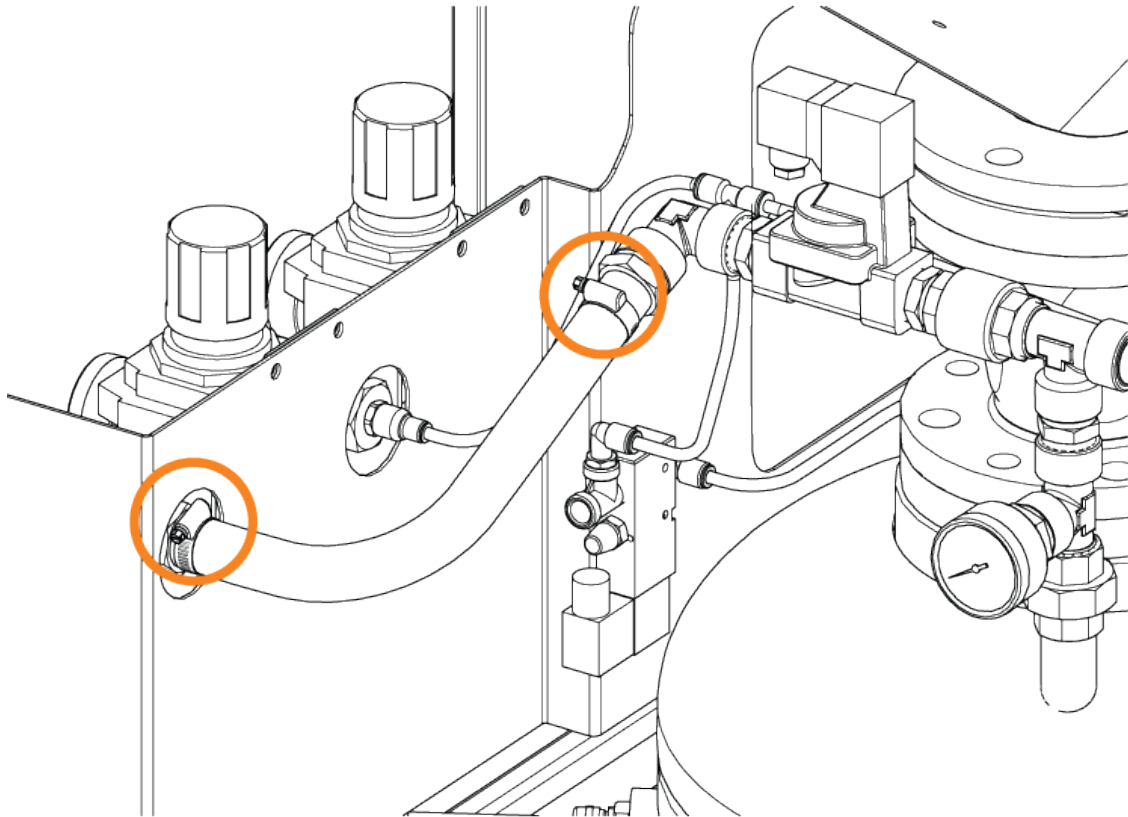

7. Loosen the coupling that attaches the pneumatic manifold to the vessel, and then set the manifold aside.

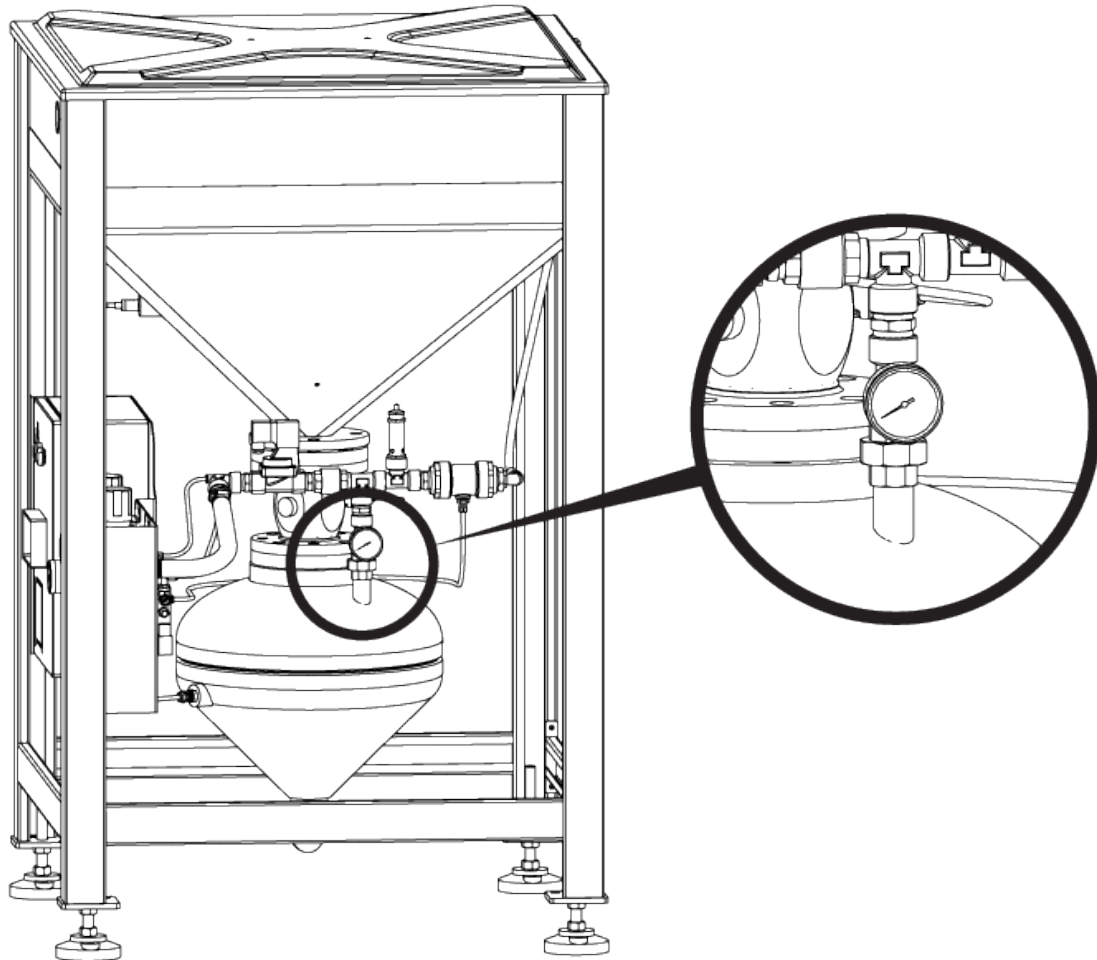

8. Disconnect the cable from the solenoid mounted on the pinch valve.
9. Position wooden blocking between the floor and the abrasive outlet port to support the vessel during removal.
10.  Remove the four M16 hex screws, and then lower the vessel onto the wooden blocking.

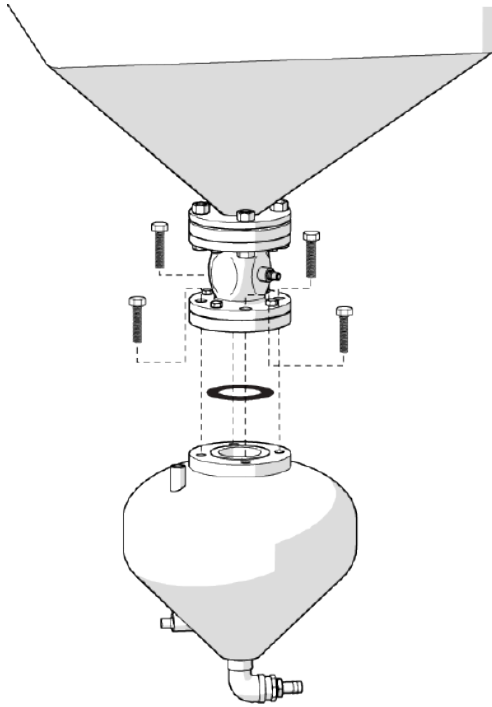

11. Move the vessel and the wooden blocking away from the pinch valve.
12. Remove the gasket from between the vessel and the pinch valve housing. Clean the gasket with a lint-free rag, and then set it aside.
13. Remove the M16 hex screws and nuts, and then remove the pinch valve.

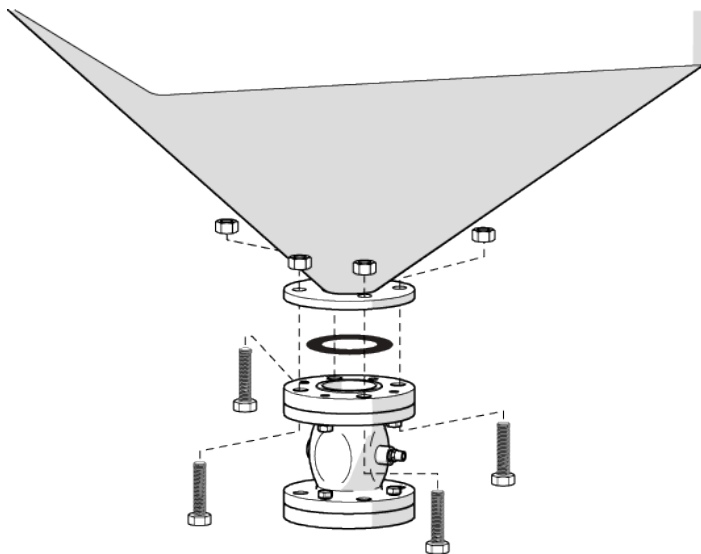

14. Remove the gasket. Clean the gasket with a lint-free rag, and then set the gasket aside.

## Replace the PV1 pinch valve seal

1. Remove the eight M12 screws and nuts, and then remove the two flanges from the pinch valve housing.

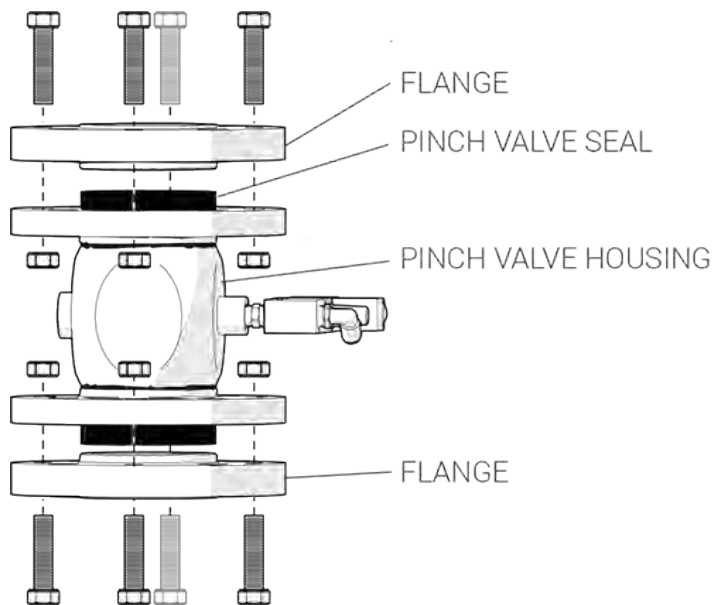

2. Pull the pinch valve seal out of the pinch valve housing.
3. Examine the tapered surfaces on the pinch valve flanges and housing. Tapered surfaces should be smooth (paint discoloration is okay) with no grooves or pitting. Replace the pinch valve flange if the tapered surfaces have damage. Replace the pinch valve if needed.

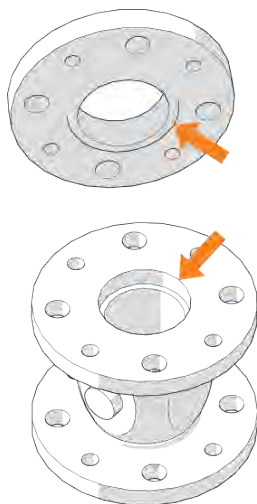

4. Clean the tapered surfaces with a lint-free rag. The surfaces must be clean before installing the new pinch valve seal.

5. Push the pinch valve seal into the pinch valve housing. Adjust the pinch valve seal so that both ends extend equally from the pinch valve housing.

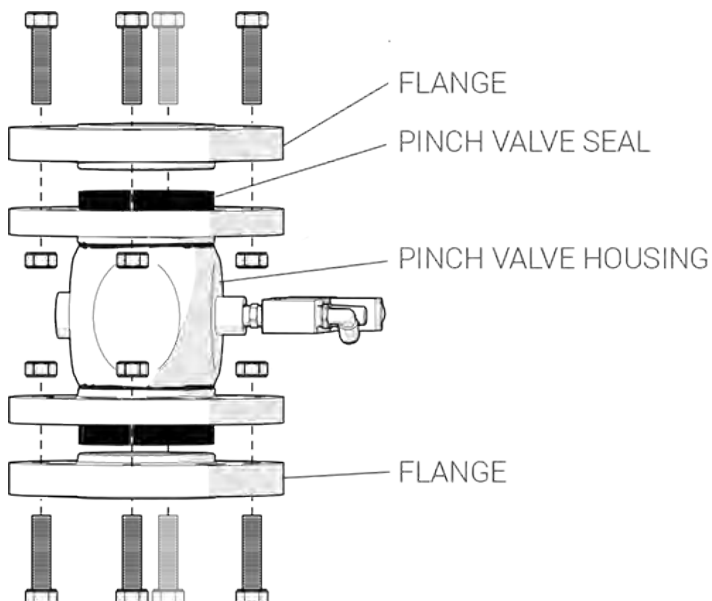

6. For each flange, apply a small amount of tension to the flanges with two opposing M12 screws and nuts. Guide the tapered surfaces of the flanges to the interior of the pinch valve seal. Do not allow the pinch valve seal to twist during tensioning.

■ If the screws cannot engage the flange threads, use M12 70 mm screws to seat the flanges until the stock flange bolts are engaged.

7. Loosely install the remaining M12 screws and nuts. Evenly tighten them in a circular pattern until they are tight. The gap between the tapered flanges and the pinch valve housing flanges must be even.

## Install the PV1 pinch valve

---

1. Loosely attach the pinch valve to the silo with three of the four M16 screws and nuts. Position the pinch valve so that the solenoid points away from the manifold and towards the corner of the silo where the pressure valve muffler is.
2. Install the gasket between the silo and the top of the pinch valve through the gap caused by the missing screw.
3. Loosely install the last M16 screw and nut.
4. Position the gasket around the center of the inner raised surface of the pinch valve, and then evenly tighten the four M16 screws and nuts. The gap between the silo flange and the upper pinch valve flange must be even after all of the screws are tight.
5. Position the gasket around the center of the vessel opening.
6.  Position the vessel under the pinch valve, and then attach it to the pinch valve with four M16 screws.
7. Evenly tighten the four M16 screws. The gap between the vessel flange and the lower pinch valve flange must be even after all of the screws are tight.
8. Install the new coupling in the vessel, and then attach the pneumatic manifold to the vessel coupling. Attach the hose and hose clamp.
9. Install the abrasive hoses and the air hoses to the vessel, pinch valve, and pneumatic controls. Connect the cables to the sensors and solenoids.
10. Connect the air source to the ADS.



**CAUTION!** Wear safety glasses during the test cycle and remain clear of the pinch valve.

11. Gradually increase air pressure of PR1 to 5.5 bar (80 psi) and then do a check for leaks.
12. Set PR1 and PR2 to the previous recorded pressures.
13. Fill the silo with abrasive.
14. Remove the lock from the power switch.



SHAPE TECHNOLOGIES GROUP®

## Troubleshooting the hopper with FlowSENSE

---

Reference the applicable error number/message below to find the troubleshooting steps to take.

**P394 » System: Abrasive Bulk Transfer Empty Shutdown**

Fill the silo with abrasive—you are out of abrasive and the ADS will remain stopped until filled.

**P395 » System: Abrasive Bulk Transfer Low Warning**

Abrasive level is low; fill the silo with abrasive soon.



SHAPE TECHNOLOGIES GROUP®

## Troubleshoot the CF900 hopper by symptom

---

### KEY

PR1 = Pinch valve pressure (Pinch valve)

PR2 = Conveying pressure (Vessel)

### No abrasive delivery even though there is enough abrasive in the ADS for operation

---

- PR2 may be set too low. Increase the pressure to PR2, but maintain at least a 3.45 bar (50 psi) difference between PR1 and PR2.
- Air and electrical supply connections may be interrupted. Inspect all air and electrical supply connections.
- The silo or vessel low-abrasive switch is malfunctioning. Test the function of the switches. If they do not function correctly, call Flow Service.

### No abrasive delivery, and the yellow warning indicator and/or the audible signal is not on

---

- The bulb to the yellow warning indicator may have burned out. Test the function of the indicator, and then replace the bulb if needed.
- Test the function of the audible signal, and then replace it if needed.
- If the container is empty and the indicator and audible signal are not on, call Flow Service.

### The abrasive metering valve runs dry between fill cycles

---

- PR2 may be set too low. Increase the pressure to PR2, but maintain at least a 3.45 bar (50 psi) difference between PR1 and PR2.
- Flowrate demand from metering valve exceeds 1.2 lb/min. Order a high flowrate kit for the valve. Call Flow Service for more information.



## Abrasive ejects from the top of the abrasive metering valve during normal operation or before a fill cycle

---

- Check the mesh size of your abrasive. The minimum size that can be used with the ADS is 120 mesh.
- PR2 may be set too high. Decrease the pressure to PR2, but maintain at least a 3.45 bar (50 psi) difference between PR1 and PR2

## ADS continuously vents

---

- There may not be enough of a pressure difference between PR1 and PR2. Adjust the pressure until there is at least a 3.45 bar (50 psi) difference between PR1 and PR2.
- The venting valve may be malfunctioning. Clean the valve. If this does not work, it may have to be replaced. Call Flow Service!

## Air and/or abrasive leaks from the silo

---

- PR2 may be set too high. Decrease the pressure to PR2, but maintain at least a 3.45 bar (50 psi) difference between PR1 and PR2.
- The PV1 pinch valve seal is defective. Install a new seal.

## Air leaks from the silo after a fill cycle and the vessel is unable to pressurize

---

- Make sure your air supply is at least 6.9 bar @ 566 L/min (100 psi @ 20 scfm).
- Increase your air supply to 8.3 bar (120 psi) maximum.
- Install an air receiver tank just before the ADS. A 56 liter (15 gallon) receiver should be sufficient.

## ADS does not convey enough abrasive

---

- The abrasive demand may be too high.
- The outlet opening on the vessel may be contaminated or blocked. Examine the outlet opening in the vessel for contamination and foreign objects. Look for restrictions in the hose between the vessel and the waterjet machine. Look for restrictions in the abrasive metering system.

## Air continually vents from the pressure regulators

---

- Your air supply pressure may be too high. Ensure your air supply is 6.9–8.3 bar (100–120 psi).