



MACH 500 OPERATION & MAINTENANCE MANUAL

M-806 | REV. A | APRIL 2017

CONTENTS

About this content	4
What changed?	4
Safety	5
Intended use	5
Intended user	6
Modifications	6
Transport	6
Disposal or recycling	7
Safety messages	7
Keep a clean work environment	8
Safety while cleaning	8
Safety during operation	8
Safety during maintenance	10
Electrical safety	11
Exceptional or emergency situations	12
Safety equipment	13
Safety labels	14
Personal Protective Equipment (PPE)	18
Emergency medical information	19
Lockout/Tagout (LOTO)	20
Overview	21
Specifications	22
Facility requirements	23
Component ID	26
Options	27
Operation	28
Machine interface	28
Start-up inspection	30
Start the machine	31
Stop the part program	32
End the part program	33
Emergency stop	33
Recover from an error	34

Shut down the machine.....	34
Maintenance	35
Preventative maintenance schedule.....	35
Torque specification.....	36
Recommended cleaners & lubricants.....	36
Inspect the mixing tube.....	37
Flush the mixing chamber vent.....	38
Dynamic Waterjet height sensor calibration	39
Dynamic Waterjet straightness adjustment.....	39
Dynamic XD calibration	40
Clean the diamond orifice & nozzle nut.....	61
Replace the diamond orifice.....	63
Troubleshooting.....	65
Troubleshooting with FlowSENSE.....	65
Dynamic Waterjet	65
Dynamic XD	74
Troubleshooting the on/off valve	83
Install the on/off valve seal kit	86
Standard Waterjet or Dynamic Waterjet	86
Dynamic XD	91
References	98
Service & Support.....	98
Spares & Consumables.....	99

About this content

Disclaimer

Due to continuing product improvement, the information contained in this document is subject to change without notice. Flow International Corporation shall not be held liable for technical or editorial omissions made herein, nor for any incidental or consequential damage resulting from the use of this material.

Registered trademarks

Dynamic Waterjet® , FlowCUT®, FlowMaster® , PASER ®, and XD® are registered trademarks of Flow International Corporation.

Windows is either a registered trademark or trademark of Microsoft Corporation in the United States and/or other countries.

All other registered trademarks shown are the property of their registered owners.

Copyright

This content contains information protected by copyright. No part of this document shall be reproduced in any manner without prior written consent from Flow International Corporation.

©2017 Flow International Corporation. All rights reserved. ORIGINAL INSTRUCTIONS.

What changed?

Includes a summary of changes to technical content by revision.

Revision A | April 2017

Initial release of Mach 500 content in English.

Safety



IMPORTANT! READ CAREFULLY BEFORE USE. KEEP FOR FUTURE REFERENCE.

Intended use

The machine is used to cut a number of different materials. The machine is designed to cut materials that can be directly applied to the material plate.

Additional applications such as cleaning or shaping by means of material removal, or special surface treatment (surface consolidation) is also possible, but only with appropriate adjustments to the machine, which must be discussed with the manufacturer. If necessary, a new conformity evaluation must subsequently be made. Additional guidelines may then apply.

Any other use of the machine is not in accordance with its intended use and therefore not permissible.

In particular, the machine is not meant for the processing of explosive materials or such materials that release explosive emissions. The machine may not be operated in explosive areas. In addition, the machine is not designed for the processing of food stuff.

The discharge direction of the waterjet is always downwards into the catcher. Flow assumes no liability for damage to the system or to persons which result from applications that deviate from intended use.

The operator (employer) is responsible for the intended use according to the specifications of the distributor (Flow Europe).

For other uses and when there is alteration to the machine by the operator/user after distribution by the manufacturer, the conformity of the machine to the requirements of the EC directives and standards confirmed by Flow Europe no longer applies and the CE Mark must be removed.

The machine may only be operated in a correct technical condition, in accordance with the applicable ordinances, in a safe and responsible way. The operating instructions of the components are to be observed.

Any other or expanded use is not as intended and not permitted.

Since the waterjet cutting machine can be used for a large number of materials in the most various industrial sectors, the responsibility for the use lies with the operator.

The machine is outfitted with safety equipment at the factory. This safety equipment should be regularly tested and used

If a delivery of the machine without this safety equipment should be contractually stipulated, then the machine is delivered without a CE Declaration of Conformity or CE Mark, but with a manufacturer's declaration. In this case, it is the responsibility of the operator of the system to install appropriate safety equipment, or to take appropriate operational measures to make the unit safe and to operate it according to the guidelines.

Intended user

The machine may only be operated and maintained by Flow-trained personnel. Work on the electrical or control system may only be done by trained, certified electricians. Service work may only be done by Flow personnel.

Modifications

Modifications to the system, including all machine, pump, cutting head, or software components, is prohibited. We recommend the exclusive use of original replacement parts.

Transport

Always disconnect the power supply and empty the catcher tank—even if the machine is only moved a short distance.

Load and unload all equipment with a properly rated forklift in accordance with local regulations. We recommend that you have flaggers and spotters present while you load or unload equipment. Never walk under a hanging load.

Secure the load so that it does not move during transport.

Disposal or recycling

Dispose of or recycle the machine in accordance with all local regulations.

Safety messages

In our content, safety messages are highlighted with the safety alert symbol and a signal word or only a signal word panel. Pay attention to these safety messages—they alert you to hazardous situations!

Safety alert symbol



This is the safety alert symbol. It is used to alert you to potential physical injury hazards. Obey all safety messages that follow this symbol to avoid possible injury or death.

Signal words

WARNING! WARNING indicates a hazardous situation, which if not avoided, could result in death or serious injury.

CAUTION! CAUTION indicates a hazardous situation, which if not avoided, could result in minor or moderate injury.

Signal word panels



DANGER indicates a hazardous situation, which if not avoided, will result in death or serious injury.



NOTICE indicates a non-hazardous situation, which if not avoided, could result in property damage.

Keep a clean work environment

- Keep the area around the machine clean and free of obstacles.
- Keep the floor clean and dry—abrasive residue, material dust, and water make the floor slippery. We recommend that you use grid plates or anti-slip mats to reduce the risk of slipping.
- Do not use any part of the machine as a place to store things.

Safety while cleaning

- Do not clean any part of your machine with the high-pressure water stream.
- Only use recommended cleaners (or equivalents) to clean your machine. Follow the safety instructions given by the manufacturer of the cleaner.
- Only use cleaners in well-ventilated areas. Avoid prolonged breathing of fumes and contact with skin or eyes.

Safety during operation

- The waterjet stream can sever or severely injure human extremities. Do not allow the waterjet stream to touch any part of your body. Do not point the waterjet stream at anyone. Do not put anything in its path that you do not intend to cut.
- Do not operate the machine without functional light curtains. Do not step inside the light curtain boundary at any time during operation. Make sure there are no people or objects inside the light curtain boundary before you start the machine.
- Don't start the system unless you know how to stop it.
- Do not leave the machine unattended. Be alert at all times while the machine is in operation.
- Do not touch high-pressure components when they are pressurized.
- Never try to support the workpiece by holding it with your fingers, either above or below the workpiece—the jet retains almost all of its cutting power below the work.

- Never put your hands in the tank when the machine is operating. Plan material clamping carefully in advance, so you never need to handle material or parts while the machine is operating.
- Never climb on or around the equipment on makeshift devices. Use only approved catwalks, ladders, or platforms.
- Never walk directly on the catcher tank slats to remove parts. Slat can weaken over time and fail.
- Always use the appropriate lifting equipment to move material on and off the work platform.

Abrasive

Garnet is the most frequently used abrasive. It is generally considered inert and has no known health hazards. NEVER use silica sand as an abrasive—the dust produced causes silicosis, a lung disease.

Never disconnect abrasive feed lines while under pressure. This can cause abrasive to spray into eyes.

Operator position and machine access

The machine meets the regulations for safety when approaching dangerous areas: EN 349; EN 999

The machine is not accessible and may not be loaded over the permissible work piece loading guidelines.

Noise emission

During the normal cutting operation—with the bottom of the material to be cut under water—the distance of the nozzle exit to the material smaller than 2.5 mm – the noise emission is under 85 dB(A).

However, under certain circumstances, the machine causes higher noise emissions. At the start of material drilling or cutting above the water, the noise level can climb over 115 dB(A). Always wear hearing protection. The longer the jet, the higher the noise level.

Under certain circumstances, the area surrounding the machine can amplify sound effects, which must be noted.

If the surrounding area becomes noisy, the sound from the adjacent areas must be monitored and the necessary measures taken.

Safety during maintenance

- Be alert at all times when doing maintenance on the machine.
- Do not patch damaged hoses—replace them.
- High-pressure water can remain in the system for an extended time after shutting down the water source. Always bleed-down system pressure before servicing any part of the system.
- Do not exceed specified pressure setting limits for pneumatic or hydraulic components. Exceeding these limits may result in serious injury to personnel or damage to the equipment.
- Torque all fittings to the manufacturer's torque specifications.
- Follow the manufacturer's recommendations for maintaining the equipment, and use only original manufacturer replacement parts.
- Follow the manufacturer's system startup procedure to ensure safe operation.
- Use care when lifting equipment covers during operation.

High-pressure system safety

- Do not patch high-pressure tubing—replace it.
- Welding on high-pressure component or high-pressure tubing is forbidden.
- Do not step on or lean against high-pressure tubing. Doing so could cause leaks.
- Do not touch weep holes with your bare hands or try to stop water by plugging the holes.
- Use only high-pressure fittings, valves, and tubing certified for the proper pressure for your equipment (60,000 psi/4150 bar for 60K systems, 94,000 psi/6500 bar for HyperJet systems) when making changes to the high-pressure water system.
- Do not exceed specified operating pressures for high-pressure water system components.

Tools

- Based on your machine configuration, special tools could be provided for certain work. Always use these tools for the work intended. Follow the procedures for using the tool(s) so that you do not hurt yourself or damage components.
- If instructions call for the use of a certain tool, only use the tool specified so you do not injure yourself or damage components.

Electrical safety



Life threatening danger due to surge! Always assume that electrical components are live.

Always turn the main switch to the system off when working on the electrical system. Post a sign “Maintenance in Progress—Do Not Energize.”

Work on the electrical or control system may only be done by trained, certified electricians. Work must be done in accordance with respective guidelines.

Instructions for the electrician

- If it necessary to work on live components, then a second person must be available to turn the unit current off at the main switch in case of emergency.
- The main switch must always be turned off during maintenance work and service work on the machine. It must be secured against unintentional activation with a lock for the length of the work.
- To protect sensitive components in the machine control, the electrician must ground themselves before working at the control computer and the PLC control.
- Only specified safety mechanisms of equal power and inertia should be used.
- Only measuring tools in accordance with respective guidelines should be used.
- Always take great care when the electrical system is being worked on.
- Only use insulated tools when working on the electrical system.

- All replacement wires or cables must conform to the manufacturer's specifications, including color coding, wire numbers, and size.
- When working on high-tension components, the phases behind the main switch should be grounded and any existing power capacitors discharged.

Exceptional or emergency situations

Contact with special materials

Note the safety datasheets of the manufacturer when you handle colors, solvents or special substances.

Such substances must be stored in accordance with applicable ordinances (Operational Facility Ordinance).

Note the local wastewater regulations.

Electrostatic discharges

During cutting, the high flow rate of water and abrasive could cause electrostatic charging. Discharges could lead to the ignition of flammable substances, dust, or gases. Ground all components so that static electricity does not form a spark.

The machine comes with the appropriate grounding cables. If the cables are defective, replace them immediately.

Emissions

Always pay attention to the data sheets of the material being cut! Although rare, flammable gases could develop in the water if you cut materials (such as aluminum) that lead to aggressive oxide formation. Work in a well-ventilated area to minimize exposure to vapors that could occur.

To avoid deflagrations, lower the water level in the catcher tank until the water is under the bottom of the material.

Explosions

Do not operate the machine in areas that are vulnerable to explosions.

If you weld, do flame cutting, or use an angle grinder in close proximity to the machine, clean the surrounding area and remove flammable materials. Under certain conditions, material dust can lead to deflagration or explosion.

Fire

If you cut flammable or difficult-to-extinguish materials, pay particular attention to fire prevention/extinguish protocols.

Familiarize yourself with the exit routes at your facility. Know how to trigger a fire alarm. Know where fire extinguishers/blankets are located and how to use them. Know what the appropriate extinguisher is to use for the materials you process.

In the event of a fire, keep calm. Call the fire department, and follow evacuation protocols.

Safety equipment

Make sure the safety equipment is functional before you put operate the machine and after you clean or do maintenance on the machine.

Emergency stop button (E-stop)

Make sure you know the location of the E-stop button and that it is functional before you start the machine. In the event of an emergency, press the E-stop immediately. This will disconnect the circuit and deactivate control voltage. In turn, the drives, pump, high-pressure water stream, and abrasive flow are disabled.

Light curtains



WARNING! Do not operate the machine without the light curtains!

The light curtain safety barrier must be operational at all times, except when the machine is shut down for maintenance. When the sensor is cross or otherwise activated, the machine automatically switches into set-up mode and the following occurs:

- Part program stops and error message is displayed
- Axes travel stops or is reduced to 2 m/min
- On/off valve closes
- High-pressure pump is shut off and high-pressure lines are depressurized

Safety labels

Safety labels alert you to a hazard. Do not remove the labels from the machine. If a label becomes illegible or damaged, replace it immediately.

Hazard alert labels



These labels warn you of hazards which could result in personal injury.

Label	Location	Hazard
	Front and rear sides of catcher tank	General warning
	Front side of interface enclosure (3x) Left side of left riser Right side of right riser Rear side of roll-around control Top of motor drives enclosure	Risk of electrical shock
	Rear side of catcher tank	Protective Earth Ground

Label	Location	Hazard
	Front and rear side of catcher tank	Risk of slipping due to wet or slick surfaces.
	Front side of Z-axis cover	Cutting of fingers due to pressurized water.
	Each corner of the catcher tank.	Hand crush due to moving parts.
	Right and left side of Z-axis cover Front and rear side of each riser	Body crush due to force from side.
	Left side of left riser Right side of right riser Top of motor drives enclosure	Hand entanglement due to belt drive.

Mandatory action labels



These labels inform you of actions to take to avoid hazards that could result in personal injury.

Label	Location	Action to take
	Front side of roll-around control	Wear a dust mask.
	Front side of roll-around control	Read the manual before operation.

Label	Location	Action to take
	Front side of roll-around control	Wear eye protection.
	Front side of roll-around control	Wear ear protection.
	Front side of roll-around control	Wear protective clothing.
	Front side of roll-around control	Wear protective gloves.
	Front side of roll-around control	Wear safety footwear.
	Front side of interface enclosure	Lockout/Tagout

Prohibited action labels

These labels inform you of actions that are prohibited because it could result in personal injury.

Label	Location	Prohibited action
	Front and rear of catcher tank.	Do not step.
	Light curtains	Do not enter. Authorized personnel only.

Personal Protective Equipment (PPE)

Personal protective equipment (PPE) is equipment worn to minimize exposure to serious workplace injuries and illnesses. All PPE clothing and equipment should be of safe design and construction, and should be maintained in a clean and reliable fashion.

We recommend your safety personnel approve all PPE for anyone who works around high-pressure waterjet equipment.



Wear a mask!

Wear a dust mask to reduce particle or dust inhalation when you fill the abrasive delivery system with abrasive.



Wear eye protection!

Wear safety glasses with side shields or safety goggles to shield your eyes from flying debris and spray.



Wear ear protection!

Wear ear protection



Wear protective clothing!

Wear protective clothing to shield your body from flying debris and spray.



Wear protective gloves!

Wear protective gloves when you handle sharp catcher tank slats or have to work around dirty water in the catcher tank.



Wear protective footwear!

Wear steel or composite toe footwear.

Emergency medical information



WARNING! Obtain medical treatment immediately for ANY high-pressure waterjet injuries. Even minor injuries that are painless or inconspicuous can lead to grave health problems.

It is vital that medical personnel have information about this type of injury. We recommend that anyone who works with high-pressure waterjet equipment carry a waterproof medical alert card. This card should describe their work and the nature of injuries inherent in using waterjets. You should also inform medical personnel what type of abrasive you used and the type of material you cut.



Lockout/Tagout (LOTO)

Only trained personnel can do Lockout/Tagout. These instructions are supplemental to your facility lockout/tagout procedures. We recommend your safety personnel approve all Lockout/Tagout instructions for anyone who works around high-pressure waterjet equipment.

1. Jog the cutting head to a loading or safe position.
2. Exit all programs.
3. Press the E-stop.
4. Click **Start**, and then click **Shut down** to turn off the machine PC.
5. Wait until the machine PC is completely shut down, and then turn off the main power to the machine (pump and machine disconnect).

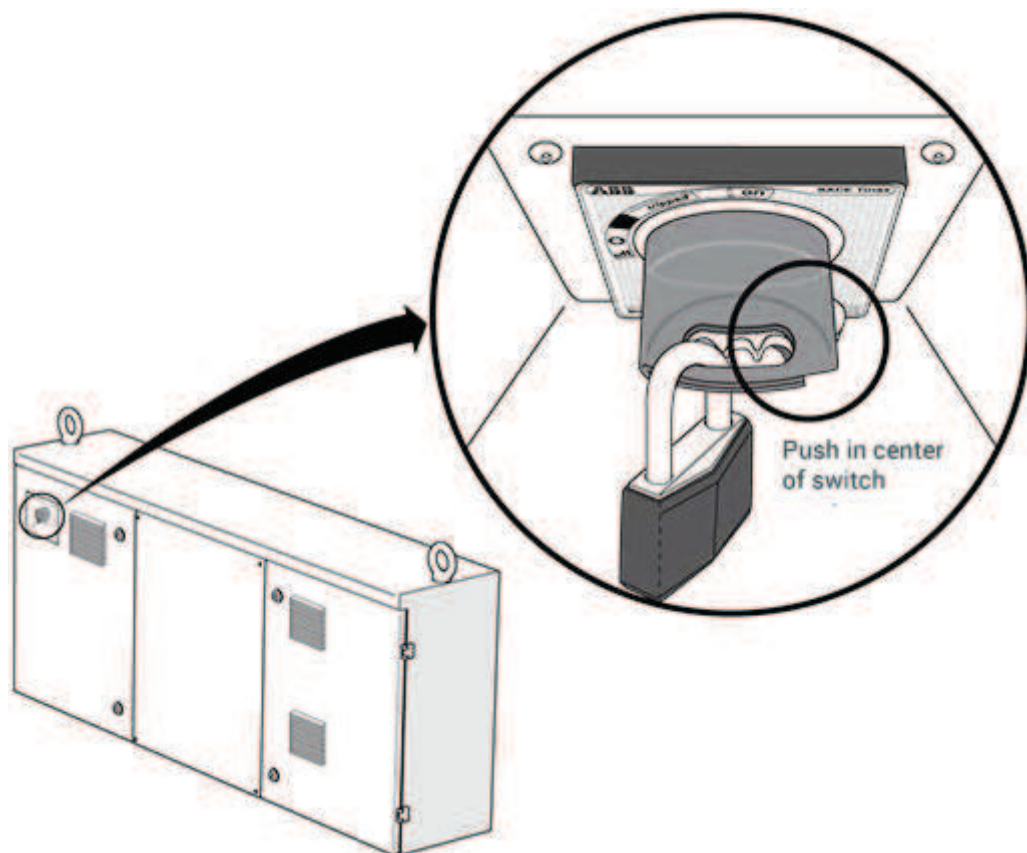

6. Turn off the air and water supply.

Overview

Mach 500 is more than a waterjet – it is a total solution. Unmatched technology and support delivers the ultimate in uptime and productivity. Cut more parts with unrivaled accuracy, elevating your production & performance levels.



Specifications

Machine specifications

Z-axis travel	305 or 610 mm (12 or 24 in.), based on your configuration
Rapid traverse maximum	17.78 m/min (700 in./min)
Contouring speed maximum	7.6 m/min (300 in./min)
Linear straightness accuracy	± .03 mm/m (.0012 in./3 ft)
Repeatability	± .03 mm (.001 in.)
Temperature tolerance band	20° ± 3° C (68° ± 5° F)

Operating parameters

Mixing tube	4 in. length
Stand-off	.010 in.
Dynamic Waterjet	10° rotation
Dynamic XD	Maximum 60° tilt

Facility requirements

Clearances

Local codes and regulations will determine the actual distance that is required for clearances. Obstructions include lights, sprinkler heads, or HVAC.

Recommended clearance each side	1000 mm (39 in.)
Minimum vertical clearance	3810 mm (150 in.) unobstructed

Electrical

Power supply	3-phase
Voltage/frequency	480 VAC/60 Hz or 400 VAC/50 Hz
Main circuit breaker size	25 amp

Environment

Ambient temperature	15.5°–38°C (60°–100°F)
Recommended temperature	20° ± 3° C (68° ± 5° F)
Relative humidity	up to 90% @ 38°C (100°F), non-condensing
Airborne dust/contaminants	minimal
Radio frequency interference	minimal
Lighting	adequate to operate and service the machine

If large temperature changes occur within an undefined period, length variances exceeding specified tolerances could occur over the entire work envelope. The tolerances of parts cut in extreme heat will differ from those cut in extreme cold because of variances produced in both the machine's structure and expansion of the actual part.

Ethernet connection

Maximum cable length	76 m (250 ft)
----------------------	---------------

If a longer length of cable is required, you must install a switch near the interface enclosure to amplify the signal. Otherwise, it may not be possible to connect the machine to your network, and this will limit our ability to support the machine via VPN.

Foundation

Everything starts with a great foundation and your waterjet is no exception! If you do not have an adequate foundation, the accuracy of your machine is affected.

Your foundation must be:

- Free of expansion joints in the area that you plan to put your machine. (The purpose of expansion joints is to concentrate foundation movement and imperfections to these specific areas.)
- Structurally reinforced and undivided to ensure even settling, should any settling occur.
- Level to 20 mm (3/4 in.) across the span of the machine.
- Able to support the weight of the catcher tank when filled with dirty water.

Model	Weight filled with clean water	Weight filled with dirty water
2020	9,582 kg (21,124 lb)	16,030 kg (35,339 lb)
2030	13,093 kg (28,865 lb)	22,272 kg (49,102 lb)
2040	15,968 kg (35,204 lb)	27,525 kg (60,682 lb)
2060	22,355 kg (49,285 lb)	39,220 kg (86,465 lb)
2080	28,742 kg (63,365 lb)	50,516 kg (111,368 lb)
3020	12,574 kg (27,720 lb)	21,574 kg (47,562 lb)
3030	17,410 kg (38,382 lb)	30,280 kg (66,755 lb)
3040	20,975 kg (46,242 lb)	37,199 kg (82,010 lb)
3060	29,376 kg (64,764 lb)	53,133 kg (117,139 lb)
3080	37,777 kg (83,285 lb)	68,449 kg (150,904 lb)
4020	15,452 kg (34,065 lb)	26,805 kg (59,094 lb)
4030	21,115 kg (46,550 lb)	37,366 kg (82,377 lb)

Model	Weight filled with clean water	Weight filled with dirty water
4040	25,774 kg (56,822 lb)	46,266 kg (102,000 lb)
4060	36,097 kg (79,580 lb)	66,127 kg (145,786 lb)
4080	46,420 kg (102,338 lb)	85,191 kg (187,813 lb)

In abnormal cases where a poor foundation or unusual soil conditions are present, your machine could require an isolated monolithic foundation of adequate mass to resist both static and dynamic loads imposed by the machine. Consult a local structural engineer to obtain design input based upon your particular soil bearing and floor conditions

Plumbing

Air	
Supply	dry and filtered to 10 microns
Capacity	538 L/min @ 6.9–8.3 bar (19 scfm @ 100–120 psi) per Z-axis end effector
Interface type	¾ in. BSPTF
Drain	
Capacity	8 L/min @ 0 bar (2 gpm at 0 psi) minimum per cutting head
Interface type	1 in. NPT

Component ID

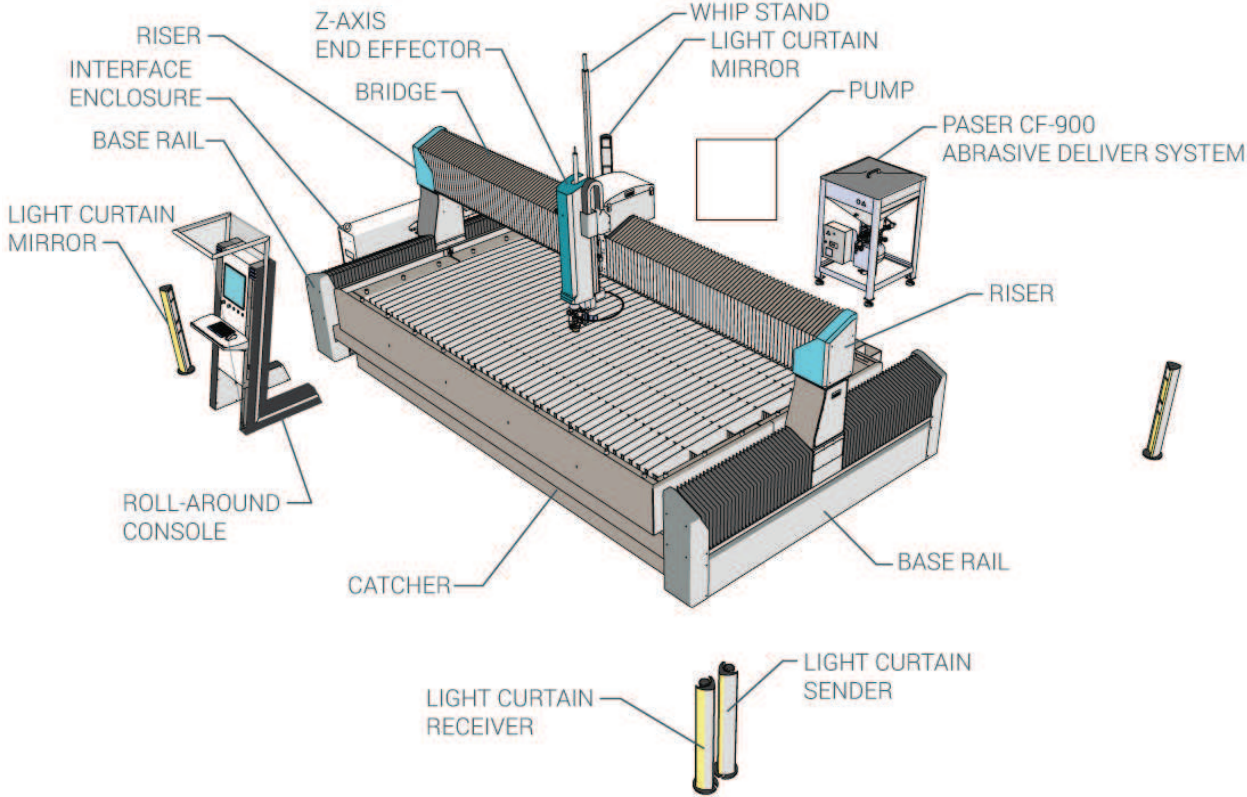

Options

Available options for the Mach 500 include:

Ultrahigh-pressure pumps

HyPlex Prime

ESL Intensifier

HyperJet

Software

FlowXpert® 3D CAD/CAM Package

FlowMaster® CAD/CAM Package

FlowCode G-Code Converter

FlowNest

CATIA Compatibility Package

Raster to Vector Conversion Software

Cutting heads

Pure Waterjet

Standard Abrasive Waterjet

Dynamic Waterjet

Dynamic XD

Multiple cutting heads

Ancillary

Paser CF-900 Continuous Feed Hopper

Compass™ 5-Axis Contour Follower

Dynamic Contour Follower™

UltraPierce™ Vacuum Assist

Abrasive Removal System

Stainless Steel Catcher Tank

Closed Loop Water System

Spray Containment Shields

Laser Edge Finder

Operation

Machine interface

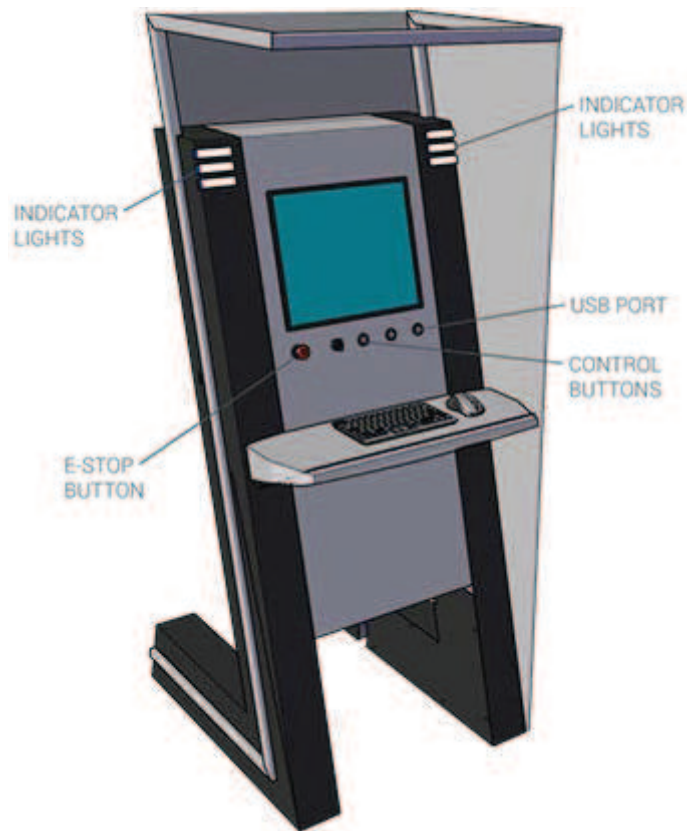

Buttons & USB Port



Buttons/USB Port	What does it do?
Emergency stop	Disables the drives, and stops the high-pressure water stream, abrasive flow, and the pump.
Reset	Resets the drives.
Cycle Stop	Pauses the part program and stops the high-pressure water stream and abrasive flow.
Power	Enables the drives.
USB Port	Connection point for peripherals. Keep the USB port covered with the cap when not is use to prevent corrosion.

Indicator lights

If the indicators are...	State	What does it mean?
Solid white	Standby	Initialization is finished, but all axes are disabled.
Solid white + the Power button is green	Manual state	The drives are enabled and you can jog the axes manually.
Solid blue	Automatic cycle	A part program is running.
Flashing white and blue	Jog	The machine is being jogged.
Solid red	Shutdown	The machine is stopped due to a fault condition.

Start-up inspection

The purpose of a start-up inspection is twofold: it ensures that your machine is safe to operate, and helps your operators find small problems before they become big ones. This means less unscheduled downtime and fewer repairs which ultimately improves your bottom line!

We recommend that you do each inspection at the specified point given when you [start your machine](#).

Inspection #1

- There is nothing on or around the table that will impede movement of the axes.
- All cover, panels, and doors on the machine are in place or closed.
- The catcher tank slats are in good condition.

Inspection #2

- The air and water supply to the machine are on.
- The inlet water and cooling water supply to the pump are on.

Inspection #3

- There is an adequate amount of oil in the pump.
- There is an adequate amount of abrasive in the hopper.
- Inlet water pressure is acceptable.
- Ancillary equipment, such as chillers or garnet removal systems, are on.

Inspection #4

- The pump is not leaking.

Start the machine

Follow these steps to start the machine from a cold start (no power).

1. If there is an customer-supplied main disconnect on the wall that feeds power to the machine, ensure this is turned on.
2. [Do Inspection #1.](#)
3. Turn on the pump disconnect
4. Turn on the main power disconnect switch that is on the machine interface enclosure and the disconnect switch on ADS.
5. [Do Inspection #2.](#)
6. Let the Windows® operating system start. Once a connection is established, the indicator lights will turn red.
7. Disengage the E-stop buttons on the roll-around control, the pump, and the ADS.
8. Press and hold the **Reset** button for two seconds—the indicators will turn white.
9. Press and hold the **Power** button for two seconds— this button will turn green, and the indicators will flash white to blue, and then turn white.
10. Start FlowCUT, and then click **Run Machine** .
11. Manually jog the cutting head to an open area of the table.
12. [Do Inspection #3.](#)
13. Start the pump in FlowCUT. verify pressure, look for leaks
14. [Do Inspection #4.](#)
15. Under **Water**, click , click , and then verify the water stream is concentric.
16. Under **Abrasive**, click , click , and then verify the abrasive is flowing.
17. Open a part file and cut parts!

Stop the part program

When you stop the part program, the high-pressure water stream and abrasive flow also stop.

To	Do this
Stop the part program	Click Cycle Stop . or Press the Spacebar. or Push the Cycle Stop button on the roll-around control.
Restart the part program	Click Cycle Start .
Resume the part program	<ol style="list-style-type: none">1. On the Cutting menu, click Cut from a point.2. Click on the point in the drawing “just before” the location where the program was stopped.3. When you receive the “Jet will move to this point and start the cut by USING CURRENT HOME POSITION” message, click Yes.

End the part program

When you end the part program, the pump, high-pressure water stream, and abrasive flow also stop.

To	Do this
End the part program	Press the Esc key.
Restart the part program	<ol style="list-style-type: none">1. Start the pump.2. Click Cycle Start.
Resume the part program	<ol style="list-style-type: none">1. Start the pump.2. On the Cutting menu, click Cut from a point.3. Click on the point in the drawing “just before” the location where the program was stopped.4. When you receive the “Jet will move to this point and start the cut by USING CURRENT HOME POSITION” message, click Yes.

Emergency stop

In an emergency, press the E-stop button on the roll-around control.

This will disable the drives, the high-pressure water stream, the abrasive, and the pump.

Reset after an E-stop

1. Make sure the danger or issue that prompted the emergency stop has been cleared.
2. Disengage the E-stop.
3. Click **OK** on the Pause/Shutdown message.
4. In the **FlowSENSE Diagnostics** dialog box, click **Acknowledge errors**, and then click **Close**.
5. Press and hold **Reset** button until the indicator lights turn white.

6. Press and hold the **Power** button until the indicator lights turn blue.

Recover from an error

If the machine experiences an event outside of normal operation, FlowCUT will display an Error Alarm with a pause/shutdown message on the console screen. Warning Alarms indicate a condition that prevents optimum performance of the machine. Error Alarms indicate a condition that requires the machine to shut down.

1. Correct the error.
2. Click **OK** on the Pause/Shutdown message.
3. In the **FlowSENSE Diagnostics** dialog box, click **Acknowledge errors**, and then click **Close**.
4. Press and hold **Reset** button until the indicator lights turn white.
5. Press and hold the **Power** button until the indicator lights turn blue.

Shut down the machine

Shut down your machine when shutting down for the night.

1. Jog the cutting head to a loading or safe position.
2. Exit all programs.
3. Press the E-stop.
4. Click **Start**, and then click **Shut down** to turn off the machine PC.
5. Wait until the machine PC is completely shut down, and then turn off the main power to the machine (pump and machine disconnect).

Maintenance

We recommend that you keep a log of maintenance work done on your machine.

Preventative maintenance schedule

What do I do?	When do I do it?
Start-up inspection	Daily
Inspect the mixing tube	Daily
Spray the mixing chamber vent with clean water.	Every four hours
Clean the cutting head with air.	Weekly
Dynamic Waterjet height sensor calibration	Weekly
Dynamic Waterjet straightness adjustment	Weekly
Lubricate the bearings and linear rails.	Weekly
Dynamic XD calibration	Monthly
Remove excess grease from the linear rails.	Monthly
Clean and inspect the bellows for rips.	Monthly
Clean the diamond orifice and nozzle nut.	Every 250 hours of operation
Replace the diamond orifice.	Every 1000 hours of operation
Call Flow to schedule a ball bar test.	Every six months

Torque specification

If a torque value for a gland nut is not specified, reference this table to determine torque value. Always leave 3–4 threads showing between the end of the high-pressure tubing and gland nuts.

If the high-pressure tubing OD is...	Then torque the gland nut to...
1/4 in.	20–34 N-m (15–25 ft-lb)
3/8 in.	47–60 N-m (35–45 ft-lb)
9/16 in.	80–100 N-m (60–75 ft-lb)

Recommended cleaners & lubricants

Item	Cleaner or Lubricant	How to
Rails	CRC Technical Grade 3-36® Multi-purpose Precision Lubricant or equivalent.	<ol style="list-style-type: none">1. Spray a light, even coat of cleaner on the rails.2. Allow time for it to penetrate the dirt and grease, and then clean it off with a clean, lint-free cloth.
Bellows and painted surfaces	Johnson Envy Instant Cleaner or equivalent.	Spray foam evenly over surface. Wipe clean with clean, lint-free cloth. Repeat as necessary.
Bearings and linear rails	AFF grease	—

Inspect the mixing tube

Inspect your mixing tube daily so you can monitor and limit ID growth.

1. Remove the mixing tube:
 - a. Turn off the high-pressure pump and bleed down all pressure from the system.
 - b. Unscrew the nut from the mixing chamber and remove the collet and mixing tube with it.
 - c. Use a compliant surface such as wood or plastic to press the mixing tube out of the collet and nut assembly.

NOTICE The mixing tube is brittle carbide. Do not bend it, drop it, or twist it.

2. Examine the mixing tube. Replace it if the mixing tube shows:
 - Prominent, off-center wear at the nozzle exit tip ID.
 - Chips in the downstream end, outside edge of the nozzle that originate at the outside diameter and leave less than 0.020 in. (0.508 mm) nozzle wall thickness.
 - Cracks that extend radially from the nozzle ID to OD, or that extend down the length of the nozzle.
 - Chips in either end of the nozzle that originate at the inside diameter.
3. Install a new mixing tube:
 - a. Snap the collet into the nut (if removed) and insert a new mixing tube into the collet and nut assembly.
 - b. Install the old spacer onto the mixing tube. Make sure the mixing tube collar is positioned correctly.

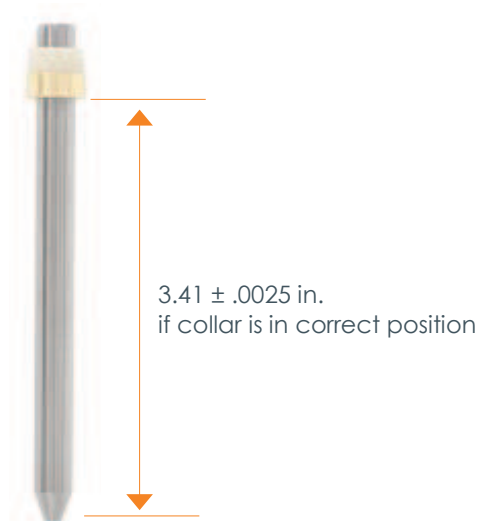

- c. Screw this assembly onto the mixing chamber and hand-tighten.

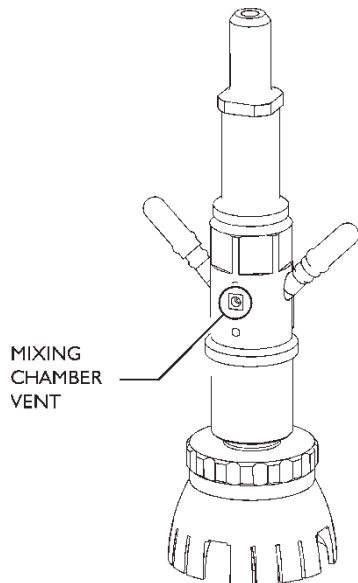

Flush the mixing chamber vent

Flush the mixing chamber vent with clean water to minimize residue build-up.

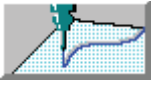

Dynamic Waterjet height sensor calibration

Calibrate the height sensor weekly.

1. Open a part file in FlowCUT, and then click **Run Machine** .
2. Home the machine.
3. Put your material on the work platform.
4. Clear the **Enable Height Sensor** checkbox.
5. Click **Option Component** . Select **Set TDP**, and then click **Close**.
6. Put the 0.1000 in. shim on the material.
7. Lower the Z-axis until the mixing tube “just touches” the surface of the shim.
8. In the **Homing** dialog box, click **Set current position as user home**.
9. Select the **Enable Height Sensor** checkbox.
10. Click **Option Component** . Select **Calibrate HS**, and then click **Close**.

Dynamic Waterjet straightness adjustment

Do a straightness adjustment weekly. See FlowCUT help files.

Dynamic XD calibration

Do a Dynamic XD calibration monthly.

Prep for success

TOOLS

- Angle block; 4 in.
(All surfaces square within 0.0005 in. per 6 in. and parallel within 0.00025 in. per 6 in.)
- C-clamp (or other method to clamp dial gauge to mixing tube)
- DynAlign station
- Dial gauge
- Dial gauge tip attachments: ball-nose & chisel



- Gauge block; Aluminum; 1.5 in.
- Hex keys; Metric
- Leveling plate (or other support material)
- Magnetic base

SUPPLIES

- Piece of stable, ferrous metal
- Scotch-Brite™ (Maroon or Green)
- USB flash drive

PRECAUTION

- Do not click **OK** or press **Enter** while you work in the **Straightness Adjustment** tab unless instructed to do so in the . If you do, the BC motor positions will reset, causing the calibration to fail.

Prepare to calibrate the wrist

Hardware

1. Turn your high-pressure pump and water supply off. Bleed down all high-pressure lines from the system.



WARNING! Failure to do so could result in injury to personnel or equipment damage.

2. Make sure cutting head assembly is seated and clamped properly into the flexure joint clamp. If necessary, remove clamp and clean components.
3. Remove the pierce shield, nozzle nut, mixing tube, and spacer from the cutting head and then do the following:
 - Clean the mixing tube with a piece of Scotch-Brite — particulates may distort the readings of the laser sensors.
 - Inspect the nozzle nut for damage and replace if necessary.
4. Install the spacer, mixing tube, and nozzle nut. Set aside the pierce shield.

Make sure the mixing tube collar is positioned correctly.

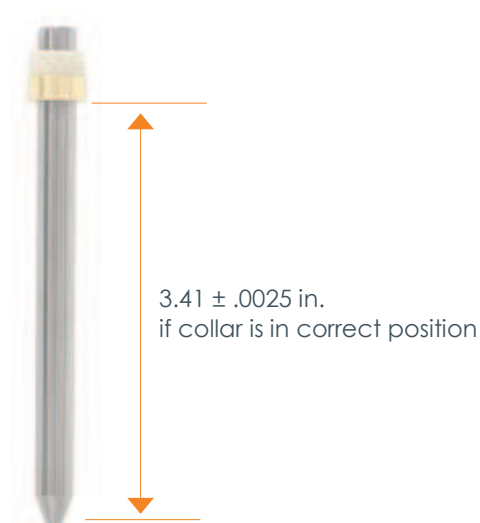

Have a Compass?

Also set aside the mixing tube spacer. Fully extend the mixing tube so there will be enough clearance between the Compass and DynAlign station. Remove the Compass ring assembly and attach the protective cover.

5. Loosen the gland nut on the on/off valve to remove torsion from the cutting head. Torsion could cause an undesirable rotation of the cutting head when adjusting the flexure joint.

Software

1. Browse to **C:\Program Files (x86)\Flow International\FlowCUT 7**, and then copy the **System** folder onto a USB flash drive.
2. On the machine PC, exit all programs that may be running.
3. Start FlowCUT. On the **File** menu, click **Open**, and then browse to **C:\Program Files (x86)\Flow International\FlowCUT 7\Calibration**. Double-click the **Trapezoid.ord** file.
4. On the **Setup** menu, point to **Dynamic Waterjet**, and then click **Dynamic Waterjet Setup**.
5. In the **Dynamic Waterjet Setup** dialog box, adjust the **Tool length** to 0 and the **Standoff** to 0.1. Click **OK**, and then exit **FlowCUT**.
6. Browse to **C:\Program Files (x86)\Flow International\FlowCUT 7**, and then double-click the **DynAlign XD Calibration.exe** file.

Did you receive a "Data cannot be written to the calibration2.ini or DWJ I. dh file" or other similar message?

Locate the file using Windows Explorer. Right-click on the selected file, and then click **Properties**. Clear the **Read Only** check box, and then click **Apply**.

7. In the DynAlign Calibration Utility, on the **Calibration Options** tab, click **Reset** to load factory defaults for the wrist (referred to as "loading a nominal DWJ I.dh file").

Do you have a Compass?

Also select the **Extend Mixing Tube (Due to Laser Height Setter/Compass)** check box.

Good to know!

The backup file is overwritten each time you click **Reset**. If you click **Reset** more than once, the backup file becomes the nominal file. Previous data is lost.

8. Depending on your configuration, click **Yes** or **OK** when you receive the “Confirm Backup” message.
9. On the **Jog tool** tab, jog the cutting head until it is a good working position.
10. Click **Set current position as user home**, and then click **Go to user home**. This allows the wrist to unwind to its home position.

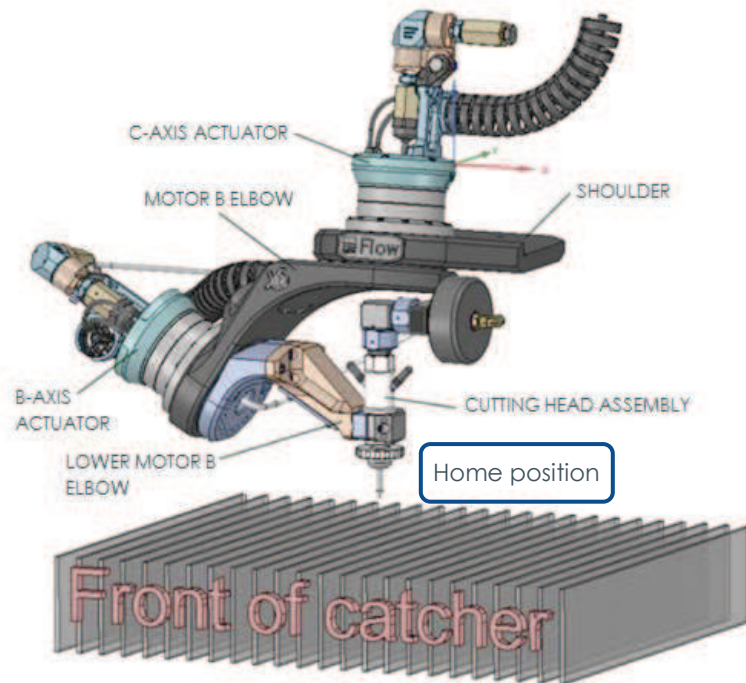

Move Motor B & C into the folded position

The following steps will help get the wrist as mechanically correct as possible, resulting in greater accuracy and tighter calibration.

Align the Motor B elbow bracket with the Y-axis





Coarse adjustment

- On the **Straightness Adjustment** tab, under **Motor C**, in the **Angle** box, type **93** and then click  until Motor B is pointing towards the back of the catcher tank (parallel to Y-axis).

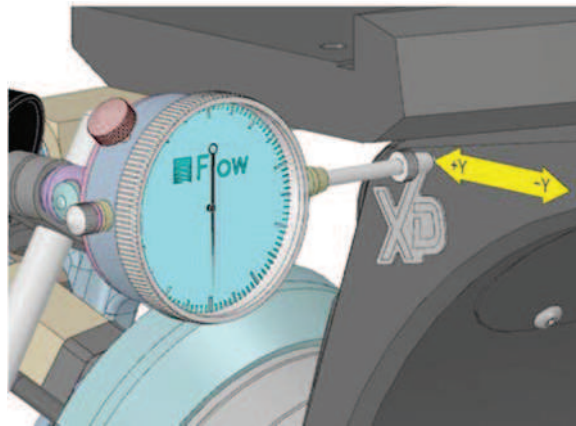

Fine adjustment

- Set the dial gauge (with ball nose tip) and magnetic base on a stable, ferrous piece of metal on the X-Y table.
- Clean the surface, and then position the tip of the dial gauge on the Motor B elbow bracket (flat portion of arm holding Motor B).



- On the **Jog tool** tab, clear the **Checked for continuous jog\Unchecked for step jog** check box.
- In the **Y-axis box**, type **2**, and then click  or  (based on gauge position) to jog the Y-axis. Observe the movement on the dial gauge.
- On the **Straightness Adjustment** tab, under **Motor C**, in the **Angle** box, adjust the value (if necessary) based on the amount of movement on the dial gauge, and then click  or .
- Repeat steps 4–5 until minimum motion (less than 0.001 in.) is detected on the dial.

Align the lower elbow arm with the Z-axis

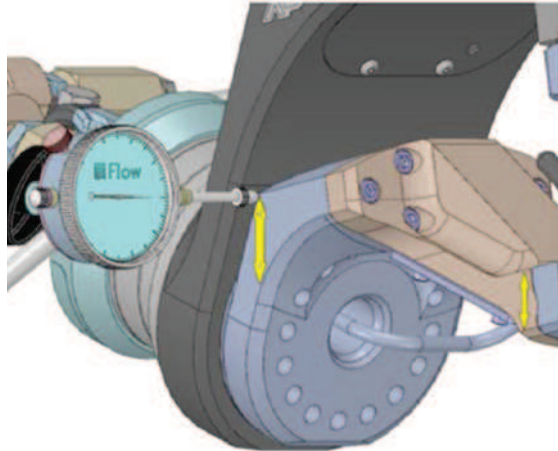

1. On the **Straightness Adjustment** tab, under **Motor B**, click  or  until the mixing tube is “visually close” to being parallel to the Y-Z plane.
2. Clean the surface, and then position the tip of the dial gauge on the lower elbow arm that holds the cutting head. Place the tip on the flat surface near Motor B.

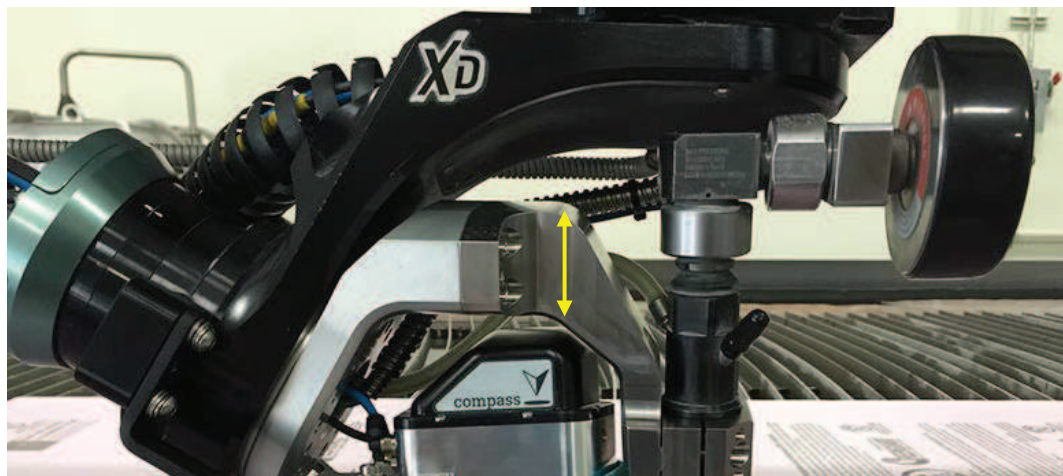

Dynamic XD without Compass





Dynamic XD with Compass

3. Under **Manual**, click  or  to jog the cutting head ± 1 in. in the Z-direction. Observe the movement on the dial gauge.

Do you have a Compass?

Jog the cutting head ± 0.75 inches in the Z-direction, not ± 1 inch..

4. Under **Motor B**, in the **Angle** box, adjust the value (if necessary) based on the amount of movement on the dial gauge and then click  or .

5. Repeat Steps 3–4 until minimum motion (less than 0.001 in.) is detected on the dial gauge.



Check the flat area behind the flexure joint

1. Move the gauge into position.

Do you have a Compass?

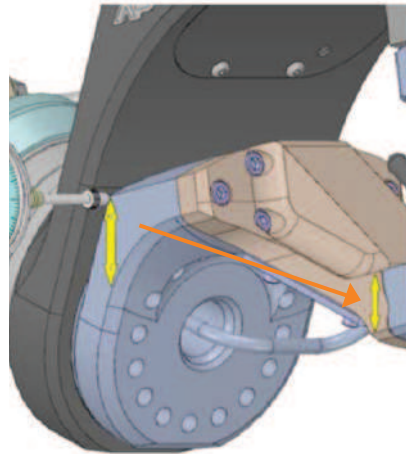
Skip this section, and go to [Move Motor B & C into the home position.](#)



2. Clean the surface. Position the tip of the dial gauge on the flat area just behind, but not on, the flexure joint.
3. On the **Straightness Adjustment** tab, under **Manual**, in the **Height** box, type **.75**, and then click  or  to jog the cutting head $\pm .75$ in. in the Z-direction. Observe the movement on the dial gauge.
4. Loosen the six bolts on the lower B-axis elbow and manually adjust the arm (if necessary) based on the amount of movement on the dial gauge.

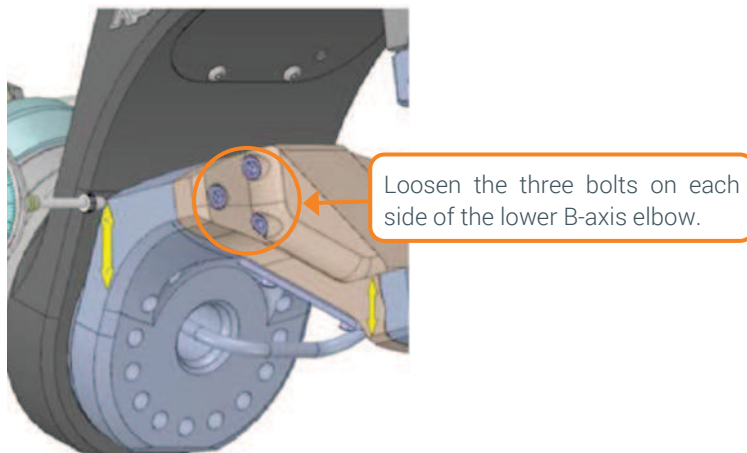



5. Repeat Steps 2–3 until minimum motion (less than 0.001 in.) is detected on the dial gauge.
6. Tighten the bolts and then remove the dial gauge.
7. Click **OK**, and then click **OK** when you receive the “The B, C, and Z axes will go to machine home...” message.



This will create a temporary home position. This position is the folded position.

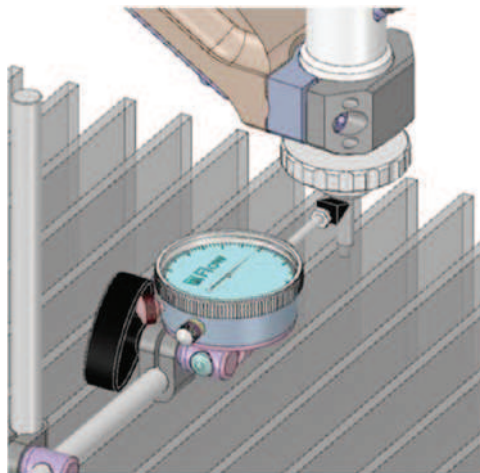

Move Motor B & C into the home position

Based off the B and C folded positions, the wrist assembly will be set as close as possible to the vertical home position. When complete, Motor B will be pointed to the left (when viewed from the front of the catcher tank) and the mixing tube will be vertical.



1. On the **Straightness Adjustment** tab, under **Motor C**, in the **Angle** box, type **93**, and then click . This moves the wrist such that Motor B will be pointed to the left (when viewed from the front of the catcher tank).
2. Under **Motor B**, in the **Angle** box, type **11.55**, and then click . Elbow brackets move into a near-home position, and the cutting head will appear close to vertical.
3. Attach a chisel point tip to the dial gauge, and position the gauge so that the axis of the gauge is in the Y-Z plane (parallel to the Y-axis pointing to the back of the catcher tank).
4. Position the dial gauge tip on the mixing tube.

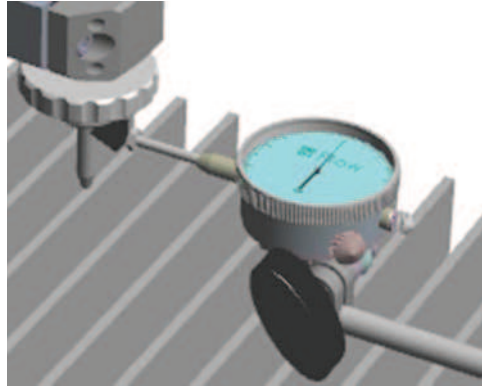

5. Under **Manual**, in the **Height** box, type **.75**, and then click  or  to jog the cutting head $\pm .75$ in. in the Z-direction. Observe the movement on the dial gauge.

6. Under **Motor B**, in the **Angle** box, adjust the value (if necessary) based on the amount of movement on the dial gauge and then click  or .
7. Repeat Steps 5–6 until minimum motion (less than 0.001 in.) is detected on the dial gauge.
8. Rotate the dial gauge until the axis of the dial gauge is in the X-Z plane (parallel to the X-axis pointing to the left from the front of the catcher tank).
9. Position the dial gauge tip on the mixing tube.



10. Under **Manual**, click  or  to jog the cutting head $\pm .75$ in. in the Z-direction. Observe the movement on the dial gauge.
11. Adjust the flexure joint adjustment screws with a 3 mm hex key, based on the amount of movement on the dial gauge.

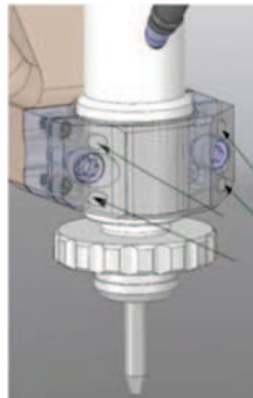

Tightening the top screws? Loosen the bottom screws first.

Tightening the bottom screws? Loosen the top screws first.

Why? It allows movement of the joint.

12. Repeat Steps 10–11 until minimum motion (less than 0.001 in.) is detected on the dial gauge, and then tighten all four screws down equally.

13. Record the absolute position of Motor B.

Motor B position: + _____

Motor C position: - 93

Disregard the signs of the numbers displayed in the Straightness Adjustment tab. Later, when you align the flexure joint, you will enter the values with the signs shown below.

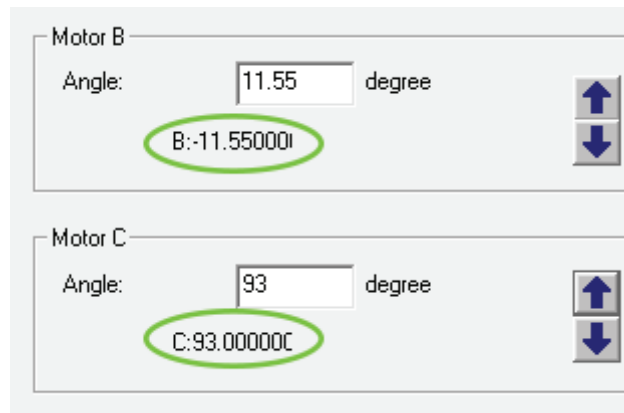

Motor B value should be close to -11.55°, but may vary depending on the mechanical stack-up of the wrist components.

Motor C value should always be 93°. If it's not, repeat this .

14. Remove gauge, and then click **OK**.

This will home the Z-axis, and Motors B & C will reference to zero degrees. This position is the home position.

Measure the Z-axis skew

This measures the distance that the Z-axis is skewed from the X-Y plane and provides values to be used by the software calibration. Ensure the Z-axis is visually vertical, or close to vertical, during the measurements. A small amount of Z-axis skew is compensated by software.



The Z-axis carriage must be located in the middle of the bridge (X-axis) before you start measuring. Jog the carriage with the **Jog tool**.

Measure the X-deviation value

1. Prepare a flat surface, parallel to X-Y motion, for the angle block. Shimming may be required if fixture is not available.

Make sure the material is clean, flat, and large enough to support tools without compromising Z-axis travel. Do not use catcher slats as a support—slats are not a stable base.

2. Set the support material at least 450 mm (18 in.) back from the front edge of the catcher tank. In case Motor B swings forward, it will not come in contact with catcher tank.
3. Place the angle block to the right (+X) of the cutting head. Attach the dial gauge (with ball nose tip) to the cutting head.
4. Position the tip towards the back of the catcher tank, at the top of the angle block. Allow for 2 inches of downward travel. Zero the dial gauge.

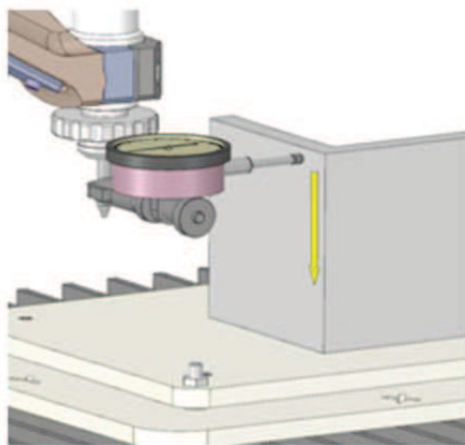

5. On the **Jog tool** tab, jog the Z-axis:
 - a. Clear the **Checked for continuous jog\Unchecked for step jog** checkbox.
 - b. In the **Z-Axis box**, type **2**, and then click  to start the jog.
6. Look at the dial gauge, and then record the value of the X-deviation. Make sure to record whether the movement is a positive or negative value.

Good to know!

When the plunger of gauge is pushed in, the needle will rotate. If it rotates clockwise, it is a positive (+) movement. If it rotates counterclockwise, it is a negative (-) movement.

Measure the Y-deviation value

1. Place the angle block to the rear (+Y) of the cutting head.
2. Position the tip towards the back of the catcher tank, at the top of the angle block. Allow for 2 inches of downward travel. Zero the dial gauge.

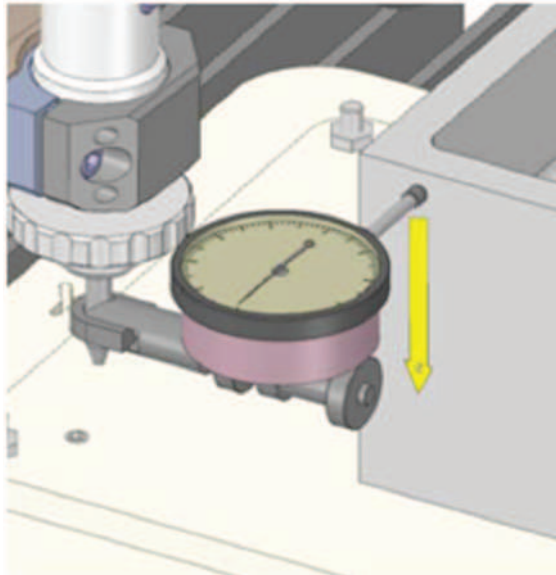

3. On the **Jog tool** tab, jog the Z-axis:
 - a. Clear the **Checked for continuous jog\Unchecked for step jog** checkbox.
 - b. In the **Z-Axis box**, type **2**, and then click  to start the jog.
4. Look at the dial gauge, and then record the value of the Y-deviation. Make sure to record whether the movement is a positive or negative value.

Adjust the X & Y deviation values

1. On the **1. Z-axis skew** tab, in the **X deviation** box, type the value you recorded from above.
2. In the **Y deviation** box, type the value you recorded from above, and then click **Apply**.

Square the DynAlign to the X,Y axes

1. Put the DynAlign station on the support material, and then turn it until the electrical connector faces toward the front and left of the tank.

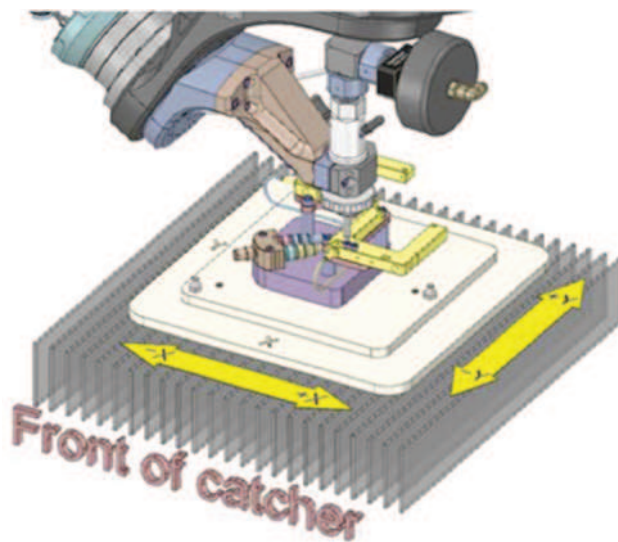

2. Align the two U-shaped gates along the X and Y axes.

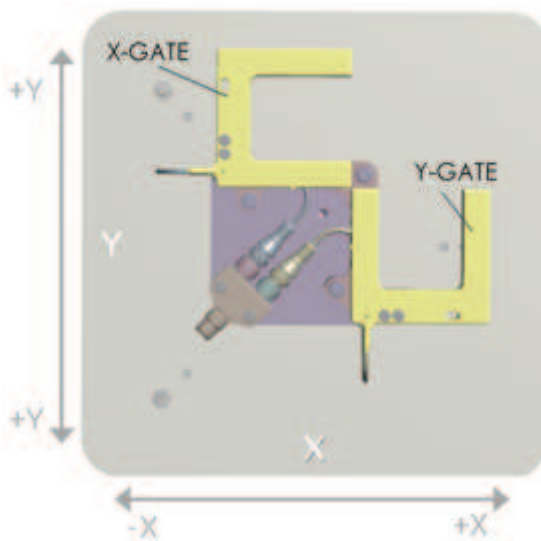

Move to starting point

1. On the **Jog tool** tab, clear the **Checked for continuous jog\Unchecked for step jog** checkbox.
2. Type an appropriate value in the **X-Axis**, **Y-Axis**, and **Z-Axis** boxes.
3. Use the **Jog controls** to jog the mixing tube until it is centered over the starting point, with 0.030–0.040 in. standoff.

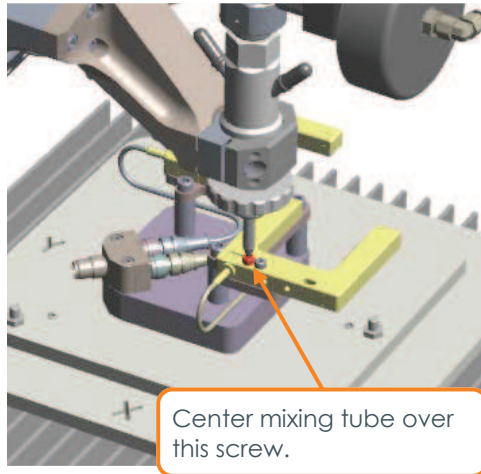

Check squareness

1. On the **2. DynAlign sensor** tab, under **Y-axis gate**, click **Check Y-axis gate**, and then follow the instructions in the **Adjustment** box.

When rotating the Y-gate, rotate the DynAlign station with the center of rotation being starting point on the Y-gate of the DynAlign station.

Good to know!

If the mixing tube is about to collide with the light gate, click **STOP**. Click **Move home**, and then start over.

2. Under **X-axis gate**, click **Check X-axis gate**, and then follow the instructions in the **Adjustment** box.

When rotating the X-gate, slightly loosen the two adjustment screws attaching the X-gate to the DynAlign station if necessary. When moving the X-gate, hold the DynAlign station securely in place so that only the X-gate is adjusted. Tighten the adjustment screws when finished.

3. Confirm the X and Y gates are aligned. A difference of ± 0.003 in. is acceptable. Do one of the following:

- Click **Check squareness**, and then follow the instructions in the **Adjustment** box.
- Repeat steps 1 & 2 until proper squareness is obtained.

Align the flexure joint

This ensures the flexure joint of the cutting head is properly aligned. Since the flexure joint was positioned properly during previous steps, only minor adjustments should be necessary at this stage. When the flexure joint is adjusted properly, the axis of the mixing tube lies parallel to the imaginary line drawn along the center of rotation of the C-motor.

1. On the **3. Flexure joint alignment** tab, in the **B-folded position** box, type the positive *value* recorded when Motors B & C moved into home position. In the **C-folded position** box, type **-93**.

The screenshot shows a control panel titled "3. Flexure joint alignment". Under the "Motor-B adjustment" section, there are two input fields: "B-folded position" with the value "11.55" and "C-folded position" with the value "-93". Below these are two buttons: "Check motor-B" and "Auto adjustment". To the right of the buttons are three input fields: "Top difference" (inches), "Bottom difference" (inches), and "Target difference" (inches).

2. Click **Check motor-B** to display the vertical differences, from top to bottom, of the mixing tube.
3. Click **Auto adjustment** to correct the differences. It may take a few minutes for this to be completed. Ensure the **Target difference** is less than 0.001 in. when adjustment is complete.
4. Under **Flexure joint adjustment**, click **Check Flexure joint**. Ensure the **Target difference** is less than 0.002 in. when adjustment is complete.

Not within range?

Follow the instructions in the **Adjustment** box. Make adjustments with a 3 mm hex key. After you reach the target difference, tighten all four screws equally, and then click **Check Flexure joint** to verify.

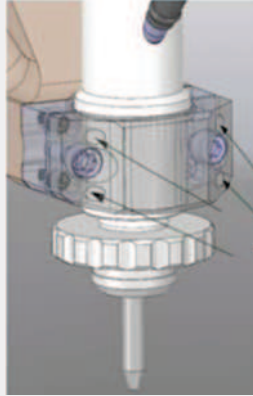

Tightening the top screws?

Loosen the bottom screws first.

Tightening the bottom screws?

Loosen the top screws first.

Why?

It allows movement of the joint.

5. Click **Apply** after the adjustment is complete.

Measure the angular parameters

This takes multiple measurements of the mixing tube while it is tilted at 20°, 8°, and 15°. Each time the angle changes, the program takes readings of two points in the Z-direction of the mixing tube in the X-axis gate and Y-axis gate. Then it will rotate the wrist and repeat until completing measurements around 360° of rotation. The program will then use the measurements to calculate the DH parameters and modify the DWJ I.dh file.

1. On the **4. Angular parameters adjustment** tab,
2. Click **Move Home** to align the mixing tube over the starting point.

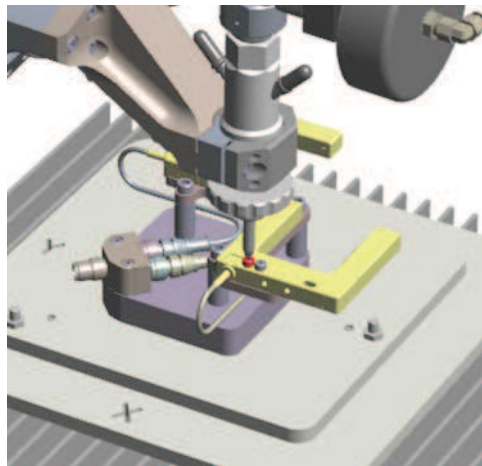

3. Click **Start Measurements**.

Did you receive a “The maximum angle error is bigger than 0.2 degrees” message?

Make a note of it, and then click **OK**. This is diagnostic information only and does not impact calibration.

4. Remove the DynAlign station from the X-Y table when the routine is complete.

Adjust the S5 & a56 DH parameters

Motor C rotates Motor B through the X and Y planes. When the S5 and a56 parameters are perfectly adjusted, the tool tip will have minimal motion when Motor C rotates.

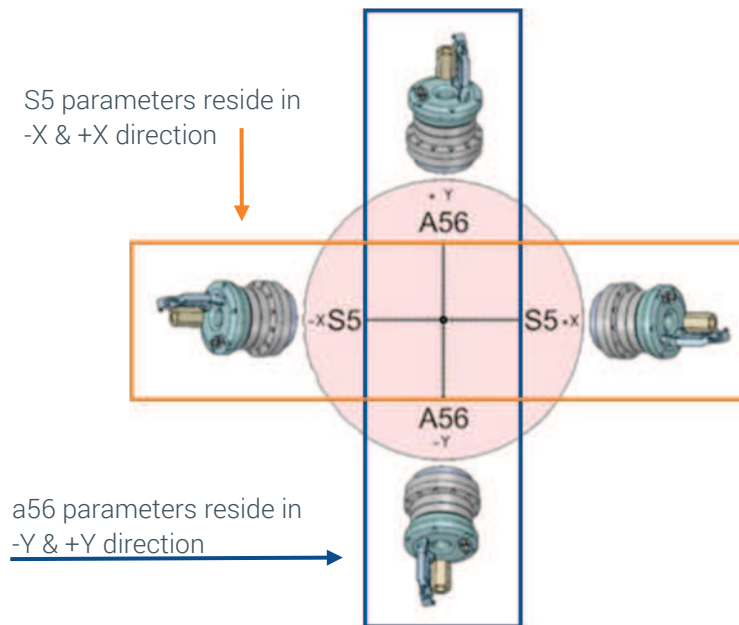

1. On the **5. Displacement parameters adjustment** tab, click **Move to start position** to align the mixing tube with the axis of Motor C. Motor B will point to the left when viewed from the front of the catcher tank.
2. Locate the gauge to the left of the mixing tube (as viewed from the front) with the chisel point on the mixing tube. Ensure there is enough clearance between the Motor B bracket and the dial gauge so they do not collide while moving.

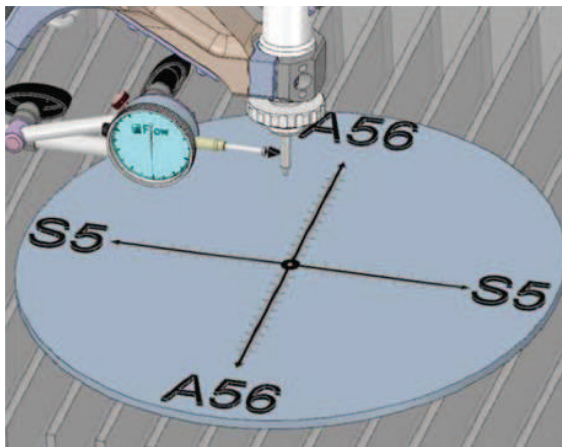

3. Click **Start Compensated move**. Motor C will rotate using previously collected data.
4. Look at the dial gauge and record the indicator readings when Motor B is in the maximum position for:
 - Front (-Y)
 - Right (+X)
 - Back (+Y)
 - Left (-X)

Make sure to record whether the movement is a positive or negative value. Note that Motor C will travel several degrees past the start position.

5. Click **Send motor-C home** to unwind the cutting head. Since the return move is uncompensated, the overall motion of the dial gauge shows the true uncompensated position of the mixing tube.
6. In the **S5** box, adjust the value based on the change in S5.

$$\text{Change in S5} \approx 0.58 \times (\text{Right} - \text{Left})$$

7. In the **a56** box, adjust the value based on the change in a56.

$$\text{Change in a56} \approx 0.5 \times (\text{Back} - \text{Front})$$

8. Repeat Steps 3–7 until overall deflection is less than 0.001 in. while Motor B crosses the S5 and a56 locations.
9. Click **RESET B & C motors**, and then click **OK** when you receive the “Please restart FlowCUT and home motors B and C” message.

Motor B, Motor C, and the Z-axis are sent to home position. Motors B and C are reset to account for the unique physical structure of the wrist.

10. Exit the DynAlign Calibration Utility.

11. Start FlowCUT, and then click **Run Machine**

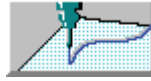

12. Click **Home z-axis** , and then click **Yes** when you receive the message.

Now FlowCUT will use the new calibration values and the machine is ready to resume cutting.

Prepare the machine to cut parts

1. Remove tools and supplies from X-Y table.
2. Install the pierce shield.

Do you have a Compass?

Remember to install the mixing tube spacer. In FlowCUT, clear the **Enable Height Sensor** check box.

3. Tighten the gland nut on the on/off valve.
4. Turn on the water supply.

Cut a trapezoid part for final adjustment

The design of the Dynamic XD wrist removes mechanisms normally used to adjust the focal point of the assembly. Without these hardware adjustments, you must also calibrate the wrist using software. By mathematically describing the physical arrangement of the wrist hardware, the motion program is adjusted so the wrist acts as if the focal point is mechanically maintained.

Note that the calibration performed by the DynAlign Calibration Utility does not calculate all of the DH parameters. Specifically, the methods used by the calibration utility cannot capture any small changes in the actual tool length of the wrist.

1. Cut a trapezoidal shaped part with 1.5 inch thick aluminum.
2. Measure the top width of the vertical part and verify it is 0.75 inches.

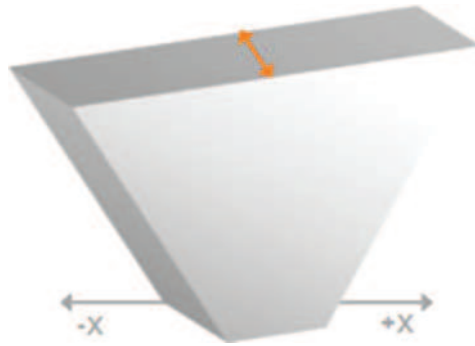

In the **Setup** screen, adjust the **Tool radius**.
Repeat cutting the part until the width is correct.

3. Measure the top length of the vertical part and verify it is 2.5 inches.

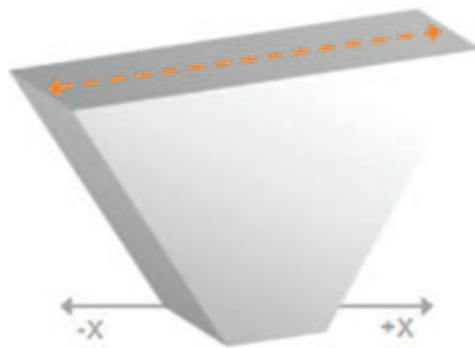

If it's too long, decrease the tool length.
If it's too short, increase the tool length.
Repeat cutting the part until the length is correct.

4. Inspect the part for other issues. The finish of the part should be smooth except for slight marks where Motor C rotates rapidly at wrist singularity points. Slightly visible marks at these points are acceptable.

If there are no issues, calibration is complete.

FAQ

What is the definition of “minimum motion?”

Minimum motion: less than 0.001 in. of motion.

Where’s the trapezoid part file?

Find the part file at:

C:\Program Files (x86)\Flow International\FlowCUT 7\ Calibration\Trapezoid.ord

What is “starting point?”

Starting point: the left-most adjustment screw on the Y-gate of the DynAlign station.

How do I figure the amount I need to adjust the tool length by?

A difference of 0.0013 inches in the length of the part corresponds to a change of 0.001 inches in the tool length.

EXAMPLE (in inches)

2.50 (programmed length) – 2.435 (actual length) = 0.065 (error)

0.065 (error) ÷ 1.3 (correction factor) = 0.05 (amount to increase the tool length by)

How do I adjust the tool length?

1. In the **Setup** screen, on the **Setup** menu, point to **Dynamic waterjet**, and then click **Dynamic Waterjet setup**.
2. In the **Dynamic Waterjet Setup** dialog box, type a value in the **Tool length** box, and then click **OK**.

3. Click **Run Machine**  and cut the part again.

Clean the diamond orifice & nozzle nut

Clean the diamond orifice and nozzle nut every 250 hours or any time you experience degraded waterjet quality.

Prep for success

TOOLS & SUPPLIES

- Clean, lint-free cloth
- Detergent/cleaning agent (Fisher Scientific, FL-70 alkaline detergent, #SF105-1)
- Distilled water
- Isopropyl alcohol
- Plastic forceps (Fisher Scientific #10-309)
- Three 100 ml graduated polypropylene beakers (Fisher Scientific #02-591-10B)
- Two 1-liter bottles with airtight, nonmetallic caps
- Ultrasonic cleaner, 70-80 kHz frequency

GOOD TO KNOW!

- We recommend that you put your parts in beakers instead of directly into the ultrasonic cleaner. Why? Parts have to cycle through three different solutions during the cleaning process. By using beakers, you'll save time and use less solvent!

Mix the cleaning solution

1. Pour 720 ml of distilled or de-ionized water into a 1-liter bottle, and then slowly add 80 ml of isopropyl alcohol to make a 10% solution.
2. Cap the bottle, swirl to mix, and then label and date the bottle.
3. Pour 440 ml of distilled into a 1-liter bottle, and then slowly add 440 ml of the FL-70 detergent to make a 50% solution.
4. Cap the bottle, swirl to mix, and then label and date the bottle.
5. Label the three beakers as follows: 10% isopropyl alcohol, 50% distilled water, Distilled water
6. Pour 50 ml of each solution into their respective beaker.

7. Put the beakers in the ultrasonic cleaner (from left to right) in this order: 10% isopropyl alcohol, 50% distilled water, Distilled water
8. Pour distilled water into the ultrasonic cleaner until it reaches “just below” the 50 ml mark on the beakers.

Clean the parts



CAUTION! Parts are cycled through chemical solutions. Always handle the parts with plastic forceps.

1. Turn on the ultrasonic cleaner.
2. Put the orifice in the beaker of isopropyl alcohol, and then let it soak for five minutes.
3. Move the orifice to the beaker of detergent, and then let it soak for five minutes.
4. Move the orifice to the beaker of distilled water, and then let it soak for five minutes.
5. Remove the orifice from the beaker, set it on a clean, lint-free cloth, and then let it air dry.
6. Examine the orifice to make sure it did not dislodge from its mount during cleaning. Ensure all parts are clean and free of debris or abrasive.
7. Store the orifice in a clean container.
8. Repeat steps 1–7 for the nozzle nuts.

Replace the diamond orifice

Replace the diamond orifice after every 1000 hours of operation.

TOOLS & SUPPLIES

- Blue Lubricant
- Torque wrench with crows foot attachment

TASK

1. Make sure the high-pressure pump is off and bleed down all pressure from the system.
2. Pull firmly on the abrasive feed line to remove it from the cutting head.
3. Open the cutting head clamp.
4. Using a 1-1/8 in. wrench on the mixing chamber and a 7/8 in. wrench on the nozzle body, separate the mixing chamber and nozzle body.
5. Tap the mixing chamber upside down on a table to remove the orifice assembly. If necessary, lightly pry on the mount with a screwdriver.
6. Clean the mixing chamber to remove any abrasive or debris.
7. Inspect the carbide insert inside the mixing chamber. Replace the mixing chamber if you find the following:
 - Evidence of erosion, wear, or other damage such as pitting
 - Hole is oblong shape instead of round
 - Hole diameter is larger than 1.8 mm (0.07 in.)

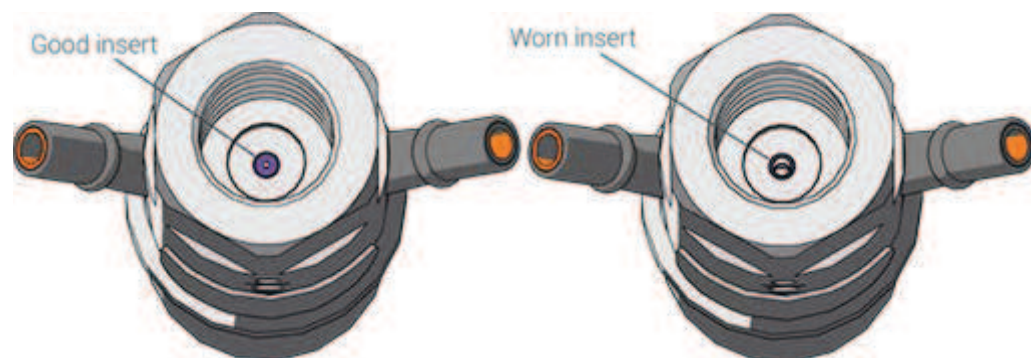

8. Apply a thin layer of BLUE LUBRICANT on the angled surface of the orifice assembly. Use a clean, lint-free applicator such as a small paintbrush to do this.

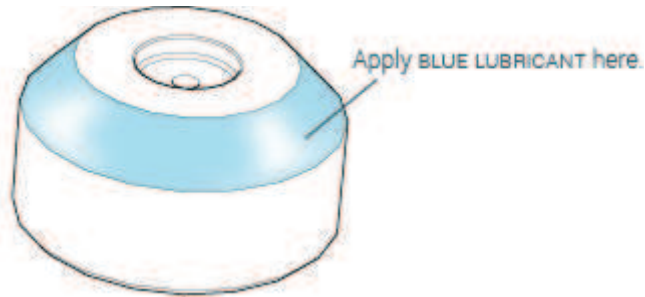

9. Make sure the seating surface in the mixing chamber is free of abrasive and debris, and then drop the orifice assembly—flat face down, taper side up— into the recess of the body.
10. Apply BLUE LUBRICANT to the threads of the nozzle body. Attach the mixing chamber body to the nozzle body and then tighten to 41–48 N·m (30–35 ft·lb).

NOTICE Do not over-tighten the cutting head—it will damage mating surfaces and the orifice mount. Such damage is not covered by warranty.

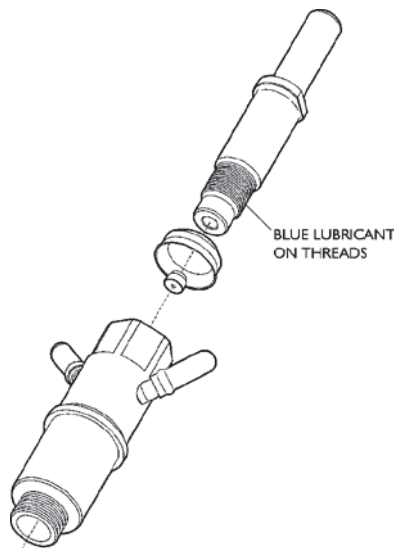

11. Clean the top surface of the cutting head clamp with a clean, lint-free cloth to remove any abrasive or debris.
12. Place the cutting head assembly in the clamp. Before you close the clamp, make sure the flat on the cutting head sits flush with the top of the clamp.
13. Attach the abrasive feed line.

Troubleshooting

Troubleshooting with FlowSENSE

Dynamic Waterjet

DESCRIPTION	ITEM	COMMENTS
System: Axis fault code	niAxis_Fault_Code	1 = Amplifier fault, 2 = Fatal following error
System: Faulted axis indication	niFaulted_Axis	Due to either amp fault or following error, axis has faulted: 1 = X-axis 2 = Y-axis 3 = V-axis 4 = Z-axis 5 = A-axis 6 = B-axis
System: Machine error code	niMachine_Error_Code	1: ABT1 empty 2: ABT2 empty 3: Pump error 6: Amp fault 7: Following error 8: Runtime error 9: EtherCAT error 10: Gantry skew error 11: Height setting error 13: Soft limit 14: E-stop error 15: Light curtain error
System: Abrasive Bulk Transfer Empty Shutdown	P394	
System: Abrasive Bulk Transfer Low Warning	P395	

DESCRIPTION	ITEM	COMMENTS
X Axis Amplifier Error code	M901	710 (1808): Fast overload 720 (1824): Constant overload 810 (2064): Encoder power loss 910 (2320): Overload warning A11 (2577): EtherCAT state error A12 (2578): EtherCAT sync error C90 (3216): Encoder comm. error F10 (3856): Supply power error
Y Axis Amplifier Error code	M902	710 (1808): Fast overload 720 (1824): Constant overload 810 (2064): Encoder power loss 910 (2320): Overload warning A11 (2577): EtherCAT state error A12 (2578): EtherCAT sync error C90 (3216): Encoder comm. error F10 (3856): Supply power error
V Axis Amplifier Error code	M903	710 (1808): Fast overload 720 (1824): Constant overload 810 (2064): Encoder power loss 910 (2320): Overload warning A11 (2577): EtherCAT state error

DESCRIPTION	ITEM	COMMENTS
		A12 (2578): EtherCAT sync error C90 (3216): Encoder comm. error F10 (3856): Supply power error
Z Axis Amplifier Error code	M904	710 (1808): Fast overload 720 (1824): Constant overload 810 (2064): Encoder power loss 910 (2320): Overload warning A11 (2577): EtherCAT state error A12 (2578): EtherCAT sync error C90 (3216): Encoder comm. error F10 (3856): Supply power error
A Axis Amplifier Error code	M905	710 (1808): Fast overload 720 (1824): Constant overload 810 (2064): Encoder power loss 910 (2320): Overload warning A11 (2577): EtherCAT state error A12 (2578): EtherCAT sync error C90 (3216): Encoder comm. error F10 (3856): Supply power error
B Axis Amplifier Error code	M906	710 (1808): Fast overload 720 (1824): Constant overload

DESCRIPTION	ITEM	COMMENTS
		810 (2064): Encoder power loss 910 (2320): Overload warning A11 (2577): EtherCAT state error A12 (2578): EtherCAT sync error C90 (3216): Encoder comm. error F10 (3856): Supply power error
X Axis Amplifier status	niAmp_Status_1	1: Not ready to switch on 2: Switch on disabled 3: Ready to switch on 4: Switched on 5: Operation enabled 6: Quick stop active 7: Fault reaction active 8: Fault 9: Main power is on 10: Warning has occurred
Y Axis Amplifier status	niAmp_Status_2	1: Not ready to switch on 2: Switch on disabled 3: Ready to switch on 4: Switched on 5: Operation enabled 6: Quick stop active 7: Fault reaction active 8: Fault 9: Main power is on 10: Warning has occurred
V Axis Amplifier status	niAmp_Status_3	1: Not ready to switch on 2: Switch on disabled 3: Ready to switch on 4: Switched on 5: Operation enabled 6: Quick stop active

DESCRIPTION	ITEM	COMMENTS
		7: Fault reaction active 8: Fault 9: Main power is on 10: Warning has occurred
Z Axis Amplifier status	niAmp_Status_4	1: Not ready to switch on 2: Switch on disabled 3: Ready to switch on 4: Switched on 5: Operation enabled 6: Quick stop active 7: Fault reaction active 8: Fault 9: Main power is on 10: Warning has occurred
A Axis Amplifier status	niAmp_Status_5	1: Not ready to switch on 2: Switch on disabled 3: Ready to switch on 4: Switched on 5: Operation enabled 6: Quick stop active 7: Fault reaction active 8: Fault 9: Main power is on 10: Warning has occurred
B Axis Amplifier status	niAmp_Status_6	1: Not ready to switch on 2: Switch on disabled 3: Ready to switch on 4: Switched on 5: Operation enabled 6: Quick stop active 7: Fault reaction active 8: Fault 9: Main power is on 10: Warning has occurred
EtherCAT network error code	ECAT[0].Error	EtherCAT network enabling error code. See separate

DESCRIPTION	ITEM	COMMENTS
		document for further information.
EtherCAT network slave status	ecat_slaves_present	This variable value needs to be converted to binary format to determine which slave is missing.
EtherCAT network master state	ECAT[0].MasterState	EtherCAT network master state: 0: Not active 1: Init 2: PreOp 4: SafeOp 8: Op
X Axis Following Error Warning	M141	
Y Axis Following Error Warning	M241	
Z Axis Following Error Warning	M341	
B Axis Following Error Warning	M541	
C Axis Following Error Warning	M641	
X Axis Positive Hardware Limit	M157	
X Axis Negative Hardware Limit	M158	
Y Axis Positive Hardware Limit	M257	
Y Axis Negative Hardware Limit	M258	
System: Z Axis Too Low	P475	Home Z, A, B axes before attempting to Home X and Y.
Timer not active	P505	Timer (PLC5) is not running. Make sure PLC5 is active.

DESCRIPTION	ITEM	COMMENTS
Emergency Stop	M111	
Nozzle 1 cycle counter	niNozzle_Counter1	
Abrasive on time head 1 in minutes	niAbrasiveOn_Time1	
Pump was left on without jet more than 15 minutes	P999	
TDP sensor signal	M175	Use this to check TDP sensor signal
TDP sensor error	niHS1_Sensor_Error	Error code : 0-No error 1-Signal out of range 2-Signal out of range 3=Sensor signal too low 4=Sensor signal too high 5=Sensor over extended 6=Erroneous sensor signal
Standoff setting device is not selected	P2061	Use Option Components button to select the device : Height Setter or Dynamic Contour Follower
TDP sensor signal fully extended	niHS1_Signal_Extended	TDP sensor signal upper limit (cts.).
TDP sensor calibration point 1.	niHS1_Cal_Point1	
TDP sensor calibration point 2.	niHS1_Cal_Point2	
TDP sensor signal when mixing tube tip is at SOD position.	niHS1_Cal_Signal	Reference sensor signal obtained during TDP sensor calibration routine
Standoff setting device is not selected	P2061	Use Option Components button to select the device : Height Setter or Dynamic Contour Follower
Intensifier Pump: Motor Starter Fault / Motor Overload	P215	

DESCRIPTION	ITEM	COMMENTS
Intensifier Pump: Overpressure	P538	
Intensifier Pump: Inlet Water Pressure Low Warning	P216	The inlet water supply pressure is too low. Check valves, connections and water supply.
Intensifier Pump: Inlet Water Pressure Low Shutdown	P218	The inlet water supply pressure is too low. Check valves, connections and water supply.
Intensifier Pump: Hydraulic Oil Overtemp Shutdown	P226	The hydraulic oil temperature is too high. Check temperature gauge and connections.
Intensifier Pump: Hydraulic Oil Overtemp Warning	P224	The hydraulic oil temperature is too high.
Intensifier Pump: Low Hydraulic Oil Level Shutdown	P228	The hydraulic oil level is too low. Check oil window and connections.
Intensifier Pump: HP Bleeddown Temp. High Warning	P219	The bleeddown valve temperature is too high. Power down the system and check for leakage through valve.
Intensifier Pump:#1 Left Check Valve Overtemp Warning	P220	The intensifier 1 left check valve temperature is too high. Power down the system and check for leakage through valve.
Intensifier Pump:#1 Right Check Valve Overtemp Warning	P221	The intensifier 1 right check valve temperature is too high. Power down the system and check for leakage through valve.
Intensifier Pump: Watchdog Timeout	P232	Change in Watchdog flag from FlowMaster was overdue

DESCRIPTION	ITEM	COMMENTS
Intensifier Pump: Intensifier Over Speed Warning	P195	The Intensifier Pump is shifting faster than 100 times per minute
Intensifier Pump: Intensifier Over Speed Shutdown	P194	The Intensifier Pump was shifting faster than 100 times per minute for over 90 seconds
Intensifier Pump: Oil filter dirty warning	P253	Oil filter is dirty. It needs to be replaced.

DESCRIPTION	ITEM	COMMENTS
System: Axis fault code	niAxis_Fault_Code	1 = Amplifier fault, 2 = Fatal following error
System: Faulted axis indication	niFaulted_Axis	Due to either amp fault or following error, axis has faulted: 1 = X-axis 2 = Y-axis 3 = V-axis 4 = Z-axis 5 = A-axis 6 = B-axis
System: Machine error code	niMachine_Error_Code	1: ABT1 empty 2: ABT2 empty 3: Pump error 6: Amp fault 7: Following error 8: Runtime error 9: EtherCAT error 10: Gantry skew error 11: Height setting error 13: Soft limit 14: E-stop error 15: Light curtain error
System: Abrasive Bulk Transfer Empty Shutdown	P394	
System: Abrasive Bulk Transfer Low Warning	P395	
System: XD Safety Limit Positive Warning	Q7239	0. Limit not exceeded (Normal) 1. Jet outside default safety range in X + 2. Jet outside default safety range in Y +

DESCRIPTION	ITEM	COMMENTS
		If this value is not 0, the program would not complete with the default safety range settings.
System: XD Safety Limit Positive Shutdown	Q7238	0. Safety limit not exceeded (Normal) 1. Safety limit exceeded in X + 2. Safety limit exceeded in Y +
System: XD Safety Limit Negative Shutdown	Q7238	0. Safety limit not exceeded (Normal) -1. Safety limit exceeded in X - -2. Safety limit exceeded in Y -
X Axis Amplifier Error code	M901	710 (1808): Fast overload 720 (1824): Constant overload 810 (2064): Encoder power loss 910 (2320): Overload warning A11 (2577): EtherCAT state error A12 (2578): EtherCAT sync error C90 (3216): Encoder comm. error F10 (3856): Supply power error
Y Axis Amplifier Error code	M902	710 (1808): Fast overload 720 (1824): Constant overload

DESCRIPTION	ITEM	COMMENTS
		810 (2064): Encoder power loss 910 (2320): Overload warning A11 (2577): EtherCAT state error A12 (2578): EtherCAT sync error C90 (3216): Encoder comm. error F10 (3856): Supply power error
V Axis Amplifier Error code	M903	710 (1808): Fast overload 720 (1824): Constant overload 810 (2064): Encoder power loss 910 (2320): Overload warning A11 (2577): EtherCAT state error A12 (2578): EtherCAT sync error C90 (3216): Encoder comm. error F10 (3856): Supply power error
Z Axis Amplifier Error code	M904	710 (1808): Fast overload 720 (1824): Constant overload 810 (2064): Encoder power loss 910 (2320): Overload warning A11 (2577): EtherCAT state error A12 (2578): EtherCAT sync error C90 (3216): Encoder comm. error

DESCRIPTION	ITEM	COMMENTS
		F10 (3856): Supply power error
A Axis Amplifier Error code	M905	710 (1808): Fast overload 720 (1824): Constant overload 810 (2064): Encoder power loss 910 (2320): Overload warning A11 (2577): EtherCAT state error A12 (2578): EtherCAT sync error C90 (3216): Encoder comm. error F10 (3856): Supply power error
B Axis Amplifier Error code	M906	710 (1808): Fast overload 720 (1824): Constant overload 810 (2064): Encoder power loss 910 (2320): Overload warning A11 (2577): EtherCAT state error A12 (2578): EtherCAT sync error C90 (3216): Encoder comm. error F10 (3856): Supply power error
X Axis Amplifier status	niAmp_Status_1	1: Not ready to switch on 2: Switch on disabled 3: Ready to switch on 4: Switched on 5: Operation enabled 6: Quick stop active 7: Fault reaction active

DESCRIPTION	ITEM	COMMENTS
		8: Fault 9: Main power is on 10: Warning has occurred
Y Axis Amplifier status	niAmp_Status_2	1: Not ready to switch on 2: Switch on disabled 3: Ready to switch on 4: Switched on 5: Operation enabled 6: Quick stop active 7: Fault reaction active 8: Fault 9: Main power is on 10: Warning has occurred
V Axis Amplifier status	niAmp_Status_3	1: Not ready to switch on 2: Switch on disabled 3: Ready to switch on 4: Switched on 5: Operation enabled 6: Quick stop active 7: Fault reaction active 8: Fault 9: Main power is on 10: Warning has occurred
Z Axis Amplifier status	niAmp_Status_4	1: Not ready to switch on 2: Switch on disabled 3: Ready to switch on 4: Switched on 5: Operation enabled 6: Quick stop active 7: Fault reaction active 8: Fault 9: Main power is on 10: Warning has occurred
A Axis Amplifier status	niAmp_Status_5	1: Not ready to switch on 2: Switch on disabled 3: Ready to switch on 4: Switched on

DESCRIPTION	ITEM	COMMENTS
		5: Operation enabled 6: Quick stop active 7: Fault reaction active 8: Fault 9: Main power is on 10: Warning has occurred
B Axis Amplifier status	niAmp_Status_6	1: Not ready to switch on 2: Switch on disabled 3: Ready to switch on 4: Switched on 5: Operation enabled 6: Quick stop active 7: Fault reaction active 8: Fault 9: Main power is on 10: Warning has occurred
EtherCAT network error code	ECAT[0].Error	EtherCAT network enabling error code. See separate document for further information.
EtherCAT network slave status	ecat_slaves_present	This variable value needs to be converted to binary format to determine which slave is missing.
EtherCAT network master state	ECAT[0].MasterState	EtherCAT network master state: 0: Not active 1: Init 2: PreOp 4: SafeOp 8: Op
X Axis Following Error Warning	M141	
Y Axis Following Error Warning	M241	
Z Axis Following Error Warning	M341	

DESCRIPTION	ITEM	COMMENTS
B Axis Following Error Warning	M541	
C Axis Following Error Warning	M641	
X Axis Positive Hardware Limit	M157	
X Axis Negative Hardware Limit	M158	
Y Axis Positive Hardware Limit	M257	
Y Axis Negative Hardware Limit	M258	
System: Z Axis Too Low	P475	Home Z, A, B axes before attempting to Home X and Y.
Timer not active	P505	Timer (PLC5) is not running. Make sure PLC5 is active.
Emergency Stop	M111	
Nozzle 1 cycle counter	niNozzle_Counter1	
Abrasive on time head 1 in minutes	niAbrasiveOn_Time1	
Pump was left on without jet more than 15 minutes	P999	
Compass error code	P22995	Error code : Check the user manual
DynaBeam signal	M84	Use this to check the output from DynaBeam signal
DynaBeam material surface sensing error	P2003	Error code : 0-No error 1-Signal out of range 2-Signal out of range

DESCRIPTION	ITEM	COMMENTS
DynaBeam sensor signal upper limit	P2006	DynaBeam sensor signal upper limit (cts.).
Z1 DynaBeam calibration point 1.	P2007	
Z1 DynaBeam calibration point 2.	P2008	
Z1 DynaBeam Mixing tube tip position.	P2009	
Intensifier Pump: Motor Starter Fault / Motor Overload	P215	
Intensifier Pump: Overpressure	P538	
Intensifier Pump: Inlet Water Pressure Low Warning	P216	The inlet water supply pressure is too low. Check valves, connections and water supply.
Intensifier Pump: Inlet Water Pressure Low Shutdown	P218	The inlet water supply pressure is too low. Check valves, connections and water supply.
Intensifier Pump: Hydraulic Oil Overtemp Shutdown	P226	The hydraulic oil temperature is too high. Check temperature gauge and connections.
Intensifier Pump: Hydraulic Oil Overtemp Warning	P224	The hydraulic oil temperature is too high.
Intensifier Pump: Low Hydraulic Oil Level Shutdown	P228	The hydraulic oil level is too low. Check oil window and connections.
Intensifier Pump: HP Bleeddown Temp. High Warning	P219	The bleeddown valve temperature is too high. Power down the system and check for leakage through valve.
Intensifier Pump:#1 Left Check Valve Overtemp Warning	P220	The intensifier 1 left check valve temperature is too high.

DESCRIPTION	ITEM	COMMENTS
		Power down the system and check for leakage through valve.
Intensifier Pump:#1 Right Check Valve Overtemp Warning	P221	The intensifier 1 right check valve temperature is too high. Power down the system and check for leakage through valve.
Intensifier Pump: Watchdog Timeout	P232	Change in Watchdog flag from FlowMaster was overdue
Intensifier Pump: Intensifier Over Speed Warning	P195	The Intensifier Pump is shifting faster than 100 times per minute
Intensifier Pump: Intensifier Over Speed Shutdown	P194	The Intensifier Pump was shifting faster than 100 times per minute for over 90 seconds
Intensifier Pump: Oil filter dirty warning	P253	Oil filter is dirty. It needs to be replaced.

Troubleshooting the on/off valve

There are two main failure modes for the on/off valve: leaking water (most common) or an on/off valve that does not open or close correctly.

Pay special attention to the utility connections and air lines—the high-pressure water supply could be partially blocked, or there could be bends, holes, or loose connections in the air lines.

On/off valve is leaking

Leak location: High-pressure seal (top)		
Water leaks past the high-pressure seal assembly.		
Drips every few cycles	Seal and back-up ring wear	It's OK to continue to operate the machine, but if the leak causes problems, install the seal kit now. (014988-1)
Steady trickle	Seal and back-up ring wear	Install the seal kit next time the machine is down.
Shooting stream	Failed O-ring or severe seal and back-up ring wear	Install the seal kit immediately.
Leak location: High-pressure inlet		
Water leaks from the tube/valve body.		
Streaming	¼ in. gland is not tight	Turn off the high-pressure pump, and then tighten the ¼ in. gland.
Shooting stream	There is a crack in the high-pressure port of the valve body or tubing.	Replace the valve body or the tubing.
Leak location: Seat		
Water leaks from the valve body or seat, or from the seat or nozzle body interface.		
Streaming	Nozzle body gland is not tight	Turn off the high-pressure pump and then tighten the gland.
Shooting stream	Cracked valve body, seat, or nozzle body	Replace cracked parts.

On/off valve does not open

Low or no air pressure

1. Make sure the shop air supply is on, properly connected, and the pressure is 60-120 psig (4.1-8.3 bar) at the actuator.
2. Turn on the air and listen for leaks in the system. Check for kinks, breaks, and holes in the air line.
3. Check the lights on the solenoid box (on the bridge) to make sure it is switching on and off when commanded.

Lack of high-pressure water

- Make sure the pump is running.
- Check to see that all the hand valves leading to the on/off valve are open.

Partially blocked high-pressure water

1. Turn off the pump and close the hand valve.
2. Disconnect the high-pressure water line from the valve, aim it into the tank, and secure it.
3. Open the hand valve and turn the high-pressure pump back on.
4. Watch to make sure there is a steady stream of high-pressure water shooting into the tank. If the stream is erratic, there may be a blockage in the lines.

Failed actuator

1. Watch the top of the actuator while manually switching the air on and off with the high-pressure water on. If the air port on top of the actuator does not move up and down, there is a problem with the actuator.
2. Remove the mini-actuator from the air line, valve, and machine. Order a new actuator assembly and return the assembly to Flow for evaluation.

Damaged high-pressure valve seal

- If the air port on top of the actuator moves up and down, but the valve still does not open (and you have already checked for little or no air pressure) there may be a problem with the valve seal. Replace the seal assembly.
- If the on/off valve has been operated while the barb fitting has been continuously leaking, the high-pressure seals may be melted and stuck in the valve body. Replace the seal assembly.

Controller command

- Make sure the controller is signaling the valve to open.

On/off valve does not close

Air does not turn off

- Try manually switching the air on and off or disconnecting the air line to see if the valve will close. There may be a problem with your software program or controller command to turn the air off.

Damaged high-pressure valve seal

- If the air port on top of the actuator moves up and down, but the valve still does not open (and you have already checked for little or no air pressure) there may be a problem with the valve seal. Replace the seal assembly.
- If the on/off valve has been operated while the barb fitting has been continuously leaking, the high-pressure seals may be melted and stuck in the valve body. Replace the seal assembly.

Install the on/off valve seal kit

After you troubleshoot the on/off valve, it could seem like you only have to replace one or two parts from the seal kit. However, all seal kit components have similar expected life times. **If one component failed, the others are also likely to fail very soon!** We recommend that you install all seal kit components at the same time to reduce maintenance time and machine downtime.

Standard Waterjet or Dynamic Waterjet

Prep for success

PARTS

- 014988-1, On/off valve seal kit

TOOLS

- 019623-1, Seal installation tool kit
- Crescent wrenches (standard sizes)
- Soft-jaw vise
- Work bench

SUPPLIES

- A-2185, Blue Lubricant
- A-4689, Food grade O-ring Lube (white)

Remove the on/off valve

1. Shut down the system.



WARNING! Shut down the system and bleed all high-pressure from the system. Turn off the high-pressure water and high-pressure water pump.

2. Turn off air to the valve and disconnect the pneumatic line.
3. Disconnect the high-pressure plumbing from the valve body.
4. Open the clamp and remove the entire cutting head assembly, including the valve and actuator. Take the assembly to a clean workbench for any repair procedures.

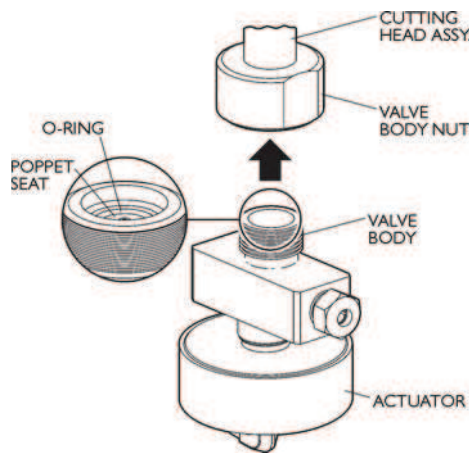

Repair the on/off valve

1. Apply shop air (80 psi min.) to valve actuator assembly to open the valve.
2. Place the assembly in the soft-jaw vise. Unscrew the valve body nut from the valve body. This will separate the valve and actuator from the cutting head and expose the poppet seat.
3. An O-ring helps hold the poppet seat in place. Remove the O-ring, and the poppet seat should fall out of the valve body. Discard the seat and O-ring.
4. If the seat does not fall out when you tap the nozzle body, use the seal installation tool to help loosen the seat.
5. Unscrew the valve body from the actuator assembly. Set the actuator assembly aside.
6. Place the assembly tool (from the tool kit) against the poppet tip and push it out from the valve body.

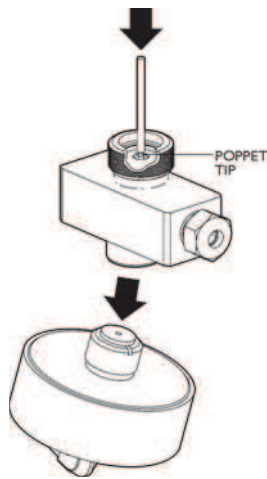

7. The bearing, high-pressure seal, and backup ring should come out with the poppet. If not, push the bearing, seal, and backup ring out of the valve body in the same direction as you pushed the poppet.
8. Discard the poppet, seal, O-ring, and backup ring.
9. Clean any foreign material from the inside and outside of the valve body. Thoroughly clean the valve body, gland, collar, and poppet seat with solvent and dry with shop air.
10. Apply a thin film of white food grade O-ring lube to the new poppet, O-rings, seal, bearing, and backup ring (from the seal kit)
11. Thread the seal guide tool into the valve body.
12. Put together the new seal assembly on the seal installation tool.
 - a. Slide the bearing onto the poppet.
 - b. Place the small high-pressure O-ring on the high-pressure seal.
 - c. Push the seal onto the poppet with the O-ring toward the point of the poppet.
 - d. Slide the backup ring into place against the high-pressure seal.

The seal assembly should be approximately centered on the length of the poppet.

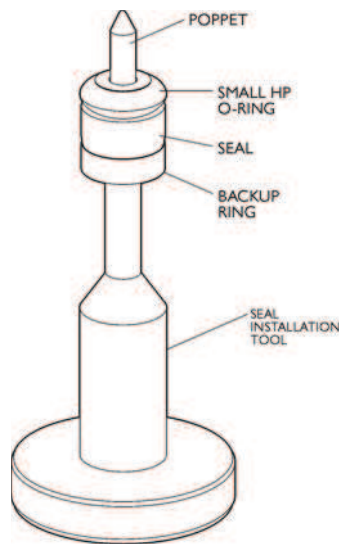

- Slide the poppet seal assembly into the actuator end of the high-pressure valve body, pointed end first.

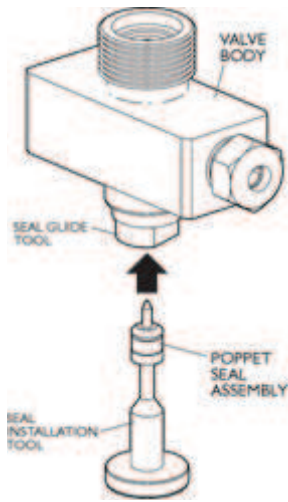

- Apply a thin layer of BLUE LUBRICANT to the threads of the actuator. Reinstall the actuator assembly to the valve body.

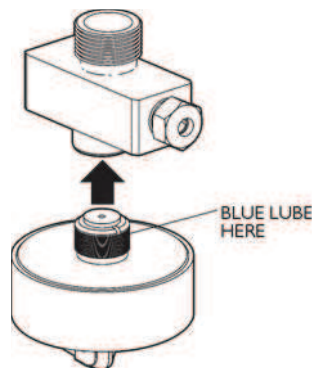

15. Apply a thin layer of BLUE LUBRICANT to both sides of the new poppet seat. Install the poppet seat into the valve body with the small hole facing toward the poppet. Push the O-ring into the groove to hold the poppet seat in place.
16. Apply a thin layer of BLUE LUBRICANT to the external threads of the valve body and thread it onto the nozzle body by tightening the valve body nut. Leave this connection hand tight for now.

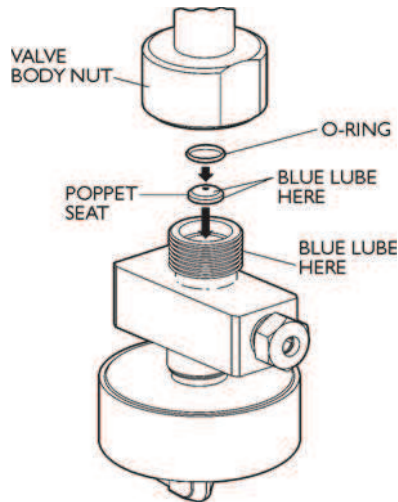

17. Reinstall the cutting head and on/off valve assembly to its original location on the machine by clamping the cutting head in place.

Install the on/off valve

1. Attach the pneumatic control line to the valve actuator assembly and turn on the air (80 psi min.) to open the valve.
2. With the valve in the open position, align the valve with the high-pressure tubing so that the weep tube and high-pressure tubing point toward the front of the machine.
3. Tighten the connection between the nozzle body and the valve body nut to 35–40 ft-lb (47–54 N-m). Once the connection is tight, turn off the air to close the valve.

Opening the valve before tightening this connection reduces the possibility of galling between the poppet and seat interface and reduces the force required as you are not working against the high spring force of the actuator.

4. Attach the high-pressure tubing to the valve. Be careful not to over-torque this connection.

5. Turn on the high-pressure water source and slowly raise the pressure while checking for leaks. Manually actuate the valve a few times to make sure it is operating correctly.

Dynamic XD

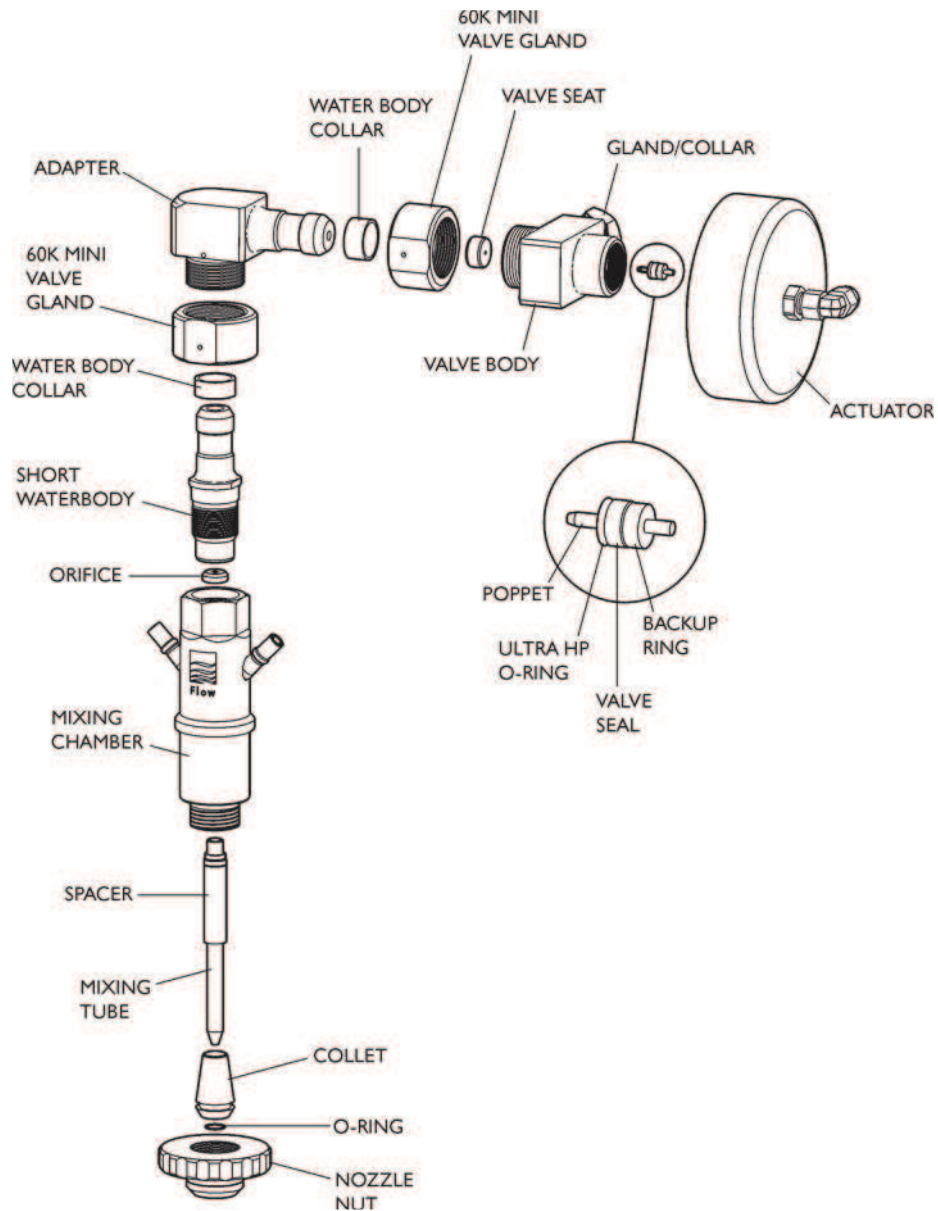

Prep for success

PARTS

- 014988-1, On/off valve seal kit

TOOLS

- 019623-1, Seal installation tool kit
- Crescent wrenches (standard sizes)
- Soft-jaw vise
- Work bench

SUPPLIES

- A-2185, Blue Lubricant
- A-4689, Food grade O-ring Lube (white)

PRECAUTION

- When working on high-pressure components, it is critical that you use backup wrenches. Excessive torque on the cutting head can damage the wrist motors. Such damage will void your warranty.

Remove the on/off valve

1. Shut down the system.



WARNING! Shut down the system and bleed all high-pressure from the system. Turn off the high-pressure water and high-pressure water pump.

2. Open FlowCUT and select **Setup | Dynamic waterjet | Straightness adjustment...** from the Run Machine screen to display the Straightness adjustment dialog box.
3. Rotate the B-motor 45° so the top of the cutting head is facing towards you.
4. Turn off air to the valve and disconnect the pneumatic line.
5. Turn off the high-pressure pump and bleed all pressure from the system
6. Place a tray on the catcher tank under the cutting head to catch any falling parts.
7. At the high-pressure valve body, hold the mini valve gland with a 138 in. wrench, and loosen the high-pressure water gland/collar with a 3/4 in. wrench. Loosen the high-pressure tubing.

Note: Do not rotate the cutting head.

8. Hold the adapter elbow on the cutting head with a 1-3/16 in. wrench and loosen the adjacent mini valve gland with a 1/8 in. wrench under 90°.

Note: Do not rotate the cutting head.

9. Fully unscrew the gland nut from the on/off valve actuator assembly. Rotate the assembly back and out of the way.

Repair the valve

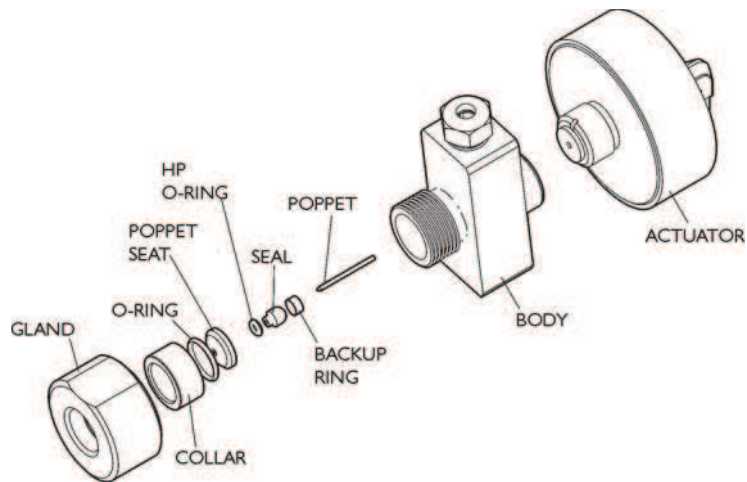

1. Apply shop air (80 psi min.) to the valve actuator assembly to open the valve.
2. Place the assembly in the soft-jaw vise; unscrew the valve body nut from the valve body. This will separate the valve and actuator from the cutting head and expose the poppet seat.

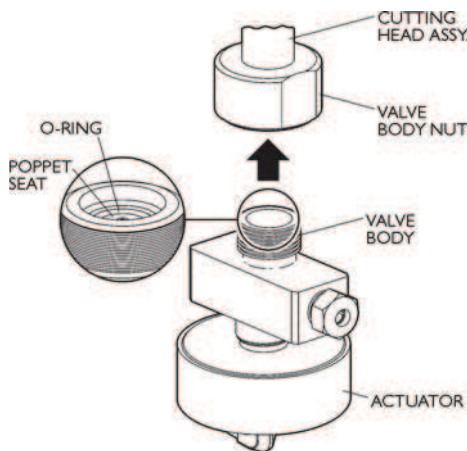

3. An O-ring helps hold the poppet seat in place. Remove the O-ring, and the poppet seat should fall out of the valve body. Discard the seat and O-ring.

Note: If the seat does not fall out when you tap the nozzle body, use the seal installation tool to help loosen the seat.

4. Unscrew the valve body from the actuator assembly. Set the actuator assembly aside.
5. Place the assembly tool (from the tool kit) against the poppet tip and push it out from the valve body.

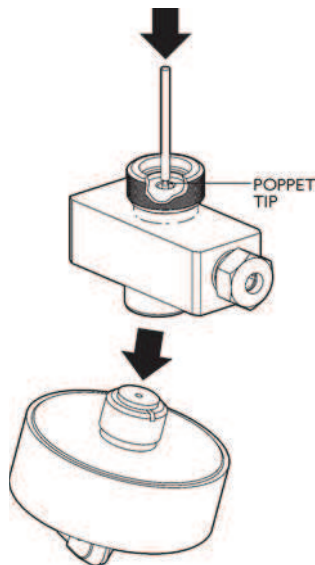

The O-ring, high-pressure seal, and backup ring should come out with the poppet. If not, push these parts out of the valve body in the same direction as you pushed the poppet.

Discard the poppet, seal, O-ring, and backup ring.

6. Clean any foreign material from the inside and out- side of the valve body. Thoroughly clean the valve body, gland, collar, and poppet seat with solvent, then dry with shop air.
7. Apply a thin film of white food grade O-ring lube to the new poppet, O-rings, seal, bearing, and backup ring (from the seal kit).
8. Thread the seal guide tool into the valve body.
9. Put together the new seal assembly on the seal installation tool.
 - a. Slide the backup ring onto the poppet.
 - b. Place the small high-pressure O-ring on the high-pressure seal.
 - c. Push the seal onto the poppet with the O-ring toward the point of the poppet.

The seal assembly should be approximately centered on the length of the poppet.

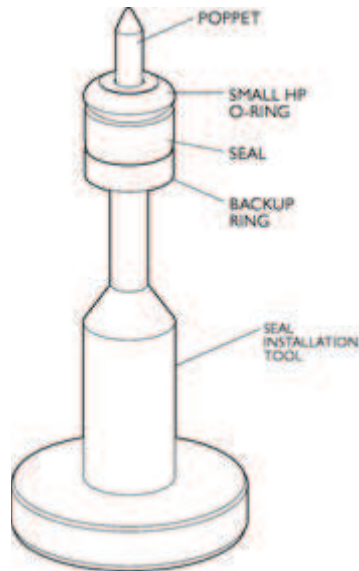

10. Slide the poppet seal assembly into the actuator end of the high-pressure valve body, pointed end first.

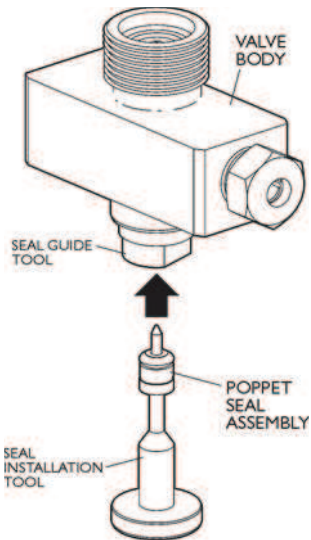

11. Apply a thin layer of BLUE LUBRICANT to the threads of the actuator. Re-install the actuator assembly to the valve body.

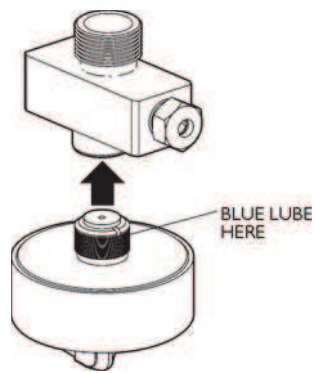

12. Apply a thin layer of BLUE LUBRICANT to both sides of the new poppet seat. Install the poppet seat into the valve body with the small hole facing toward the poppet. Push the O-ring into the groove to hold the poppet seat in place.
13. Apply a thin layer of BLUE LUBRICANT to the external threads of the valve body and thread it onto the nozzle body by tightening the valve body nut. Leave this connection hand-tight for now.

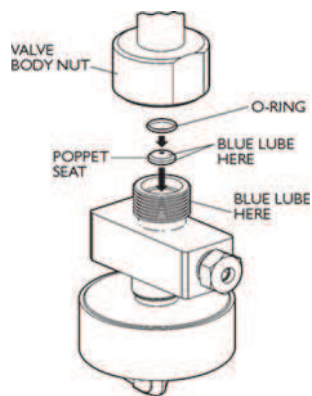

Install the valve

1. Attach the pneumatic control line to the valve actuator assembly and turn the air on (80 psi min.) to open the valve.
2. With the valve in the open position, align the valve with the high-pressure tubing so that the weep tube and high-pressure tubing point toward the front of the machine.
3. Tighten the connection between the nozzle body and the valve body nut to 35–40 ft-lb (47–54 N-m). Once the connection is tight, turn off the air to close the valve.

Opening the valve before tightening this connection reduces the possibility of galling between the poppet and seat interface; it also reduces the force required, since you aren't working against the high spring force of the actuator.

4. Place the on/off valve actuator assembly on the nozzle body. Hold the adapter elbow on the cutting head with a 1-3/16 in. wrench and tighten the adjacent mini valve gland with a 138 in. wrench under 90°.

Note: Do not rotate the cutting head.

5. At the valve body, hold the mini valve gland with a 1-3/8 in. wrench, and tighten the high-pressure water gland/collar with a 3/4 in. wrench.

Note: Do not rotate the cutting head.

6. Turn the pump on to low pressure and check for leaks. If leaks are detected, shutdown the pump and re-tighten the connections.
7. Turn the pump on to high pressure and check for leaks.
8. In FlowCUT, select **Setup | Dynamic waterjet | B and C go to user home.**

References

Service & Support

We've committed ourselves to the success of our customers for over 40 years. As a result, nearly 1 out of every 3 systems built is delivered to repeat customers. We are proud to provide the largest and most highly trained support team, with the experience to ensure your success.

Flow International World Headquarters

23500 64th Avenue South · Kent, Washington 98032 · USA

Tel: 1.800.526.4810

Flow Europe

Gutenbergstrasse 10 · D64330 Weiterstadt · Germany

Tel: +49 (0) 6151 3095-0

Spares & Consumables

Cutting head spare parts

Item	Standard Waterjet	Dynamic Waterjet	Dynamic XD
Blast disk	711933-1	711933-1	048151-1
Collet	A-23161-8	A-23161-8	710806-1
Mixing chamber	041138-2	041138-2	041138-2
Mixing chamber cap	A-11080	A-11080	A-11080
Mixing tube – Premium XX=ID size	014194-XX-40	014194-XX-40	014194-XX-40
Mixing tube – Standard XX=ID size	014214-XX-40	014214-XX-40	014214-XX-40
Mixing tube spacer	712265-1	712265-1	712265-1
Nozzle body	041137-1	041137-1	044837-1
Nozzle nut	711589-1	711589-1	711589-1
Orifice– Diamond XX=size	015849-XX	015849-XX	015849-XX
O-ring	A-15034-1	A-15034-1	A-15034-1
Spray shield	040411-1	040411-1	048149-1
V-ring seal	A-22752-11	A-22752-11	A-22752-11

Miscellaneous

Item	Standard Waterjet	Dynamic Waterjet	Dynamic XD
Coning & threading kit	–	–	B-5077-2
Cutting head assembly Does not include mixing tube or orifice.	041136-1	041136-1	045160-3 includes on/off valve 014660-2
On/off valve	014660-2	014660-2	–
On/off valve seal kit	014988-1	014988-1	014988-1
On/off valve seal kit installation tool	019623-1	019623-1	019623-1
Swivel rebuild kit	–	–	015093-1