

**END BELL/CYLINDER INTERFACE**

-OIL: PINCHED OR FAILED O-RING  
INCORRECTLY TORQUED TIE ROD

**END BELL WEEP HOLE (TOP/BOTTOM)**

-HOT WATER: FAILED HP SEAL  
FAILED HP CYLINDER  
-COLD WATER: FAILED O-RING ON HP SEAL  
-OIL: FAILED OIL SEAL

**END CAP WEEP HOLE**

-HOT WATER: FAILED HP SEAL  
FAILED HP CYLINDER  
-COLD WATER: FAILED CHECK VALVE O-RING  
FAILED O-RING ON HP SEAL

**CHECK VALVE WEEP HOLE**

-HOT WATER: LOOSE OUTLET BODY

**OUTLET BODY WEEP HOLE**

-HOT WATER: LOOSE HP FITTING  
FAILED CONE SEAT ON HP TUBING  
-HOT TO TOUCH: FAILED OUTLET CHECK VALVE

**END CAP/CHECK VALVE INTERFACE**

-COLD WATER: FAILED CHECK VALVE O-RING

**LOW PRESSURE WATER LINES**

-WARM/PULSING TO TOUCH: LEAKING INLET CHECK VALVE

**MANIFOLD/END BELL**

-OIL: FAILED O-RING  
INCORRECTLY TORQUED BOLTS  
END BELLS NOT PROPERLY ALIGNED

**SHIFT SENSOR**

-OIL: FAILED O-RING  
INCORRECTLY TORQUED BOLTS

**SHIFT VALVE/MANIFOLD**

-OIL: FAILED O-RING  
INCORRECTLY TORQUED BOLTS

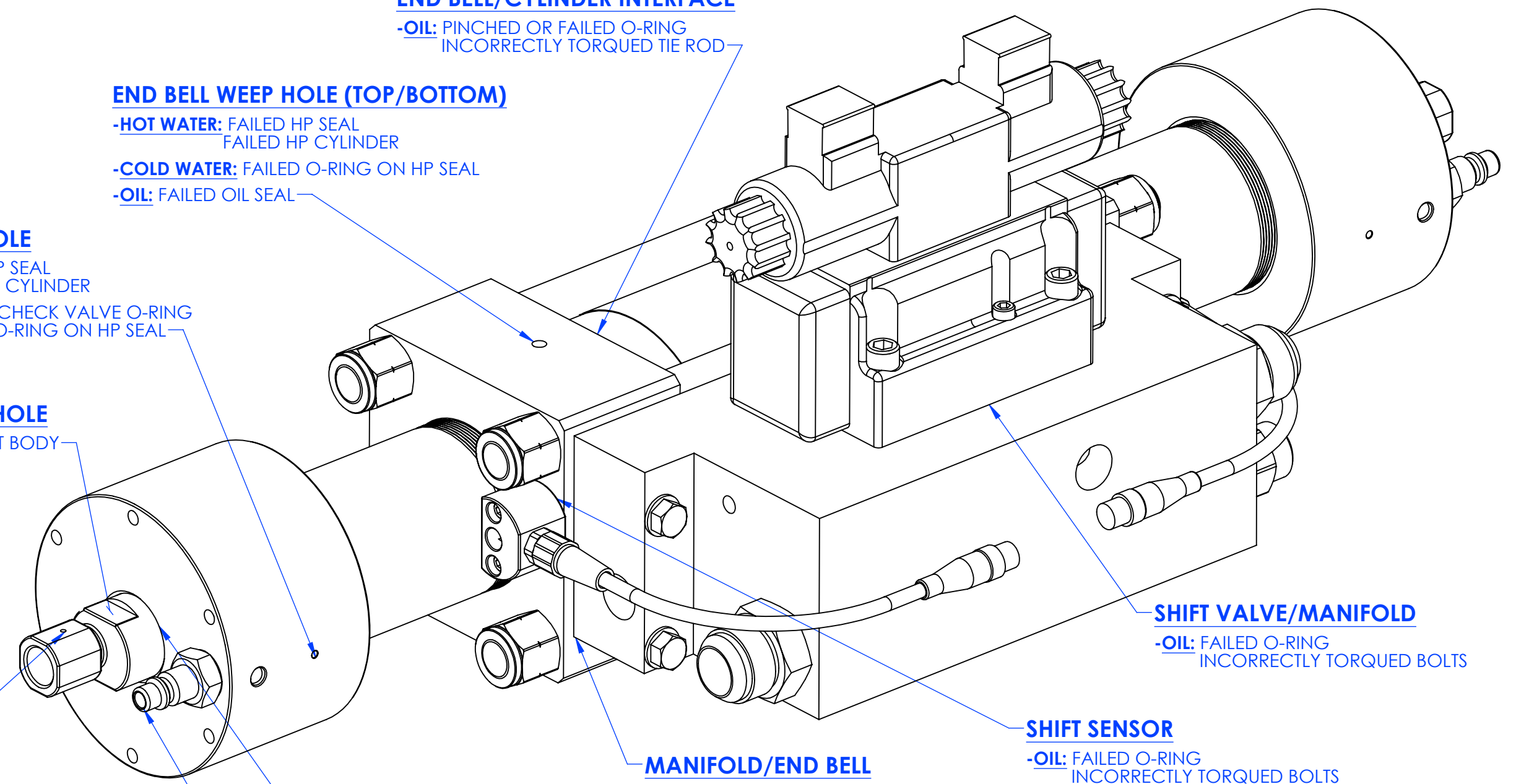

**AHB** Tooling & Machinery, Inc.  
 Complete Metalworking Solutions  
 Roseville Saginaw & Jackson, MI  
 ISO Certified  
 (800) 991-4225  
 www.ahbinc.com  
 customerservice@ahbinc.com

**PROPRIETARY AND CONFIDENTIAL:** THE INFORMATION CONTAINED IN THIS DRAWING IS THE SOLE PROPERTY OF H2O JET INC. ANY REPRODUCTION IN PART OR AS A WHOLE WITHOUT THE WRITTEN PERMISSION OF H2O JET INC. IS PROHIBITED.

<b>H2O JET</b> ™			
DRAWN: M.H.	TITLE: <b>INTENSIFIER WEEP HOLE IDENTIFICATION TROUBLESHOOT GUIDE</b>	REF. NR. -	
CHECKED: H.A.		MADE FROM: -	
APPRVD: H.A.		REV	SHEET
SCALE: NTS	SIZE <b>B</b> DWG. NO. 301020-3-3-HL	0	1 of 1
DATE: 2/10/2011			