

HOT WATER:  
ADAPTER LOOSE  
NOT MAKING SEAL  
ON HP SEAT

COLD WATER:  
O-RING FAILURE  
ON CV BODY

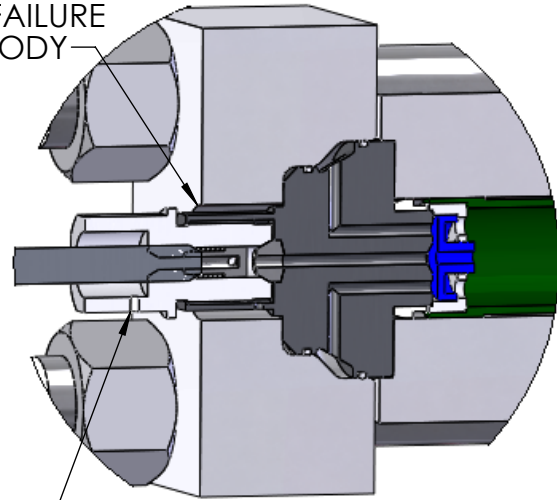

DETAIL C  
SCALE 1 : 2

(FROM WEEP HOLE)  
HOT WATER:  
LOOSE OR DAMAGED  
HP TUBING CONNECTION

HYDRAULIC OIL:  
FAILED OR DAMAGED  
O-RING ON PROX SWITCH

COLD WATER:  
O-RING FAILURE  
CHECK VALVE BODY

HOT WATER:  
FAILED STATIC SEAL  
CRACKED CYLINDER

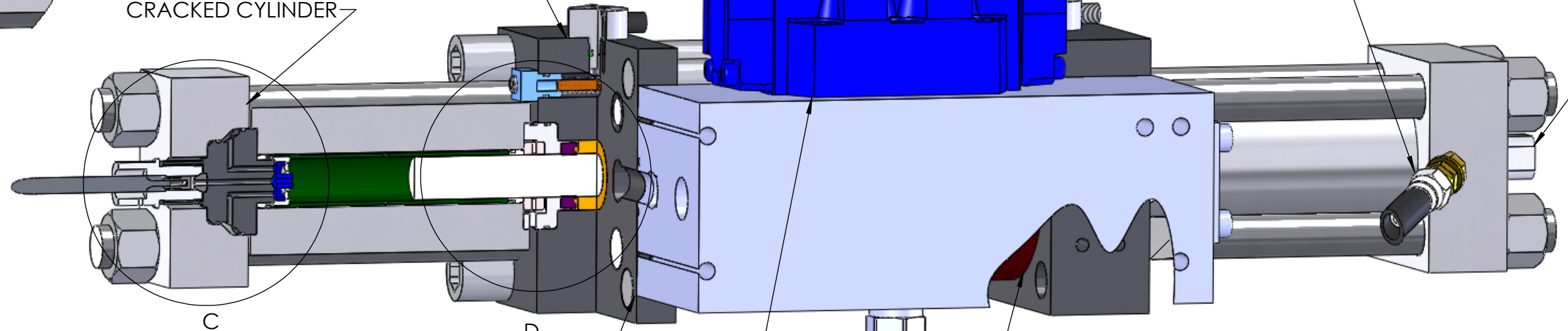

C

D

HYDRAULIC OIL:  
FAILED OR DAMAGED O-RING

HYDRAULIC OIL:  
PINCHED OR FAILED  
O-RING

HYDRAULIC OIL:  
PINCHED OR FAILED  
O-RING

COLD WATER:  
LOOSE FITTING CONNECTION  
WARM FITTING OR PULSING HOSE:  
LOW PRESSURE POPPET LEAK (INTERNAL)

HOT FITTING:  
HP POPPET LEAKING  
CRACKED SEAT  
OR LOOSE ADAPTER

HYDRAULIC OIL:  
IMPROPERLY TORQUED TIE ROD OR  
PINCHED/FAILED O-RING OR BACKUP RING

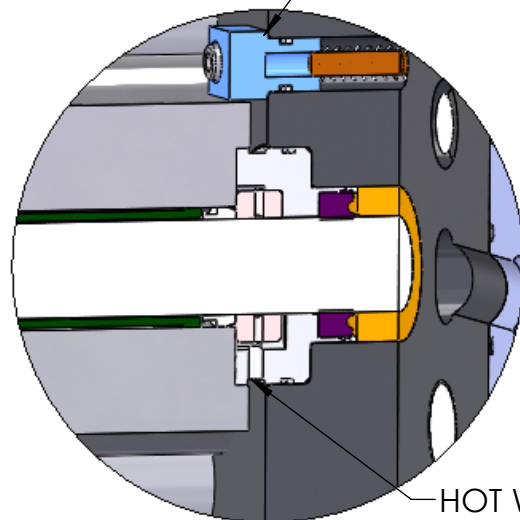

DETAIL D  
SCALE 1 : 2

HOT WATER:  
FAILED DYNAMIC SEAL

HYDRAULIC OIL:  
FAILED ROD SEAL OR  
O-RING AND BACKUP ON  
HYDRAULIC CARTRIDGE

DWG. NO.

11501-GUIDE

SHEET  
1 OF 1

REV  
B

TITLE:

TROUBLESHOOTING GUIDE, HYPRECISION INTENSIFIER

**HIGHLY CONFIDENTIAL  
PROPRIETARY INFORMATION**

ALL DATA AND INFORMATION ON THIS  
DOCUMENT IS FOR THE SOLE USE OF  
ACCUSTREAM AND ITS LICENSEES AND  
MAY NOT BE USED WITHOUT PERMISSION