

HIGHLY CONFIDENTIAL PROPRIETARY INFORMATION				305 2ND ST NW, STE 115 PHONE: 651-294-8600 NEW BRIGHTON, MN 55112 FAX: 651-294-8620 EMAIL: WATERJET@HYPERTHERM.COM WEB: WWW.HYPERTHERM.COM			TITLE: HyPrecisionS 50, 460V, 60HZ ENCLOSURE ASSEMBLY										
				THIS DRAWING AND ALL INFORMATION CONTAINED THEREON IS CONSIDERED PROPRIETARY AND MAY NOT BE USED FOR MANUFACTURING OR FABRICATION PURPOSES WITHOUT PERMISSION FROM HYPERTHERM, INC.	-TOLERANCES- UNLESS OTHERWISE SPECIFIED DIMENSIONS IN INCHES ANGULAR: MACH ± 1 BEND ± 1 ONE PLACE DECIMAL ± .05 TWO PLACE DECIMAL ± .015 THREE PLACE DECIMAL ± .005 BREAK AND DEBURR ALL EDGES .015 MAX	<table border="1"> <tr> <td>NAME</td> <td>DATE</td> <td>MATERIAL</td> </tr> <tr> <td>DRAWN SMM</td> <td>03-26-14</td> <td></td> </tr> <tr> <td>CHECKED XXX</td> <td></td> <td>HARDNESS</td> </tr> <tr> <td>ENG APPR. XXX</td> <td></td> <td>WEIGHT</td> </tr> </table>	NAME	DATE	MATERIAL	DRAWN SMM	03-26-14		CHECKED XXX		HARDNESS	ENG APPR. XXX	
NAME	DATE	MATERIAL															
DRAWN SMM	03-26-14																
CHECKED XXX		HARDNESS															
ENG APPR. XXX		WEIGHT															
			SIZE B	DWG. NO. 14797	REV B												

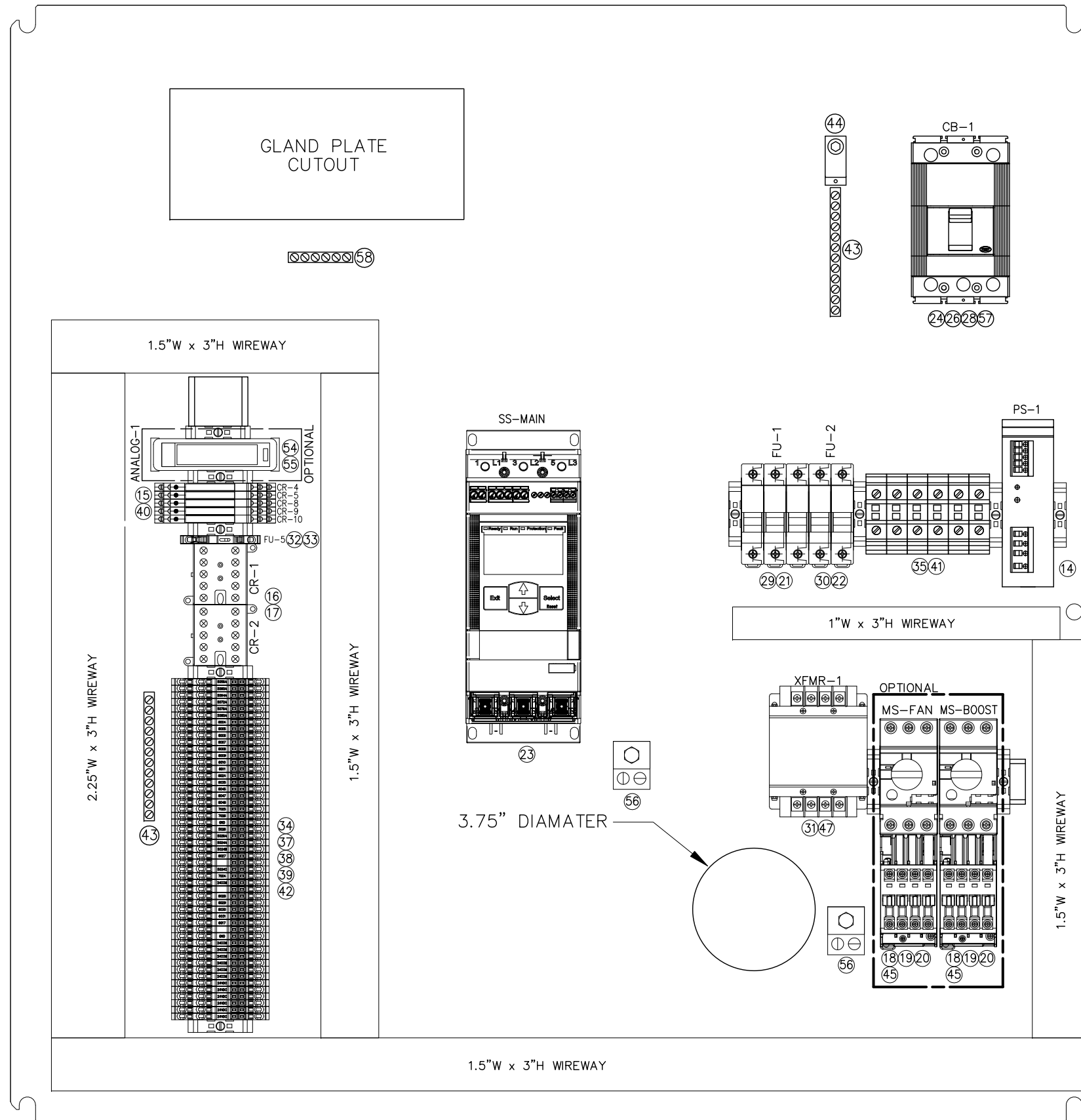



HIGHLY CONFIDENTIAL PROPRIETARY INFORMATION	Hypertherm <small>305 2ND ST NW, STE 115 NEW BRIGHTON, MN 55112 PHONE: 651-294-8600 FAX: 651-294-8620 EMAIL: WATERJET@HYPERTHERM.COM WEB: WWW.HYPERTHERM.COM</small>			TITLE: HyPrecisionS 50, 460V, 60HZ BACK PANEL LAYOUT			
	THIS DRAWING AND ALL INFORMATION CONTAINED THEREON IS CONSIDERED PROPRIETARY AND MAY NOT BE USED FOR MANUFACTURING OR FABRICATION PURPOSES WITHOUT PERMISSION FROM HYPERTHERM, INC.	-TOLERANCES- UNLESS OTHERWISE SPECIFIED DIMENSIONS IN INCHES ANGULAR: MACH ± 1 BEND ± 1 ONE PLACE DECIMAL ± .05 TWO PLACE DECIMAL ± .015 THREE PLACE DECIMAL ± .005 BREAK AND DEBURR ALL EDGES .015 MAX	DRAWN: SMM CHECKED: XXX ENG APPR: XXX	DATE: 03-26-14	MATERIAL: HARDNESS: WEIGHT:	SHEET 2 OF 7	SCALE: 1:1
				SIZE B	DWG. NO. 14797	REV B	

ITEM	QTY.	MANUFACTURER	DESCRIPTION	PART NO.
1	1	RITTAL	ENCLOSURE	WM363612NC
2	1	HORNER ELECTRIC	PLC/OPERTOR INTERFACE	HE-XC1E4
3	1	PATLITE	STACK LIGHT	LME-302-RYG
4	1	ABB	CONTROL POWER ON LIGHT OPERATOR, MOMENTARY, EXTENED, WHITE	MP3-11W
5	1	ABB	HOLDER AND CONTACT BLOCK, 1 N.O.	MCBH-101
6	1	ABB	LED, 24VDC, WHITE	KA2-2025
7	1	IDEC	REMOTE/LOCAL SELECTOR SWITCH OPERATOR, KEYED	HW1K-2A
8	1	IDEC	HOLDER AND CONTACT BLOCK, 1 N.O., 1 N.C.	HW-CBF11
9	1	ABB	E-STOP OPERATOR, MAINTAINED, TWIST TO RELEASE	MPMT3-10R
10	1	ABB	HOLDER AND CONTACT BLOCK, 2 N.C.	MCBH-02
11	1	ABB	REMOTE ACTIVE INDICATOR LIGHT, 24VDC, LED, BLUE	CL-502L
12	1	HYPERSTREAM	PLC/OPERATOR INTERFACE MOUNTING PLATE	HYPERTHERM
13	1	HYPERSTREAM	HYPERSTREAM OPERATOR FACEPLATE	HYPERTHERM
14	1	PHOENIX CONTACT	POWER SUPPLY, TRIO, 5 AMP, 24VDC, THREE PHASE	2866462
15	5	PHOENIX CONTACT	SOLID STATE RELAY, 24VDC COIL, SPDT	2966634
16	2	ABB	MINI CONTACTOR, 24VDC COIL, 4 POLE N.O.	BC6-30-10-01
17	2	ABB	SURGE SUPPRESSOR	RV-BC6/60
18	1	ABB	CONTACTOR MATING CONNECTOR	BEA16-4
19	1	ABB	CONTACTOR, 24VDC COIL, 3 POLE 1 N.O. AUX.	AF09Z-30-10-21
20	1	ABB	MANUAL MOTOR PROTECTOR	MS-132-1.0
21	*4	FERRAZ	FUSE, 600V, TIME DELAY, 6 AMP, CLASS CC	ATQR-6
22	*3	FERRAZ	FUSE, 600V, TIME DELAY, .3 AMP, CLASS CC	ATQR-3/10
23	1	ABB	SOFT STARTER	PSE105-600-70
24	1	ABB	CIRCUIT BREAKER, 3 POLE, 80 AMP	T1NQ080TL
25	N/A			
26	1	ABB	ROTARY HANDLE MECHANISM	KT3VD-M
27	1	ABB	ROTARY HANDLE	OHB65J6
28	1	ABB	SHAFT	OSP6X430
29	1	FERRAZ	FUSE HOLDER, 3 POLE, CLASS CC, LIGHTED	USCC3I
30	1	FERRAZ	FUSE HOLDER, 2 POLE, CLASS CC, LIGHTED	USCC2I
31	1	SOLA/HD	TRANSFORMER 460/230V-120V, 50VA	E050
32	1	PHOENIX CONTACT	FUSE HOLDER, 1 POLE, 24VDC LIGHTED, 1 1/4 x 1/4 FUSE	3038765
33	*2	FERRAZ	FUSE, 250V 2 AMP, FAST ACTING, CERAMIC 1 1/4 x 1/4	GAB-2
34	49	PHOENIX CONTACT	TERMINAL BLOCK, SPRING CAGE	3209549
35	6	PHOENIX CONTACT	TERMINAL BLOCK, SCREW, UT 35	3044225
36	N/A			
37	1	PHOENIX CONTACT	TERMINAL BLOCK, END PLATE	3030488
38	11	PHOENIX CONTACT	TERMINAL BLOCK, END BARRIER	0800886
39	2	PHOENIX CONTACT	TERMINAL BLOCK JUMPER, 10 POSITION	3030213
40	1/2	PHOENIX CONTACT	SOLID STATE RELAY JUMPER, 20 POSITION	2966692
41	3	PHOENIX CONTACT	TERMINAL BLOCK JUMPER, 2 POSITION UT 35	3005963
42	2	PHOENIX CONTACT	TERMINAL BLOCK, SPRING CAGE, GROUND	3209565
43	2	SIEMENS	10 HOLE GROUND BAR	ECGB10
44	1	T&B-BLACKBURN	GROUND LUG	ADR21
45	1	ABB	POWER FEED TERMINAL	S1-M3-25
46	1	PATLITE	STACK LIGHT SHAFT	LME-SHAFT2
47	1	SOLA/HD	TRANSFORMER TERMINAL COVERS	IP20
48	1	PHOENIX CONTACT	RJ45 ADAPTOR	1689064
49	1	PHOENIX CONTACT	RJ45 FRAME	1689844
50	1	PHOENIX CONTACT	FRAME CAP	1652606
51	1	BELKIN	ETHERNET CABLE, 7FT.	A3L781-07BL
52	4	HAMMOND	HOLE PLUG, 1.22" DIA.	HP22
53	1	HAMMOND	HOLE PLUG, 2.25" DIA.	HP125
56	2	T&B-BLACKBURN	DOUBLE GROUND LUG	ADR11-21
57	1	ABB	BREAKER LOCKOUT KIT	KT3RHL3
58	1	SIEMENS	5 HOLE GROUND BAR	ECGB5
59	1	RITTAL	PRINT POCKET	2514000

SHIP ONE LOOSE AS SPARE
SHIP ONE LOOSE AS SPARE

PROPORTIONAL PRESSURE CONTROL OPTION				
ITEM	QTY.	MANUFACTURER	DESCRIPTION	PART NO.
54	1	HORNER ELECTRIC	PLC SMARTMOD 2 CHANNEL ANALOG OUTPUT MODULE	HE-359DAC007
55	1	HORNER ELECTRIC	PLC TO SMARTMOD INTERFACE CABLE	TPCCBL

AIR COOLED HEAT EXCHANGER OPTION				
ITEM	QTY.	MANUFACTURER	DESCRIPTION	PART NO.
18	1	ABB	CONTACTOR MATING CONNECTOR	BEA16-4
19	1	ABB	CONTACTOR, 24VDC COIL, 3 POLE 1 N.O. AUX.	AF09Z-30-10-21
20	1	ABB	MANUAL MOTOR PROTECTOR	MS-132-1.0
45	1	ABB	POWER FEED TERMINAL	S1-M3-25

HIGHLY CONFIDENTIAL PROPRIETARY INFORMATION	 <small>305 2ND ST NW, STE 115 NEW BRIGHTON, MN 55112 PHONE: 651-294-8600 FAX: 651-294-8620 EMAIL: WATERJET@HYPERTHERM.COM WEB: WWW.HYPERTHERM.COM</small>			TITLE: HyPrecisionS 50, 460V, 60HZ				
				BILL OF MATERIALS				
<small>THIS DRAWING AND ALL INFORMATION CONTAINED THEREON IS CONSIDERED PROPRIETARY AND MAY NOT BE USED FOR MANUFACTURING OR FABRICATION PURPOSES WITHOUT PERMISSION FROM HYPERTHERM, INC.</small>	-TOLERANCES- UNLESS OTHERWISE SPECIFIED DIMENSIONS IN INCHES		NAME	DATE	MATERIAL	SHEET 3 OF 7	SCALE: 1:1	FINISH
	DRAWN	SMM	03-26-14					
	<small>ANGULAR: MACH ± 1 BEND ± 1 ONE PLACE DECIMAL ± .05 TWO PLACE DECIMAL ± .015 THREE PLACE DECIMAL ± .005 BREAK AND DEBURR ALL EDGES .015 MAX</small>	CHECKED	XXX			HARDNESS		
 	ENG APPR.	XXX			WEIGHT	SIZE B	DWG. NO. 14797	REV B

* QUANTITIES OF FUSES LISTED INCLUDE SPARES

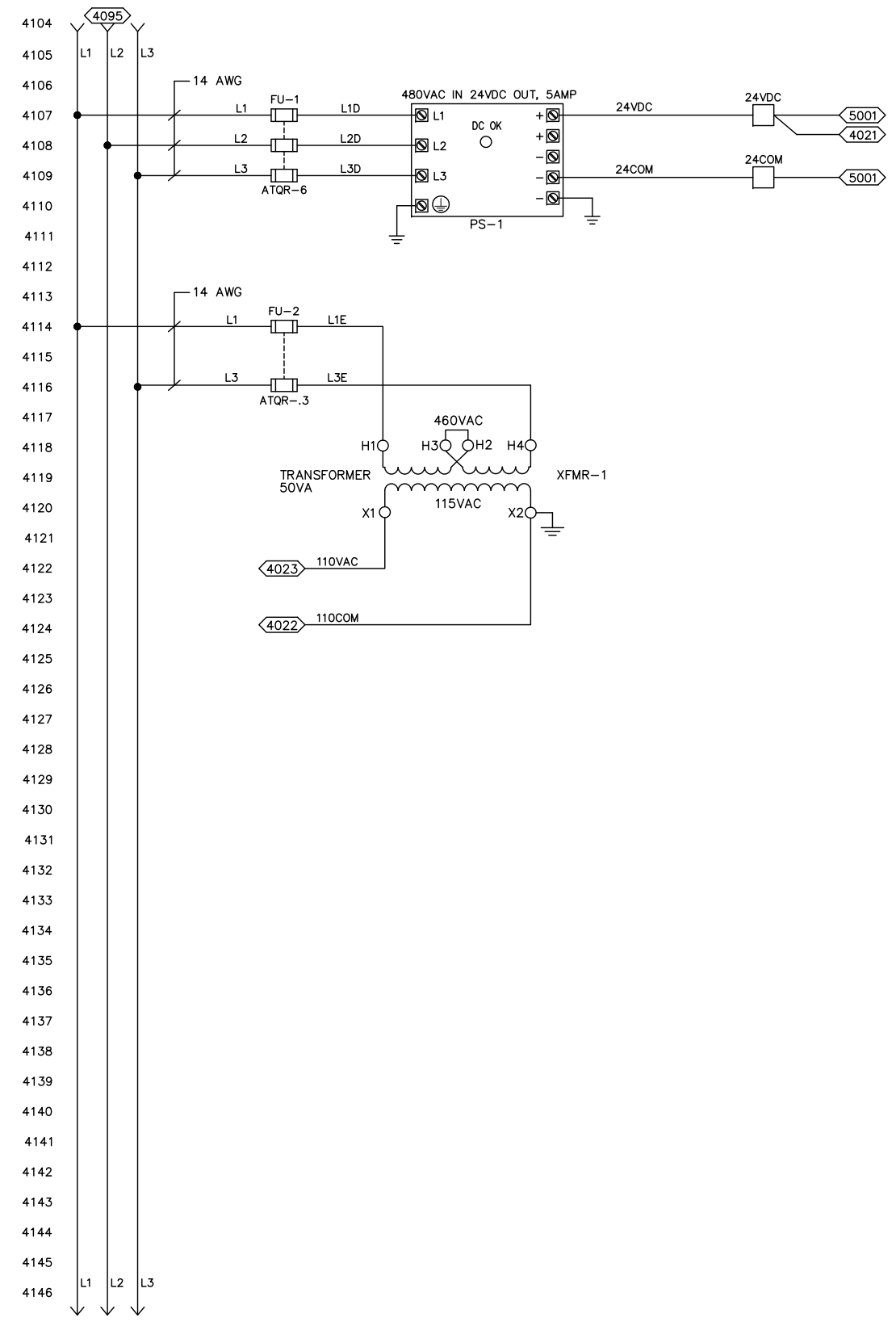
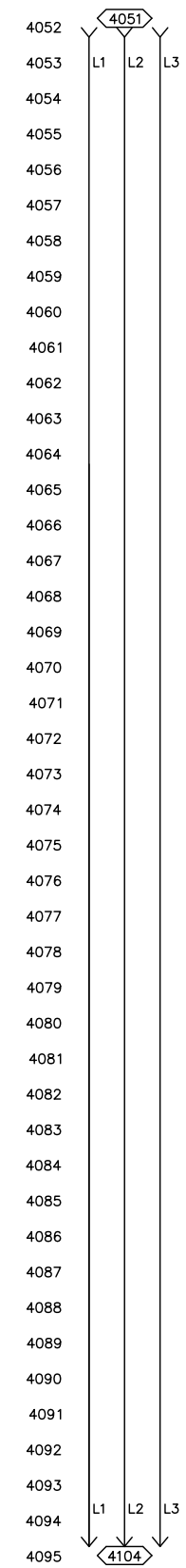
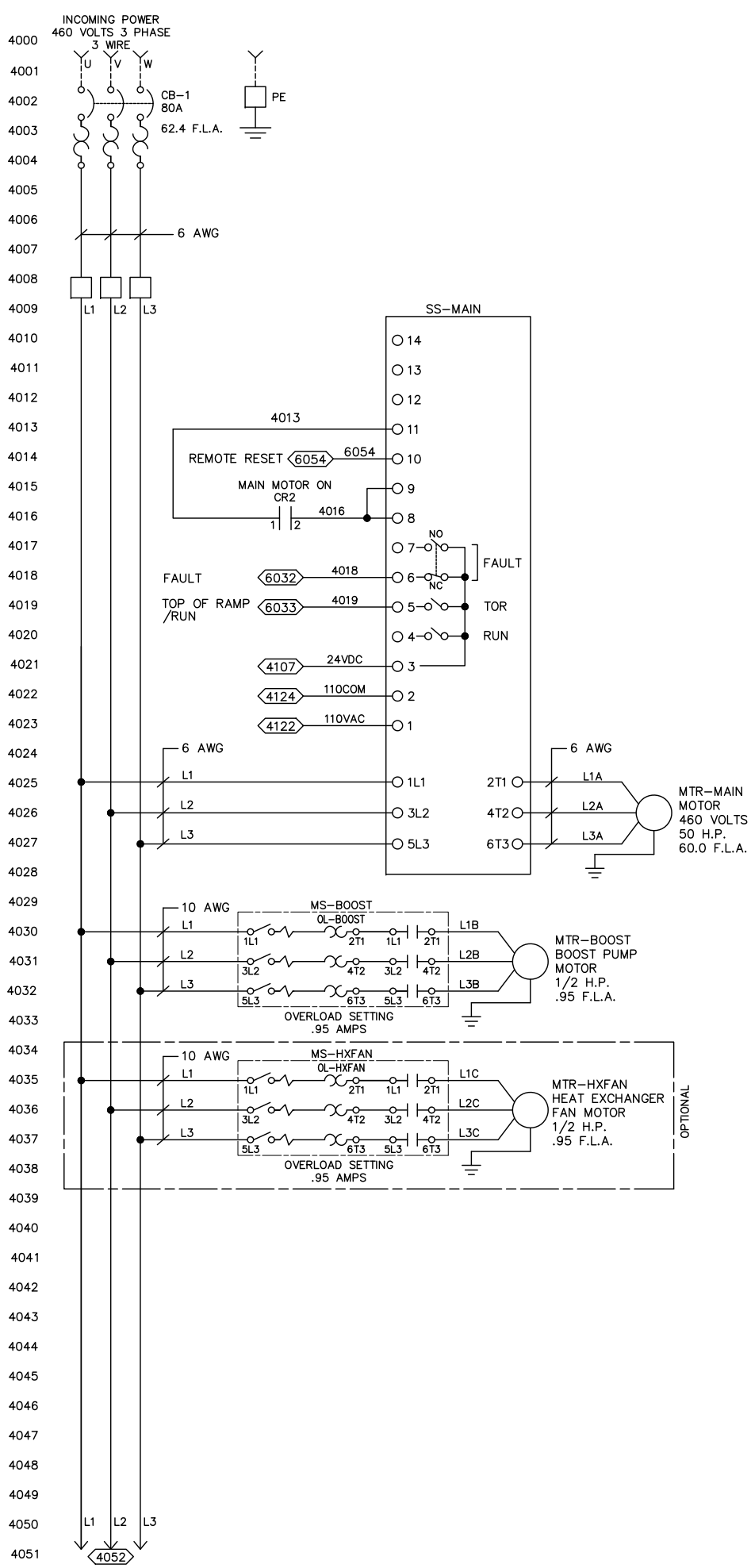

HIGHLY CONFIDENTIAL PROPRIETARY INFORMATION	305 2ND ST NW, STE 115 NEW BRIGHTON, MN 55112 PHONE: 651-294-8600 FAX: 651-294-8620 EMAIL: WATERJET@HYPERTHERM.COM WEB: WWW.HYPERTHERM.COM			TITLE: HyPrecisionS 50, 460V, 60HZ MOTOR AND POWER SUPPLY WIRING		
				DRAWN: SMM CHECKED: XXX ENG APPR: XXX	DATE: 03-26-14	MATERIAL: HARDNESS WEIGHT:
THIS DRAWING AND ALL INFORMATION CONTAINED THEREON IS CONSIDERED PROPRIETARY AND MAY NOT BE USED FOR MANUFACTURING OR FABRICATION PURPOSES WITHOUT PERMISSION FROM HYPERTHERM, INC.	-TOLERANCES- UNLESS OTHERWISE SPECIFIED DIMENSIONS IN INCHES ANGULAR: MACH ± 1 BEND ± 1 ONE PLACE DECIMAL ± .05 TWO PLACE DECIMAL ± .015 THREE PLACE DECIMAL ± .005 BREAK AND DEBURR ALL EDGES .015 MAX		SIZE: B	DWG. NO.: 14797	REV:	

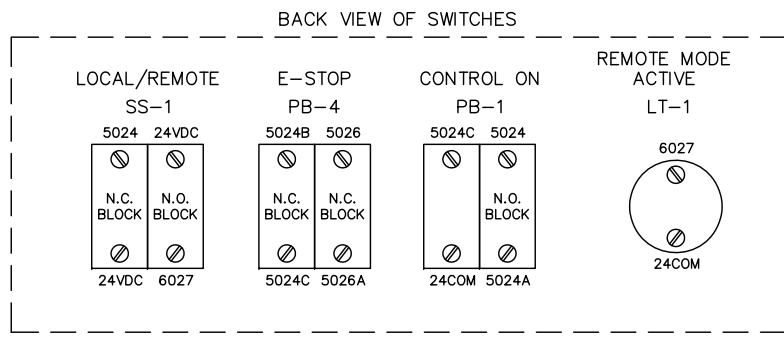
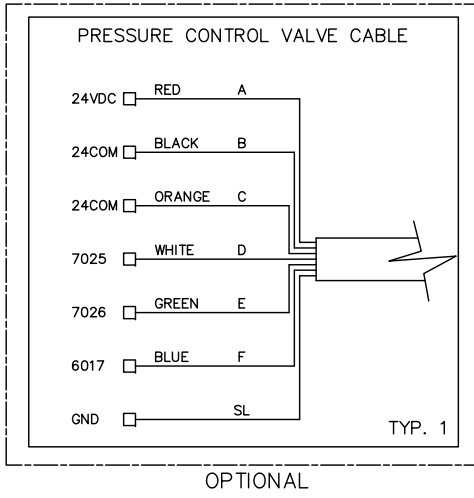
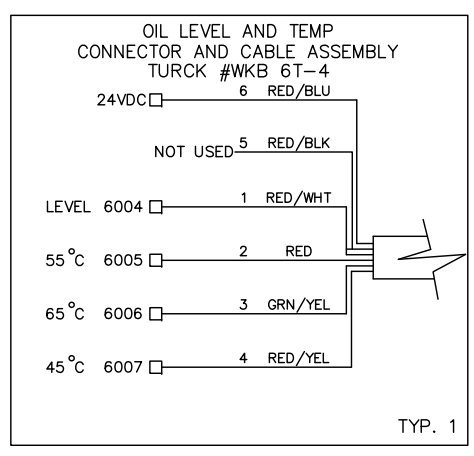
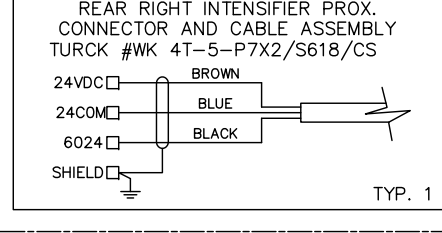
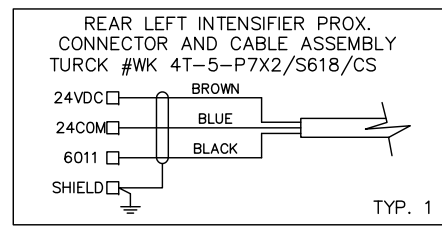
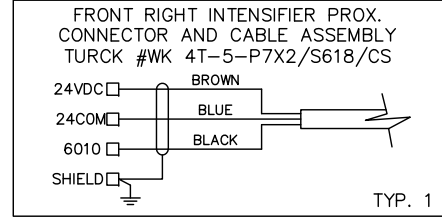
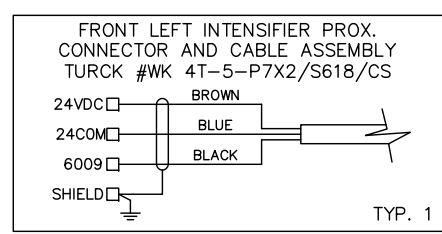
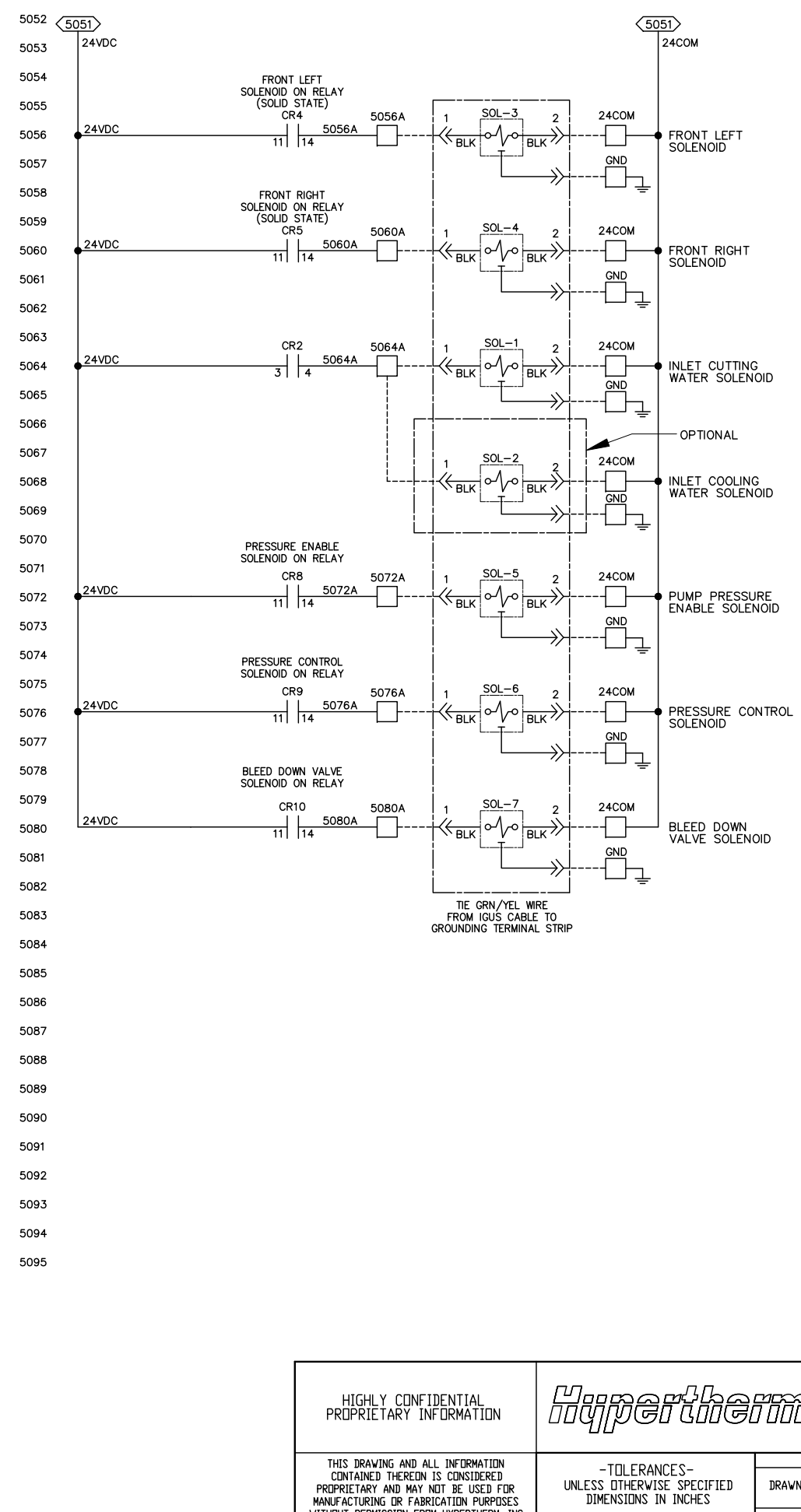
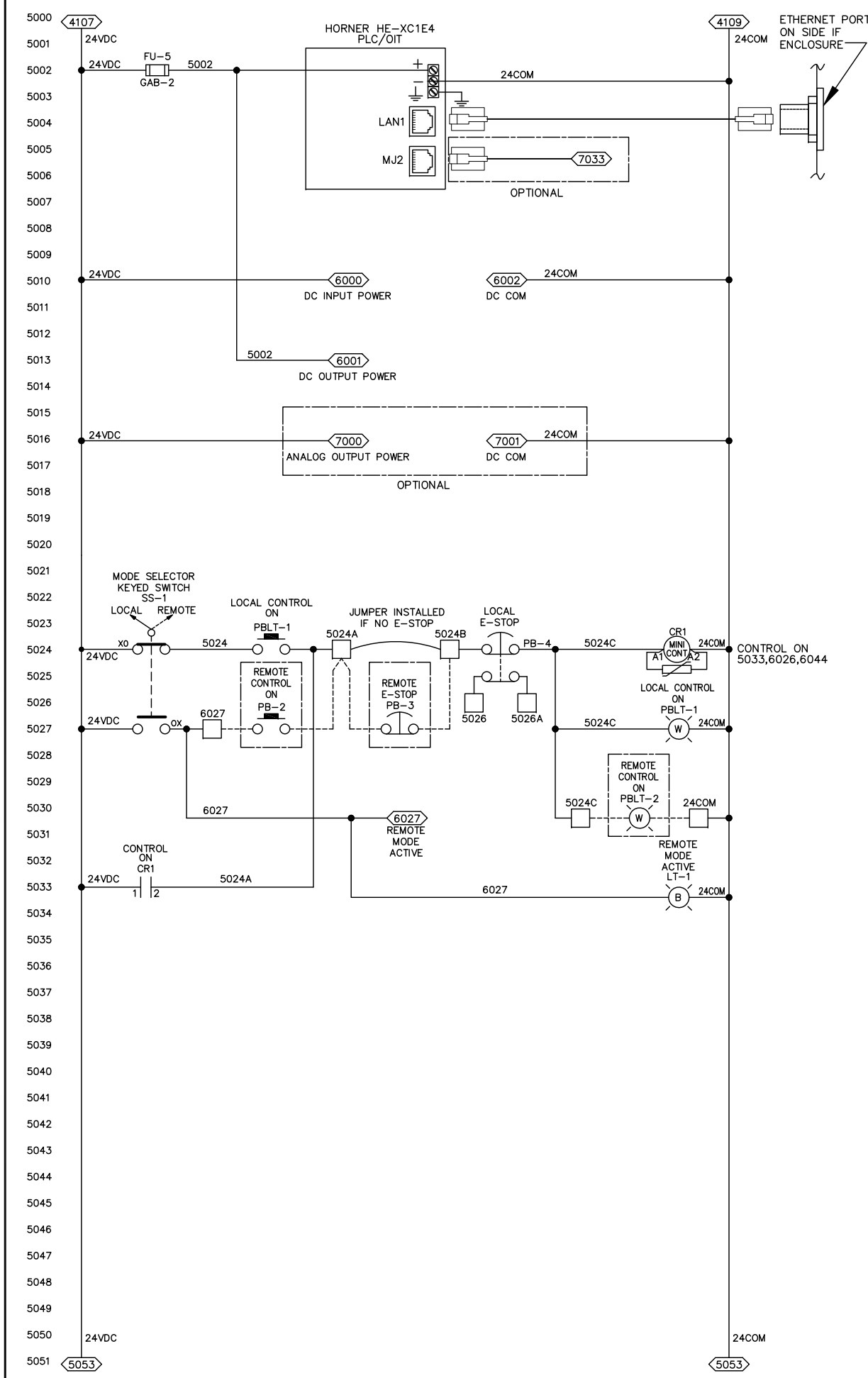

HIGHLY CONFIDENTIAL PROPRIETARY INFORMATION		305 2ND ST NW, STE 115 NEW BRIGHTON, MN 55112 EMAIL: WATERJET@HYPERTHERM.COM WEB: WWW.HYPERTHERM.COM		PHONE: 651-294-8600 FAX: 651-294-8620	TITLE: HyPrecisionS 50, 460V, 60HZ 24VDC CONTROL WIRING		
		THIS DRAWING AND ALL INFORMATION CONTAINED THEREON IS CONSIDERED PROPRIETARY AND MAY NOT BE USED FOR MANUFACTURING OR FABRICATION PURPOSES WITHOUT PERMISSION FROM HYPERTHERM, INC.	-TOLERANCES- UNLESS OTHERWISE SPECIFIED DIMENSIONS IN INCHES ANGULAR: MACH ± 1 BEND ± 1 ONE PLACE DECIMAL ± .05 TWO PLACE DECIMAL ± .015 THREE PLACE DECIMAL ± .005 BREAK AND DEBURR ALL EDGES .015 MAX	DRAWN: SMM CHECKED: XXX ENG APPR: XXX	DATE: 03-26-14	MATERIAL:	SHEET: 5 OF 7
				HARDNESS:	SIZE: B	DWG. NO.: 14797	REV: A

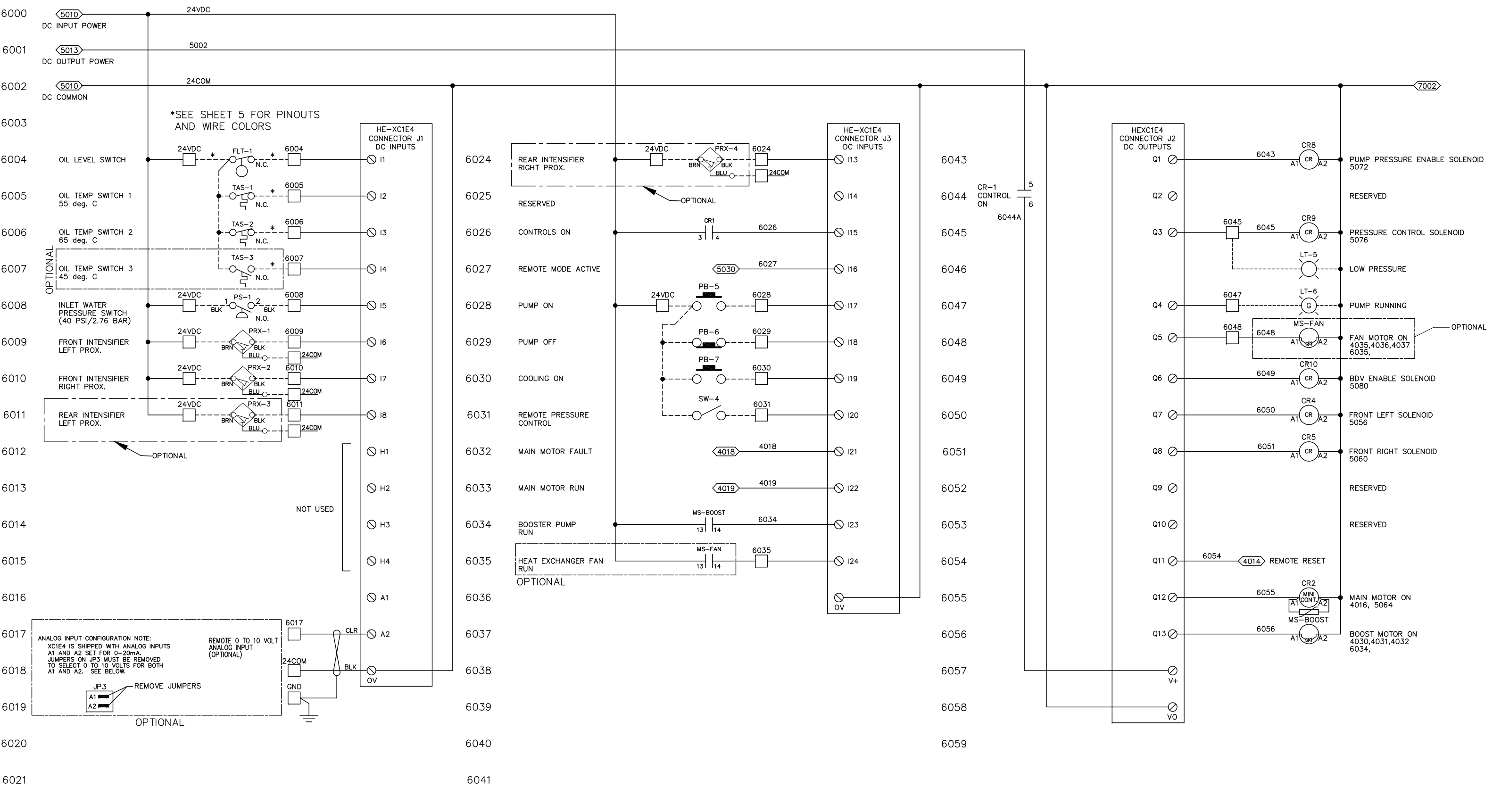

HIGHLY CONFIDENTIAL PROPRIETARY INFORMATION				305 2ND ST NW, STE 115 NEW BRIGHTON, MN 55112 PHONE: 651-294-8600 FAX: 651-294-8620 EMAIL: WATERJET@HYPERTHERM.COM WEB: WWW.HYPERTHERM.COM		TITLE: HyPrecisionS 50, 460V, 60HZ PLC WIRING SHEET 1			
THIS DRAWING AND ALL INFORMATION CONTAINED THEREON IS CONSIDERED PROPRIETARY AND MAY NOT BE USED FOR MANUFACTURING OR FABRICATION PURPOSES WITHOUT PERMISSION FROM HYPERTHERM, INC.		-TOLERANCES- UNLESS OTHERWISE SPECIFIED DIMENSIONS IN INCHES ANGULAR: MACH ± 1 BEND ± 1 ONE PLACE DECIMAL ± .05 TWO PLACE DECIMAL ± .015 THREE PLACE DECIMAL ± .005 BREAK AND DEBURR ALL EDGES .015 MAX		DRAWN: SMM CHECKED: XXX ENG APPR: XXX	DATE: 03-26-14	MATERIAL:	SHEET: 6 OF 7	SCALE: 1:1	FINISH:
				SIZE: B	DWG. NO.: 14797	REV: A			

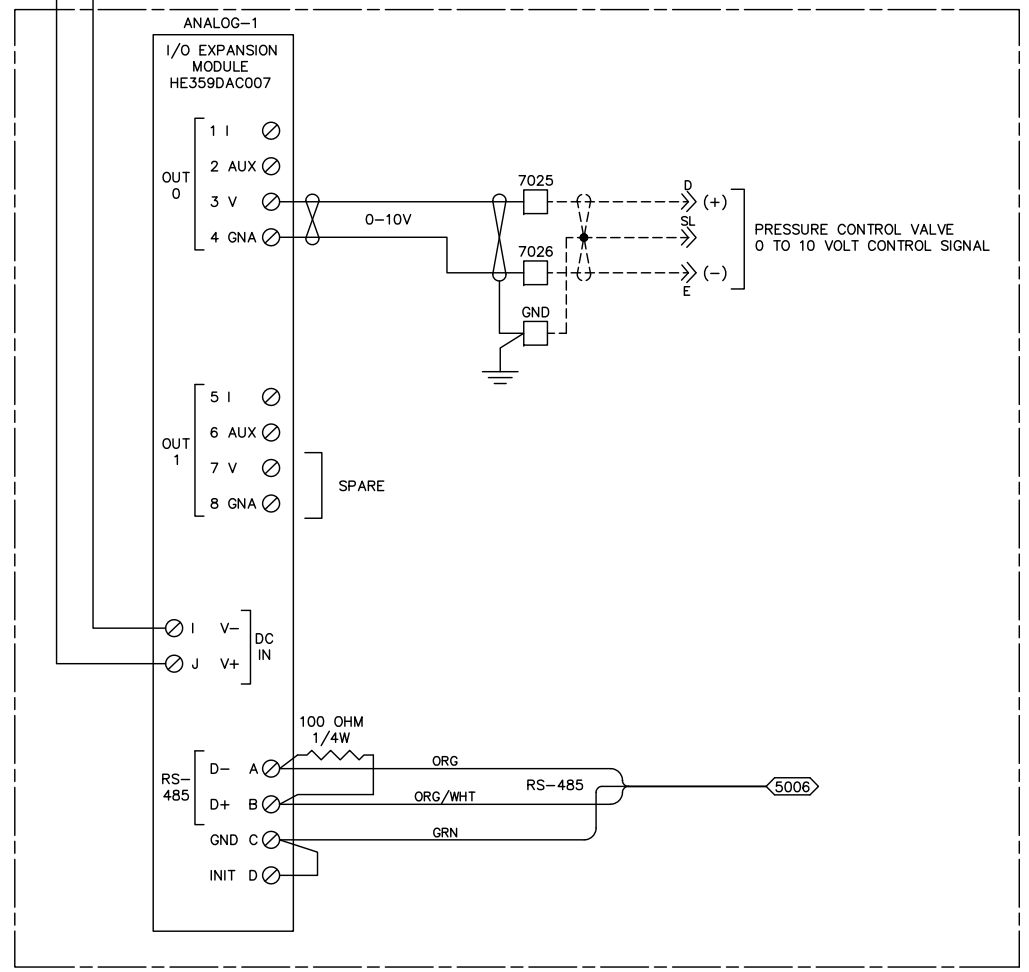
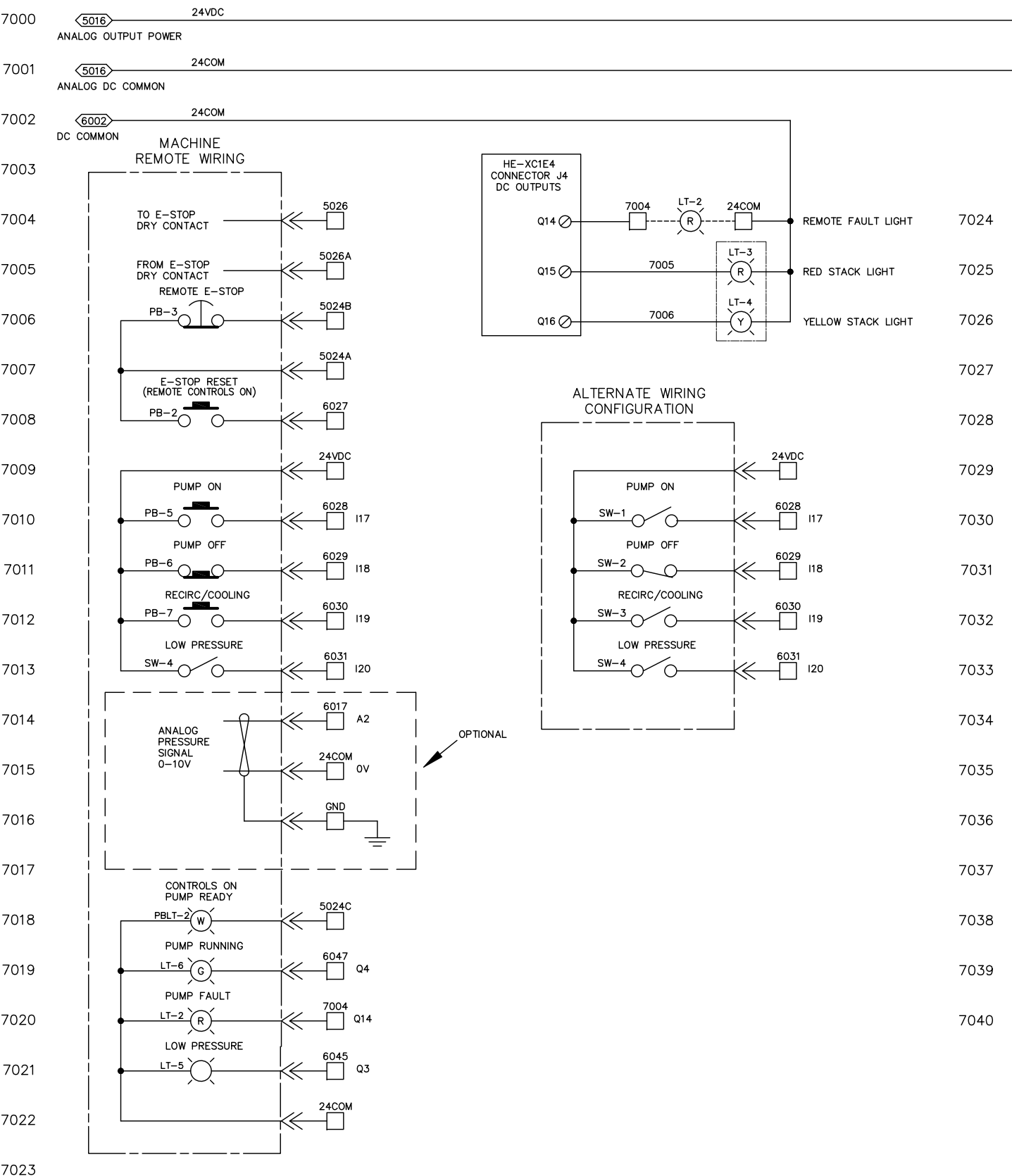

HIGHLY CONFIDENTIAL PROPRIETARY INFORMATION		Hypertherm		305 2ND ST NW, STE 115 NEW BRIGHTON, MN 55112 PHONE: 651-294-8600 FAX: 651-294-8620 EMAIL: WATERJET@HYPERTHERM.COM WEB: WWW.HYPERTHERM.COM		TITLE: HyPrecisionS 50, 460V, 60HZ PLC WIRING SHEET 2			
THIS DRAWING AND ALL INFORMATION CONTAINED THEREON IS CONSIDERED PROPRIETARY AND MAY NOT BE USED FOR MANUFACTURING OR FABRICATION PURPOSES WITHOUT PERMISSION FROM HYPERTHERM, INC.	-TOLERANCES- UNLESS OTHERWISE SPECIFIED DIMENSIONS IN INCHES		DRAWN	SMM	DATE	03-26-14	SHEET 7 OF 7	SCALE: 1:1	FINISH
	ANGULAR: MACH ± 1 BEND ± 1 ONE PLACE DECIMAL ± .05 TWO PLACE DECIMAL ± .015 THREE PLACE DECIMAL ± .005 BREAK AND DEBURR ALL EDGES .015 MAX		CHECKED	XXX	HARDNESS				
			ENG APPR.	XXX	WEIGHT		SIZE B	DWG. NO. 14797	REV A