

ASSEMBLED IN UL CERTIFIED 508A PANEL SHOP

UNLESS OTHERWISE SPECIFIED IN THIS DOCUMENT,
PARTS MUST BE COMPLIANT WITH THE HYPERTHERM
ENVIRONMENTAL SPECIFICATION PN 048266

HIGHLY CONFIDENTIAL PROPRIETARY INFORMATION THIS DRAWING AND ALL INFORMATION CONTAINED THEREON IS CONSIDERED PROPRIETARY AND MAY NOT BE USED FOR MANUFACTURING OR FABRICATION PURPOSES WITHOUT PERMISSION FROM HYPERTHERM, INC.			305 2ND ST NW, STE 115 PHONE: 651-294-8600 NEW BRIGHTON, MN 55112 FAX: 651-294-8620 EMAIL: WATERJET@HYPERTHERM.COM WEB: WWW.HYPERTHERM.COM		TITLE: HyPrecision P-50S 460V 60HZ SS ENCLOSURE ASSEMBLY																						
	-TOLERANCES- UNLESS OTHERWISE SPECIFIED DIMENSIONS IN INCHES ANGULAR: MACH ± 1 BEND ± 1 ONE PLACE DECIMAL ± .05 TWO PLACE DECIMAL ± .015 THREE PLACE DECIMAL ± .005 BREAK AND DEBURR ALL EDGES .015 MAX	<table border="1"> <tr> <th>NAME</th> <th>DATE</th> <th>MATERIAL</th> </tr> <tr> <td>DRAWN: SMM</td> <td>04-06-18</td> <td></td> </tr> <tr> <td>CHECKED: XXX</td> <td></td> <td>HARDNESS</td> </tr> <tr> <td>ENG APPR: XXX</td> <td></td> <td>WEIGHT</td> </tr> </table>	NAME	DATE	MATERIAL	DRAWN: SMM	04-06-18		CHECKED: XXX		HARDNESS	ENG APPR: XXX		WEIGHT	<table border="1"> <tr> <th>SHEET</th> <th>SCALE:</th> <th>FINISH</th> </tr> <tr> <td>1 OF 7</td> <td>1:1</td> <td></td> </tr> </table>	SHEET	SCALE:	FINISH	1 OF 7	1:1		<table border="1"> <tr> <th>SIZE</th> <th>DWG. NO.</th> <th>REV</th> </tr> <tr> <td>B</td> <td>1-17203</td> <td>E</td> </tr> </table>	SIZE	DWG. NO.	REV	B	1-17203
NAME	DATE	MATERIAL																									
DRAWN: SMM	04-06-18																										
CHECKED: XXX		HARDNESS																									
ENG APPR: XXX		WEIGHT																									
SHEET	SCALE:	FINISH																									
1 OF 7	1:1																										
SIZE	DWG. NO.	REV																									
B	1-17203	E																									

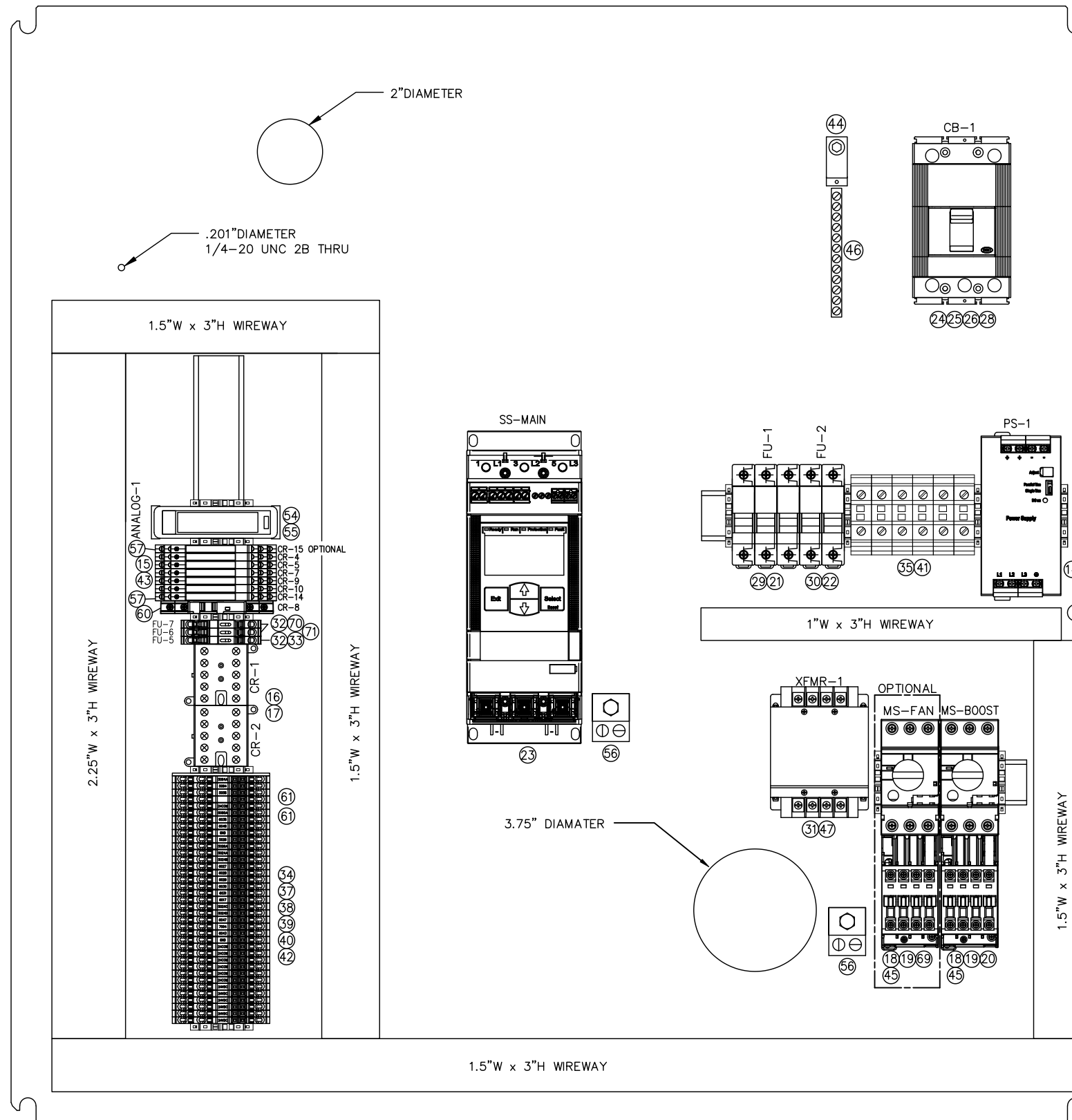

HIGHLY CONFIDENTIAL PROPRIETARY INFORMATION			305 2ND ST NW, STE 115 NEW BRIGHTON, MN 55112 PHONE: 651-294-8600 FAX: 651-294-8620 EMAIL: WATERJET@HYPERTHERM.COM WEB: WWW.HYPERTHERM.COM		TITLE: HyPrecision P-50S 460V 60HZ SS BACK PANEL LAYOUT		
	THIS DRAWING AND ALL INFORMATION CONTAINED THEREON IS CONSIDERED PROPRIETARY AND MAY NOT BE USED FOR MANUFACTURING OR FABRICATION PURPOSES WITHOUT PERMISSION FROM HYPERTHERM, INC.	-TOLERANCES- UNLESS OTHERWISE SPECIFIED DIMENSIONS IN INCHES ANGULAR: MACH ± .1 BEND ± 1 ONE PLACE DECIMAL ± .05 TWO PLACE DECIMAL ± .015 THREE PLACE DECIMAL ± .005 BREAK AND DEBURR ALL EDGES .015 MAX	NAME SMM	DATE 04-06-18	MATERIAL	SHEET 2 OF 7	SCALE: 1:1
		CHECKED XXX		HARDNESS	SIZE B	DWG. NO. 1-17203	REV E

ITEM	QTY.	MANUFACTURER	DESCRIPTION	PART NO.	HYPERTHERM PART NO.
1	1	RITTAL	ENCLOSURE	WM363612NC	1-17047
2	1	HORNER ELECTRIC	PLC/OPERTOR INTERFACE	HE-XC1E4	1-15005
3	1	BANNER	STACK LIGHT	K50LGRYP	1-17436
4	1	ABB	CONTROL POWER ON LIGHT OPERATOR, MOMENTARY, EXTENED, WHITE	MP3-11W	1-14076
5	1	ABB	HOLDER AND CONTACT BLOCK, 1 N.O.	MCBH-101	1-17001
6	1	ABB	LED, 24VDC, WHITE	KA2-2025	1-14055
7	1	IDEC	REMOTE/LOCAL SELECTOR SWITCH OPERATOR, KEYED	HW1K-2A	1-14039
8	1	IDEC	HOLDER AND CONTACT BLOCK, 1 N.O., 1 N.C.	HW-CBF11	1-14040
9	1	ABB	E-STOP OPERATOR, MAINTAINED, TWIST TO RELEASE	MPMT3-10R	1-14077
10	1	ABB	HOLDER AND CONTACT BLOCK, 2 N.C.	MCBH-02	1-14078
11	1	ABB	REMOTE ACTIVE INDICATOR LIGHT, 24VDC, LED, BLUE	CL2-502L	1-14079
12	1	HYPERTHERM	PLC/OPERATOR INTERFACE MOUNTING PLATE	HYPERTHERM	1-14654
13	1	HYPERTHERM	HYPERTHERM OPERATOR FACEPLATE	HYPERTHERM	1-16889
14	1	PULS	POWER SUPPLY, 10 AMP, 24VDC	CT10.241	1-17037
15	5	PHOENIX CONTACT	SOLID STATE RELAY, 24VDC COIL, SPDT	2966634	1-14030
16	2	ABB	MINI CONTACTOR, 24VDC COIL, 4 POLE N.O.	BC6-30-10-01	1-14081
17	2	ABB	SURGE SUPPRESSOR	RV-BC6/60	1-14090
18	1	ABB	CONTACTOR MATING CONNECTOR	BEA16-4	1-15046
19	1	ABB	CONTACTOR, 24VDC COIL, 3 POLE 1 N.O. AUX.	AF09Z-30-10-21	1-15045
20	1	ABB	MANUAL MOTOR PROTECTOR	MS132-1.0	1-16022
21	*4	FERRAZ	FUSE, 600V, TIME DELAY, 6 AMP, CLASS CC	ATQR6	1-14096
22	*3	FERRAZ	FUSE, 600V, TIME DELAY, .3 AMP, CLASS CC	ATQR3/10	1-17318
23	1	ABB	SOFT STARTER	PSE105-600-70	1-16502
24	1	ABB	CIRCUIT BREAKER, 3 POLE, 80 AMP	XT1NQ3080AAA000XXX	1-17017
25	1	ABB	DISCONNECT KEY LOCKOUT KIT	KXTARHLOPCL	1-17319
26	1	ABB	ROTARY HANDLE MECHANISM	KXTBRHEBFP	1-17320
27	1	ABB	ROTARY HANDLE	OHB65J10B	1-17325
28	1	ABB	SHAFT	EXP10X500	1-17321
29	1	ABB	FUSE HOLDER, 3 POLE, CLASS CC, LIGHTED	E93/30CCS	1-17332
30	1	ABB	FUSE HOLDER, 2 POLE, CLASS CC, LIGHTED	E92/30CCS	1-17026
31	1	SOLA/HD	TRANSFORMER 460/230V-120V, 50VA	E050	1-17048
32	3	PHOENIX CONTACT	FUSE HOLDER, 1 POLE, 24VDC LIGHTED, 1 1/4 x 1/4 FUSE	3038765	1-14095
33	*2	FERRAZ	FUSE, 250V 2 AMP, FAST ACTING, CERAMIC 1 1/4 x 1/4	GAB-2	1-14098
34	35	PHOENIX CONTACT	TERMINAL BLOCK, PT2.5-TWIN	3209549	1-14100
35	6	PHOENIX CONTACT	TERMINAL BLOCK, SCREW, UT 35	3044225	1-17042
36	N/A				
37	1	PHOENIX CONTACT	TERMINAL BLOCK, END PLATE	3030488	1-14102
38	11	PHOENIX CONTACT	TERMINAL BLOCK, END BARRIER 5.2MM	3022276	1-18405
39	2	PHOENIX CONTACT	TERMINAL BLOCK JUMPER, 10 POSITION	3030213	1-14103
40	2	PHOENIX CONTACT	TERMINAL BLOCK JUMPER, 2 POSITION	3030161	1-14037
41	3	PHOENIX CONTACT	TERMINAL BLOCK, JUMPER, 2 POSITION 16mm	3005963	1-17040
42	2	PHOENIX CONTACT	TERMINAL BLOCK, PT2.5-TWIN-PE	3209565	1-14101
43	1/2	PHOENIX CONTACT	SOLID STATE RELAY JUMPER, 20 POSITION	2966692	1-14105
44	1	T&B-BLACKBURN	GROUND LUG	ADR21	1-17051
45	1	ABB	POWER FEED TERMINAL	S1-M3-25	1-17006
46	1	SIEMENS	10 HOLE GROUND BAR	GB10	1-14109
47	1	SOLA/HD	TRANSFORMER TERMINAL COVERS	IP20	1-17049
48	1	PHOENIX CONTACT	RJ45 ADAPTOR	1689064	1-17033
49	1	PHOENIX CONTACT	RJ45 FRAME	1689844	1-17034
50	1	PHOENIX CONTACT	FRAME CAP	1652606	1-17032
51	1	BELKIN	CAT 5E ETHERNET CABLE, 7FT.	A3L791-07-BLU-M	1-17023
52	6	HAMMOND	HOLE PLUG, STEEL, 22mm PUSHBUTTON	HP22	1-17030
53	1	HAMMOND	HOLE PLUG, STEEL, 1.25"	HP125	1-17028
54	1	HORNER ELECTRIC	ANALOG INPUT MODULE, 4 CHANNEL	HE359ADC107	1-17031
55	1	HORNER ELECTRIC	PLC TO SMARTMOD INTERFACE CABLE	TPCCBL	1-14112
56	2	T&B-BLACKBURN	DOUBLE GROUND LUG	ADR11-21	1-17050
57	1	PHOENIX CONTACT	RELAY, 24VDC COIL, 1 PDT	2966171	1-17388
58	N/A				
59	1	RITTAL	PRINT POCKET	2514.000	1-17045

60	1	CRYDOM	SOLID STATE RELAY, 24VDC	DR06D06	1-17024
61	2	VISHAY	FLYBACK DIODE	UG4D-E3/54	1-17085
62	1	T & B	CABLE GLAND, 1/2NPT	CC-NPT-12-G	1-17052
63	1	T & B	CABLE GLAND LOCKNUT, 1/2 NPT	LN-501	1-17317
64	1	TURCK	JUNCTION BOX, CUSTOM VBM 80	U2-31197	1-17125
65	1	BANNER	STACKLIGHT BASE	SA-E12M30	1-17146
66	1	BANNER	STACKLIGHT STAND-OFF PIPE	SOP-E12-300A	1-17147
67	1	BANNER	STACKLIGHT PIPE ADAPTOR	SA-M30TE12	1-17323
68	1	KINGSTON	SD MEMORY CARD, 32GB	MBLY10G2/32GB	1-17355
69	1	HAMMOND	HOLE PLUG, STEEL, 2"	HP200	1-17029
70	*3	FERRAZ	FUSE, 250V 4AMP, TIME DELAY, CERAMIC 1 1/4 X 1/4	GSA-4	1-18406
71	1	PHOENIX CONTACT	TERMINAL BLOCK JUMPER, 3 POSITION 8.2mm PITCH	3030297	1-18423

SHIP ONE LOOSE AS SPARE

SHIP ONE LOOSE AS SPARE

SHIP ONE LOOSE AS SPARE

AIR COOLED HEAT EXCHANGER OPTION

ITEM	QTY.	MANUFACTURER	DESCRIPTION	PART NO.	HYPERTHERM PART NO.
18	1	ABB	CONTACTOR MATING CONNECTOR	BEA16-4	1-15046
19	1	ABB	CONTACTOR, 24VDC COIL, 3 POLE 1 N.O. AUX.	AF09Z-30-10-21	1-15045
69	1	ABB	MANUAL MOTOR PROTECTOR	MS132-1.6	1-16023
45	1	ABB	POWER FEED TERMINAL	S1-M3-25	1-17006
57	1	PHOENIX CONTACT	RELAY, 24VDC COIL, 1 PDT	2966171	1-17388

SHIP ONE LOOSE AS SPARE

* QUANTITIES OF FUSES LISTED INCLUDE SPARES

HIGHLY CONFIDENTIAL PROPRIETARY INFORMATION			305 2ND ST NW, STE 115 NEW BRIGHTON, MN 55112 EMAIL: WATERJET@HYPERTHERM.COM WEB: WWW.HYPERTHERM.COM		PHONE: 651-294-8600 FAX: 651-294-8620		TITLE: HyPrecision P-50S 460V 60HZ SS BILL OF MATERIALS			
	THIS DRAWING AND ALL INFORMATION CONTAINED THEREON IS CONSIDERED PROPRIETARY AND MAY NOT BE USED FOR MANUFACTURING OR FABRICATION PURPOSES WITHOUT PERMISSION FROM HYPERTHERM, INC.	-TOLERANCES- UNLESS OTHERWISE SPECIFIED DIMENSIONS IN INCHES ANGULAR: MACH ± .1 BEND ± .1 ONE PLACE DECIMAL ± .05 TWO PLACE DECIMAL ± .015 THREE PLACE DECIMAL ± .005 BREAK AND DEBURR ALL EDGES .015 MAX	DRAWN SMM	DATE 04-06-18	MATERIAL	SHEET 3 OF 7	SCALE: 1:1	FINISH	SIZE B	DWG. NO. 1-17203

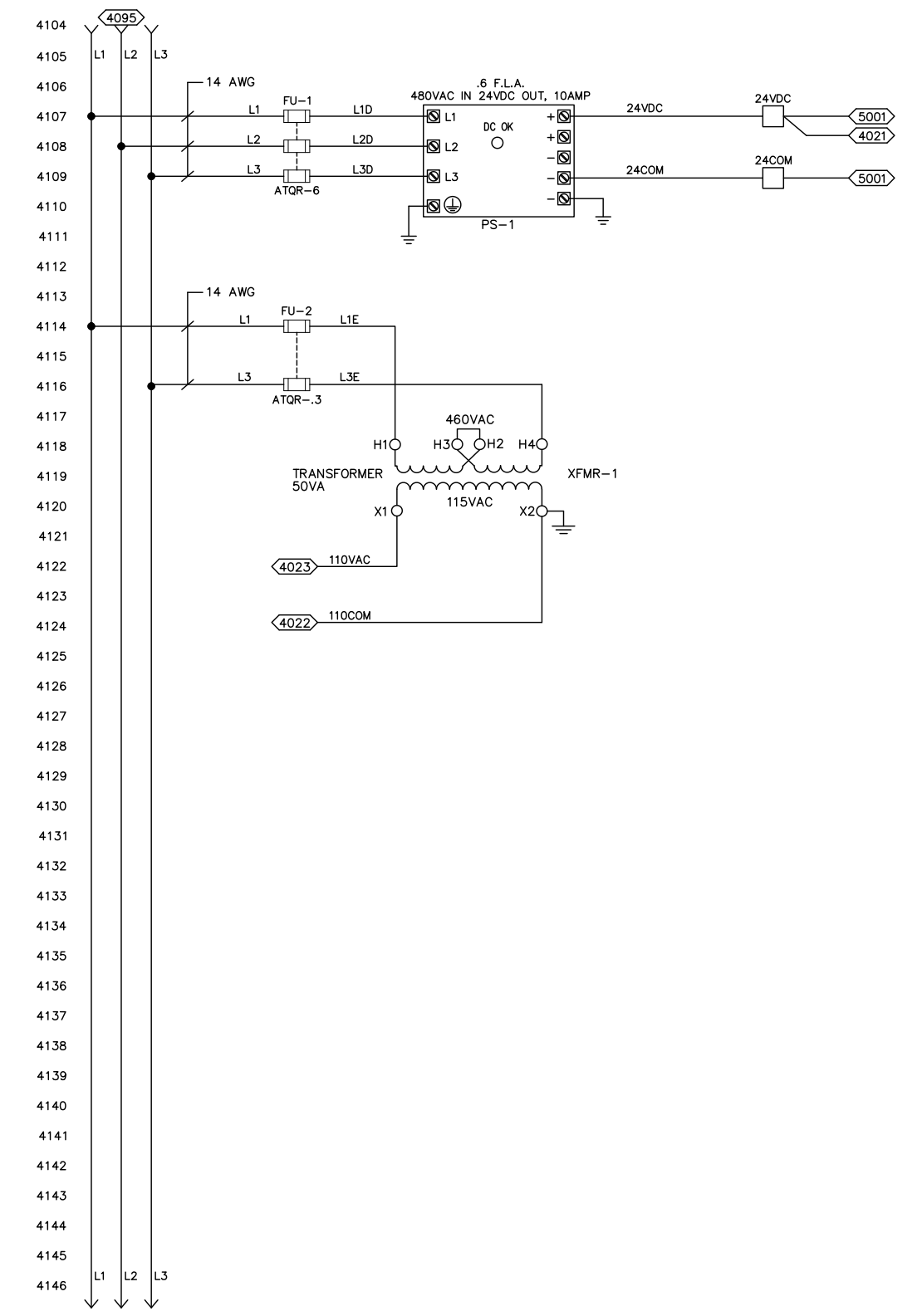
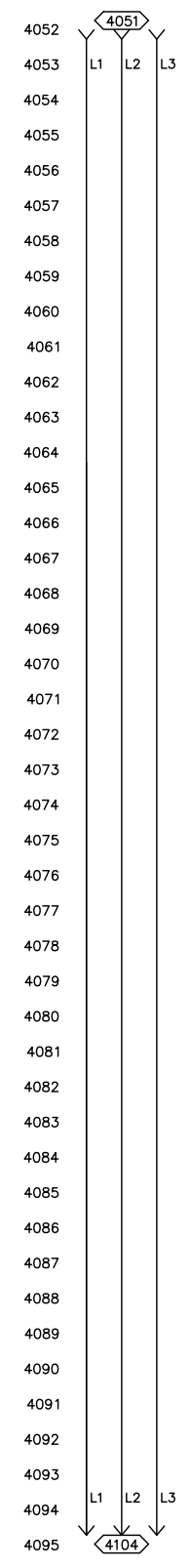
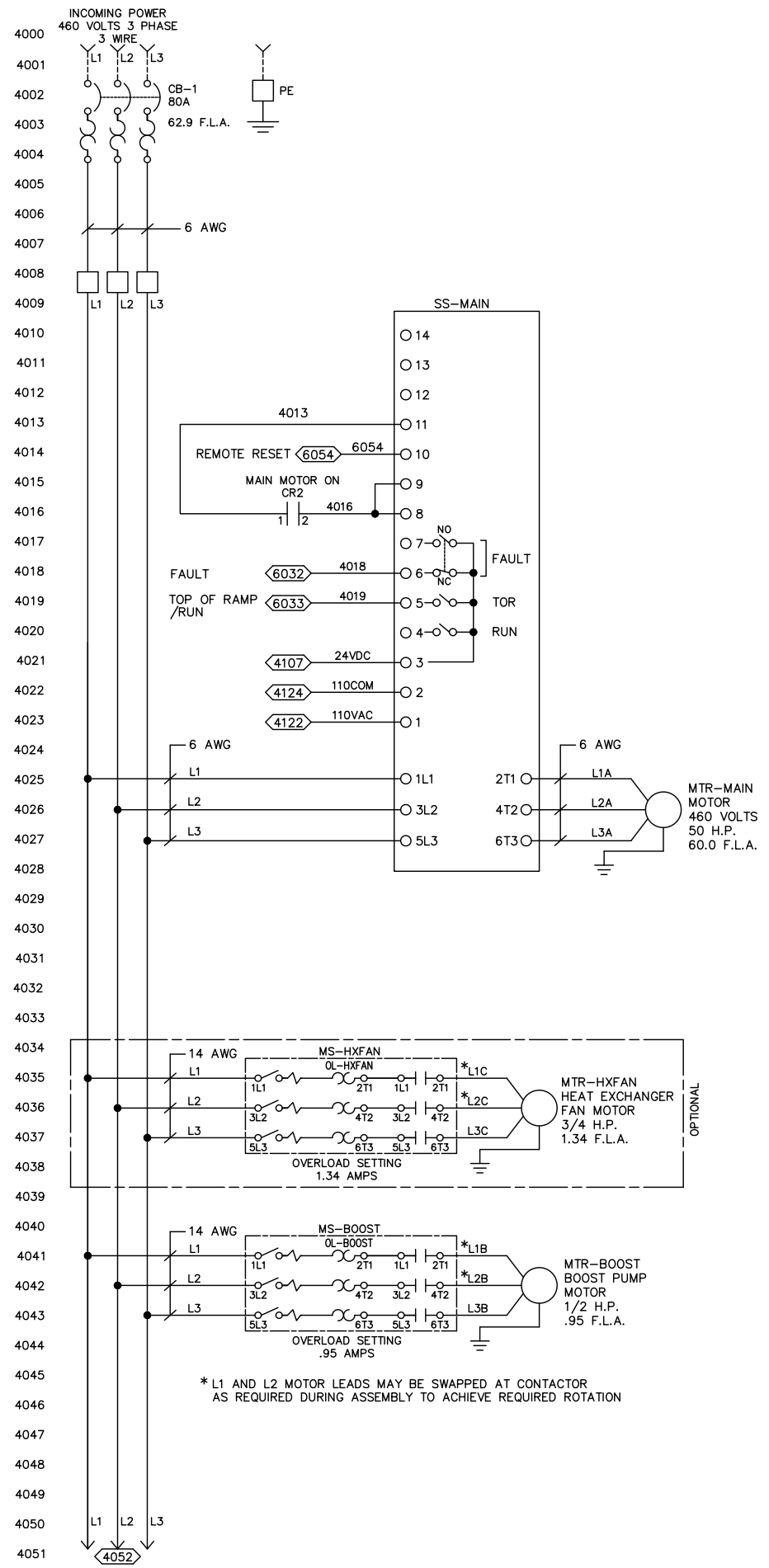

HIGHLY CONFIDENTIAL PROPRIETARY INFORMATION	Hypertherm		305 2ND ST NW, STE 115 NEW BRIGHTON, MN 55112 PHONE: 651-294-8600 FAX: 651-294-8620 EMAIL: WATERJET@HYPERTHERM.COM WEB: WWW.HYPERTHERM.COM		TITLE: HyPrecision P-50S 460V 60HZ SS MOTOR AND POWER SUPPLY WIRING																	
	THIS DRAWING AND ALL INFORMATION CONTAINED THEREON IS CONSIDERED PROPRIETARY AND MAY NOT BE USED FOR MANUFACTURING OR FABRICATION PURPOSES WITHOUT PERMISSION FROM HYPERTHERM, INC.		-TOLERANCES- UNLESS OTHERWISE SPECIFIED DIMENSIONS IN INCHES ANGULAR: MACH ± .1 BEND ± 1 ONE PLACE DECIMAL ± .05 TWO PLACE DECIMAL ± .015 THREE PLACE DECIMAL ± .005 BREAK AND DEBURR ALL EDGES .015 MAX		<table border="1"> <tr> <td>DRAWN</td> <td>SMM</td> <td>DATE</td> <td>04-06-18</td> <td>MATERIAL</td> </tr> <tr> <td>CHECKED</td> <td>XXX</td> <td></td> <td></td> <td>HARDNESS</td> </tr> <tr> <td>ENG APPR.</td> <td>XXX</td> <td></td> <td></td> <td>WEIGHT</td> </tr> </table>	DRAWN	SMM	DATE	04-06-18	MATERIAL	CHECKED	XXX			HARDNESS	ENG APPR.	XXX			WEIGHT	SHEET 4 OF 7	SCALE: 1:1
DRAWN	SMM	DATE	04-06-18	MATERIAL																		
CHECKED	XXX			HARDNESS																		
ENG APPR.	XXX			WEIGHT																		
				SIZE B	DWG. NO. 1-17203	REV E																

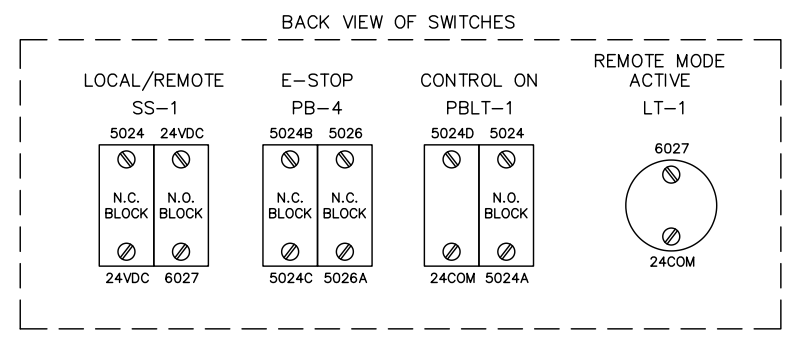
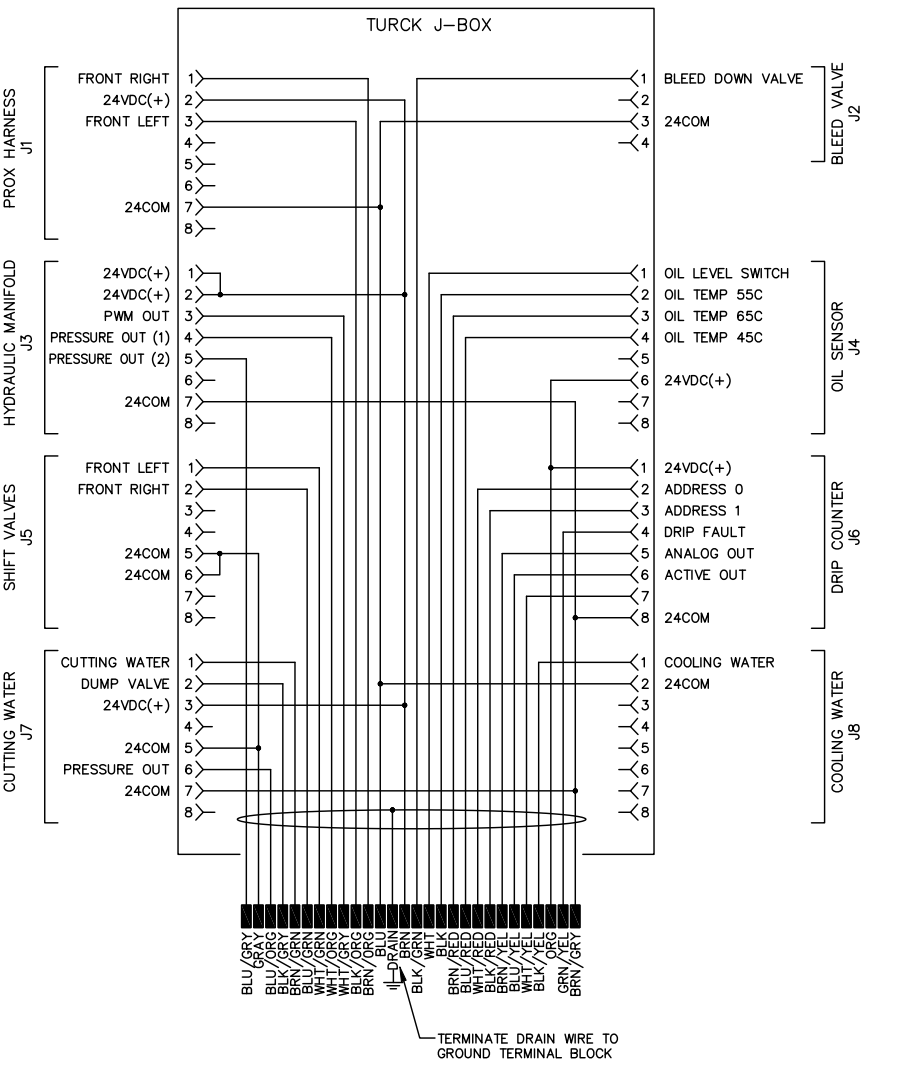
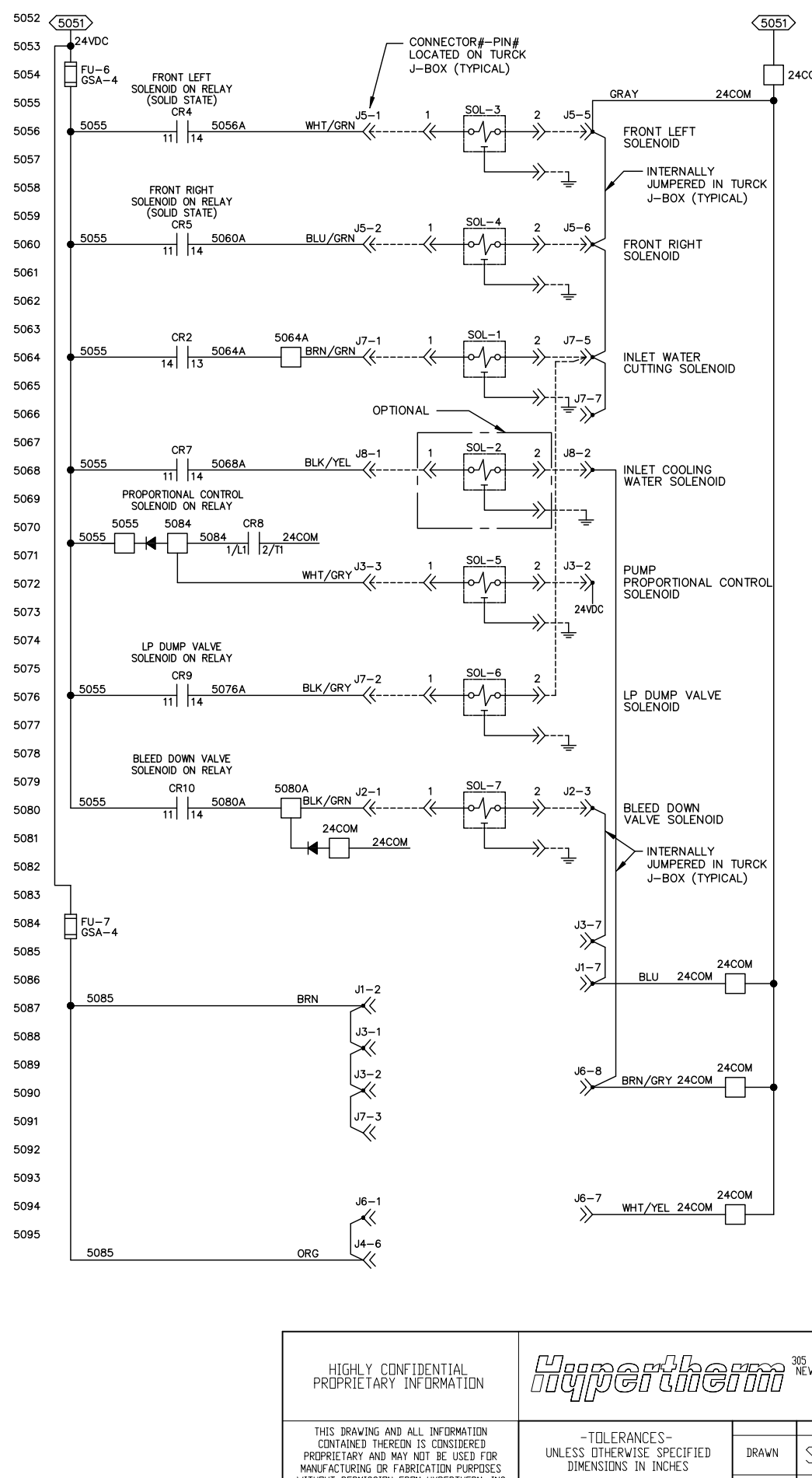
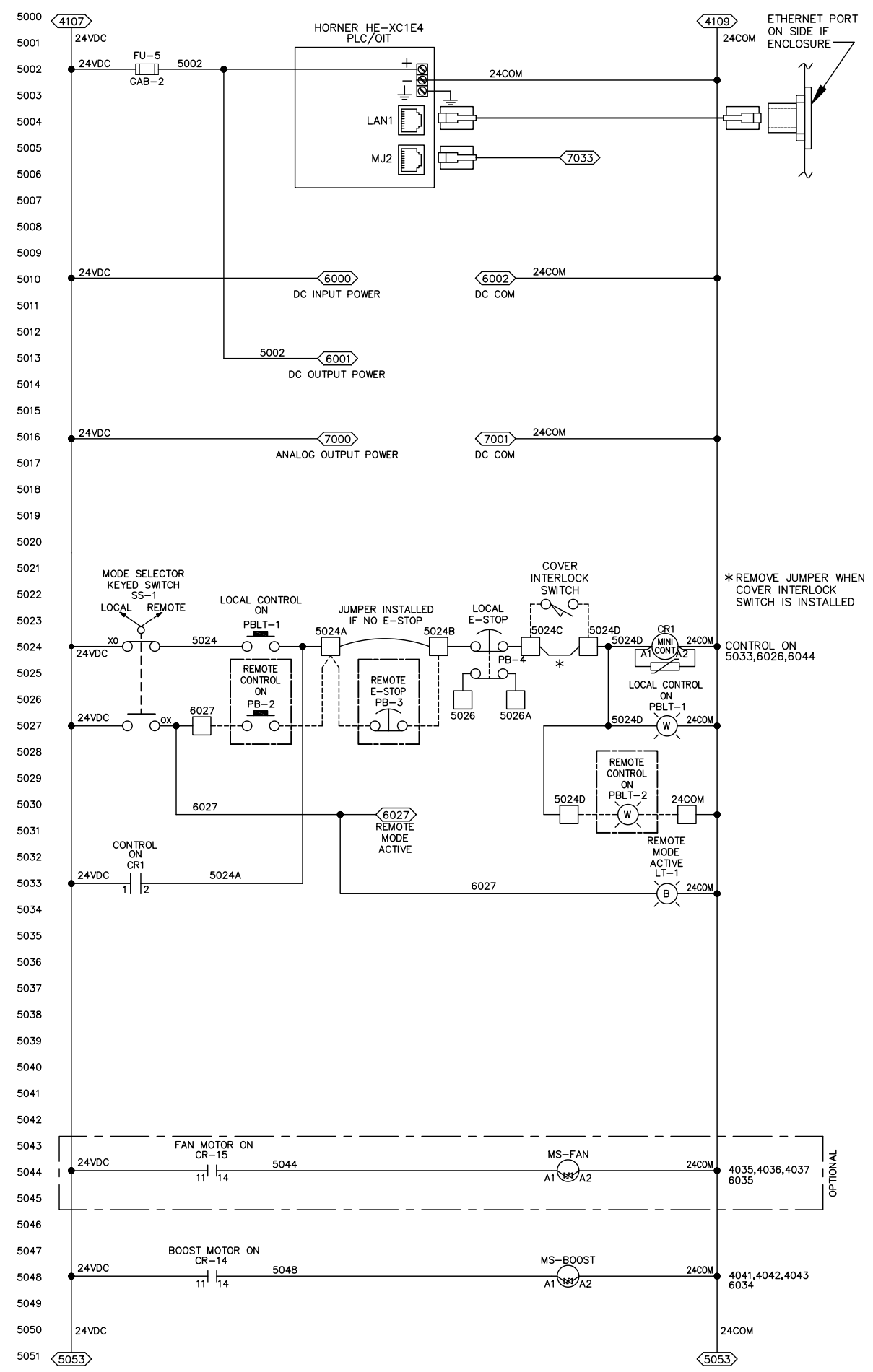

HIGHLY CONFIDENTIAL PROPRIETARY INFORMATION

Hypertherm 305 2ND ST NW, STE 115 NEW BRIGHTON, MN 55112 PHONE: 651-294-8600 FAX: 651-294-8620 EMAIL: WATERJET@HYPERTHERM.COM WEB: WWW.HYPERTHERM.COM

TITLE: HyPrecision P-50S 460V 60HZ SS 24VDC CONTROL WIRING

THIS DRAWING AND ALL INFORMATION CONTAINED THEREON IS CONSIDERED PROPRIETARY AND MAY NOT BE USED FOR MANUFACTURING OR FABRICATION PURPOSES WITHOUT PERMISSION FROM HYPERTHERM, INC.	-TOLERANCES- UNLESS OTHERWISE SPECIFIED DIMENSIONS IN INCHES ANGULAR: MACH ± .1 BEND ± 1 ONE PLACE DECIMAL ± .05 TWO PLACE DECIMAL ± .015 THREE PLACE DECIMAL ± .005 BREAK AND DEBURR ALL EDGES .015 MAX	<table border="1"> <tr><th>NAME</th><th>DATE</th><th>MATERIAL</th></tr> <tr><td>SMM</td><td>04-06-18</td><td></td></tr> <tr><th>CHECKED</th><td>XXX</td><td>HARDNESS</td></tr> <tr><th>ENG APPR.</th><td>XXX</td><td>WEIGHT</td></tr> </table>	NAME	DATE	MATERIAL	SMM	04-06-18		CHECKED	XXX	HARDNESS	ENG APPR.	XXX	WEIGHT	<table border="1"> <tr><th>SHEET</th><th>SCALE:</th><th>FINISH</th></tr> <tr><td>5 OF 7</td><td>1:1</td><td></td></tr> <tr><th>SIZE</th><th>DWG. NO.</th><th>REV</th></tr> <tr><td>B</td><td>1-17203</td><td>E</td></tr> </table>	SHEET	SCALE:	FINISH	5 OF 7	1:1		SIZE	DWG. NO.	REV	B	1-17203	E
NAME	DATE	MATERIAL																									
SMM	04-06-18																										
CHECKED	XXX	HARDNESS																									
ENG APPR.	XXX	WEIGHT																									
SHEET	SCALE:	FINISH																									
5 OF 7	1:1																										
SIZE	DWG. NO.	REV																									
B	1-17203	E																									

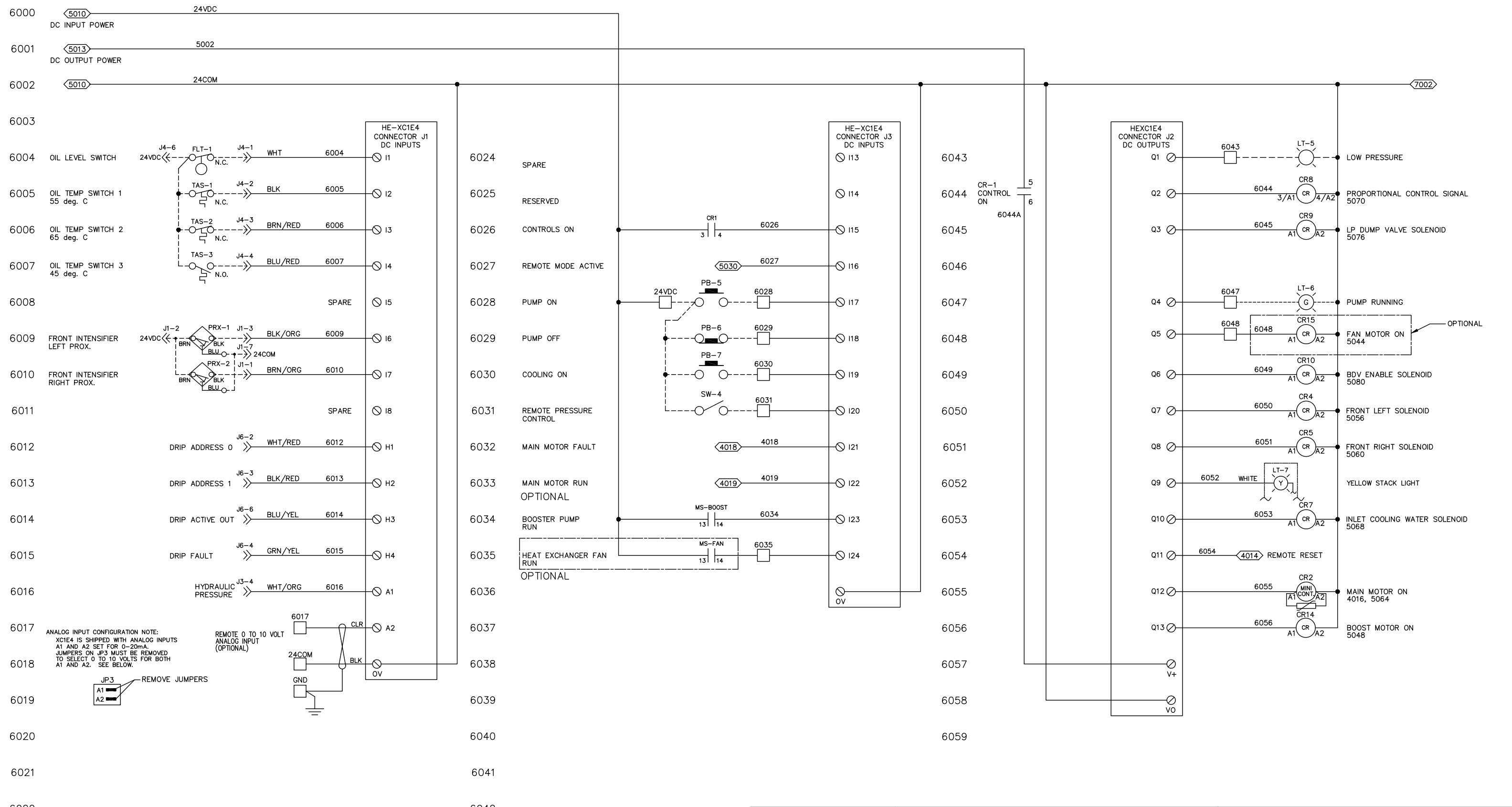

ANALOG INPUT CONFIGURATION NOTE:
 XC1E4 IS SHIPPED WITH ANALOG INPUTS
 A1 AND A2 SET FOR 0-20mA
 JUMPERS ON JP3 MUST BE REMOVED
 TO SELECT 0 TO 10 VOLTS FOR BOTH
 A1 AND A2. SEE BELOW.

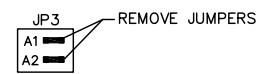

REMOTE 0 TO 10 VOLT
 ANALOG INPUT
 (OPTIONAL)

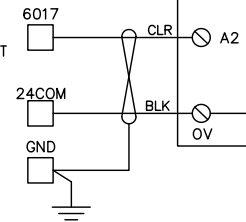

HIGHLY CONFIDENTIAL PROPRIETARY INFORMATION					305 2ND ST NW, STE 115 PHONE: 651-294-8600 NEW BRIGHTON, MN 55112 FAX: 651-294-8620 EMAIL: WATERJET@HYPERTHERM.COM WEB: WWW.HYPERTHERM.COM		TITLE: HyPrecision P-50S 460V 60HZ SS PLC WIRING SHEET 1		
THIS DRAWING AND ALL INFORMATION CONTAINED THEREON IS CONSIDERED PROPRIETARY AND MAY NOT BE USED FOR MANUFACTURING OR FABRICATION PURPOSES WITHOUT PERMISSION FROM HYPERTHERM, INC.		-TOLERANCES- UNLESS OTHERWISE SPECIFIED DIMENSIONS IN INCHES ANGULAR: MACH ± 1 BEND ± 1 ONE PLACE DECIMAL ± .05 TWO PLACE DECIMAL ± .015 THREE PLACE DECIMAL ± .005 BREAK AND DEBURR ALL EDGES .015 MAX		DRAWN: SMM CHECKED: XXX ENG APPR: XXX	NAME: DATE: 04-06-18 MATERIAL: HARDNESS: WEIGHT:	SHEET: 6 OF 7 SCALE: 1:1 FINISH:	SIZE: B DWG. NO.: 1-17203 REV: E		

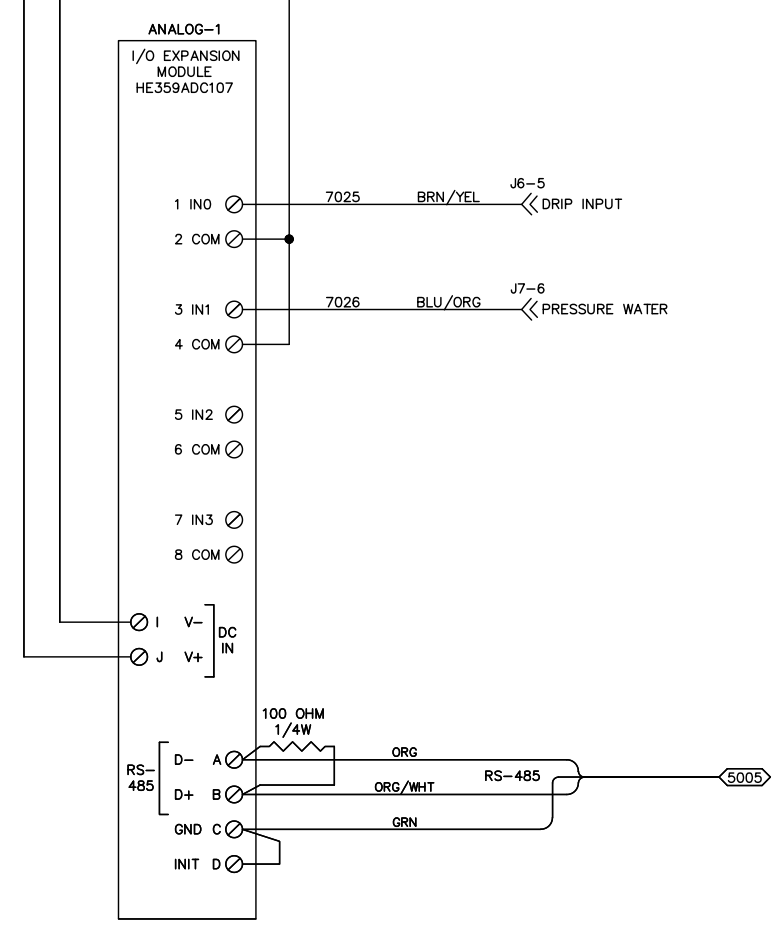
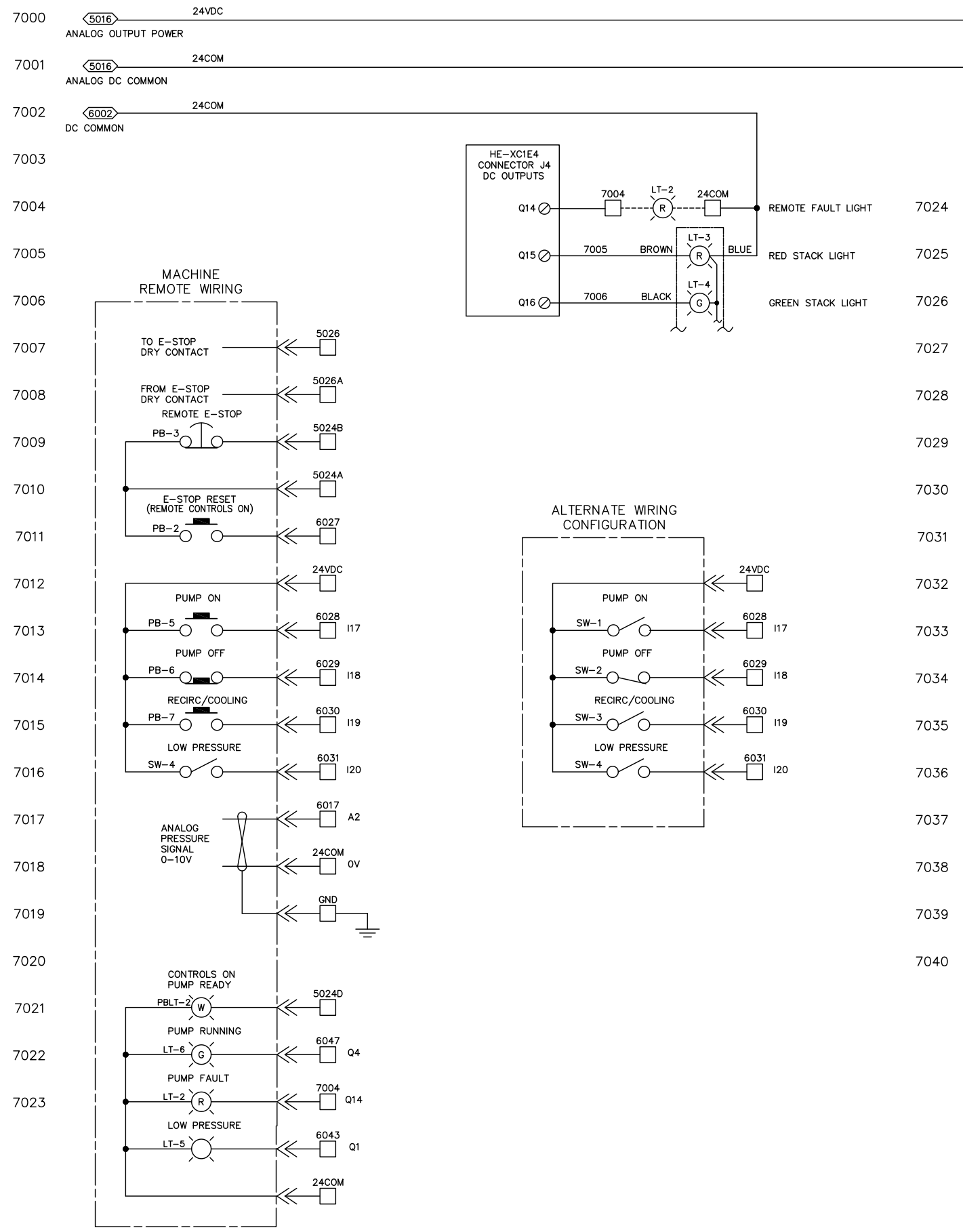

HIGHLY CONFIDENTIAL PROPRIETARY INFORMATION				305 2ND ST NW, STE 115 NEW BRIGHTON, MN 55112 PHONE: 651-294-8600 FAX: 651-294-8620 EMAIL: WATERJET@HYPERTHERM.COM WEB: WWW.HYPERTHERM.COM		TITLE: HyPrecision P-50S 460V 60HZ SS PLC WIRING SHEET 2																						
	THIS DRAWING AND ALL INFORMATION CONTAINED THEREON IS CONSIDERED PROPRIETARY AND MAY NOT BE USED FOR MANUFACTURING OR FABRICATION PURPOSES WITHOUT PERMISSION FROM HYPERTHERM, INC.	-TOLERANCES- UNLESS OTHERWISE SPECIFIED DIMENSIONS IN INCHES ANGULAR: MACH ± 1 BEND ± 1 ONE PLACE DECIMAL ± .05 TWO PLACE DECIMAL ± .015 THREE PLACE DECIMAL ± .005 BREAK AND DEBURR ALL EDGES .015 MAX	<table border="1"> <tr> <th>NAME</th> <th>DATE</th> <th>MATERIAL</th> </tr> <tr> <td>DRAWN SMM</td> <td>04-06-18</td> <td></td> </tr> <tr> <td>CHECKED XXX</td> <td></td> <td>HARDNESS</td> </tr> <tr> <td>ENG APPR. XXX</td> <td></td> <td>WEIGHT</td> </tr> </table>	NAME	DATE	MATERIAL	DRAWN SMM	04-06-18		CHECKED XXX		HARDNESS	ENG APPR. XXX		WEIGHT	<table border="1"> <tr> <th>SHEET</th> <th>SCALE:</th> <th>FINISH</th> </tr> <tr> <td>7 OF 7</td> <td>1:1</td> <td></td> </tr> </table>	SHEET	SCALE:	FINISH	7 OF 7	1:1		<table border="1"> <tr> <th>SIZE</th> <th>DWG. NO.</th> <th>REV</th> </tr> <tr> <td>B</td> <td>1-17203</td> <td>E</td> </tr> </table>	SIZE	DWG. NO.	REV	B	1-17203
NAME	DATE	MATERIAL																										
DRAWN SMM	04-06-18																											
CHECKED XXX		HARDNESS																										
ENG APPR. XXX		WEIGHT																										
SHEET	SCALE:	FINISH																										
7 OF 7	1:1																											
SIZE	DWG. NO.	REV																										
B	1-17203	E																										