



STREAMLINE HIGH PRESSURE WATERJET PUMP



OPERATION and SERVICE MANUAL

**SL-IV 15hp HSEC
208/230**

Manual No. 05139142

NOTICE

This document contains subject matter in which KMT Waterjet Systems has proprietary rights. Recipients of this document shall not duplicate, use, or disclose information contained herein, in whole or in part, for other than the purpose for which this manual was provided.

KMT Waterjet Systems believes the information described in this manual to be accurate and reliable. Much care has been taken in its preparation, however, the Company cannot accept any responsibility, financial or otherwise, for any consequences arising out of the use of this material. The information contained herein is subject to change, and revisions may be issued to advise of such changes and/or additions.

KMT WATERJET SYSTEMS



KMT Waterjet Systems
635 West 12th Street, P.O. Box 231
Baxter Springs, Kansas 66713

Tel. (800) 826-9274
Fax (620) 856-5050

TABLE of CONTENTS

SECTION 1 INTRODUCTION

1	SL-IV 11kW (15 hp) Waterjet Pump General Information	1-1
1.1	Physical Description	1-2
1.1.1	Standard Equipment	1-2
1.2	Functional Description	1-3
1.2.1	Functional Features	1-3
1.3	Worldwide Product Support	1-4
1.3.1	Service Department	1-4
1.3.2	Spare Parts	1-4
1.3.3	Questionnaire	1-4
1.4	Safety	1-7
1.4.1	Labels and Abbreviations	1-7
1.4.2	Safety Procedures	1-9
1.4.3	High Pressure (HP) Piping Safety	1-11
1.4.4	Emergency Medical Treatment	1-12

SECTION 2 INSTALLATION

2	Installation	2-1
2.1	Installation Overview	2-1
2.1.1	Buyer Obligations	2-1
2.1.2	Seller Obligations	2-1
2.2	Installation Requirements (Utilities)	2-2
2.2.1	Equipment Location/ Environment	2-2
2.2.2	Service Connections	2-3
2.2.3	Tools and Equipment	2-5

SECTION 3 OPERATION

3	Features	3-1
3.1	Operation Overview	3-1
3.2	Operator Console	3-2
3.2.1	Component Description	3-4
3.2.2	Operating Procedures	3-4
3.2.3	Remote Operation	3-4
3.3	Special Start-Up Procedures	3-5
3.3.1	Start-Up Following HP Maintenance	3-5
3.3.2	Initial Pump Start –Up Procedure	3-5
3.3.3	Pump Operation	3-7
3.3.4	Hydraulic Pump Pressure Compensator Adjustment Procedure	3-10
3.4	Shutdown Procedure	3-11
3.4.1	Normal Shutdown Procedure	3-11
3.4.2	Emergency Shutdown Procedure	3-11
3.4.3	Remote E-Stop Provisions	3-11
3.5	Fault Messages Overview	3-11
3.5.1	High Oil Temperature Shutdown	3-11
3.5.2	Low Oil Level Shutdown	3-12

SECTION 4 MAINTENANCE

4	Maintenance	4-1
---	-------------	-----

4.1	Scheduled Maintenance	4-3
4.2	General Maintenance	4-3
SECTION 5 TROUBLESHOOTING		
5	Troubleshooting	5-1
SECTION 6 LOW PRESSURE WATER SYSTEM		
6	Features	6-1
6.1	Oil Cooling Water Supply	6-1
6.2	Cutting Water Supply	6-2
6.2.1	Normal Operating Condition	6-2
6.2.2	Operation	6-2
6.2.4	Low Pressure System Protection	6-3
6.3	Maintenance Overview	6-3
6.3.1	Water Filter Service	6-3
SECTION 7 HIGH PRESSURE WATER SYSTEM		
7	High Pressure (HP) Water	7-1
7.1	Components	7-1
7.2	Intensifier Disassembly and Reassembly	7-2
7.2.1	HP & LP Water Piping	7-3
7.2.2	HP Sealing Head	7-4
7.2.3	HP Cylinder	7-6
7.2.4	Hydraulic Seal Cartridge & Plunger	7-8
7.2.5	Hydraulic Cylinder Head & Hydraulic Piston	7-10
7.3	Intensifier Subassemblies Inspection & Repair	7-12
7.3.1	Discharge HP Check Valve	7-13
7.3.2	Inlet Check Valve	7-15
7.3.3	Sealing Head	7-16
7.3.4	HP Cylinder	7-17
7.3.5	Plunger	7-18
7.3.6	Hydraulic Seal Cartridge	7-19
7.3.7	Hydraulic Piston	7-21
7.3.8	Hydraulic Cylinder	7-15
7.4	HP Dump Valve	7-26
7.5	HP Attenuator	7-26
SECTION 8 ELECTRICAL SYSTEM		
8	Features	8-1
8.1	Electrical Overview	8-1
8.1.1	Motor Starter Circuit	8-1
8.1.2	Control Circuits and Logic	8-1
8.1.3	Operation	8-2
8.2	Maintenance Overview	8-4
8.2.1	Proximity Switch Service	8-4
SECTION 9 HYDRAULIC SYSTEM		
9	Hydraulic System	9-1
9.1	Overview	9-1
9.1.1	Features	9-1
9.1.2	Components	9-2
9.2	Operation	9-3
9.2.1	Hydraulic Pressure Compensation	9-3
9.2.2	Hydraulic System Pressure Protection	9-3
9.2.3	Motor Startup	9-4

9.3	Motor/ Hydraulic Service Maintenance	9-4
9.3.1	Pump Compensator Adjustment	9-4
9.3.2	Pump /Motor Coupling Service	9-6
9.4	Pump Service	9-6
9.4.1	Pump Case Prefill	9-6
9.4.2	Seal Kits	9-6
SECTION 10 RECIRCULATION SYSTEM		
10	Features	10-1
10.1	Components	10-1
10.2	Operation	10-1
10.3	System Pressure Protection	10-2
10.4	Maintenance Overview	10-3
SECTION 11 SPECIFICATIONS		
11	Specifications	11-1
	Equipment Specifications	11-1
	Torque Specifications	11-3
	Cutting Water Specifications	11-4
	Cooling Water Specifications	11-4
	Orifice Support Capacity	11-5
SECTION 12 PARTS LISTS		
12	Parts Lists	12-1
	Hydraulic Schematic Diagram	
	Electrical Schematic Diagram	

Section 1 INTRODUCTION**1 SL-IV 11 kW (15 hp) Waterjet Pump General Information**

The Streamline SL-IV 11 kW (15 hp) Waterjet Pump, maintains the level of component reliability and ease of installation and maintenance that have made the KMT Waterjet Streamline waterjet pumps the standard of the industry for both water and Hydroabrasive™ applications.

The SL-IV 11 kW (15 hp) Waterjet Pump uses low pressure water, which meets certain quality requirements, and increases the pressure up to 3,800 bar (55,000 psi) for ultra-high-pressure waterjet cutting, hydroabrasive cutting, cleaning, surface preparation, etc.

This manual provides information for installation, operation, and maintenance of the KMT Waterjet SL-IV 11 kW (15 hp) Waterjet Pump.

1.1 Physical Description

The SL-IV waterjet pump is equipped with a hydraulic intensifier, a high pressure attenuator, a motor/hydraulic pump assembly, an electric starter panel, control sensors, solenoids and logic, control interface panel, and a low pressure water filter.

Letter	Dimension	
	mm	inch
G	140	5.50
H	203	8.00
J	267	10.50
K	419	16.50
L	400	15.75
M	483	19.00
N	554	21.82
P	33	1.31
R	832	32.78
S	1422	56.00
T	711	28.00

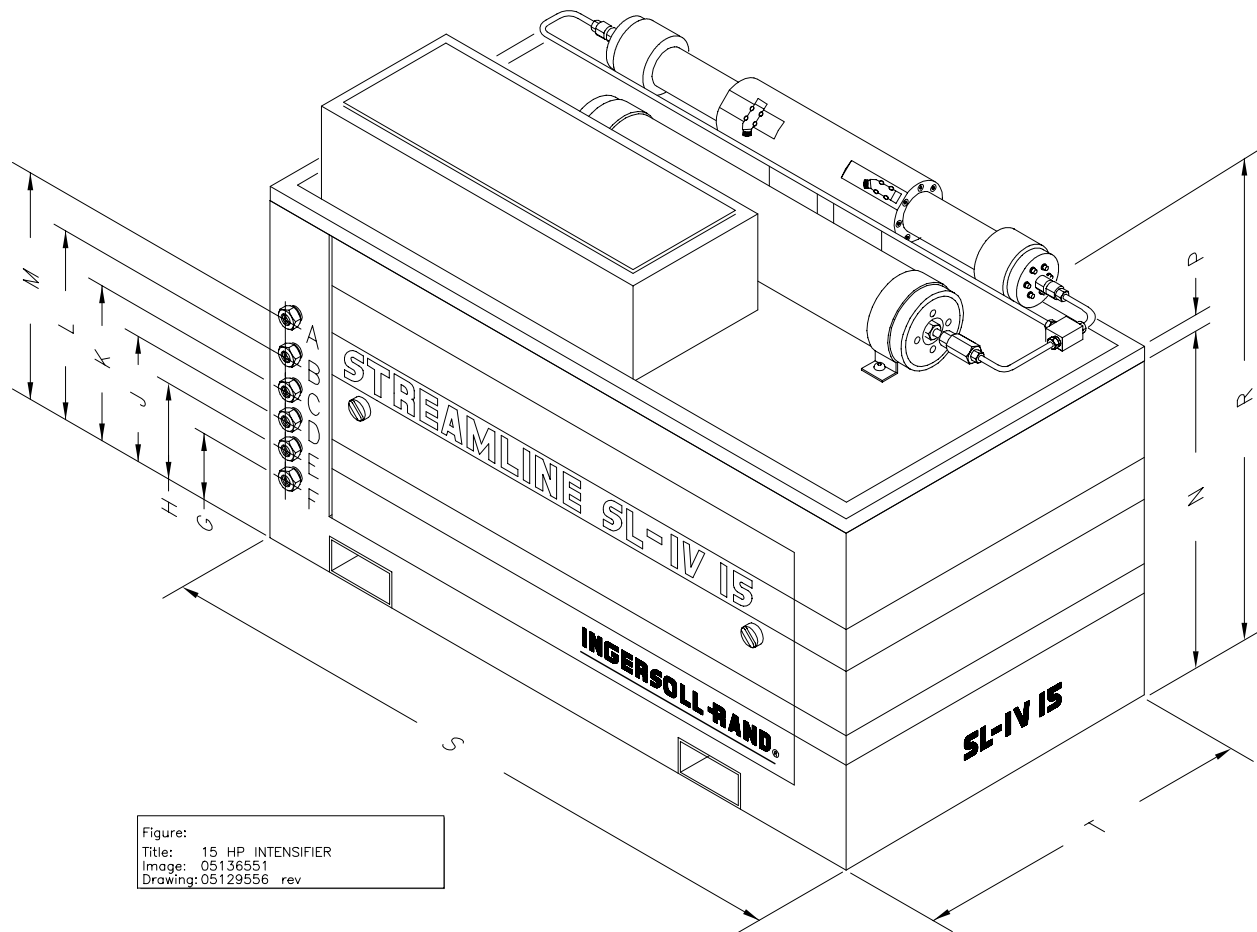

Figure:
Title: 15 HP INTENSIFIER
Image: 05136551
Drawing: 05129556 rev

The SL-IV11kW (15hp) Waterjet pump is enclosed in a frame with the dimensions of 56" length, 28" width, and 32.8" height. The high pressure system is conveniently mounted on a drip pan. All service components are easily accessible from at least two sides simplifying maintenance. The entire high pressure system can be removed from the rest of the unit quickly for maintenance and serviceability.

1.1.1 Standard Equipment

Following is an overview of the standard equipment for the SL-IV 11 kW (15 hp) waterjet Pump:

- Variable displacement, pressure compensated hydraulic pump
- Filtration system with 10-micron filter
- High efficiency heat exchanger in independent recirculation pump circuit
- Stand-alone unit with built-in Wye-Delta motor starter
- High pressure safety dump valve
- High pressure attenuator
- Microprocessor control with diagnostic capability
- Separate water and oil drip pans
- Electrical remote control interface

1.2 Functional Description

The SL-IV 11 kW (15 hp) Waterjet Pump meets the automotive and industrial markets needs of low to high volume production of water jet pumps. The maximum HP water pressure is limited by a hydraulic relief valve that is certified and sealed by TUV. No HP rupture disk is required.

The HP intensifier is a reciprocating, double-ended hydraulic operated, electrically shifted hydraulic piston type. The HP intensifier produces water flow at high pressure, while the HP attenuator reduces the routine fluctuations in the HP water pressure signal. The compression ratio is 20:1 with a maximum hydraulic pressure set at 214 bar (3,100 psi).

The recirculation hydraulic loop for cooling and filtering oil runs continuously whenever the motor is running.

1.2.1 Functional Features

Following is a list of SL-IV 11 kW (15 hp) Waterjet Pump features:

- 4,150 bar (60,000 psi) design pressure
- 3,800 bar (55,000 psi) operating pressure
- Electronic reversing of intensifier piston
- 24vdc control wiring
- Exclusive long slow stroke
- Cartridge type hydraulic seal for easy plunger service
- Low pressure filtration
- Reduced cooling water requirements
- Meets CE requirements

1.3 Worldwide Product Support

The KMT Waterjet Service Department serves the customer, by providing:

Supervision of equipment installation, start up, and training for the number of days specified in the quotation, and per approved project. Additional time requested will be invoiced on a per diem basis, plus travel and normal living expenses.

Field Services: on-site technical support is available on request. These services are invoiced on a per diem basis, plus travel, and normal living expenses.

Technical Assistance: the Service Department is available for technical assistance by phone.

Training: the Service Department conducts periodic training sessions at KMT Waterjet designated training locations. On-site training is also available.

1.3.1 Service Department

To contact the KMT Waterjet Service Department:

USA:Service Manager
KMT
Waterjet Systems
635 West 12th Street
Baxter Springs, KS 66713
USA
Phone: (620) 856-2151
Fax: (620) 856-5050

Europe:Technical Manager
KMT Waterjet GmbH
Wasserstrahl-Schneidetechnik
Auf der Laukert 11
D-61231 Bad Nauheim
Germany
Phone: 49-(0)6032-997-117
Fax: 49-(0)6032-997-270

1.3.2 Spare Parts

KMT Waterjet maintains a well stocked Spare Parts Department staffed by well trained knowledgeable personnel. Emergency shipment is available.

Contact the Service Department of KMT Waterjet Systems.

1.3.3 Questionnaire

The following equipment and service manual questionnaire will provide information to allow us to serve you better. Please complete them at your convenience and return to the applicable Service Department as shown above.

EQUIPMENT AND SERVICE MANUAL QUESTIONNAIRE

We have just installed a new SL-IV 11 kW (15 hp) Waterjet Pump at your location. We are interested in your initial impressions of the unit and its installation. Please take a few moments and answer the following questions.

General Appearance

Was unit received in good condition?

 Yes No

Comments: _____

Is the unit a convenient size?

 Yes No

1. Controls

a. Are the controls user friendly?

 Yes No

b. Is the unit easy to operate?

 Yes No

Comments: _____

2. Performance

a. Does the unit perform smoothly and meet your expectations?

 Yes No

b. Does the unit run quietly?

 Yes No

Comments: _____

3. Did installation and start-up go smoothly?

 Yes No

Comments: _____

4. What feature(s) do you consider the most significant with this unit?

Quiet Operation _____

Appearance _____

Performance (Operation) _____

Repair/Maintenance _____

Other _____

5. What areas need improvement?

Appearance _____

Servicability _____

Performance _____

Other _____

Manual Organization

1. Does the table of contents help you find topics easily? Yes No

Comments: _____

2. Is the information well organized? Yes No

Comments: _____

3. Is the page layout suitable for the material being presented? Yes No

Comments: _____

Graphics

1. How do you rate the quality and quantity of the photos/illustrations? Yes No

Comments: _____

Text

1. Does the information in the manual adequately explain how to operate and service the equipment? Yes No

Comments: _____

2. Are there paragraphs or procedures you feel need clarification? Please identify them by page number and add your comments. Yes No

Comments: _____

3. Is there anything you would add or delete from the manual to make it more useful? Yes No

Comments: _____

4. Is there any information that should receive more emphasis? Yes No

Comments: _____

Name: _____ Title: _____

Company _____















Address: _____

1.4 Safety

Safety procedures and safe practices must be followed during installation, operation, and maintenance of the waterjet pump. In this section we have provided label and sign descriptions used in this manual, as well as recommended safety procedures.

1.4.1 Labels and Abbreviations

The following describes hazard classifications of the waterjet pump.

 CAUTION	Indicates the presence of a hazard that can cause personal injury, or property damage if the caution instruction is ignored.
 WARNING	Indicates the presence of a hazard that can cause severe personal injury, death, or substantial property damage if the warning instruction is ignored.
	High pressure waterjet can cause eye injury. Wear eye protection when operating or working near machine.
	Hazardous noise can cause hearing loss. Wear ear protection when operating or working near machine.
	Hazardous voltage within can cause injury or death. Disconnect and lockout main power before opening cabinet.
	Malfunction
	Hydraulic Intensifiers
	Pressure Control
	High Pressure
	Low Pressure
	Start/Control Power On
	Stop
	Run
	Local/Remote Control

Rear of Waterjet Pump

A	HP Water "OUT"
B	Plant Air "IN"
C	Cooling Water "IN"
D	Cooling Water "OUT"
E	" Cutting Water "IN"
F	Drain

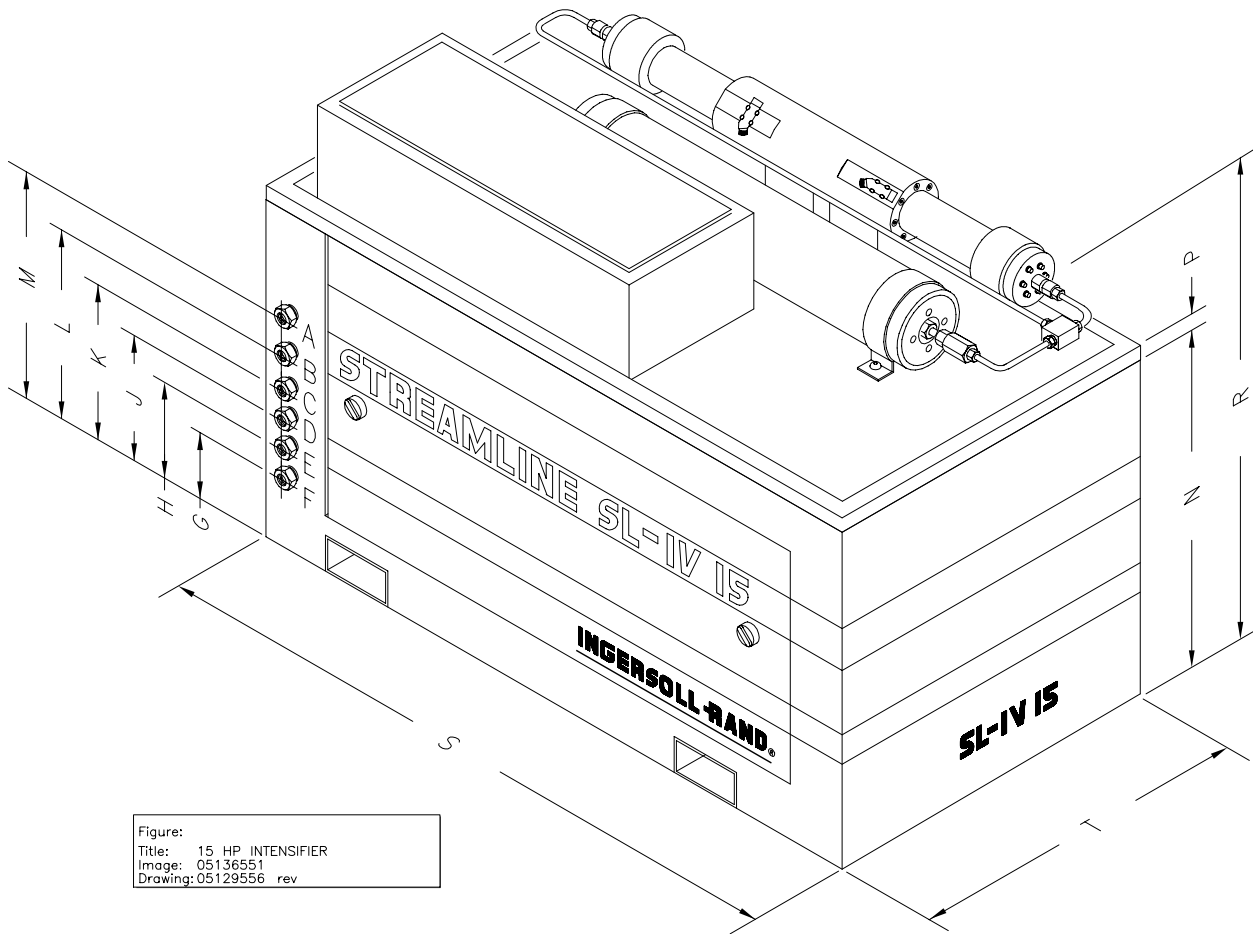

Figure:
Title: 15 HP INTENSIFIER
Image: 05136551
Drawing: 05129556 rev

The following figure shows other safety labels or icons used on the SL-IV waterjet pump. Trapped HP water or oil warning warns against the hazard of trapped HP water or hydraulic pressure after the pump has been shut off. Typically all pressure can be safely bled off if the operator will leave the HP cutting water valve open for a few seconds after shutting off the pump.

Electrical shock hazard warns of electrical shock hazard when in the vicinity of the electrical enclosure or motor junction box. Hot surface warning warns of hot surfaces on the HP water and hydraulic components while the pump is in normal operation.

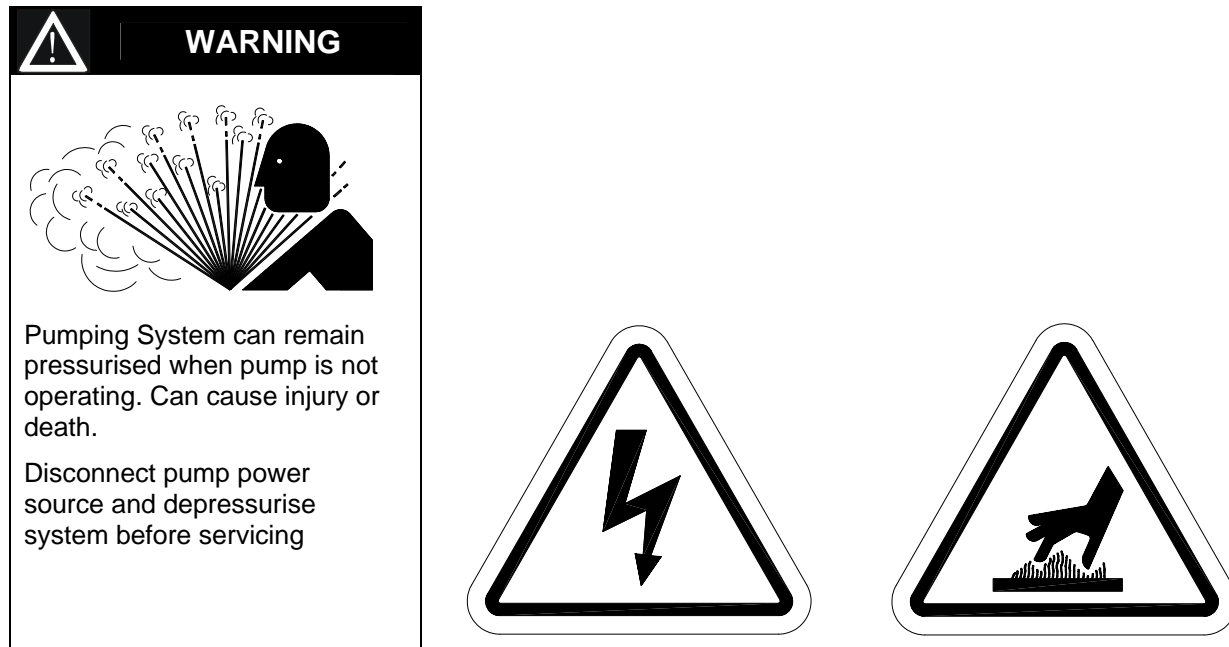

Figure 1-1. Other Safety Labels & Icons Used on the SL-IV Waterjet Pump
 (a) Trapped HP Water or Hydraulic Oil (b) Electrical Shock Hazard (c) Hot Surface Warning

1.4.2 Safety Procedures

Safety procedures must be observed while working on the pump, or any high pressure part of the installation. **Service should only be performed by qualified personnel.**

- The high pressure water, 3,800 bar (55,000 psi) in waterjet cutting systems should not be a cause for concern. Users must have due respect for these pressures and use proper SAFETY PROCEDURES and SAFE WORK HABITS.
- Everyone associated with the waterjet cutting system must realize that the force of the waterjet cutting stream can penetrate many dense or strong materials.
- Keep all untrained people away from the waterjet cutting area. Use barriers or partitions if needed.
- Safety glasses must be worn at all times in the waterjet cutting area.
- All **EMERGENCY STOP** buttons must be checked periodically. The normal operating position is pulled out.
- To check: turn on power and activate the **EMERGENCY STOP** buttons by pushing them in to see if the power goes off. Each device should be checked on a specified schedule. Each time the device is checked, it must function or be replaced before operating the system.
- Apply High Purity Goop (P/N 10084440) to all threaded high pressure connections. All tubing, fittings and bolted connections should be torqued to recommended values. Do NOT attempt to tighten or loosen a HP water fitting when the circuit is pressurized, see High Pressure (HP) Piping Safety.

- All high pressure leaks must be repaired immediately.
- Inspect all equipment on a scheduled basis.
- Before performing any maintenance on the unit, **MECHANICALLY LOCK THE MAIN CONTROL POWER OFF**, and assure the high pressure has been bled off.



Never do any work on the unit without making sure the electrical panel disconnect is locked out with a padlock in the OFF position, and that the proper tagout procedure has been implemented.



Never work on any high-pressure component, or loosen any high-pressure fitting without first bleeding the system and assuring there is no high-pressure water present.



Make sure the safety devices are operational. To panic stop the pump and bleed the high-pressure, an **EMERGENCY STOP** button must be pushed in while the system is active. The intensifier high-pressure dump valve will automatically open to bleed off the stored pressure.



Do not attempt to touch the waterjet stream, or contact the high-pressure water. The high-pressure water will penetrate all parts of human body without exception.



The liquid stream or material ejected by these extreme pressures can injure or kill.

1.4.3 High Pressure (HP) Piping Safety

High pressure piping must be installed without torsional or bending stresses. Proper supports and guides must be provided. 9/16" outside diameter HP tubing and fittings are recommended between the pump and the cutting station. This large tubing size will reduce vibration, strain and motion between the pump piping and the cutting area. The larger piping diameter also reduces pressure drop, and pressure pulsation.



Do not try to repair a leak in a HP water fitting when it is pressurized. Always shut off the power and bleed the HP water before doing maintenance on HP components. Weep holes are provided to release HP water if leakage occurs at a sealing surface. If a fitting is loosened with HP water present, a jet of HP water will exit the nearest weep hole with **possible hazardous results**.



Use extreme caution when handling high-pressure equipment. Possible failure from fatigue cracking or over-pressurization can result in a hazardous high-pressure leak, or component failure.



A flexible ¼" HP tube (whip) is frequently used on the cutting system to allow cutting nozzle movement. Supports and guides for the whip must be used, anti-vibration fittings and proper support must be provided to prevent failures from external loads (non-water related stresses). The whip will only flex in a single plane without being subjected to torsional stress. Torsional flexing will precipitate tubing failure. To prevent torsional stress, the use of high-pressure swivels is strongly recommended. To prolong swivel life the whip must pass through rigid support bearing blocks to prevent side-loading of the swivel spindle.



When tightening or loosening HP connections, always use a supporting wrench to avoid bending forces or stress on the connection. Do not exceed recommended torque values



High-pressure piping and fittings designed to 4,100 bar (60,000 psi) must always be used. Failure to do so may lead to catastrophic component failure, which can cause equipment damage, injury or even death.

1.4.4 Emergency Medical Treatment

An information card to aid treating a waterjet injury is included in the binder of each manual. The card is shown below. Contact the address shown for additional cards.

Medical Alert

"This person has been working with water jetting at pressures to 55,000 psi (374MPa, 3740 bar, 3867 Kg/cm²) with a jet velocity of 3,000 fps (914 mps). Foreign material (sand) may have been injected with water. Unusual infections with microaerophilic organisms occurring at lower temperatures have been reported, such as gram negative pathogens as are found in sewage. Bacterial swabs and blood cultures may therefore be helpful. This injury must be treated as an acute surgical emergency and be evaluated by a qualified surgeon. Circulation may be compromised, therefore, **DO NOT APPLY HEAT TO INJURED PART**. For first aid: (1) Elevate injured part (2) Antibiotics (3) Keep injured person NPO."

Section 2 EQUIPMENT INSTALLATION**2 Installation**

The installation, start-up, operation, and maintenance of the SL-IV Waterjet Pump requires complete reading and study of this manual to understand the system in detail.

2.1 Installation Overview

Read the manual and become familiar with the operation of each component and its nomenclature.

Understand the complete system and its function before operating it.

Safety procedures and safe practices must be followed during installation, operation, and maintenance of the SL-IV Waterjet Pump.

2.1.1 Buyer Obligations

Equipment installation requires cooperation between the user and KMT Waterjet. If on-site support is requested, the KMT Waterjet Service Department will require the following tasks be accomplished before arrival at the customer site:

- The waterjet cutting equipment should be uncrated, positioned and leveled, with electrical and fluid services brought to the unit.
- Provide and install power drops with fused disconnects sized to the equipment power requirements.
- Provide and install pneumatic drops with manual shutoff valves.
- Provide all mounting and support brackets and hardware for high pressure tubing runs.
- Provide and install water conditioning equipment necessary to meet water purity requirements. Provide and install manual shutoff valves.
- Provide and install necessary cooling water inlet/outlet, and drain water connections to the intensifier pump, and/or cutting equipment and manual shut-off valves.
- Provide suitably located and sized drains and proper disposal of waste water.
- Provide, install and connect wiring between the intensifier pumps, and the cutting station control system.
- KMT Waterjet supplies a pre-filled hydraulic system. If fluid is low or empty due to leakage during transit, the system must be filled per specifications.

2.1.2 Seller Obligations

If KMT Waterjet is requested, the following tasks will be the responsibility of the KMT Waterjet technician at installation.

- Insure site preparation is satisfactory.
- Remove internal strapping and blocking material.
- Insure that power is connected prior to equipment turn on.
- Insure that connections have been made for water and pneumatic service.
- Test motor rotation direction and correct if necessary.
- Power up and check out pump for proper operation.
- Set booster pump discharge pressure.
- Perform Leak check on high pressure plumbing.
- Follow the standard test procedure to insure satisfactory performance.
- Train maintenance personnel in the performance of maintenance and repair procedures.

2.2 Installation Requirements (Utilities)

Environment: The SL-IV Waterjet Pump must be installed indoors. Ambient conditions must not exceed maximum specifications.

Moving: The SL-IV Waterjet Pump has provisions to be moved with a forklift. Check weight specifications.

**CAUTION**

The waterjet pump is top heavy. Avoid situations that could result in the equipment tipping or overturning.

**WARNING**

Electrical connections must be made by qualified personnel, and must meet national and local electrical codes.

2.2.1 Equipment Location/Environment

Space Requirements:

There should be a minimum of 900mm (36 inches) clearance on all sides of the pump to facilitate service.

Electrical Wiring:

Power supplied to the pump must be in accordance with national and local electrical codes. See specifications or requirements.

Insure that the service voltage and ampacity are proper for this SL-IV Pump. Voltage fluctuations in excess of +/- ten percent of nominal voltage may damage the SL-IV Pump. Refer to Section 11, "**Specifications**".

Control Wiring:

Wiring for remote control of the pump must be in accordance with national and local electrical codes. The SL-IV Waterjet Pump has a 24vdc electrical control system and has provisions for remote operation in the pump control panel.

2.2.2 Service Connections**Cooling Water IN/OUT:**

Supply piping must be properly sized to handle the necessary flow, and pressure. Piping must meet national and local piping codes.

If municipal or well water is used for cooling, insure that the supply will flow a minimum of 1 gallon per minute at a minimum of 30 PSIG under maximum usage conditions.

If a plant chilled water system is used for cooling, insure that there is a minimum of 30 PSIG pressure differential between the facility supply and discharge plumbing. Installation of an in-line pressure boosting pump may be necessary to provide adequate cooling flow.

Cutting Water IN:

Supply piping must be properly sized to handle the necessary flow and pressure. Piping must meet national and local piping codes.

Prior to operation, insure that the cutting water meets minimum standards listed in Section 11 “**Specifications**”. Operation without proper water quality will shorten the life of certain intensifier parts and void their warranty.

Use only plastic or copper plumbing from the cutting water source to the SL-IV pump cutting water supply filter.

Thoroughly purge the cutting water supply plumbing prior to connecting to the SL-IV pump.

HP Water OUT:

Properly rated, sized, and well supported high pressure (HP) piping must be connected to the pump.

If new HP discharge piping is installed, all burrs that might come loose must be carefully removed, and the tubing sections should be purged with compressed air prior to assembly. Further, it is strongly recommended that the HP piping be purged under high pressure operating conditions, using a large, cheap orifice. Contamination from the HP piping will be released when the tubing expands under pressure. If the HP piping is not purged, expect to have early orifice failures.

All stainless steel parts should have High Purity Goop (P/N 10084440) applied to the treads and contact surfaces prior to assembly. Do NOT USE ANY OTHER ANTI-SEIZE COMPOUND. Failure to use High Purity Goop will result in galling of the parts, and will generally render them unusable. Do not use HIGH PURITY Goop on ANYTHING but stainless steel!

Drain:

Cutting water released in the pump is discharged from the drain port and must be piped to an appropriate location (i.e. sewer line). Piping must meet national and local piping codes.

Compressed Air:

The facility air connection to the SL-IV Pump should provide clean, dry air at 5.9 bar (85 psig). Air usage is minimal, that is, far less than 1 SCFM.

Rear of Waterjet Pump

A	HP Water "OUT"
B	Plant Air "IN"
C	Cooling Water "IN"
D	Cooling Water "OUT"
E	" Cutting Water "IN"
F	Drain

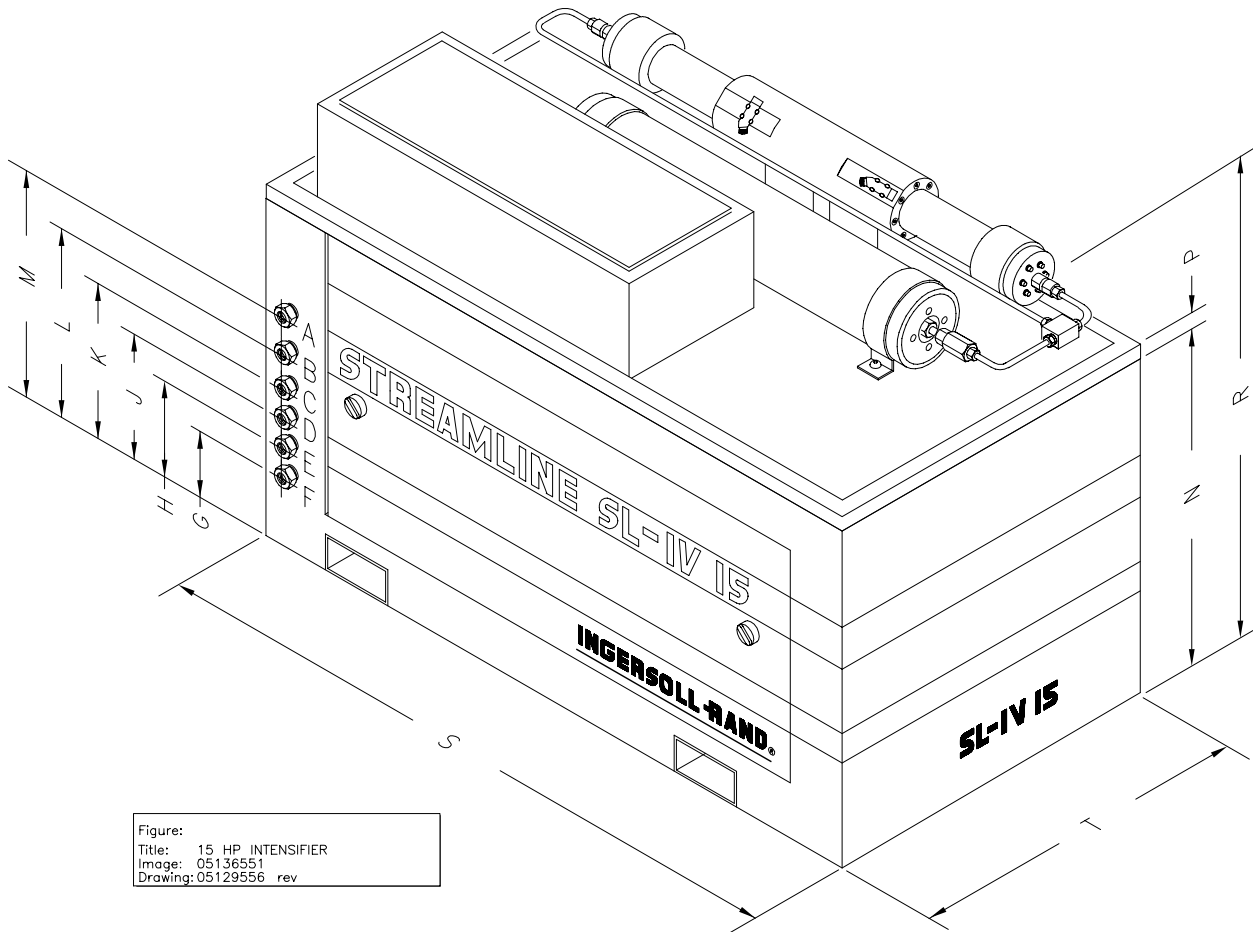

Figure:
Title: 15 HP INTENSIFIER
Image: 05136551
Drawing: 05129556 rev

2.2.3 Tools and Equipment

2.2.3.1 HP Tube Coning and Threading Procedures

Determine Tube Length - Measure, the distance (L), between the fittings, then add two times the tube engagement length in the following table. Cut tubing to length and deburr.



High-pressure piping and fittings rated for 4,138 bar (60,000 psi) must be used. Failure to do so may cause component failure causing equipment damage, personal injury, or death.

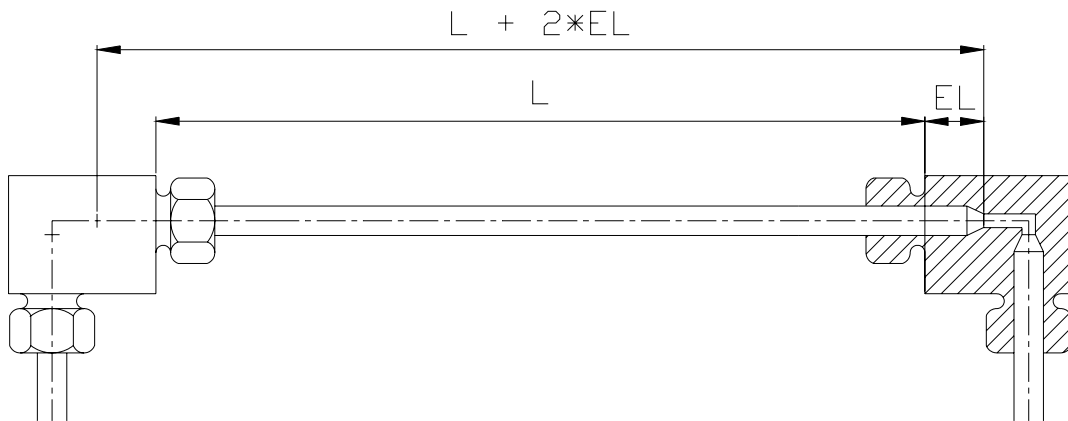

Tube Engagement Length

HP Tube Diameter (inch)	Engagement Length (EL) mm (inch)
1/4"	12.7 (0.50)
3/8"	17.5 (0.69)
9/16"	21.3 (0.84)

Cone and Thread Tube

Cone and thread both ends of the tube per following diagram and procedure.

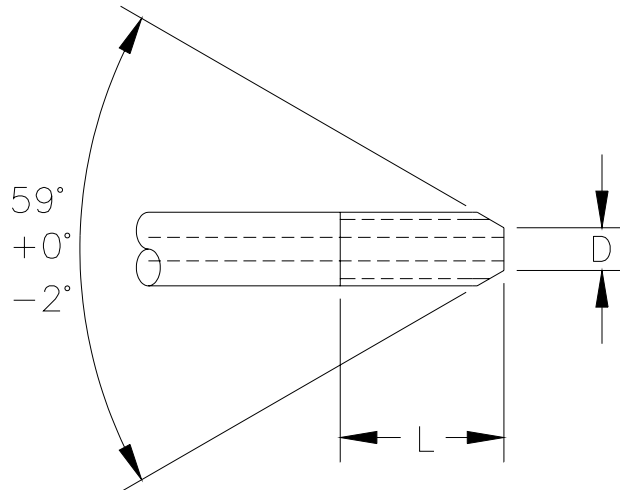

Cone and Thread Dimensions

O.D. Size mm (inch)	I.D. size mm (inch)	D (max) mm (inch)	L (max) mm (inch)	Thread NF-LH
6.35 (1/4")	2.11 (0.083)	3.58 (0.141)	14.3 (0.562)	(1/4"- 28)
9.52 (3/8")	3.18 (0.125)	5.56 (0.219)	19.1 (0.750)	(3/8"- 24)
14.27 (9/16")	4.78 (0.188)	7.14 (0.281)	23.8 (0.938)	(9/16"- 18)

To cone the tubing, use the following figure as reference.

Cone and Threading Tool

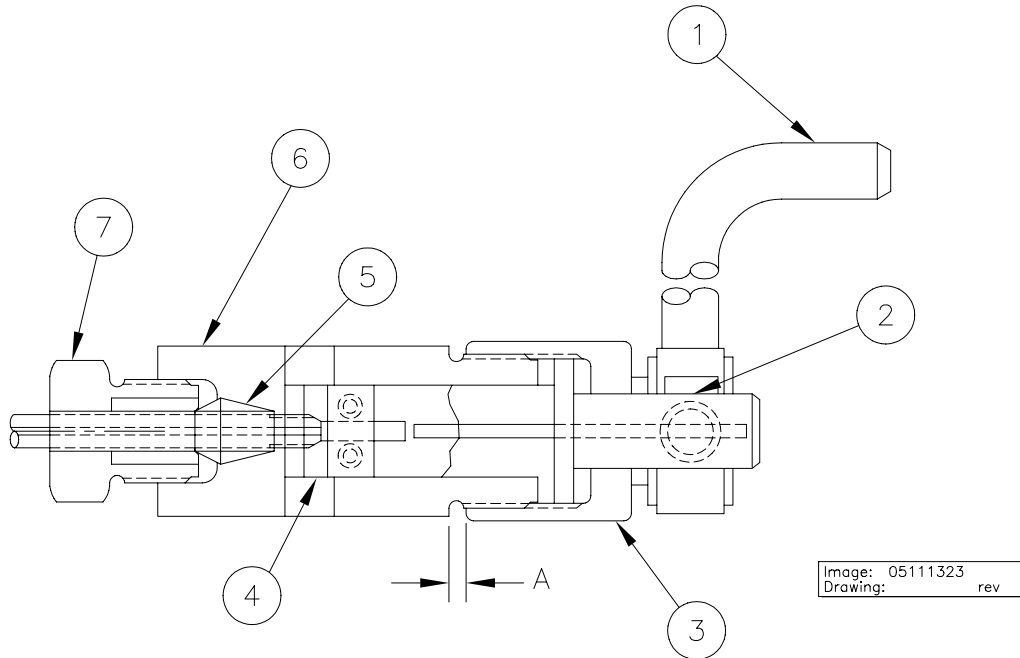

Item Description

- (1) Cutter Handle (2) Cutter Support (3) Feed Nut
 (4) Cutting Blades (5) Collet (6) Housing (7) Gland Nut

Tube Size (inch)	1/4"	3/8"	9/16"
A mm (inch)	3.30 (0.13)	4.07 (0.16)	7.11 (0.28)
Coning Tool (Part)	10079556	10097418	10079663
Threading Tool (Part)	10079697	10097434	10097442

Coning

- Place appropriate size coning tool in vise so that lubricant can flow to cutting blades (4).
- Set feed nut (3) location as shown in dimension A.
- Slide tubing through collet (5) until end contacts cutting blades (4) and tighten gland nut (7) just enough to slightly grip tubing.
- Turn feed nut (3) counterclockwise to back cutters away from tubing, and tighten gland nut (7) with wrench.
- Apply cutting oil through coning tool opening. A medium weight cutting oil having high sulfur content is recommended. Use cutting oil freely throughout the cutting operation.
- Turn feed nut (3) clockwise until cutting blades (4) contact end of tubing.
- Rotate cutter handle (1) in clockwise direction while simultaneously turning the feed nut (3) in a clockwise direction at a rate to assure that the cutting blades (4) are taking a light cut at all times.
- Continue rotating cutter handle until feed nut bottoms on housing (6), then rotate cutter handle several more revolutions to face-off end of cone.
- Unscrew feed nut (3), and remove the blade spindle (2) from the coning tool. Loosen the collet, slide the tubing (8) into the housing (6) until it extends approximately 100mm (4 inches) then retighten collet.

Threading

Place appropriate size threading tool on coned end of tubing, apply pressure to start cutting action and rotate die holder counterclockwise until threads are cut per cone and thread dimension table.

HP Tube End Connection - Regular

The following type of connection is for general applications, where the only load on tubing is due to internal pressure.

1. Slip gland nut (2) on tubing (1) as shown and lubricate thread with High Purity Goop. Thread collar (3) on tubing until one to two threads are exposed between collar item (3) and tube cone.
2. Lubricate male threads of gland with High Purity Goop. Insert tubing in fitting, engage gland nut and tighten finger-tight.
3. Tighten gland to specified torque as given in the torque table specifications.

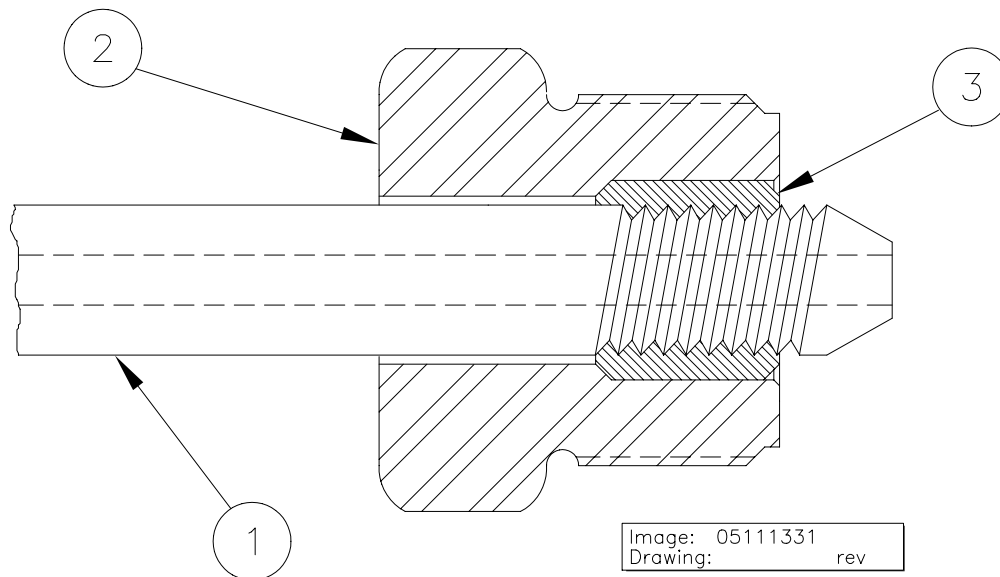

HP Tube End Connection - Antivibration

The following type of connection must be used when tubing is subjected to vibration, rotation, movement, and side loads (i.e. whip tubing). Lubricate threads as above.

**WARNING**

Do not depend on end connection to take the tubing load alone. Proper piping support and guide must be provided.

**WARNING**

Do not subject the tubing to torsional (rotational) stress. To do so will cause premature failure.

1. Slip gland nut (2) and collet (4) on tubing (1), thread collar (3) until one to two threads are exposed between collar and tube cone.
2. Lubricate male threads of gland nut with High Purity Goop. Insert tubing in fitting, engage gland nut and finger tighten.
3. Tighten gland nut to the specified torque according to the table of Recommended Torque Values in this section.

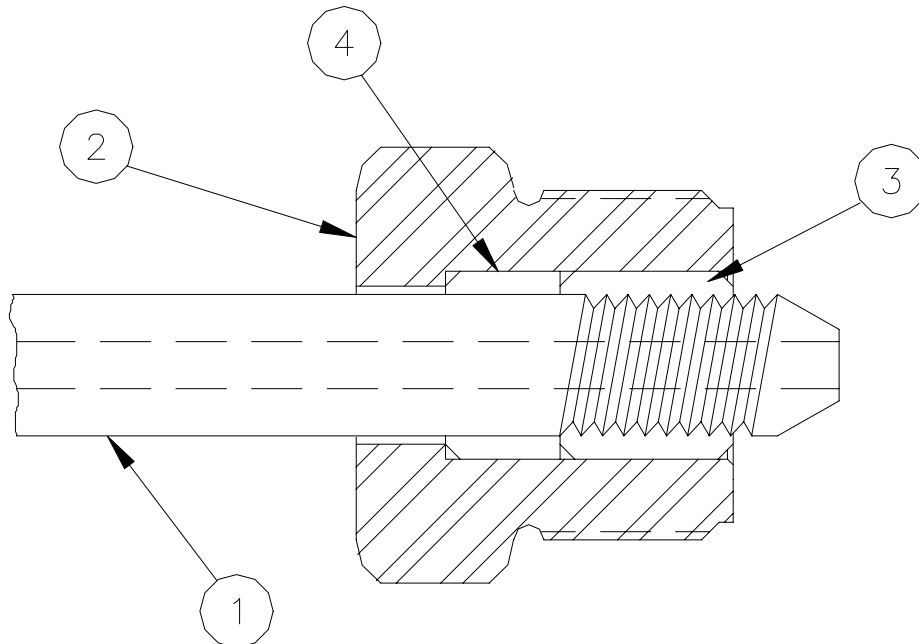

Section 3 OPERATION

3 Features

The SL-IV 11 kW (15hp) Waterjet Pump is composed of the following systems:

- Low Pressure Water System
- High Pressure Water System
- Hydraulic System
- Recirculation System
- Electrical System

3.1 Operation Overview

The I-R SL-IV Waterjet Pump can be started and stopped from either the pump-mounted controls or from (optional) remote controls located at or near the cutting system operator’s console.

The following provides the component overview:

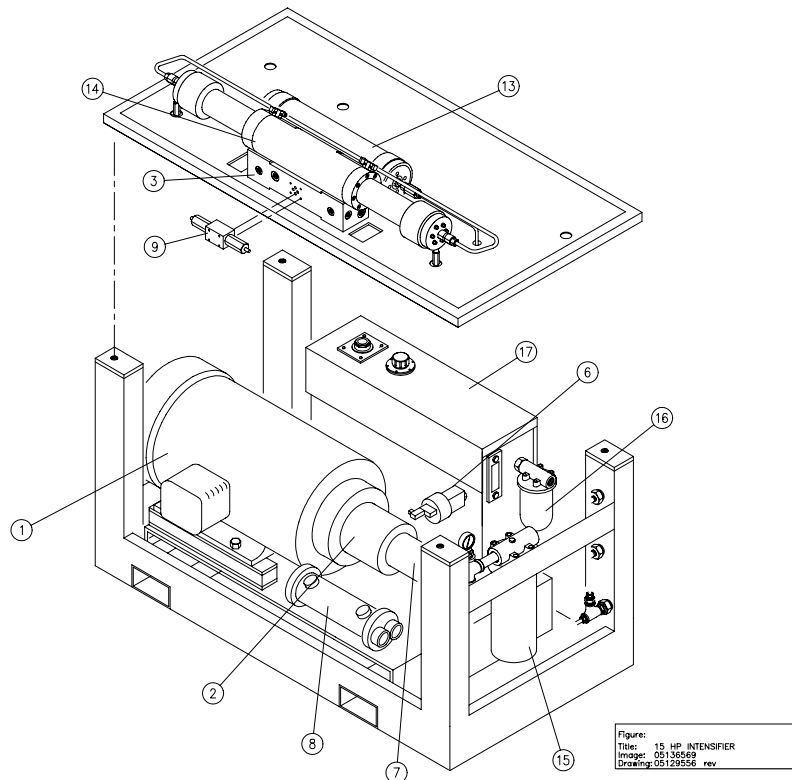

Figure:
Title: 15 HP INTENSIFIER
Image: 05132519
Drawing: 05129556 rev

Item Description

1 Electric Motor	Pump	15 LP Water Filter
2 Hydraulic Pump	8 Heat Exchanger	16 Oil Filter
3 Manifold	9 Directional Control Valve	17 Reservoir
6 Solenoid Shutoff Valve	13 HP Attenuator	
7 Hydraulic Gear	14 Intensifier	

3.2 Operator Console

Operator interface with the SL-IV Waterjet Pump is through the operator's panel. The panel consists of the emergency stop (E-Stop) palm button START, STOP, control power RESET pushbuttons, and indicator lights.

All electrical power to the SL-IV pump passes through the main disconnect, controlled by the panel disconnect handle on the enclosure.

The following shows the layout of buttons and lights of the operator's console for the waterjet pump.

3.2.1 Component Description

- **CONTROL POWER ON (Item 3):** White Lighted Pushbutton. After pulling out the E-STOP, press the CONTROL POWER ON button to power up the operator's console. When the white CONTROL POWER ON light is lit the 24vdc control power is ON, and the pump can be started.
- **Emergency Stop (E-STOP) (Item 1):** Push in to stop pump. The E-STOP button causes the following actions:
 - Electrical control power is shut off and the electric motor, hydraulic pumps and intensifier assembly stop.
 - The high pressure (HP) dump valve is opened. HP water is bled from the pump piping circuit.
 - To reset the E-STOP button, pull out.
 - For normal shutoff use the STOP button on keypad.
- **STOP (Item 7):** Stops the pump in all but emergency stop situations. Pressing the STOP button shuts off electric motor and hydraulic pump. Electric control power (24vdc) stays on.
- **START (Item 8):** Starts the pump, and generates high pressure.
- **RUN (Item 6):** Green light is ON when the pump is working normally.
- **PUMP PROBLEM (Item 5):** Red light is ON when the pump has stopped due to an abnormal condition. Blinking occurs during abnormal operation.
- **PANEL ELECTRICAL DISCONNECT HANDLE (Item 2):** Latches/ opens electrical enclosure. Rotating this latch to the OPEN position causes power to be disconnected from the motor circuit and from the control circuit. This handle arrangement is intended to remove power from the electrical circuits whenever the electrical enclosure door is opened.
- **LOCAL OR REMOTE SELECTOR SWITCH (KEYED) (Item 4):** Two position switch used to transfer control of SL-IV pump to either cutting station (remote) or SL-IV pump (local).

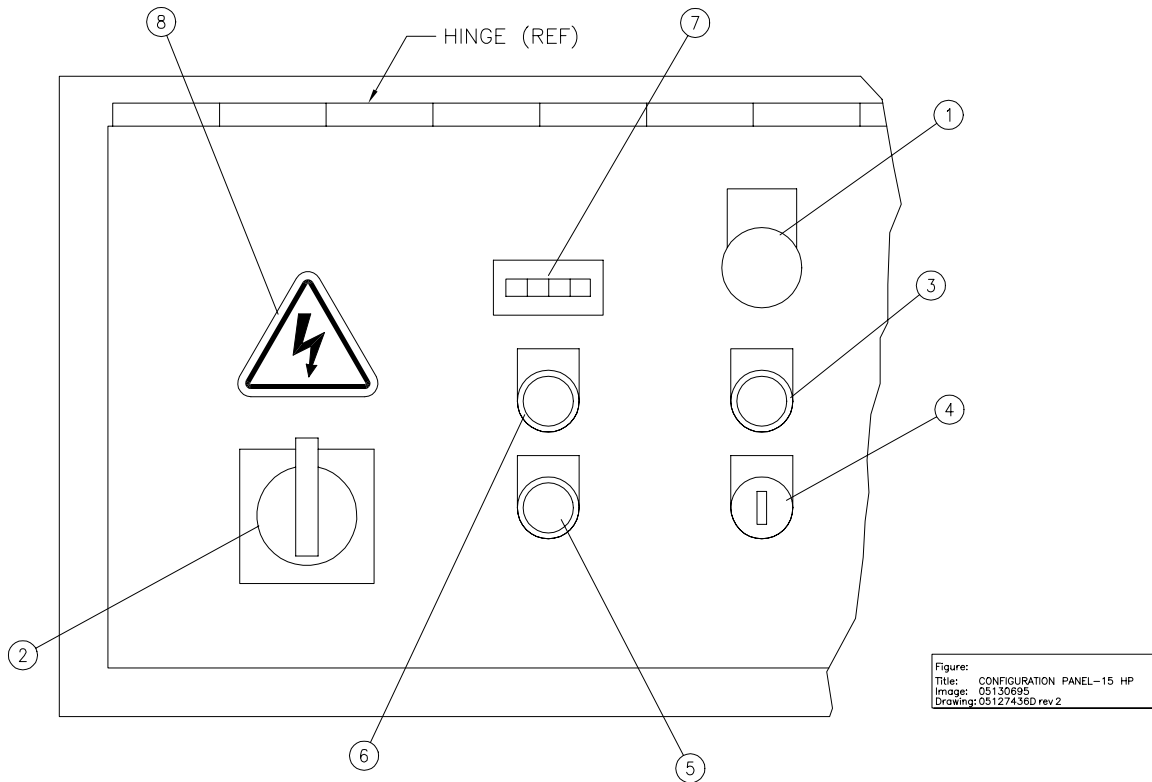
**Item Description**

- 1 Palmbutton – Emergency Stop
- 2 Handle – Electrical Disconnect
- 3 Pushbutton – (Control Power On—White Light)
- 4 Selector Switch-Local/Remote Control
- 5 Pushbutton – (Stop Pump/ Fault--Red Light)
- 6 Pushbutton – (Start Pump--Green Light)
- 7 Hourmeter
- 8 Decal—Shock Hazard

3.2.2 Operating Procedures

The lights on the operator's console provide information.

The following pages show start, stop and fault recovery procedures.

START PROCEDURE

1. Pull EMERGENCY STOP (E-STOP) palmbutton.
2. Push CONTROL POWER ON button. CONTROL POWER ON button light (WHITE) will be ON.
3. Push Green button – motor starts and after a delay pump starts.
CONTROL POWER ON light will be ON
RUN green light will be ON

STOP PROCEDURE

From the following conditions, follow the procedure below to stop the SL-IV pump:

RUN light (6) ON (Green)
CONTROL POWER light (3) ON (White)
SL-IV Pump Running

Push STOP button, RUN light (Green) will go OFF
CONTROL POWER ON light (White) will stay ON
SL-IV Pump will stop

3.2.3 Remote Operation

The waterjet pump is equipped with a REMOTE/LOCAL switch (4). The switch

transfers control from the local  panel (signified by symbol) to a remote

 panel (signified by the symbol).

The following list of functions can be wired remotely, but only the START is affected by the REMOTE/LOCAL switch.

- RUN (status light GREEN)
- Malfunction (status light RED)
- Start ^(P4)
- Stop ^(P4)
- Emergency stop

^(P4) Indicates that the remote function will not operate if the remote/local switch is in the local position. With the switch in remote position, these same two functions are disabled on the local panel.

3.3 Special Start-Up Procedures

3.3.1 Startup Following HP Maintenance

The following procedure should be used after intensifier HP component maintenance.

**CAUTION**

Failure to expel air from High Pressure (HP) internal passages following intensifier maintenance will cause damage to HP seals.

1. Electrical connector, HP water dump valve—**REMOVE** (temporarily) from solenoid valve.
2. Electrical power wall disconnect switch – **ON**
3. Emergency Stop (E-Stop) palm button—**LATCH**
4. Control power reset pushbutton—**DEPRESS**
RESULT: Electrical controls for SL-IV pump become energized.
5. Start switch —**ON**
RESULT: Intensifier will begin cycling, pumping water through the HP Dump Valve, thereby purging the HP cylinders of air and filling them with water.
6. Electrical connector, HP water dump valve—**RECONNECT**
7. Start switch —**ON**
Check for HP water leaks.
8. Verify normal HP water signal pattern and pressure level.
(This completes startup procedure following HP maintenance.)

3.3.2 Initial Pump Start Up Procedure

Make all connections for both electrical and water supply. Check the system for all correct connections before the unit is started for the first time. Assure safety standards have been observed. Following good safety practices will help avoid injury and damage to the pump.

Become familiar with this operation section, and understand the electrical lights and switch functions before attempting to operate this unit.

The following checklist should be reviewed before turning on the unit.

- Verify all interface connections have been made.
- Verify all safety circuits are connected and operational.
- Make sure the oil tank is full, check the sight glass located on the side of the tank. If oil is needed, remove cap and pump oil through fill port.

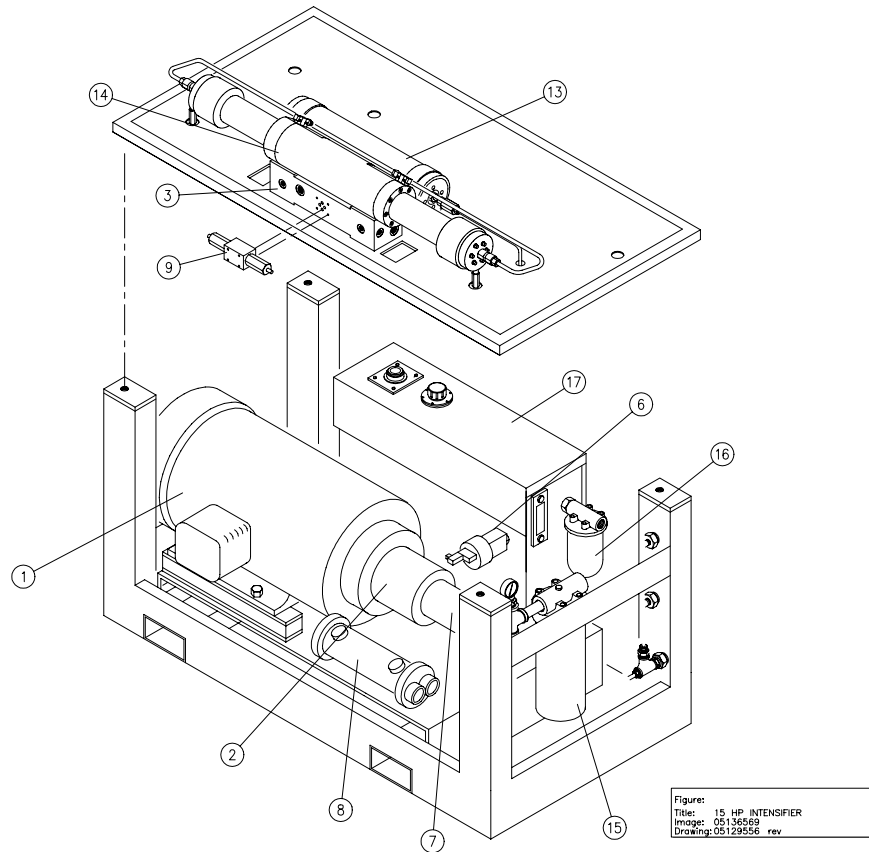

Item Description

1 Electric Motor	7 Hydraulic Gear Pump	13 HP Attenuator
2 Hydraulic Pump	8 Heat Exchanger	14 Intensifier
3 Manifold	9 Directional Control Valve	15 LP water Filter
6 Solenoid Shutoff Valve		16 Oil Filter
		17 Hydraulic Reservoir

- Insure all cooling water valves, supply water valves, and high pressure valves are open.
- Check direction of motor rotation (see arrow).



Do not run the motor backwards, as the hydraulic pump will likely be damaged.

Motor direction of rotation should be checked any time electrical maintenance/modification is performed on the motor starter wiring or on the service wiring to the pump.

Check that inlet cutting water is present before starting SL-IV Pump.

- At initial startup, run the intensifier at low pressure (refer to procedure in paragraph **3.3.4**) with an open valve in the HP piping system for two minutes. This procedure will eliminate trapped air in the high-pressure cylinders, which could become extremely hot when compressed. Trapped air will cause deterioration of HP seals.

To Check Motor Direction

1. Remove front cover from the SL-IV Pump to: 1) locate pressure gage on the hydraulic pump outlet port, and 2) view the motor fan.
Two methods for checking motor rotation are possible: 1) one person watches motor fan while a second person “jogs” motor, or 2) affix a plastic tie so that the loose end drags on the motor fan blades. “Jog” the motor START/STOP pushbuttons then observe motor direction of rotation from direction of plastic tie. Method No. 2 has the advantage that a second person is not required.
2. To jog motor, pull EMERGENCY STOP button on the control panel, and then press the CONTROL POWER ON button. With one person checking the direction of rotation, the other person can jog START and STOP pushbuttons. Jog the motor by using both hands on the control panel, one finger on the STOP button ready to shut off the motor as soon as the START button is pushed. It should be possible to jog the motor in a START-STOP action that lasts less than one second.

Note that if the motor rotates in the wrong direction, swap a pair of wires at the starter panel’s main disconnect, then recheck motor direction of rotation.



Do not attempt to swap motor leads inside the SL-IV’s electrical enclosure. Swapping motor leads after the power disconnect switch will cause problems with motor phasing and the wye- delta start contactors.

3. After verifying motor rotation, replace cover.

3.3.3 Pump Operation

Perform the following steps before operating the pump.

1. Utilities Check:
Cutting Water – **ON**
Cooling Water – **ON**
Main Electrical Power – **ON**
Plant Air – **ON**
2. Install an orifice in the cutting head and close the nozzle control valve.
Insure all safety equipment is installed and working.

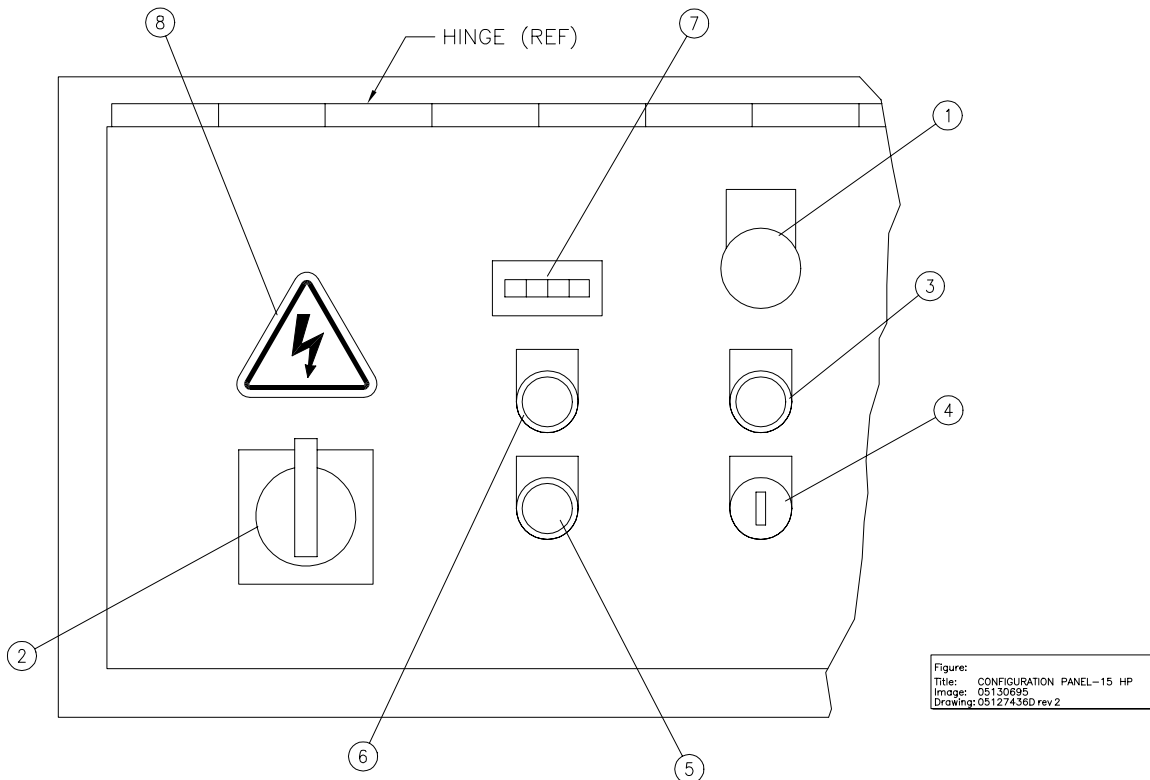

Item Description

- 1 Palmbutton – Emergency Stop
- 2 Handle – Electrical Disconnect
- 3 Pushbutton – (Control Power On—White Light)
- 4 Selector Switch-Local/Remote Control
- 5 Pushbutton – (Stop Pump/ Fault--Red Light)
- 6 Pushbutton – (Start Pump--Green Light)
- 7 Hourmeter
- 8 Decal—Shock Hazard

Pull out EMERGENCY STOP (E-STOP) palm button.

Press CONTROL POWER ON pushbutton to power up unit. The CONTROL POWER ON pushbutton should be lit.

Press START pushbutton to start pump. The intensifier assembly will stroke and stop when the HP lines are filled. The pump will maintain a constant HP water signal even though the nozzle is closed and no water is circulating. This is called standby or deadheaded condition.

- 3. Check for any leaks throughout the installation.
- 4. Remove front cover and locate the pump compensator adjustment screws. Remove cover nut on INBOARD adjustment screw, and loosen jam nut. Rotate 3 mm allen wrench clockwise to increase HP water signal, counterclockwise to reduce HP water signal. Maximum pressure is limited

to 4,600 bar (68,000 psi) by the tamper-resistant main hydraulic relief valve. (refer to procedure **3.3.4**)

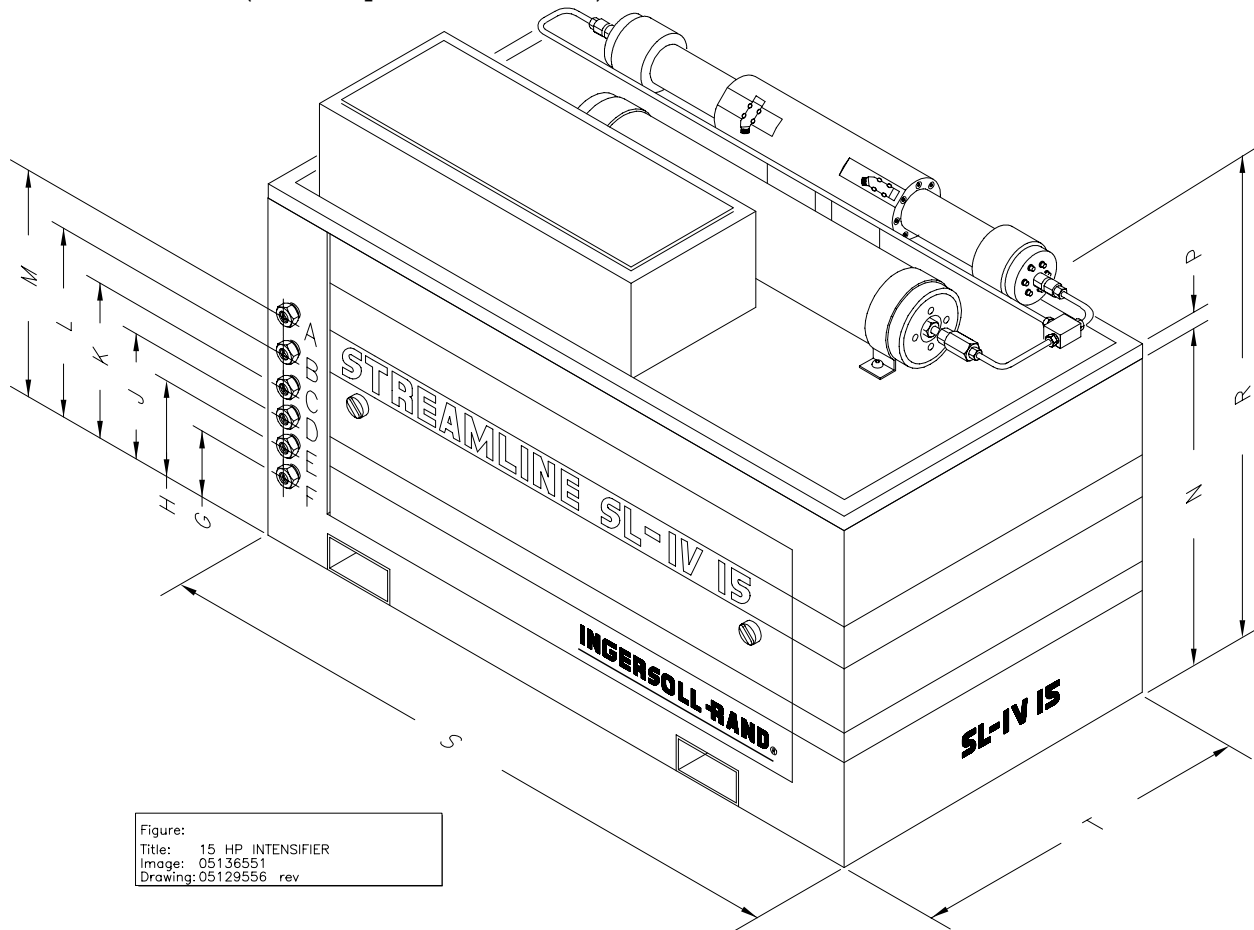

CAUTION

To assure proper oil viscosity and lubrication of the hydraulic system, always operate the unit at a hydraulic oil pressure of less than 70 bar (1,000 psi) until the oil temperature is at least 30°C (86°F).

5. Open nozzle control valve, the SL-IV pump will start stroking again. Turn inboard pressure compensator adjustment clockwise until reaching 1,034 bar (15,000 psi). Check for leaks.
6. Continue increasing pressure by 345 bar (5,000 psi) steps, checking for leaks every time, until reaching desired operating pressure.
7. To stop pump, press STOP button. It is recommended to bleed out the pressure through the nozzle.
8. Check emergency stop (E-STOP) and remote controls.
9. The pump is ready for normal operation.

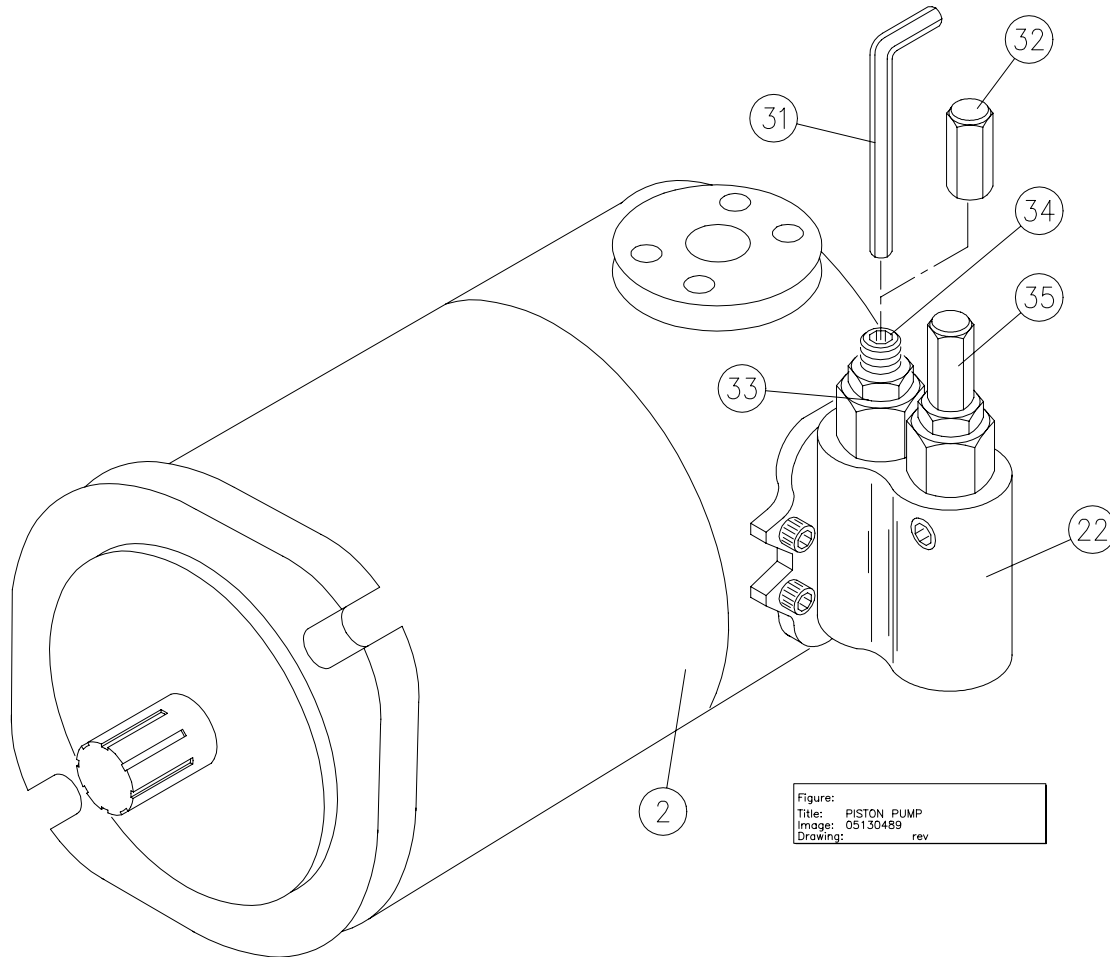

Figure:
Title: PISTON PUMP
Image: 05130489
Drawing: rev

2	Piston Pump	32	Cap Nut
22	Compensator	33	Jam Nut
31	Allen Wrench (3mm)	34	Adjustment Screw
		35	Outer Adjustment Screw

3.3.4 Hydraulic Pump Pressure Compensator Adjustment Procedure

- ❑ Locate hydraulic pump compensator adjustment screw
- ❑ Note that main adjustment screw is INBOARD, while outboard adjustment screw is used for pump internal case drain pressure.
- ❑ Use a 3mm Allen wrench to increase (clockwise) or decrease (counter-clockwise) pump compensator pressure.
- ❑ View a HP water pressure gage while adjusting the pump compensator.
- ❑ Increase pressure slowly, while the pump is supplying HP water to a nozzle orifice.
- ❑ Verify the static HP water setting by blocking flow to the HP water nozzle(s) either with the electrically- operated shutoff valve or by closing a suitable hand- operated shutoff valve.

- Note that the difference between HP water pressure with the nozzle(s) open and closed should be less than approximately 200 bar (2,900 psi). If the pressure difference exceeds 200 bar, then look for excessive line loss or possible blockage, such as a clogged HP water filter element.

3.4 Shutdown Procedure

NOTE

Relieve high pressure anytime the unit is stopped, by opening the nozzle control/cutting valve.

3.4.1 Normal Shutdown Procedure

Press the STOP button. The hydraulic power unit will shut down but control power (24vdc) will remain on.

3.4.2 Emergency Shutdown Procedure

An emergency stop is handled by pressing the EMERGENCY (E-STOP) palmbutton. This immediately shuts off all electrical power and vents the high pressure through the dump valve, out to drain.

3.4.3 Remote E-Stop Provisions

An emergency stop can be performed at a remote work station through wiring connections provided on the pump starter/control panel. This control option is useful when the operator is controlling the motion of a machine (robot, cutting box, X-Y motion table, etc.) without leaving the work station.

3.5 Fault Messages Overview

The pump will shutdown as a result of the following conditions.

3.5.1 High Oil Temperature Shutdown

1. ABNORMAL CONDITION red light will illuminate indicating that either: 1) the oil has overheated and the pump will shutdown due to high oil temperature, or 2) low oil level in the hydraulic reservoir (pump will shut down).
2. To correct the condition find the reason for the overheat.
3. After temperature returns to normal the illuminated red malfunction light will go out. The pump is ready to be restarted.
4. Restart the SL-IV Pump. Note that if the fed light is illuminated, the pump will not start.

3.5.2 Low Oil Level Shutdown

1. The unit will shut down immediately and the following occurs due to low oil level:
 - RUN green light will go OFF
 - ABNORMAL CONDITION red light will go ON

2. To correct the condition do the following:
 - Fill to proper level
 - Observe all safety procedures
 - Check for cause of low level, leaks, etc.
 - Make required repairs
3. After problem is corrected the following occurs:
 - ABNORMAL CONDITION red light should go OFF
4. Push START button and follow the start procedure to resume normal operation.

Section 4 MAINTENANCE**4 Maintenance**

This section provides an overview of “Scheduled Maintenance” and “Preventive Maintenance”. In addition, maintenance of the five systems is necessary and is described in their respective sections. Refer to the following sections for detailed information on the operator console and systems maintenance:

- Operator Console, Section 3
- Low Pressure Water, Section 6
- High Pressure Water, Section 7
- Electrical System, Section 8
- Hydraulic System, Section 9
- Recirculation System, Section 10

The following is an overview of the primary components and their location.

- **Hydraulic Pump** – including electric motor, and hydraulic valve manifold block. The pump is a variable displacement, axial piston and pressure compensated type.
- **Recirculation Pump** – including a fixed displacement gear – type pump, oil to water heat exchanger, hydraulic return line – type filter, and related hydraulic hoses and fittings. The gear pump mounts to the back of the variable piston pump, which has a through shaft.
- **Intensifier Assembly** – includes a high pressure (HP) attenuator, a hydraulic intensifier assembly, a HP dump valve and associated HP piping with fittings.

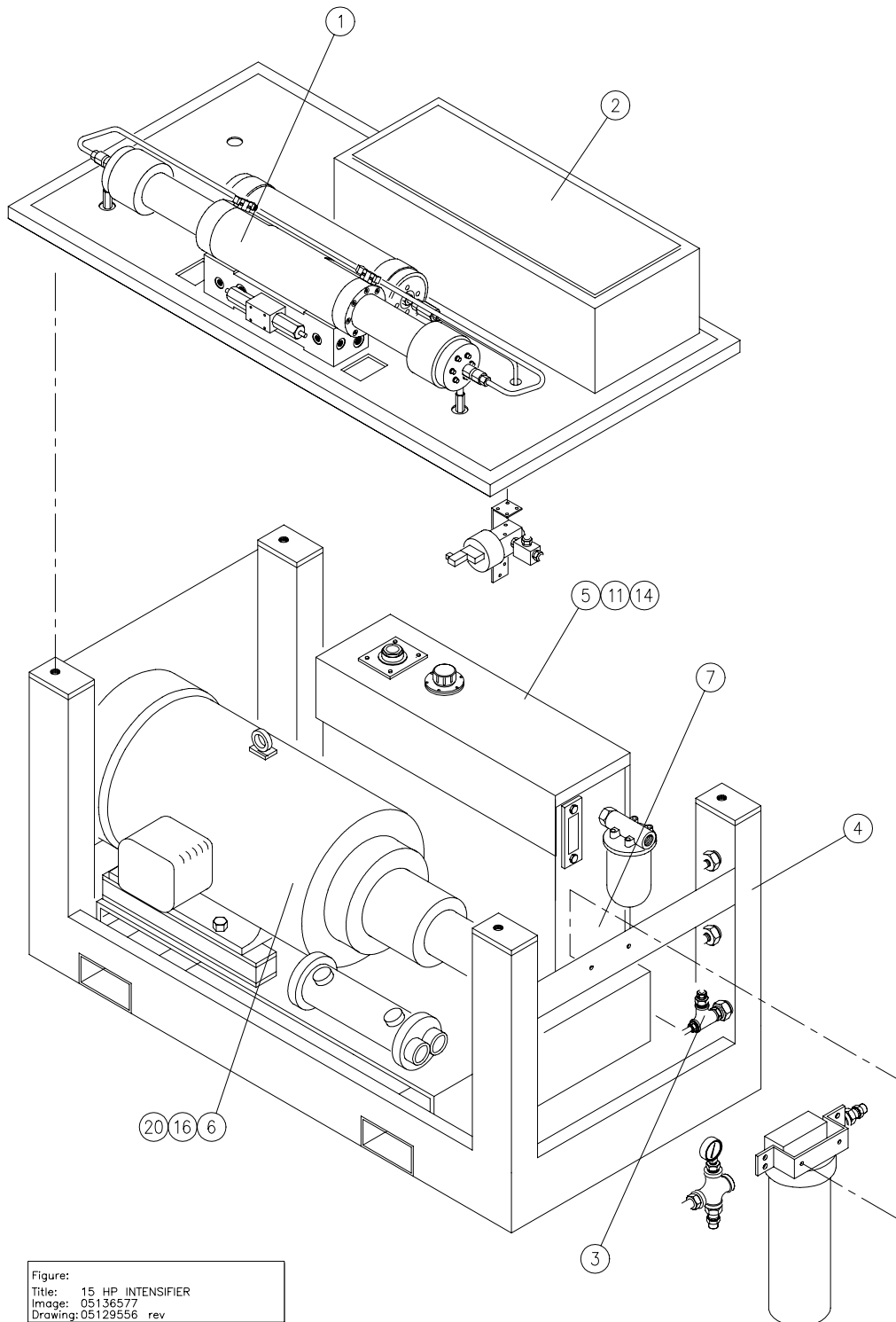

Figure:
Title: 15 HP INTENSIFIER
Image: 05136577
Drawing: 05129556 rev

Item Description

- (1) Hydraulic Pump
- (2) Recirculation Pump
- (3) Intensifier Assembly
- (4) Control Panel
- (5) HP Attenuator

4.1 Scheduled Maintenance

Check Description	Item to be Checked	Major Component	As Req'd	Per Shift	Weekly	Monthly	3-Month	6-Month	Yearly ¹
Fluid Level & Leak Checks	Oil Level	Hydraulic Oil Tank		X					R
	Oil Sample	Hydraulic System				F			
	Hydraulic Cartridge Seals	Hydraulic Cylinder	X	X					
	Plunger Seals	HP Cylinder	X	X					
	Sealing Head	HP Cylinder	X	X					
Pressure & Flow Checks	Water Supply Pressure	Low Pressure Filter Assembly	X	X					
	Intensifier Discharge Pressure	HP Piping	X						
	Hydraulic Pump Pressure	Hydraulic Pump		X					
Temperature Checks	Plunger Seal	HP Cylinder	X	X					
	HP Check Valve	Port Sealing Head	X	X					
	Cooling Water Inlet/Outlet	Oil/Water Heat Exchanger	X			F			
Lubrication & Filter Checks	Motor Bearings Lube	Hydraulic Power Unit	X					R	
	Hydraulic Filter	Hydraulic Oil Tank	X	X				R	
Vibrations-Rotating Equip.	Electric Motor					F			
	Hydraulic Pump					F			
System Cleaning & Inspections	Hydraulic Pump					F			
	HP Tubing, Valves, & Fittings					F			
	Hydraulic Manifold	Hydraulic Intensifier				F			
	Control Panel	Electrical Enclosure				F			
	Gage Calibration	Hydraulic Pump & HP Piping				F			
Control Lights			X						

Key:

- F:** Information
- X:** To be observed
- R:** To be replaced

¹Yearly or 3,000 hours, whichever comes first.

4.2 General Maintenance

Proper maintenance is important for reliable and consistent performance. Preventive maintenance reduces unscheduled downtime, and extends component life.



High pressure water will cut almost anything it contacts. Any leaks must be repaired immediately to prevent damage or serious personal injury.

Maintenance Guidelines

- Regular inspection of equipment is recommended.
- Keep equipment and surrounding areas clean.
- Check pressures, temperatures, and look for leaks.
- Make repairs immediately.
- A maintenance record should be kept.

Work Area

- Maintain a clean work area for repair and maintenance of the waterjet pump.
- Use a clean work bench in a dust and dirt free work area.
- Use lint-free material for wipe cloths.
- When blowing off parts with compressed air, use only clean, dry air. When flushing parts with a solvent, use only clean, filtered fluid.
- Always use original KMT Waterjet replacement parts, for consistent performance, reliability, safety, and to protect equipment warranty.

Safety Recommendations

- Carefully read the Safety Guidelines in Section 1, of this manual.
- Lock out all electrical power.
- Close all incoming supply valves and open all drain valves.
- Close the nozzle valves and manifold valves. When the power is shut off, the safety dump valve will open and bleed off high pressure water stored in the discharge piping.
- Provide suitable receptacles, pans, trays, etc. to catch and retain fluids to avoid a hazardous work area.
- DOUBLE CHECK to insure that all pressure is relieved from the system before proceeding.

Binding and Interference

When assembling close tolerance machine parts, use extreme care in aligning them for assembly. Do not force the parts together. If parts bind during assembly, separate them and try again until they are successfully mated.

NOTE

It should never be necessary to force an assembly together.

Plunger material is strong, but brittle. Avoid dropping, sharp blows, or heavy bending loads when working with these expensive parts.

Make sure all parts are clean, free of burrs, metal particles, dirt, dust, etc. Use High Purity Goop (I-R Part 10084440), when assembling any high pressure fitting.

After servicing any high pressure components, flush the high pressure water system by operating the waterjet pump for a short period with the nozzle valve open and no orifice in place. Next, shut down the waterjet pump, install an orifice, and slowly increase the discharge water pressure in stages. Check all high pressure connections for leaks.

Unusual requirements should be referred to the Technical Services group at KMT Waterjet.

To contact the KMT Waterjet Spare Parts Department:

USA: Parts Department
KMT Waterjet Systems
635 West 12th Street
Baxter Springs, KS 66713 USA
Phone: (620)856-2151
Fax: (620)856-5050

Europe: Spare Parts Manager
KMT Waterjet Systems GmbH
Wasserstrahl-Schneidetechnik
Auf der Laukert 11
D-61231 Bad Nauheim Germany
Phone: 49-(0)6032-997-115
Fax: 49-(0)6032-997-271

Section 5 TROUBLESHOOTING

SL-IV Pump Will Not Start

<i>Condition & Possible Causes</i>	<i>Corrective Action</i>
E-STOP Button Depressed	Pull out E-STOP button. Push CONTROL POWER ON button – white light on CONTROL POWER ON button should illuminate.
Power Disconnected	Check that main power is present. Check that main power disconnect is ON.
Control Power Interrupted	Check power supply circuit protection (tripped breaker). Check power supply (24vdc) input and output.
Motor Overload Relay Tripped	Find reason for overload. Reset overload relay.

Console Display and Lights Fail to Illuminate

E-STOP Button Depressed	Pull out E-STOP button. Push CONTROL POWER ON button - white light on CONTROL POWER ON button should illuminate.
Main Power Disconnected	Check main power.
Door Unlatched (locked out)	Check that the door disconnect switch is properly engaged.
Control Power Not Available	Check power supply circuit protection (tripped breaker). Check power supply (24vdc) input and output.

Pump Quit Running

Unsafe Operation Detected	Check fault indication on operator’s console. If red light illuminated, problem may be hot hydraulic oil or low hydraulic oil level. Correct out of limit condition and restart.
Electrical Power Interruption	Check power supply circuit protection (tripped breaker). Check power supply (24vdc) input and output. Check that main power is available.
Motor Overload Relay Tripped	Find reason for overload. Reset overload relay.

No Control Power (24vdc)

Circuit Breaker Tripped	Check input circuit breaker of power supply. Check output circuit breaker (24vdc) of power supply.
Power Supply Fault	Check power supply input and output voltages.

Red Flashing Light, Message On Operator’s Console

<i>Condition and Possible Causes</i>	<i>Corrective Action</i>
LEAK	Check for HP piping leaks. Check for HP seal leak. Check for HP check valve leak. Check for HP valve leak. Check for HP pump leak. Check for sufficient water supply.
OIL TEMP	Check orifices condition, and proper diameters. Check hydraulic oil tank temperature if above 62°C (144°F). Check cooling water flow and temperature to heat exchanger. Adjust water modulating valve.
OIL LEVEL	Check hydraulic oil level on the tank. Check for hydraulic oil leak, add oil to tank.

HP Water Signal Abnormal Fluctuation

Orifice Large/ Worn/ Damaged	Check that orifices do not exceed capacity of pump. Check that orifices are in good working order.
Check Piping Leaks	Check system components for leaks. Check HP Dump Valve for leaks, including through stem/seat.
Check Valve Leakage	Inspect pump discharge HP check valves. Inspect pump inlet low pressure (LP) check valves.
Check Seal Leakage Hydraulic Control Malfunction	Inspect plunger, sealing head seals. Check hydraulic valve operation. Verify proper shifting of 4-way reversing valve
Check Cutting Water Supply	Pressure of cutting water supply to intensifier should be at least 2 bar (30 psi).

Hot Surfaces On HP Cylinder Components

HP Discharge Check Leaking	Inspect check valve seat, poppet, spring, and guide condition.
LP Inlet Check Valve Leaking	Inspect check valve poppet, spring, seat, and sealing head.
Sealing Head or Plunger	Check plunger and sealing head seal leak and repair.
Damaged HP Cylinder	Check cylinder inside diameter for damage. Polish if required.

Oil or Water Leaks from HP Cylinder Weep Holes

<i>Condition and Possible Causes</i>	<i>Corrective Action</i>
Plunger Oil Seal Leak	Check hydraulic cylinder O-ring leakage. Check proximity switch area for oil leakage. Remove, inspect, replace or clean hydraulic seal (cartridge).
Water Leak at HP Plunger Seal	Replace seal assembly. Check plunger and follower if leak exceeds about 1 drop in 10 strokes. Check for scratches, circumferential grooves, or material build up on inside diameter of HP cylinder. Polish if required.
Water Leak at Sealing Head Seal	Check seal assembly. Check for scratches on inside diameter of HP cylinder. Polish if required. Check for scratches in area of sealing head seal. Polish if required.

Hot Hydraulic Oil

Restricted or No Cooling Flow	Check cooling water flow to and from heat exchanger. Check setting of water modulating valve. Check water pressure differential across heat exchanger, 2.75 bar (40 psi) minimum required for flow through the exchanger. Check operation of water modulating valve.
Water Modulating Valve Set High	Check and adjust setting of water modulating valve.
Heat Exchanger Clogged	Flush heat exchanger, improve quality of cooling water.

Low Cutting Water Pressure

Low Hydraulic Pressure Setting	Check hydraulic pump pressure setting. Verify that hydraulic pump compensator adjustment operates normally (clockwise adjustment increases hydraulic pressure setting)
Restricted or No Cutting Water Supply Water Filter Clogged	Check cutting water supply flow and pressure Visually check appearance of filter element. Check water pressure at filter gage. Replace filter element, note any improvement in pressure gage reading under equivalent operating conditons.
Air Trapped	Bleed air from cutting water plumbing.

HP Check Valves Leak

If there are no visible HP water leaks, but there are higher temperatures on HP cylinder or sealing head, this is an indication of a HP or LP check valve leak. Use corrective action listed at right:

1. Disconnect the proximity switch cable of either HP cylinder.
2. With the cutting nozzle valve open, start pump at low pressure; the piston will move and stop at the opposite HP cylinder.
3. Stop pump, assure all pressure is bled; plug HP cylinder.
4. Start pump, adjust hydraulic pump to high pressure.
5. Assure there are no external water leaks.
6. Reconnect the proximity switch cable. The piston will reverse:
 - If the plunger moves (the problem side proximity switch light will turn ON), it indicates an inlet check valve problem.
 - If the plunger does not move, it indicates a HP discharge check valve problem.

Normal Temperature, but Check Valve Problem

Since the HP check valves are interconnected, to determine which of the two inlet check valves or two discharge check valves is causing the problem, follow these procedures.

Check inlet HP check valve

1. Follow the procedure outlined in "HP Check Valves Leak".
2. A bad inlet check valve will be indicated by a piston moving after the proximity switch cables are reconnected.

Check discharge HP check valve after completing inlet check.

1. Re-install all HP plumbing and proximity switch cables
 2. Start pump, then close nozzle valve.
 3. Stop pump and watch high pressure gage.
 4. If the pressure drops, one of the two discharge check valves is leaking.
 5. Determine which valve is leaking by inspection. Look for erosion or uneven wear on the poppet or seat.
-

Section 6 LOW PRESSURE WATER SYSTEM

6 Features

The SL-IV Waterjet Pump is equipped with two low pressure circuits:

- Cutting water supply for HP intensifier assembly.
- Cooling water supply for the oil-to-water heat exchanger.

The low pressure water system supplies the pump with the following:

- Water of sufficient cleanliness and pressure to the inlets of the two (2) HP cylinders.
- Cooling water of sufficient flow rate and low temperature to the oil-to-water heat exchanger.

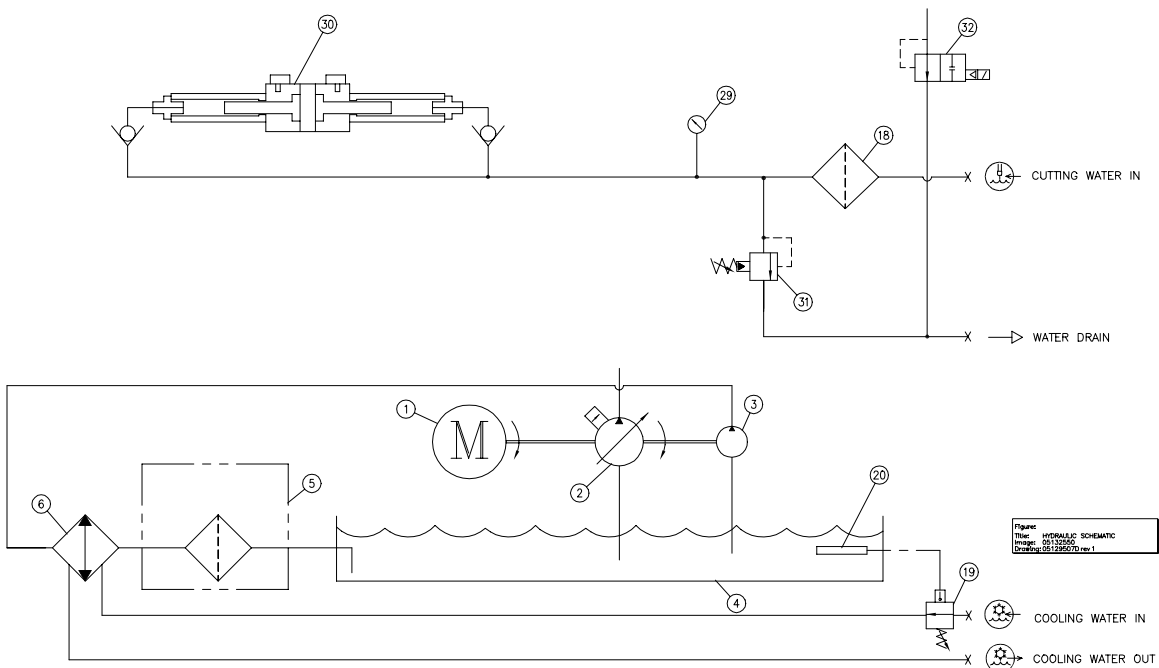

- | | |
|--------------------------------|-----------------------------------|
| 1 Motor, Electric | 19 Valve, Water Modulating |
| 2 Pump, Main Hyd | 20 Thermal Bulb, Water Modulating |
| 3 Pump, Recirculating Hyd | 29 Pressure Gage, Cutting Water |
| 4 Reservoir, Hyd | 30 Intensifier Assy |
| 5 Filter Assy, Hyd | 31 Valve, LP Water Relief |
| 6 Heat Exchanger, Oil-to-Water | 32 Valve, HP Water Dump |
| 18 Filter, LP Water | |

6.1 Oil Cooling Water Supply

The oil cooling water supply circuit includes the water modulating valve.

The maximum flow rate of the cooling water is specified in Section 11 “**Specifications**” under “Hydraulic Oil Cooling.” A minimum inlet pressure of 2.8 bar (40 psig) and 21 deg C (70° Fahrenheit) maximum

inlet temperature is required to maintain oil temperature under extreme operating conditions.

Cooling water flow rate is regulated by the water modulating valve (19). A thermal bulb (20) mounted in the hydraulic reservoir varies cooling water flow rate relative to hydraulic oil temperature. Higher oil temperatures tend to cause the water modulating valve to open, allowing more cooling water to flow to the heat exchanger (6). See Section 10 **“Recirculation”** for operating instructions concerning the water modulating valve.

6.2 Cutting Water Supply

The cutting water supply includes the following:

- Low pressure water filter
- Quick disconnect couplings at the intensifier inlet ports

The low pressure water fittings are stainless steel or brass with rubber hoses connecting the low pressure water components.

The low pressure water circuit is equipped with a pressure gage to indicate inlet water conditions to the intensifier.

Quick disconnects are provided at each of the HP cylinder inlet check valve/sealing head ports for ease of maintenance, preventing low pressure water from spraying out when this connection is broken.

6.2.1 Normal Operating Condition

During normal operation, the low pressure water system maintains the following conditions:

- Pressure gage reads 2 bar (30 psig) or greater while intensifier is pumping at maximum flow rate.
- Components feel cool to touch, indicating no HP water leaks into cutting water supply.

6.2.2 Operation

The cutting water enters the SL-IV Pump through a bulkhead fitting.

NOTE

Inlet pressure is affected by filter condition, as well as local water supply conditions.

The water flows through the low pressure water supply filter (18), then through quick disconnect fittings (not shown) to each of the two inlet check valves on the intensifier assembly (30). Note that a pressure gage (29) provides indication of cutting water supply conditions. Gage reading should exceed 2 bar (30 psig) to assure proper intensifier operation. A relief valve (31) in prevents excessive pressure in the cutting water supply caused by a leaking HP inlet check valve. Possible check valve(s) located away from the SL-IV Pump would otherwise trap water being leaked from HP check valves.

The water filter assembly includes a small bleed valve that is useful in performing maintenance on the filter. Prior to removing the filter bowl the bleed valve provides a convenient means of releasing any pressure trapped inside the filter. After a filter element has been replaced, this bleed valve provides a means of purging air from the water that could be detrimental to HP seal performance.

6.2.4 Low Pressure System Protection

6.3 Maintenance Overview

In order to maintain necessary fluid pressure for the intensifier and to keep the water clean for proper operation periodic maintenance on the water filter is necessary. The guidelines for servicing these parts are described below.

6.3.1 Water Filter Service

Replace filter element when cutting water pressure gage reads less than 2 bar (30 psig):

Components:	Bleed Valve Element Head Housing
Recommended Tools:	Supplied filter thread/unthread tool (to turn housing) Container (to capture some water spill) Rags
Parts:	Elements for water: 10 micron (quantity 2) Polymer mixture: 40 micron (quantity 2)

Water Filter Element Replacement Procedure

1. Turn off cutting water supply
2. Press bleed valve to relieve trapped pressure
3. Unscrew housing from head. Remove element.
4. Install new element in housing. Screw housing into head.
5. Open cutting water supply.
6. Press bleed valve to remove trapped air.
7. Start waterjet pump. Verify satisfactory pressure reading.

Section 7. HIGH PRESSURE WATER SYSTEM – SL-IV 15hp

7 High Pressure (HP) Water

The high pressure (HP) water system takes the relatively low pressure water inlet to up to 3,800 bar (55,000 psi) supplying orifice diameters appropriate to the waterjet pump’s operating power (See Specifications, Section 11).

7.1 Components

The high-pressure water components include the hydraulic intensifier, HP attenuator, HP dump valve and HP piping. Maintenance on the intensifier is discussed in detail in this section. In addition to HP components and assemblies, the hydraulic cylinder aspects of the intensifier are discussed in this section.

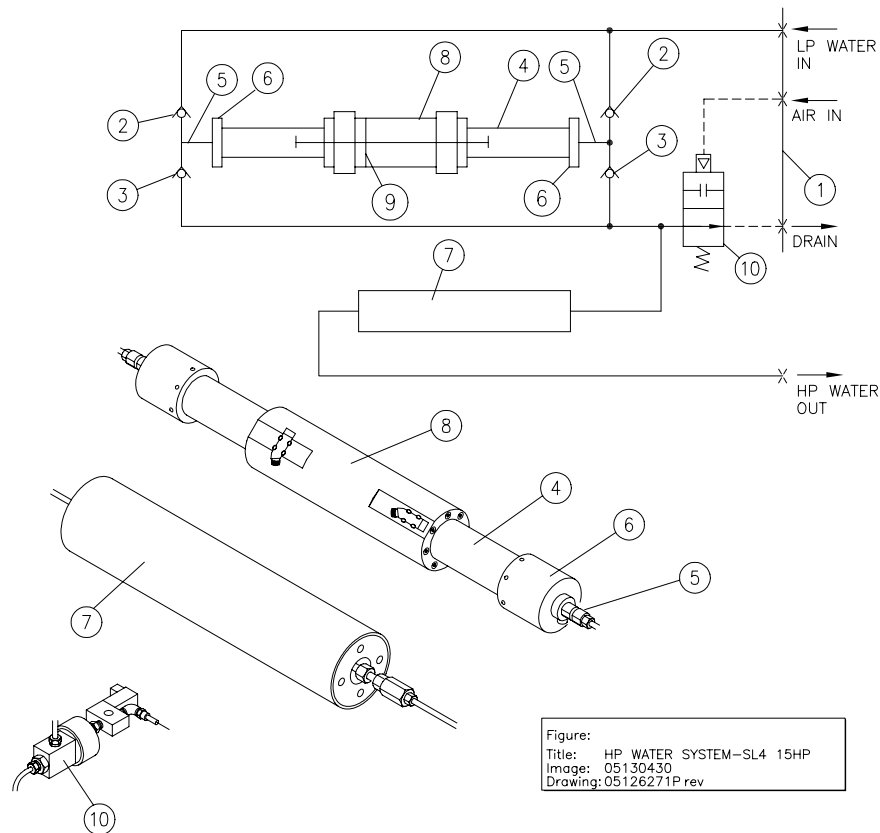

Item Description

- | | | |
|-----------------------|------------------------|---------------------------|
| (1) Bulkhead Fittings | (2) Inlet Check Valve | (3) Discharge Check Valve |
| (4) HP Cylinder | (5) Sealing Head | (6) Sealing Head Nut |
| (7) HP Attenuator | (8) Hydraulic Cylinder | (9) Hydraulic Piston |
| (10) HP Dump Valve | | |

7.2 Intensifier Disassembly and Reassembly

Detailed instructions are provided on disassembly and reassembly of the hydraulic intensifier, including HP seal maintenance. A discussion of detailed inspection and repair for individual HP subassemblies is also provided. The HP attenuator is discussed but no disassembly procedures are included since attenuators are not serviceable by the customer.

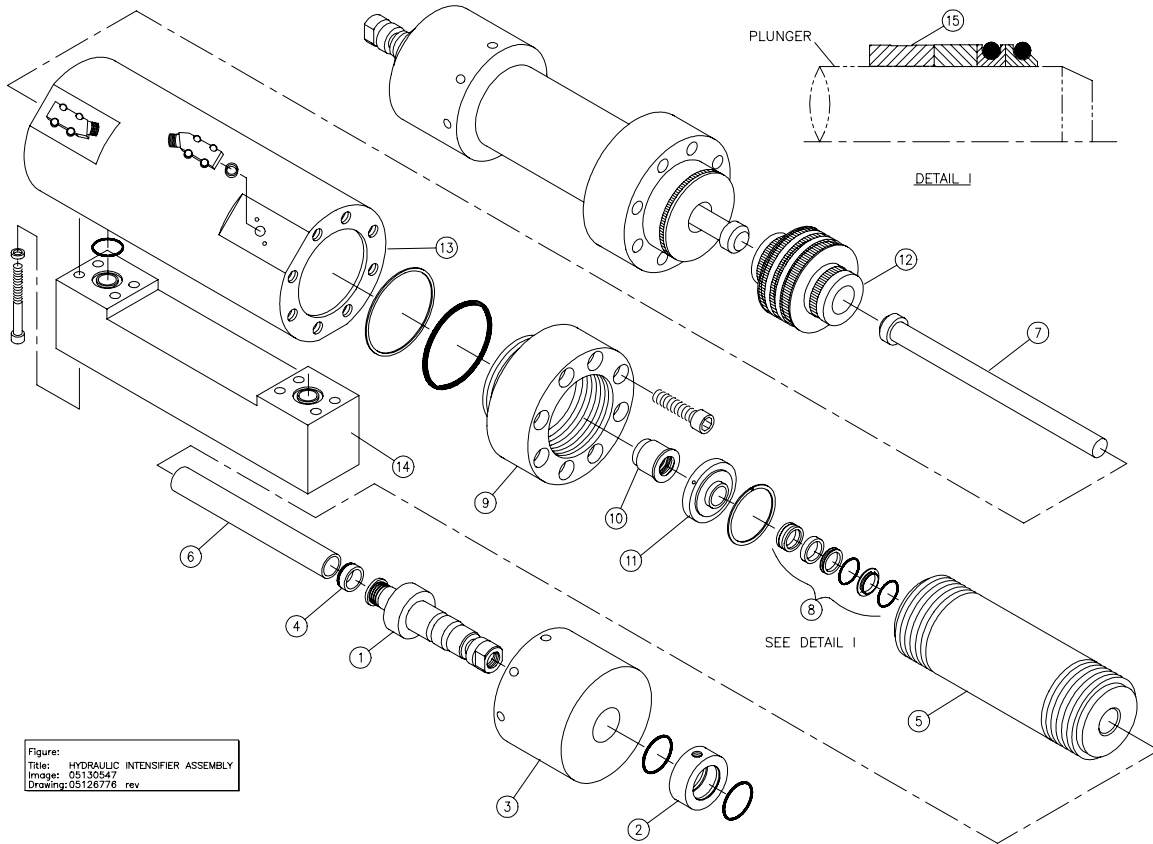

Figure:
Title: HYDRAULIC INTENSIFIER ASSEMBLY
Image: 05130547
Drawing: 05126776 rev

Item Description

- | | | |
|-------------------------------|-------------------|-----------------------|
| (1) Sealing Head | (2) Collar | (3) Sealing Head Nut |
| (4) Head Seal | (5) Cylinder Body | (6) Cylinder Liner |
| (7) Plunger | (8) Plunger Seal | (9) Cylinder Head |
| (10) Hydraulic Cartridge Seal | (11) Flange | (12) Piston |
| (13) Cylinder | (14) Manifold | (15) Packing Follower |

**7.2.1 HP & LP Water Piping
Disconnect from/Reconnect to Waterjet Pump****WARNING**

Before performing maintenance on the waterjet pump observe electrical LOCK OUT/TAG OUT procedures.

1. With 13/16" open wrench loosen and remove HP Piping attached to discharge HP check valve. Move tubing to clear work area.
2. For servicing discharge HP check valve on the intensifier assembly, refer to section 7.3.1."Discharge HP Check Valve".
3. The sealing head can be removed with the discharge HP check valve attached. Remove the low pressure water quick disconnect and gently pry the collar off the sealing head.
4. With the HP piping and the low pressure cutting water plumbing disconnected, the following operations can be performed:
 - Sealing head can be removed from the HP cylinder
 - HP cylinder can be removed from hydraulic cylinder head
 - HP seals (sealing head and plunger) can be serviced

After the pump has been reassembled, then the HP water piping, quick disconnect and collar are reinstalled as follows:

5. Slide inlet water collar over sealing head until it rests against the head nut. Connect LP inlet water quick disconnect to collar.
6. Install the HP water piping. Tighten HP connections using a 13/16" crowfoot wrench. Use a 30mm (1-3/16") wrench for back-up on the sealing head, and a 1" wrench for back-up on the elbow. Turn on cutting water supply and check for low pressure leaks.

**CAUTION**

Check that all proximity switches are properly installed and secured prior to starting the motor. Failure to tighten proximity switch hold down screws (2 each per proximity switch) will result in hydraulic oil spraying in general directions.

7. Start the waterjet pump. Operate at low pressure (without a cutting orifice) to flush the HP passages, then operate at high pressure with orifice installed to check for leaks.

7.2.2 HP Sealing Head--Remove from/Install in Waterjet Pump

1. Remove low pressure and HP piping from sealing head using procedure in Section 7.2.1.
2. With pin spanner wrench located on head nut to turn counterclockwise, and cylinder wrench installed on cylinder to hold in opposite direction of rotation; break the head nut loose. Tapping the pin spanner wrench with plastic hammer may be required.
3. Unscrew head nut until it is flush with the water inlet groove on the sealing head. With a screwdriver in the groove, and supported by the head nut, gently pry the sealing head out as far as possible; continue repeating the process until the sealing head is loose from the cylinder. Continue unscrewing the head nut and remove nut from HP cylinder.

NOTE

Parts are heavy; avoid dropping.

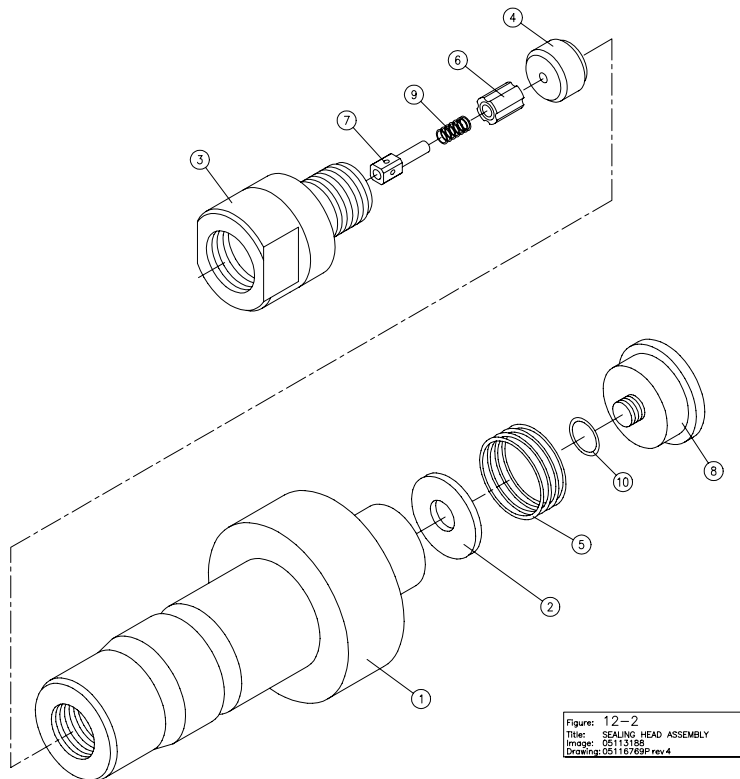

- | | | |
|------------------|---------------------|----------------------|
| (1) Sealing Head | (2) Inlet Poppet | (3) Gland Nut |
| (4) Ball Seat | (5) Inlet Spring | (6) Poppet |
| (7) Guide Pin | (8) Poppet Retainer | (9) Discharge Spring |
| (10) O-Ring | | |

4. Remove the sealing head. Using the seal removal tool, remove the HP seal components remaining in the HP cylinder outboard end. Remove the cylinder bore liner.
5. The HP cylinder can now be removed for further tear down, or the sealing head and HP seal can be serviced. *Note that a fully assembled spare sealing head greatly reduces pump down-time.*
6. Prior to installing a new sealing head HP seal, the following tasks should be accomplished, as necessary:
 - Inspect and service inlet check valve
 - Inspect and polish sealing head seal surfaces
 - Inspect and polish HP cylinder outboard bore surface
7. Wipe the bore liner clean, then install it into the HP cylinder.
8. Lightly grease the head seal components with food grade grease before installing. Slide the seal assembly onto the boss of the sealing head. The tan, hard plastic back-up ring must shoulder against the seal shoulder. The ring is chamfered and must be installed against the chamfered shoulder of the sealing head. The HP seal must be installed with the O-ring facing the inlet HP check valve.
9. Lightly lubricate the inside of the HP cylinder outboard end with food grade grease. Ensure threads are clean and undamaged. Lubricate cylinder threads with High Purity Goop.
10. Fit the sealing head assembly and head nut together. While holding the sealing head assembly securely against the head nut, thread nut onto the HP cylinder. Avoid knocking the end of the seal head against the HP cylinder to prevent damage to the inlet check valve and to seals or sealing surfaces.
11. As the head nut threads onto the HP cylinder and the sealing head begins to resist turning, tap the sealing head outboard end with a plastic hammer until the sealing head seats against the end of the HP cylinder. Alternatively, the sealing head can be pushed gradually into place by threading the sealing head retainer nut.

NOTE

It is important to avoid rotating the sealing head relative to the HP cylinder, as this may cause premature HP seal leaks.

12. The head nut can be threaded by hand onto the HP cylinder. Turn the head nut until it bottoms out. Then tighten the head nut with the spanner wrench, finishing with a single, light tap on the wrench handle. Any torque greater than this could cause problems with loosening the head nut during subsequent disassembly.

7.2.3 HP Cylinder**Remove from/Install in Waterjet Pump**

The HP cylinder can be unthreaded from the cylinder head either with or without its head nut and sealing head assembled to it. We recommend the following procedure since the combined parts make up a rather heavy assembly that is difficult to handle.

Note that if replacing HP seals in one cylinder without replacing plunger, then plunger can be stopped in fully –retracted position by disconnecting opposite-end proximity switch cable while pump is running, then proceeding with HP cylinder disassembly.

1. Remove sealing head from HP cylinder by following procedures outlined in Section 7.2.2.
2. Unthread the HP cylinder from its hydraulic cylinder head using the special cylinder wrench. Support the weight of the cylinder until it completely clears the plunger (item (31), Figure 12-1 **Parts Lists**). The cylinder is heavy and may damage the plunger or cause injury if it is not supported.
3. With the HP cylinder removed the plunger HP seal can be serviced and the complete cylinder can be inspected and polished as described in Section 7.3.4. Remove the plunger HP seal and seal follower from the HP cylinder using the special aluminum seal removal tool. Be careful not to scratch the bore of the HP cylinder.
4. Remove cartridge retainer flange from hydraulic cylinder head by first removing retaining ring using a flat blade screwdriver. Wipe and clean surfaces, weep holes, and grooves in cartridge retainer flange. Check retainer flange for cracks.
5. Prior to installing a new plunger HP seal, the following tasks should be accomplished, as necessary:
 - Inspect plunger’s exposed surface for scratches, surface discoloration, or unusual contact markings. Remove and replace plunger
 - Inspect and polish HP cylinder bore surface (refer to Section 7.3.4 “HP Cylinder”).
6. Reinstall the cartridge retainer flange with its retaining (snap) ring. Before assembly, lightly lubricate the packing follower and the seal assembly with food grade grease. Note that the inside diameter groove of the packing follower should be greased. Slide plunger seal packing follower over plunger. Install plunger HP seal assembly over plunger in the following order:
 - Solid plastic backup ring against follower
 - U-shaped seal and O-ring against backup ring

- J-shaped seal body and O-ring against U-shaped seal body. The open side of the J-seal should face outboard (toward the sealing head).
7. Inspect the HP cylinder threads and apply High Purity Goop to the threads and shoulder guides, then screw the HP cylinder into the hydraulic cylinder head. Note that shoulder guides are close-fitting smooth diameters located at either end of cylinder threads. Be sure to support the weight of the HP cylinder. As the HP plunger seal goes into the cylinder, the cylinder will become difficult to rotate. Use the special cylinder wrench to assist, as necessary.
 8. Tighten the HP cylinder hand tight with the cylinder wrench, then tap the cylinder wrench with the hand's palm to tighten.
 9. Install bore liner into HP cylinder. The sealing head can now be installed onto the HP cylinder (Section 7.2.2).

7.2.4 Hydraulic Seal Cartridge & Plunger -- Remove/Install

With the HP cylinder removed from the hydraulic cylinder head (Section 7.2.3), the following items become accessible:

- Cartridge retainer flange
 - Hydraulic seal cartridge
 - Plunger
 - Hydraulic cylinder head
 - Hydraulic piston and cylinder
1. Remove the proximity switch on the intensifier side nearest HP cylinder to be serviced. This procedure will allow hydraulic oil to drain to tank and will minimize oil spillage. Draining takes about 5 minutes.
 2. To remove the hydraulic seal cartridge, use a screwdriver to remove the internal retaining (snap) ring that holds in the cartridge retainer flange. Remove cartridge retainer flange.

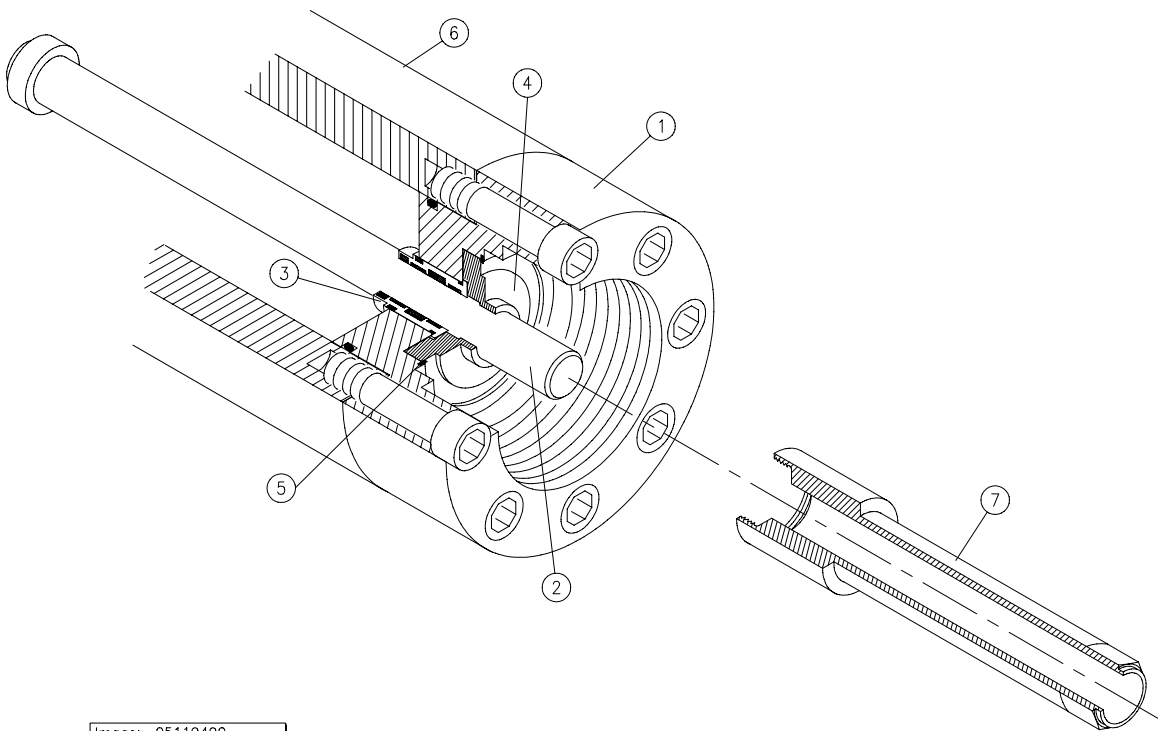

Image: 05119490
Drawing: 05113030 rev

Item Description

- | | |
|---------------------------------------|-----------------------------|
| (1) Cylinder Head | (2) Plunger |
| (3) Hydraulic Cartridge, Plunger Seal | (4) Bushing Retainer Flange |
| (5) Retaining Ring | (6) Hydraulic Cylinder |
| (7) Plunger Removal Tool | |

3. Using cartridge/plunger removal tool threaded to the seal cartridge, pull the cartridge outward over the plunger. Seals in the hydraulic cartridge can be removed and replaced, or the entire cartridge can be replaced. It is recommended that at least one spare cartridge be kept on hand, ready to install. See Section 7.3.6 for servicing hydraulic seal cartridge.
4. With the cartridge removed, the plunger can be removed with the cylinder head in place. Slide the cartridge/plunger removal tool over the plunger, with the hex-shaped smaller end toward the plunger button. Note orientation of plunger button retainer pins (6 each), then align hex flats of tool with pins. Force tool by hand under pins, then rotate tool slightly to cause pins to retract enough to release plunger. Plunger can now be extracted from hydraulic piston. See Section 7.3.5 for servicing the plunger.
5. To install new plunger, slip cartridge/plunger removal tool over plunger, hex end toward plunger button, to help center plunger in cylinder head. Position plunger in mating pocket of piston, then force into place by hand. Using a flashlight, verify that all 6 pins are equally extended to grip plunger button.
6. Lubricate exposed surfaces of seals in hydraulic seal cartridge with food grade grease and slide cartridge over plunger into cylinder head cavity.
7. Thoroughly clean cartridge retainer flange, including cross-drilled weep holes. Install flange and internal retaining ring, making sure that the retaining ring seats fully inside its groove. Avoid orienting the snap ring gap in the cylinder head weep groove.
8. HP cylinder and sealing head can now be assembled to the waterjet pump per Sections 7.2.3 and 7.2.2.

7.2.5 Hydraulic Cylinder Head and Hydraulic Piston**Disassembly**

1. Remove sealing head and HP cylinder using procedures in Sections 7.2.2 and 7.2.3.
2. Remove proximity switch (19) at cylinder end to be serviced. If both cylinder heads and/or the hydraulic piston (21) are to be removed, both proximity switches must be removed.
3. Remove hydraulic seal cartridge (8). Seal cartridge (8) removal is recommended to avoid sliding cylinder head (4) over plunger (2). The plunger need not be removed at this stage. Note that potential plunger damage can be avoided if plunger is removed prior to unbolting cylinder head.
4. Loosen and remove 8 each socket head cap screws (18) retaining cylinder head (4) to hydraulic cylinder (15). The cylinder head and its O-ring (16) can be removed. The proximity switch mounting flats provide a small lip for loosening the cylinder head.
5. To remove the hydraulic piston (21) from the hydraulic cylinder (15), remove both cylinder heads. The piston must be driven from the cylinder bore due to the seal squeeze and friction. Use a plastic head hammer to avoid striking the assembly with a metal object. See Section 7.3.7 for servicing the hydraulic piston.
6. Reassemble the hydraulic cylinder by reversing the above steps.

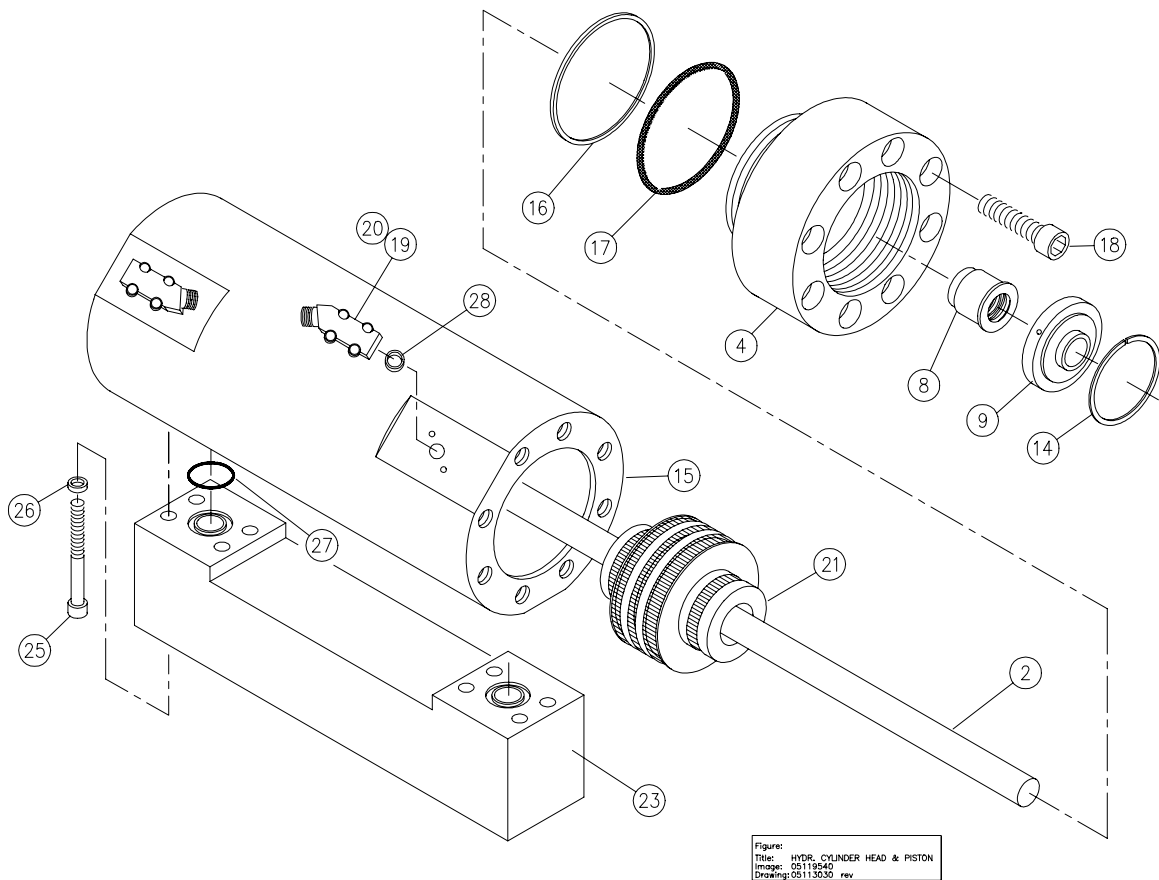

Item Description

- | | |
|--------------------------------------|-----------------------------|
| (2) Plunger | (4) Cylinder Head |
| (8) Hyd Cartridge, Plunger Seal Assy | (9) Bushing Retainer Flange |
| (14) Retaining Ring | (15) Hydraulic Cylinder |
| (16) O-ring | (17) Backup Ring |
| (18) Cap Screw | (19) Proximity Switch |
| (20) Cap Screw | (21) Hyd Piston Assy |
| (23) Manifold | (25) Cap Screw |
| (26) Lockwasher | (27) O-ring |
| (28) Spacer | |

7.3 Intensifier Subassemblies Inspection and Repair

The inspection and repair of the following subassemblies will be discussed:

- Discharge HP Check Valve, Section 7.3.1
- Inlet Check Valve, Section 7.3.2
- Sealing Head, Section 7.3.3
- HP Cylinder, Section 7.3.4
- Plunger, Section 7.3.5
- Hydraulic Seal Cartridge, Section 7.3.6
- Hydraulic Piston, Section 7.3.7
- Hydraulic Cylinder, Section 7.3.8

7.3.1 Discharge HP Check Valve

The HP discharge check valve can be serviced with the sealing head either installed in or removed from its intensifier HP cylinder.

1. Remove the gland nut from the sealing head using two 30mm (1-3/16") wrenches.
2. When the gland nut is removed, the spring guide and spring will normally stay in the gland nut. The poppet is removed by carefully dislodging it with a screwdriver. The valve seat is removed with a magnet. Inspect the seat for damage or cracking. A cracked seat should be replaced. The seat is symmetrical, and can be installed with either face toward the poppet. Note that a slight burr at the hole edge identifies the used side of the poppet seat. When reinstalling the seat, apply a thin film of High Purity Goop to both faces. Install the seat into the sealing head with the best surface facing the check poppet.

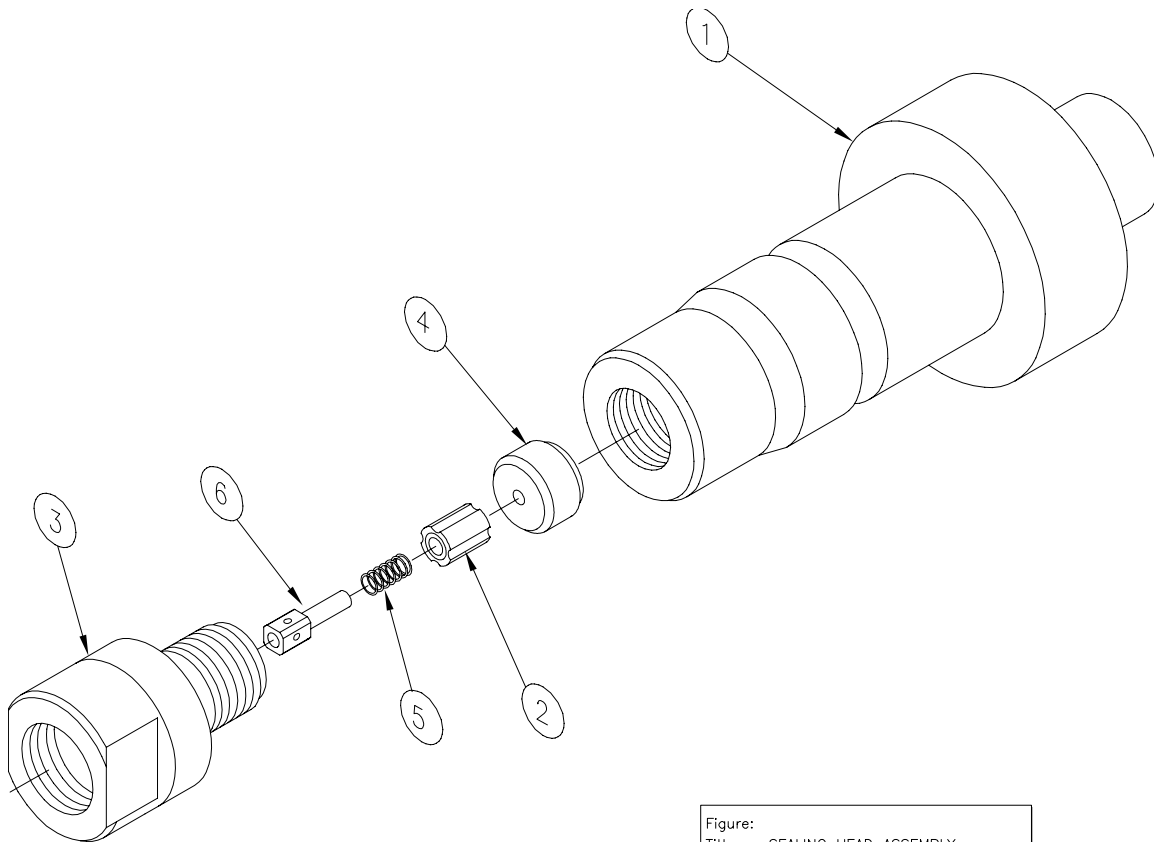

Figure:
Title: SEALING HEAD ASSEMBLY
Image: 05114798
Drawing: 05116769P rev 4

Item Description

- | | | |
|------------------|------------|---------------|
| (1) Sealing Head | (2) Poppet | (3) Gland Nut |
| (4) Poppet Seat | (5) Spring | (6) Guide Pin |

3. Inspect the poppet, spring, and guide for wear. Replace the spring and guide if worn.
4. Apply a thin film of High Purity Goop to the sealing face of the gland nut. Install the guide, spring, and poppet into the gland nut. Apply a coating of food grade grease to the check poppet to hold it in place when installing gland nut in sealing head.
5. Apply High Purity Goop to the gland nut threads. Install the gland nut into the sealing head. The gland nut should be hand tightened until there is a gap of 5mm (0.20") between the gland nut and sealing head. No threads should show. If the gap exceeds 5mm (0.20"), then the poppet has slipped out of place, and the parts must be removed, inspected and reassembled.
6. Using a 30mm (1-3/16") crowfoot/torque wrench combination, torque the gland nut to 88 Nm (65 ft-lbs.).
7. Reconnect high pressure and low pressure piping, collar and quick disconnects per Section 7.2.1. Operate waterjet pump to verify HP fittings do not leak, and that the HP water signal is normal (indicative of normal check valve operation).

7.3.2 Inlet Check Valve

1. Use a ½” flat bladed screwdriver to unscrew the poppet retainer from the sealing head. The inlet check valve is disassembled.
2. Inspect and refinish the sealing head face seal surface per instructions in Section 7.3.3.
3. Inspect both surfaces of the flat washer shaped poppet. If one surface is marred, and the opposite surface is not, the poppet may be reversed with the best surface facing the sealing head. If both sides are worn, replace poppet.
4. Insure the poppet retainer threads, and the mating threads in the port sealing head are clean and dry. Install small O-ring over threads.
5. Assemble the inlet poppet, spring, and retainer to the sealing head using a ½” flat blade screwdriver.
6. Inspect the assembled unit to insure the following:
 - The poppet moves freely.
 - The spring is fully guided on the poppet retainer.
 - The spring end is 90° from the retainer’s screwdriver slot.
 - The poppet retainer is shouldered against the sealing head.
 - O-ring is sandwiched between poppet and body.

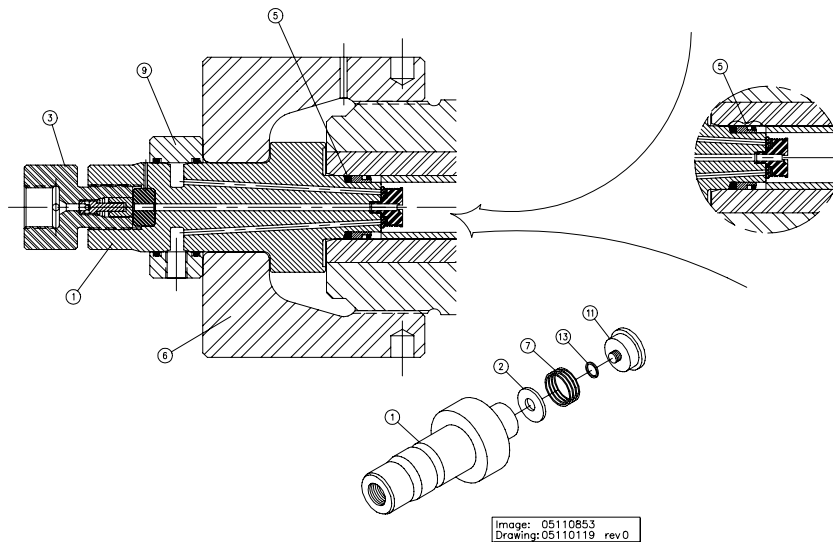

Item Description

- | | | |
|------------------|---------------|--------------------|
| (1) Sealing Head | (2) Poppet | (3) Gland Nut |
| (5) Head Seal | (6) Head Nut | (7) Suction Spring |
| (9) Collar | (11) Retainer | (13) O-Ring |

7.3.3 Sealing Head

The sealing head should be inspected for scratches and wear on two surfaces:

- HP seal contact surface
- Inlet HP check valve poppet contact surface

In addition, the sealing head inlet water groove should be examined for cracking.

1. Inspect the inlet poppet sealing surface of the sealing head for pits, scratches, or jetting erosion. Refinishing the seal head inlet poppet face is mandatory when rebuilding the sealing head. Using a piece of plate glass (not window glass) on a sturdy table, place a piece of 400 grit wet/dry sandpaper atop the plate of glass which provides the absolutely flat surface necessary for the polishing process. Using even, deliberate strokes, polish the sealing head until smooth. Rotate the head about 10-15 degrees every stroke. Be careful not to tilt or tip the head while polishing it as to not scrape the part.
2. When the sealing head is flat and smooth, perform a final polish with 600 grit wet/dry sandpaper. A mirror finish is required. KMT Waterjet offers a refinishing service.

7.3.4 HP Cylinder

1. At a workbench, use the seal removal tool to prevent scratching the cylinder bore sealing surface. Use a pulling action to remove the sealing head HP seal.
2. Remove the bore liner. Use a plastic-faced hammer and the seal removal tool to drive out the plunger HP seal and follower. Be careful not to scratch the bore of the cylinder or damage the cylinder threads.
3. Clean sealing areas of HP cylinder inside diameter and inspect cylinder for rings, scratches, pits, residue build-up and other potential leak paths. Seal material or residue can build up forming a ring, and running a fingernail across it, will cause it to appear as a surface flaw. It is usually necessary to clean the area before performing an inspection.
4. Use 600 grit wet/dry sandpaper to polish HP cylinder inside diameter where the seal will locate. Polish only in a circumferential motion. Do not polish or drag the sandpaper along the length of the cylinder. Hold the sandpaper on the end of your finger, and move in a cylindrical wiping motion in the bore of the HP cylinder. Wipe residue from cylinder inside diameter and re-inspect for surface defects.

NOTE

The HP cylinder ends often show a “step” between inner and outer sleeves where the inner sleeve extends beyond the outer by a small amount. This is normal and does not indicate a flaw in the cylinder.

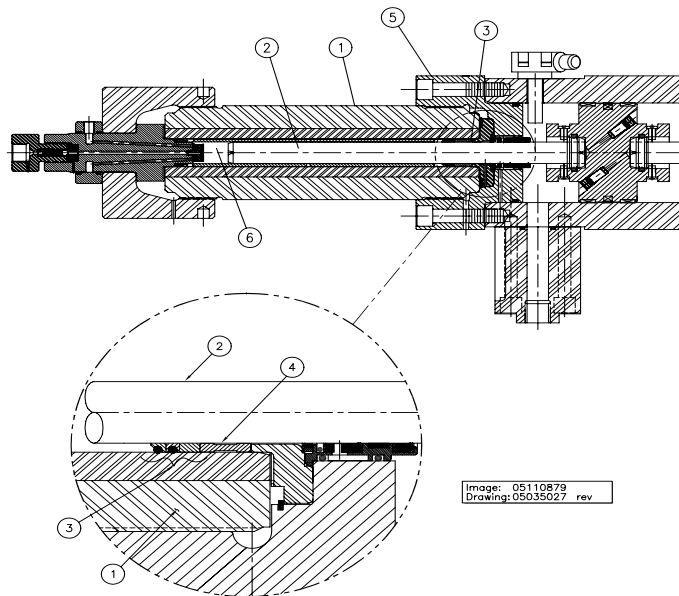

Item Description

- | | |
|---------------------------|-------------------|
| (1) Cylinder Body | (5) Cylinder Head |
| (2) Plunger | (6) Liner |
| (3) Plunger Seal Follower | |

7.3.5 Plunger

Plunger surfaces can become streaked with longitudinal scratches or flaws, the surface can become discolored or dull in appearance, or the outboard end can become smeared with stainless steel due to contact with the bore liner. If any of these conditions become severe, the plunger HP seal and possibly the hydraulic seals will leak excessively. Repair of plunger surface flaws usually cannot be accomplished on site. KMT Waterjet offers a plunger reconditioning service.

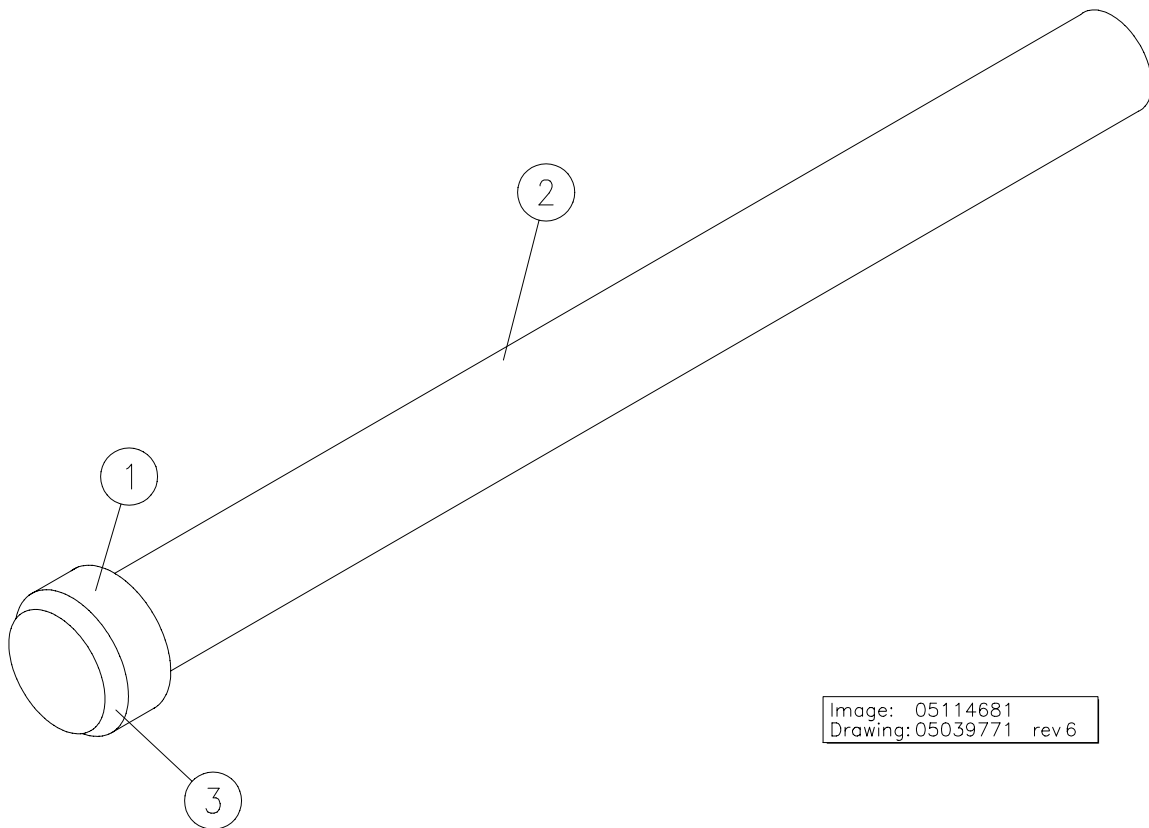
**Item Description**

(1) Plunger Button

(2) Plunger

(3) Button Chamfer

7.3.6 Hydraulic Seal Cartridge

1. Carefully remove worn seals and O-rings from cartridge by pushing them with a dowel or similar object. Remove seals positioned close to the open ends first, working toward the interior. Examine seals for unusual wear, deformation or cuts. Note any unusual buildups of solid material or debris causing possible leak paths.
2. Examine the cartridge body (1) surfaces for scratches, signs of metal-to-metal contact, deformation or other unusual wear.

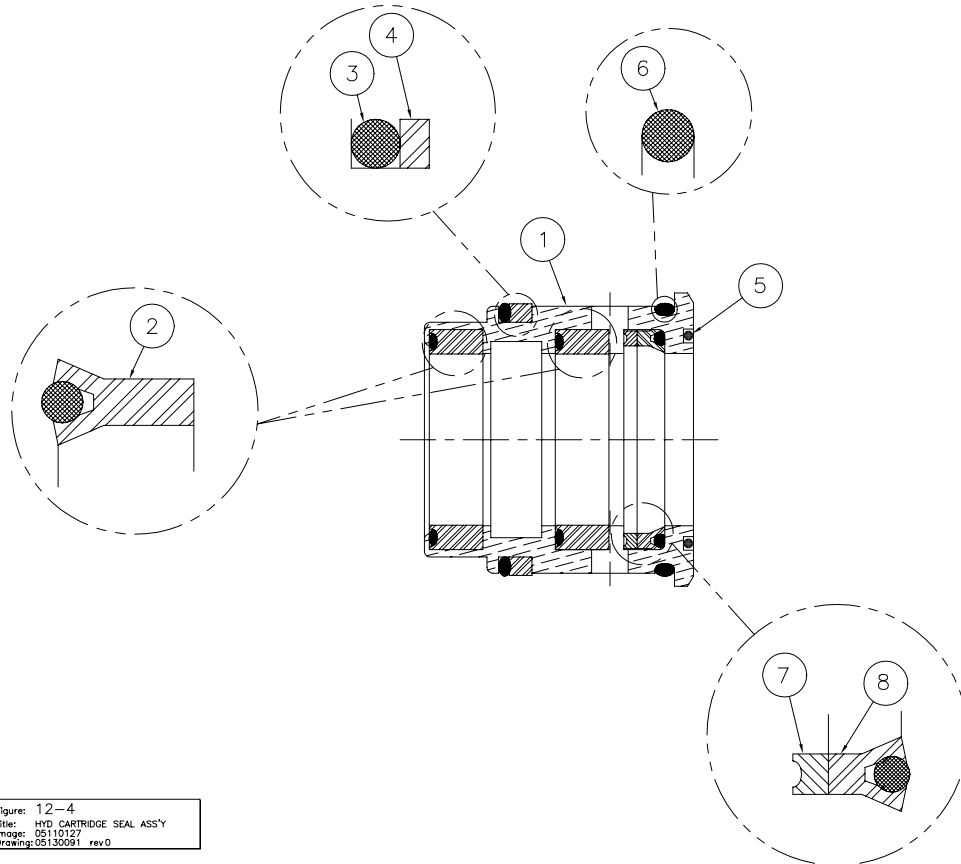

Figure: 12-4
Title: HYD CARTRIDGE SEAL ASS'Y
Image: 05110127
Drawing: 05130061 rev 0

Item Description

- | | | |
|--------------------|----------------|------------|
| (1) Cartridge Body | (2) U-cup Seal | (3) O-Ring |
| (4) Back-Up Ring | (5) O-ring | (6) O-Ring |
| (7) Back-Up Ring | (8) U-cup Seal | |

NOTE

It is important to examine the inside diameter surfaces of cartridge seal grooves for scratches, especially any scratches in the axial direction that might offer a leak path. Use caution during seal removal and installation to avoid scratching these surfaces. Do not use metal screwdrivers, wires, etc. to remove inside diameter seals. Plastic or wood should be used for seal removal and installation.

3. During seal installation, orient U-cup packing seals (2) (8) so that they match figure above.
4. Apply food grade grease to seals and cartridge seal components to aid in installation and seal seating. Use installation tool, if available, for installation of U-cup seals (2) (8). Verify that U-cup O-rings are in place in their respective U-cup seals after installation.

7.3.7 Hydraulic Piston

The hydraulic piston contains a seal assembly, bearing rings, pins and flat spring bands, and check valves. Bearing rings (10) provide wear contact between piston and cylinder ID. Plungers (12) are held in place by 6 each pins (2) per plunger. Pins (2) are maintained in place by flat steel band (6). Check valves (4) are mounted internal to the piston to vent unwanted hydraulic pressure to the piston opposite side. These check valves prevent hydraulic pressure from building behind the plunger button

Replace Piston Seal



CAUTION

Do not scratch bottom surface of piston seal groove. Scratches to the seal groove sides and/or bottom can result in a hydraulic leak.

1. Remove bearing rings (10) and worn seal ring assembly (9).

NOTE: Use a smooth, dull-edged blade made from brass or similar soft (relative to steel) material to remove and install seal assemblies.

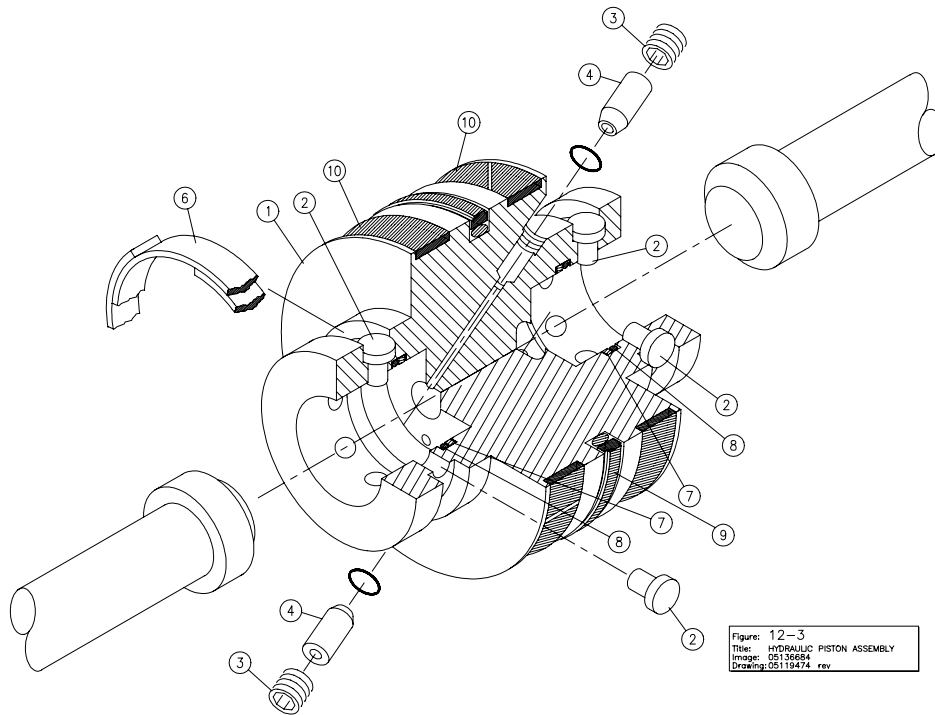

Figure: 12-3
Title: HYDRAULIC PISTON ASSEMBLY
Image: 05136684
Drawing: 05119474 rev

Item Description

1. Piston	5. Threadlocking Adhesive	8. O-ring
2. Pin (12 Each)	6. Flat Wire Snap Ring (2 ea.)	9. Seal Assy
3. Set Screw (2 ea.)	7. Backup Ring (2 ea.)	10. Bearing Ring (2 ea.)
4. Check Valve (2 ea.)		

2. With seal and bearings removed, inspect seal groove bottom for marks or scratches and residue buildup. Clean and /or repair groove surfaces as required.
3. Install replacement bearing rings (10).
4. Install replacement piston seal assembly (9). First install inner ring, taking care that this ring is not twisted after installation. Slide outer seal ring over metal edges, easing seal into place over inner ring.

NOTE: Heating the piston seal ring in hot water (150 degree F for 3-5 minutes) increases seal flexibility.

Service Piston Plunger Sockets (2 each)

1. Remove flat spring bands (6) and remove plunger retainer pins (2). Inspect pins and spring band for deformation or unusual wear. Clean and inspect pin holes in piston for unusual wear or hole deformation/enlargement.
2. Remove plunger button O-ring (8) and backup ring (7) (2 places), taking care not to scratch or otherwise damage seal groove surfaces. Clean and inspect seal grooves for residue buildup or surface marks that might cause seal leaks.
3. Inspect plunger button sockets for unusual wear.

NOTE: Plungers may make an indentation in the bottom of the plunger socket. The bottom of this socket may show the impression of the plunger on it due to the high contact forces between piston and plunger. This compression mark is normal.

Service Piston Internal Check Valves

NOTE: Check valve (4) servicing is not necessary unless there is suspicion of a problem. If the check valves (2 each) or piston internal passages must be serviced, seal and pin servicing is also recommended.

1. Check valves (items (4), 2 each) or cross-drill plug (11) removal may be necessary. Re-install using thread locking compound applied sparingly on the plug threads.



CAUTION

Excess compound may clog a check valve or block a drilled passageway.

- NOTE:** To avoid excess compound, position the plug or retainer on its Allen wrench, apply thread locking compound, then hold the plug/retainer horizontal on a paper towel while rotating the plug/retainer to wipe off excess thread locking compound.
2. Install O-ring in check valve cavity, positioning in hole bottom with pencil-like blunt instrument. Install check valve with chamfered end toward O-ring. Coat retainer (3) with thread locking compound. Then

thread retainer (3) over check valve cartridge (4). Allow 24 hours for thread locking compound to set.

3. Install plugs (11) in cross- drilled passages by applying thread locking compound to plug threads. Then thread plugs (2 each per hole), with the second plug acting to lock in the first. Allow 24 hours for thread locking compound to set.

Install Plunger Button Seals and Retainer Pins in Hydraulic Piston

1. Install new backup ring (7) and O-ring (8) in each internal groove in each plunger pocket (2 places).



Failure to install backup ring can result in plunger being forced out of plunger pocket.

2. Reinstall pins in piston, verifying that each pin moves freely without excess side play in its cavity.
3. Reinstall band (6) over pins. Repeat this process for the opposite piston side. With piston on bench, install plunger in each end of piston, checking snap-in feature of plunger attachment. Use plunger removal tool to verify that pins retract (release plunger) and close (retain plunger) in a uniform manner.

Install Hydraulic Piston Assy into Hydraulic Cylinder

NOTE: Piston seal assembly must be compressed before the piston assembly will slide into the hydraulic cylinder. A ring compression tool such as shown in the figure below is recommended.

1. Check that hydraulic cylinder bore is free grit, or contamination, and that the proximity switches are removed to prevent interference. Lubricate piston bearing and seal surfaces with FML-2 grease. Lightly lubricate 2-3 inches of cylinder (15) bore with same grease.
2. Fit or drive piston assembly into ring compression tool (20). Position compression tool with piston assembly over end of hydraulic cylinder. Using a plastic- faced hammer so as not to damage piston surfaces, gently drive the piston assembly into the hydraulic cylinder.
3. Remove seal compression tool, continue driving piston assembly into hydraulic cylinder until it is between the proximity switch holes. Continue intensifier re- assembly by installing cylinder heads, plungers, hydraulic seal cartridges, and HP components.

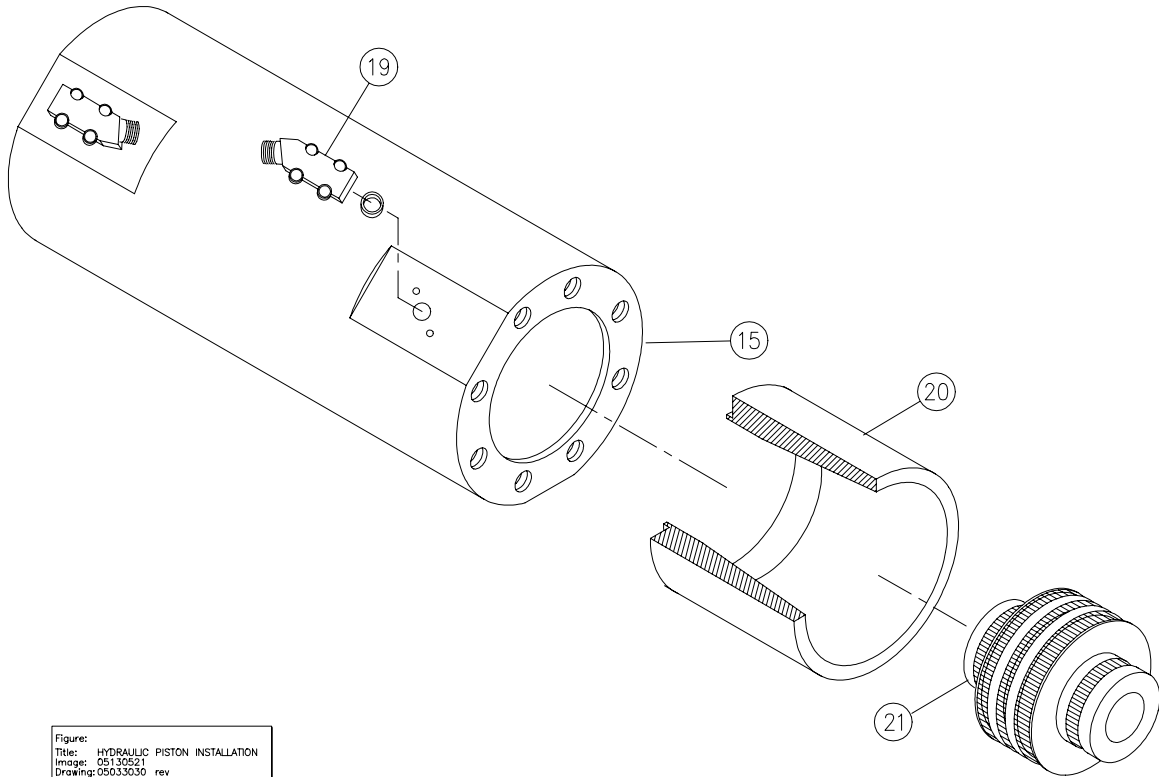

Figure:
Title: HYDRAULIC PISTON INSTALLATION
Image: 05130521
Drawing: 05033030 rev

(15) Hydraulic Cylinder
(20) Seal Ring Compression Tool (P460)

(19) Proximity Switch
(21) Hydraulic Piston Assy

7.3.8 Hydraulic Cylinder

The inside diameter surface of the hydraulic cylinder should be inspected for wear grooves and surface finish whenever the hydraulic cylinder heads are removed. Excessive grooving on this bore is indicative of piston seal wear.

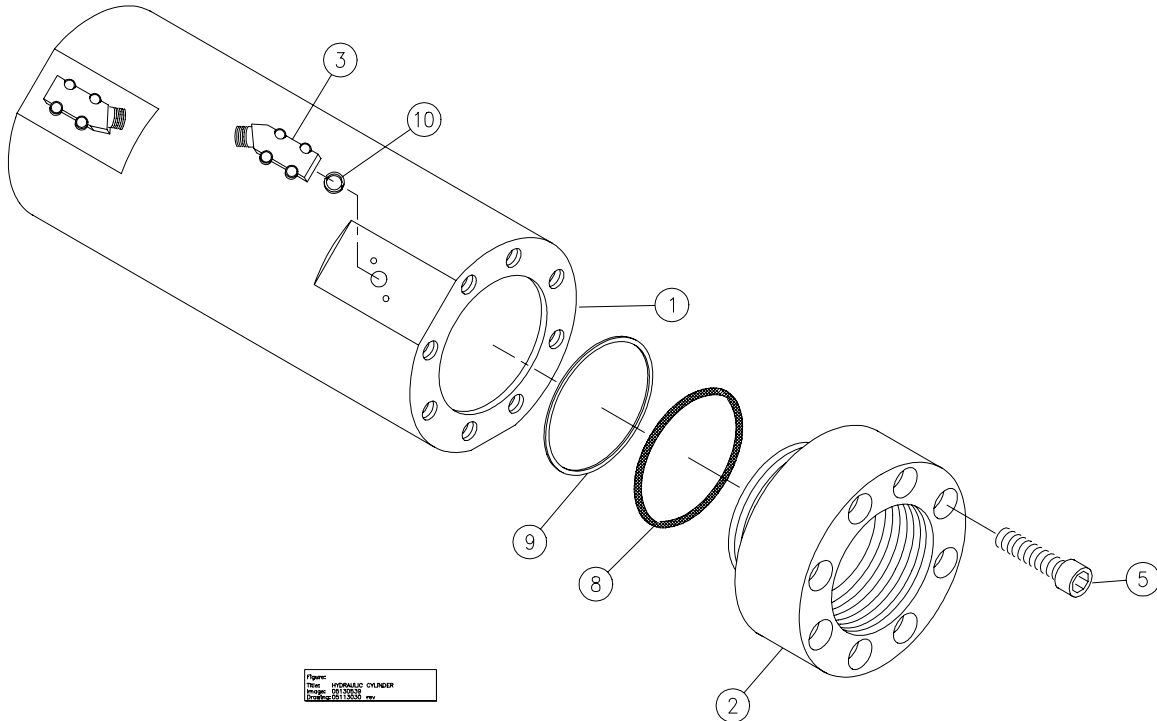
**Item Description**

- | | | |
|------------------------|-------------------|----------------------|
| (1) Hydraulic Cylinder | (2) Cylinder Head | (3) Proximity Switch |
| (5) Cap Screw | (8) Back-up ring | (9) O-ring |
| (10) Spacer | | |

7.4 HP Dump Valve

The dump valve assembly includes a normally open HP water valve, plus a solenoid operated air valve for the air actuator on the dump valve. Replacement parts for the HP valve are provided in the **Parts Lists** (Section 12, see Figure 12-7, “Bulkhead Piping Assy”).

7.5 HP Attenuator

There is no servicing of the HP attenuator at the customer level. The seals in the HP attenuator are tested at KMT Waterjet to high pressure in excess of operating pressure making disassembly difficult. In the event of a HP water leak of a HP attenuator, the attenuator should be replaced. The defective attenuator should be returned to KMT Waterjet for replacement or servicing.

Section 8 ELECTRICAL SYSTEM**8 Features**

The electrical system contains all functions necessary for turnkey operation. This includes the control and starter panel, intensifier reversal circuit.

The electrical enclosure, buttons, lights, and electrical harnesses into and out of this enclosure can be exposed to occasional water spray and dust per NEMA-12 standards.

8.1 Electrical Overview

There is only one electric motor on the SL-IV Waterjet Pump. The control voltage of 24vdc is furnished by the built-in power supply drawing its power from the motor's AC circuit.

8.1.1 Motor Starter Circuit

The SL-IV 11 kW (15hp) Waterjet Pump is powered by a standard Wye-delta starter circuit. The built in starter circuit includes the following:

- Manual disconnect with door handle interlock
- Over current protection
- Thermal overload devices.
- The hydraulic circuit automatically unloads hydraulic pressure to allow the motor to achieve full speed for approximately 2 seconds.
- The motor is also provided with terminal blocks for wire termination

8.1.2 Control Circuits and Logic

In order to prevent costly damage to the pump, automatic shutdown logic functions through the electrical circuits to shut down the pump.

- Low hydraulic reservoir level
- High hydraulic oil temperature

For more information on these conditions and recovery procedures, refer to Section 3, **Operation**, of this manual.

The following terminal blocks are provided in order to interface with the remote operator's station:

- Start
- Stop
- Emergency Stop (E-Stop)
- Pump RUN indicator light
- Pump malfunction light

8.1.3 Operation

During normal operation, the control panel shows operating messages and the RUN green light will be lit. After pulling the EMERGENCY STOP and CONTROL POWER ON pushbutton is pressed:

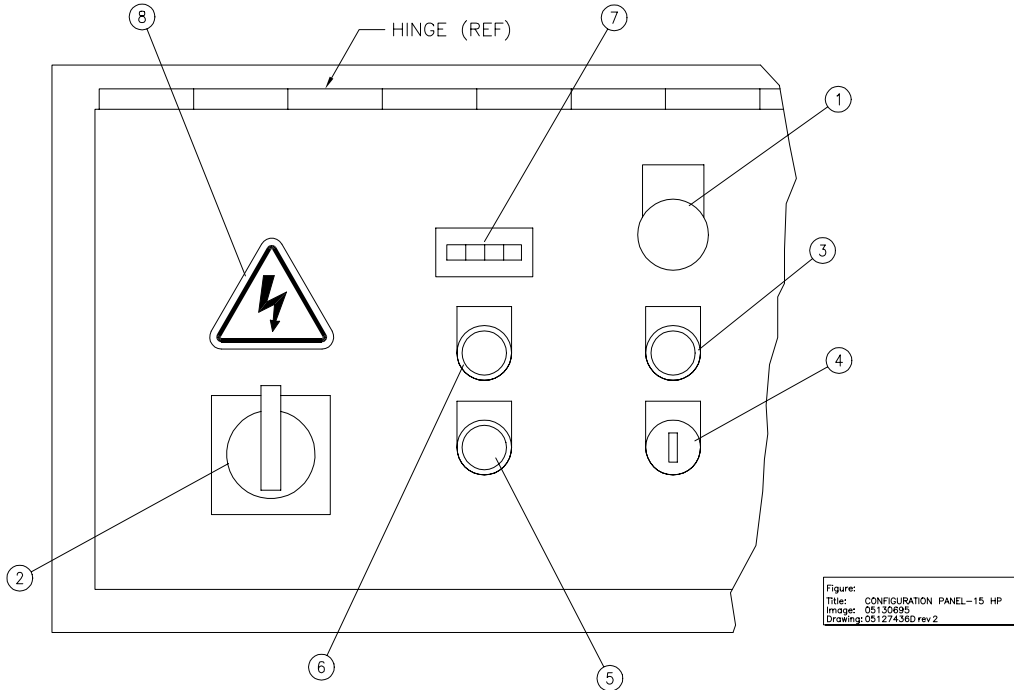

MOTOR STARTER/ INTENSIFIER CONTROL PANEL, SL-IV/15hp

Item	Item Description	Item	Item Description
1	Palmbutton—Emergency Stop	5	Stop Pushbutton, Lighted (Red)
2	Handle—Power Disconnect	6	Start Pushbutton, Lighted (Green)
3	Pushbutton—Control Power Reset, Lighted (White)	7	Hourmeter
4	Selector Switch—Local/ Remote (keyed)	8	Decal—Shock Hazard Warning

During normal operation the control power reset light (white), and the START pushbutton light (green) are illuminated. If the SL-IV Pump shuts down due to one of the automatic features, the control power reset light and STOP pushbutton light (red) will be illuminated. High oil temperature and low oil level are the two automatic shutdown circuits. When either automatic shutdown condition is cleared, for example, oil temperature is reduced below the temperature switch limit, then the red light is no longer illuminated. At this point, the SL-IV Pump can be restarted.

The high-pressure dump valve is powered on and closes.

NOTE
The high-pressure dump valve will not close if the air supply is OFF.

After pressing the START Pushbutton:

- The unloading valve delays hydraulic pressure build-up while the motor starter circuit accelerates the motor to normal rotating speed.
- The intensifier assembly starts operating. Reversal position is sensed by proximity switches, which send signals to the relay logic inside the control panel. The relay logic activates the opposite solenoid on the directional control valve.

8.2 Maintenance Overview

Electrical components require minimum attention and service.

8.2.1 Proximity Switch Service

If the pump quits pumping water, the proximity switch may need to be replaced. Check the LED lights on the switch.

Symptoms of a failed proximity switch are (1) the LED lights do not change state (indicating not sensing the piston) or (2) the LED lights are continuously flashing. Replace the switch when failure occurs.

- | | | | | |
|--------------------|--------------------------|---------------------------|---------------------|------------------|
| Components: | (1) Intensifier Assembly | Recommended Tools: | Torque Wrench | |
| | (2) Electrical Harness | | Allen (hex) Wrench, | |
| | (3) Proximity Switch | | M5 | |
| | (4) Hydraulic Cylinder | | Parts: | Proximity Switch |
| | (5) Piston | | | |

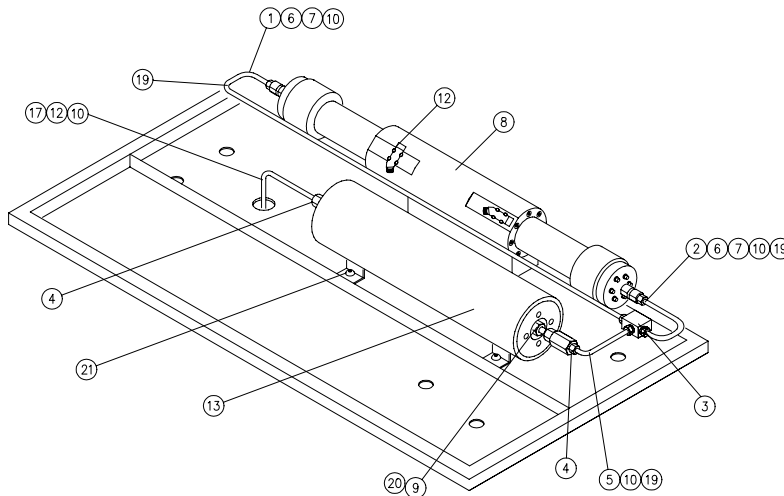
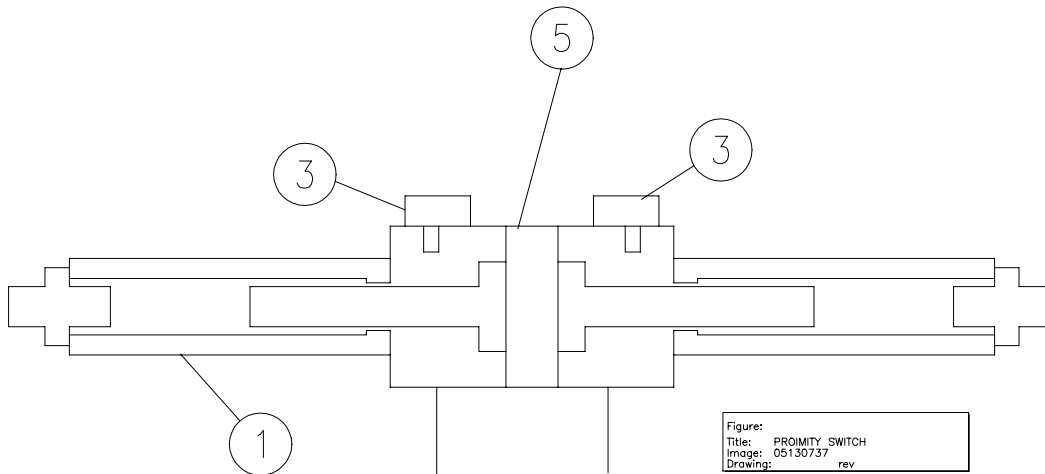

Figure:
Title: HIGH PRESSURE WATER ASSEMBLY
Image: 05130703 Rev 0
Drawing: 05081104 Rev 0

- | | | |
|---------------|-----------------------|----------------------|
| 1 HP Tube | 6 Gland Nut - HP Tube | 12 Proximity Switch |
| 2 HP Tube | 7 Collar - HP Tube | 13 HP Attenuator |
| 3 Tee Fitting | 8 HP Intensifier | 19 Conduit, Flexible |
| 4 HP Fitting | 9 HP Fitting | 20 Enclosure End |
| 5 HP Tube | 10 Ferrule, .25 Hose | 21 Spacer |

**Replace Proximity Switch**

1. Turn off waterjet pump, disconnect and LOCKOUT electric power.
2. Disconnect cable.
3. Unscrew bolts, remove proximity switch.
4. Install new switch. Install bolts.
5. Torque bolts to 16-18 Nm (140-160 in-lbs.).

Section 9 HYDRAULIC SYSTEM**9 Hydraulic System**

The hydraulic system drives the water intensifier assembly to produce a HP waterjet cutting stream. The hydraulic system is composed of a variable- displacement; pressure- compensated axial piston pump, driven by an electric motor.

The hydraulic system is designed to provide sufficient hydraulic oil flow at sufficient pressure to supply the intensifier, at its specified maximum output conditions of flow and pressure. Refer to Section 11, **Specifications**.

9.1 Overview

The hydraulic system includes two hydraulic circuits each with its own pump:

- Main hydraulic power control circuit which uses the piston pump (discussed in this section), and the
- Recirculation system which uses a gear pump mounted in tandem with the piston pump (discussed in Section 10, **Recirculation System**).

A single hydraulic pump and a directional control valve (DCV) are used to control the intensifier hydraulic cylinder. The hydraulic manifold, which includes the solenoid-operated DCV, is mounted beneath the intensifier hydraulic cylinder. The hydraulic system also includes plumbing to connect pump, valve manifold and reservoir.

9.1.1 Features

Features of the hydraulic power and control system are listed below:

- **Hydraulic unloading** during motor start.
- **Hydraulic 4-way valve** – directional control valve (DCV)–solenoid-operated. Used for HP cylinder shifting.
- **Close - coupled motor/hydraulic pump** – pump mounts directly to the motor, providing a compact pump/motor assembly, reducing footprint of the overall waterjet pump package. The pump is directly coupled to the motor rather than a conventional standoff housing and shaft coupling assembly.
- **Reference hydraulic gage** – used for adjusting pressures in the pump compensator. Displays hydraulic pressure and provides an indication of water pressure.
- **Built in hydraulic oil drip pan** – allows for the spills to be contained within the machine while addressing environmental issues of mixing water and oil.

- **Pressure adjustment control** – allows for infinite pressure settings though out the entire pressure range for flexibility.

9.1.2 Components

Following are the hydraulic system components:

NOTE

The main pump is direct-mounted to the motor. The main pump pressure control is adjusted at the pump compensator.

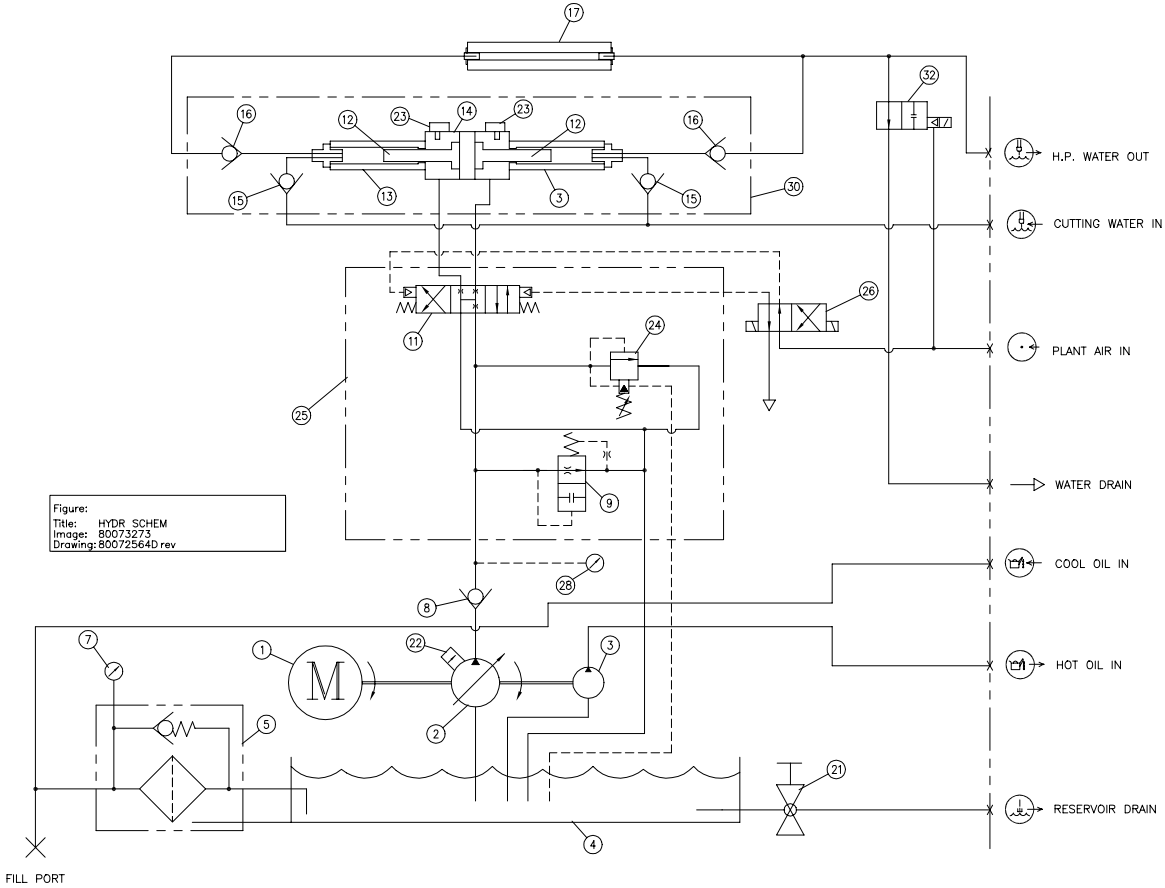

1	Electric Motor, 15 hp
2	Piston Pump
3	Gear Pump
4	Hydraulic Reservoir
5	Filter Housing
7	Pressure Gage
8	Check Valve
9	Unloading Valve-- Startup

11	Hyd Directional Control Valve
12	Plunger
13	HP Cylinder
14	Hyd Cylinder-Intensifier
17	HP Attenuator
22	Pressure Compensator Control

23	Proximity Switch
24	Main Relief Valve
25	Hydraulic Manifold
26	Solenoid Valve, Pneumatic
28	Pressure Gage
30	Intensifier Assembly

9.2 Operation

The hydraulic system operates at its adjusted pressure setting up to the maximum flow capacity of the variable displacement piston pump. During motor start the piston pump flow is ported to reservoir to reduce load on the motor.

The electric motor (1) drives the piston pump (2) and gear pump (3). See Section 10 **Recirculation** for discussion of the gear pump circuit. The hydraulic manifold (25) is mounted to the underside of the intensifier assembly (30). The flow from the piston pump (2) passes through check valve (8) to the directional control valve (11), and the directional control valve sends the flow to one end of the hydraulic cylinder (14) until the piston activates the proximity switch (23) at the end of the stroke. The activated proximity switch sends an electrical signal to the pneumatic directional control valve (26) that in turn shifts the hydraulic directional control valve (11). The hydraulic valve shifts to reverse direction of movement of the piston (29) until activating the opposite end-of-stroke proximity switch.

9.2.1 Hydraulic Pressure Compensation

A pressure compensation (22) feature on the variable- displacement, piston pump (2) maintains constant hydraulic operating pressure even under variable flow demands. When the HP water flow is blocked or restricted, the piston pump delivers only enough hydraulic oil to maintain compensator (22) set pressure. If HP water flow is high, for example, the nozzle orifice is too big, then the pressure compensator commands full flow capacity from the piston pump.

9.2.2 Hydraulic System Pressure Protection

Besides the pump compensator (22), the hydraulic system pressure is limited by the main relief valve (24). The operating hydraulic pressure is indicated by hydraulic gage (28).

Control	Valve	Pressure Adjustment		Hyd. Pressure Bar (psi)	
		Increase	Decrease	Maximum	Minimum
Compen- sator Pressure	22	Clockwise	Counterclockwise	207 (3,000)	1.7 (25)
Main Relief	24	Fixed	Fixed	234 (3,400)	(Not applicable)

9.2.3 Motor Startup

The electric motor (1) starts in two stages (Wye-Delta). During the initial (Wye) stage, piston pump (2) pressure is maintained low to reduce torque load on the motor. Piston pump depressurization is accomplished by delayed closing of check valve (9) located in the manifold (25). After several seconds, flow through orifice (10) builds pressure behind the check valve (9), closing it and directing pump flow into the main working circuit. By the time this hydraulic shift occurs, the motor will have shifted to full speed (Delta), capable of full torque.

9.3 Motor/Hydraulic Service Maintenance**9.3.1 Pump Compensator Adjustment**

Pressure for HP water is raised or lowered by adjusting the compensator screw (34) on the piston pump. Note that there are 2 adjustment screws, inner and outer, on the same compensator assembly. The inner adjustment screw (34) can be adjusted to pressures up to 207 bar (3,000 psi) and is used for making all pump adjustments. The outer adjustment screw (35) pre-set at the factory and should not require re- adjustment.

NOTE:

The outer pressure adjustment screw (35) is set in the range of 10-22 bar (145-320 psi). Standard setting is 20 bar (290 psi).

Use a 3mm hex Allen wrench (31) to turn the compensator adjustment screw (34). Adjust pressure while the HP water is blocked and the pump is producing little or no flow. Loosen the jam nut (33). Rotate the screw clockwise to increase pressure. Replace the cap nut (32) over the adjustment screw after changing the pressure setting, otherwise hydraulic oil will leak from the compensator.

NOTE:

Do not adjust the compensator pressure control to pressures greater than 207 bar (3,000 psi). Doing so will cause the main relief to open, limiting hydraulic pressure to 234 bar (3,400 psi). Also due to repeated opening of the main relief valve the hydraulic oil may heat excessively.

The hydraulic oil filter should be checked daily and replaced when excessive pressure drop is indicated during normal operating conditions. Replace filter element when the pressure reading is 1.4 bar (20 psi) above normal when at operating temperature. Maximum normal pressure is 1.7 bar (25 psi). The hydraulic oil should be replaced every 2000 hours or yearly, whichever occurs first. For hydraulic oil and filter maintenance, see Section 10, **Recirculation System**.

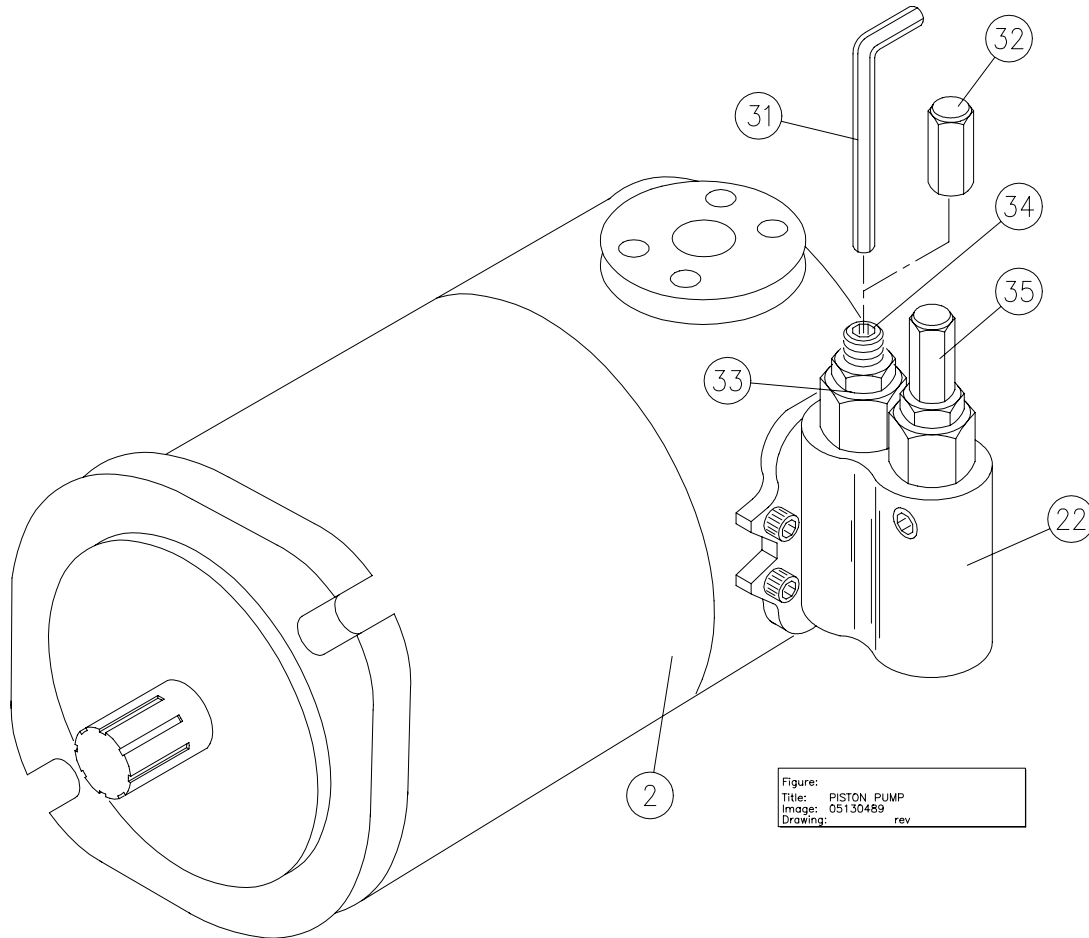

2	Piston Pump	32	Cap Nut
22	Compensator	33	Jam Nut
31	Allen Wrench (3mm)	34	Adjustment Screw
		35	Outer Adjustment Screw

The hydraulic system components that require periodic maintenance are the motor and the pump compensator. The motor needs to be serviced every 5000 hours of use. The operating pressure settings of the manifold need to be checked daily and adjusted if necessary.

Recommended Tools:

Manual Grease Gun
Open End Wrench 14mm (9/16")
Rags

Parts:

Bearing Grease, SRI #2 or equivalent

9.3.2 Pump /Motor Coupling Service

The main pump is connected to the electric motor by means of a keyed shaft close coupling. If the pump and motor must be separated, then it is necessary to use the special lubricant specified in the parts list.



Failure to use the proper lubricant could result in excessive wear of/ damage to the shaft coupling.

9.4 Pump Service

9.4.1 Pump Case Prefill

Whenever the piston pump or the reservoir has been serviced, emptied, removed/ replaced, etc. the pump should be filled with oil to purge air from the case. One means of assuring the pump case is purged of air is to remove an upper plug (note that there are 2 case drain plugs on the pump) long enough to allow some hydraulic oil to exit the port, then re-install the plug.



Failure to remove trapped air from the pump case will result in permanent damage to critical rotating components of the pump.

9.4.2 Seal Kits

Oil leaks can occur as a result of seal damage or deterioration at the pumps. Repair seals are specified in the **Parts List** (Figure 12-10) for various shaft and static joints between pumps, motors, etc.

Section 10 RECIRCULATION SYSTEM**10 Features**

The recirculation system keeps the hydraulic oil at operating temperature while using the minimum amount of cooling water flow. The system also provides the necessary oil conditioning and filtration to maintain oil cleanliness. The conditioning of the hydraulic oil includes cooling it, cleaning it, and together with the hydraulic reservoir, removing air bubbles entrained in the oil due to agitation and turbulent flow in the main pump circuit.

10.1 Components

The cooling and filtration system (recirculation system) is equipped with the following:

- **Recirculation pump** (gear-type)–which receives oil from the hydraulic reservoir
- **Heat exchanger** - cooling water is controlled by the water modulating valve
- **Oil filter assembly** - includes a gage to show the filter element condition. It also includes a bypass or relief valve, should the filter element be allowed to become entirely clogged with dirt/contaminants.

10.2 Operation

The recirculation pump takes oil from the hydraulic reservoir and pumps it to the oil- to- water heat exchanger, then to the oil filter and back to the reservoir.

Condition of the hydraulic filter is determined by analyzing gage pressure. Hydraulic oil is pumped into the reservoir through a tee fitting near the top of one end of the reservoir. On the 15 hp SL-IV fill oil entering the reservoir does not pass through the filter. Use of an oil filter/ transfer cart for filling is recommended to assure fluid cleanliness.

Operating Temperature Adjustment

The operating temperature is adjusted by turning the water modulating valve (19) adjusting knob with a flat blade screwdriver. Clockwise increases the oil temperature.

The water modulating valve regulates the cooling flow that enters the heat exchanger (6) and then discharges to the drain.

The operating oil temperature is factory set at 46°C (115°F) based on the temperature and flow of cooling water at the factory. Field adjustment may be necessary.

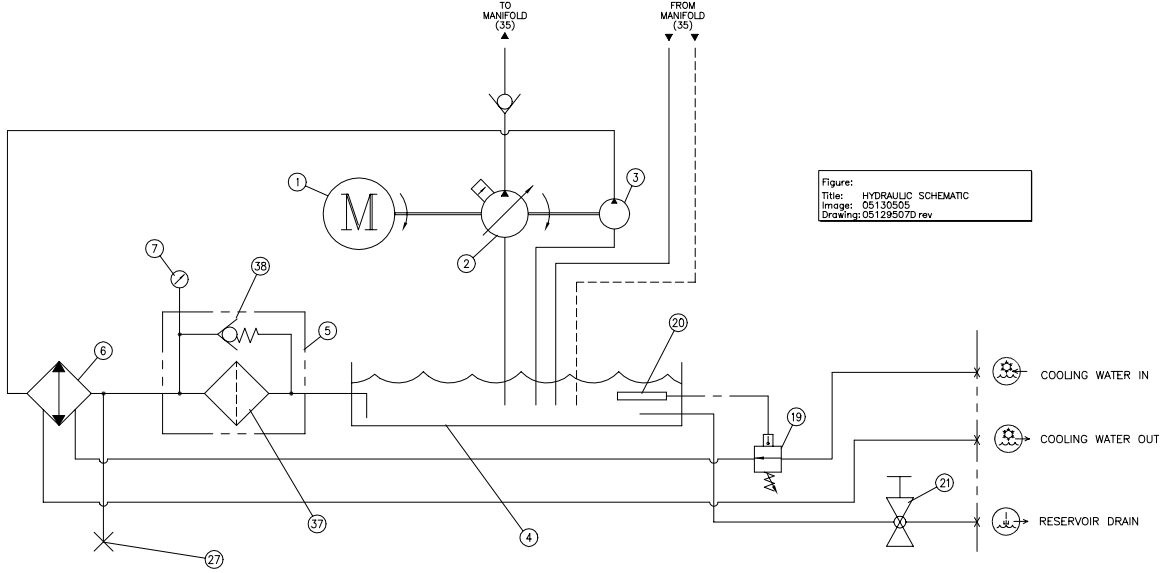

1	Electric Motor, 15 hp	19	Water Modulating Valve
2	Piston Hydraulic Pump	20	Temperature Sensor Bulb
3	Gear Hydraulic Pump	21	Drain Valve, Reservoir
4	Hydraulic Reservoir	27	Fill Port, Hydraulic Reservoir
5	Hydraulic Filter Housing	37	Filter Element
7	Hydraulic Pressure Gage	38	Bypass, Filter

10.3 Filter Bypass Pressure Protection

Excessive pressure drop across the hydraulic filter is prevented by relief valve (38) located on filter head (5).

Control	Valve	Adjustment		Setting	
		Increase	Decrease	Maximum	Minimum
Oil Temperature	19	Clockwise	Counter-clockwise	52°C (125° F)	41°C (110° F)
Oil Pressure	38	Fixed	Fixed	4.2 bar (60 psi)	3.8 bar (55 psi)

10.4 Maintenance Overview

During normal operating condition, the oil will be maintained at the correct operating temperature.

In order to get the best value from the hydraulic system (including the recirculation system) one should change the filter element when it indicates that it is time. The hydraulic oil should be changed after 2,000 hours or 1 year of service (whichever comes first) or whenever a fluid sample indicates that it is contaminated and beyond being fixed by simply operating the filter.

Parts: Hydraulic Oil:
General service, use Mobil #DTE Heavy Medium, No. 021029
Food service, use AMOCO #FG68EL
Oil with additives such as zinc diophosphate for antiwear are not recommended because of reaction with water.

Tools: Open End Wrench, 1-1/4"
Rags
Container to collect oil
Oil filter/ transfer pump with 3/4" hoses. Inlet hose with 1/2" male pipe connector, and pump discharge hose with 3/4" female JIC connector.

Oil Filter

Replace filter element when the pressure reading is 1.4 bar (20psi) above normal when at operating temperature. Maximum normal pressure is 1.7 bar (25psi).

Components: (1) Oil Filter Head
(2) Element
(3) Pressure Gage

Parts: Element
Tools: Filter Wrench
Rags
Container to collect oil spills

Replace Oil Filter

1. Unscrew element from filter head with the filter wrench.
2. Oil gasket of new element.
3. Screw new element on head.
4. Start pump and check for leaks.

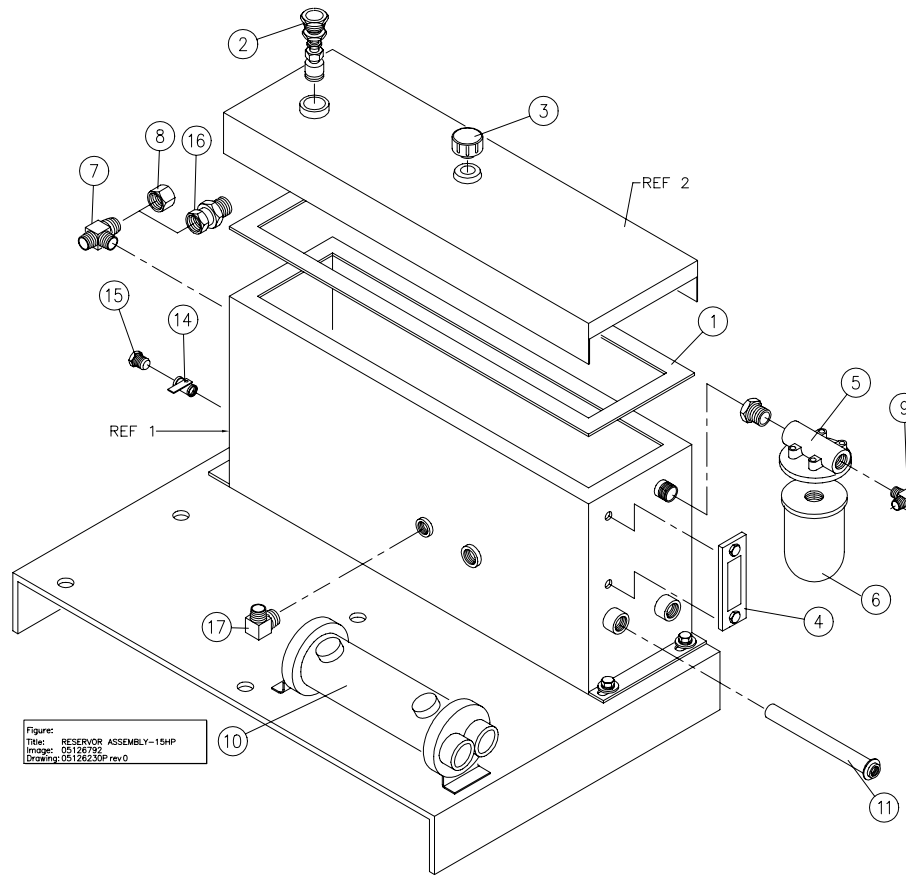

Figure:
Title: RESERVOIR ASSEMBLY-15HP
Image: 05128732
Drawing: 05128230P rev 0

1	Gasket, Hydraulic Reservoir Cover	10	Heat Exchanger
2	Sensor, Oil Temperature and Low Level	11	Well, Temperature Sensor Bulb
3	Breather, Air	14	Drain Valve
4	Sight Gage (with thermometer)	15	Plug
5	Filter Head	16	Adapter, Fill Port
6	Filter Element	17	Elbow
7	Tee Fitting, Fill Port	Ref. 1	Reservoir Tank
8	Cap, Fill Port	Ref. 2	Reservoir Cover
9	Elbow		

Oil Reservoir

The oil reservoir is equipped with the following:

- Visual temperature and level indicator
- Air breather and filter that prevents dirt from being sucked into the reservoir whenever the oil level drops, then allows air to escape when the level rises
- Drain valve, and
- Fill components.

The fill components consists of the Oil Filter Head, Fill Port, and the Fill Port Cap.

**WARNING**

The breather is not a fill component, and must not be used as a fill point.

Replace Hydraulic Oil

1. Drain the reservoir, by connecting the inlet hose of the oil filter/ transfer pump to the drain valve. Open valve and pump oil to container.
2. Close hand valve, remove oil filter/ transfer pump inlet hose from hand valve.

NOTE

Never assume a new drum of oil is free of damaging contaminants. Typically, oil from a new drum does not meet the hydraulic system cleanliness requirements. For this reason it is important to use the oil filter/ transfer pump, which forces oil through the return filter into the reservoir.

3. Remove cap from fill port.
4. Connect oil filter/ transfer pump discharge to fill port. This will assure clean filtered oil is pumped into the reservoir.

**CAUTION**

Oil must be filtered through an equivalent filter such as a 10 micron filter element or see filter element in figure 12 in section 12. Failure to do so will cause damage to the primary hydraulic components, voiding the warranty.

5. Check oil sight gage to assure proper fill level. Remove hose, cap fill port.
6. Remove the plug of the main hydraulic pump case and make sure the case fills with oil. With the plug removed, head pressure from the reservoir will force oil into the pump case.
7. Run pump following initial start-up procedure. This will assure the system is filled.
8. Check oil sight gage. Add oil if necessary.
9. Disconnect oil filter/ transfer pump discharge hose, install fill port cap.

**CAUTION**

Failure to fill the pump case with oil will damage the pump due to air becoming trapped inside.

SECTION 11 SPECIFICATIONS

Specifications

Following are the specifications for the SL-IV 11kW(15hp) Waterjet Pump. Included are the specifications for the equipment, torque, cutting water, cooling water, and the maximum quantity of orifices that can be supported.

Equipment Specifications

SL-IV Waterjet Pump Size	11 (15)	kW (hp)
Installation location	Indoors	
-Air borne dust/contaminants	Minimal	
Ambient temperature		
-Minimum storage	2(36)	°C(°F)
-Minimum operating	5(40)	°C(°F)
-Maximum operating	40(104)	°C(°F) (see note [1])
Maximum Relative Humidity		(see note [2])
-At Maximum Operating Temp.	95%	
Electrical		(see note [3])
-Motor type	TEFC	(see note [4])
Voltage / Service Amps		Volts/Phase/Hertz/Amps
	200/3/50	42
	208/3/60	41
	240/3/60	38
	400/3/50	21
	415/3/50	20
	480/3/60	19
Sound Level	75.5	dB(A)
Controls		
-Voltage	24	volts, DC
-Power Supply	5	amps, DC
-Safety shutdown switch settings		
High oil temperature	62 (144)	°C (°F)
Low oil level	30(8)	liters (gal).
Hydraulic System		
- Oil tank capacity	53(14)	liters (gal)
- Recommended oil type		
Regular applications	Mobil, DTE Heavy Medium, # 021029 (# 05022702)	
Food applications	AMOCO #FG68EL (# 49835762)	
- Hydraulic oil operation		
Minimum temperature	15(60)	°C(°F)
Maximum temperature	65(150)	°C(°F)

- Note** [1]: Based on motor nameplate data, oil temperature must be maintained within operating specifications.
 [2]: When relative humidity is above 50%, frequently check oil in tank for water content.
 [3]: Not all motor voltages are readily available, check with factory for availability.
 [4]: Totally enclosed fan cooled.

SL-IV Waterjet Pump Size	11(15)	kW (hp)
Optimum temperature	46(115)	°C(°F)
Hot oil shutdown	62(144)	°C(°F)
Fluid Filtration Rating	Beta 10 >/= 100	Note [6]
Fluid Cleanliness Level	17/14	Note [7]
-Hydraulic Pump Type	Piston	
Displacement	Variable	
Pressure	Compensated	
Flow rate	38.7(10)	l/min(gpm)
-Hydraulic Settings (factory)		
Main Relief Valve	234(3400)	bar (psi) Note [8]
-Hydraulic oil cooling		
Total heat rejection	2.25 (3)	kW (hp)
Cooling fluid requirements at inlet fluid temperature	18 (65)	°C (°F)
Maximum cooling flow	TBD	l/min (gpm)
Maximum inlet pressure	6.9(100)	bar (psi)
Pressure drop	2 (30)	bar (psi)
Cutting Water "IN"		
-Minimum inlet pressure	2.4(35)	bar (psi)
-Maximum inlet pressure	7 (100)	bar (psi)
-Maximum outlet pressure	8.3 (120)	bar (psi)
-Maximum inlet temperature	29 (85)	°C (°F)
-Optimum inlet temperature	18 (65)	°C (°F)
Cutting Water Out		
-Maximum flow rate	1.2 (0.3)	l/min(gpm)
-Minimum outlet pressure	345 (5,000)	bar (psi)
-Maximum cont. outlet pressure	3,800 (55,000)	bar (psi)
-Intermittent outlet pressure	4,100 (60,000)	bar (psi)
Compressed Air		
-Flow rate maximum	0.028 (1.0)	m ³ /min(cfm)
-Inlet pressure range	5-6 (75-85)	bar (psi)
Service Connections		
-Cutting water in	1/2" NPT	
-Cutting water out	9/16"	60,000 psi HP fitting
-Cooling water in	1/2" NPT	
-Cooling water out	1/2" NPT	
-Plant air in	1/4" NPT	
-Cutting water drain	1/2" NPT	
-Oil tank drain valve	1/2" NPT	
-Oil tank fill port	3/4" male JIC	

Note [6]: Beta filtration rating—Interpreted as: 100 particles per ml larger than 10 microns upstream of the filter for each particle (per ml) greater than 10 microns downstream of the filter.

Note [7]: ISO-4406 fluid cleanliness ratings—17 ~ < 1,300 particles per ml > 25 microns // 14 ~ < 160 particles per ml > 15 microns.

Note [8]: Relief Valve is TUV certified for pressure setting indicated, tamper-proof lock wired.

Torque Specifications

Recommended Torque Values–Hydraulic Intensifier and HP Connections



Do not exceed torque values, excess torque can cause component damage or failure with potential hazards to equipment and personnel.

Item	Torque Nm (ft-lb)	Wrench mm (inch)
Hydraulic Intensifier		
Hydraulic Cylinder		
Capscrew, cyl head	190-210(140-155)	M12 hex
Proximity switch	17(13)	M5 hex
Seal Head		
Gland Nut	88(65)	30 (1-3/16) Crowfoot
HP Tubing Nut	67(50)	(13/16) Crowfoot
Pneumatic Valve		
3/8" Inlet	67(50)	(13/16) Crowfoot
1/4" Outlet	34(25)	(5/8) Crowfoot
H P Fitting Gland Nuts		
1/4" Nut	34(25)	(5/8) Crowfoot
3/8" Nut	67(50)	(13/16) Crowfoot
9/16" Nut	149(110)	(1-3/16) Crowfoot

NOTE

Measurements are made with lubricated components and a calibrated torque wrench. Inconsistencies in wrench settings, lubrication, and technique, may not produce a leak tight seal. If leakage persists, increase the torque until the components seal, do not exceed a value 15% greater than shown. If leakage persists there is a component problem. **EXCESSIVE TORQUE MAY DAMAGE OR REDUCE THE LIFE OF COMPONENTS.**

Use of an antiseize thread lubricant, like High Purity Goop (P/N 10084440) is highly recommended for tightening of stainless steel HP water fittings.

A torque wrench kit is available from KMT Waterjet. (P/N 49895436).

Cutting Water Specifications

The cutting water supply to the waterjet pump must meet the following specifications. High concentration of dissolved solids, especially calcium, silica, and chlorides, will affect high pressure component life. A water analysis will indicate the type of water treatment necessary.

Water Quality Parameters	Minimum Requirement	Better	Best
Alkalinity (mg/l)	50	25	10
Calcium (mg/l)	25	5	0.5
Carbon Dioxide (mg/l)	0	0	0
Chloride as Cl (mg/l)	100	15	1
Free Chlorine (mg/l)	1	1	0.05
Iron as Fe (mg/l)	0.2	0.1	0.01
Manganese as Mn (mg/l)	0.1	0.1	0.1
Magnesium as Mg (mg/l)	0.5	0.1	0.1
Nitrate (mg/l)	25	25	10
Oxygen (mg/l)	2	1	0.1
pH Value	6.5 - 8.5	6.5 - 8.5	6.5 - 8.5
Silica (mg/l)	15	10	1
Sodium (mg/l)	50	10	1
Sulfate (mg/l)	25	25	1
Total Dissolved Solids (mg/l)	200	100	5*
Total Hardness as CaCO ₃ (mg/l)	25	10	1
Turbidity (NTU)	5	6	1

* Do not reduce beyond this amount or the water will become too aggressive.

Cooling Water Specifications

Depending on the type of cooling system (closed recirculation, once through, etc.), the following common problems can be experienced:

Closed recirculation:

- Corrosion
- Fouling

Once through:

- Corrosion
- Fouling
- Scale
- Microbiological

Scale control is the most common problem, and is the result of insoluble matter deposited on the heat transfer surface. Calcium carbonate is the primary cause of scale when calcium bicarbonate breaks down. As the temperature of the water increases it becomes less able to hold carbonates in suspension.

To predict the tendency of scale formation, the Langelier's saturation index can be used as a guide.

Saturation Index = pH-pH_s where pH_s is calculated at saturation with calcium carbonate.

A positive index indicates a tendency to deposit calcium carbonate, the higher the positive value, the higher the scale formation. A zero index corresponds to water that is in equilibrium with respect to calcium carbonate.

Orifice Support Capacity

The SL-IV Waterjet Pump supplies high pressure (HP) water up to 3,800 bar (55,000 psi). The following table shows size, ratings, and maximum quantity of orifices that can be supported.

Rated power kW(hp)	Pressure Bar (Psi)	Flow lpm (gpm)	Qty	Orifice Diameter mm (inch)
11 (15)	3,800 (55,000)	1.2 (0.30)	1	0.20 (0.008)
			1	0.17 (0.007)
			1	0.15 (0.006)
			2	0.12 (0.005)
			3	0.10 (0.004)
22 (30)	3,800 (55,000)	2.5 (0.65)	1	0.28 (0.011)
			2	0.17 (0.007)
			4	0.12 (0.005)
37 (50)	3,800 (55,000)	3.8 (1.0)	1	0.35 (0.014)
			2	0.28 (0.011)
			4	0.17 (0.007)
			8	0.12 (0.005)

PARTS LISTS

For:

**SL-IV 15 hp HSEC
High Pressure Waterjet Pump
Version 1.0**

208/230/480/3 ϕ /50-60 Hz Intensifier

To contact the KMT Waterjet Spare Parts Department:

USA Parts Department
KMT Waterjet Systems
P.O. Box 231
635 West 12th Street
Baxter Springs, KS 66713-0231
USA
Phone: (620) 856-2151
Fax: (620) 856-5050
E-mail: Wj.service@kmtwaterjet.com

Europe: Technical Manager
KMT Waterjet Systems GmbH
Wasserstrahl-Schneidetechnik
Auf der Laukert 11
D-61231 Bad Nauheim
Germany
Phone: +49-6032-997-117
Fax: +49-6032-997-270
E-mail: order.service@kmt-waterjet.com

SECTION 12 PARTS LISTS

12.1 General

This section contains parts lists for service procedures and part identification, along with electrical and plumbing schematics of the SL-IV 15 hp Waterjet Pump. The reader can use these parts lists to identify the part on a drawing, and then find the part number and part description corresponding to the drawing balloon number. Replacement parts can be ordered with this part number information.

12.2 Part Nomenclature

The following abbreviations and numerical sizes are used for part descriptions in these parts lists:

Table 12-1 Part Description Abbreviations and Nominal Size Guide

Item	Description	Item	Description
Assy	Assembly	mm sq.	Square millimeters
1/4, 9/16, 3/4	Nominal sizes in fractions of an inch, e.g., 1/2 NPT ~ 0.50-inch national pipe thread, or 9/16 HP tube ~ 0.56-inch OD HP tubing or tube fitting	JIC	37-degree flared, threaded hydraulic fitting, JIC standard, typically used on hydraulic hose end connections.
Hyd	Hydraulic	Dia	Diameter
ID or OD	Inside diameter or outside diameter	Deg	Degree
psi or ksi	Pounds per square inch or thousands of pounds per square inch	-4,-8,-12	Hydraulic fitting nominal size, in 1/16 thd's of an inch, e.g., 1/2 OD tube ~ -8
HP and hp	HP: High Pressure, hp: horsepower	NO or NC	Normally open or normally closed
SAE O-ring	O-ring threaded port style, SAE standard		

Fig #	Figure Title	Part Number	Page #
12-1	Waterjet Pump Assembly	80080641-480v, 80082365-208v	12-5
12-2	Intensifier Assembly	80079999	12-7
12-3	Seal Head Assembly	80072349	12-9
12-4	Hydraulic Piston	05132253	12-11
12-5	Hydraulic Cartridge	05130091	12-13
12-6	High Pressure Piping	80080153	12-15
12-7	Hydraulic Manifold Assembly	05129721	12-17
12-8	Bulkhead Piping	80080179	12-19
12-9	Low Pressure Water Filter Assembly	05126289	12-21
12-10	Motor/Pump Assembly	05125919	12-23
12-11	Reservoir Assembly	05126230	12-25
12-12	Electrical Assembly	05140140-480v, 05140801-208v	12-27
12-13	Control Panel Configuration	05140132-480v, 05140793-208v	12-29
12-14	Electrical Schematic	05140744-480v, 05141015-208v	
	Hydraulic Schematic	05129507	

Figure 12-1. WATERJET PUMP 80080641-480v, 80082365-208v

ITEM No.	QTY.	PART No.	DESCRIPTION
1	1	80080153	HP Water Assembly
2	1	05140140	Electrical Assembly
		05140801	
3	1	80080179	Bulkhead Pipe Assembly
4	1	05126248	Frame Assembly
5	1	05126230	Reservoir Assembly
6	1	05125919	Motor/Pump Assembly
7	1	05130042	Hydraulic Hose Connections
8	1	80080633	Decal Package
9	--	05072582	Stripping
10	--	05072590	Stripping
11	1	49838204	Decal-Lube Data
12	1	05128087	Start-up Tag
13	1	05135710	Test Report
14	--	05022702	Hydraulic Fluid
16	4	95688750	Lock Washer, .50
20	4	95367850	Lock Washer, .50

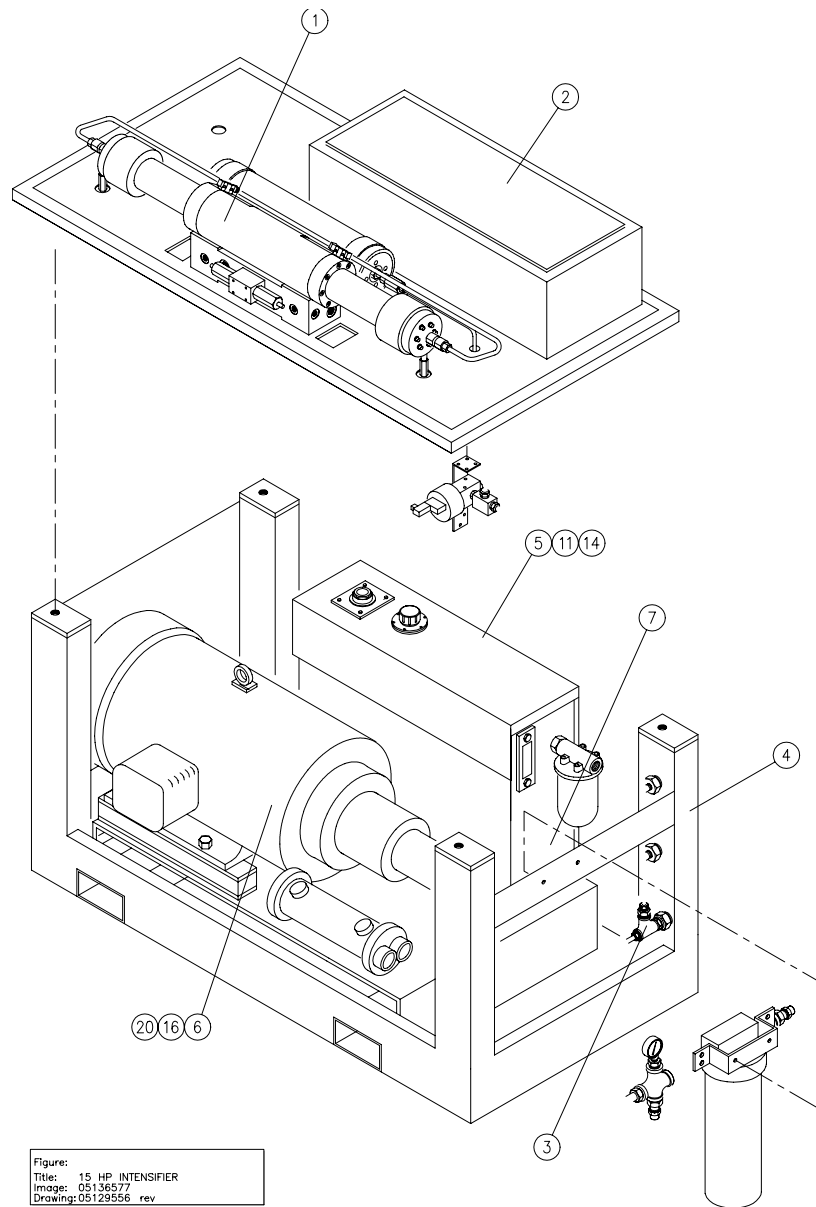

Figure:
Title: 15 HP INTENSIFIER
Images: 05136577
Drawing: 05129556 rev

Figure 12-2 HYDRAULIC INTENSIFIER ASSEMBLY 80079999

ITEM No.	QTY.	PART No.	DESCRIPTION
1	2	05144647	Body, Cylinder, HP, 1.13-in. ID
2	2	05119151	Plunger, Ceramic
3	2	80072349	Head Assembly, Sealing
4	2	05034772	Head, Cylinder
5	2	05149703	Seal Assembly
6	2	05144696	Seal Spacer
7	2	80073646	Nut, Retaining, Sealing Head
8	2	05130091	Seal Assembly, Plunger, Cartridge, Hydraulic
9	2	05007786	Flange, Retaining, Bushing
11	2	05144712	Liner, HP Cylinder
12	4	10074920	O-ring
13	12	80070352	Jackbolt
14	2	05034798	Ring, Retaining
15	1	05034764	Cylinder, Hydraulic
16	2	10075000	O-ring
17	2	05034855	Ring, Backup
18	16	05141106	Cap Screw, Socket Head, M14x60
19	2	05127584	Switch, Proximity, 20-250 VAC/VDC
20	4	10183572	Cap Screw, Socket Head, M6x1x22mm
21	1	05132253	Piston Assembly, Hydraulic
27	2	10074409	O-ring
28	2	05144183	Spacer, Proximity Switch
30	*	10148674	Special Tool, HP Seal Removal (Not Shown)
31	*	05066139	Special Tool, Wrench, HP Cylinder (Not Shown)
32	*	05004924	Special Tool, Plunger Removal

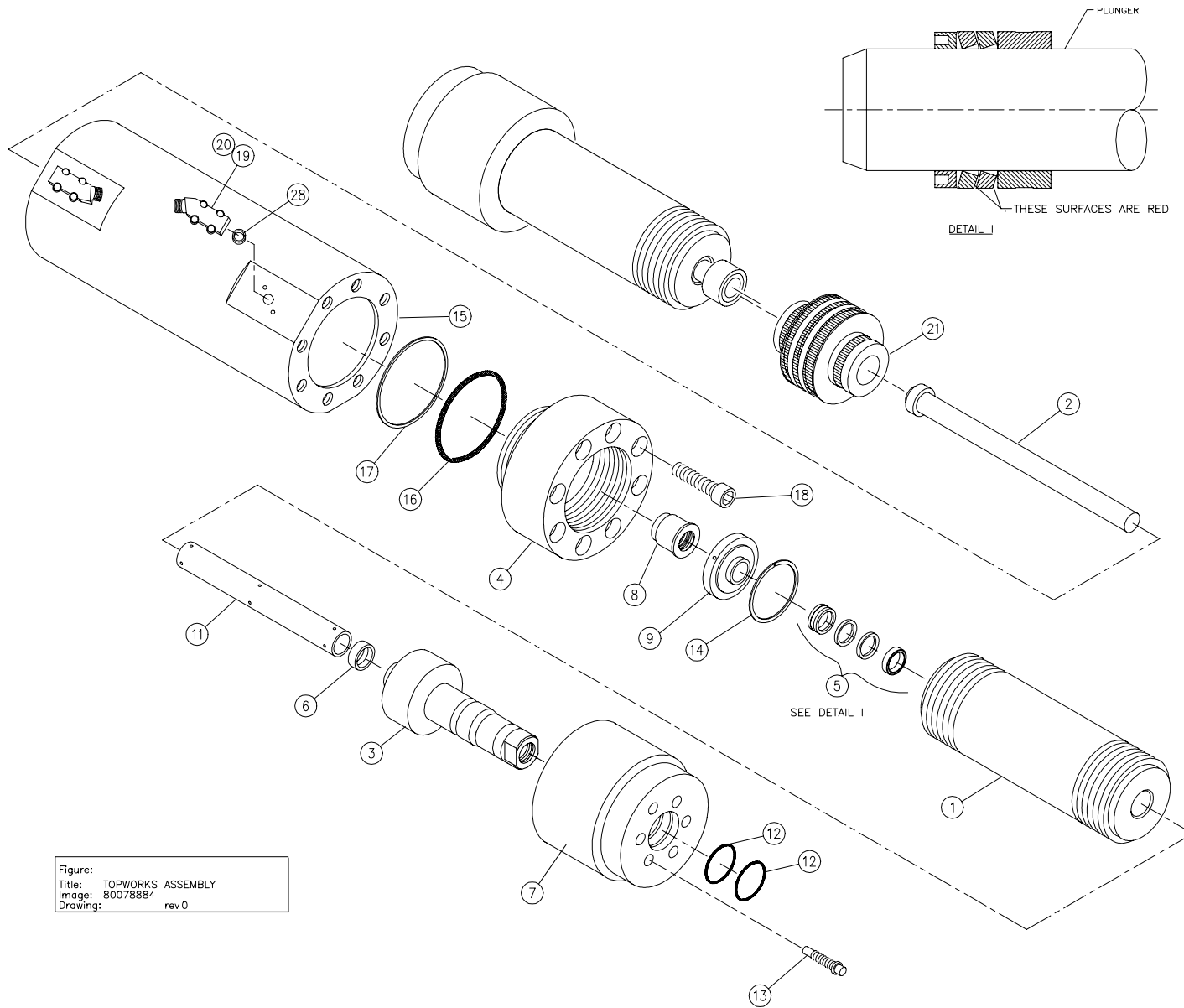

Figure:
 Title: TOPWORKS ASSEMBLY
 Image: 80078884
 Drawing: rev 0

Figure 12-3 SEALING HEAD ASSEMBLY 80072349

ITEM No.	QTY	PART No.	DESCRIPTION
1	1	49834039	Body, Sealing Head
2	1	05144662	Poppet, Inlet, Cutting Water
3	1	05116777	Gland, HP, Sealing Head
4	1	05112768	Seat, HP, Sealing Head
5	1	05116561	Poppet, Valve, HP Check
6	1	05144670	Retainer, Poppet
7	1	05147863	Spring, Compression
8	1	49884562	Spring, Compression
9	1	05116751	Pin, Guide

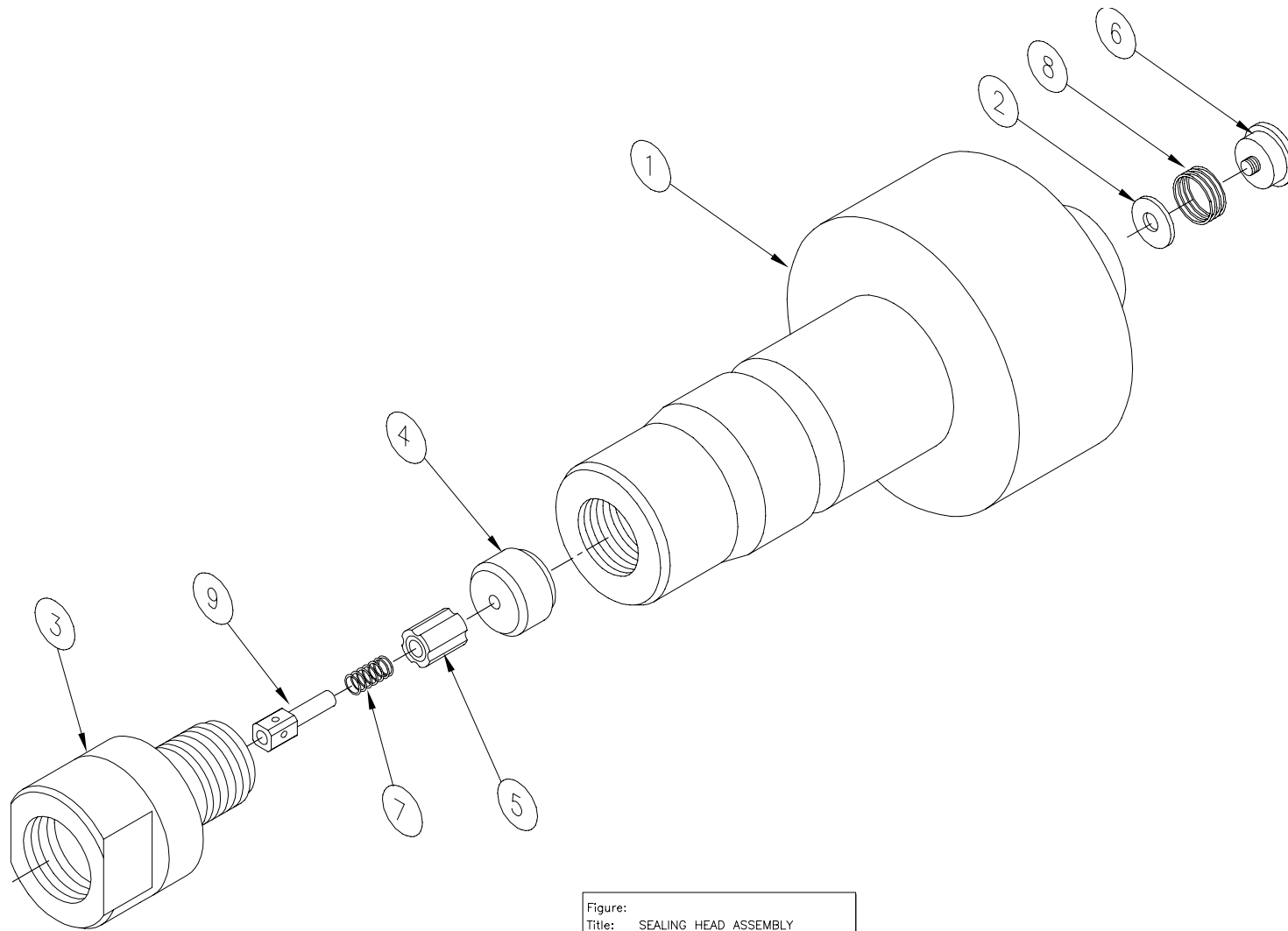

Figure:
Title: SEALING HEAD ASSEMBLY
Image: 80075153
Drawing: 80072349P rev 0

Figure 12-4 HYDRAULIC PISTON ASSEMBLY 05132253

ITEM No.	QTY	PART No.	DESCRIPTION
1	1	05132261	Body, Hydraulic Piston
2	12	05074380	Pin, Clevis
3	2	05049887	Screw, Set, Socket, with Through Hole
4	2	10148757	Valve, Check, Cartridge, with O-ring
5	--	49877509	Adhesive, Thread Locker
6	2	05088364	Ring, Snap, Flat Wire
7	2	05049994	Ring, Backup
8	2	05087713	O-ring
9	1	05117965	Seal Assembly, Hydraulic Piston
10	2	05117940	Bearing, Hydraulic Piston

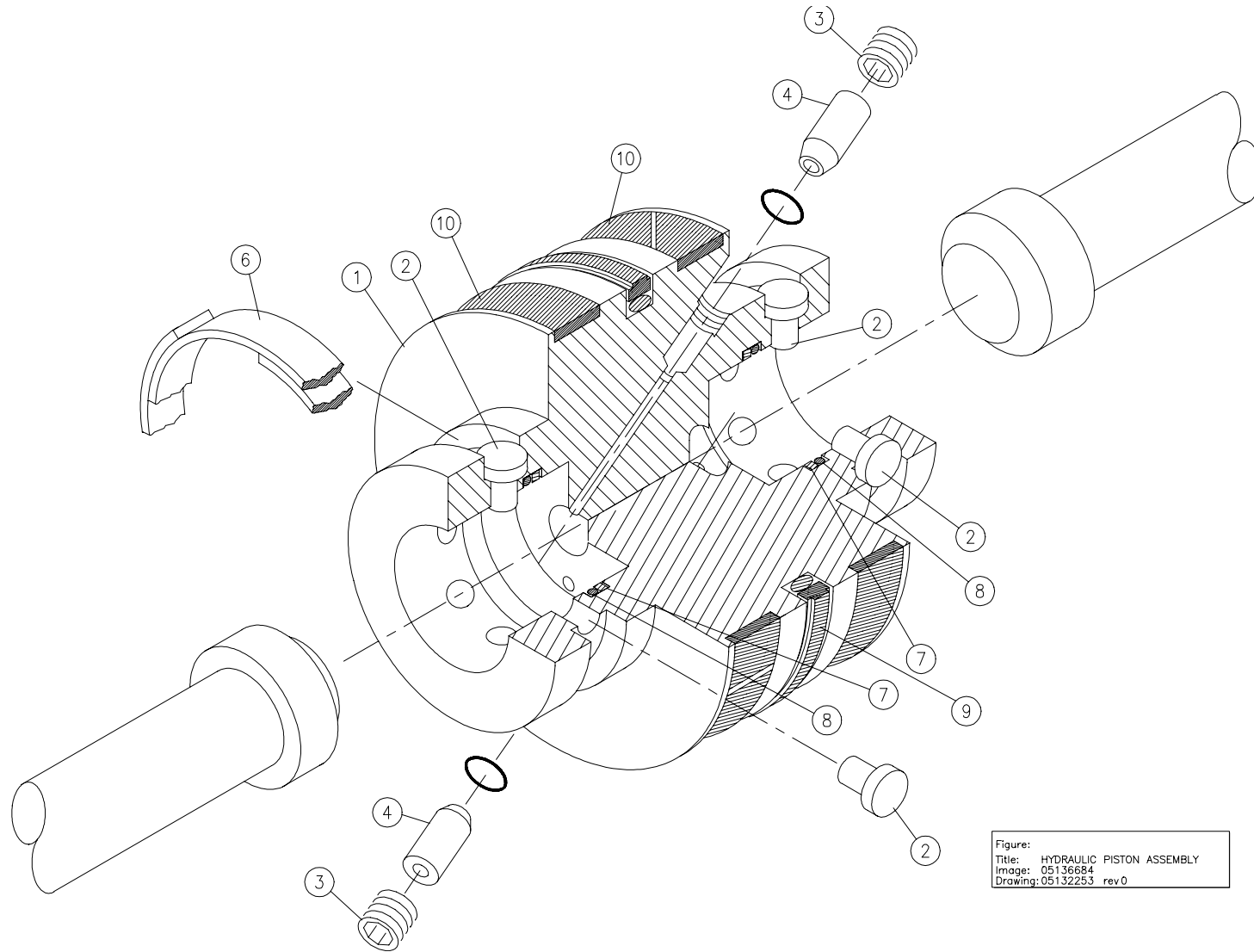

Figure:
Title: HYDRAULIC PISTON ASSEMBLY
Image: 05136884
Drawing: 05132253 rev 0

Figure 12-5 HYDRAULIC CARTRIDGE SEAL ASSEMBLY 05130091

ITEM No.	QTY	PART No.	DESCRIPTION
1	1	05130109	Body, Seal, Cartridge
2	2	05015060	Seal, U-Cup, with O-ring
3	1	10193522	O-ring
4	1	05050760	Ring, Backup
5	1	05129481	O-ring
6	1	05013024	O-ring
7	1	05129515	Back-up Ring
8	1	05027255	Seal, U-Cup
Ref 1	0	05009048	Tool, Seal Installation

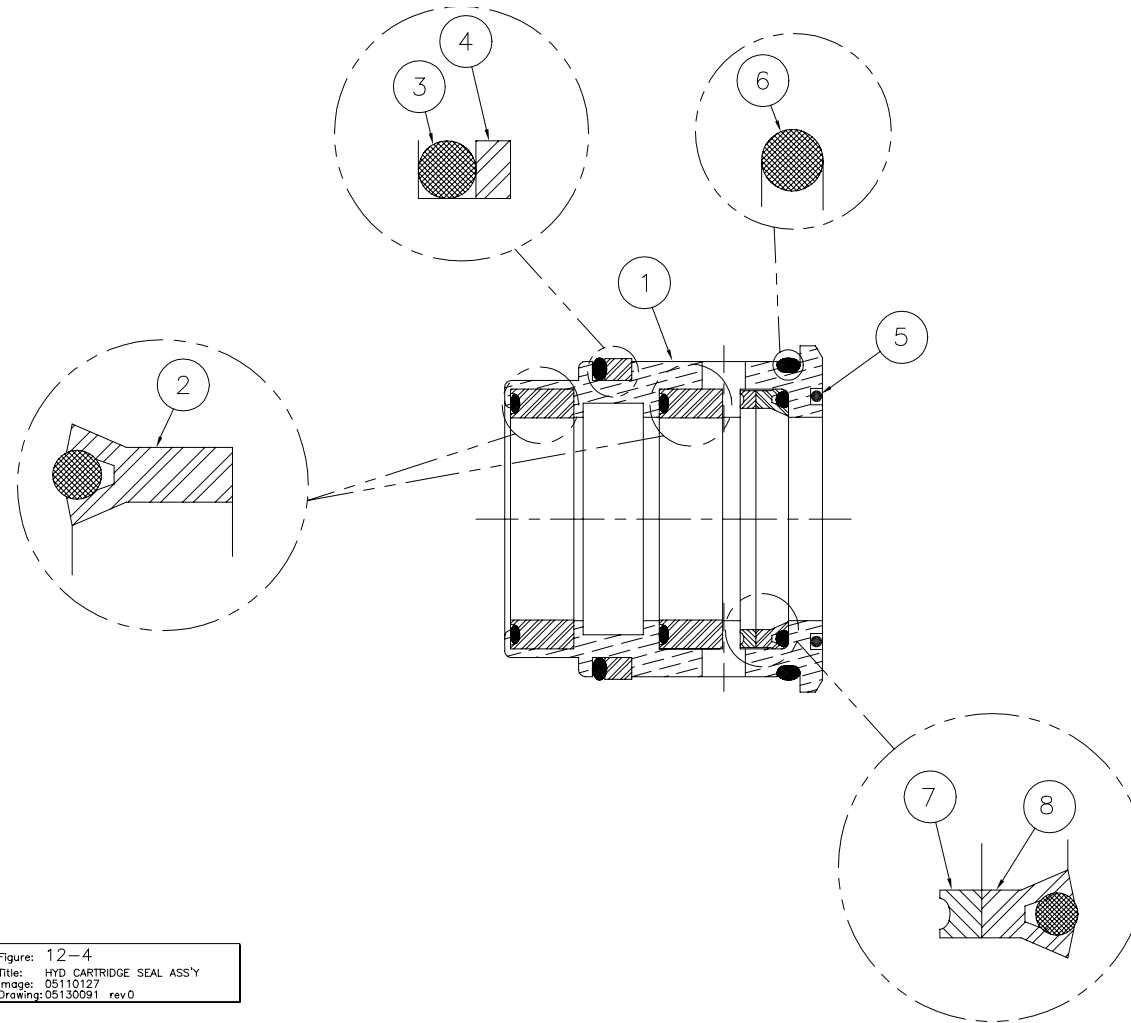

Figure: 12-4
Title: HYD CARTRIDGE SEAL ASS'Y
Image: 05110127
Drawing: 05130091 rev 0

FIGURE 12-6 HIGH PRESSURE WATER ASSEMBLY, 80080153

ITEM No	QTY	PART No.	DESCRIPTION
1	1	05127519	Tube, Bent, .38-in. HP, 60 ksi, Stainless
2	1	05127501	Tube, Bent, .38-in. HP, 60 ksi, Stainless
3	2	10078590	Tee, .38-in. HP Tube, 60 ksi, Stainless
4	2	10079531	Reducer Coupling, .38 x .56, 60 ksi, Stainless
5	1	05127972	Tube, Bent, .38-in. HP, 60 ksi, Stainless
6	2	10078129	Gland, .38-in. HP Tube, 60 ksi, Stainless
7	2	10078715	Collar, .38-in. HP Tube, 60 ksi, Stainless
8	1	80079999	Intensifier Assembly
9	1	05127659	HP Attenuator
10	10	10083897	Ferrule, .25, Brass
11	1	05129721	Manifold Assembly
12	100"	10186153	Conduit, Extra Flexible, .38-in. ID
13	2	05131107	Manifold Gasket
14	4	05092903	Attenuator Bracket Spacer
15	4	95413696	Lock Washer, .50
16	4	95383790	Socket Head Screw, 1/2-13 x 1.00
17	1	05129374	Tube, Bent, .38-in. HP, 60 ksi, Stainless
18	1	05129390	Tube-HP, .25 x 35.00
19	1	05069703	Pneumatic Valve Assembly
20	1	10094704	Tube-HP, .25 x 3.00
21	1	10078160	Bulkhead Coupling, .38
22	1	05129366	Tube, Bent, .38-in. HP, 60 ksi, Stainless
23	2	95896379	Socket Head Screw, 1/4-28 x 3/4
24	2	95838314	Lock Washer, .25
25	2	95391322	Washer, .25
26	8	05050323	Socket Head Screw, M10 x 1.50 x 90mm
27	8	05061486	Lock Washer, M10
28	2	10074409	O-ring

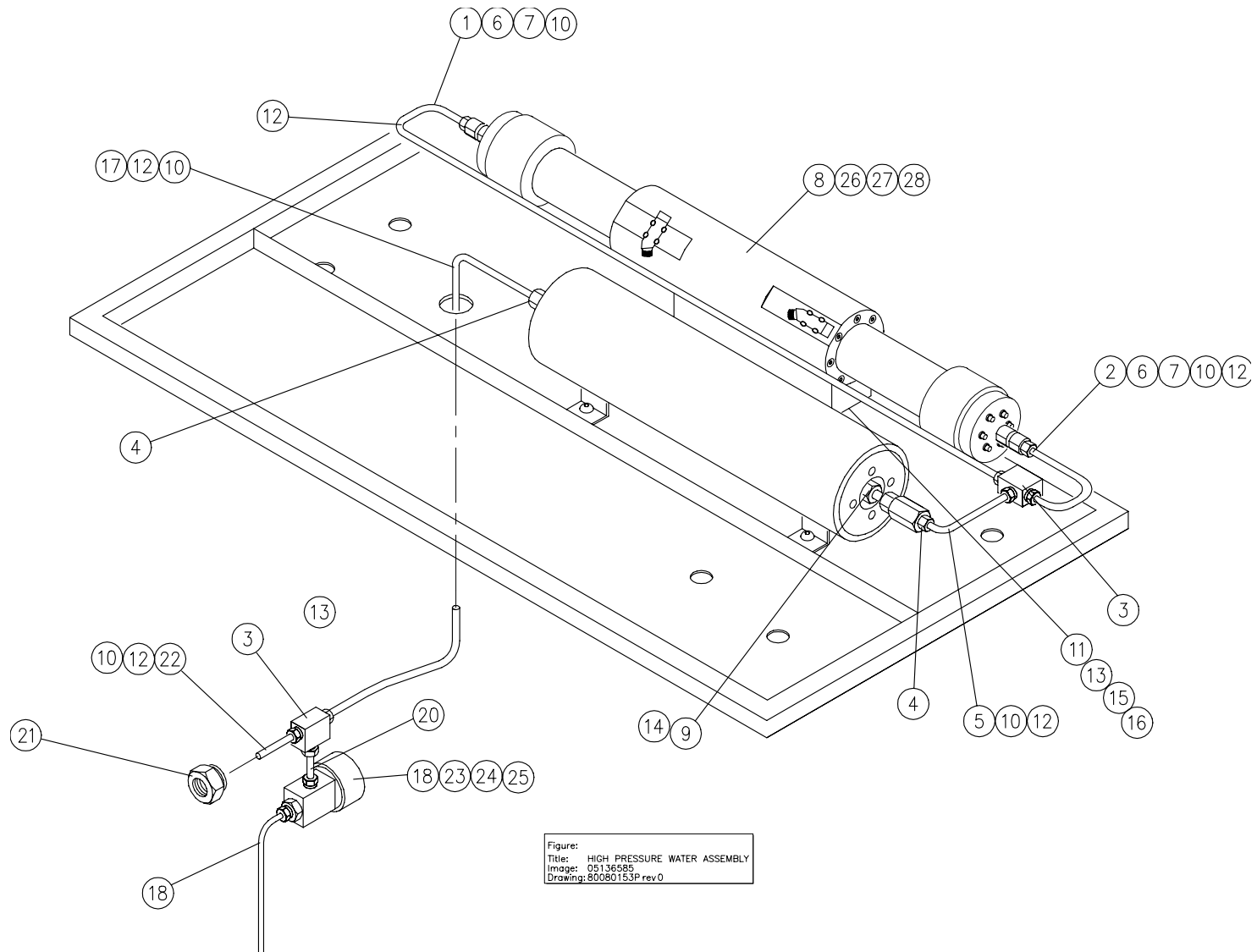

Figure:
 Title: HIGH PRESSURE WATER ASSEMBLY
 Image: 05136585
 Drawing: 80080153P rev.0

Figure 12-7 HYDRAULIC MANIFOLD ASSEMBLY, 05129721

ITEM No.	QTY	PART No.	DESCRIPTION
1	1	05129549	Block, Manifold, Hyd
2	1	10114908	Valve, Pressure Unloading, Startup
3	1	05071717	Valve, Relief, Hyd, 234 bar (3,400 psi)
4	7	05104559	Plug, -6 SAE O-ring Port
5	1	10192813	Plug, -4 SAE O-ring Port
6	1	05057567	Adapter, -12 SAE O-ring x -8 JIC
7	1	10144749	Adapter, -4 JIC x -4 SAE O-ring, Straight
8	1	10087880	Adapter, -8 SAE O-ring x -8 JIC
9	4	10110567	Cap Screw, Socket Head
10	4	95367728	Washer
11	1	05129069	Valve, Directional Control, Air-Operated
12	2	10078095	Coupling, Male, .25 .125

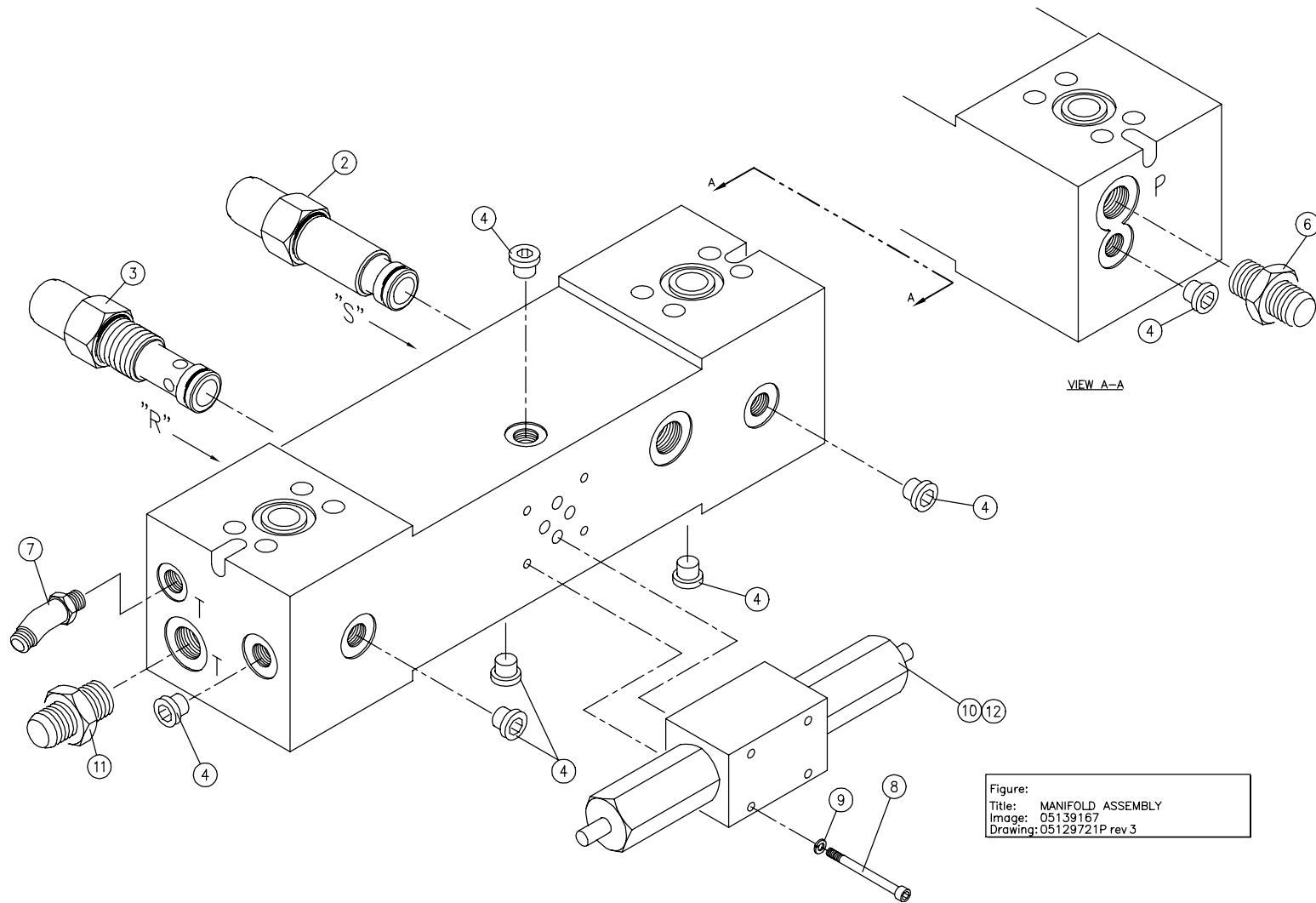

Figure:
 Title: MANIFOLD ASSEMBLY
 Image: 05139167
 Drawing: 05129721P rev 3

Figure 12-8 BULKHEAD PIPING ASSEMBLY, 80080179

ITEM No	QTY	PART No.	DESCRIPTION
1	1	10091866	Valve, Modulating
2	4	10078194	Bulkhead Adapter, ½-1-1/2 NPT
3	-	10127348	Hose, Push-On, .50-in. ID
4	1	10073823	Tee, Male Run, ½-NPT, Brass
5	1	05126289	Filter Assembly, LP Water
6	1	49834328	Adapter, .25 OD Tube x ½ - NPT
7	1	10077055	Adapter, Bulkhead, 4-15
8	1	10189900	Tee, Male Run, ¼ x 1/8 NPT,
9	-	10079903	Tube, Polyethylene, .25-in. OD
10	1	10145829	Nipple, Close, ½-NPT, Brass
11	2	49834302	Adapter, Tube/Pipe, .50
12	2	05128947	Adapter, 1/4 NPT x -8 JIC,
13	5	10079713	Barb, .50, NPT
14	3	10173805	Barb, Hose, 0.50 x -8JIC
15	5	05113964	Grommet
16	1	10147460	Elbow, ½-NPT x -8 JIC, 90 degree
17	1	10100477	Bushing, ¼ x1/8 NPT, Brass
18	1	05128715	Valve, Solenoid, 24vdc
19	1	05112271	Muffler, Pneumatic, 1/8-NPT
20	2	05143508	Screw, Machine, #4-40 x 1-1/2
21	2	10118214	Lockwasher #5-40
22	2	10078095	Coupling, Poly, ¼ x 1/8 NPT
23	1	10077030	Elbow, 90-deg, M, .25 x .13
24	2	95146403	Hex Nut, #4-40
25	1	49834310	Adapter, Tube/Pipe, .50
26	3	49831480	Grommet

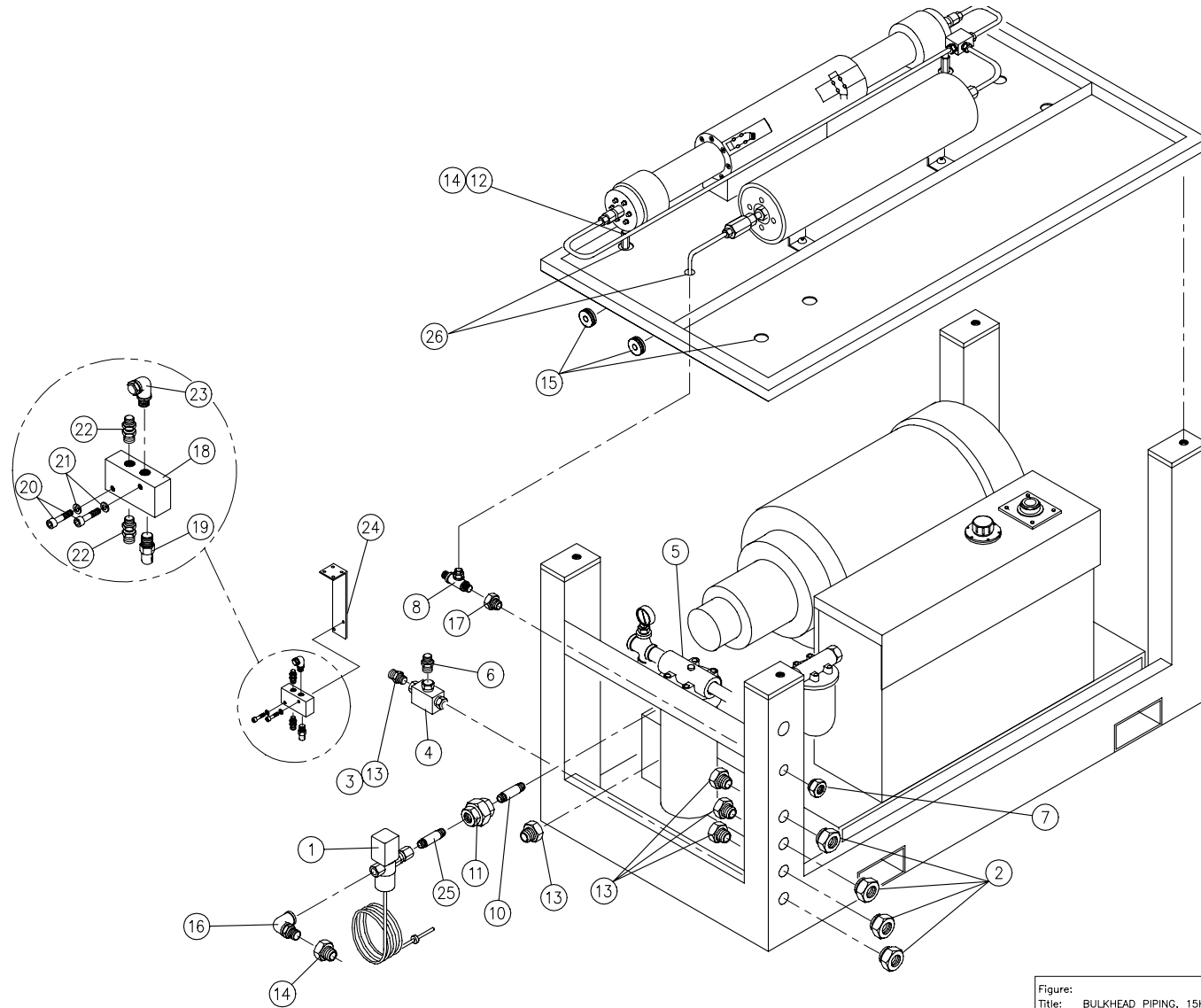

Figure:
 Title: BULKHEAD PIPING, 15HP
 Image: 05136593
 Drawing: 80080179P Rev 0

Figure 12-9 LOW PRESSURE WATER FILTER ASSEMBLY, 05126289

ITEM No.	QTY.	PART No.	DESCRIPTION
1	1	05016381	Filter Body, with Air Bleed- off Valve
2	1	05127212	Valve, Relief, 50 – 150 psi
3	1	05105440	Gage, Pressure, 0–100 psi, ¼" NPT, Bottom-Mount
4	2	10078152	Adapter, Bushing, ¾ x ½" - NPT, Brass
5	1	10078343	Adapter, Bushing, ½ x ¼" - NPT, Brass
6	2	10127801	Nipple, ½ NPT x 2.50-in., Brass
8	1	49870272	Cross, ½ - NPT, Brass
10	1	10073823	Tee, ½-NPT, Brass
11	2	05123666	Adapter, ½" NPT x –8 JIC, Straight, Brass
12	4	10173805	Barb, ½" ID Hose, -8 JIC Swivel, Brass
13	2	10114023	U-Bolt, 0.50, Stainless
14	1	10106722	Element, Filter, LP Water, Polypropylene, 10 Micron
15	1	10147460	Elbow, ½-NPT x –8JIC, Brass
16	1	95157418	Adapter, ½-NPT x –8JIC, Straight, Brass
17	1	05016514	Elbow, 90 deg, ½-NPT x –8JIC

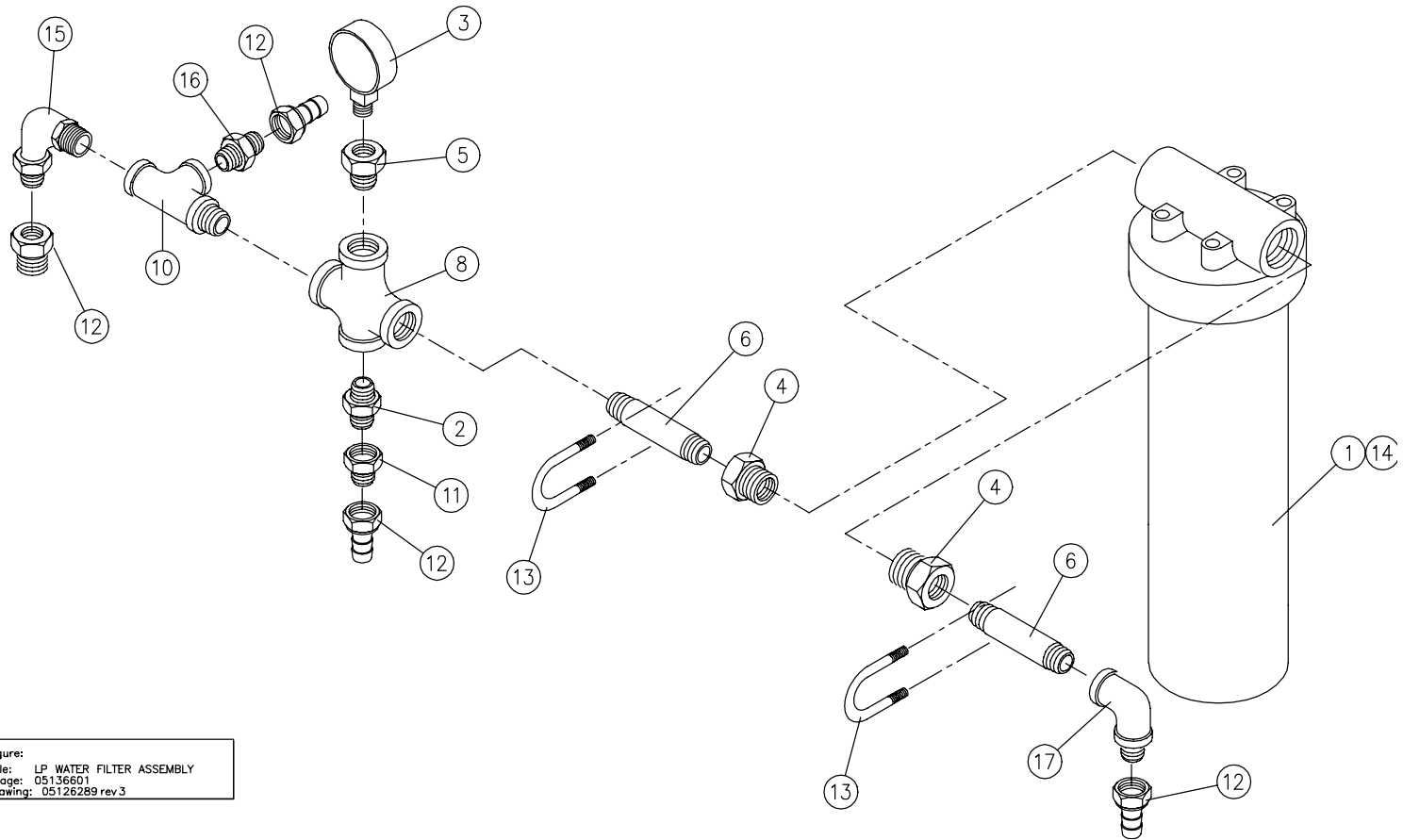

Figure:
 Title: LP WATER FILTER ASSEMBLY
 Image: 05136601
 Drawing: 05126289 rev 3

Figure 12-10 MOTOR / PUMP ASSEMBLY, 05125919

ITEM No.	QTY	PART No.	ITEM DESCRIPTION
1	2	05144027	Mount, Vibration Isolation, Motor Base
2	4	10170686	Washer, Lock, ½-in. ID, Stainless
3	4	10066199	Cap Screw, Hex Head, 1/2-13 x ¾, SST
4	1	05125927	Motor, Electric, 15hp, SAE-C Face, 200/400/230/460/3ph/50-60 Hz
5	2	95738514	Cap Screw, Hex Head, 1/2-13 x 1
6	--	10184802	Grease, Anti-Seize, "Optimal"
7	1	05125935	Piston Pump, Hyd, 28cc/Rev, Thru Shaft, 3000 psi
8	2	10069714	Washer, Flat, .38-in. ID
9	2	05037593	Cap Screw, Socket Head, M10 x 1.50 x 25mm, SST
10	1	05126008	Pump, Gear, Hyd, 22cc/Rev
11	1	05126339	Elbow, Hyd, -20/4-Bolt Flange x -20 Hose Barb
13	1	05045497	Pressure Gage, Hyd, 0-5,000 psi, -4 SAE O-ring
14	2	05089867	Adapter, Hyd, -8 JIC x -12 SAE O-ring, Straight
16	1	05127402	Adapter, Hyd, -8 JIC x -8 SAE O-ring, 90 Degree
17	1	49881774	Adapter, Hyd, -12 JIC x -12 SAE O-ring, 45 Degree
18	1	10119337	Split Flange Kit, Hyd, -20-4 Bolt Flange w/O-ring, Cap Screws
20	4	05041058	Cap Screw, Socket Head, 3/8-16 x 2.25"
21	4	95688743	Washer, Lock, High Collar, 0.38 ID
22	1	10074409	O-ring
23	1	05130935	Check Valve Cartridge
24	1	05130885	Check Valve Hydraulic Manifold

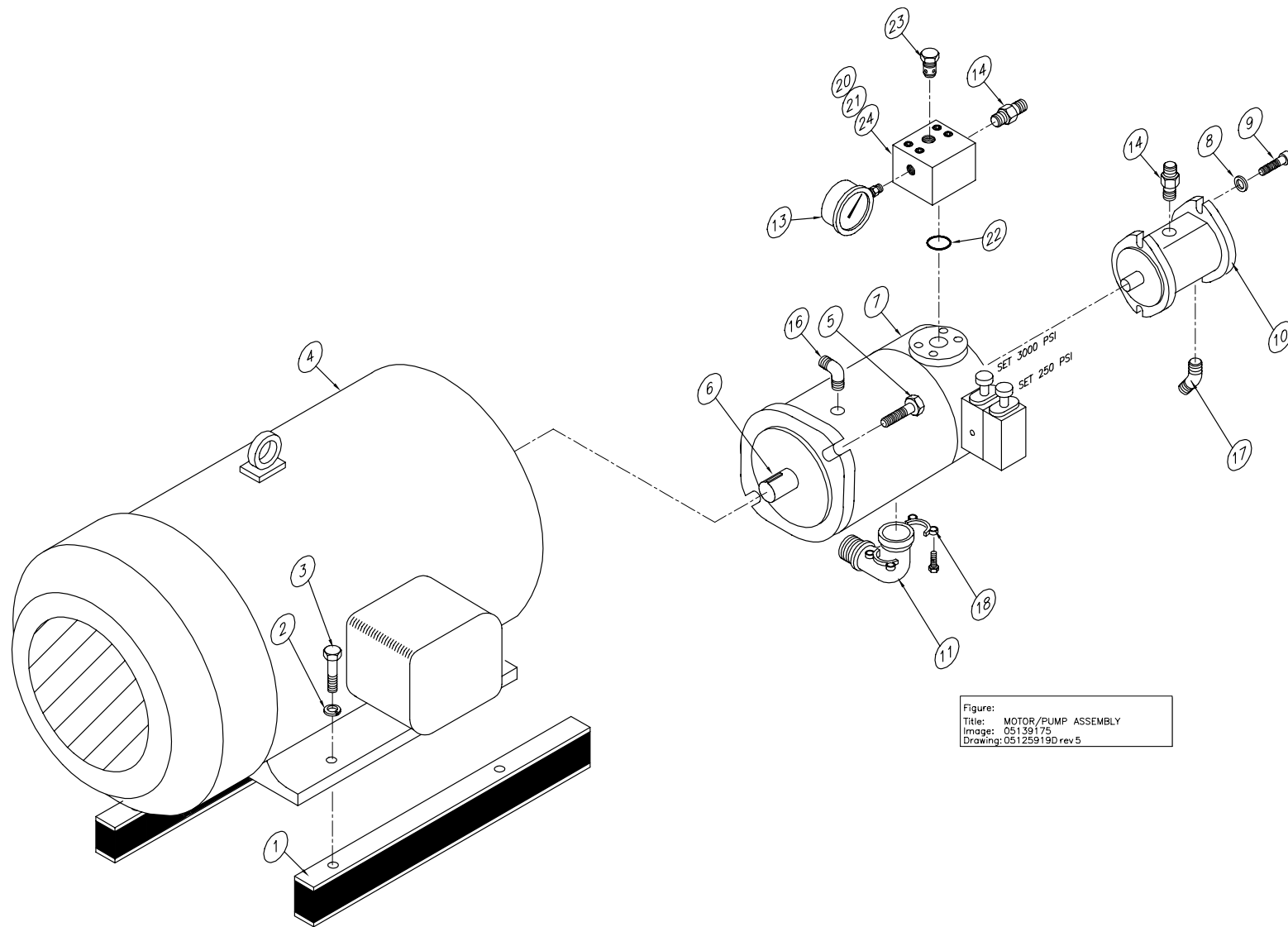

Figure 12-11 HYDRAULIC RESERVOIR ASSEMBLY, 05126230

ITEM No	QTY	PART No.	DESCRIPTION
2	1	05050026	Switch, Temperature / Level, Hyd, Cartridge- Type, 149 deg F
3	1	05092739	Breather, Air, 40 Micron, 3/8" NPT
4	1	10168862	Gage, Dual Scale, Level/Temperature, Oil
5	1	05049697	Housing, Filter, Hyd Oil, w/Gage, 50psi Bypass Valve, -12 SAE O-ring
6	1	05049689	Element, Filter, Hyd Oil, Spin-on Type, 6 – Micron Absolute
7	1	05130968	Tee-Male Branch, Pipe/JIC, 12-12
8	1	05069976	Cap, 3/4 NPT Hex, Steel
9	1	05047451	Adapter-JIC/O-ring, 90 degree, 12-12
10	1	05129424	Oil Cooler, Hyd
11	1	10091858	Bulb Well, 3/4" NPT
12	1	05057559	Adapter, -12 SAE O-ring x 3/4" NPT, Straight, Steel
13	3	10099901	Elbow-1/4" NPT x -4 JIC, 90 Degree, Steel
14	1	10080901	Ball Valve, 1/2" NPT, Bronze
15	1	95033619	Plug-Square Head, 1/2" NPT, Steel
16	1	05079371	Adapter, 12 JIC x -12 BSPP, Straight, Steel
17	1	10057719	Adapter, 3/4" NPT x -8 JIC, 90 Degree, Steel
18	4	95416319	Hex Head Screw, 3/8-16 x 1
19	4	10069714	Washer, 0.38
20	4	95750394	Lock Washer, 0.38
21	1	49879513	Elbow-Pipe/JIC, 90 degree, 12-12
22	1	05060777	Adapter, JIC,45 degree, Male/Female, 12-12
Ref 1	0	05126941	Reservoir Weldment
Ref 2	0	05127949	Reservoir Lid
Ref 3	0	05127071	Reservoir Support Weldment
Ref 4	0	05128160	Gasket, Cover, Reservoir

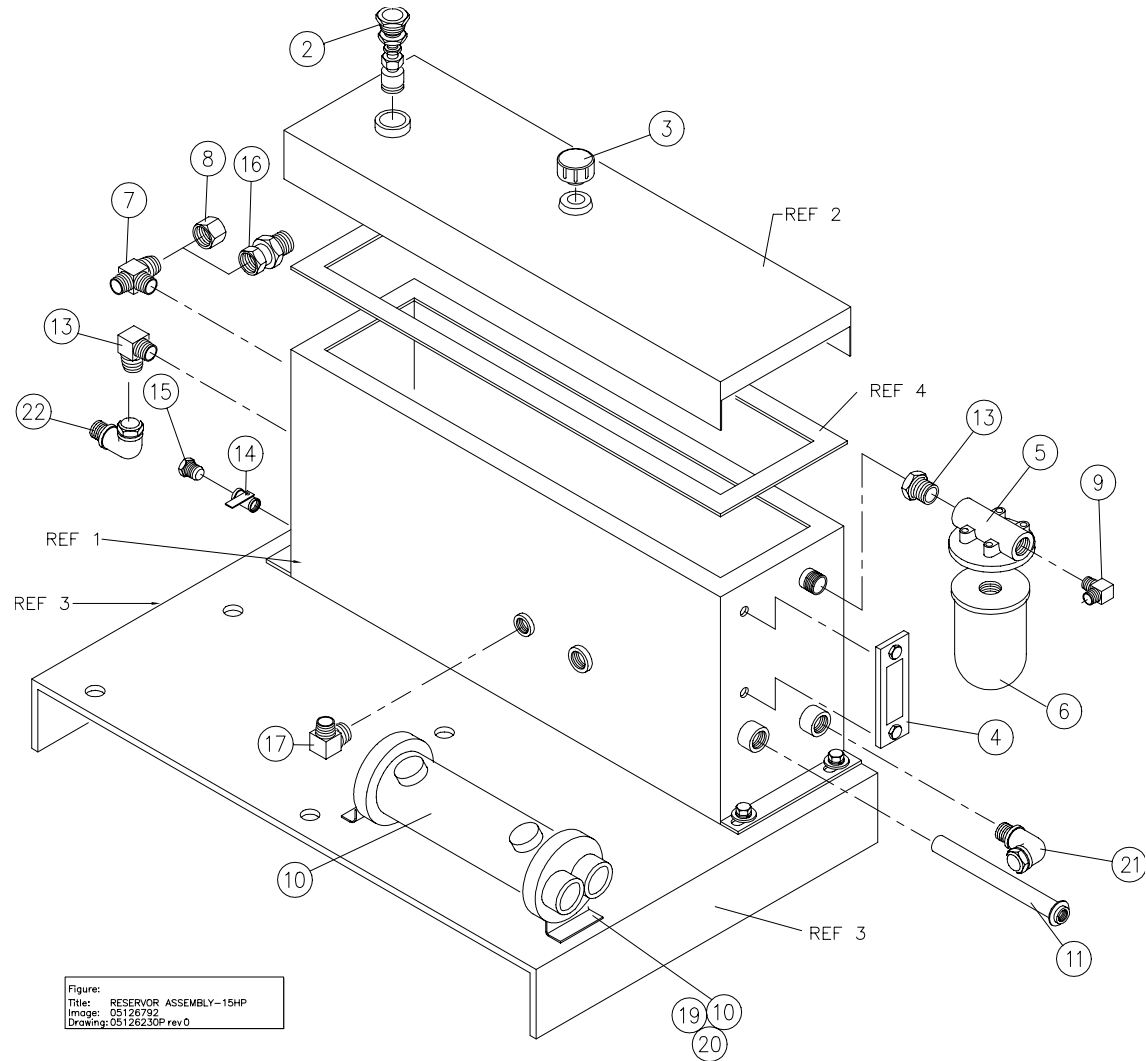

Figure:
 Title: RESERVOIR ASSEMBLY-15HP
 Image: 05128702
 Drawing: 05128230P rev 0

Figure 12-12 ELECTRICAL ASSEMBLY, 05140140-460v, 05140801-208v

ITEM No.	QTY.	PART No.	DESCRIPTION
1	7	05133863 05141692	Crimp Connector #8
2	2	05133707	Conduit Bushing
3	1	10196723	Conduit Connector
4	50"	10098770	Flexible Conduit
5	-	10094043 49877152	Wire, Black
6	72"	05127329 05141734	Wire, Green/Yellow
7	1	10098796	Conduit Connector
8	1	98423653	Hex Head Screw, 1/4-20 x 1/2
9	2	10157659	Lock Washer, .25
10	1	95416335	Hex Nut, 1/4-20
12	7	05133715 05141700	Ring Terminal
13	12	10094712	Ring Terminal
14	5	10125912	Cable Tie
15	1	05140132 05140793	Control Panel
16	4	10086650	Washer, 1.25
17	4	95416319	Hex Head Screw, 3/8-16 x 1.00
18	4	10069714	Washer, .38

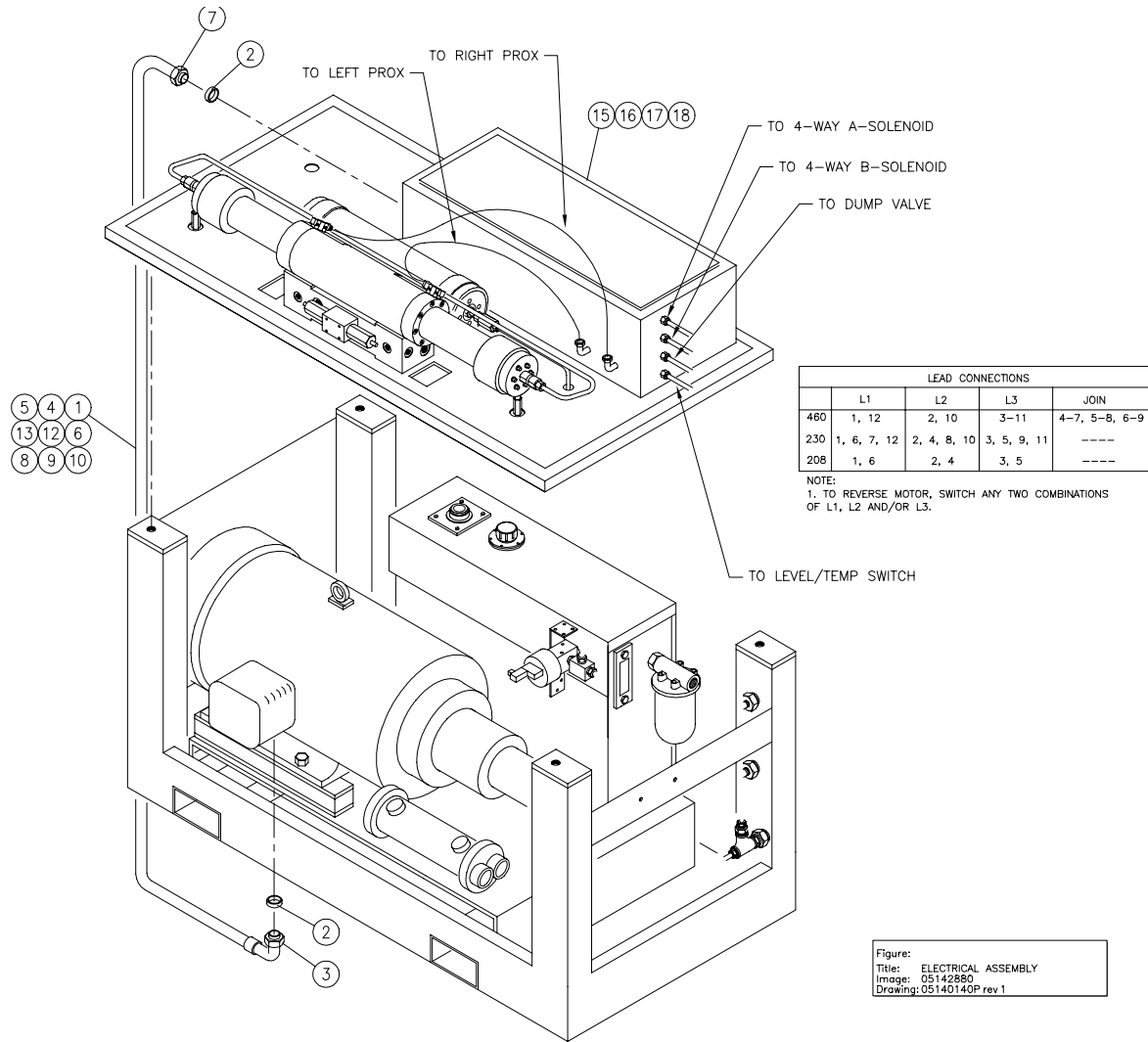

Figure:
Title: ELECTRICAL ASSEMBLY
Image: 05142860
Drawing: 05140140P rev 1

Figure 12-13 CONTROL PANEL CONFIGURATION, 05140132-480v, 05140793-208v

ITEM No.	QTY	PART No.	DESCRIPTION
1	1	05140736	Motor Protector
2	4	10073500	Screw, Pan Head, #8-32 x 3/4
3	1	05140728	Handle, Open
4	1	05140991	Extension Shaft, Manual
5	72"	10098275	Wire, Black
		49878754	
6	1	05127360	Power Supply
		05140876	
7	2	49873110	Screw, Rnd Hd, 1/4-20 x 3/4
8	10	10073492	Screw, Pan Head, #8-32 x 1/2
9	2	05117627	Contactor, Non-rev
		05111455	
10	26	05140702	Crimp Connector
		05141007	
13	2	05141650	Ground Lug
14	48"	05019898	#14 Wire, Black
15	1	05140686	Circuit Breaker, 600V
16	27"	10103034	Din Rail
17	14	05019617	Crimp Connector, #14
		10170157	
18	18"	10170140	Wire, Green/Yellow
19	30"	05127329	#12 Wire, Green/Yellow
24	4	05032362	End Anchor
25	100"	10185395	Crimp Connector, #16
26	7	05032420	Terminal Block , #24-#12
27	1	05115134	End Barrier
		28	1 10094712 Ring Terminal
		29	720" 10176410 Wire, #16, Blue
		30	24" 10170165 Wire, #16, Green/Yellow
		31	1 05140678 Circuit Breaker, 3-amp
		32	1 05140660 Switch, Emergency Stop
		33	1 05140652 Block, Contactor, 1-NC
		34	1 05005202 Legend Plate
		35	28 05032438 Terminal Block
		36	1 05032370 End Barrier
		37	1.6 05032388 Terminal Block Jumper
		38	.56 05032412 Terminal Block Marker
		39	3 10186104 Relay, Tube Base, 24 VDC
		40	3 10196012 Base Relay, 11-Pin, Octal
		41	1 10170504 Switch, Pushbutton, White
		42	3 05140645 Block, Lamp Socket, 24V Bulb
		43	3 05140637 Block, Contact, 1-NO
		44	4 05140629 Legend Plate Holder
		45	2 05140611 Legend Plate-Power On
		46	3 10152007 Pilot Light
		47	1 10149110 Switch, Pushbutton, Green
		48	2 95146411 Hex Nut, #6
		49	1 05140603 Switch, Pushbutton, Red
		50	1 05127261 Legend Plate-Stop
		51	1 10157659 Lock Washer, .25
		52	.63 05028527 Wiring Duct
		53	14 10170132 Rivet
		54	1 05127253 Enclosure, Electrical
		55	1 05127246 Panel Insert, 9 x 27-inches
		56	1 05140595 Block, Contactor, 1-NC
		57	1 05140587 Switch, Selector, Keyed

58	1	05114889	Legend Plate-Remote Control	71	1	05140553	Auxiliary Contact
59	2	95416335	Hex Nut, 1/4-20	72	1	05140546	Timer Module, Pneumatic
60	12"	10102242	Spiral Wrap	73	4	10067205	Cable Connector
61	1	10189355	Hourmeter, Rectangular	74	6	10083012	Lock Nut- Conduit, .50
62	2	49885650	Disconnect, Female	75	6	10082857	Gasket Assembly
63	1	05000724	Gasket	76	140"	10108470	#18 Cable
64	2	10076206	Screw, Flat Head, #6-32 x 1/2	77	2	10084184	Plug Connector
65	2	95750451	Lock Washer, #6	78	1	05066576	Plug Connector
66	2	05129705	Surge Suppressor	79	2	10124287	Cable Connector
67	.4	05032347	Terminal Block Jumper	80	18	10170371	Crimp Connector
68	1	05140579	Mounting Adapter	81	1	05111448	Overload Relay
69	2	05140561	Block, Contactor, 2-NC	82	1	05141601	Din Rail
70	1	05114962	Decal				

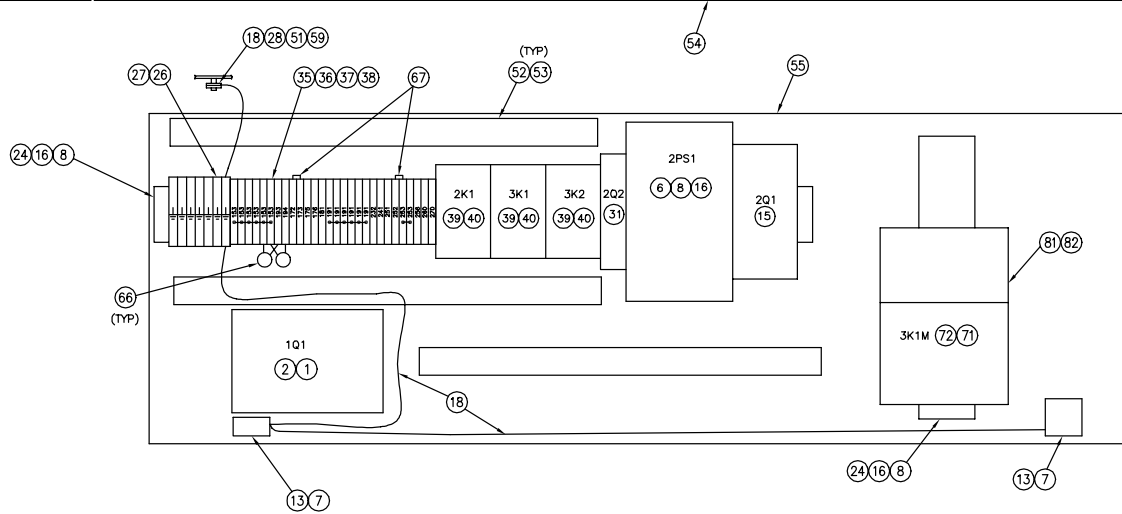
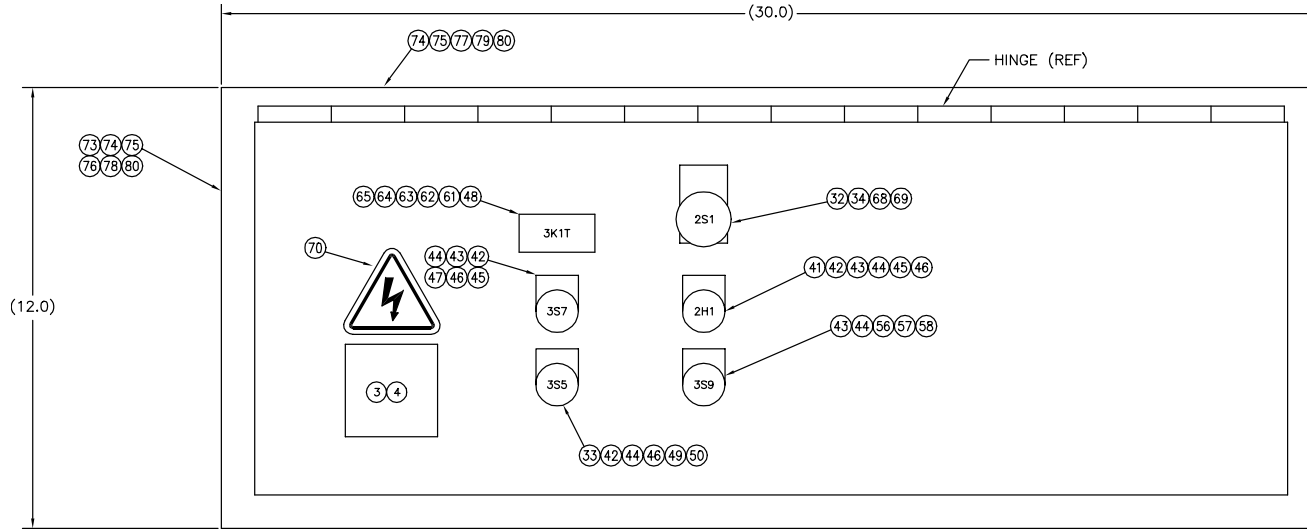
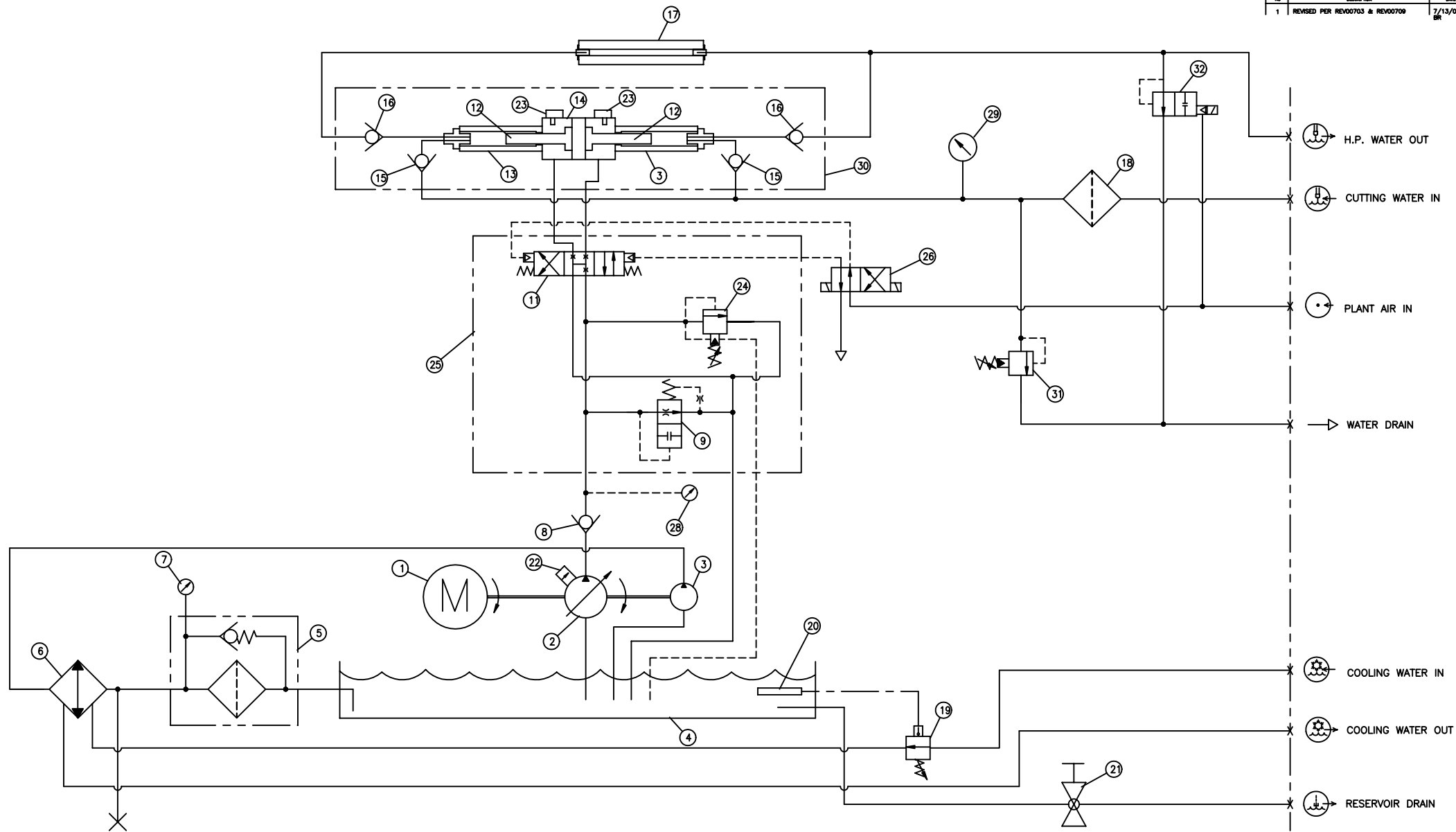
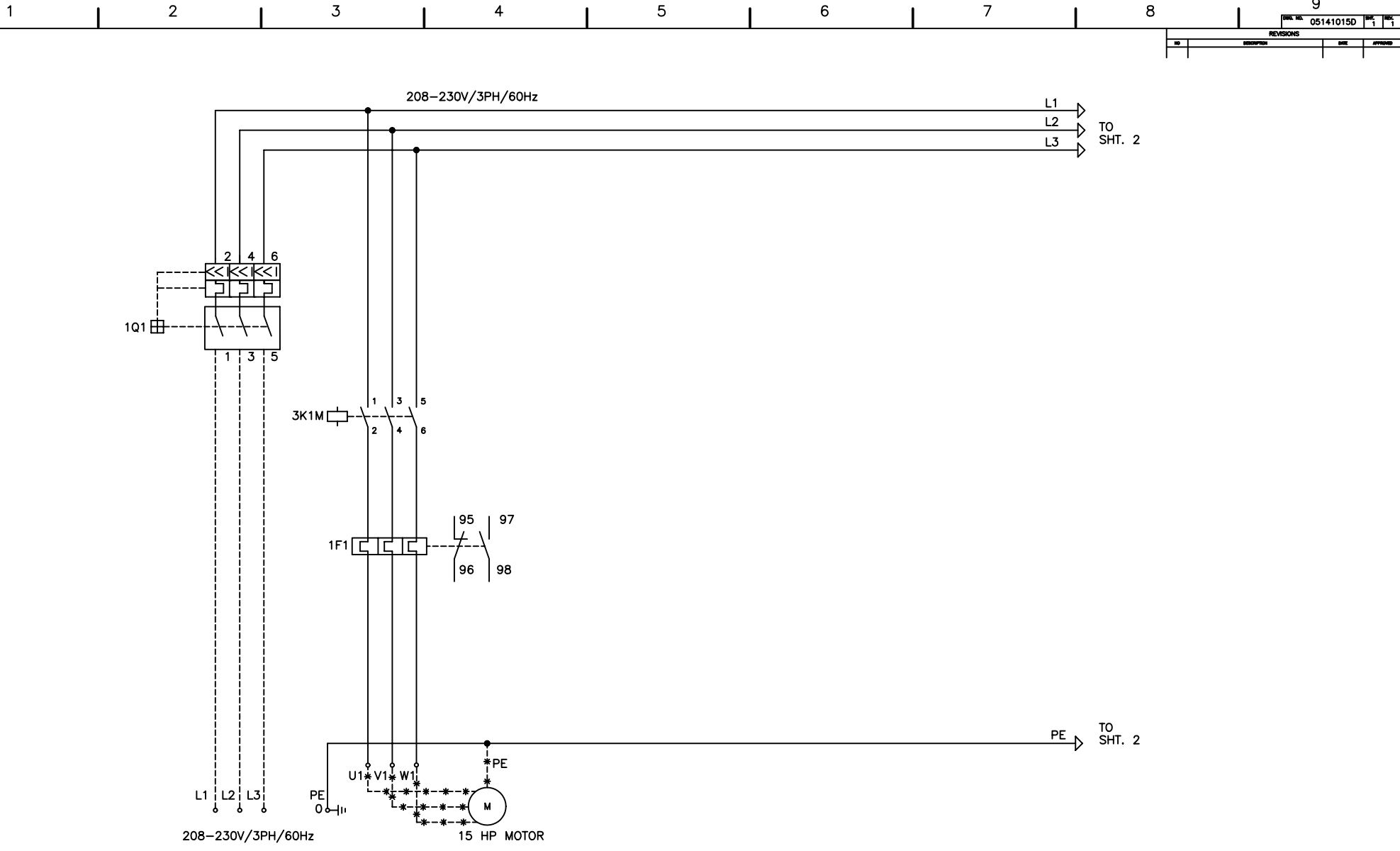

Figure:
Title: CONFIGURATION PANEL-15 HP
Image: 05142899
Drawing: 05140132D rev 0

REVISIONS			
NO	DESCRIPTION	DATE	APPROVED
1	REVISED PER REV00703 & REV00709	7/13/00 DK	7/13/00 LHJH S



Copyright © 1998 Ingersoll-Rand Company All Rights Reserved WARNING 1 The export or reexport of this drawing or a product produced by this drawing is subject to U.S. Export Administration regulations and other applicable governmental restrictions or regulations.	DIMENSIONS IN [] ARE MILLIMETRES	REF. GEOMETRIC SYMBOLS STRAIGHTNESS CIRCULARITY (ROUNDNESS) CYLINDRICITY FLATNESS PERPENDICULARITY PARALLELISM CONCENTRICITY TILT POSITION CIRCULAR RUNOUT TOTAL RUNOUT	UNLESS OTHERWISE NOTED, BREAK SHOWN EDGES & CORNERS .015 & SURFACE FINISH ALL OVER STANDARD TOLERANCES FRACTION DECIMAL SURF A. HUND. 1/50 TENS. HUND. 1/50 APPROX. 1/50 X.X = ±.063 X.XX = ±.015 X.XXX = ±.005 ANGLE = ±0°30'	INGERSOLL-RAND WATERJET SYSTEMS HYDRAULIC SCHEMATIC 15HP SLIV DWG. NO. 05129507D SHEET 1 OF 1
	NEXT ASSEMBLY	REF.	TOLERANCES	TOLERANCES



REVISIONS			
NO	DESCRIPTION	DATE	APPROVED
1			

NOTE: ----- WIRING BY CUSTOMER IN ACCORDANCE WITH LOCAL REGULATIONS.
 --* WIRING BY I-R EXTERNAL TO PANEL

Copyright © 2001 Ingersoll-Rand Company All Rights Reserved	PROPRIETARY NOTICE This document contains confidential and trade secret information, is the property of Ingersoll-Rand Co., and is given to the receiver in confidence. The receiver by receipt and retention of this document accepts the document in confidence and agrees that, except as authorized in writing by Ingersoll-Rand Co., it will (1) not use the document or any copy thereof or the confidential or the trade secret information thereof; (2) not copy the document; (3) not disclose to others either the document or the confidential or trade secret information therein; and (4) upon completion of the need to retain the document, or upon demand, return the document, all copies thereof, and all material copied therefrom.	STANDARD TOLERANCES UNLESS OTHERWISE NOTED: ALL DIMENSIONS ON COMMON CENTERLINE CONVAL TO A05 BROWN SHARP EDGES AND CORNERS 010 SURFACE FINISH - ✓ -STAMPED TOLERANCES X.X = ±.003 X.XX = ±.015 X.XXX = ±.005 ANGLE = ±2°	GD&T TO ASME Y14.5M 1994	REV. 001 05127121D DRAWN BY A SIE B RUMBEL 2/01 CHECKED BY A SIE M MANN 2/01 DATE APPROVED & DATE	Ingersoll-Rand
WARNING ! The export or reexport of this drawing or a product produced by this drawing is subject to U.S. Export Administration regulations and other applicable governmental restrictions or regulations.					ELECTRICAL SCHEMATIC 15HP,SL4, 208-230/3/60 DWG. NO. 05141015D SHEET 1 OF 3

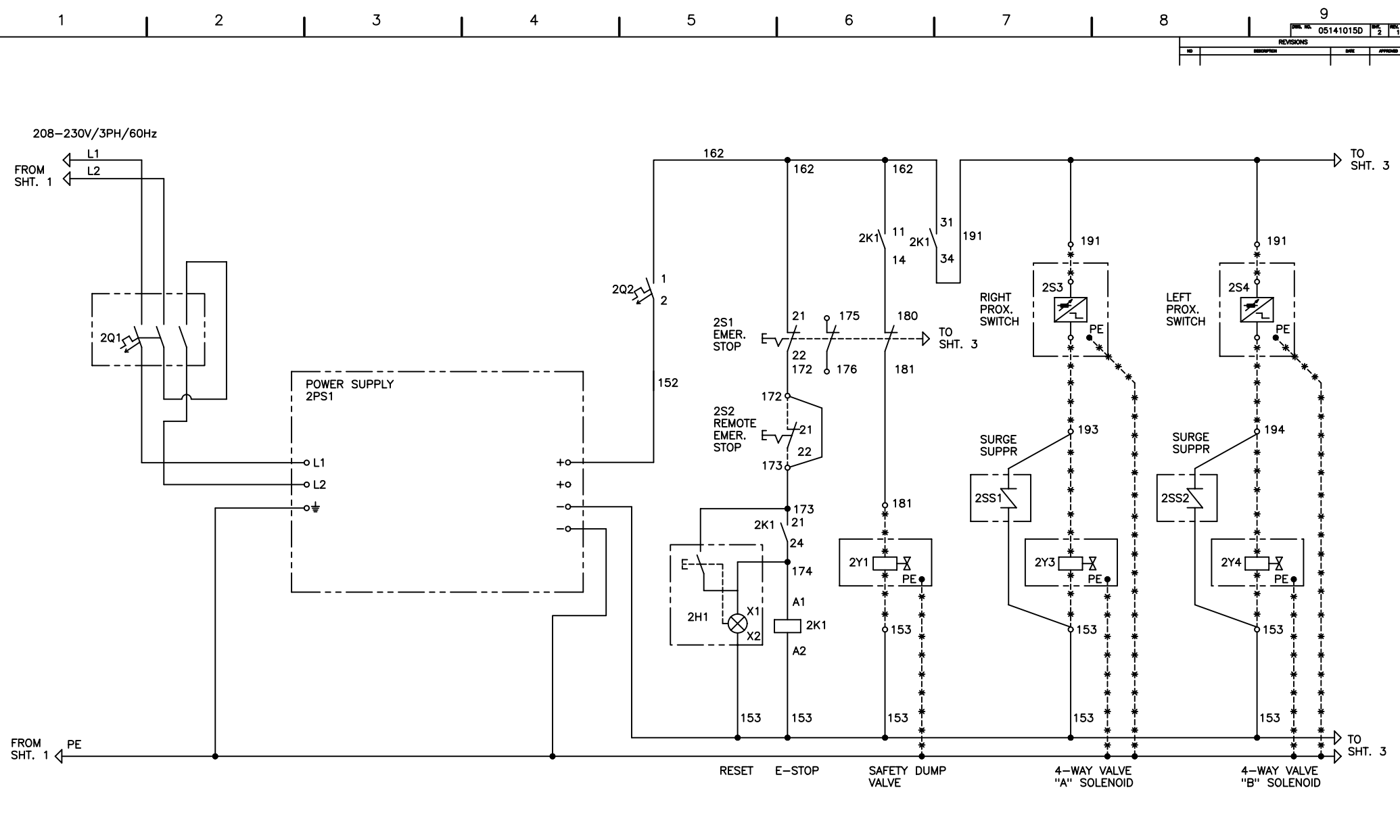

NOTE: ----- WIRING BY CUSTOMER IN ACCORDANCE WITH LOCAL REGULATIONS.
 --* WIRING BY I-R EXTERNAL TO PANEL

Copyright © 2001 Ingersoll-Rand Company All Rights Reserved WARNING ! The export or reexport of this drawing or a product produced by this drawing is subject to U.S. Export Administration regulations and other applicable governmental restrictions or regulations.	PROPRIETARY NOTICE This document contains confidential and trade secret information, is the property of Ingersoll-Rand Co., and is given to the receiver in confidence. The receiver by reception and retention of the document accepts the document in confidence and agrees that, except as authorized in writing by Ingersoll-Rand Co., it will (1) not use the document or any copy thereof or the confidential or the trade secret information therein; (2) not copy the document; (3) not disclose to others either the document or the confidential or trade secret information therein; and (4) upon completion of the need to retain the document, or upon demand, return the document, all copies thereof, and all material copied therefrom.	STANDARD TOLERANCES UNLESS OTHERWISE NOTED: ALL DIMENSIONS ON COARSE DOTTING CONFORM TO .005 BREAK SHARP EDGES AND CORNERS .015 SURFACE FINISH - ✓ STANDARD TOLERANCES: X.1 = ±.063 X.1X = ±.015 X.00X = ±.005 ANGLE = ±.2°	GD&T TO ASME Y14.5M 1994 REF. DIM 05127121D DIM BY ± DIM B RUMBEL 2/01 DIM BY ± DIM M MANN 2/01 DIM APPROVAL -	 ELECTRICAL SCHEMATIC 15HP,SL4, 208-230/3/60 05141015D SHEET 2 OF 3
		TITLE BLOCK NUMBER 1		

REV. NO.		05141015D		REV.	3	DATE	3/28/01
NO.		REVISIONS		DATE	APPROVED		3/28/01
1	REVISED PER REV1016						BR

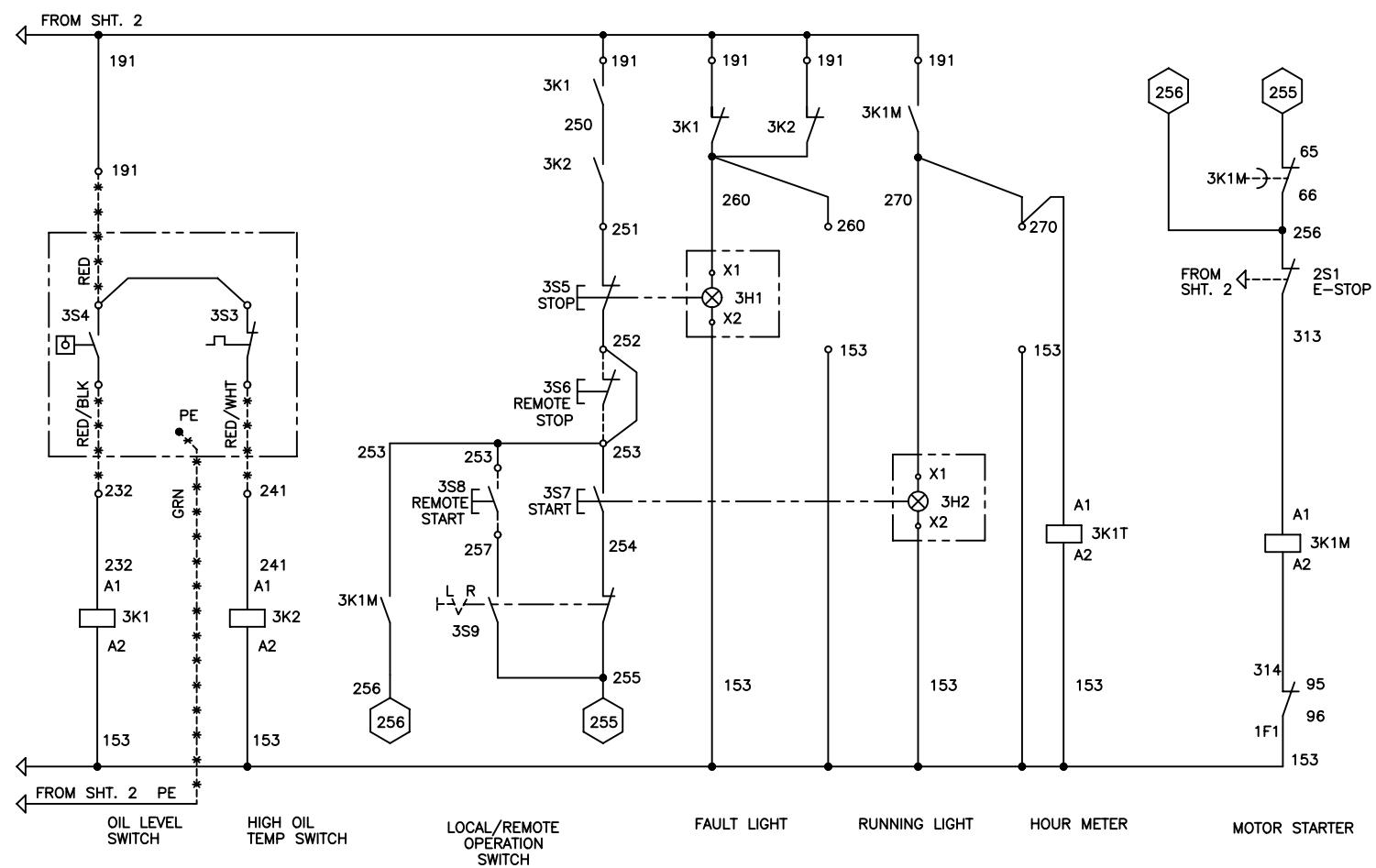

NOTE: ----- WIRING BY CUSTOMER IN ACCORDANCE WITH LOCAL REGULATIONS.
 ----* WIRING BY I-R EXTERNAL TO PANEL

Copyright © 2001 Ingersoll-Rand Company All Rights Reserved	PROPRIETARY NOTICE This document contains confidential and trade secret information, is the property of Ingersoll-Rand Co., and is given to the receiver in confidence. The receiver by reception and retention of the document agrees the document is confidential and agrees that, except as authorized in writing by Ingersoll-Rand Co., it will (1) not use the document or any copy thereof or the confidential or trade secret information therein; (2) not copy the document; (3) not disclose to others either the document or the confidential or trade secret information therein; and (4) upon completion of the need to retain the document, or upon demand, return the document, all copies thereof, and all material copied therefrom.	STANDARD TOLERANCES UNLESS OTHERWISE NOTED: ALL DIMENSIONS ON COMMERCIAL CENTERLINE COMMON TO .005 BREAK SHARP EDGES AND CORNERS .015 SURFACE FINISH - .0005 STANDARD TOLERANCES: X.X = ±.005 X.XX = ±.015 X.XXX = ±.005 ANGLE = ±.5°	GD&T TO ASME Y14.5M 1994	REV. 001	05127121D		
				UNIT BY & DATE	B RUMBEL		DATE
WARNING 1 The export or reexport of this drawing or a product produced by this drawing is subject to U.S. Export Administration regulations and other applicable governmental restrictions or regulations.				ORDERED BY & DATE	M MANN		
				DATE APPROVAL & SIZE	2/01		
						REV. NO.	05141015D
						REV.	1
						DATE	3/28/01
						BY	BR