



STREAMLINE HIGH PRESSURE WATERJET PUMP



OPERATION and SERVICE MANUAL

SL-IV PLUS 60 HP

Manual No. 80072994

NOTICE

This document contains subject matter in which KMT Waterjet Systems has proprietary rights. Recipients of this document shall not duplicate, use, or disclose information contained herein, in whole or in part, for other than the purpose for which this manual was provided.

KMT Waterjet Systems believes the information described in this manual to be accurate and reliable. Much care has been taken in its preparation, however, the Company cannot accept any responsibility, financial or otherwise, for any consequences arising out of the use of this material. The information contained herein is subject to change, and revisions may be issued to advise of such changes and/or additions.

KMT WATERJET SYSTEMS



KMT Waterjet Systems
635 West 12th Street, P.O. Box 231
Baxter Springs, Kansas 66713

Tel. (800) 826-9274
Fax (620) 856-5050

TABLE of CONTENTS

SECTION 1 INTRODUCTION

1	SL-IV Waterjet Pump General Information	1-1
1.1	Physical Description	1-1
1.1.1	Standard Equipment	1-2
1.2	Functional Description	1-3
1.2.1	Functional Features	1-3
1.3	Worldwide Product Support	1-4
1.3.1	Service Department	1-4
1.3.2	Spare Parts	1-4
1.3.3	Questionnaire	1-5
1.4	Safety	1-7
1.4.1	Labels and Abbreviations	1-7
1.4.2	Safety Procedures	1-9
1.4.3	High Pressure (HP) Piping Safety	1-11
1.4.4	Emergency Medical Treatment	1-12

SECTION 2 INSTALLATION

2	Installation	2-1
2.1	Installation Overview	2-1
2.2	Buyer Obligations	2-1
2.3	Seller Obligations	2-1
2.4	Installation Requirements (Utilities)	2-2
2.5	Equipment Location/ Environment	2-2
2.6	Service Connections	2-3
2.7	High Pressure Plumbing Installation	2-5

SECTION 3 OPERATION

3	Operation	3-1
	Main Menu	3-5
	Run Screen	3-5
	Run Screen 2	3-7
	Run Screen 3 Redundant	3-7
	Hours	3-8
	Alarm History Screen	3-9
	Pressure Control Screen	3-10
	Stroke Rate Screen	3-11
	Set Up Screen (2)	3-12
	Maintenance Screen	3-13
	Alarm Screen	3-14
	No Pressure Screen	3-15
	Language	3-16
	(Example)	3-17

SECTION 4 MAINTENANCE

4	Maintenance	4-1
4.1	Scheduled Maintenance	4-3
4.2	General Maintenance	4-3

SECTION 5 TROUBLESHOOTING

5	Troubleshooting	
5.1	Troubleshooting - Electrical	5-1
5.1.1	Pump Will Not Start	5-1
5.1.2	Console Display And Lights Fail To Illuminate	5-1
5.1.3	Pump Quit Running	5-1
5.1.4	No Control Power (24vdc)	5-2
5.1.5	Red Light, Message On Operator's Console	5-2
5.2	Troubleshooting – Hp Water	5-3
5.2.1	Hp Water Signal Abnormal Fluctuation	5-3
5.2.2	Hot Surfaces On Hp Cylinder Components	5-3
5.2.3	Oil Or Water Leaks From HP Cylinder Weep Holes	5-3
5.2.4	Hp Check Valve Leak	5-4
5.2.5	Normal Temperature, But Check Valve Problem	5-4
5.2.6	Hp Cutting Water Too Low	5-4
5.3	Troubleshooting – Lp Water	5-5
5.3.1	Low Booster Pump Pressure	5-5
5.4	Troubleshooting – Hydraulic	5-5
5.4.1	Hot Hydraulic Oil	5-5
5.4.2	Hydraulic Pressure But No High Pressure Water Pressure	5-5
5.5	Special Procedure—Hp Water Check Valve	5-7
5.5.1	Hp Check Valve Troubleshooting	5-7

SECTION 6 LOW PRESSURE WATER SYSTEM

6	Low Pressure Water System	6-1
6.1	Oil Cooling Water Supply	6-1
6.2	Cutting Water Supply	6-1
6.2.1	Normal Operating Condition	6-2
6.2.2	Operation	6-2
6.2.3	Boost Pump Pressure Adjustment	6-6
6.2.4	Low Pressure System Protection	6-6
6.3	Maintenance Overview	6-7
6.3.1	Water Filter Service	6-7
6.3.2	Boost Pump	6-8

SECTION 7 HIGH PRESSURE WATER SYSTEM

7	High Pressure (HP) Water	7-1
7.1	Components	7-1
7.2	Intensifier Disassembly and Reassembly	7-2
7.2.1	HP & LP Water Piping	7-3
7.2.2	HP Cylinder “Jug” (HP Cyl., Sealing Head, Flanges, & Studs	7-4
7.2.3	Stud Nuts and End Flange, Sealing Head	7-5
7.2.4	HP Plunger Seal Service-- Disassembly / Re-assembly	7-6
7.2.5	Plunger and Hydraulic Cartridge Removal and Installation	7-10
7.2.6	Hydraulic Cylinder Head & Hydraulic Piston	7-11
7.3	Intensifier Subassemblies Inspection & Repair	7-13
7.3.1	Discharge HP Check Valve	7-14
7.3.2	Inlet Check Valve	7-16
7.3.3	Sealing Head	7-18
7.3.4	HP Cylinder	7-19

7.3.5	Plunger	7-20
7.3.6	Hydraulic Seal Cartridge	7-21
7.3.7	Hydraulic Piston	7-23
7.3.8	Hydraulic Cylinder	7-27
7.4	HP Dump Valve	7-28
7.5	HP Attenuators	7-28
SECTION 8 ELECTRICAL SYSTEM		
8	Electrical System	8-1
8.1	Electrical Overview	8-1
8.1.1	Motor Starter Circuit	8-3
8.1.2	Control Circuits and Logic	8-4
8.1.3	Operation	8-6
8.1.4	Control Power Circuits	8-8
8.1.5	(Optional) Proportional Pressure Control	8-8
8.1.6	(Optional) Modem	8-8
8.2	Maintenance Overview	8-10
8.2.1	Proximity Switch Service	8-10
8.2.2	Optical Relay Switch Service	8-11
SECTION 9 HYDRAULIC SYSTEM		
9	Features	9-1
9.1	Components	9-1
9.2	Operation	9-3
9.2.1	Hydraulic Pressure Adjustment	9-3
9.2.2	Hydraulic System Pressure Protection	9-4
9.3	Motor/ Hydraulic Service Maintenance	9-5
9.3.1	Motor Service	9-6
9.3.2	Manifold Service	9-6
9.3.3	Motor/Pump Coupling-Spline Lubrication	9-6
SECTION 10 RECIRCULATION SYSTEM		
10	Recirculation System	10-1
10.1	Components	10-1
10.2	Operation	10-1
10.3	System Pressure Protection	10-2
10.4	Maintenance Overview	10-3
SECTION 11 SPECIFICATIONS		
11	Specifications	11-1
11.1	Equipment Specifications	11-3
11.2	Torque Specifications	11-4
11.3	Cutting Water Specifications	11-5
11.4	Cooling Water Specifications	11-5
11.5	Orifice Support Capacity	11-5
SECTION 12 PARTS LISTS		
12	Parts Lists and Drawings	
	Electrical Schematic Diagram	
	Hydraulic Schematic Diagram	
ACCESSORIES		

1 SL-IV Waterjet Pump General Information

The Streamline SL-IV Waterjet Pump, maintains the level of component reliability and ease of installation and maintenance that have made the Streamline waterjet pumps the standard of the industry for both water and Hydroabrasive™ applications.

The SL-IV Waterjet Pump uses low pressure water, which meets certain quality requirements, and increases the pressure up to 4,136 bar (60,000 psi) for ultra-high-pressure waterjet cutting, hydroabrasive cutting, cleaning, surface preparation, etc.

This manual provides information for installation, operation, and maintenance of the SL-IV Waterjet Pump.

Basic configurations of SL-IV intensifier pumps discussed in this manual are listed in Table 1-1 below.

TABLE 1-1. Model Data- SL-IV Waterjet Intensifier Pumps							
Motor Horsepower Rating		Intensifier Model	HP Water Max Oper Pressure (psi)	Plunger Quantity and Diameter (inches)		Frame Dim "L" (inches)	Redundant Option Available?
Hp	Kw			7/8 (0.875") [22 mm]	1-1/8 (1.125") [29 mm]		
30	22	SL-IV 30+	60,000	2	-	67.75	Yes
50	37	SL-IV 50+		2	-	67.75	Yes
60	45	SL-IV 60+		2	-	77.75	Yes
75	56	SL-IV 75+		-	2	77.75	Yes
100	75	SL-IV 100D		4	-	77.75	No
100	75	SL-IV 100S		-	2	77.75	Yes

1.1 Physical Description

The waterjet pump is equipped with one or two hydraulically operated intensifiers, one or two liters of high pressure attenuator volume, a motor/hydraulic pump assembly, an electric starter panel, control sensors, solenoids and logic, control interface panel, a low pressure water booster pump, and a low pressure water filter.

The high pressure system is conveniently mounted on a drip pan. All service components are easily accessible from at least two sides simplifying maintenance. The entire high pressure system can be removed from the rest of the unit quickly for maintenance and serviceability.

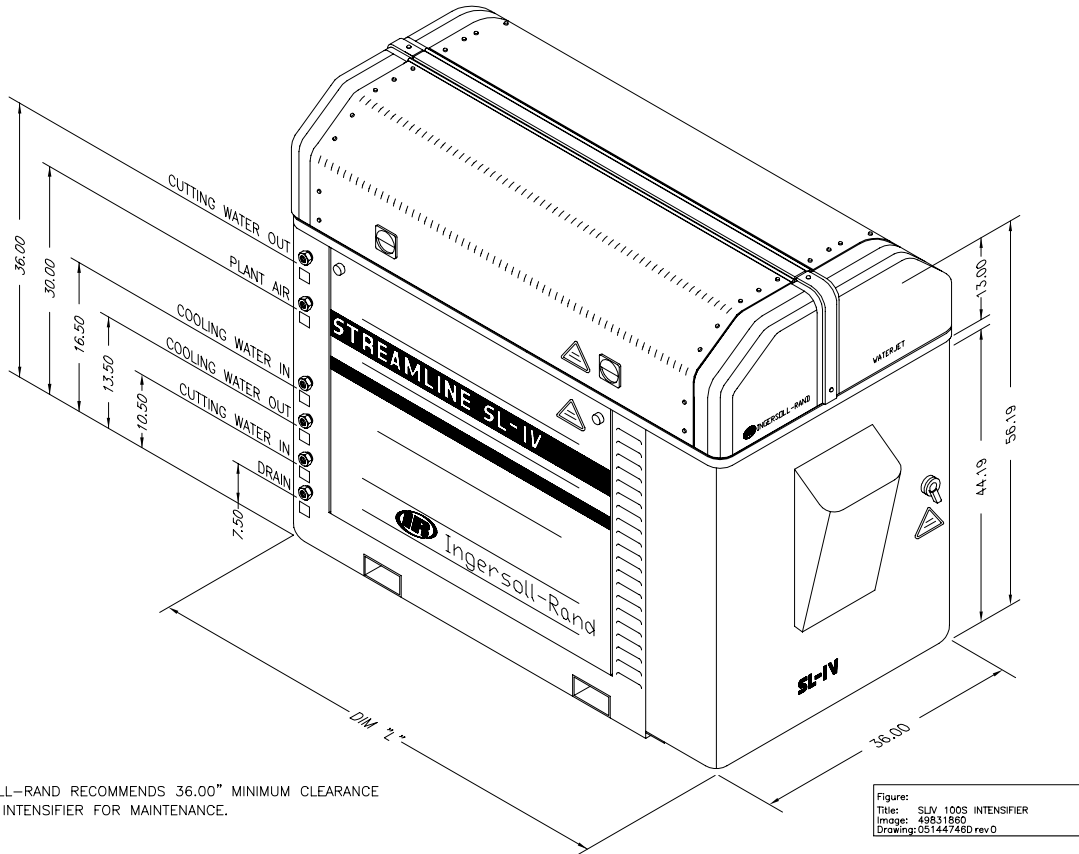

1. INGERSOLL-RAND RECOMMENDS 36.00" MINIMUM CLEARANCE AROUND INTENSIFIER FOR MAINTENANCE.

Figure: SLIV 100S INTENSIFIER
Title: 49831880
Image: 49831880
Drawing: 051447480 rev 0

1.1.1 Standard Equipment

Following is an overview of the standard equipment for the SL-IV Waterjet Pump:

- Variable displacement, pressure compensated hydraulic pump
- Water pressure booster and filtration system with 10-micron double-length filter
- High efficiency heat exchanger in independent recirculation pump circuit
- Stand-alone unit with built-in motor starter (wye delta or across the line).
- High pressure safety dump valve
- Dual pressure compensator
- 1 or 2 liters of high pressure attenuator volume
- Microprocessor control with diagnostic capability
- Water inlet shut-off valve
- Booster pump
- Integral water and oil drip pans
- Electrical remote control interface

1.2 Functional Description

The SL-IV Waterjet Pump meets the automotive and industrial markets needs of low to high volume production of water jet pumps. The maximum HP water pressure is limited by a hydraulic relief valve that is factory certified and sealed. No HP rupture disk is required.

HP water is produced by an intensifier consisting of two HP water cylinders mounted to a hydraulic cylinder. Ceramic plungers (2 per intensifier) attach to the hydraulic piston and extend into each HP cylinder. With two intensifiers mounted on one SL-IV frame, both may operate simultaneously (dual) or one may serve as stand-by for the other (redundant). Piston travel is sensed electronically by proximity switches which control hydraulic flow to/from the double-acting hydraulic piston/cylinder.

Refer to Table 1-2 for HP water performance limits for various power levels of SL-IV waterjet pumps.

TABLE 1-2 HP WATER PERFORMANCE- SL-IV WATERJET INTENSIFIER PUMPS				
Horsepower	55,000 psi		60,000 psi	
	Orifice Size (inches)	Flow Rate (gpm)	Orifice Size (inches)	Flow Rate (gpm)
30	0.011	0.60	0.010	0.52
50	0.014	0.98	0.013	0.88
60	0.015	1.12	0.014	1.02
75	0.017	1.44	0.016	1.33
100	0.020	2.00	0.019	1.88

The recirculation hydraulic loop for cooling and filtering oil runs continuously whenever the motor is running.

1.2.1 Functional Features

Following is a list of SL-IV Waterjet Pump features:

- 4,136 bar (60,000 psi) operating pressure
- Electronic reversing
- 24 vdc safety control
- Standard high pressure water leak detection
- Standard dual pressure control facilitates hole piercing and kiss cut applications
- Exclusive long slow stroke
- Cartridge type hydraulic seal
- Low pressure water booster pump and filtration
- Reduced cooling water requirements
- Choice of English, German, Spanish, Swedish and Italian readouts as standard
- Meets CE requirements

1.3 Worldwide Product Support

The KMT Waterjet Systems Service Department serves the customer, by providing:

- Supervision of equipment installation, start up, and training for the number of days specified in the quotation, and per approved project. Additional time requested will be invoiced on a per diem basis, plus travel and normal living expenses.
- Field Services: on-site technical support is available on request. These services are invoiced on a per diem basis, plus travel, and normal living expenses.
- Technical Assistance: the Service Department is available for technical assistance by phone.
- Training: the Service Department conducts periodic training sessions at KMT Waterjet designated training locations. On-site training is also available.

1.3.1 Service Department

To contact the KMT Waterjet Service Department:

USA: Customer Service Manager

KMT Waterjet Systems

P.O. Box 231

635 West 12th Street

Baxter Springs, KS 66713

USA

Phone: (620) 856-2151

Fax: (620) 856-5050

Email: wj_service@kmtwaterjet.com

Europe: Technical Manager

KMT Waterjet Systems GmbH

Wasserstrahl-Schneidetechnik

Auf der Laukert 11

D-61231 Bad Nauheim

Germany

Phone: 49-(0)6032-997-117

Fax: 49-(0)6032-997-270

Email: order.service@kmt-waterjet.com

1.3.2 Spare Parts

KMT Waterjet maintains a well stocked Spare Parts Department staffed by well trained knowledgeable personnel. Emergency shipment is available.

Contact the Customer Service Department of KMT Waterjet.

1.3.3 Questionnaire

The following equipment and service manual questionnaire will provide information to allow us to serve you better. Please complete them at your convenience and return to the applicable Customer Service Department as shown above.

EQUIPMENT AND SERVICE MANUAL QUESTIONNAIRE

We have just installed a new SL-IV Waterjet Pump at your location. We are interested in your initial impressions of the unit and its installation. Please take a few moments and answer the following questions.

1. General Appearance
Was unit received in good condition? Yes No
Comments: _____

2. Is the unit a convenient size? Yes No

3. Controls
 - a. Are the controls user friendly? Yes No
 - b. Is the unit easy to operate? Yes No
Comments: _____

4. Performance
 - a. Does the unit perform smoothly and meet your expectations? Yes No
Does the unit run quietly? Yes No
Comments: _____

5. Did installation and start-up go smoothly? Yes No
Comments: _____

6. What feature(s) do you consider the most significant with this unit?
Quiet Operation _____
Appearance _____
Performance (Operation) _____
Repair/Maintenance _____
Other _____

7. What areas need improvement?
Appearance _____
Servicability _____
Performance _____
Other _____

Manual Organization

1. Does the table of contents help you find topics easily? Yes No

Comments: _____

2. Is the information well organized? Yes No

Comments: _____

3. Is the page layout suitable for the material being presented? Yes No

Comments: _____

Graphics

1. How do you rate the quality and quantity of the photos/illustrations? Yes No

Comments: _____

Text

1. Does the information in the manual adequately explain how to operate and service the equipment? Yes No

Comments: _____

2. Are there paragraphs or procedures you feel need clarification? Please identify them by page number and add your comments. Yes No

Comments: _____

3. Is there anything you would add or delete from the manual to make it more useful? Yes No

Comments: _____

4. Is there any information that should receive more emphasis? Yes No

Comments: _____

Name: _____ Title: _____

Company _____









Address: _____

1.4 Safety

Safety procedures and safe practices must be followed during installation, operation, and maintenance of the waterjet pump. In this section we have provided label and sign descriptions used in this manual, as well as recommended safety procedures.

1.4.1 Labels and Abbreviations

The following describes hazard classifications of the waterjet pump.

	<p>Indicates the presence of a hazard, which can cause personal injury, or property damage if the caution instruction is ignored.</p>
	<p>Indicates the presence of a hazard, which can cause severe personal injury, death, or substantial property damage if the warning instruction is ignored.</p>
 <p>(ISO 3021)</p>	<p>High pressure waterjet can cause eye injury. Wear eye protection when operating or working near machine.</p>
	<p>Hazardous noise can cause hearing loss. Wear ear protection when operating or working near machine.</p>
 <p>(ISO 6010)</p>	<p>Hazardous voltage within can cause injury or death. Disconnect and lockout main power before opening cabinet.</p>
	<p>Start/Control Power On</p>
	<p>Stop</p>
 <p>(ISO 1024)</p>	<p>Hot Surface inside. Do not touch.</p>
 <p>(ISO 6060)</p>	<p>Do not operate with guard removed. Replace Guard before operating machine.</p>

Rear of Waterjet Pump

- HP Water "OUT"
- Plant Air "IN"
- Cooling Water "IN"
- Cooling Water "OUT"
- Cutting Water "IN"
- Drain

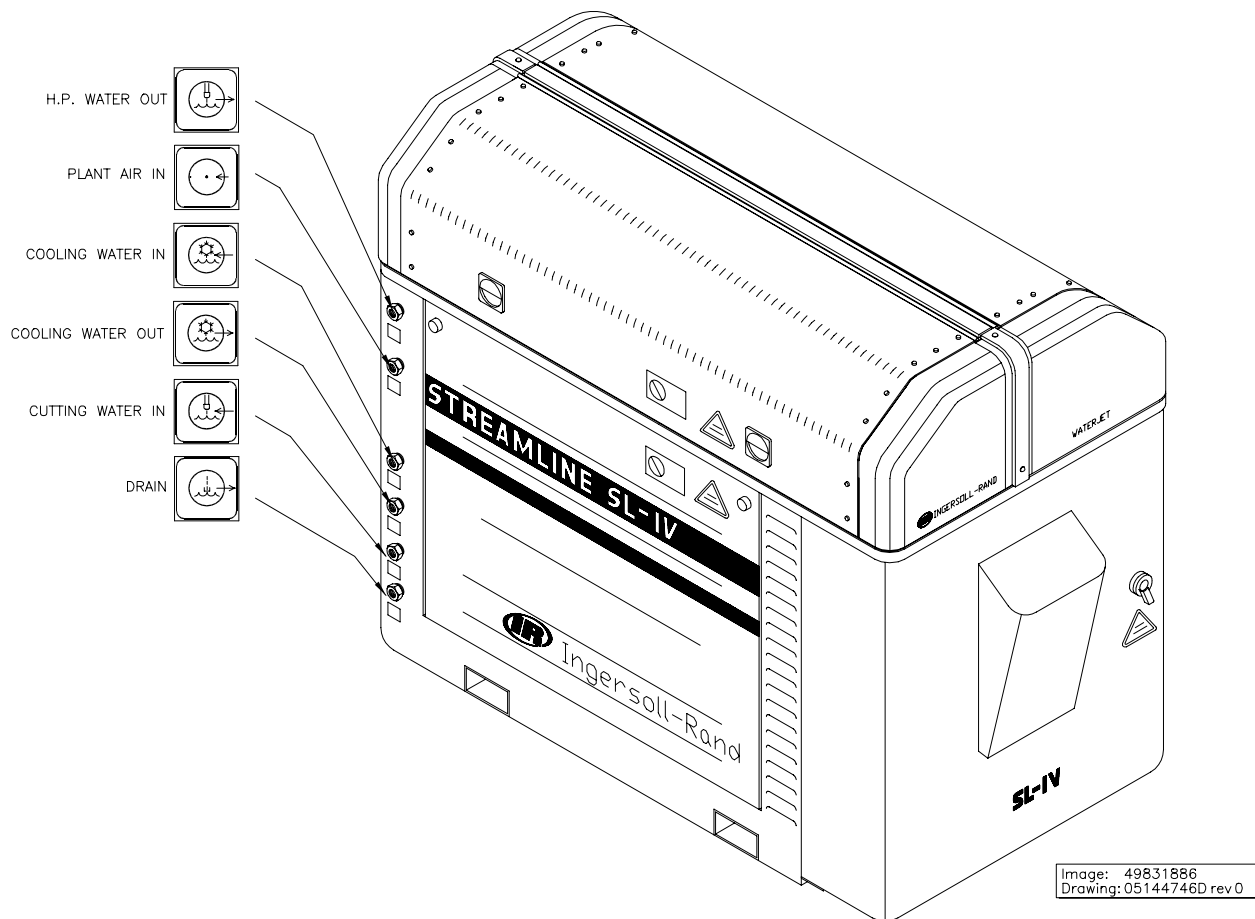

1.4.2 Safety Procedures

Safety procedures must be observed while working on the pump, or any high pressure part of the installation. **Service should only be performed by qualified personnel.**

- The high pressure water, 4,136 bar (60,000 psi) in waterjet cutting systems should not be a cause for concern. Users must have due respect for these pressures and use proper SAFETY PROCEDURES and SAFE WORK HABITS.
- Everyone associated with the waterjet cutting system must realize that the force of the waterjet cutting stream can penetrate many dense or strong materials.
- Keep all untrained people away from the waterjet cutting area. Use barriers or partitions if needed.
- Safety glasses must be worn at all times in the waterjet cutting area.
- All **EMERGENCY STOP** buttons must be checked periodically. The normal operating position is pulled out.
- To check: turn on power and activate the **EMERGENCY STOP** buttons by pushing them in to see if the power goes off. Each device should be checked on a specified schedule. Each time the device is checked, it must function or be replaced before operating the system.
- Apply High Purity Goop (P/N 10084440) to all threaded high pressure connections. All tubing, fittings and bolted connections should be torqued to recommended values. Do NOT attempt to tighten or loosen a HP water fitting when the circuit is pressurized, see High Pressure (HP) Piping Safety.
- All high pressure leaks must be repaired immediately.
- Inspect all equipment on a scheduled basis.
- Before performing any maintenance on the unit, **MECHANICALLY LOCK THE MAIN CONTROL POWER OFF**, and assure the high pressure has been bled off.
- If steam or fog is noticed inside the clear top cover, this indicates a high pressure leak. Turn off intensifier and bleed pressure before lifting the cover.
- Pressing the emergency stop button turns off the control power to the intensifier, stops the intensifier pump, and bleeds high pressure water through the dump valve. Depressurization of the high pressure system can be heard when the dump valve opens as a loud hissing that fades quickly as the pressure drops.



Never do any work on the unit without making sure the electrical panel disconnect is locked out with a padlock in the OFF position.



Never work on any high pressure component, or loosen any high pressure fittings without first bleeding the system and assuring there is no high pressure water present.



Make sure the safety devices are operational. To panic stop the pump and bleed the high pressure, the EMERGENCY STOP buttons must be pushed in. The system pressure dump valves must be open.



Do not attempt to touch or be exposed to high pressure water. The high pressure water will penetrate all parts of human body without exception.



The liquid stream or material ejected by these extreme pressures can injure or kill.



Do not operate the intensifier with any of the covers opened or removed.

1.4.3 High Pressure (HP) Piping Safety

High pressure piping must be installed without torsional or bending stresses. Proper supports and guides must be provided. 9/16" outside diameter HP tubing and fittings are recommended between the pump and the cutting station. This large tubing size will reduce vibration, strain and motion between the pump piping and the cutting area. The larger piping diameter also reduces pressure drop, and pressure pulsation.



Do not try to repair a leak in a HP water fitting when it is pressurized. Always shut off the power and bleed the HP water before doing maintenance on HP components. Weep holes are provided to release HP water if leakage occurs at a sealing surface. If a fitting is loosened with HP water present, a jet of HP water will exit the nearest weep hole with **possible hazardous results**.



Use extreme caution when handling high pressure equipment. Possible failure from fatigue cracking or over-pressurization can result in a hazardous high pressure leak, or component failure.



A flexible 1/4" HP tube (whip) is frequently used on the cutting system to allow cutting nozzle movement. Supports and guides for the whip must be used, anti-vibration fittings and proper support must be provided to prevent failures from external loads (non-water related stresses).



When tightening or loosening HP connections, always use a supporting wrench to avoid bending forces or stress on the connection. Do not exceed recommended torque values



High pressure piping and fittings designed to 4,100 bar (60,000 psi) must always be used. Failure to do so may lead to catastrophic component failure, which can cause equipment damage, injury or even death.

1.4.4 Emergency Medical Treatment

An information card to aid treating a waterjet injury is included in the binder of each manual. The card is shown below. Contact the address shown for additional cards.

(Front Side)

<p style="text-align: center;">Medical Alert</p> <p style="text-align: center;">This card is to be carried by personnel working with high pressure waterjet equipment. Obtain medical treatment immediately for ANY high pressure waterjet injuries.</p> <p style="text-align: center;"><u>KMT Waterjet Systems</u> P.O. box 231, 635 West. 12th Street Baxter Springs, KS 66713 (620) 856-2151</p>

(Back Side)

<p style="text-align: center;">This person has been working with water jetting at pressures to 55,000 psi (374MPa, 3740 bar, 3867 Kg/cm²) with a jet velocity of 3,000 fps (914 mps). Foreign material (sand) may have been injected with water. Unusual infections with microaerophilic organisms occurring at lower temperatures have been reported, such as gram negative pathogens as are found in sewage. Bacterial swabs and blood cultures may therefore be helpful. This injury must be treated as an acute surgical emergency and be evaluated by a qualified surgeon. Circulation may be compromised, therefore, DO NOT APPLY HEAT TO INJURED PART. For first aid: (1) Elevate injured part (2) Antibiotics (3) Keep injured person NPO.</p>
--

Section 2 INSTALLATION**2 Installation**

The installation, start-up, operation, and maintenance of the SL-IV+ waterjet pump requires complete reading and study of this manual to understand the system in detail.

2.1 Installation Overview

Read the manual and become familiar with the operation of each component and its nomenclature.

Understand the complete system and its function before operating it.

Safety procedures and safe practices must be followed during installation, operation, and maintenance of the SL-IV+ waterjet pump.

2.2 Buyer Obligations

Equipment installation requires cooperation between the user and KMT Waterjet Systems. If on-site support is requested, the KMT Waterjet Service Department will require the following tasks be accomplished before arrival at the customer site:

- The waterjet cutting equipment should be uncrated, positioned and leveled, with electrical and fluid services brought to the unit.
- Provide and install power drops with fused disconnects sized to the equipment power requirements.
- Provide and install pneumatic drops with manual shutoff valves.
- Provide all mounting and support brackets and hardware for high pressure tubing runs.
- Provide and install water conditioning equipment necessary to meet water purity requirements. Provide and install manual shutoff valves.
- Provide and install necessary cooling water inlet/outlet, and drain water connections to the intensifier pump, and/or cutting equipment and manual shut-off valves.
- Provide suitably located and sized drains and proper disposal of waste water.
- Provide, install and connect wiring between the intensifier pump(s), and the cutting station control system.
- KMT Waterjet supplies a pre-filled hydraulic system. If fluid is low or empty due to leakage during transit, the system must be filled per specifications.

2.3 Seller Obligations

If KMT Waterjet Service is requested, the following tasks will be the responsibility of the KMT Waterjet technician at installation.

- Insure site preparation is satisfactory.
- Remove internal strapping and blocking material.

- Insure that power is connected prior to equipment turn on.
- Insure that connections have been made for water and pneumatic service.
- Test motor rotation direction and correct if necessary.
- Check and test electrical signal connections between intensifier pump and cutting area.
- Power up and check out pump (and cutting station, if supplied by KMT Waterjet) for proper operation.
- Set booster pump discharge pressure.
- Install and test high pressure plumbing.
- Follow the standard test procedure to insure satisfactory performance.
- Train maintenance personnel in the performance of maintenance and repair procedures.
- Sign off the installation and testing on the KMT Waterjet standard acceptance document.

2.4 Installation Requirements (Utilities)

Environment:

The SL-IV+ waterjet pump must be installed indoors. Ambient conditions must not exceed maximum specifications.

Moving:

The SL-IV+ waterjet pump has provisions to be moved with a forklift. Check weight specifications.



The waterjet pump is top heavy. Avoid situations that could result in the equipment tipping or overturning.



Electrical connections must be made by qualified personnel, and must meet national and local electrical codes.

2.5 Equipment Location/Environment

Space Requirements:

There should be a minimum of 900mm (36 inches) clearance on all sides of the pump to facilitate service.

Electrical Wiring:

Power supplied to the pump must be in accordance with national and local electrical codes. See specifications or requirements.

Insure that the service voltage and ampacity are proper for this SL-IV+ pump. Voltage fluctuations in excess of +/- ten percent of nominal voltage may damage the SL-IV+ Pump and will void the warranty. Refer to Section 11, "**Specifications**".

Control Wiring:

Wiring for remote control of the pump must be in accordance with national and local electrical codes. The SL-IV+ Waterjet Pump has a 24vdc electrical control system and has a connector port for remote operation wiring on the pump control enclosure.

2.6 Service Connections**Cooling Water IN/OUT:**

Supply plumbing must be properly sized to handle the necessary flow and pressure. Piping must meet national and local piping codes.

If municipal or well water is used for cooling, insure that the supply will flow a minimum of 3 gallons per minute at a minimum of 30 PSIG under maximum usage conditions.

If a facility-wide chilled water (active or evaporative tower) system is used for cooling, insure that there is a minimum of 30 PSIG pressure differential between the facility supply and the return (discharge) plumbing. Installation of an in-line pressure boosting pump may be necessary to provide adequate cooling flow.

Cutting Water IN:

Supply piping must be properly sized to handle the necessary flow and pressure, and must be capable of providing a minimum of 30 psi at maximum flow demand to insure adequate supply to the intensifier. Piping must meet national and local piping codes.

Prior to operation, insure that the cutting water meets minimum standards listed in Section 11 “**Specifications**”. Operation without proper water quality will shorten the life of certain intensifier parts and void their warranty.

Use only plastic or copper plumbing from the cutting water source to the SL-IV PLUS pump cutting water supply filter.

Thoroughly purge the cutting water supply plumbing prior to connecting to the SL-IV+ pump to avoid construction residue contaminating the pump.

HP Water OUT:

Properly rated, sized, and supported high pressure (HP) piping must be used to transport the high-pressure water from the SL-IV+ pump to the point of use.

If new HP discharge piping is installed, all burrs that might come loose under high pressure must be carefully removed, and the tubing sections purged with compressed air prior to assembly. Further, it is strongly recommended that the HP piping be purged under high pressure operating conditions, using a large, cheap orifice. Contamination from the HP piping will be released when the tubing expands under pressure. If the HP piping is not purged, expect to have early HP valve and orifice failures.

All stainless steel parts should have High Purity Goop (P/N 10084440) applied to the threads and contact surfaces prior to assembly. Do NOT USE ANY OTHER ANTI-SEIZE COMPOUND. Failure to use High Purity Goop will result

in galling of the parts, and will generally render them unusable. Do not use High Purity Goop on ANYTHING but stainless steel!

Drain:

Cutting water released in the activation of EMERGENCY STOP will be discharged from the intensifier drain port and must be piped to an appropriate location (i.e. sewer line). The volume of water released will be minimal, and will not require high-pressure plumbing. Piping must meet national and local piping codes.

Compressed Air:

The facility air connection to the SL-IV Pump should provide clean, dry air at 85 PSIG. Air usage is minimal and less than 1 SCFM.

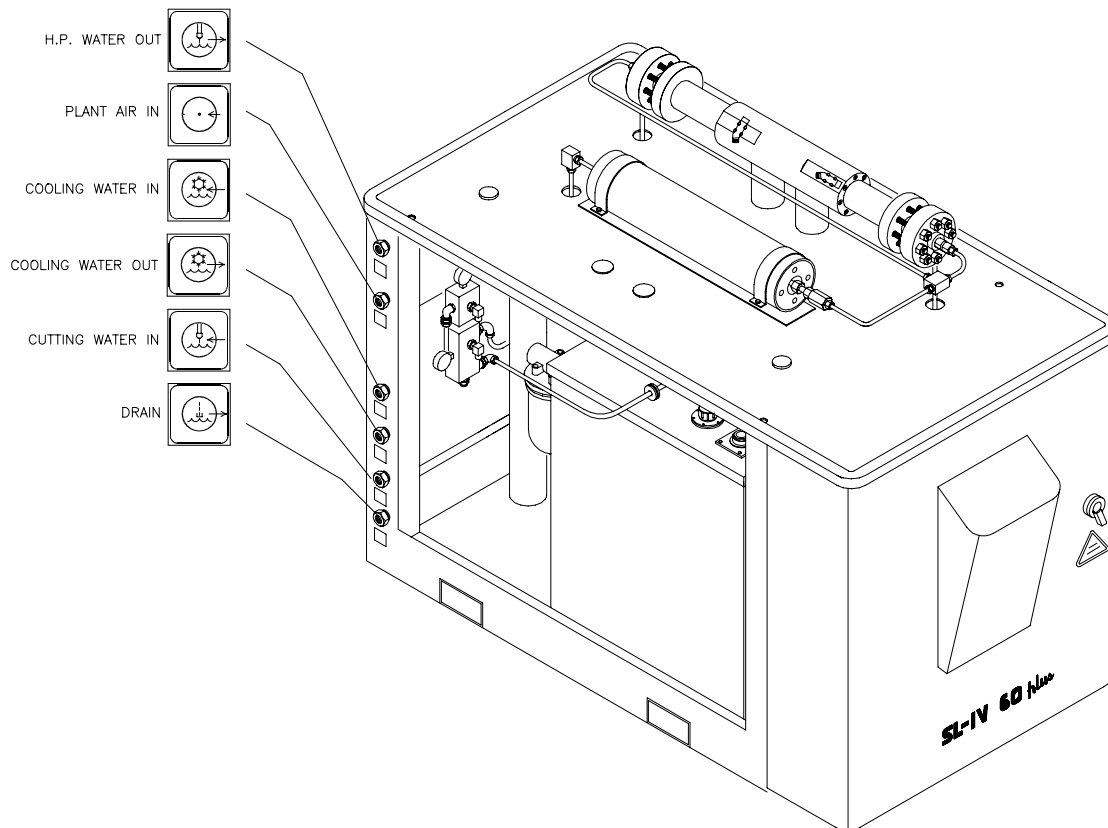

Figure:
Title: SERVICE CONNECTIONS
Image: 80074818
Drawing: rev

2.7 High-pressure Plumbing Installation

HP Tube Coning and Threading Procedures

Determine Tube Length - Measure the distance (L) between the fittings, then add two times the tube engagement length in the following table. Cut tubing to length and deburr.



High-pressure piping and fittings rated for 4,138 bar (60,000 psi) must be used. Failure to do so may result in component failure causing equipment damage, personal injury, or death.

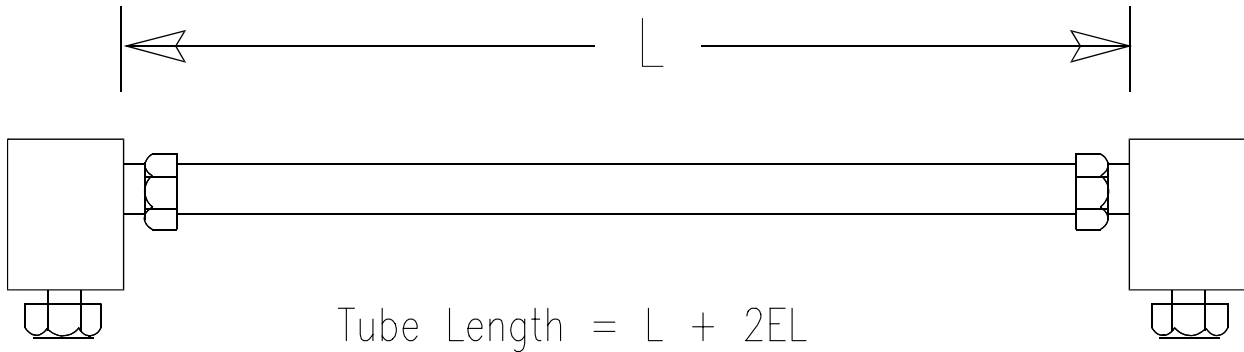

Image: 05119524
Drawing: HP TUBING rev --

Tube Engagement Length

HP Tube Diameter (inch)	Engagement Length (EL) mm (inch)
1/4"	12.7 (0.50)
3/8"	17.5 (0.69)
9/16"	21.3 (0.84)

Cone and Thread Tube

Cone and thread both ends of the tube per following diagram and procedure.

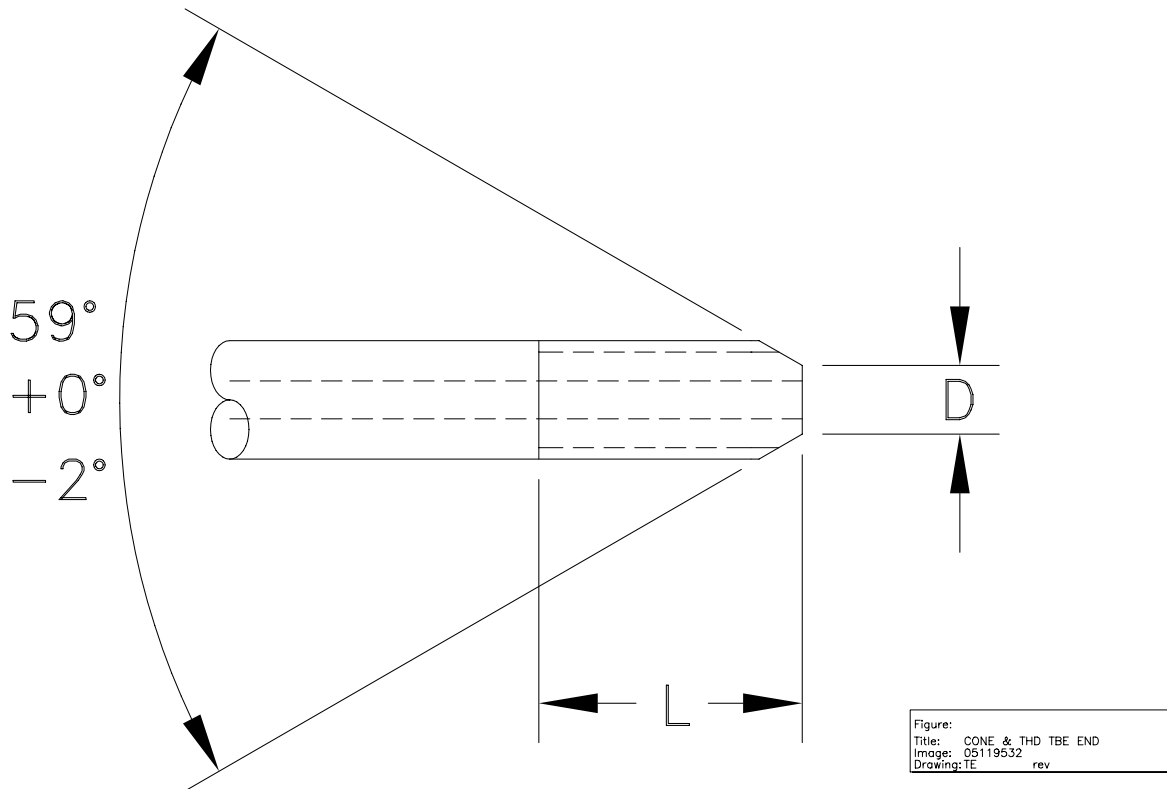

Cone and Thread Dimensions

O.D. Size mm (inch)	I.D. size mm (inch)	D (max) mm (inch)	L (max) mm (inch)	Thread NF-LH
6.35 (1/4")	2.11 (0.083)	3.58 (0.141)	14.3 (0.562)	(1/4"- 28)
9.52 (3/8")	3.18 (0.125)	5.56 (0.219)	19.1 (0.750)	(3/8"- 24)
14.27 (9/16")	4.78 (0.188)	7.14 (0.281)	23.8 (0.938)	(9/16"- 18)

To cone the tubing, use the following figure as reference.

Cone and Threading Tool

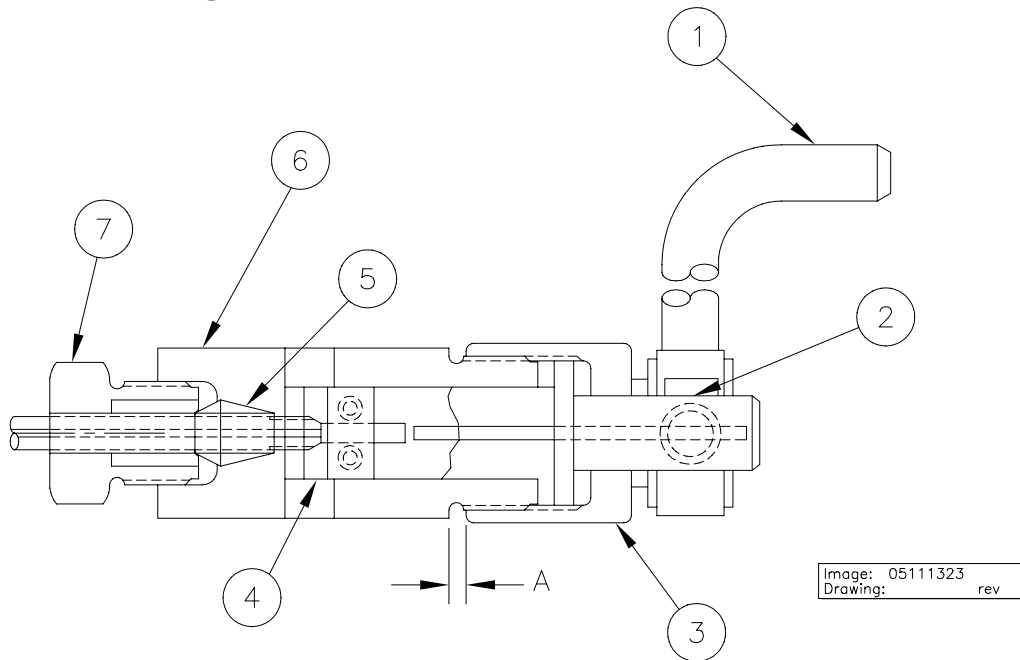

Item Description

- (1) Cutter Handle (2) Cutter Support (3) Feed Nut
 (4) Cutting Blades (5) Collet (6) Housing (7) Gland Nut

Tube Size (inch)	1/4"	3/8"	9/16"
A mm (inch)	3.30 (0.13)	4.07 (0.16)	7.11 (0.28)
Coning Tool (IR Part)	10079556	10097418	10079663
Threading Tool (IR Part)	10079697	10097434	10097442

Coning

- Place the appropriate size coning tool in a vise so that lubricant can flow to cutting blades (4).
- Set feed nut (3) location as shown in dimension A.
- Slide tubing through collet (5) until end contacts cutting blades (4) and tighten gland nut (7) just enough to firmly grip tubing.
- Turn feed nut (3) counterclockwise to back cutters away from tubing, and tighten gland nut (7) with wrench.
- Apply cutting oil through the opening in the coning tool. A medium weight cutting oil having high sulfur content is recommended. Use cutting oil freely throughout the cutting operation to prevent dulling the coning blade.
- Turn the feed nut (3) clockwise until cutting blades (4) contact end of tubing.
- Rotate the cutter handle (1) in a clockwise direction while simultaneously turning the feed nut (3) in a clockwise direction at a rate to assure that the cutting blades (4) are taking a light cut at all times.
- Continue rotating cutter handle until feed nut bottoms on housing (6), then rotate cutter handle several more revolutions to face-off the end of the cone.
- Unscrew the feed nut (3), and remove the blade spindle (2) from the coning tool. Loosen the collet, slide the tubing (8) into the housing (6) until it extends approximately 100mm (4 inches) and then retighten the collet.

Threading

Place the appropriate sized threading tool on the coned end of the tubing, large end forward. Apply pressure to start the cutting action and rotate the die holder counterclockwise until the threads are cut per the cone and thread dimension table.

HP Tube End Connection - Regular

The following type of connection is for general applications, where the only load on tubing is due to internal pressure.

1. Slip the gland nut (2) on the tubing (1) as shown and lubricate the threads with a light coat of High Purity Goop. Thread the collar (3) on the tubing until one to two threads are exposed between the collar (3) and the tube cone.
2. Lubricate the male threads of the gland nut with High Purity Goop. Insert the tubing assembly into the fitting, engage the gland nut and tighten finger-tight.
3. Tighten the gland nut to the specified torque given in the torque table.

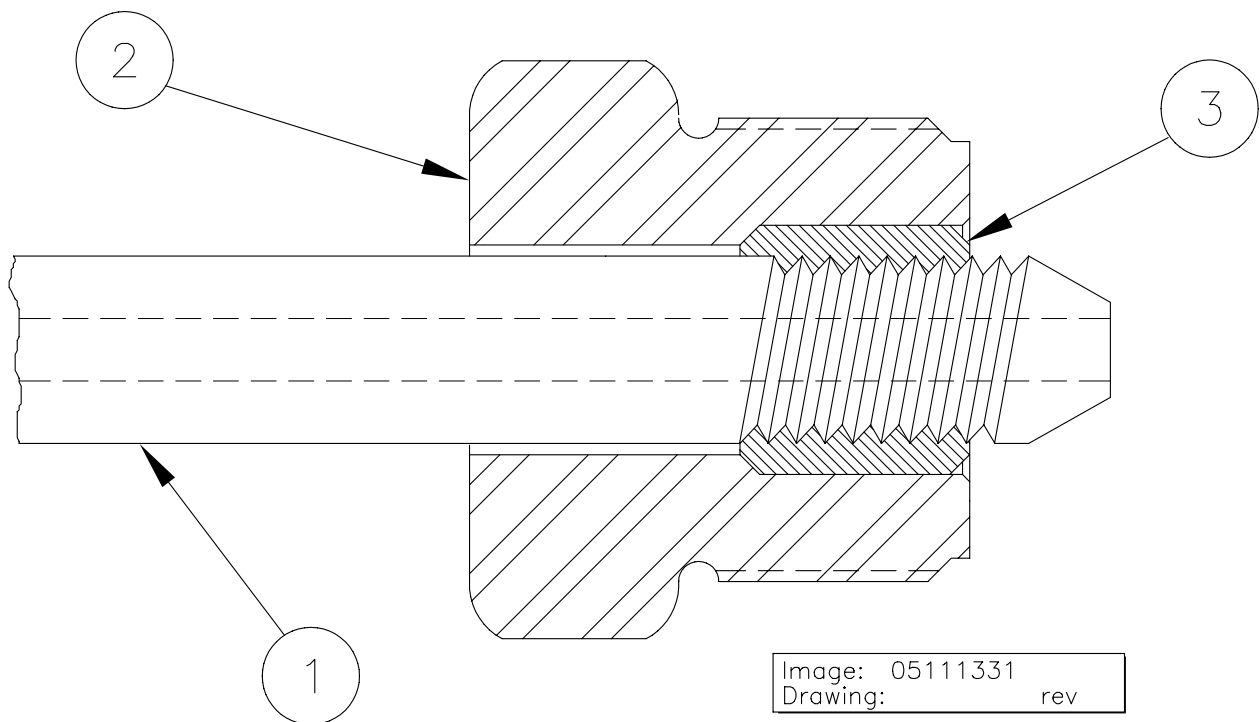

HP Tube End Connection - Antivibration

The following type of connection must be used when tubing will be subjected to vibration, rotation, movement, and side loads (i.e. whip tubing). Lubricate threads as above.

**WARNING**

Do not depend on end connection to take the tubing load alone. Proper piping support and guide must be provided.

**WARNING**

Do not subject the tubing to torsional (rotational) stress. To do so will cause premature failure.

1. Slip the gland nut (2) and the anti-vibration collet (4) on the tubing (1). Thread the collar (3) on the tube until one to two threads are exposed between the collar and the tube cone.
2. Lubricate the male threads of the gland nut with High Purity Goop. Insert the tubing assembly into the fitting, engage the gland nut and finger tighten.
3. Tighten the gland nut to the specified torque according to the table of Recommended Torque Values in this section.

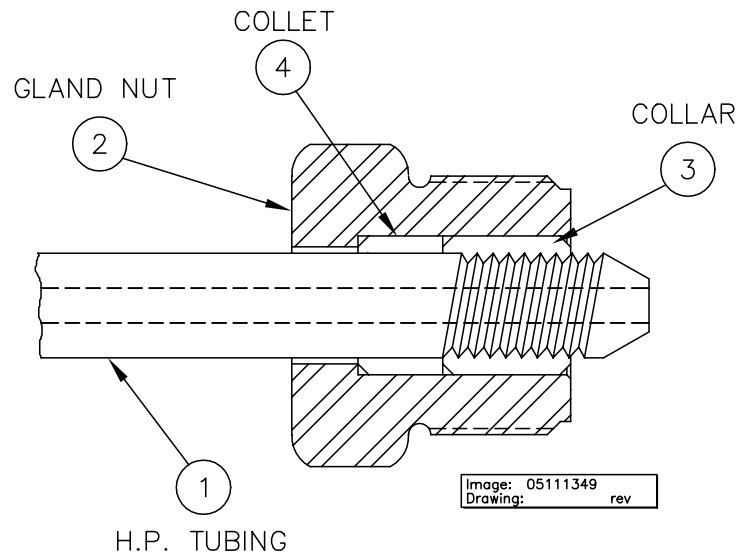

Section 3 OPERATION**3 SL-IV PUMP OPERATION-**

Note: all operational control functions for this KMT Waterjet SL-IV pump are provided by the motion / cutting table / box OEM. For a description of the KMT Waterjet model SL-IV pump sensors and solenoids, see Section 8: 'Electrical Systems'.

This section is devoted to an explanation of the SL-IV+ control logic and operators interaction with it. The SL-IV+ has comprehensive fault detection and troubleshooting logic in the control, and allows operator control of the sensitivity of the overstroke detection in order to optimize the logic for specific operating conditions. The operator functions and warnings programmed in the control of this intensifier offers an unprecedented and comprehensive view of the operating parameters, impending faults, shutdown faults, and suggested remedies. The operator's interface is through a touch sensitive control display on the control console where several menu screens can be selected for various purposes. The screens and their use are explained in this section. The pages following will explain the functions available in the control and how to select and use them.

Following is an explanation of the functions of the control logic, including the start-up sequence.

- The intensifier is equipped with a booster pump output pressure switch. Seven seconds after the intensifier is started, the switch is monitored. If the switch opens, a warning is issued (message and flashing red light). If the condition persists for 30 consecutive seconds, the intensifier is shut down.
- The intensifier is equipped with an inlet cutting water pressure switch. If the switch is not closed, the intensifier will not start and a warning is issued (message and red flashing light). After the intensifier is started, if the switch opens, the same warning is issued. If the condition persists for 20 consecutive seconds, the intensifier is shut down.
- The intensifier is equipped with separate total hour and maintenance hour meters for intensifier one and intensifier two. The operator can reset both maintenance meters. Both total meters can be set to any value via a password protected configuration screen. Without access to this screen, the hour meters can not be reset or changed.
- The Intensifier is equipped with a maintenance function to allow the user to set the plunger in either the left or right position for ease of maintenance.

- Overstroke (**no longer called Leak**) shutdown level is adjustable between 30% and 120% of full capacity. The overstroke warning level is automatically set 10% below the shutdown level set by the operator. Overstroke warnings, pending shutdowns and shutdowns are issued in three types, left, right and intensifier. An intensifier warning or shutdown indicates that the intensifier is shifting too fast in both directions and would point more towards a problem with the orifice or plumbing rather than check valves or seals. If a left or right shutdown occurs, the display tells the operator which parts are suspect. Sometimes, especially if the intensifier is running near full capacity an intensifier shutdown can be displayed when it is actually caused by a left or right fault. This can be diagnosed further by turning the operating pressure down and watching the **Alarms** screen, which displays all alarm occurrences.
 - Real-time running capacity and stroke rate are shown on the display.
 - A resettable stroke counter for both intensifier one and intensifier two are provided on the display.
 - The part numbers for both the PLC and display logic along with the software revision number running on the machine are shown on the Maintenance Screen.
 - The PLC monitors the motor overload relay and displays a message when the overloads trip. The overloads will now be set on automatic reset rather than manual so the enclosure does not have to be opened to reset them.
 - The display will give a message (**motor feedback failure**) if the start relay does not close at start-up or opens due to fault.
 - The start-up sequence will depend on the circumstances.
- (1) **Standard machine-start up after machine has been E-stopped:** Safety dump valve will be open. It will close 3 seconds after the intensifier begins stroking. The pump will be held in low pressure for 20 seconds after motor is started after which pressure will go to high if high is selected, otherwise will stay in low.

The purpose for this is to allow entrapped air to be bled from any HP cylinder that has been maintained to avoid hot air burning the plunger seals.

- (2) **Standard machine-start up after normal stop:** Safety dump valve will be closed, pump will be held in low pressure for 20 seconds after motor is started, after which the pressure will go to high if high is selected, otherwise will stay in low. The purpose for this is to allow entrapped air to be bled from any HP cylinder that has been maintained to avoid hot air burning the plunger seals.

(3) Machine equipped with HP transducer-start up after E-stop:
same as (1) above.

(4) Machine equipped with HP transducer-start up after normal stop: If pressure is allowed to bleed through orifice to below 1,000 psi, dump valve will open and start up will be like (1) above, if pressure is not allowed to bleed, start up will be as (2) above.

- The display screen will always default to the **Run** screen after being on any other screen more than 5 minutes.
- If the intensifier is equipped with a HP transducer, the displayed pressure can be shown in psi or Bar. Recalibration of the transducer is automatic and does not require operator input.
- If the intensifier is equipped with an hp transducer, another level of overstroke protection is obtained by shutting down at the warning level if the pressure is less than 3,000 psi.
- The display saves the last 100 alarm shutdown messages, which can be viewed with times, dates and message contents.

MAIN MENU Scroll up and down to page through the various screens and press **ENTER** to select desired screen

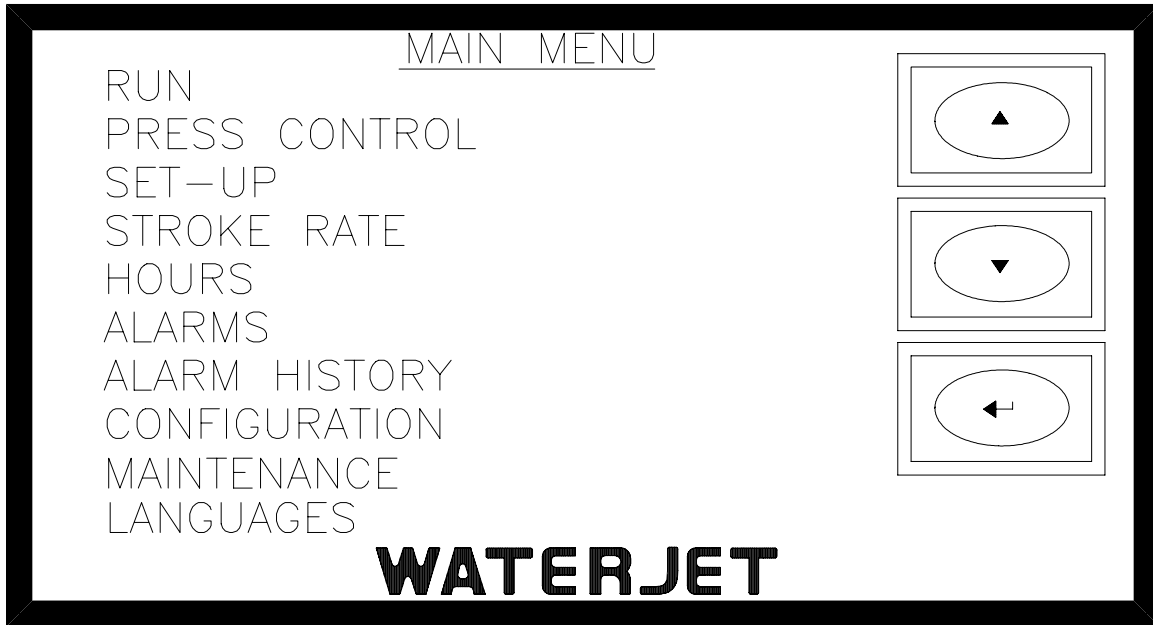

Run Screens -(4) Start, stop, recirc, recirc time, select high or low pressure, select intensifier if redundant. Run Screens appear according to options.

Pressure Control Screens - (2) Increment or decrement pressure setting. Display machine pressure. These screens will appear only on machines equipped with analog pressure control.

Set-up Screens -(2) Water reset function, idle shutdown time. Transducer and Proportional Pressure Select, Redundant select. Screen configures display for a particular machine. Analog Also contains PSI/BAR select button .

Stroke Rate Screens (2) - Set and observe machine stroke rate, stroke count.

Hours Screen- (2)Displays total operating hours and re-settable maintenance hours.

Alarm Screen - Displays all alarm conditions.

Alarm History Screen - Displays time and date of shutdown alarms and keeps history up to 100 past alarms.

Configuration Screen - Secure screen used by manufacturer to change certain display settings.

Maintenance Screen - Stop, start recirc, jog left, jog right for maintenance.

Language Screen - Select five languages

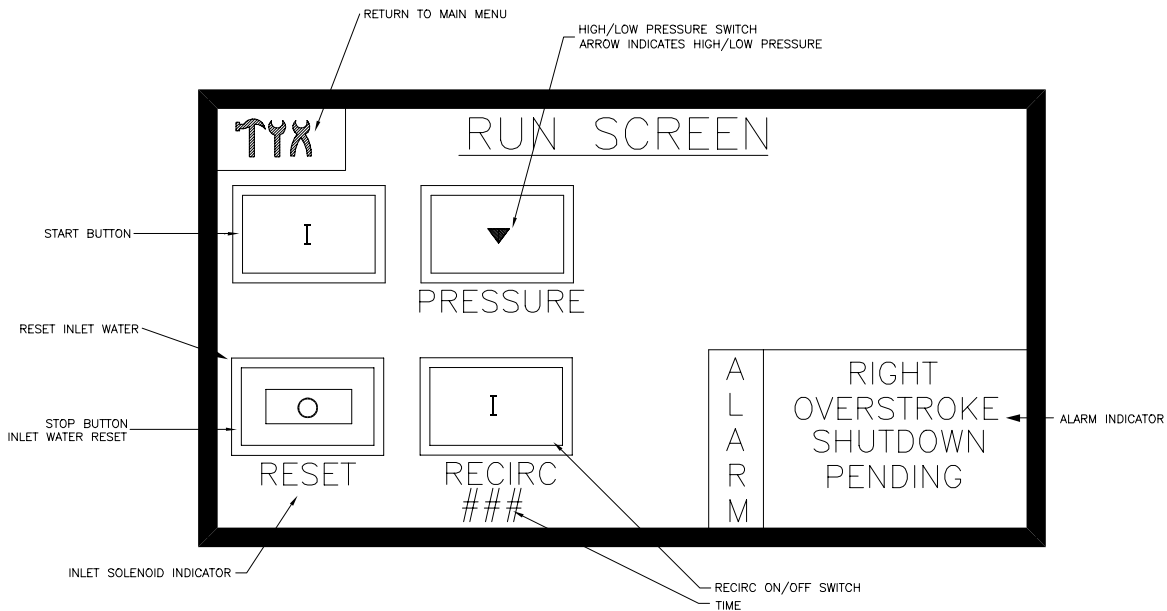

RUN SCREEN

THIS IS THE ONLY SCREEN WITH A MACHINE START FUNCTION

- I** **START** On all screens this indicates **start** or **on**.
- O** **STOP** On all screens this indicates stop or off.
- Pressure** When equipped with pressure transducer (Run Screen 2).
- ALARM** In alarm state, the **last** alarm sensed by machine will be displayed. Multiple alarms can be displayed on the alarm screen.
Select intensifier 1 or 2 if equipped.
On power-up display will default to this screen.
After 5 minutes on any screen, display will return to Run Screen.
- Recirc** Select this to toggle the recirculation mode on or off. The recirc mode runs the machine without generating high pressure, and is used to circulate the hydraulic oil through the heat exchanger to cool the oil following a high temperature shutdown.
 - (I)** Indicates recirc on
 - (O)** Indicates recirc is off.
- Stop** Stop Recirc with this button.
- High-Low Pressure Switch** Select high or low water pressure. (Machine always starts in low pressure.) Arrow indicates selected pressure following machine startup delay expiration.
- RESET** Indicates inlet water function must be reset. Reset by pressing **STOP** button.

Run Screen ALARMS

1. **High Oil temperature** – Indicates high hydraulic oil temperature-150° F.
2. **High Pressure Warning** – Indicates that output pressure is above 64,000 psi or 4,413 BAR.
3. **Booster Temperature High** – Indicates booster pump water temperature is high and machine shutdown is pending-128° F.
4. **Low Booster Pressure** – Indicates that booster pump output pressure is inadequate for proper machine operation and shutdown is pending, less than 60psi.
5. **Low Inlet Water Pressure** – indicates that cutting supply water pressure is inadequate to permit proper machine operation and shutdown is pending, less than 30psi.
6. **Bleed High Pressure Lines** – Indicates that the intensifier is shut down and that high pressure is present in the discharge plumbing of the intensifier that should be bled off to avoid the possibility of injury.
7. **Left/Right/Intensifier Overstroke Warning and Shutdown Pending** – Indicates an abnormally high stroke rate caused by an external or internal leak. If the condition persists, the machine will be shut down with an Overstroke Shutdown alarm.
8. **Reset Inlet Water** - Indicates inlet water must be reset. RESET will flash and can be reset by pressing stop button

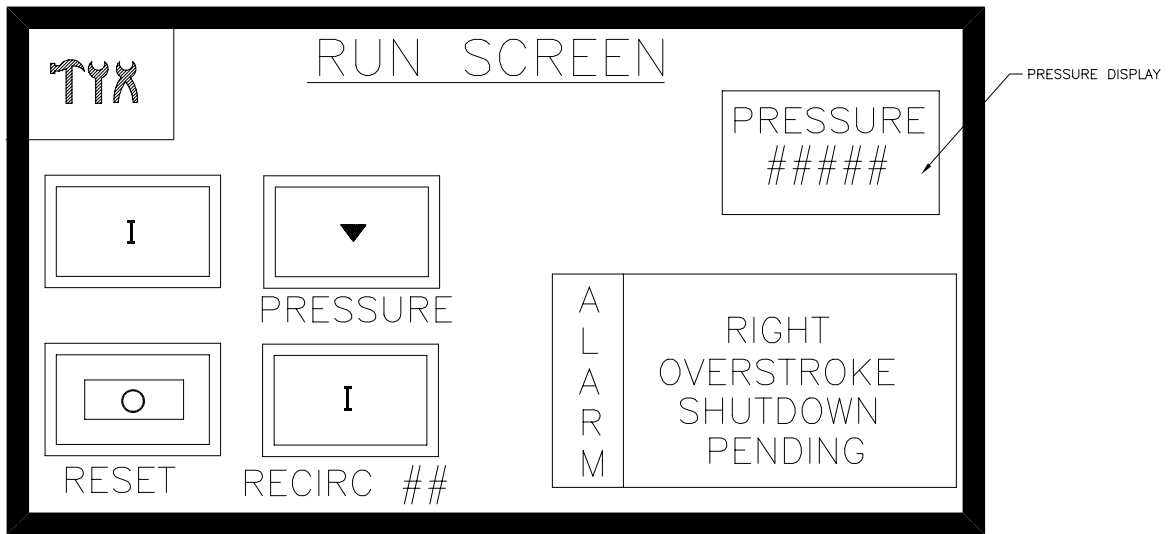

RUN SCREEN 2

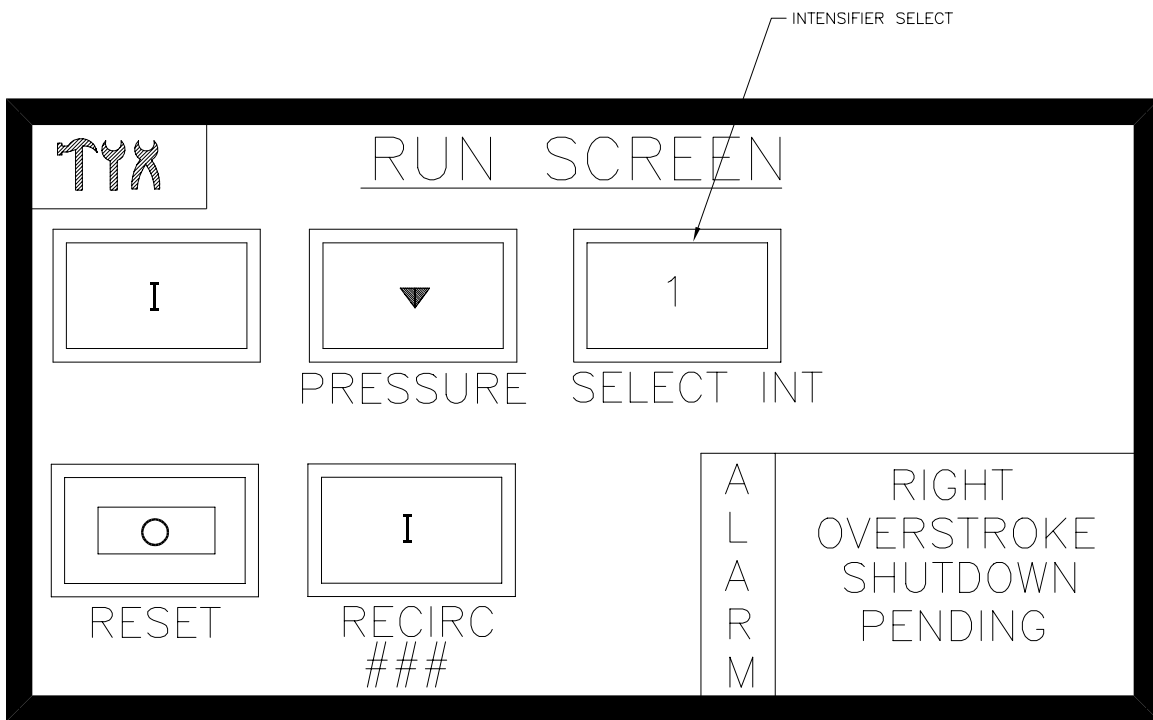

RUN SCREEN 3 (REDUNDANT)

This screen will be displayed if **REDUNDANT** button on the **SETUP** screen is **ON**. **SELECT INT** button is used to select intensifier one or two

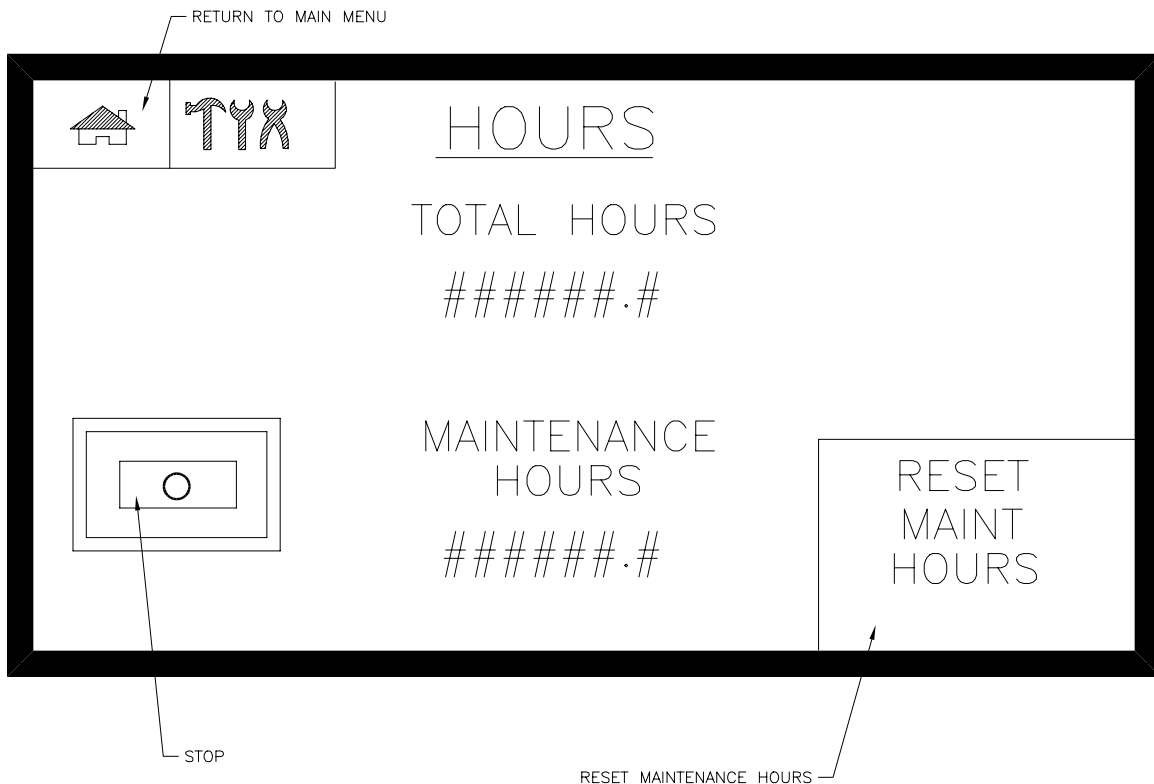

HOURS

Machine can be Stopped from this screen.

HOURS This screen displays total machine hours and resettable maintenance hours to 9,999,999 for intensifiers 1 and 2.

TOTAL HOURS cannot be reset.

MAINTENANCE HOURS on intensifiers 1 and 2 can be reset by pressing the RESET MAINT HOURS display button.



(EXAMPLE)

ALARM HISTORY SCREEN

The alarm list stores the last 100 triggered alarms indicating date, time and type of alarm.

Scroll up and down to see alarm history.

The Alarm History Screen does not have an intensifier **STOP** function.

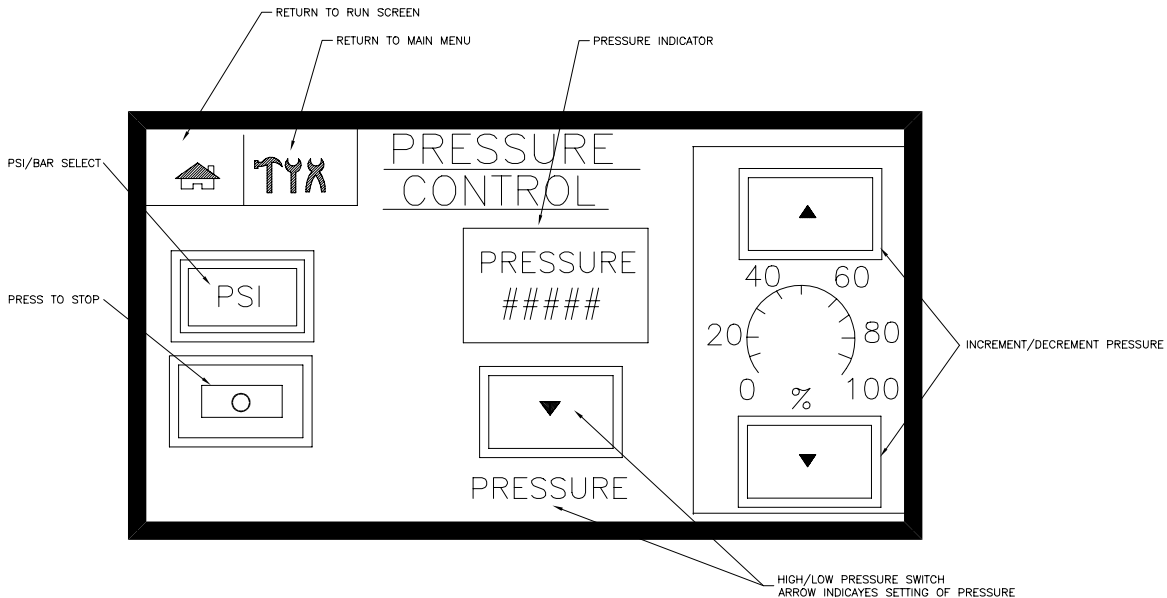

PRESSURE CONTROL SCREEN

SET PRESSURE Set pressure to desired setting from 0 to 100 % in 1 % increments. UP arrow to increase pressure, DOWN arrow to decrease pressure.

PRESSURE CONTROL SCREENS will not appear if analog module (pressure transducer and/or proportional valve) is not installed on the machine. If pressure control on main menu is selected and a proportional valve is not installed, a screen will appear indicating **“THIS UNIT IS NOT EQUIPPED WITH PROPORTIONAL CONTROL”**.

The **PRESSURE CONTROL SCREEN** that is required can be selected on the **SET-UP SCREEN** for the appropriate pressure control, used if a proportional valve, a pressure transducer, or both are used on machine. These are the **TRANSDUCER SELECT** and **PROPORTIONAL SELECT** buttons on the **SET-UP SCREEN**.

HIGH/LOW pressure switch and **UP/DOWN** arrow indicating high or low pressure also on this screen. The same function is on the **RUN** screen.

Machine **PRESSURE** is also indicated on this screen in either PSI or BAR. Can be changed on **PSI/BAR SELECT** button. This function is only found on machines with a transducer installed.

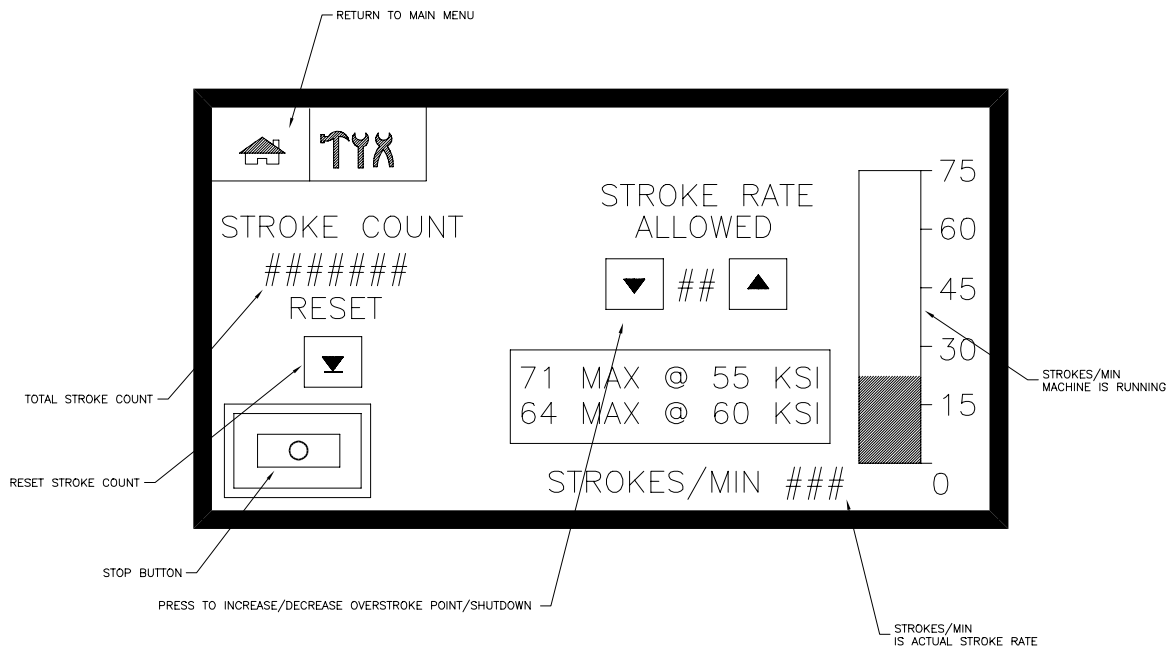

STROKE RATE SCREEN

Set STROKE RATE 2 to 4 strokes above normal running rate to shutdown machine in case of overstroke condition.

RESET Press to reset intensifier stroke count.

STROKES/MIN is actual stroke rate.

The **bar graph** illustrates strokes/minute.

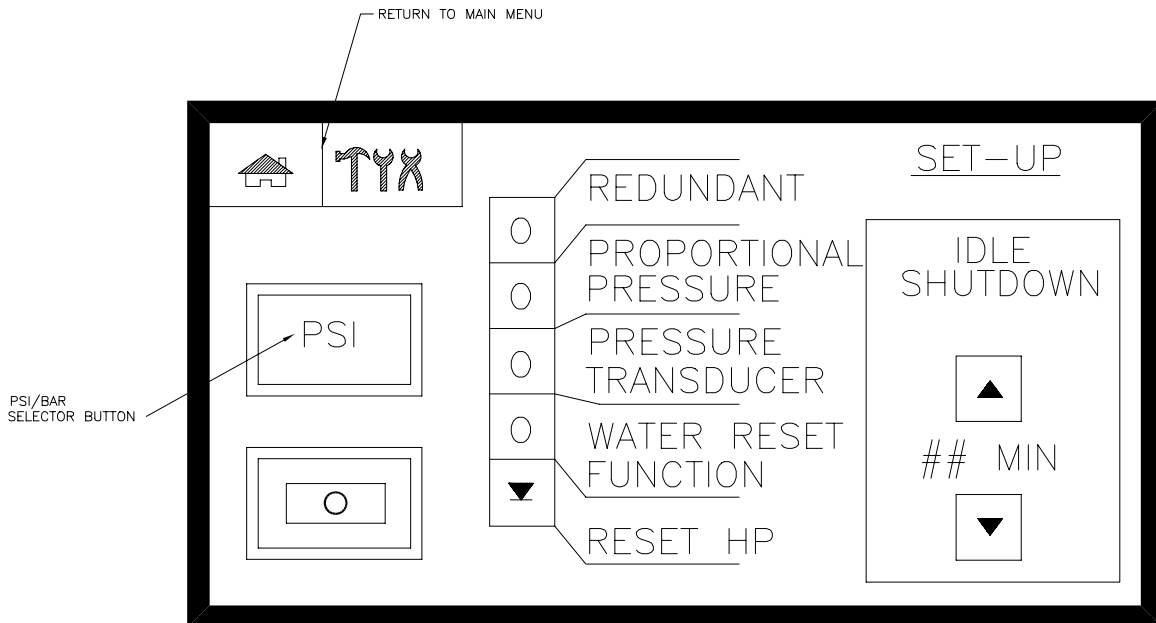

SET-UP SCREEN (2)

This screen will be displayed if analog control present.
 Select if Proportional Pressure, Pressure Transducer, or both are in unit.
PSI/BAR selector button changes pressure display on **RUN** screen and **PRESSURE CONTROL** screen

There are two **SET-UP SCREENS** – If analog pressure control is not installed on the machine, a screen will appear that does not include the **TRANSDUCER** and **PROPORTIONAL SELECT** buttons. These buttons are used only if a pressure transducer and/or a proportional valve are installed on the machine

WATER RESET FUNCTION

Press on **(I)** to shut water off five (5) minutes after machine shuts down. Selecting this function will insure that the inlet cutting water is shut off following a shutdown fault. This can prevent water from leaking past a damaged water seal following an overstroke shutdown caused by a seal failure.

IDLE SHUTDOWN TIMER

To set idle shutdown time press up/down arrows from 5-30 minute increments. This feature saves energy by automatically shutting down the intensifier if it is not being used.

Redundant-press on **(I)** if two topworks are present. This function changes screens to indicate two topworks are present.

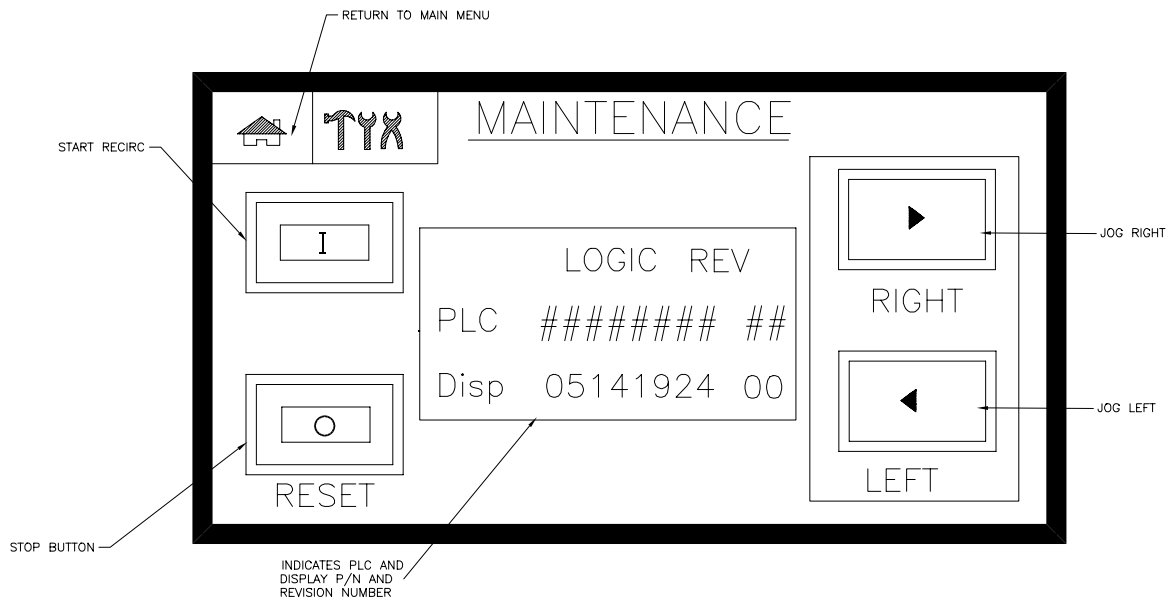

MAINTENANCE SCREEN

Start button will start unit in RECIRC mode and will open dump valve. STOP button will stop unit. Jog right will extend piston to the right giving full exposure to the right plunger once the unit is disassembled. Jog left will do the same to the left plunger.

CAUTION: Unit must be completely assembled to use Jog functions.

PLC and display part and revision numbers are displayed on this screen to indicate programs installed.

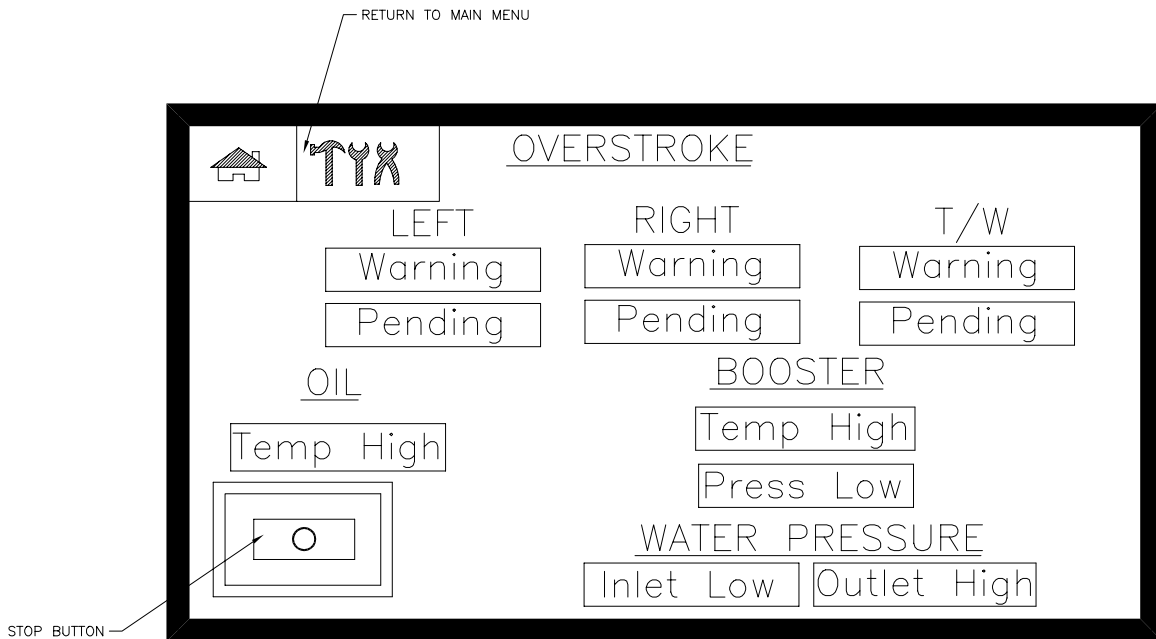

ALARM SCREEN

In **ALARM** condition, Message/Alarm, will flash. Messages are not visible if an alarm condition does not exist. All alarm conditions are visible on this screen and on **START** screen.

OIL Indicates high oil temperature. High oil temperature will shut the machine off 60 seconds after detection of this alarm condition.

Low oil level (not on this screen) will immediately shut the machine off. This alarm will appear on the **ALARM BANNER**.

BOOSTER PRESS LOW Alarm indicates low booster pump output pressure. Low booster pressure will shut down the machine 40 seconds after alarm condition is detected.

HIGH BOOSTER TEMPERATURE Alarm indicates high booster pump temperature. The machine will shut down 30 seconds after this alarm condition is detected.

PRESSURE INLET LOW alarm indicates low booster outlet water pressure. The machine will be shut off if the condition persists for 30 seconds.

OUTLET HIGH alarm indicates excessively high discharge water pressure. This alarm is available only if a pressure transducer is installed on the machine.

OVERSTROKE Alarms indicate overstroke conditions. First a **WARNING**, then a **PENDING SHUTDOWN** alarm will occur. If condition persists the machine will SHUTDOWN due to overstroke. This shutdown condition is indicated on the **ALARM BANNER**.

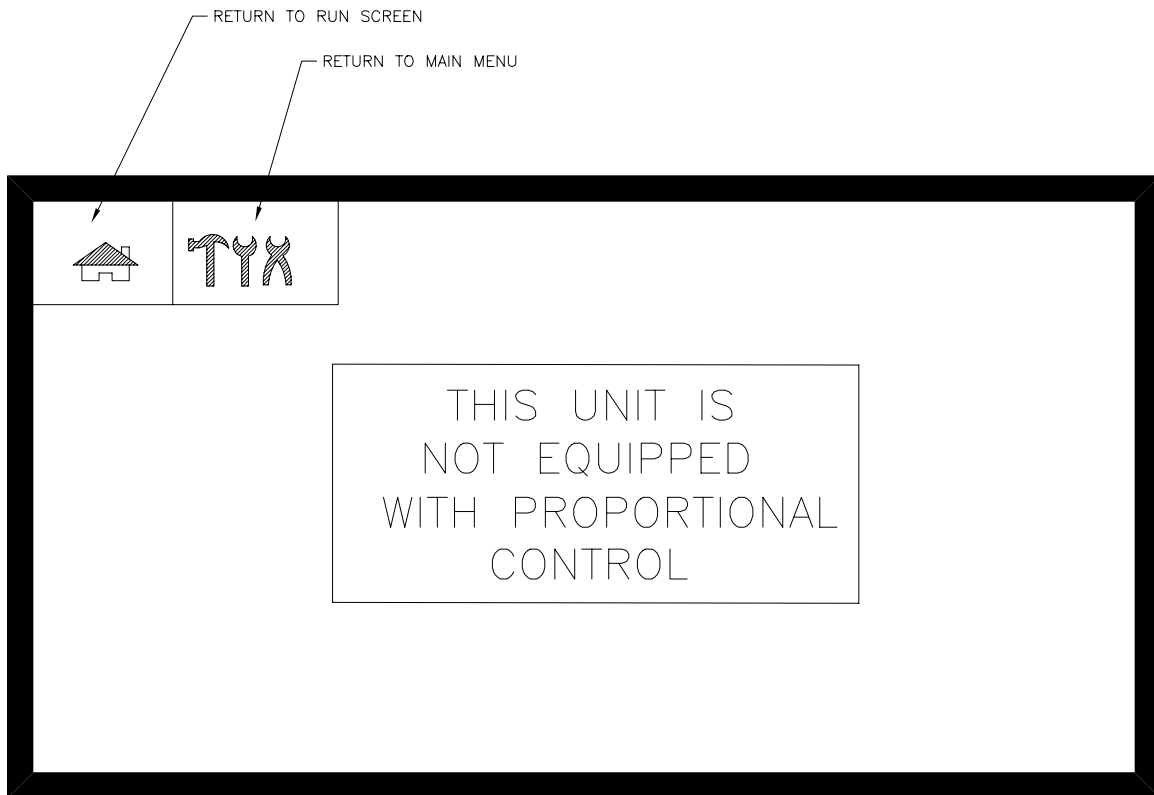

NO PRESSURE CONTROL

This screen will appear if the pressure control on main menu is selected and machine does not have PROPORTIONAL control.
The machine cannot be stopped from this screen.

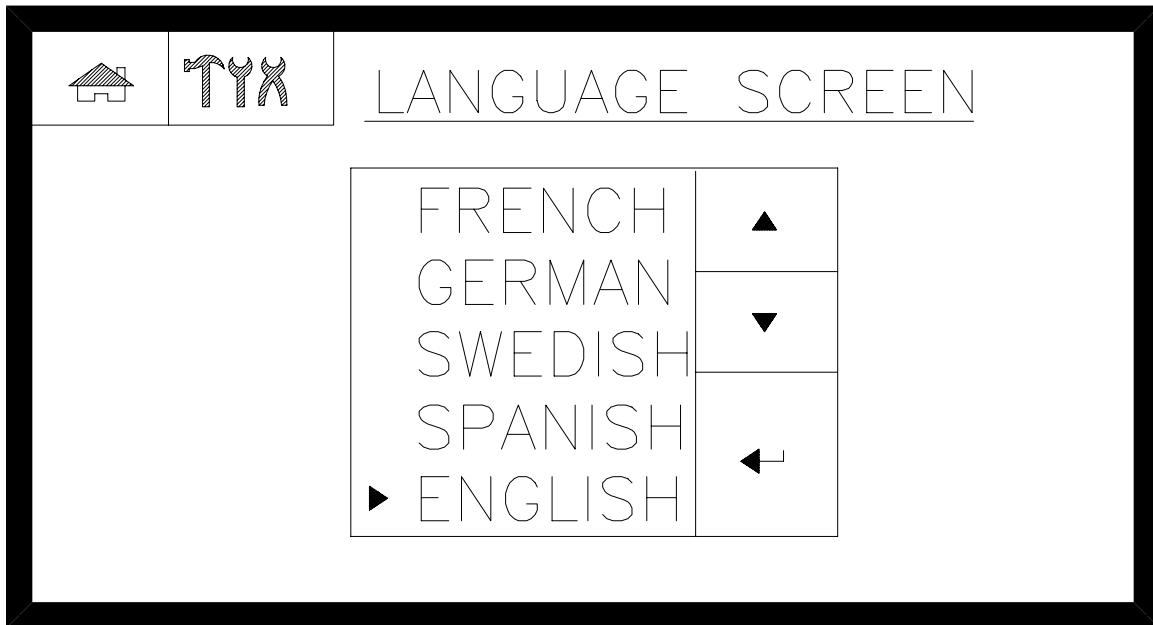

LANGUAGE

Scroll up and down for desired language and press **ENTER** to select FRENCH, GERMAN, ITALIAN, SWEDISH, or ENGLISH.

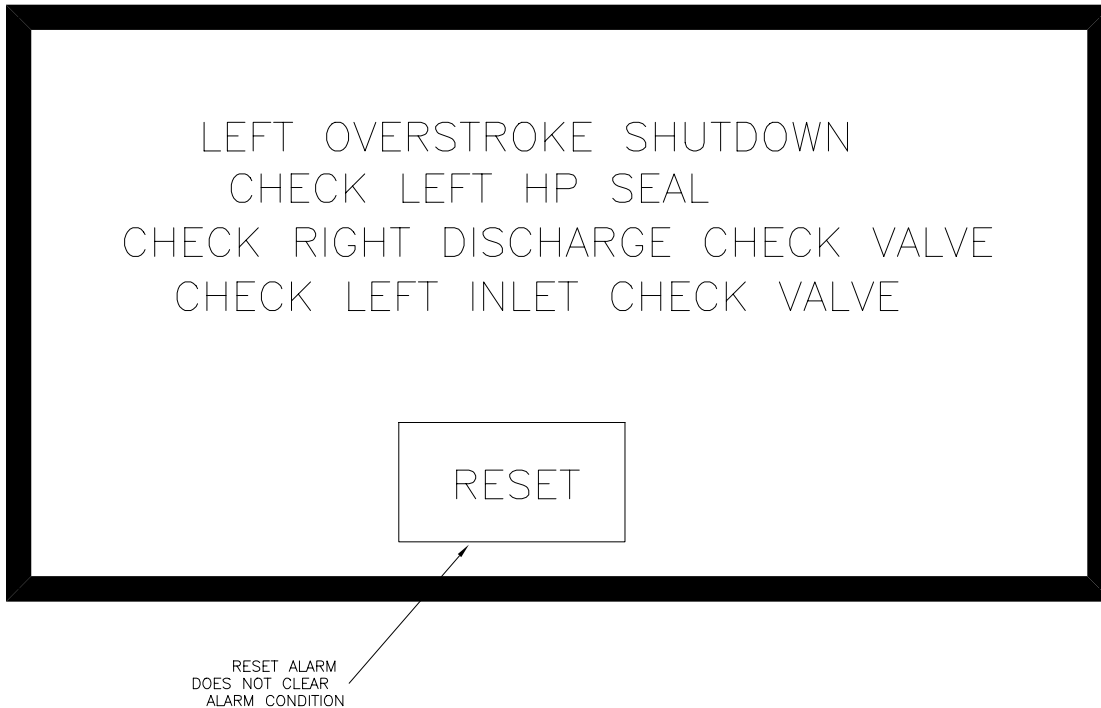

**ALARM BANNER
(EXAMPLE)**

When a shut-down condition occurs, an ALARM BANNER will appear hiding the current screen. The ALARM BANNER will display the type of shutdown and remedy to clear the alarm.

Pressing the reset button will clear the ALARM BANNER but does not clear the alarm. The banner will continue to appear until the alarm condition is cleared. Shutdowns will appear on ALARM HISTORY SCREEN.

The ALARM BANNER shutdowns are:

- Motor Overload – check incoming voltage, check overload relay setting.
- Motor Feedback Failure – Check motor starter relay.
- Oil Level Low – Check the oil level gauge on the reservoir, check for leaks.
- Oil Temp High – Check cooling water flow with a flow meter.
- Low Booster Pressure – Check the booster pressure adjustment and check booster condition
- Low Inlet Water Pressure - Check water supply pressure at maximum flow rate.
- Long Idle Time Shutdown – May be selected for energy saving.
- Overstroke Shutdown – Check plumbing for leaks, check HP orifice, check for leaking HP check valves.
- Booster Temp High – Check incoming water temperature, check for long idle time.
- Left Overstroke Shutdown - Check left high-pressure seal, check right discharge check valve and check left inlet check valve.
- Right Overstroke Shutdown - Check right high-pressure seal, check left discharge check valve and check right inlet check valve.
- T/W Overstroke Shutdown – Check plumbing for leaks, check for long idle time.

Section 4 MAINTENANCE**4 Maintenance**

This section provides an overview of “Scheduled Maintenance” and “Preventive Maintenance”. In addition, maintenance of the five systems is necessary and is described in their respective sections. Refer to the following sections for detailed information on the operator console and systems maintenance:

- Operator Console, Section 3
- Low Pressure Water, Section 6
- High Pressure Water, Section 7
- Electrical System, Section 8
- Hydraulic System, Section 9
- Recirculation System, Section 10

The following is an overview of the primary components and their location.

- **Hydraulic Pump** – including electric motor, and hydraulic valve manifold block. The pump is a variable displacement, axial piston and pressure compensated type.
- **Recirculation Pump** – including a fixed displacement gear – type pump, oil to water heat exchanger, hydraulic return line – type filter, and related hydraulic hoses and fittings. The gear pump mounts to the back of the variable piston pump, which has a through shaft.
- **Booster Pump** – includes a stainless steel vane – type pump with pressure adjustment and high temperature switch, low pressure water filter, bypass relief valve, and associated water tubing and fittings. The booster pump is mounted to the back of the hydraulic gear pump, which has a through shaft.
- **Intensifier Assembly** – includes one or two high pressure (HP) attenuators, one or two hydraulic intensifier assemblies, a HP dump valve and associated HP piping with fittings.

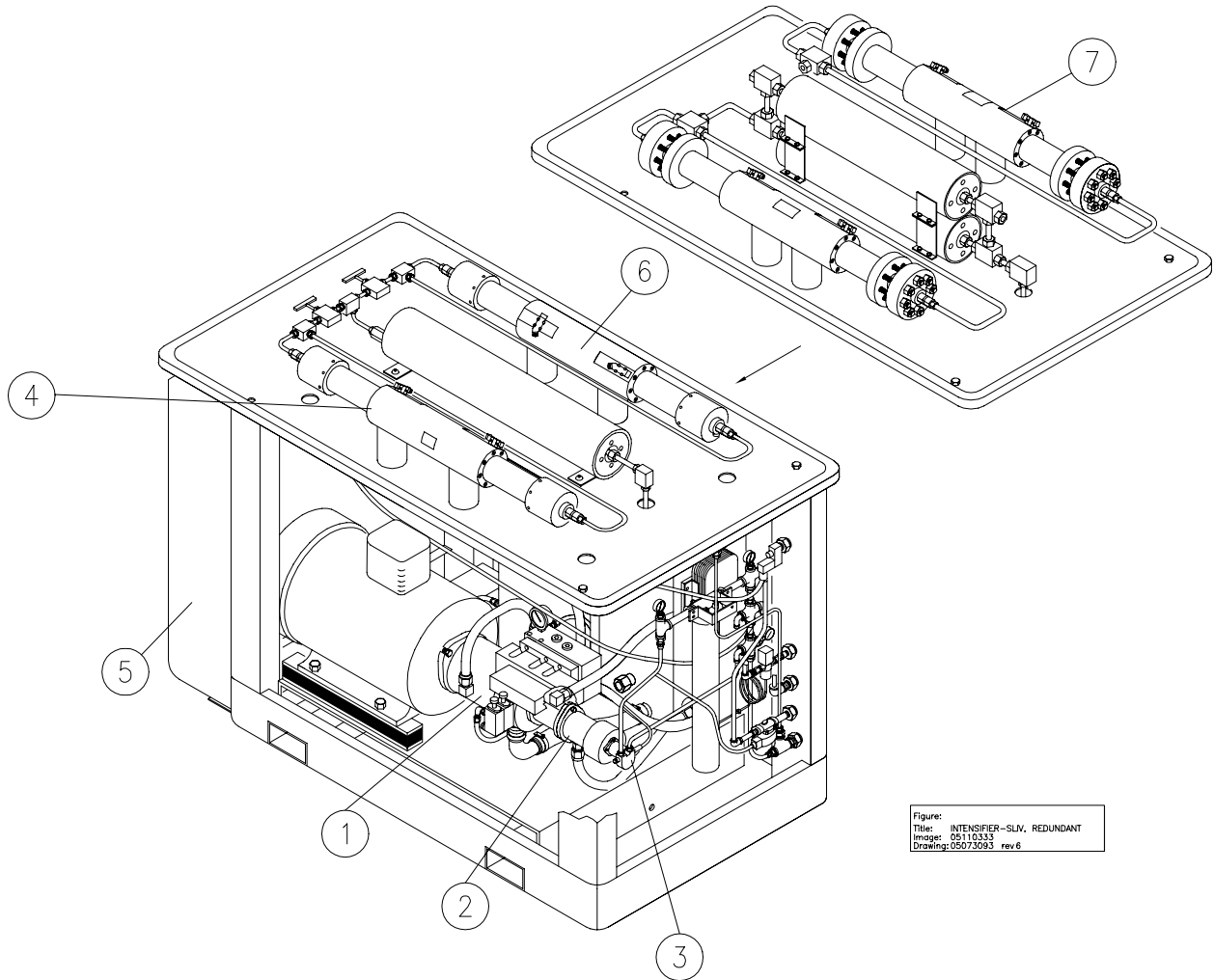

Figure:
Title: INTENSIFIER-SLV, REDUNDANT
Image: 05110333
Drawing: 05072081 rev 6

Item Description

- | | | |
|--|---|------------------|
| (1) Hydraulic Pump | (2) Recirculation Pump | (3) Booster Pump |
| (4) Intensifier Assembly | (5) Control Panel | |
| (6) Intensifier Ass'y Redundant-Option | (7) End Closure Detail (Plus Intensifier)
(T-series) | |

4.1 Scheduled Maintenance

Check Description	Item to be Checked	Major Component	As Req'd	Per Shift	Weekly	Monthly	3-Month	6-Month	Yearly ¹	Other
Fluid Level & Leak Checks	Oil Level	Hydraulic Oil Tank		X					R	
	Oil Sample	Hydraulic System				F				
	Hydraulic Cartridge Seals	Hydraulic Cylinder	X	X						
	Plunger Seals	HP Cylinder	X	X						
	Sealing Head	HP Cylinder	X	X						
Pressure & Flow Checks	Water Supply Pressure	Low Pressure Filter Assembly	X	X						
	Intensifier Discharge Pressure	HP Piping	X							
	Hydraulic Pump Pressure	Hydraulic Pump		X						
Temperature Checks	Plunger Seal	HP Cylinder	X	X						
	HP Check Valve	Port Sealing Head	X	X						
	Cooling Water Inlet/Outlet	Oil/Water Heat Exchanger	X			F				
Lubrication & Filter Checks	Motor Bearings Lube	Hydraulic Power Unit	X					R		
	Hydraulic Filter	Hydraulic Oil Tank	X	X				R		
Vibrations-Rotating Equip.	Electric Motor					F			L	
	Hydraulic Pump					F				
Splined Shaft Service	Motor/Pump Connection	Motor-Female Spline Piston Pump-Male Spline							L₂	
System Cleaning & Inspections	Hydraulic Pump					F				
	HP Tubing, Valves, & Fittings					F				
	Hydraulic Manifolds	Hydraulic Intensifier				F				
	Control Panel	Electrical Enclosure				F				
	Gage Calibration	Hydraulic Pump & HP Piping				F				
Control Lights			X							
Hydraulic Piston	Seal & Wear Rings	Intensifier Hydraulic Cylinder								R₃

Key:

- F:** Information
- X:** To be observed
- R:** To be replaced
- L:** To be lubricated

¹Yearly or 4,000 hours, whichever comes first.

²See Section 9.3.3 concerning spline lubrication recommendations.

³Recommended Overhaul Interval: 10,000 hours

4.2 General Maintenance

Proper maintenance is important for reliable and consistent performance. Preventive maintenance reduces unscheduled downtime, and extends component life.



High pressure water will cut almost anything it contacts. Any leaks must be repaired immediately to prevent damage or serious personal injury.



Stored hydraulic pressure can cause physical injury. Should the unit be configured as a redundant intensifier, before performing maintenance, all isolation hand valves should be cycled after machine shutdown to vent to tank any stored hydraulic pressure.

Maintenance Guidelines

- Regular inspection of equipment is recommended.
- Keep equipment and surrounding areas clean.
- Check pressures, temperatures, and look for leaks.
- Make repairs immediately.
- A maintenance record should be kept.

Work Area

- Maintain a clean work area for repair and maintenance of the waterjet pump.
- Use a clean work bench in a dust and dirt free work area.
- Use lint-free material for wipe cloths.
- When blowing off parts with compressed air, use only clean, dry air. When flushing parts with a solvent, use only clean, filtered fluid.
- Always use original Ingersoll-Rand replacement parts, for consistent performance, reliability, safety, and to protect equipment warranty.

Safety Recommendations

- Carefully read the Safety Guidelines in Section 1, of this manual.
- Lock out all electrical power.
- Close all incoming supply valves and open all drain valves.
- Close the nozzle valves and manifold valves. When the power is shut off, the safety dump valve will open and bleed off high pressure water stored in the discharge piping.
- Provide suitable receptacles, pans, trays, etc. to catch and retain fluids to avoid a hazardous work area.
- DOUBLE CHECK to insure that all pressure is relieved from the system before proceeding.

Binding and Interference

When assembling close tolerance machine parts, use extreme care in aligning them for assembly. Do not force the parts together. If parts bind during assembly, separate them and try again until they are successfully mated.

NOTE

It should never be necessary to force an assembly together.

Plunger material is strong, but brittle. Avoid dropping, sharp blows, or heavy bending loads when working with these expensive parts.

Make sure all parts are clean, free of burrs, metal particles, dirt, dust, etc. Use High Purity Goop (Part 10084440), when assembling any high pressure fitting.

After servicing any high pressure components, flush the high pressure water system by operating the waterjet pump for a short period with the nozzle valve open and no orifice in place. Next, shut down the waterjet pump, install an orifice, and slowly increase the discharge water pressure in stages. Check all high pressure connections for leaks.

Unusual requirements should be referred to the Technical Services group at Ingersoll-Rand.

To contact the KMT Waterjet Spare Parts Department:

USA: Parts Department
KMT Waterjet Systems
635 West 12th Street
Baxter Springs, KS 66713 USA
Phone: (620)856-2151
Fax: (620)856-5050

Europe: Spare Parts Manager
KMT Waterjet Systems GmbH
Wasserstrahl-Schneidetechnik
Auf der Laukert 11
D-61231 Bad Nauheim Germany
Phone: 49-(0)6032-997-115
Fax: 49-(0)6032-997-271

Section 5 TROUBLESHOOTING**5.1 TROUBLESHOOTING - ELECTRICAL****5.1.1 Pump Will Not Start**

E-STOP Button Depressed	Pull out E-STOP button. Check all remote E-STOP pushbuttons. Push CONTROL POWER ON button – white light on CONTROL POWER ON button should illuminate.
Power Disconnected	Check that main power is present. Check that main power disconnect is ON.
Control Power Interrupted	Check power supply circuit protection (tripped breaker). Check power supply (24vdc) input and output.
Protection Fault Activated	Check LOW OIL LEVEL , HIGH OIL TEMPERATURE , OVERSTROKE CONDITION , or HIGH TEMPERATURE BOOSTER PUMP (bold letters indicate display messages)
Motor Overload Relay Tripped	Find reason for overload. Reset overload relay.
Inlet Water Valve Turned Off	Reset water valve by pressing RESET on Run menu.

5.1.2 Console Display and Lights Fail to Illuminate

E-STOP Button Depressed	Pull out E-STOP button. Check all remote E-STOP pushbuttons. Push CONTROL POWER ON button - white light on CONTROL POWER ON button should illuminate.
Main Power Disconnected	Check main power.
Door Unlatched (locked out)	Check that the door disconnect switch is properly engaged.
Control Power Not Available	Check power supply circuit protection (tripped breaker). Check power supply (24vdc) input and output.

5.1.3 Pump Quit Running

Unsafe Operation Detected	Check fault indication on operator's console and correct: LOW OIL LEVEL , HIGH OIL TEMPERATURE , OVERSTROKE CONDITION , or HIGH TEMPERATURE BOOSTER PUMP .
Electrical Power Interruption	Check power supply circuit protection (tripped breaker). Check power supply (24vdc) input and output. Check that main power is available.
Motor Overload Relay Tripped	Find reason for overload. Reset overload relay.

5.1.4 No Control Power (24vdc)

Circuit Breaker Tripped	Check input circuit breaker of power supply. Check output circuit breaker (24vdc) of power supply.
Power Supply Fault	Check power supply input and output voltages.
E-stop Button Depressed	Pull out E-stop button. Check all remote E-stop pushbuttons
Control Power On Button	Check for voltage through switch when button is pushed.
MCR Relay Not Energized	Check to see if coil is pulling in on the master control relay (MCR)
MCR Contact Set Failure	Check to see if contact sets on MCR are changing state when MCR is energized.

5.1.5 Red Light, Message On Operator's Console

Left Overstroke	Check left HP seal Check right discharge check valve Check left inlet check valve
Right Overstroke	Check right HP seal Check left discharge check valve Check right inlet check valve
T/W Overstroke	Check plumbing for leaks Check HP orifice Check HP dump valve
Booster Pump Pressure	Check booster adjustment Check booster condition
Inlet Water Pressure	Check water supply Check water filter
Oil Temp	Verify hydraulic oil tank temperature is above 62°C (144°F). Check output pressure of oil recirculation pump. Check cooling water flow to heat exchanger. Adjust water modulating valve.
Oil Level	Check hydraulic oil level on the reservoir sight glass. Check for and correct hydraulic oil leak, add oil to tank. If reservoir is full, check oil level switch.
Booster Pump Hot	Check if booster pump temperature is above 53°C (128°F). Check cutting water flow to/from booster pump. Check water bypass orifice. Check excessive time in deadheaded condition. Check booster pump temperature switch.

5.2 TROUBLESHOOTING – HP WATER**5.2.1 HP Water Signal Abnormal Fluctuation**

Orifice Large/ Worn/ Damaged	Check that orifices in use do not exceed capacity of pump. Check that orifices are in good working order. Verify that a jewel is not missing from the orifice mount.
Check Piping Leaks	Check system components for leaks including dump valve condition.
Check Valve Leakage	Inspect pump discharge HP check valves. Inspect pump inlet low-pressure (LP) check valves.
Check Seal Leakage	Inspect plunger seals and sealing heads.
Hydraulic Control Malfunction	Check hydraulic valve operation. Verify proper shifting of 4-way directional control valve. Verify proper proximity switch operation.

5.2.2 Hot Surfaces On HP Cylinder Components

HP Discharge Check Leaking	Inspect check valve seat, poppet, spring, and spring guide condition and sealing head.
LP Inlet Check Valve Leaking	Inspect check valve poppet, spring, o-ring, poppet retaining screw, and sealing head.
Sealing Head or Plunger	Check plunger and sealing head for erosion scratches or mechanical damage and replace if necessary.
Damaged HP Cylinder	Check cylinder bore for damage. Polish if required.

5.2.3 Oil or Water Leaks from HP Cylinder Weep Holes

Oil Leak HP Intensifier	Check hydraulic cylinder O-ring and back-up ring for leakage. Check proximity switch and spacer O-ring area for oil leakage. Replace hydraulic seal (cartridge) and clean holes in hydraulic seal retaining flange.
-------------------------	---

Water Leak at HP Plunger Seal	<p>Replace seal assembly if leak exceeds one drop in 10 strokes.</p> <p>Check plunger surface and cylinder bore for build-up of seal material and polish off with 600 emery cloth, polishing the cylinder circumferential and plunger any direction</p> <p>Check Plunger surface and cylinder bore for scratches circumferential and longitudinal, if any are found, contact IR for possible rework and polishing.</p> <p>Check plunger for dull finish, contact IR for polishing.</p>
Water Leak at Sealing Head	<p>Check torque of sealing head screws.</p> <p>Check for scratches on inside diameter of HP cylinder. Polish if required with 600 emery cloth.</p> <p>Check for scratches in area of sealing head seal. Polish if required with 600 emery cloth.</p>

5.2.4 HP Check Valve Leak

If there are no visible HP water leaks, but there are higher temperatures on HP cylinder or sealing head, this indicates a HP or LP check valve leak. Use corrective action listed in **5.5** for both discharge and inlet checks:

5.2.5 Normal Temperature, but Check Valve Problem

Follow the instructions for HP check valve leak described in **5.5**.

5.2.6 HP Cutting Water Too Low

Low Hydraulic Pressure Setting	If in LO, turn pressure switch to HI. Check hydraulic pump pressure setting.
HP Water Filter Clogged	Clean or replace filter.
Worn HP Orifice	Replace orifice.

5.3 TROUBLESHOOTING – LP WATER

5.3.1 Low Booster Pump Pressure

Booster pump pressure below 60 psi	<p>If at anytime the pump is running and the booster pump pressure falls below 60 psi, adjust the relief valve clockwise to increase the pressure above 60 psi.</p> <p>If the booster pump pressure cannot be adjusted above 60 psi, replace the booster pump.</p>
------------------------------------	--

Booster pump pressure above 125 psi If at anytime the pump is running and the booster pump pressure is above 125 psi, the relief valve is opening up and sending water to the drain.

5.4 TROUBLESHOOTING – HYDRAULIC

5.4.1 Hot Hydraulic Oil

Restricted or No Cooling Flow Check cooling water flow to and from heat exchanger.
The water pressure differential across the heat exchanger, 2.75 bar (40 psi) minimum required for flow through the exchanger.
Check operation and setting of water modulating valve.

Water Modulating Valve Setting Check and adjust setting of water modulating valve.
Compressing spring (clockwise) slows water flow and increases temp; reducing spring tension (counterclockwise) increases water flow and lowers oil temp.

Heat Exchanger Clogged Flush heat exchanger, improve flow of cooling water or replace heat exchanger.

Recirculation Pump Hydraulic Pressure below 20psi Replace hydraulic oil filter.
If filter is new, replace recirculation pump.

5.4.2 Hydraulic Pressure but no High Pressure Water Pressure

Proximity switch failure Verify left hand and right hand LED lights on DC alternately illuminate ON/OFF. If so, both proximity switches are properly functioning.
If both the green and red LED lights are on at the same time on one proximity switch, replace the proximity switch.
Flag the proximity switches one at a time, checking to see if it is sending a signal to the PLC.

I/O relay failure Check if PLC output is shifting the I/O output relays and allowing power to go to the coils on the directional valve.

Directional valve coil failure Check coils on the directional valve with a volt meter to verify good or bad

PLC failure If there are inputs from the proximity switches but no outputs, contact IR service for a logic review and verification of PLC failure.

5.5 SPECIAL PROCEDURE—HP WATER CHECK VALVE TROUBLESHOOTING**5.5.1 HP Check Valve Troubleshooting**

A leaking HP check valve is suspected if either HP cylinder or sealing head is unusually hot. Compare temperatures of opposing sealing heads or HP cylinders to decide location of hot spot. Note any heat in LP water.

The display will tell you which direction is pumping faster. If the leak is bad enough, the intensifier will shut down and the display will tell you where to look for the problem. For instance, if the display indicates a Left Stroke Warning or Shutdown, the probable problem is either at Left Inlet Valve or Right Discharge Valve. You can usually confirm which it is by feeling heat on one side or another.

NOTE: The bolted flange / metal-to-metal seal arrangement of the SL-IV Plus sealing head make the INLET check valves much more difficult to access for maintenance than the HP OUTLET check valves. Therefore one should generally rule out problems with the OUTLET HP check valves prior to disassembling the INLET check valves.

Section 6 LOW PRESSURE WATER SYSTEM**6 Low Pressure Water System**

The SL-IV Waterjet Pump is equipped with two low pressure circuits:

- Cutting water supply for HP intensifier assembly.
- Cooling water supply for the oil-to-water heat exchanger.

The low pressure water system supplies the pump with the following:

- Water of sufficient cleanliness and pressure to the inlets of the two (2) HP cylinders.
- Cooling water of sufficient flow rate and low temperature to the oil-to-water heat exchanger.

6.1 Oil Cooling Water Supply

The oil cooling water supply circuit includes the water modulating valve. Refer to Figure 6.1 for a schematic diagram of the oil cooling water circuit.

See **“Recirculation System”** Section 10.2 for details on adjustment of water modulating valve (2).

The maximum flow rate of the cooling water is specified in Section 11 **“Specifications”** under “Hydraulic Oil Cooling.” A minimum inlet pressure of 40 psig and 70° Fahrenheit maximum inlet temperature is required to maintain oil temperature under extreme operating conditions.

6.2 Cutting Water Supply

Refer to Figure 6.2 for a schematic diagram of the LP cutting The cutting water supply circuit. Refer to the Parts Lists (Section 12) for detailed component information on the LP cutting water circuit. The LP water supply includes the following:

- Low pressure water filter
- Inlet water shutoff valve (solenoid operated)
- Booster pump driven by main motor
- Several pressure gages and switches, and a temperature switch

Most components in the LP cutting water supply circuit are stainless steel or neoprene or other plastic. A stainless steel inlet solenoid shutoff valve (11) is available on request. Pressure and temperature switches are connected to a PLC located in the electrical enclosure. The PLC which monitors out-of-tolerance conditions, including the following:

- Low water pressure at the booster pump inlet (switch (17), T and Q series).
- Low water pressure at the intensifier inlet (switch (16), T and Q series).

- High temperature at the booster pump outlet (switch (2)).
- If the motor does not run for 2 minutes, the solenoid valve (11) will shut off. To re-open the valve, press F6.

Note that pressure gages for T series KMT Waterjet pumps are installed in a frame leg for easy access. Pressure gages provide a qualitative measure of LP water system performance, while pressure switches on the T&Q series pumps provide automatic shutdown protection against out of tolerance conditions.

6.2.1 Normal Operating Condition

During normal operation, the low pressure water system maintains the following conditions:

- Filter pressure drop (gage reading 4 minus 6) not more than 1 bar (15 psi)
- Booster pump inlet pressure greater than 2 bar (30 psi), (T and Q series).
- Booster pump discharge pressure gage reading 8.0-8.3 bar (115-120 psi)
- Intensifier LP cutting water supply pressure greater than 4 bar (60 psi), (T and Q series).
- Water at booster pump outlet maintained at less than 128 deg-F.

NOTE

While the intensifier assembly reverses direction, the booster pressure will fluctuate slightly above and below the normal setting. Pressure fluctuation greater than 2 bar (30 psi) may indicate inadequate water supply to unit, or poor booster pump performance.

6.2.2 Operation

The cutting water enters the pump through port "B". When the CONTROL POWER-- ON button on the operator control panel is activated, solenoid valve (11) opens allowing water to flow through filter assembly (5), then to the inlet of the booster pump (1). The booster pump increases cutting water supply pressure to 8 bar (120 psi) to assure proper supply to both intensifier inlet check valves (13). Pressurized water from the booster pump is supplied to manifold (18). From this manifold, cutting water is routed to the inlet check valves (13) of the intensifier. Note that if a redundant intensifier is installed, the inlet cutting water must be manually disconnected from the inactive intensifier, then connected to the inlet check valves of the inactive intensifier.

NOTE

The booster pump (1) is factory set to deliver 8 bar (120 psi) with an inlet pressure at port “B” of 4 bar (58 psi). The pump may require adjustment if local inlet pressure is different, because discharge pressure depends on inlet pressure. Inlet pressure is affected by filter condition, as well as local water supply conditions.

The LP water filter (5) is located ahead of the booster pump to protect the pump as well as the intensifier and other HP components. The filter gages (4 and 6) indicate the condition of the filter. A difference of 1 bar (15 psi) indicates a dirty filter element that should be replaced.

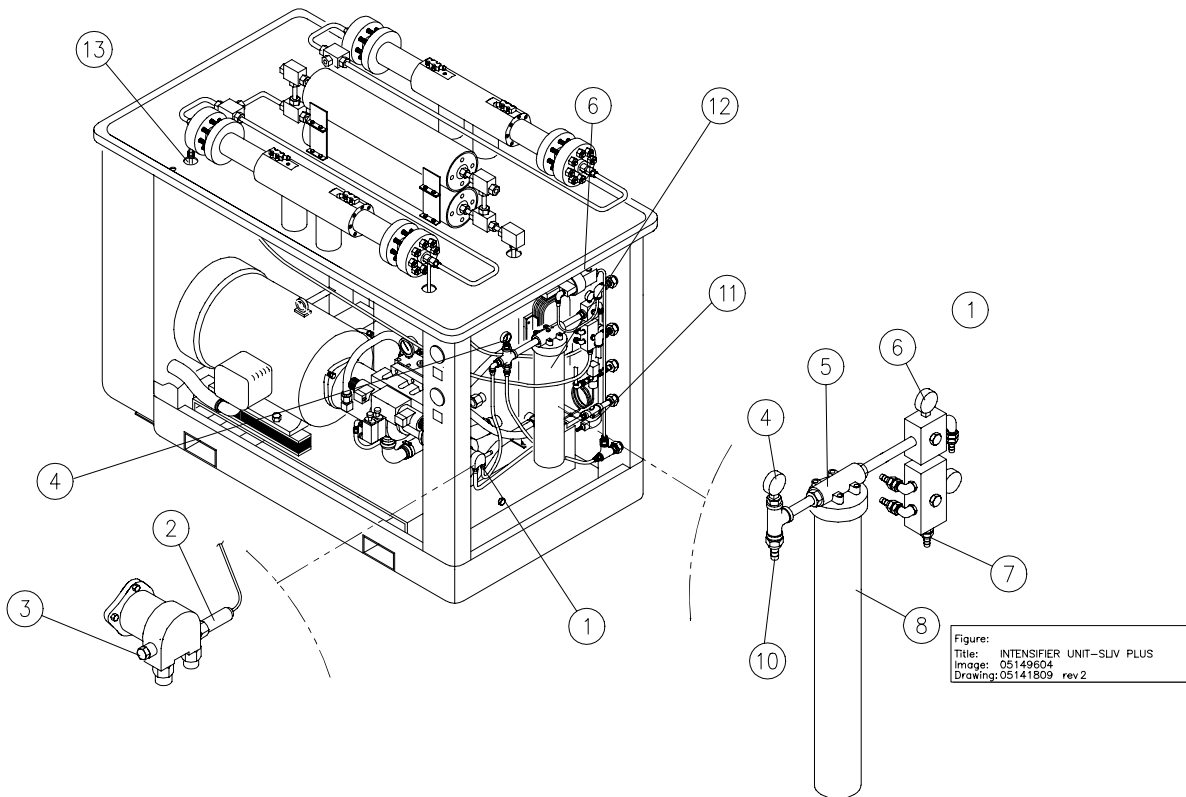

Figure:
Title: INTENSIFIER UNIT-SLIV PLUS
Image: 05149604
Drawing: 05141809_rev2

Item Description

1	Booster Pump	8	Filter Element	15	Intensifier
2	Temperature Sensor	9	Check Valve	19	Manifold
3	Pressure Control Valve	10	Relief Valve	20	Air Bleed Valve
4	Pressure Gage	11	Inlet Solenoid Valve	21	Electric Motor
5	Filter Head	12	Filter Housing		
6	Pressure Gage	13	Intens. Inlet check Valve (2 ea)		
7	Orifice	14	Pressure Gage		

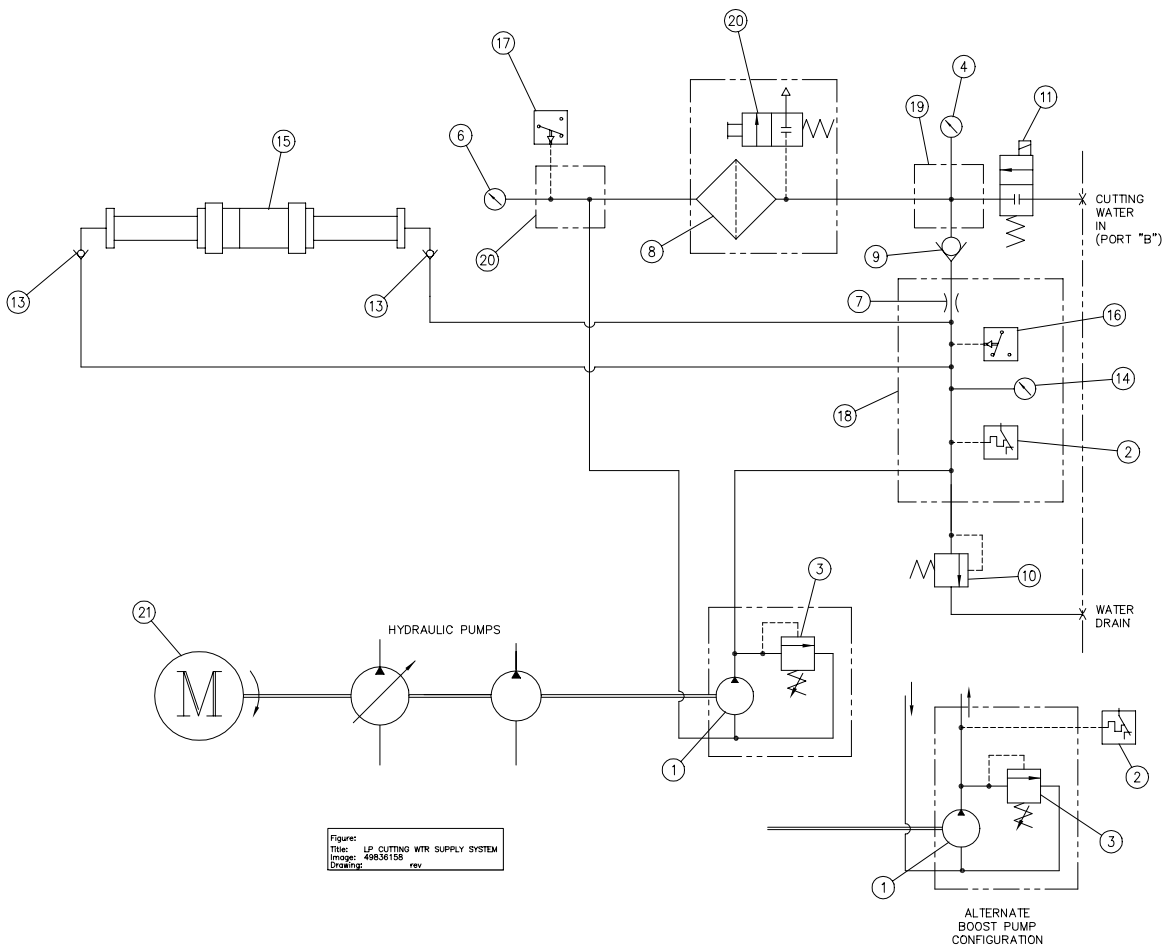

Figure 6.2 LP Cutting Water Supply Circuit

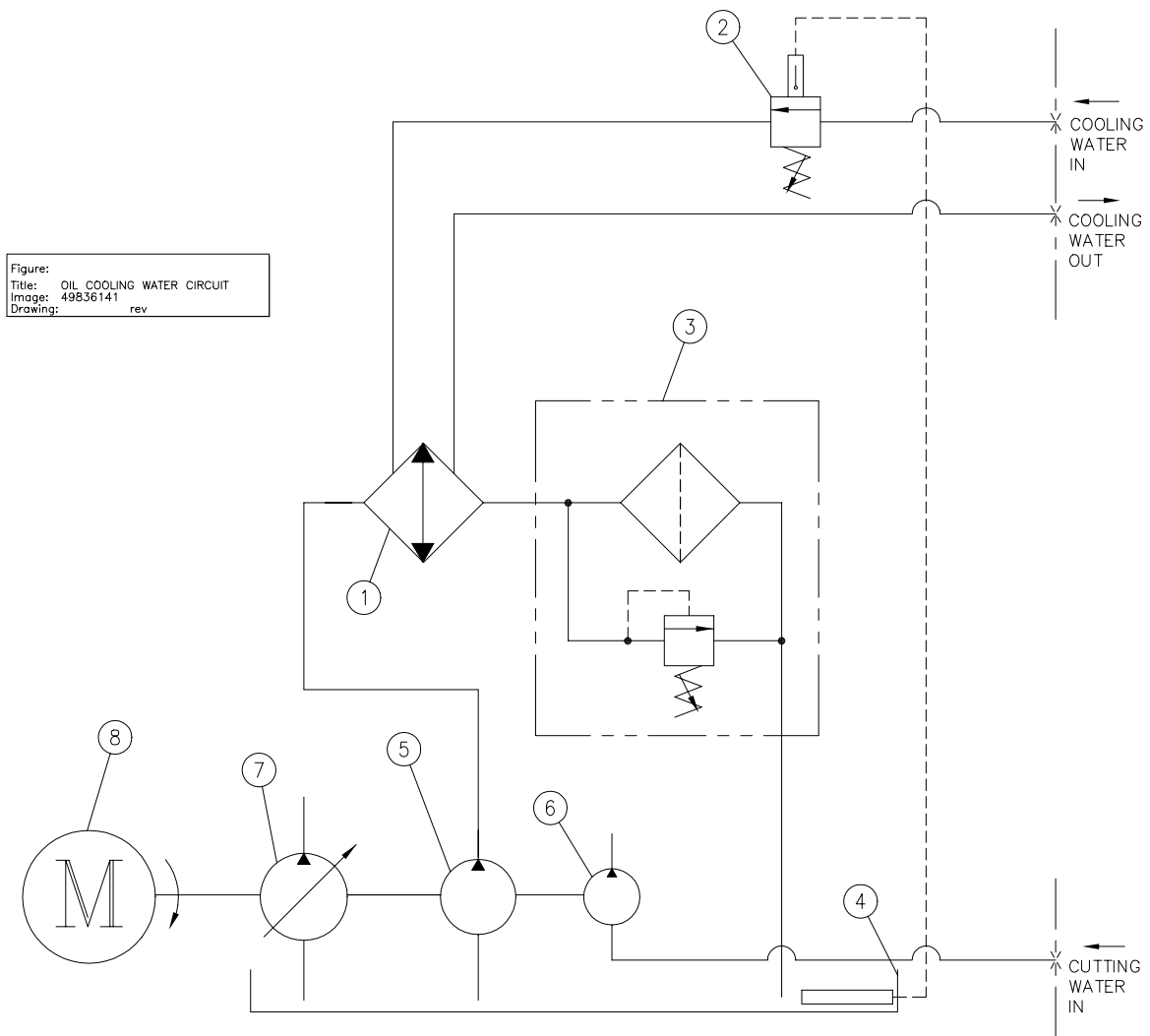

Figure 6.3 LP Water Cooling Circuit

Item Description

- 1 Water/Oil Heat Exchanger
- 2 Water Modulating Valve
- 3 Hydraulic Filter
- 4 Hydraulic Reservoir
- 5 Recirculating Hydraulic Pump
- 6 Water Booster Pump
- 7 Main Hydraulic Pump
- 8 Electric Motor

6.2.3 Booster Pump

The LP cutting water circuit (refer to Figure 6.2) incorporates several features relating to the booster pump:

- a) Booster pump overpressure protection—relief valve (3) is built into the booster pump body and is intended to prevent excessive pump outlet pressure. This relief valve typically operates when the intensifier is dead-headed.
- b) If either check valve (13) leaks, the circuit and booster pump could be subjected to HP water from the intensifier. Inline relief valve (10)—provides circuit and booster pump protection in the event of a leaking check valve (13) at the intensifier.
- c) High cutting water supply pressure could result if circulation were blocked as with dead headed HP water flow. Orifice (7) and check valve (9) allow a minimal amount of LP water to circulate through the filter back to the pump inlet, thereby reducing the likelihood of overheating the cutting water.
- d) If temperature of cutting water at the booster pump outlet is too high, then temperature switch (2) activates an automatic shutdown circuit in the PLC that stops the main electric motor (pumps stop rotating). Note that temperature switch (2) is located on manifold (18) for Q and later T series KMT Waterjet pumps, but is located on the booster pump for earlier series pumps (see Detail A, Figure 6.2)
- e) If water pressure to the booster pump inlet is too low, then the pump might be starved, resulting in pump damage. Pressure switch (17) activates an automatic shutdown circuit in the PLC when pressure drops below the switch setting. Logic in the PLC ignores momentary low pressure signals that might result in erroneous shutdown commands. Typical conditions likely to cause low booster pump inlet pressure are clogged LP filter or problems with the customer-supplied cutting water pressure.

6.2.4 Low Pressure System Protection

The booster pump pressure relief valve (3) is adjusted by turning with a flat blade screwdriver. Turn clockwise to increase pressure or counterclockwise to decrease pressure. Some booster pumps have an exposed adjustment screw, while on others the adjustment screw is accessed by removing an acorn nut.

Control #	Pressure Adjustment		Pressure Settings Bar (psi)	
	Increase	Decrease	Maximum	Minimum
Booster Relief Valve (3)	Clockwise	Counter-clockwise	8.3 (120)	8.0 (115)
LP Manif. Relief Valve (10)	Fixed	Fixed	9.0 (130)	8.6 (125)

The cutting water supply circuit is automatically shut off after the motor has been off for 2 minutes. To reset the water supply valve, press F6. Automatic shutoff of the cutting water supply prevents unnecessary water spillage in the event of an external leak that triggers an automatic shutdown on an unattended KMT Waterjet pump.

6.3 Maintenance Overview

In order to maintain necessary fluid pressure for the pump and to keep the water clean for proper operation it is necessary to replace the water filter and/or adjust the booster pump. The guidelines for servicing these parts are described below.

6.3.1 Water Filter Service

Replace filter elements when there is a 1 bar (15 psi) pressure differential between gages (4) and (6):

Components: Bleed Valve
Element
Head
Housing

Recommended Tools: Supplied filter thread/unthread tool
(to turn housing)
Container (to capture some water spill)
Rags

Parts: Elements for water: 10 micron (quantity 2)
Polymer mixture: 40 micron (quantity 2)

Water Filter Element Replacement Procedure

1. Turn off cutting water supply
2. Press bleed valve to relieve trapped pressure
3. Unscrew housing from head. Remove element.
4. Install new elements in housing. Screw housing into head.
5. Open cutting water supply.
6. Press bleed valve to remove trapped air.
7. Start waterjet pump. Verify satisfactory pressure readings.

6.3.2 Booster Pump

If booster pressure, as read on the booster pump discharge pressure gage (14) is less than 8.0-8.3 bar (115-120 psi), the booster pump needs to be adjusted.

Components: (1) Booster pump
(3) Pressure control knob

Recommended Tools: Flat screwdriver (To turn pressure control knob)
Container (To capture some water spill)
Rags

Parts: None required

Booster Pump Adjustment Procedure

1. Turn on cutting water supply
2. Start waterjet pump and observe booster discharge pressure
3. Stop waterjet pump and press E-Stop button.
4. Remove acorn nut from the side of the booster pump and turn screw clockwise to increase pressure or counter-clockwise to decrease pressure.
5. Replace acorn nut, restart waterjet pump and observe booster discharge pressure.
6. Repeat steps 4 and 5 if necessary.

Section 7 HIGH PRESSURE WATER

7 High Pressure Water

The high pressure (HP) water system takes the relatively low pressure water inlet to up to maximum pressure in excess of 3,400 bar (50,000 psi) supplying orifice diameters appropriate to the waterjet pump's operating power (See Specifications, Section 11).

7.1 Components

The HP water components include the hydraulic intensifier, HP attenuator(s), HP dump valve, HP pressure indicator (optional), and HP piping. Maintenance on the intensifier is discussed in detail in this section. In addition to HP components and assemblies, the hydraulic cylinder features of the intensifier are discussed in this section.

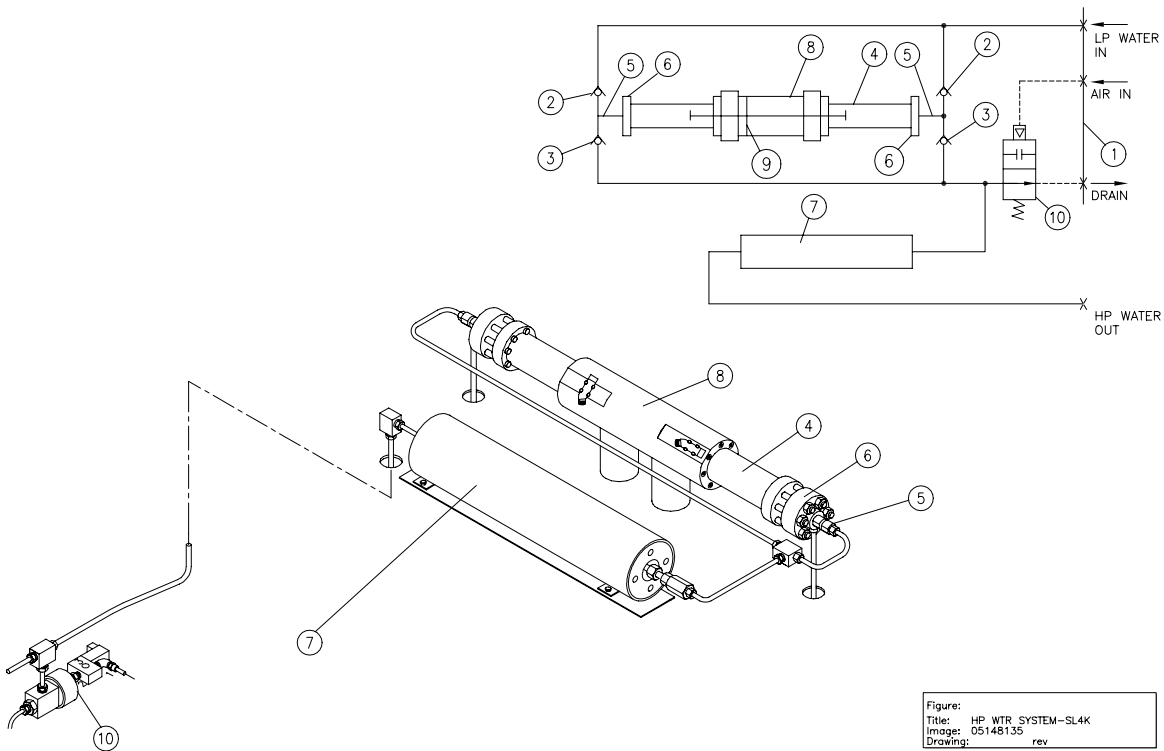

Figure: HP_WTR_SYSTEM-SL4K
Title: 05148135
Drawing: rev

Item Description

- | | | |
|--------------------------|---------------------|-----------------------|
| 1. Bulkhead Fittings | 4. HP Cylinder | 8. Hydraulic Cylinder |
| 2. Inlet Check Valve | 5. Sealing Head | 9. Hydraulic Piston |
| 3. Discharge Check Valve | 6. Sealing Head Nut | 10. HP Dump Valve |
| | 7. HP Attenuator | |

7.2 Intensifier Disassembly and Reassembly

Detailed instructions are provided on disassembly and reassembly of the hydraulic intensifier, including HP seal maintenance. A discussion of detailed inspection and repair for individual HP components and subassemblies is also provided. The HP attenuator is discussed but no disassembly procedures are included. Note that HP attenuators are not considered to be serviceable by the customer.

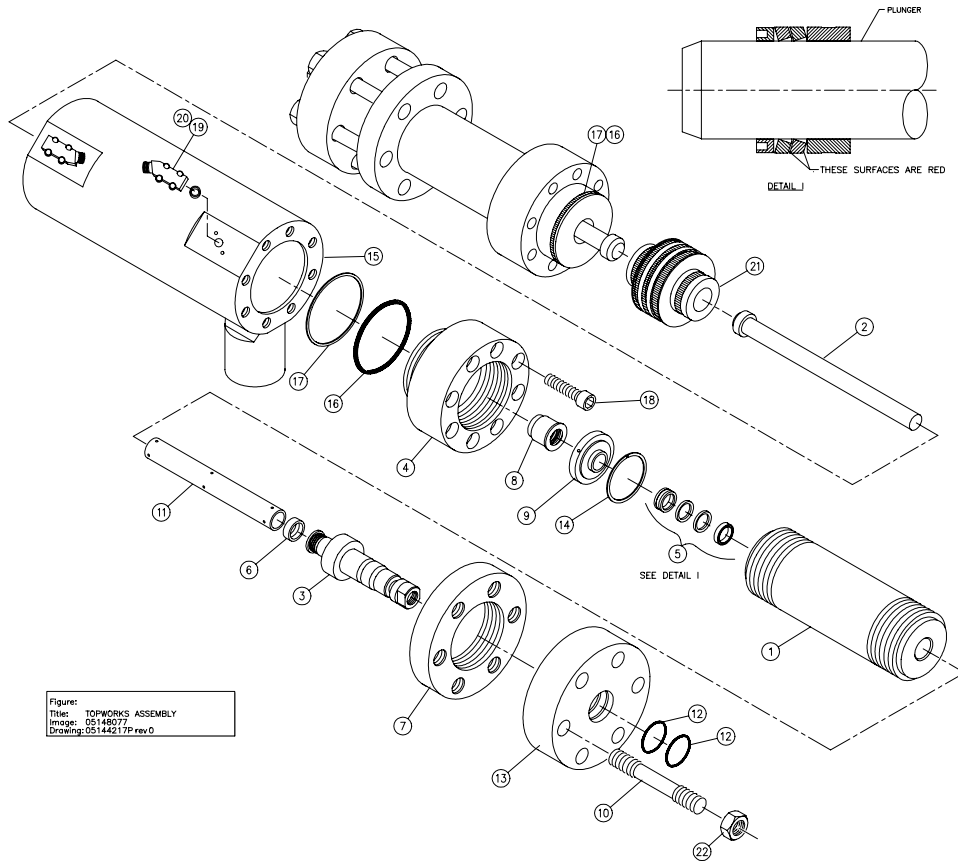

Item Description

(1) HP Cylinder	(2) Plunger	(3) Sealing Head
(4) Hydraulic Cylinder Head	(5) HP Seal	(6) Ring
(7) Ring Flange	(8) Hydr Seal Cartridge	(9) Retaining Flange
(10) Stud Bolt	(11) Cylinder Liner	(12) O-ring
(13) End Flange	(14) Retainer Ring	(15) Hydraulic Cylinder
(16) Back-up Ring	(17) O-ring	(18) Cap Screw
(19) Proximity Switch	(20) Cap Screw	(21) Piston Assembly
(22) Hex Nut		

Standard HP gland nut hex sizes for HP piping is as follows:

- 3/8" HP fittings: 13/16" (open end) wrench.
- 9/16" HP fittings: 30mm (1-3/13") wrench.
- Tie bolts nuts: 1-7/16" socket (7/8" and 1-1/8" plunger models)

**7.2.1 HP & LP Water Piping
Disconnect from/Reconnect to Waterjet Pump****WARNING**

Before performing maintenance on the waterjet pump observe electrical LOCK OUT/TAG OUT procedures.

1. Loosen and remove HP Piping attached to the discharge HP check valve. Move tubing to clear work area.
2. For servicing the discharge HP check valve on the intensifier assembly, refer to section 7.3.1. "Discharge HP Check Valve". Note that the sealing head can be removed with the discharge HP check valve attached.
3. Disconnect LP water at end flange. Note that to service the sealing head, including the inlet HP check valve, the tie bolts must be loosened allowing removal of the end flange.
4. With the HP piping and the LP cutting water plumbing disconnected, the following operations can be performed:
 - HP cylinder can be removed from hydraulic cylinder head
 - HP plunger seal can be serviced

After the pump has been reassembled, then the HP water piping and LP water disconnect are reinstalled as follows:

5. Slide inlet water collar over sealing head until it rests against the head nut. Connect LP inlet water quick disconnect to collar.
6. Install the HP water piping to the intensifier. Check HP fittings for proper collar position (1 to 1-1/2 threads exposed) and for adequate thread lubricant (High Purity Goop). Turn on cutting water supply and check for low-pressure leaks.

**CAUTION**

Check that all proximity switches are properly installed and secured prior to starting the motor. Failure to tighten proximity switch hold down screws (2 each per proximity switch) will result in hydraulic oil spraying in general directions.

7. Start the waterjet pump. Operate at low pressure (without a cutting orifice) to flush the HP passages, then operate at high pressure with orifice installed to check for leaks.

**7.2.2 HP Cylinder “Jug” (HP Cyl., Sealing Head, Flanges, & Studs)—
Disassembly / Re-assembly**

NOTE—KMT Waterjet recommends removing the HP cylinder/ sealing head/ flanges AS AN ASSEMBLY for servicing the plunger HP seals, plunger, hydraulic seals, etc. KMT Waterjet DOES NOT recommend loosening stud nuts except to service the sealing head inlet HP check valve, cone seat, etc. Refer to Table 7.1 for recommended disassembly / re-assembly practices.

Due to the weight (approx. 70 lbs) of the HP cylinder jug, adequate support should be provided to prevent damage to the plunger or seals during disassembly/ re-assembly. See Figure 7.2 for suggested special tools to support the HP cylinder jug for this procedure.

**HP Cylinder Jug Removal**

1. Prior to removing electrical power from the pump, extend plunger on end to be serviced. Remove connector from proximity switch on end of hydraulic cylinder closest to HP cylinder jug to be removed. Start the pump in LOW pressure mode, allow approximately 20 seconds for appropriate startup and cycling of intensifier to extend and stop toward the disconnected proximity switch. Shut off the pump, shut off LP water supply, observe LOCK-OUT/ TAG-OUT safety rules.



Before performing maintenance on the waterjet pump observe electrical LOCK OUT/TAG OUT procedures.

2. Disconnect HP and LP piping / hoses per paragraph 7.2.1 above.
3. With support cradle tool located under HP cylinder jug, unthread and remove jug from plunger and hydraulic cylinder head.

NOTE: several methods for rotating the HP cylinder jug are available. The cylinder wrench is available, or the jug can be rotated by hand with the help of the studs and stud nuts. A slight lift force applied to the HP gland nut of the outlet HP check valve can help ease the effort of rotating the HP cylinder jug.

HP Cylinder Jug Re-Installation

1. Verify that HP cylinder threads are adequately lubed with High Purity Goop and that the threads have been sanded/ dressed if galling was encountered during HP cylinder jug removal.
2. Verify that the HP plunger seals, packing follower, and plastic cylinder liner tube are correctly installed. Align HP cylinder jug with plunger using cradle tool to support weight and provide approximate alignment. Carefully push/ lift jug into place until threads are ready to engage.

3. While lifting upward on the outlet HP check valve gland nut, push upward on a stud nut, rotating the jug CW, while pushing inboard and upward until thread engagement is accomplished. Continue to thread HP cylinder into hydraulic cylinder head until hand tight.
4. Re-connect HP and LP piping / hoses per paragraph 7.2.1 above.

**CAUTION**

Check that all proximity switches are properly installed and secured prior to starting the motor. Failure to tighten proximity switch hold down screws (2 each per proximity switch) will result in hydraulic oil spraying in general directions.

5. Restart the pump, first operating in LOW pressure mode to flush out air in HP components and also to check for obvious leaks. Switch to HIGH pressure after 5-10 minutes of LOW pressure operation, watching for obvious leaks. Be ready to shut off the pump if leaks appear. Remedy leaks then repeat start procedure, moving from LOW pressure to HIGH pressure soon after intensifier starts pumping water (no further need to flush air from lines).

7.2.3 Stud Nuts and End Flange, Sealing Head—Disassembly / Re-assembly

NOTE—KMT Waterjet recommends removing the HP cylinder/ sealing head/ flanges AS AN ASSEMBLY for servicing the plunger HP seals, plunger, hydraulic seals, etc. KMT Waterjet DOES NOT recommend loosening stud nuts except to service the sealing head inlet HP check valve, cone seat, etc. Refer to Table 7.1 for recommended disassembly / re-assembly practices.

End Flange and Sealing Head Removal

1. Prior to removing electrical power from the pump, extend plunger at intensifier end to be serviced. Remove connector from proximity switch on end of hydraulic cylinder closest to HP cylinder jug to be removed. Start the pump in LOW pressure mode, allow approximately 20 seconds for appropriate startup and cycling of intensifier to extend and stop toward the disconnected proximity switch. Shut off the pump, shut off LP water supply, observe LOCK-OUT/ TAG-OUT safety rules.

**CAUTION**

Before performing maintenance on the waterjet pump observe electrical LOCK OUT/TAG OUT procedures.

2. Disconnect HP and LP piping / hoses per paragraph 7.2.1 above.
3. Loosen stud nuts, then remove nuts.
4. Remove end flange. Note that sealing head may be removed with end flange.

5. Remove sealing head. Note that a white plastic ring used to position the sealing head relative to the HP cylinder bore may not have been removed with the sealing head. This ring should be removed prior to re-installing a sealing head to avoid pushing the ring further into the HP cylinder bore. Note that a fully- assembled spare sealing head greatly reduces pump downtime.

Re-Assemble Sealing Head and End Flange to HP Cylinder

1. Verify that sealing head cone surface is smooth. Perform any necessary maintenance on inlet check valve. (Refer to paragraph 7.3.2) Verify that a white plastic alignment ring is installed on the 'nose' of the sealing head. Verify O-rings (2 ea) properly installed in ID grooves of end flange. Check HP cylinder bore to verify presence of plastic tubular cylinder liner and to verify that no white plastic alignment ring remains in end of HP cylinder bore. Feel sealing edge of HP cylinder bore to verify that no unusual blemishes are present that might hinder proper cone ring seal.
2. Install sealing head into end flange. Install sealing head and end flange over stud bolts and into cylinder bore. Note that end flange should be oriented with the LP water fitting oriented near the 9 o'clock or 3 o'clock positions for ease of making the LP water connection.
3. Thread nuts onto studs to hand-tightness. Apply molygrease to stud threads (Table 7-2 item 3). Verify end flange and ring flange are parallel to within 0.070-inch.
4. Tighten stud nuts (using a torque wrench) in a crossing pattern in several stages to reach maximum torque. See Table 7.1 for suggested nut tightening sequence. Verify flange parallelism at completion of tightening sequence.
5. Re-connect HP and LP piping / hoses per paragraph 7.2.1 above.

**CAUTION**

Verify that proximity switches (2 ea) are properly installed. Failure to tighten proximity switch hold down screws will result in hydraulic oil spraying in general directions.

6. Restart the pump, first operating in LOW pressure mode to flush out air in HP components and also to check for obvious leaks. Switch to HIGH pressure after 5-10 minutes of LOW pressure operation, watching for obvious leaks. Be ready to shut off the pump if leaks appear. Remedy leaks then repeat start procedure, moving from LOW pressure to HIGH pressure soon after intensifier starts pumping water (no further need to flush air from lines).

7.2.4 HP Plunger Seal Service-- Disassembly / Re-assembly

1. Remove HP and LP piping/ hose, then remove HP cylinder jug following procedure 7.2.2, above.
2. Thread HP plug and gland fitting (items C1 & C2, Special Tools, Table 7.3) into HP check valve gland nut. Hand tight is sufficient.
3. Stand HP cylinder jug upright with stud nuts resting on platform of wood blocks or stand tool item (B), Table 7.3.

DANGER: HP cylinder jug is heavy and if it is stood on top pan of the pump, will present a falling object hazard. Take care to properly support jug so that it will not fall.

4. Fill HP cylinder bore with water, then fit a used plunger or seal removal tool (item (E), Table 7.3) into bronze packing follower. Note that wrapping a shop rag around the plunger at the packing follower avoids splash-back. Use a dead blow hammer to strike the button end of the plunger as though attempting to drive the plunger into the HP cylinder. This technique should 'hydraulic' the HP seal components upward onto the plunger/ tool shaft and out of the HP cylinder.
5. Slip plastic liner tube from bore of HP cylinder, inspect for possible heat or wear damage or for possible debris. Feel ID of HP cylinder for approximately 1-inch into bore. Sand any obvious ridges or grooves with 600-grit wet/dry sandpaper. Note that grooves or ridges are typically caused by seal debris buildup rather than by marks in ID wall of HP cylinder.
6. Inspect plunger surface for flaws. Rotate plunger 360- degrees by hand while viewing light reflection on plunger surface to note any dullness, streaks, pits or other defects. Run fingernail perpendicular to direction of suspected surface flaws to gage severity of defects. Depending on seal life achieved with removed HP plunger seal, make judgment regarding whether to replace plunger. Refer to Paragraph 7.2.6 for procedure regarding plunger removal/ installation.
7. Lightly coat seal components with FML grease refer to Table 7-2 item 1 prior to installing seal parts on plunger. Install new HP plunger seal assembly onto plunger, refer to Figure, Detail I, (paragraph 7.2) for proper seal component orientation. Note that steel spring inside U-cup (if so equipped) can be easily distorted. Verify that U-cup spring, lips and cavity appear uniform prior to installation.

NOTE: Bronze packing follower intended to fit tightly on plunger. If follower is too tight to slip onto plunger, try heating follower in hot water. Then attempt to slip follower over plunger.

8. Slip plastic cylinder liner tube over plunger.
9. Install HP cylinder jug to hydraulic cylinder head per paragraph 7.2.2.

TABLE 7.1 FLANGE NUT TORQUE SPECIFICATIONS

Plunger Diameter	7/8" Diameter Plunger (SL-IV Plus)		1-1/8" Diameter Plunger (SL-IV 100S)	
No. of Studs, Tightening Sequence	6 each (Fig A)		8 each (Fig B)	
Units	N-m	Ft-Lb.	N-m	Ft-Lb.
1 st Stage	Hand Tight	Hand Tight	Hand Tight	Hand Tight
2 nd Stage	135	100	135	100
3 rd Stage	200	150	200	150
4 th Stage	257-285	190-210	257-285	190-210
Max Out-of Parallel	1.8mm	0.070"	1.8mm	0.070"
Socket Wrench Size	1-7/16"		1-7/16"	

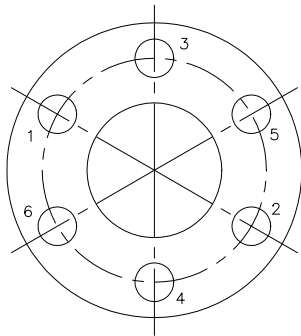

6-BOLT CROSSING PATTERN
FIG. A

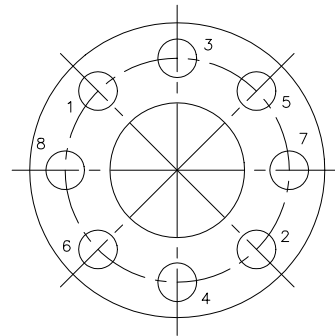

8-BOLT CROSSING PATTERN
FIG. B

Table 7-2. Lube Specs KMT Intensifier Pumps

Item No.	IR P/N	Description	Applications
1	10087385	FML Grease, White	Lube Parts, HP Cylinder
2	10084440	High Purity Goop-SS Thds	SS Threads
3	49832199	Moly Disulfide Grease	Non-SS Thds

Table 7.2 HP INTENSIFIER SERVICE TEARDOWN SEQUENCE

		Disassemble/Re-assemble						
Intensifier Component Maintenance	Related Component Assembly	HP Piping	LP Water Plumbing	HP Cylinder Sealing Head, Flanges & Studs [1]	Stud Nuts & End Flange	Retainer Flanges & Hydraulic Cartridge	Hydraulic Cylinder Head	
Ref Part No.→	--	7.2.1	7.2.1	7.2.2	7.2.3	7.2.5	7.2.6	
1	Outlet HP Check Valve	Sealing Head	Yes	No	No	No	No	No
2	Inlet HP Check Valve	Sealing Head	Yes	Yes	No	Yes	No	No
3	HP Plunger Seal	HP Cylinder	Yes	Yes	Yes	No	No	No
4	Hydraulic Seal Cartridge-Plunger	Hydraulic Cylinder Head	Yes	Yes	Yes	No	Yes	No
5	Sealing Head Cone Seal	Sealing Head	Yes	Yes	No	Yes	No	No
6	HP Cylinder	--	Yes	Yes	No	Yes	No	No
7	Plunger	--	Yes	Yes	Yes	No	Yes	No
8	Hydraulic Piston	--	Yes	Yes	Yes	No	No	Yes

Note [1]:Remove/installed as a unit (HP Cylinder “Jug”)

7.2.5 Plunger and Hydraulic Cartridge Removal and Installation

1. Remove HP and LP piping/ hose, then remove HP cylinder jug following procedure 7.2.2 above.
2. Remove the proximity switch on the intensifier side nearest HP cylinder to be serviced. This procedure will allow hydraulic oil to drain to tank and will minimize oil spillage. Draining takes about 5 minutes. Remove cartridge retainer flange from hydraulic cylinder head by first removing retaining ring using a flat blade screwdriver. Wipe and clean surfaces, weep holes, and grooves in cartridge retainer flange. Check retainer flange for cracks.
3. Using cartridge/plunger removal tool threaded to the seal cartridge, pull the cartridge outward over the plunger. Seals in the hydraulic cartridge can be removed and replaced, or the entire cartridge can be replaced. It is recommended that at least one spare cartridge be kept on hand, ready to install. See Section 7.3.6 for servicing hydraulic seal cartridge.
4. With the cartridge removed, the plunger can be removed with the cylinder head in place. Slide the cartridge/plunger removal tool over the plunger, with the hex-shaped smaller end toward the plunger button. Note orientation of plunger button retainer pins (6 each), then align hex flats of tool with pins. Force tool by hand under pins, then rotate tool slightly to cause pins to retract enough to release plunger. Plunger can now be extracted from hydraulic piston. See Section 7.3.5 for servicing the plunger.
5. To install new plunger, slip cartridge/plunger removal tool over plunger, hex end toward plunger button, to help center plunger in cylinder head. Position plunger in mating pocket of piston, then force into place by hand. Using a flashlight, verify that all 6 pins are equally extended to grip plunger button.
6. Lubricate exposed surfaces of seals in hydraulic seal cartridge with food grade grease and slide cartridge over plunger into cylinder head cavity.
7. Thoroughly clean cartridge retainer flange, including cross-drilled weep holes. Install flange and internal retaining ring, making sure that the retaining ring seats fully inside its groove. Note that hydraulic cartridge O-rings may take up clearance. To install retaining ring, first tap lightly on retainer flange using plunger removal tool. This will compress cartridge O-rings enough to get retaining ring started in groove. Push on outer edge of retainer flange with a flat bladed screwdriver while working one end of retaining ring into groove. Retainer flange should tilt or tip enough to allow retaining ring to move into its groove. Continue working ring into groove while tilting flange until retaining ring is fully installed.
8. Install HP cylinder jug to hydraulic cylinder head per paragraph 7.2.2.

7.2.6 Hydraulic Cylinder Head and Piston—Removal / Re-Installation

1. Remove HP and LP piping/ hose, then remove HP cylinder jug following procedure 7.2.2 above.
2. Remove proximity switch (19) at cylinder end to be serviced. Loosen the remaining proximity switch to drain hydraulic oil in tank.
3. Remove hydraulic seal cartridge (8). Seal cartridge (8) removal is recommended to avoid sliding cylinder head (4) over plunger (2). The plunger need not be removed at this stage.
4. Loosen and remove 8 each socket head cap screws (18) retaining cylinder head (4) to hydraulic cylinder (15). The cylinder head and its O-ring (16) can be removed. The proximity switch mounting flats provide a small lip for loosening the cylinder head.
5. To remove the hydraulic piston (21) from the hydraulic cylinder (15), remove one cylinder head, remove the proximity switch toward that end. On the opposite end remove the HP cylinder and end cap, then remove the retainer flange and hydraulic cartridge. The piston must be driven from the cylinder bore due to the seal squeeze and friction. Use a plastic head hammer to avoid striking the assembly with a metal object. See Section 7.3.7 for servicing the hydraulic piston.
6. Reassemble the hydraulic cylinder by reversing the above steps.
Tighten 12M socket head capscrews (8 per cylinder head) in a crossing pattern to 190-210 N-m (140- 155 ft-lbs).

CAUTION--Remember to install and tighten proximity switches. Failure to do so will result in considerable spraying of hydraulic oil.

7. Install HP cylinder jug to hydraulic cylinder head per paragraph 7.2.2.

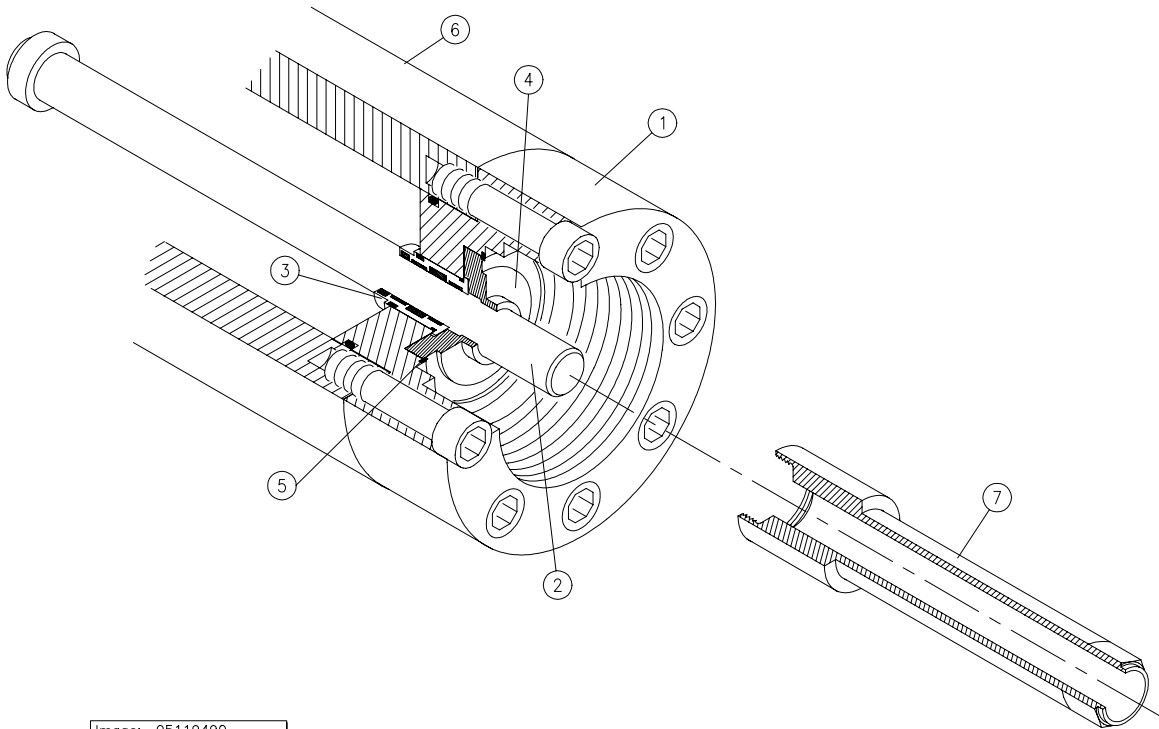

Image: 05119490
Drawing: 05113030 rev

Item Description

- | | |
|--------------------------------------|----------------------------|
| 1. Cylinder Head | 4. Bushing Retainer Flange |
| 2. Plunger | 5. Retaining Ring |
| 3. Hydraulic Cartridge, Plunger Seal | 6. Hydraulic Cylinder |
| | 7. Plunger Removal Tool |

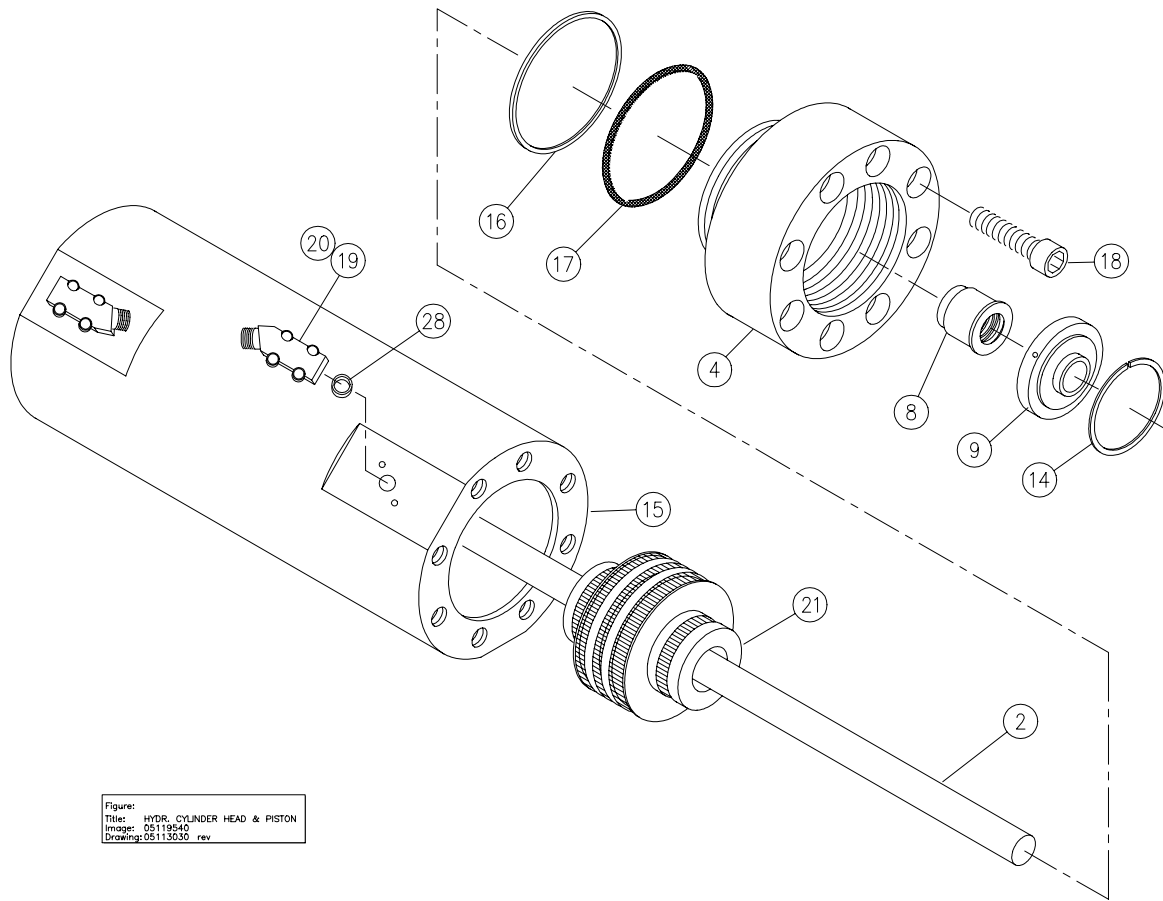

Figure:
Title: HYDR. CYLINDER HEAD & PISTON
Image: 05119540
Drawing: 05113030_rev

Item Description

2.	Plunger	9.	Bushing Retainer Flange	18.	Cap Screw
4.	Cylinder Head	15.	Hydraulic Cylinder	19.	Proximity Switch
8.	Hyd Cartridge, Plunger Seal Assy	16.	O-ring	20.	Cap Screw
		17.	Backup Ring	21.	Hyd Piston Assy
				28.	Spacer

7.3 Intensifier Subassemblies Inspection and Repair

The inspection and repair of the following subassemblies will be discussed:

- Discharge HP Check Valve, Section 7.3.1
- Inlet Check Valve, Section 7.3.2
- Sealing Head, Section 7.3.3
- HP Cylinder, Section 7.3.4
- Plunger, Section 7.3.5
- Hydraulic Seal Cartridge, Section 7.3.6
- Hydraulic Piston, Section 7.3.7
- Hydraulic Cylinder, Section 7.3.8

7.3.1 Discharge HP Check Valve

The HP discharge check valve can be serviced with the sealing head either installed in or removed from its intensifier HP cylinder.

1. Remove the gland nut from the sealing head using a pair of wrenches.
2. When the gland nut is removed, the spring guide and spring will normally stay in the gland nut. The seat is removed with a magnet. Inspect the seat for damage or cracking. A cracked seat should be replaced. The seat is symmetrical, and can be installed with either face toward the poppet. Note that a slight burr at the hole edge identifies the used side of the poppet seat. When reinstalling the seat, apply a thin film of High Purity Goop to both faces. Install the seat into the sealing head with the best surface facing the check poppet.

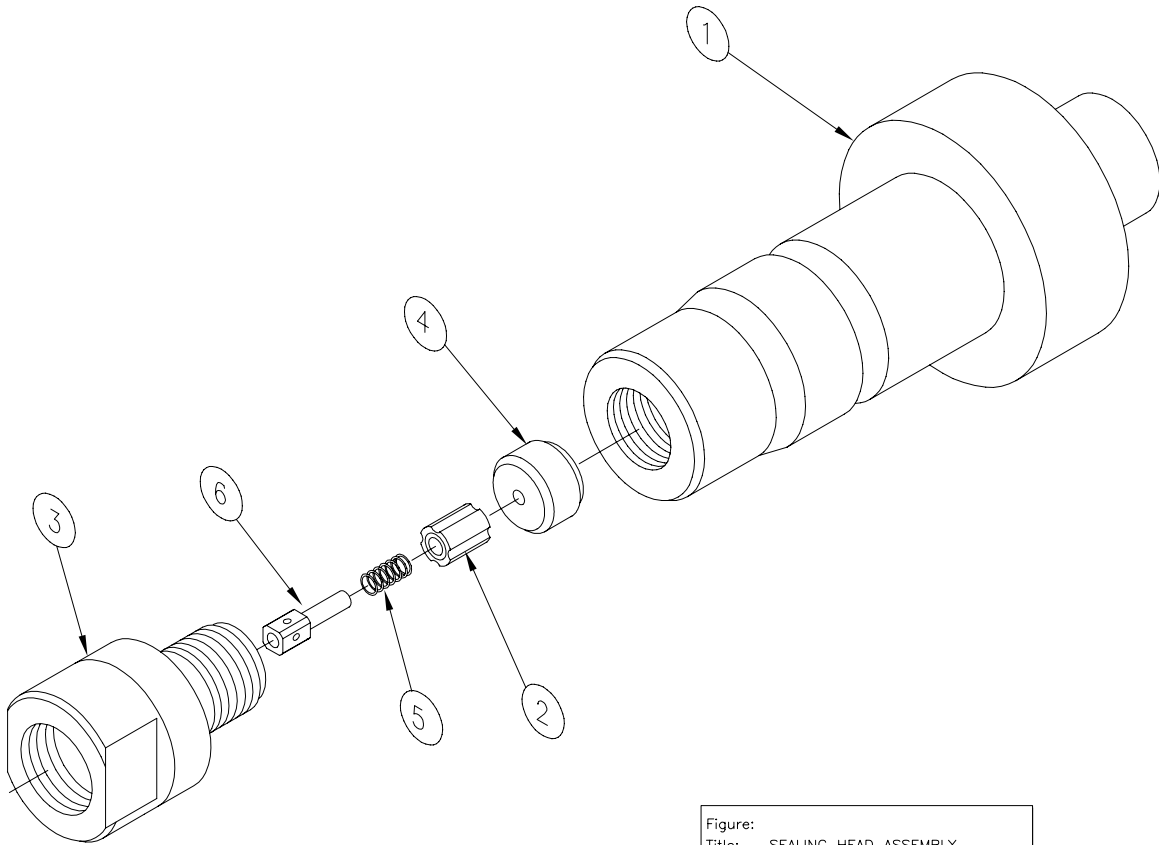

Figure:
Title: SEALING HEAD ASSEMBLY
Image: 05114798
Drawing: 05116769P rev 4

Item Description

- | | | |
|------------------|------------|---------------|
| (1) Sealing Head | (2) Poppet | (3) Gland Nut |
| (4) Poppet Seat | (5) Spring | (6) Guide Pin |

3. Inspect the poppet, spring, and guide for wear. Replace the spring and guide if worn.
4. Apply a thin film of High Purity Goop to the sealing face of the gland nut. Install the guide, spring, and poppet into the gland nut.
5. Apply High Purity Goop to the gland nut threads. Install the gland nut into the sealing head. The gland nut should be hand tightened until there is a gap of 5mm (0.20") between the gland nut and sealing head. No threads should show. If the gap exceeds 5mm (0.20"), then one of the parts has slipped out of place, and they must be removed, inspected and reassembled.
6. Using a crowfoot/torque wrench combination, torque the gland nut to 176 Nm (130 ft-lbs.).
7. Reconnect high pressure and low pressure piping, per Section 7.2.1. Operate waterjet pump to verify HP fittings do not leak, and that the HP water signal is normal (indicative of normal check valve operation).

7.3.2 Inlet Check Valve

1. Use a ½” flat bladed screwdriver to unscrew the poppet retainer from the sealing head. The inlet check valve is disassembled.
2. Inspect and refinish the sealing head face seal surface per instructions in Section 7.3.3.
3. Inspect both surfaces of the flat washer shaped poppet. If one surface is marred, and the opposite surface is not, the poppet may be reversed with the best surface facing the sealing head. If both sides are worn, replace poppet.
4. Assemble poppet (2) and spring (7) on poppet retainer (11). Apply small amount of Loctite 222 thread locker to thread of poppet retainer, taking care not to get Loctite on poppet or other inlet check valve sealing surfaces.
5. Tighten poppet retainer (11) using 1/2-in. flat blade screwdriver taking care not to twist off poppet retainer. If torque wrench tools are available, tighten to 25-30 in-lbs.
6. Inspect the assembled unit to insure the following:
 - The poppet moves freely.
 - The spring is fully guided on the poppet retainer.
 - The spring end is 90° from the retainer’s screwdriver slot.
 - The poppet retainer is shouldered against the sealing head.

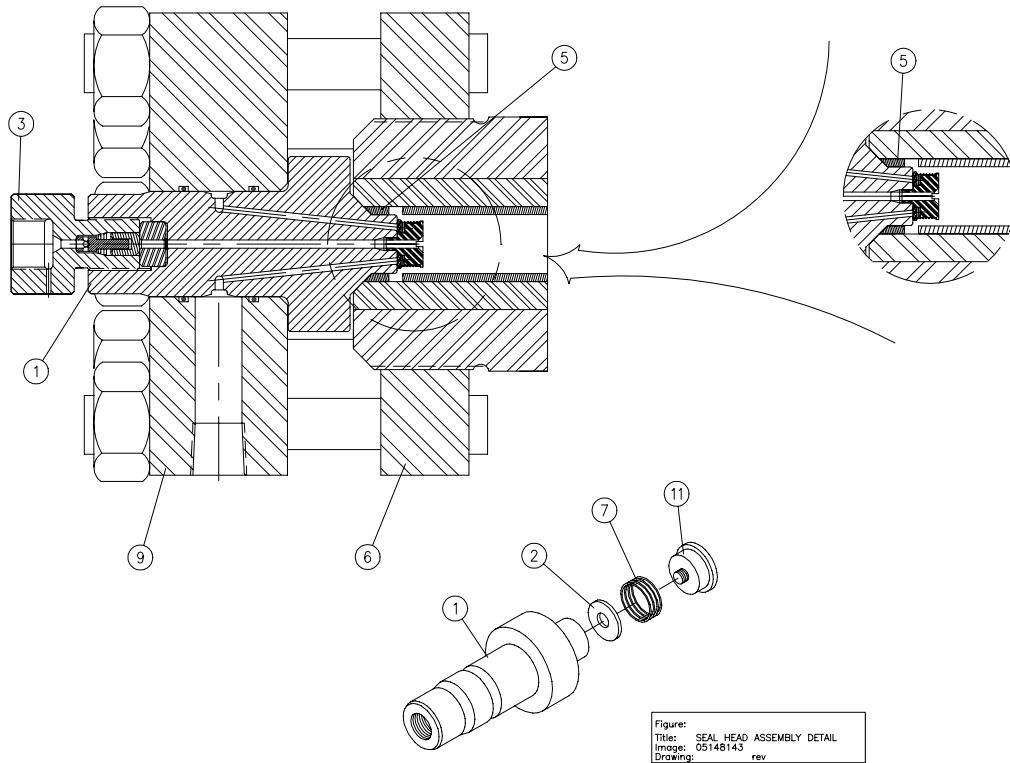

Item Description

- | | | |
|----------------------|-----------------|--------------------|
| (1) Sealing Head | (2) Poppet | (3) Gland Nut |
| (5) Seal Head Spacer | (6) Flange Ring | (7) Suction Spring |
| (9) End Flange | (11) Retainer | |

7.3.3 Sealing Head

The sealing head should be inspected for scratches and wear on two surfaces:

- HP cone ring seal contact surface
 - Inlet HP check valve poppet contact surface
1. Polish the cone ring 45 degree surface to achieve a smooth finish. Grooves or machine tool marks should be barely discernable by fingernail test.
 2. Inspect the inlet poppet sealing surface of the sealing head for pits, scratches, or jetting erosion. Refinishing the seal head inlet poppet face is mandatory when rebuilding the sealing head. Using a piece of plate glass (not window glass) on a sturdy table, place a piece of 400 grit wet/dry sandpaper atop the plate of glass which provides the absolutely flat surface necessary for the polishing process. Using even, deliberate strokes, polish the sealing head until smooth. Rotate the head about 10-15 degrees every stroke. Be careful not to tilt or tip the head while polishing it as to not scrape the part.
 3. When the sealing head is flat and smooth, perform a final polish with 600 grit wet/dry sandpaper. A mirror finish is required. Ingersoll-Rand offers a refinishing service.

7.3.4 HP Cylinder

1. At a workbench, use the seal removal tool to prevent scratching the cylinder bore sealing surface. Use a pulling action to remove the sealing head HP seal.
2. Remove the bore liner. Use a plastic-faced hammer and the seal removal tool to drive out the plunger HP seal and follower. Be careful not to scratch the bore of the cylinder or damage the cylinder threads.
3. Clean sealing areas of HP cylinder inside diameter and inspect cylinder for rings, scratches, pits, residue build-up and other potential leak paths. Seal material or residue can build up forming a ring, and running a fingernail across it, will cause it to appear as a surface flaw. It is usually necessary to clean the area before performing an inspection.
4. Use 600 grit wet/dry sandpaper to polish HP cylinder inside diameter where the seal will locate. Polish only in a circumferential motion. Do not polish or drag the sandpaper along the length of the cylinder. Hold the sandpaper on the end of your finger, and move in a cylindrical wiping motion in the bore of the HP cylinder. Wipe residue from cylinder inside diameter and re-inspect for surface defects.

NOTE

The HP cylinder ends often show a “step” between inner and outer sleeves where the inner sleeve extends beyond the outer by a small amount. This is normal and does not indicate a flaw in the cylinder.

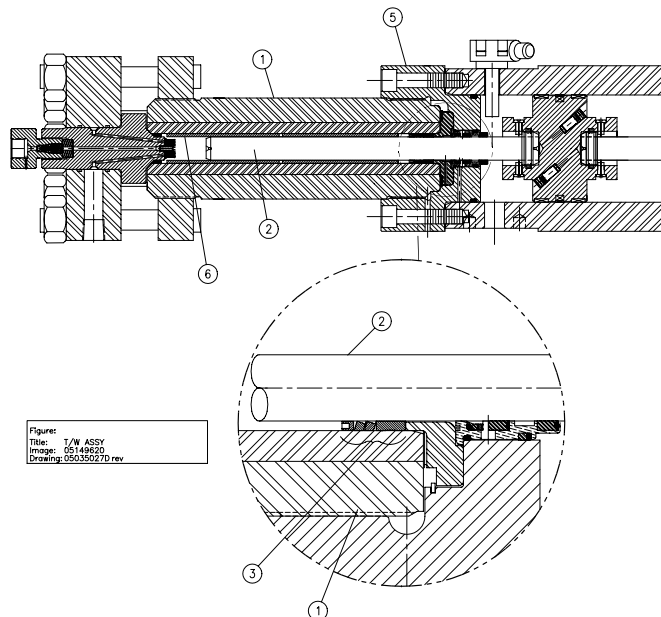

Item Description

- | | |
|---------------------------|-------------------|
| (1) Cylinder Body | (5) Cylinder Head |
| (2) Plunger | (6) Liner |
| (3) Plunger Seal Follower | |

7.3.5 Plunger

Plunger surfaces can become streaked with longitudinal scratches or flaws, the surface can become discolored or dull in appearance, or the outboard end can become smeared with stainless steel due to contact with the bore liner. If any of these conditions become severe, the plunger HP seal and possibly the hydraulic seals will leak excessively. Repair of plunger surface flaws usually cannot be accomplished on site. KMT Waterjet offers a plunger reconditioning service.

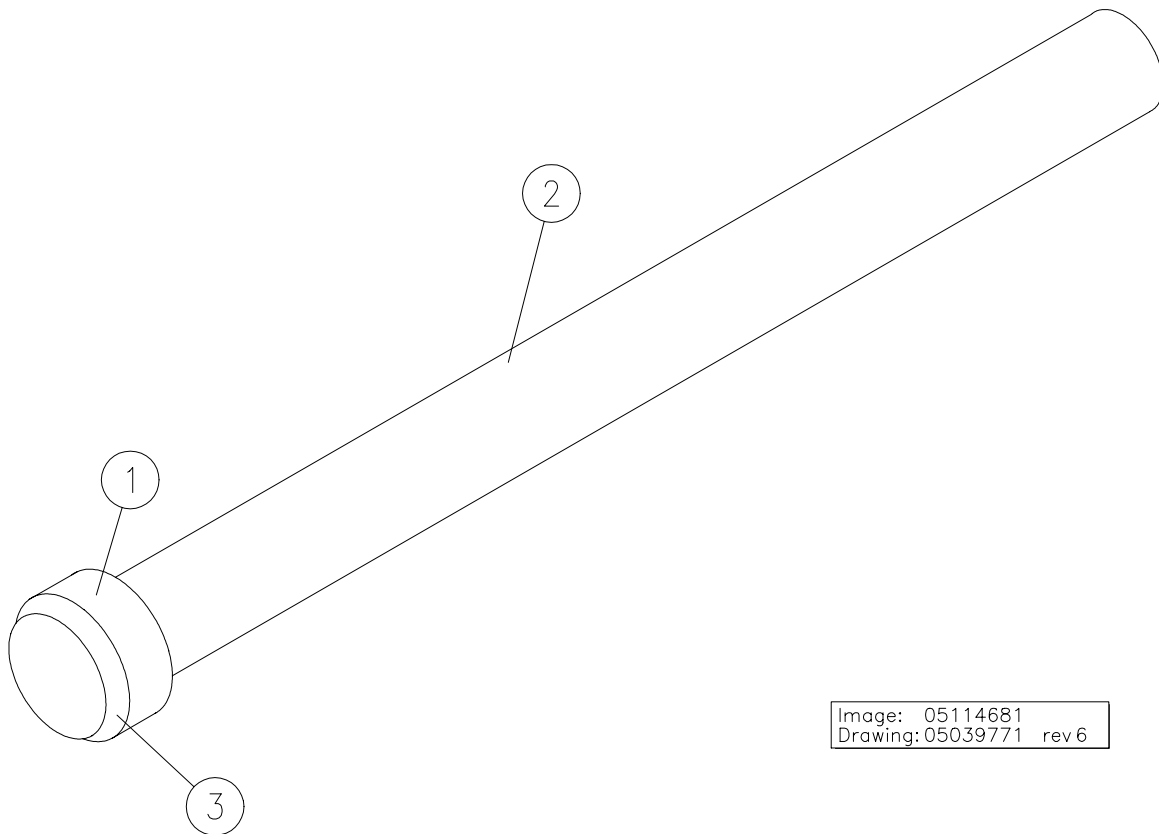
**Item Description**

(1) Plunger Button

(2) Plunger

(3) Button Chamfer

7.3.6 Hydraulic Seal Cartridge

Carefully remove worn seals and O-rings from cartridge by pushing them with a dowel or similar object. Remove seals positioned close to the open ends first, working toward the interior. Examine seals for unusual wear, deformation or cuts. Note any unusual buildups of solid material or debris causing possible leak paths.

Examine the cartridge body (1) surfaces for scratches, signs of metal-to-metal contact, deformation or other unusual wear.

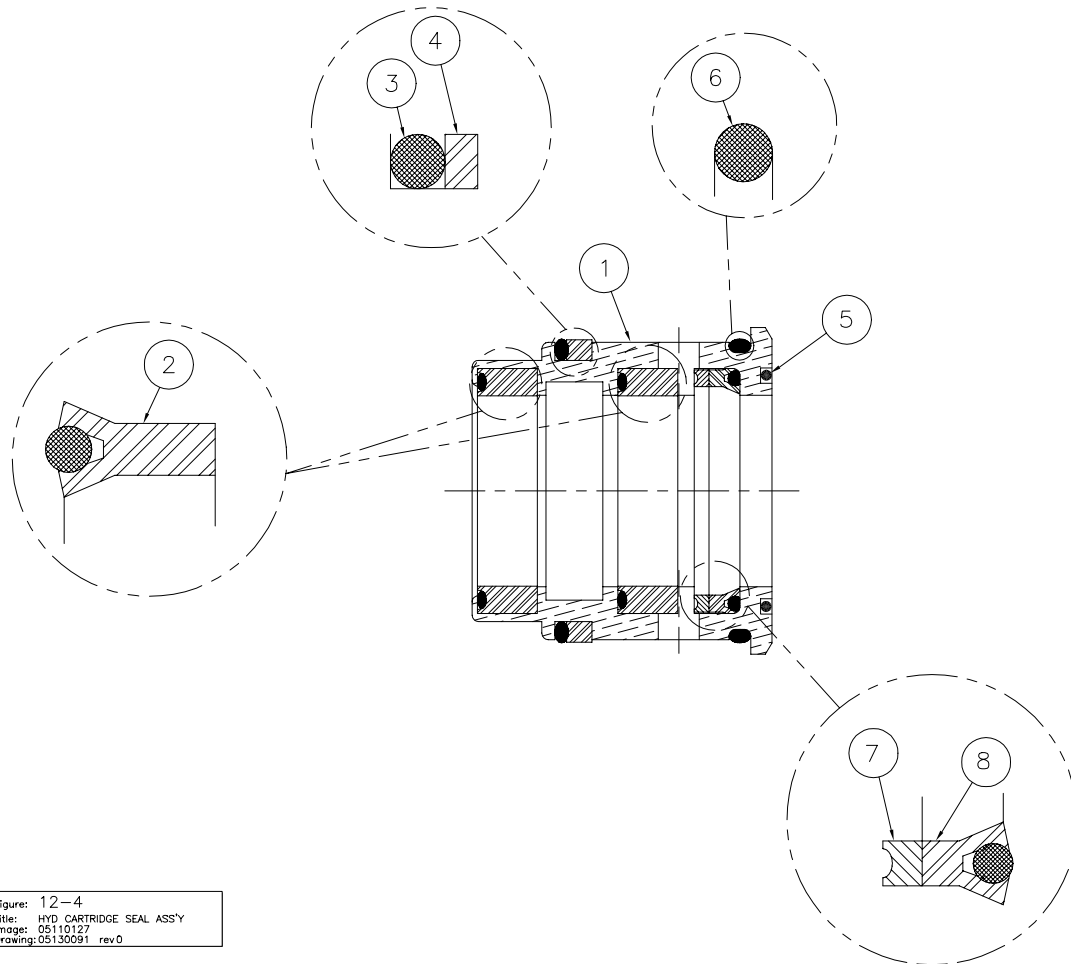

Figure: 12-4
Title: HYD CARTRIDGE SEAL ASS'Y
Image: 05110127
Drawing: 05130091 rev 0

Item Description

- | | | |
|--------------------|----------------|------------|
| (1) Cartridge Body | (2) U-cup Seal | (3) O-Ring |
| (4) Back-Up Ring | (5) O-ring | (6) O-Ring |
| (7) Back-Up Ring | (8) U-cup Seal | |

NOTE

It is important to examine the inside diameter surfaces of cartridge seal grooves for scratches, especially any scratches in the axial direction that might offer a leak path. Use caution during seal removal and installation to avoid scratching these surfaces. Do not use metal screwdrivers, wires, etc. to remove inside diameter seals. Plastic or wood should be used for seal removal and installation.

1. During seal installation, orient U-cup packing seals (2) (8) so that they match figure above.
2. Apply food grade grease to seals and cartridge seal components to aid in installation and seal seating. Use installation tool, if available, for installation of U-cup seals (2) (8). Verify that U-cup O-rings are in place in their respective U-cup seals after installation.

7.3.7 Hydraulic Piston

The hydraulic piston contains a seal assembly, bearing rings, pins and flat spring bands, and check valves. Bearing rings (10) provide wear contact between piston and cylinder ID. Plungers (12) are held in place by 6 each pins (2) per plunger. Pins (2) are maintained in place by flat steel band (6). Check valves (4) are mounted internal to the piston to vent unwanted hydraulic pressure to the piston opposite side. These check valves prevent hydraulic pressure from building behind the plunger button

Replace Piston Seal

1. Remove bearing rings (10) and worn seal ring assembly (9).
Do not scratch bottom surface of piston seal groove. Scratches to the seal groove sides and/or bottom can result in a hydraulic leak.

NOTE: Use a smooth, dull-edged blade made from brass or similar soft (relative to steel) material to remove and install seal assemblies.

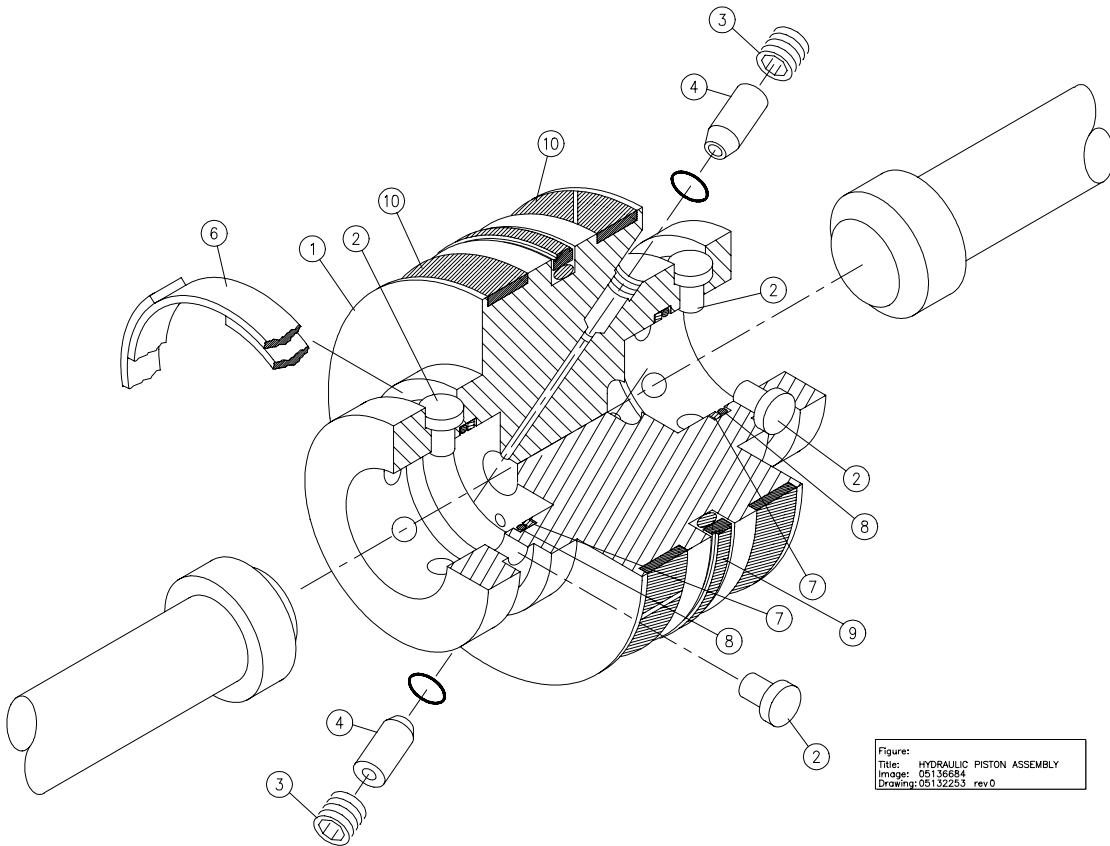

Figure:
Title: HYDRAULIC PISTON ASSEMBLY
Image: 05136584
Drawing: 05132253 rev 0

Item Description

1. Piston	5. Threadlocking Adhesive	7. Backup Ring (2 ea.)
2. Pin (12 Each)	6. Flat Wire Snap Ring (2 ea.)	8. O-ring
3. Set Screw (2 ea.)		9. Seal Assy
4. Check Valve (2 ea.)		10. Bearing Ring (2 ea.)

2. With seal and bearings removed, inspect seal groove bottom for marks or scratches and residue buildup. Clean and /or repair groove surfaces as required.
3. Install replacement bearing rings (10).
4. Install replacement piston seal assembly (9). First install inner ring, taking care that this ring is not twisted after installation. Slide outer seal ring over metal edges, easing seal into place over inner ring.

NOTE: Heating the piston seal ring in hot water (150 degree F for 3-5 minutes) increases seal flexibility.

Service Piston Plunger Sockets (2 each)

1. Remove flat spring bands (6) and remove plunger retainer pins (2). Inspect pins and spring band for deformation or unusual wear. Clean and inspect pin holes in piston for unusual wear or hole deformation/enlargement.
2. Remove plunger button O-ring (8) and backup ring (7) (2 places), taking care not to scratch or otherwise damage seal groove surfaces. Clean and inspect seal grooves for residue buildup or surface marks that might cause seal leaks.
3. Inspect plunger button sockets for unusual wear.

NOTE: Plungers may make an indentation in the bottom of the plunger socket. The bottom of this socket may show the impression of the plunger on it due to the high contact forces between piston and plunger. This compression mark is normal.

Service Piston Internal Check Valves

NOTE: Check valve (4) servicing is not necessary unless there is suspicion of a problem. If the check valves (2 each) or piston internal passages must be serviced, seal and pin servicing is also recommended.

1. Check valves (items (4), 2 each) or cross-drill plug (11) removal may be necessary. Re-install using thread locking compound applied sparingly on the plug threads.

Excess compound may clog a check valve or block a drilled passageway.

NOTE: To avoid excess compound, position the plug or retainer on its Allen wrench, apply thread locking compound, then hold the plug/retainer horizontal on a paper towel while rotating the plug/retainer to wipe off excess thread locking compound.

2. Install O-ring in check valve cavity, positioning in hole bottom with pencil-like blunt instrument. Install check valve with chamfered end toward O-ring. Coat retainer (3) with thread locking compound. Then thread retainer (3) over check valve cartridge (4). Allow 24 hours for thread locking compound to set.
3. Install plugs (11) in cross- drilled passages by applying thread locking compound to plug threads. Then thread plugs (2 each per hole), with the

second plug acting to lock in the first. Allow 24 hours for thread locking compound to set.

Install Plunger Button Seals and Retainer Pins in Hydraulic Piston

1. Install new backup ring (7) and O-ring (8) in each internal groove in each plunger pocket (2 places).

Failure to install backup ring can result in plunger being forced out of plunger pocket.

2. Reinstall pins in piston, verifying that each pin moves freely without excess side play in its cavity.
3. Reinstall band (6) over pins. Repeat this process for the opposite piston side. With piston on bench, install plunger in each end of piston, checking snap-in feature of plunger attachment. Use plunger removal tool to verify that pins retract (release plunger) and close (retain plunger) in a uniform manner.

Install Hydraulic Piston Assy into Hydraulic Cylinder

NOTE: Piston seal assembly must be compressed before the piston assembly will slide into the hydraulic cylinder. A ring compression tool such as shown in the figure below is recommended.

1. Check that hydraulic cylinder bore is free grit, or contamination, and that the proximity switches are removed to prevent interference. Lubricate piston bearing and seal surfaces with FML-2 grease. Lightly lubricate 2-3 inches of cylinder (15) bore with same grease.
2. Fit or drive piston assembly into ring compression tool (20). Position compression tool with piston assembly over end of hydraulic cylinder. Using a plastic-faced hammer so as not to damage piston surfaces, gently drive the piston assembly into the hydraulic cylinder.
3. Remove seal compression tool, continue driving piston assembly into hydraulic cylinder until it is between the proximity switch holes. Continue intensifier re-assembly by installing cylinder heads, plungers, hydraulic seal cartridges, and HP components.

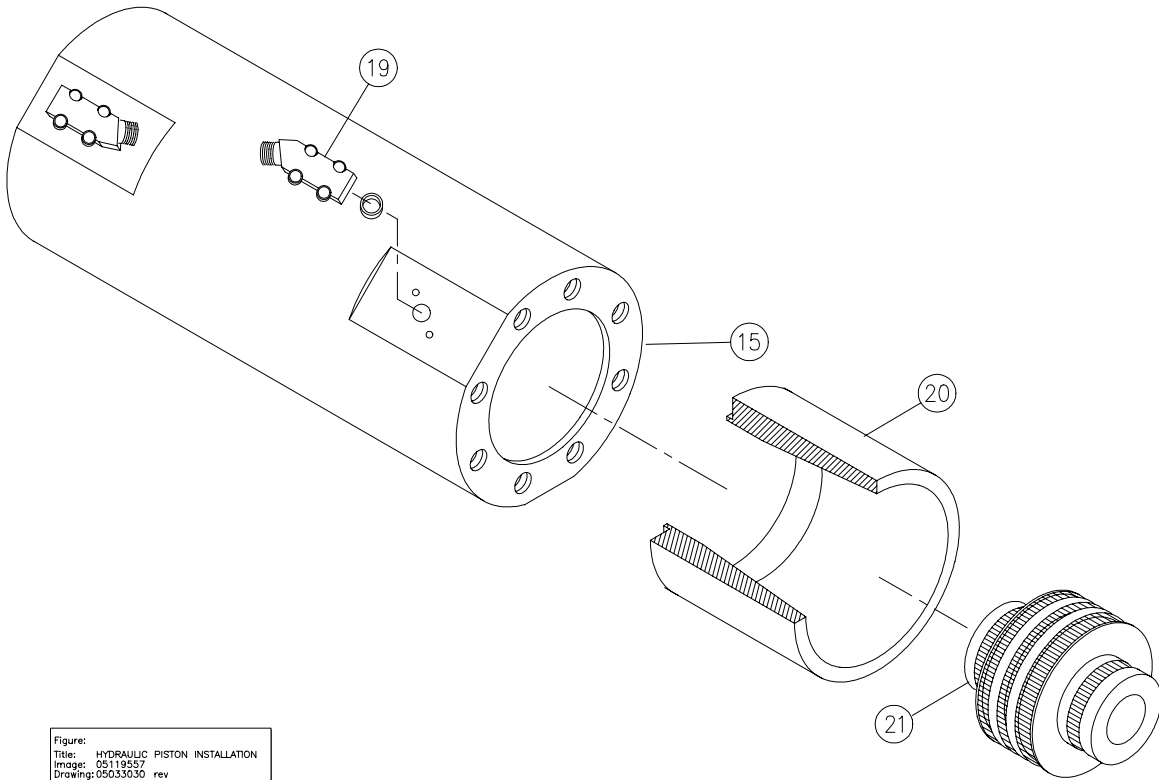

Figure:
Title: HYDRAULIC PISTON INSTALLATION
Image: 05119557
Drawing: 05033030 rev

Item Description

- | | |
|------------------------|---------------------------------------|
| 15. Hydraulic Cylinder | 20. Seal Ring Compression Tool (P460) |
| 19. Proximity Switch | 21. Hydraulic Piston Assy |

7.3.8 Hydraulic Cylinder

The inside diameter surface of the hydraulic cylinder should be inspected for wear grooves and surface finish whenever the hydraulic cylinder heads are removed. Excessive grooving on this bore is indicative of piston seal wear.

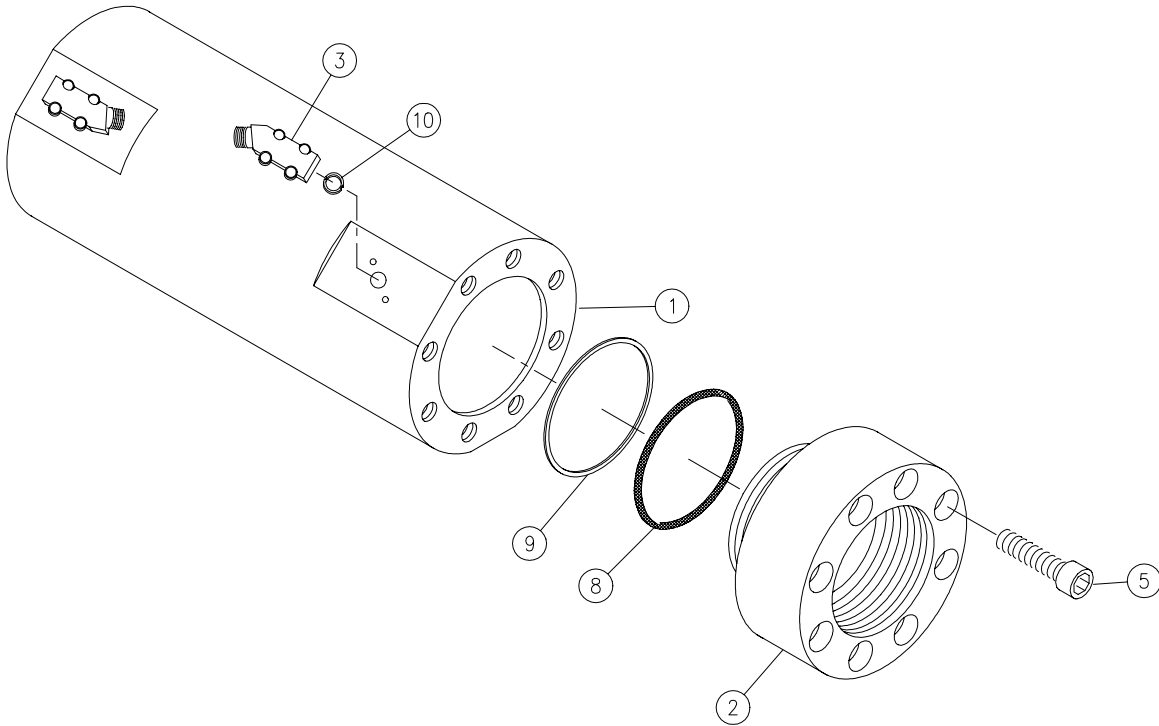

Image: 05114707
Drawing: 05113030 rev

Item Description

(1) Hydraulic Cylinder	(2) Cylinder Head	(3) Proximity Switch
(5) Cap Screw	(8) Back-up ring	(9) O-ring
(10) Spacer		

7.4 HP Dump Valve

The dump valve assembly includes a normally open HP water valve, plus a solenoid operated air valve for the air actuator on the dump valve. Replacement parts for the HP valve are provided in the **Parts Lists** (Section 12, see Figure 12-7, “Bulkhead Piping Assy”).

7.5 HP Attenuator

There is no servicing of the HP attenuator at the customer level. The seals in the HP attenuator are tested at Ingersoll-Rand to high pressure in excess of operating pressure making disassembly difficult. In the event of a HP water leak of a HP attenuator, the attenuator should be replaced. The defective attenuator should be returned to KMT Waterjet for replacement or servicing.

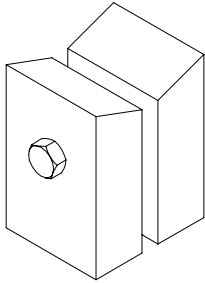

VEE BLOCK CRADLE
05149877

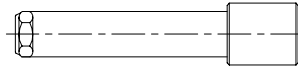

PLUNGER REMOVAL TOOL
05004924

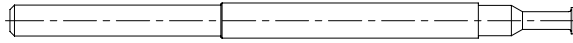

SEAL REMOVAL TOOL
10148674

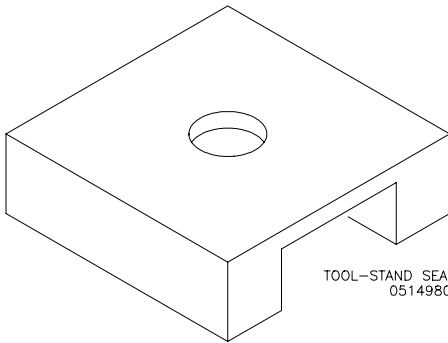

TOOL-STAND SEAL REMOVAL
05149802

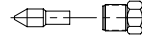

3/8" PLUG
10079523



3/8" GLAND
10078129

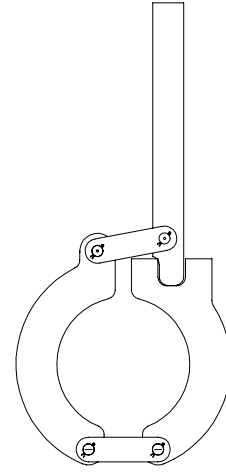

CYLINDER WRENCH
05066139

Figure:
Title: S14 INTENSIFIER HP CYL TOOLS
Image: 49831951
Created: rev

Section 8 ELECTRICAL SYSTEM**8 Electrical System**

The electrical system contains all functions necessary for turnkey operation. This includes the control and starter panel, intensifier reversal circuit, diagnostics, malfunction warning and protection.

The electrical enclosure and the display, buttons, lights, and electrical harnesses into and out of this enclosure can be exposed to occasional water spray and dust per NEMA-12 standards.

8.1 Electrical Overview

There is only one electric motor on the SL-IV Waterjet Pump. The control voltage of 24vdc is furnished by the built-in power supply drawing its power from the motor's AC circuit.

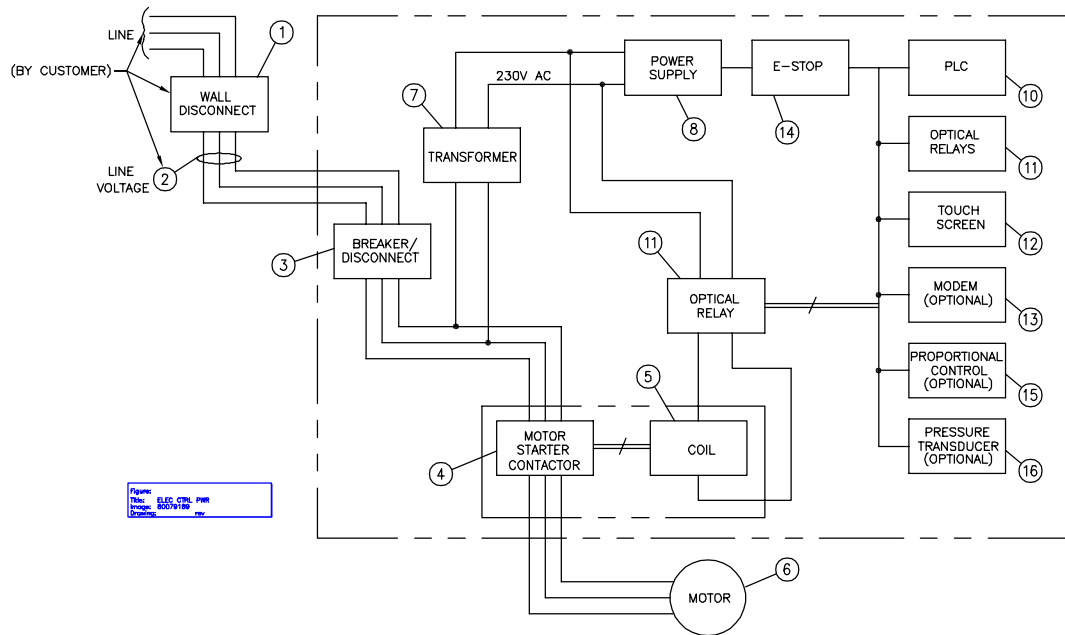

Figure 8-1 ELECTRICAL CONTROL POWER

Item Description

1	Wall Disconnect-Main Power	10	Programmable Logic Controller
2	3-Phase Line (Service Drop) Power	11	Optical Relays
3	Enclosure Door Disconnect/Circuit Breaker	12	Touch Screen Interface Panel
4	Motor Starter Contactor(s)	13	Modem (Optional)
5	Contractor Coil(s) (230V)	14	Emergency Stop Button
6	Electric Motor	15	Proportional Control (Optional)
7	Transformer (230V AC Out)	16	Pressure Transducer (Optional)
8	Power Supply (24V DC Out)		

8.1.1 Motor Starter Circuit

All horsepower levels of SL-IV Waterjet Pumps are available with built-in starter/ control panels . Two starter circuits are typically used:

- ◆ Wye-Delta for reduced voltage starting: Required in Europe and standard on the SL-IV for motors of 75 hp or greater. Three each 3-phase contactors are used to accomplish Wye- Delta starting.
- ◆ Across- the- Line, or Full- Voltage starting: Commonly used in North America, only a single 3-phase contactor is required.

Electrical power from the utility grid enters the SL-IV Intensifier Pump at the combination circuit breaker/ disconnect (3). Note that whenever the door to the electrical enclosure is opened, all electrical power is automatically disconnected from the intensifier pump. Be aware that 3-phase, medium voltage power is still present at the input side of the main circuit breaker/ door disconnect. To make the SL-IV Intensifier Pump electrically safe, one should switch the wall disconnect (1) OFF and observe LOCK-OUT/ TAG-OUT safety practices. Note that the wall disconnect (1) should have circuit breakers or fuses, but that this over current protection may be oversized for the current draw of the particular SL-IV Intensifier Pump. The primary over-current protection for the SL-IV Intensifier Pump is the main breaker/ door disconnect (3) built into the electrical enclosure. On the output side of the main breaker/ door disconnect (3) main power leads connect to the motor starter contactor(s) (4), then to the electric motor (6). Secondary power leads connect to two phases of the main breaker/ door disconnect output side to supply the control circuit.

Other features included in the motor starter circuits include:

- Manual disconnect with door handle interlock
- Overcurrent protection
- Hydraulic unloading during startup, allowing the motor to reach full speed.
- 9-post motor terminal block for European models.

8.1.2 Control Circuits and Logic

The operator controls the waterjet pump primarily through the digital display panel. The digital interface (display) communicates with the PLC controller located inside the electrical enclosure.

In order to avoid costly damage to the pump, automatic shutdown logic and diagnostic messages are displayed to the operator as to the cause of the impending shutdown. The inputs that trigger automatic shutdown are:

- Motor Overload
- Motor Feedback Failure
- Oil Level Low
- Oil Temp High
- Low Booster Pressure
- Low Inlet Water Pressure
- Long Idle Time Shutdown
- Booster Temp High
- Left Overstroke Shutdown
- Right Overstroke Shutdown
- Topworks Overstroke Shutdown

For more information on these conditions and recovery procedures, refer to **Section 3, Operation**, of this manual.

The functions listed below are available by connecting to terminal blocks in the starter/control enclosure. An optional 37-pin circular connection mounted in the side of electrical enclosure is available.

- Start
- Stop
- Emergency Stop (E-Stop)
- Pump RUN indicator light
- Pump malfunction light
- Remote 2-pressure
- Proportional Pressure (optional)

Table 8-2. SENSORS/SOLENOIDS - SLIV

No.	FUNCTION	COMPONENT DESCRIPTION	LOCATION
1	Intensifier shift sensors	Proximity switches	Hydraulic cylinder, intensifier assy
2	Cutting water supply	Solenoid shutoff valve, water	Bulkhead plumbing assembly
3	HP water dump valve	HP shutoff valve, pneumatically-operated, solenoid valve (pneu)	HP discharge piping, betw. HP atten. and bulkhead piping.
4	Intensifier Shift, A/B Port Shifting	Solenoid- operated, directional control valve (DCV), hydraulic pilot- operated spool	Hydr manifold assy, motor/ pump group
5	HI/LO Pressure Select	Solenoid shutoff valve, hydr cartridge style	Hydr manifold assy, motor/ pump group
6	Low oil level/ temperature	Combination level/ temp switch, immersed in hyd fluid	Hydraulic reservoir
7	High Booster Pump Temp	Temperature sensor	LP water filter assy, manifold block
8	Low cutting water supply pressure	Pressure switch, 30 psig	LP water filter assy, manifold block
9	Low booster pump pressure	Pressure switch, 60 psig	LP water filter assy, manifold block

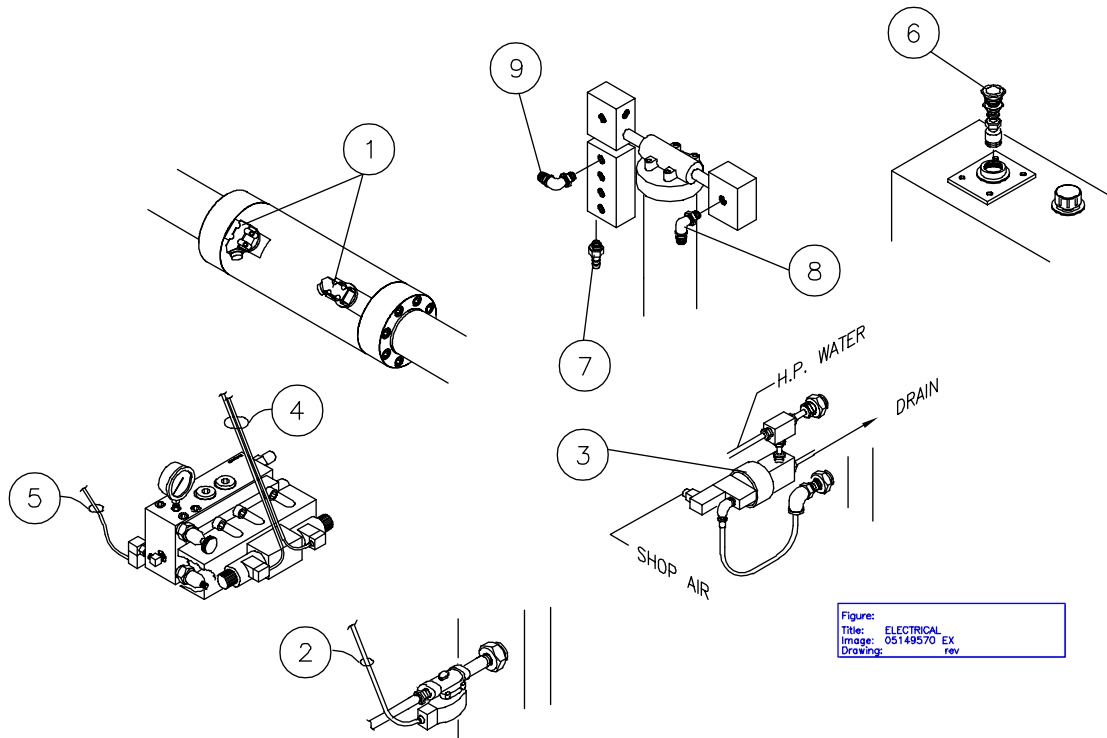

Figure:
Title: ELECTRICAL
Image: 05149570 EX
Drawing: rev

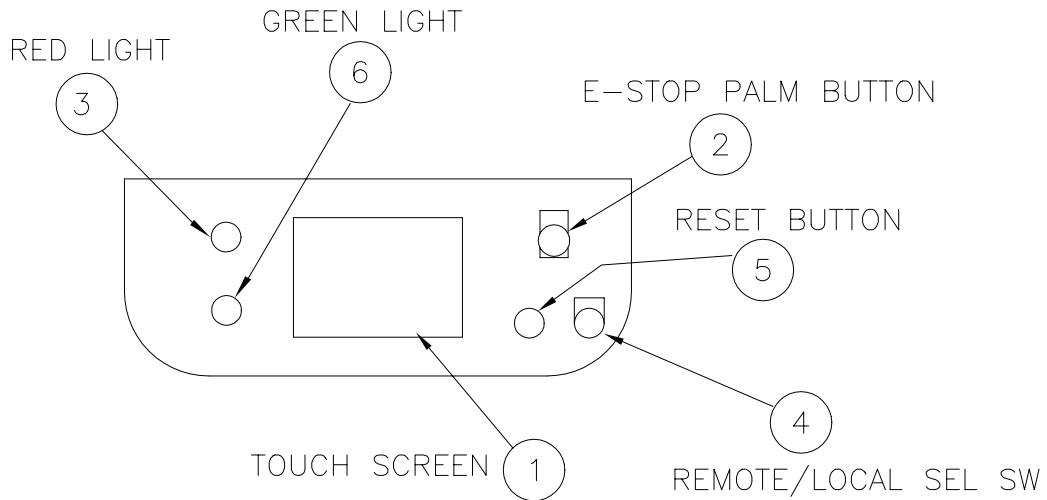

Figure:
Title: CONTROLS
Image: 05146337 EX
Drawing: rev

Figure 8-3 CONTROL PANEL/SCREEN, SLIV

8.1.3 Operation (See Figure 8-3)

To energize the Control Panel, pull the **EMERGENCY STOP** button, then press the **RESET** button. The Control Panel will display the **RUN** screen. After a five second delay, if all run conditions are met (no alarm conditions, and inlet water pressure above 30 psi) the **RUN BAR** will flash, indicating machine is ready to start.

Before starting intensifier insure all parameters are set to users specifications.

On **RUN** screen press **PRESSURE** button to set final pressure. An up/down arrow below the **PRESSURE** switch indicates high or low pressure setting. The pump will be held in low pressure for 20 seconds after motor is started, after which pressure will go to high if high is selected, otherwise the pump will stay in low pressure. The final pressure may also be set on the **PRESSURE CONTROL** screen if analog control is present.

On the **STROKE RATE** screen set the **STROKE RATE ALLOWED**. Because overstroke protection is related to stroke speed under actual pressure setting, this allows you to control sensitivity of the overstroke protection software for your particular operating pressure.

Return to the **MAIN MENU**. Scroll to **SET-UP** screen. There are two **SET-UP SCREENS** – If analog pressure control is not installed on the machine, a screen will appear that does not include the **TRANSDUCER** and **PROPORTIONAL SELECT** buttons. These buttons are used only if a pressure transducer and/or a proportional valve are installed on the machine. Set water reset function and idle shutdown function on or off.

WATER RESET FUNCTION

Press on **(I)** to shut water off five (5) minutes after machine shuts down. Selecting this function will insure that the inlet cutting water is shut off following a shutdown fault. This can prevent water from leaking past a damaged water seal following an overstroke shutdown caused by a seal failure.

IDLE SHUTDOWN FUNCTION

Set timer to stop machine after 5-30 minutes of inactivity (machine not stroking). This feature saves energy by automatically shutting down the intensifier if it is not being used.

For more information, refer to Section 3, **Operation**, of this manual.

(1) Standard machine, start-up after machine has been E-stopped:

Safety dump valve will be open. It will close 3 seconds after the T/W begins stroking. The pump will be held in low pressure for 20 seconds after motor is started after which pressure will go to high if high is selected, otherwise will stay in low.

The purpose for this is to allow entrapped air to be bled from any HP cylinder that has been maintained to avoid hot air burning the plunger seals.

(2) Standard machine, start up after normal stop: Safety dump valve will be closed, pump will be held in low pressure for 20 seconds after motor is started, after which the pressure will go to high if high is selected, otherwise will stay in low.**(3) Machine equipped with hp transducer, start up after E-stop:** same as (1) above.**(4) Machine equipped with hp transducer, start up after normal stop:** If pressure is allowed to bleed through orifice to below 1000 psi, dump valve will open and start up will be like (1) above, if pressure is not allowed to bleed, start up will be as (2) above.

- The display screen will always default to the **Run** screen after being on any other screen more than 5 minutes.

NOTE

The high-pressure dump valve will not close if the air supply is OFF.

After pressing the Start button:

- The motor starter in the control panel is activated and the motor starts.
- The intensifier assembly starts operating. Reversal position is sensed by proximity switches, which send signals to the PLC inside the control panel. The PLC activates the opposite solenoid on the pump reversing valve.

8.1.4 CONTROL POWER CIRCUITS (see Figure 8-1)

A control power transformer (7) with multiple input taps and 230 VAC output taps provides all control power to the SL-IV Intensifier Pump. A pair of leads from the main breaker/ door disconnect (3) are routed to the transformer (7) input side. Note that transformer (7) input voltage should match voltage at the wall disconnect (1). Hence, the 2 leads to the transformer (7) input are correct when L1 is 0 volts and L2 matches the wall disconnect (1) voltage (e.g., 460, 415, 757, 400, 208 volts-AC, etc.).

Transformer (7) output power is always 230 volts-AC. Note that if the Pump has a 230 volt AC motor (6) and starter (4) setup, no transformer (7) is necessary. (IR Waterjet does NOT recommend that Pumps be operated at 230 volts-AC for reasons of operating cost and energy savings, though sometimes running the intensifier at this and other low voltages is necessary.)

Wiring from the control power transformer (7) output (secondary windings) is directed to two places: 1) motor contactor(s) (5) and 2) 24 volt-DC power supply (8). To minimize the load requirement on the 24 volt-DC power supply, motor contactor coil(s) (5) use 230 volt-AC coil(s), while the relay logic (11) controlling the motor contactor(s) (4) is powered by 24 volts-DC.

The 24 volt DC power supply (8) receives 230 volts-AC input power and regulates it to 24 volts DC, 5 amps maximum output power. 24 volt-DC power from the power supply (8) first passes through a circuit breaker and the EMERGENCY STOP (E-Stop) (14) logic, then to the PLC (10), the touch screen display (12), the optical relays (11), and to other control functions.

8.1.5 (OPTIONAL) PROPORTIONAL PRESSURE CONTROL

Proportional pressure control (optional) allows the operator to change cutting water pressure using the touch screen. An electronically-controlled hydraulic cartridge relief valve mounted on the hydraulic manifold accomplishes this proportional control. The proportional relief valve receives its commands from a section of the PLC. An analog output module attachment with the PLC is required to operate the proportional pressure control.

8.1.6 (OPTIONAL) MODEM

Modem option available for remote maintenance, trouble-shooting and software updating.

8.2 Maintenance Overview

Electrical components require minimum attention and service. The components that require service are the proximity switches on the intensifier assembly, and the optical relay switch in the control panel.

8.2.1 Proximity Switch Service

If the pump quits pumping water, the proximity switch may need to be replaced. Check the LED lights on the switch.

Symptoms of a failed proximity switch are (1) the LED lights do not change state (indicating not sensing the piston) or (2) the LED lights are continuously flashing. Replace the switch when failure occurs.

- Components:** (1) Intensifier Assembly
(2) Piston
(3) Proximity Switch
(4) Hydraulic Cylinder
- Recommended Tools:** Allen (hex) Wrench, M5
Torque Wrench
Rags
- Parts:** Proximity Switch

Replace Proximity Switch

1. Turn off waterjet pump, disconnect and LOCKOUT electric power.
2. Disconnect cable.
3. Unscrew bolts, remove proximity switch.
4. Install new switch. Install bolts.
5. Torque bolts to 16-18 Nm (140-160 in-lbs.).

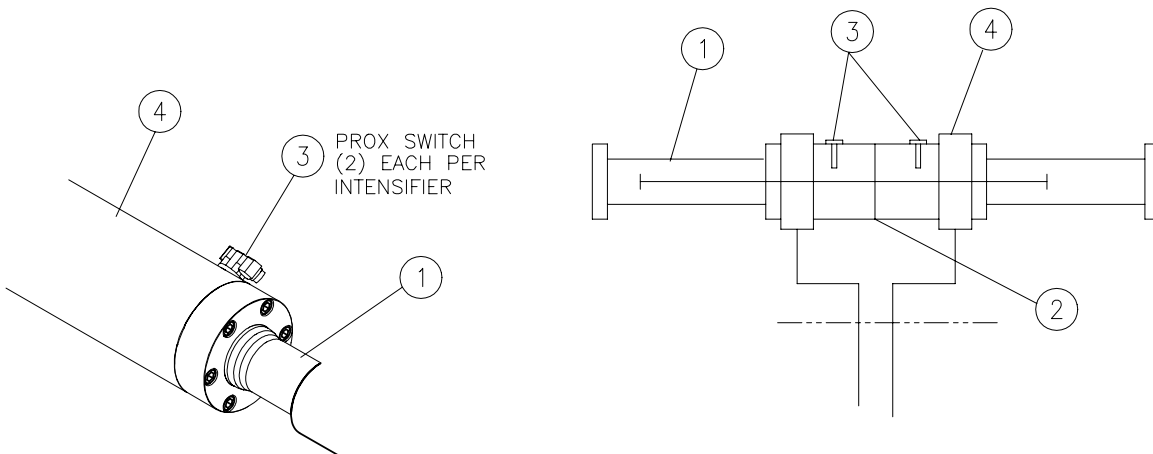

Figure:
Title: PROX SWITCHES
Image: 80079197
Drawing: rev

8.2.2 Optical Relay Switch Service

Components:	Optical Relay Switch
Recommended Tools:	Flat screwdriver, 3mm (1/8 inch)
Parts:	Optical Relay

Replace Optical Relay Switch

1. Turn off waterjet pump, disconnect and LOCKOUT electric power.
2. Open control panel.
3. Unscrew optical relay switch mounting bolts, remove and replace.

If the motor will not start and a “motor feedback” fault message appears, the optical relay which controls the motor starter may need replaced.

9 Features

In addition to “slow start”, other features of the hydraulic system are listed below:

- **Hydraulic 4-way valve** – directional control valve (DCV)–solenoid–operated. Used for HP cylinder shifting.
- **Reference hydraulic gage** – used for adjusting pressures in the HI/LO relief valves. Displays hydraulic pressure, as well as water pressure in multiple units directly at the pressure adjustment knob.
- **Built in hydraulic oil drip pan** – allows for the spills to be contained within the machine while addressing environmental issues of mixing water and oil.
- **Remote dual pressure control** – allows for flexibility at the cutting nozzle in pressure adjustments for certain pure water/abrasive applications.
- **Pressure adjustment control** – allows for infinite pressure settings though out the entire pressure range for flexibility.

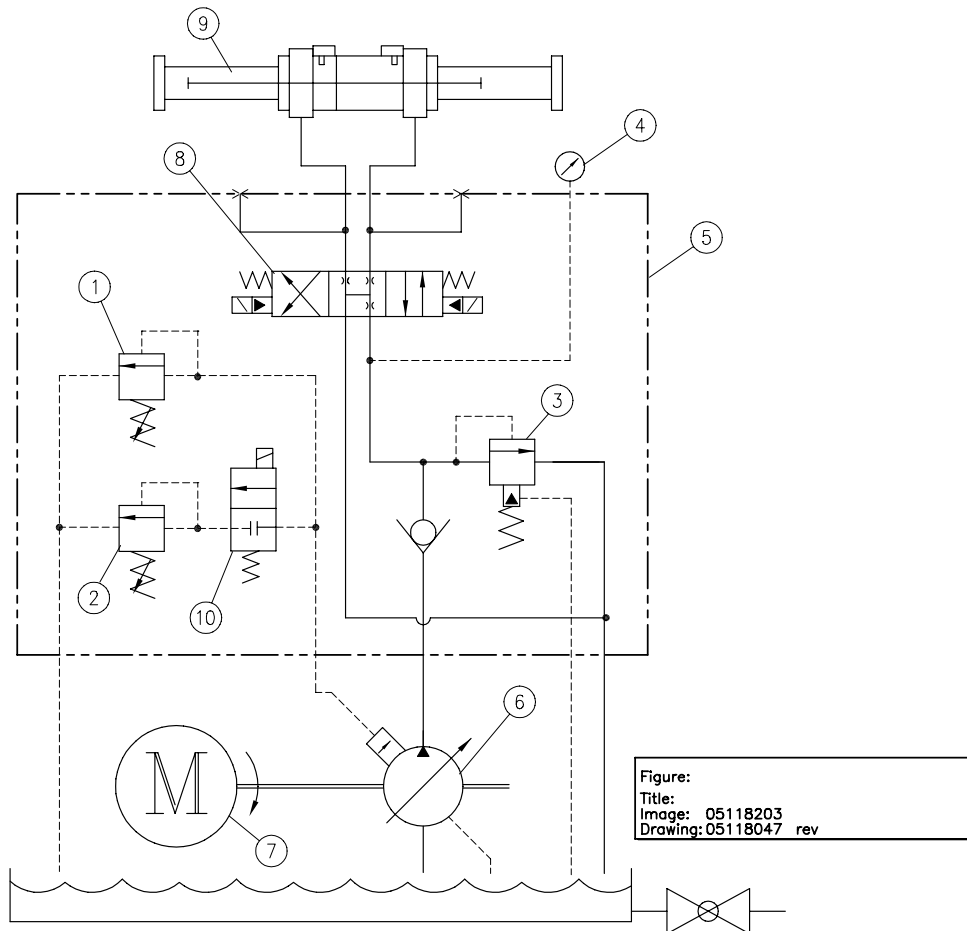

9.3 Components

Following are the hydraulic system components:

NOTE

The main pump is direct-mounted to the motor. The main pump control includes hi and lo preset pressures. The operator is able to switch between pressures at the operator's console.

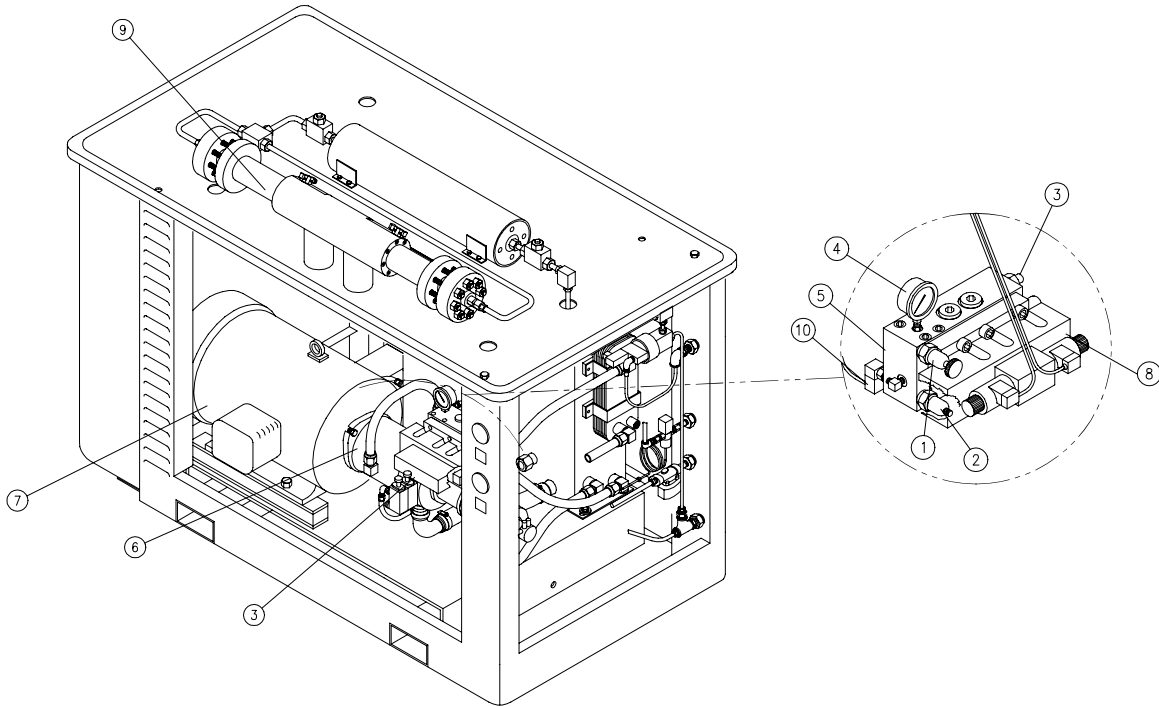

Figure:
Title: HYDRAULIC SYSTEM
Image: 80073489
Drawing: 80072648Rev

Item Description

- | | | |
|---------------------------|-------------------------------|------------------------|
| (1) HI pressure control | (2) LO pressure control | (3) Fixed relief valve |
| (4) Gage | (5) Manifold | (6) Pump |
| (7) Motor | (8) Directional Control Valve | (9) Hydraulic Cylinder |
| (10) Hi-Lo Solenoid Valve | | |

9.2 Operation

The hydraulic system operates at HI (high) or LO (low) pressure settings up to the maximum flow capacity of the variable displacement piston pump. Upon selecting HI or LO, the operator is able to adjust the HI or LO pressure controls within the respective adjustment ranges.

The electric motor (7) drives the variable displacement, pressure compensated pump (6). The hydraulic manifold (5) is mounted on the pump discharge. The flow from the pump passes through check valve to the directional control valve (8), and the directional control valve sends the flow to the hydraulic cylinders (9) in one direction until the piston activates the proximity switch at the end of the stroke. The activated proximity switch sends an electrical signal to the programmable controller (PLC). This PLC in turn activates the directional control valve

(8) to change flow and to reverse direction of movement of piston until activating the opposite end-of-stroke proximity switch.

9.2.1 Hydraulic Pressure Adjustment

A variable displacement pressure compensated feature maintains constant operating pressures even under variable flow demands. Dual pressure control is standard. Switching high to low pressure may be done at the control panel (or remotely) with the HI-LO switch that activates the solenoid valve (11). The HI pressure is set by adjusting the knob and the LO pressure is adjusted using a wrench on that relief cartridge (2). Turning the knob/adjusting the screw clockwise increases pressure.

NOTE

In order to remote select the pressure, the HI-LO switch should be set to the "HI" position.

9.2.2 Hydraulic System Pressure Protection

Besides the HI-LOW Pressure Control Valves, the hydraulic system pressure is limited by the main relief valve (3). The operating hydraulic pressure is indicated by hydraulic gage (4).

Control	Valve	Pressure Adjustment		Hyd. Pressure Bar (psi)	
		Increase	Decrease	Maximum	Minimum
High Pressure	1	Clockwise	Counterclockwise	207 (3,000)	1.7 (25)
Low Pressure	2	Clockwise	Counterclockwise	103 (1,500)	1.7 (25)
Main Relief	3	Fixed	Fixed	234 (3,400)	(Not applicable)

NOTE

Do not adjust the HI pressure control to pressures greater than 207 bar (3,000 psi). Doing so will cause the main relief to open limiting hydraulic pressure to 234 bar (3,400 psi). Also due to excessive opening of the main relief valve will result in significant wasted heating of the hydraulic oil, and the decrease of water flow performance.

9.3 Motor/Hydraulic Service Maintenance

The hydraulic oil filter should be checked daily and replaced if the pressure gage reads over 40 psi. The hydraulic oil should be replaced every 2000 hours or yearly, whichever occurs first. For hydraulic oil and filter maintenance, see Section 10, **Recirculation System**.

The hydraulic system components that require periodic maintenance are the motor and the manifold. The motor needs to be serviced every 5000 hours of use. The operating pressure settings of the manifold needs to be checked daily and adjusted if necessary.

Recommended Tools: Manual Grease Gun
Open End Wrench 14mm (9/16")
Rags

Parts: Bearing Grease, SRI #2 or equivalent

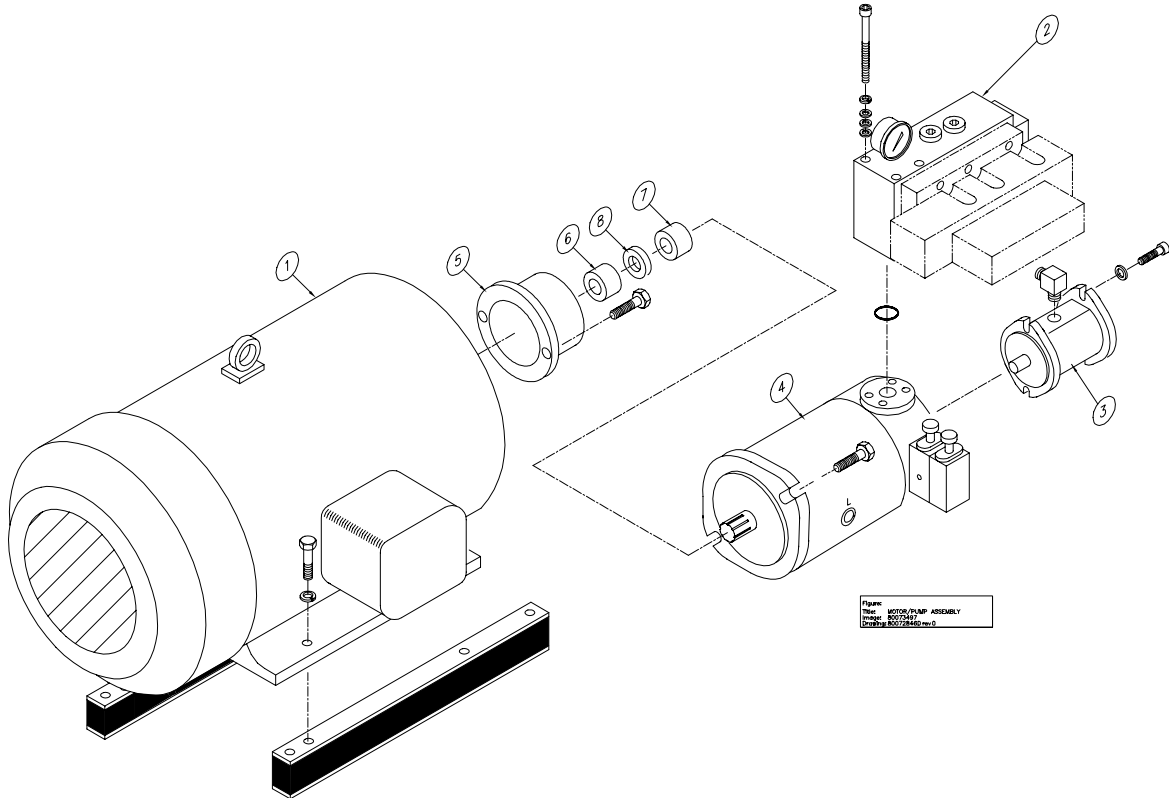

Item Description

(1) Motor	(2) Manifold	(3) Recirculation Pump
(4) Hydraulic Pump	(5) Housing	(6) Motor Coupling
(7) Pump Coupling	(8) Soft Coupling	

9.3.1 Motor Service

1. Locate the two zerck fittings, they are located at each end of the motor, remove their plastic caps.
2. Apply one or two strokes of grease. Replace caps on zerck fittings.
3. Run motor a few minutes.

9.3.2 Manifold Service

1. Check operating pressure.
2. If pressure adjustment is necessary:
3. Adjust high pressure control valve. Turn locking nut counterclockwise, then turn the knob clockwise to increase pressure, counterclockwise to decrease.
4. Adjust low pressure control valve. Turn locking nut counterclockwise with open end wrench. Turn the hex clockwise to increase pressure, and counterclockwise to decrease. Lock in place with nut.

- **9.3.3 Motor/ Pump Coupling**

1. Remove access cover on item (5). See Section 12 “Motor Pump Assembly” for soft coupling part number information.
2. Remove pump assembly items (2, 3, 4 etc).

NOTE: Pump shaft must be moved backwards approximately 1.00 inches. Support pump assembly with wood blocks, remove mount screws, attempt to move pump assembly without removing attaching hoses.

3. Remove soft coupling (8). Inspect for damage to metal coupling halves (6) and (7).
4. Install replacement soft coupling (8).
5. Slide pump assembly into soft coupling, install mounting bolts re-attaching main pump (4) to housing (5).
6. Inspect soft coupling for proper fit, then replace access plate on housing (5).

Section 10 RECIRCULATION SYSTEM**10 Recirculation System**

The recirculation system keeps the hydraulic oil at operating temperature while using the minimum amount of cooling water flow. The system also provides the necessary oil conditioning and filtration to maintain oil cleanliness. The conditioning of the hydraulic oil includes cooling it, cleaning it, and together with the hydraulic tank, removing air bubbles entrained in the oil due to agitation and turbulent flow in the main pump circuit.

10.1 Components

The cooling and filtration system (recirculation system) is equipped with the following:

- **Recirculation pump** (gear-type)–which receives oil from the oil tank
- **Heat exchanger** - cooling water is controlled by the water modulating valve
- **Oil filter assembly** - includes a gage to show the filter element condition. It also includes a bypass or relief valve, should the filter element be allowed to become entirely clogged with dirt/contaminants.

10.2 Operation

The recirculation pump (1) takes oil from the tank (6) and pumps it to the oil to water heat exchanger (3), then to the oil filter (5) and back to the tank.

Condition of the hydraulic filter is determined by analyzing gage pressure. It should be read when both the water jet pump is running and the oil temperature is approximately 115°F. Oil fill port must be used when pumping oil into tank to assure cleanliness. By filling at this point, the hydraulic oil must pass through the hydraulic filter to get to the hydraulic tank, guaranteeing that the oil into the tank gets at least one pass through a good filter.

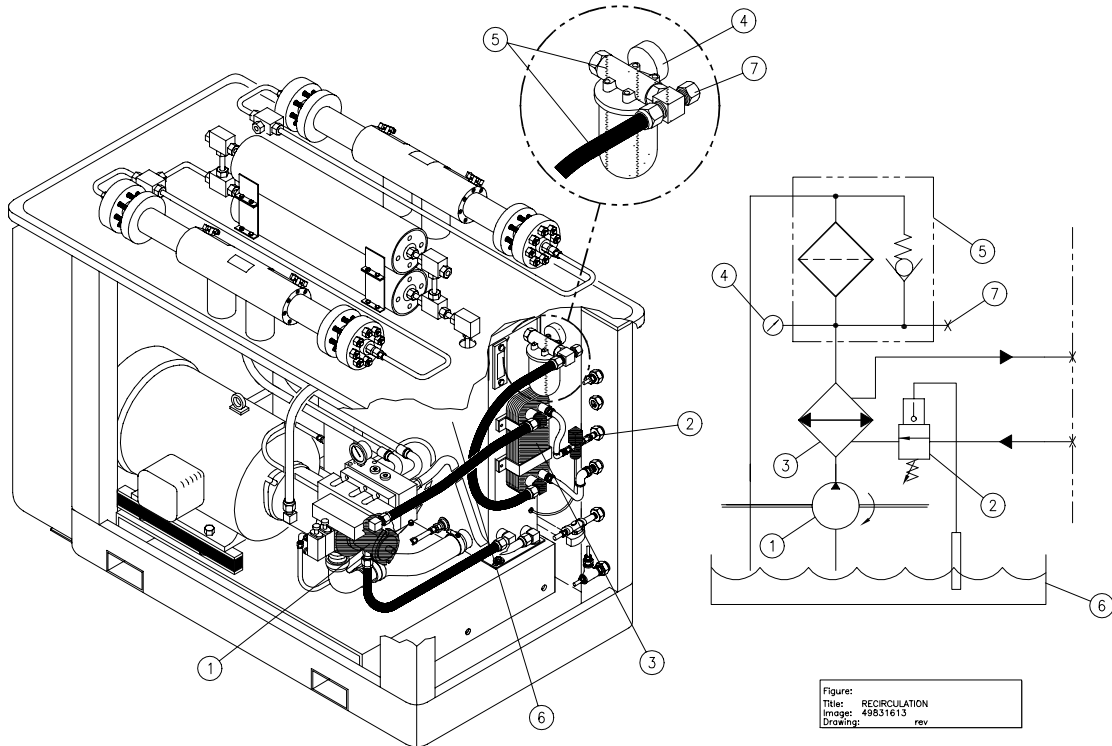

Figure: RECIRCULATION
Title: 49831613
Image: rev
Drawing: rev

Item Description

- | | | |
|------------------------|----------------------------|------------------------|
| (1) Recirculation Pump | (2) Water Modulating Valve | (3) Heat Exchanger |
| (4) Pressure Gage | (5) Oil Filter | (6) Hydraulic Oil Tank |
| (7) Oil Fill Cap | | |

Operating Temperature Adjustment

The operating temperature is adjusted by turning the water modulating valve (2) adjusting knob with a flat blade screwdriver. Clockwise increases the oil temperature.

The water modulating valve regulates the cooling flow that enters at port “D” to the heat exchanger (3) and then discharges through port “C” to the drain.

The operating oil temperature is factory set at 46°C (115°F) based on the temperature and flow of cooling water at the factory. Field adjustment may be necessary.

10.3 System Pressure Protection

System pressurization over 4.2 bar (60 psi) is prevented by a relief valve located on filter head (5).

Control	Valve	Adjustment		Setting	
		Increase	Decrease	Maximum	Minimum
Oil Temperature	2	Clockwise	Counter-clockwise	52°C (125° F)	41°C (110°F)
Oil Pressure	8	Fixed	Fixed	4.2 bar (60 psi)	3.8 bar (55 psi)

10.4 Maintenance Overview

During normal operating condition, the oil will be maintained at the correct operating temperature.

In order to get the best value from the hydraulic system (including the recirculation system) one should change the filter element when it indicates that it is time. The hydraulic oil should be changed at intervals recommended in the scheduled maintenance table, section 4.1 or whenever a fluid sample indicates that it is contaminated and beyond being fixed by simply operating the filter.

Parts: Hydraulic Oil:
 General service, use Mobil #DTE Heavy Medium, No. 021029 (Part 05022702)
 Food service, use Conoco AA-20 (Part 49835762)
 Oil with additives such as zinc diophosphate for antiwear are not recommended because of reaction with water.

Tools: Open End Wrench, 1-1/4"
 Rags
 Container to collect oil
 Oil transfer pump with 3/4" hoses. Inlet hose with 1/2" male pipe connector, and pump discharge hose with 3/4" female JIC connector.

Oil Filter

Replace filter element when the pressure reading is 1.4 bar (20psi) above normal when at operating temperature. Maximum normal pressure is 1.7 bar (25psi).

Components: (1) Oil Filter Head
(2) Element
(3) Pressure Gage

Parts: Element

Tools: Filter Wrench
Rags
Container to collect oil spills

Replace Oil Filter

1. Unscrew element from filter head with the filter wrench.
2. Oil gasket of new element.
3. Screw new element on head.
4. Start pump and check for leaks.

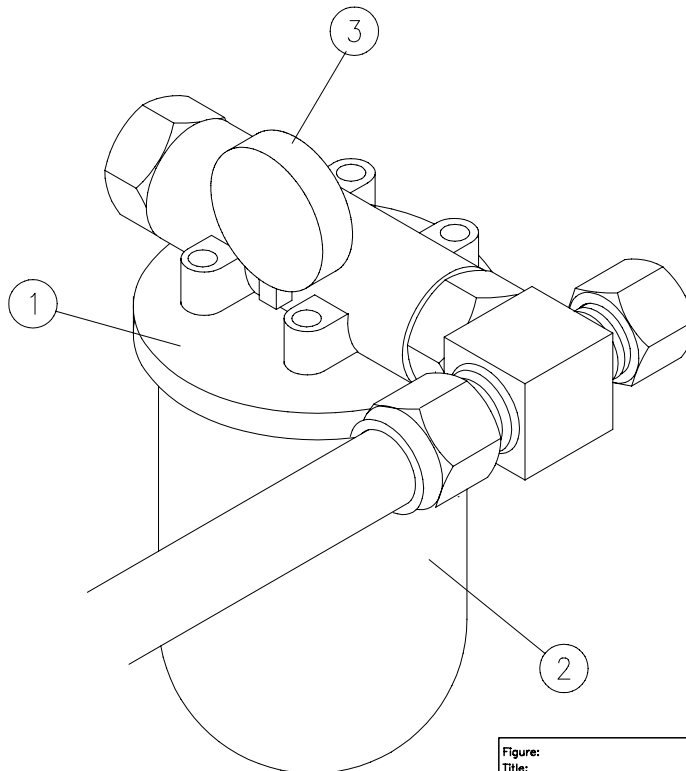

Oil Tank

The oil tank is equipped with the following:

- Visual temperature and level indicator
- Air breather and filter that prevents dirt from being sucked into the tank whenever the oil level drops, then allows air to escape when the level rises
- Drain valve, and
- Fill components.

The fill components consists of the Oil Filter Head, Fill Port, and the Fill Port Cap.

The breather is not a fill component, and must not be used as a fill point.

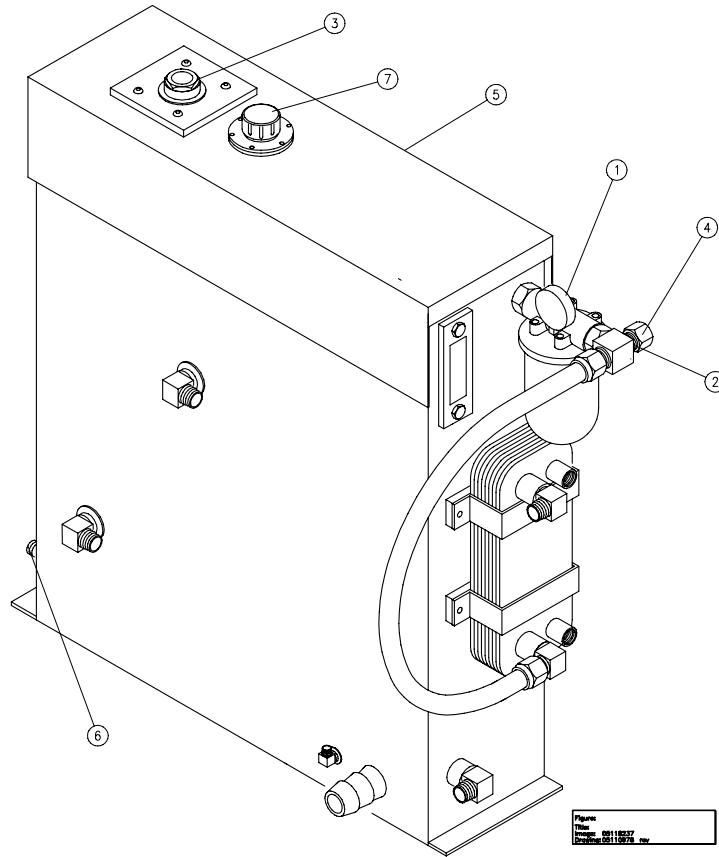

Item Description

- | | | |
|-----------------------|--------------------|------------------------|
| (1) Filter Assembly | (2) Oil Fill Port | (3) Temperature Sensor |
| (4) Oil Fill Port Cap | (5) Oil Tank Cover | (6) Shut-Off Valve |
| (7) Breather | | |

Replace Hydraulic Oil

1. Drain the tank, by connecting the inlet hose of the oil transfer pump to the drain valve. Open valve and pump oil to container.
2. Close hand valve, remove oil transfer pump inlet hose from hand valve.

NOTE

Never assume a new drum of oil is free of damaging contaminants. Typically, oil from a new drum does not meet the hydraulic system cleanliness requirements. For this reason it is important to use the oil transfer pump, which forces oil through the return filter into the tank.

3. Remove cap from fill port.
4. Connect oil transfer pump discharge to fill port. This will assure clean filtered oil is pumped into the tank.

**CAUTION**

Oil must be filtered through an equivalent filter such as a 10 micron filter element or see filter element in figure 12 in section 12. Failure to do so will cause damage to the primary hydraulic components, voiding the warranty.

5. Check oil sight gage to assure proper fill level. Remove hose, cap fill port.
6. Remove the plug of the main hydraulic pump case and make sure the case fills with oil. With the plug removed, head pressure from the tank (reservoir) will force oil into the pump case.
7. Run pump following initial start-up procedure. This will assure the system is filled.
8. Check oil sight gage. Add oil if necessary.
9. Disconnect oil transfer pump discharge hose, install fill port cap.

**CAUTION**

Failure to fill the pump case with oil will damage the pump due to air becoming trapped inside.

SECTION 11 SPECIFICATIONS

11 Specifications

Following are the specifications for the Waterjet Pump. Included are the specifications for the equipment, torque, cutting water, cooling water, and the maximum quantity of orifices that can be supported.

11.1 Equipment Specifications

SL-IV Waterjet Pump Size	45 (60)	kW (hp)
Installation location	Indoors	
-Air borne dust/contaminants	Minimal	
Ambient temperature		
-Minimum storage	2(36)	°C(°F)
-Minimum operating	5(40)	°C(°F)
-Maximum operating	40(104)	°C(°F) (see note [1])
Maximum Relative Humidity		(see note [2])
-At Maximum Operating Temp.	95%	
Electrical		(see note [3])
-Motor type	TEFC	(see note [4])
Voltage / Service Amps	240/3/60	154
	480/3/60	77
		Volts/Phase/Hertz/Amps
Sound Level	77.16	dB(A)

(Note: Specifications listed below apply equally to 30 hp and 50 hp models)

Controls		
-Voltage	24	volts, DC
-Power Supply	10	amps, DC
-Safety shutdown switch settings		
High oil temperature	62 (144)	°C (°F)
Low oil level	80 (21)	1 (gal).
Booster pump overheat	53 (128)	°C (°F)
Hydraulic System		
-Oil tank capacity	170 (45)	1 (gal)
-Recommended oil type		
Regular applications		Mobil, DTE Heavy Medium, # 60016-3 (IR # 05022702)
Food applications		Conoco AA-20 (IR # 49835762)
-Hydraulic oil operation		
Minimum temperature	15(60)	°C(°F)
Maximum temperature	65(150)	°C(°F)

- Note** [1]: Based on motor nameplate data, oil temperature must be maintained within operating specifications.
 [2]: When relative humidity is above 50%, frequently check oil in tank for water content.
 [3]: Not all motor voltages are readily available, check with factory for availability.
 [4]: Totally enclosed fan cooled.

SL-IV Waterjet Pump Size	45 (60)	kW (hp)
Optimum temperature	46(115)	°C(°F)
Hot oil shutdown	62(144)	°C(°F)
Fluid Filtration Rating	Beta 10 >/= 100	Note [6]
Fluid Cleanliness Level	17/14	Note [7]
-Hydraulic Pump Type	Piston	
Displacement	Variable	
Pressure	Compensated	
Flow rate	65(17)	l/min(gpm)
-Hydraulic Hi-Lo Settings (factory)		
Lo pressure	bar (psi)	
Hi pressure	206 (3000)	bar (psi)
-Hydraulic oil cooling		
Total heat rejection	9.0 (12)	kW (hp)
Cooling fluid requirements at inlet fluid temperature	18 (65)	°C (°F)
Maximum cooling flow	11.3 (3.0)	l/min (gpm)
Maximum inlet pressure	6.9(100)	bar (psi)
Pressure drop	2 (30)	bar (psi)
Cutting Water "IN"		
-Minimum inlet pressure	2.4 (35)	bar (psi)
-Maximum inlet pressure	7 (100)	bar (psi)
-Maximum outlet pressure	8.3(120)	bar (psi)
-Maximum inlet temperature	29(85)	°C (°F)
-Optimum inlet temperature	18(65)	°C (°F)
-Factory Booster Pump Settings		
Inlet Pressure	4 (58)	bar (psi)
Outlet Pressure Set at	8.3(120)	bar (psi) (see Note [8])
Cutting Water Out		
-Maximum flow rate	4.4(1.17)	l/min(gpm)
-Maximum allowable pressure	4,100 (60,000)	bar (psi)
Compressed Air		
-Flow rate maximum	0.028 (1.0)	m ³ /min(cfm)
-Inlet pressure range	75-85 (5-6)	bar (psi)
Service Connections		
-Cutting water in	1/2" NPT	
-Cutting water out	9/16"	60,000 psi HP fitting
-Cooling water in	1/2" NPT	
-Cooling water out	1/2" NPT	
-Plant air in	1/4" NPT	
-Cutting water drain	1/2" NPT	
-Oil tank drain valve	1/2" NPT	
-Oil tank fill port	3/4" male JIC	

Note [6]: Beta filtration rating—There are 100 particles per ml larger than 10 microns upstream of the filter for each particle (per ml) greater than 10 microns downstream of the filter.

Note [7]: ISO-4406 fluid cleanliness ratings—17 ~ < 1,300 particles per ml > 25 microns // 14 ~ < 160 particles per ml > 15 microns.

Note [8]: Booster pump discharge pressure is dependent on inlet pressure.

11.2 Torque Specifications

Recommended Torque Values—Hydraulic Intensifier and HP Connections



Do not exceed torque values, excess torque can cause component damage or failure with potential hazards to equipment and personnel.

Item	Torque Nm (ft-Lb)	Wrench mm (inch)
Hydraulic Intensifier		
Hydraulic Cylinder		
End bell bolt	200(145)	M12 hex
Proximity switch	17(13)	M5 hex
Cylinder Flange Nut	27 (200)	1-7/16 hex
Seal Head		
Gland Nut	176(130)	30 (1-3/16) Crowfoot
HP Tubing Nut	67(50)	(13/16) Crowfoot
Pneumatic Valve		
3/8" Inlet	67(50)	(13/16) Crowfoot
1/4" Outlet	34(25)	(5/8) Crowfoot
H P Fitting Gland Nuts		
1/4" Nut	34(25)	(5/8) Crowfoot
3/8" Nut	67(50)	(13/16) Crowfoot
9/16" Nut	149(110)	(1-3/16) Crowfoot

NOTE

Measurements are made with lubricated components and a calibrated torque wrench. Inconsistencies in wrench settings, lubrication, and technique, may not produce a leak tight seal. If leakage persists, increase the torque until the components seal, do not exceed a value 15% greater than shown. If leakage persists there is a component problem. **EXCESSIVE TORQUE MAY DAMAGE OR REDUCE THE LIFE OF COMPONENTS.**

Use of an antiseize thread lubricant, like High Purity Goop (P/N 10084440) is highly recommended for tightening of stainless steel HP water fittings.

A torque wrench kit is available from KMT Waterjet. (P/N 49895436).

11.3 Cutting Water Specifications

The cutting water supply to the waterjet pump must meet the following specifications. High concentration of dissolved solids, especially calcium, silica, and chlorides, will affect high pressure component life. A water analysis will indicate the type of water treatment necessary.

Water Quality Parameters	Minimum Requirement	Better	Best
Alkalinity (mg/l)	50	25	10
Calcium (mg/l)	25	5	0.5
Carbon Dioxide (mg/l)	0	0	0
Chloride as Cl (mg/l)	15	1	0.1
Free Chlorine (mg/l)	0.05	0.05	0.05
Iron as Fe (mg/l)	0.2	0.1	0.01
Magnesium as Mg (mg/l)	0.5	0.1	0.1
Manganese as Mn (mg/l)	0.1	0.1	0.1
Nitrate (mg/l)	25	25	10
Oxygen (mg/l)	2	1	0.1
pH Value	6.5 - 8.5	6.5 - 8.5	6.5 - 8.5
Silica (mg/l)	15	10	1
Sodium (mg/l)	50	10	1
Sulfate (mg/l)	25	25	1
Total Dissolved Solids (mg/l)	200	100	5*
Total Hardness as CaCO ₃ (mg/l)	25	15	1
Turbidity (NTU)	5	5	1

* Do not reduce beyond this amount or the water will become too aggressive.

11.4 Cooling Water Specifications

Depending on the type of cooling system (closed recirculation, once through, etc.), the following common problems can be experienced:

Closed recirculation:

- Corrosion
- Fouling

Once through:

- Corrosion
- Fouling
- Scale
- Microbiological

Scale control is the most common problem, and is the result of insoluble matter deposited on the heat transfer surface. Calcium carbonate is the primary cause of scale when calcium bicarbonate breaks down. As the temperature of the water increases it becomes less able to hold carbonates in suspension.

To predict the tendency of scale formation, the Langelier's saturation index can be used as a guide.

Saturation Index = pH-pH_s where pH_s is calculated at saturation with calcium carbonate.

A positive index indicates a tendency to deposit calcium carbonate, the higher the positive value, the higher the scale formation. A zero index corresponds to water that is in equilibrium with respect to calcium carbonate.

11.5 Orifice Support Capacity

The SL-IV Waterjet Pump supplies high pressure (HP) water up to 4,100 bar (60,000 psi). The following table shows size, ratings, and maximum quantity of orifices that can be supported.

Rated power kW(hp)	Pressure Bar (Psi)	Flow lpm (gpm)	Qty	Orifice Diameter mm (inch)
45 (60)	4,100 (60,000)	3.87 (1.023)	1	0.36 (0.014)
			1	0.33 (0.013)
			2	0.28 (0.011)
			2	0.25 (0.010)
45 (60)	3,800 (55,000)	4.43 (1.17)	1	0.38 (0.015)
			1	0.36 (0.014)
			1	0.33 (0.013)
			1	0.30 (0.012)
			2	0.28 (0.011)
			2	0.25 (0.010)

PARTS LISTS

For:

**SL-IV PLUS
60HP**

High Pressure Waterjet Pump

To contact the KMT Waterjet Systems Spare Parts Department:

USA Parts Department
KMT Waterjet Systems
Production Equipment Group
635 West 12th Street / POB 231
Baxter Springs, KS 66713-0231
USA
Phone: (800) 826-9274
Fax: (620) 856-5050
E-mail: wj_service@kmtwaterjet.com

Europe: Spare Parts Manager
KMT Waterjet Systems GmbH
Wasserstrahl-Schneidetechnik
Auf der Laukert 11
D-61231 Bad Nauheim
Germany
Phone: 49-(0)6032-997-115
Fax: 49-(0)6032-997-271
E-mail: Spares.waterjet@kmtwaterjet.de

**SECTION 12 PARTS LISTS
480/3φ/60 – 50 hp SL-IV Single & Redundant**

12.1 General

This section contains parts lists for service procedures and part identification, along with electrical and plumbing schematics of the SL-IV 50 hp HP Waterjet Pump. The reader can use these parts lists to identify the part on a drawing, then find the part number and part description corresponding to the drawing balloon number. Replacement parts can be ordered with this part number information.

12.2 Part Nomenclature

The following abbreviations and numerical sizes are used for part descriptions in these parts lists:

Table 12-1 Part Description Abbreviations and Nominal Size Guide

Item	Description	Item	Description
Assy	Assembly	Mm sq.	Square millimeters
1/4, 9/16, 3/4	Nominal sizes in fractions of an inch, eg, 1/2 NPT ~ 0.50-inch national pipe thread, or 9/16 HP tube ~ 0.56-inch OD HP tubing or tube fitting	JIC	37-degree flared, threaded Hydraulic fitting, JIC standard, typically used on Hydraulic hose end connections.
Hydr	Hydraulic	Dia	Diameter
ID or OD	Inside diameter or outside diameter	Deg	Degree
psi or ksi	Pounds per square inch or thousands of pounds per square inch	-4,-8,-12	Hydraulic fitting nominal size, in 1/16 th's of an inch, eg, 1/2 OD tube ~ -8
HP and hp	HP: High Pressure, hp: horsepower	NO or NC	Normally open or normally closed
SAE O-ring	O-ring threaded port style, SAE standard		

Fig #	Figure Title	Part Number	Page #
12-1	Waterjet Pump	80072648	12-5
12-2	Intensifier Assembly	05144217	12-7
12-3	Seal Head Assembly	05144688	12-9
12-4	Hydraulic Piston	05132253	12-11
12-5	Hydraulic Cartridge	05130091	12-13
12-6	Hydraulic Plumbing Assembly	80073000	12-15
12-7	High Pressure Piping	80072655	12-17
12-8	Hydraulic Manifold Assembly	05071766	12-19
12-9	Bulkhead Piping	80073661	12-21
12-10	Low Pressure Filter Assembly	05149810	12-23
12-11	Hydraulic Power Unit	80072978	12-25
12-12	Motor/Pump Assembly	80072846	12-27
12-13	Reservoir Assembly	80074073	12-29
12-14	Electrical Assembly	80073083	12-31
12-15	Control Panel Configuration	80073117	12-33
12-16	Controls Subassembly	49836620	12-35
	Electrical Schematic	49836612	
	Hydraulic Schematic	49835622	

Figure 12-1. WATERJET PUMP 80072648

ITEM No.	QTY.	PART No.	DESCRIPTION
1	1	80072804	Frame Assembly
2	1	80072978	Hydraulic Power Package
3	1	80073083	Electrical Assembly
4	1	80073703	Decal Package
21	4	05059605	Spring
24	--	05022702	Hydraulic Fluid
25	1	05128087	Start-Up Tag
26	1	05135702	Test Report
27	1	80073000	Hydraulic Hose Connections
28	1	80074073	Reservoir Assembly
29	1	80073661	Bulkhead Pipe Assembly
31	1	80072655	HP Water Assembly

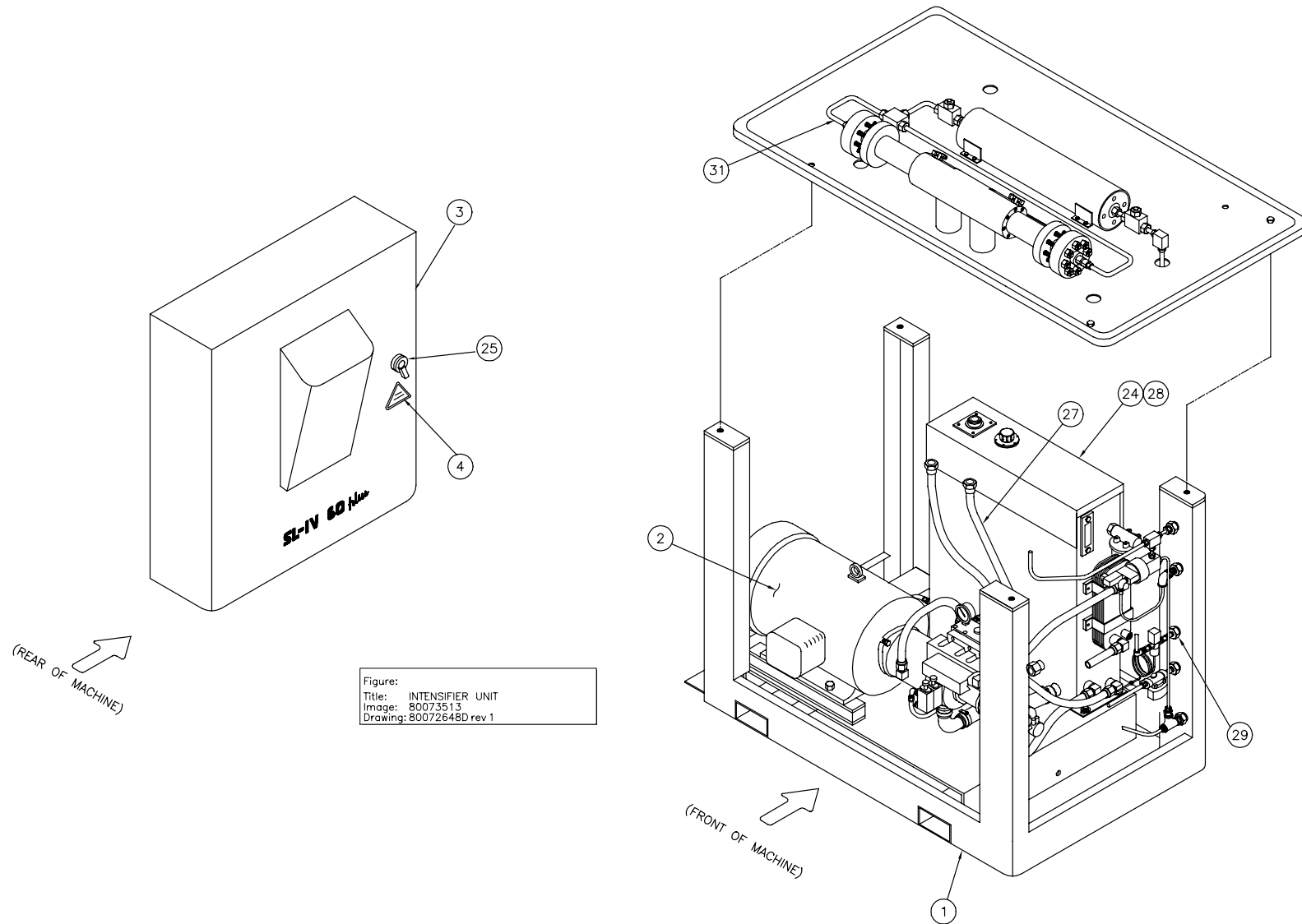

Figure 12-2. INTENSIFIER ASSEMBLY 05144217

ITEM No.	QTY.	PART No.	DESCRIPTION
1	2	05144647	Body, Cylinder, HP, 1.13-in. ID
2	2	05119151	Plunger, Ceramic
3	2	05144688	Head Assembly, Sealing
4	2	05147913	Head, Cylinder
5	2	05149703	HP Seal Assembly
6	2	05144696	Sealing Head Spacer
7	2	05144225	Flange Ring
8	2	05130091	Low Pressure Hydraulic Cartridge Seal Assembly
9	2	05007786	Bushing Retaining Flange
10	12	05144753	Stud, 7/8-9 x 6.00
11	2	05144712	Liner, HP Cylinder
12	4	10074904	O-ring
13	2	05144209	End Flange
14	2	05034798	Ring, Retaining
15	1	05034764	Cylinder, Hydraulic
16	2	10075000	O-ring
17	2	05034855	Ring, Backup
18	16	05141106	Cap Screw, Socket Head, M14x60
19	2	05127584	Switch, Proximity, 20-250 VAC/VDC
20	4	10183572	Cap Screw, Socket Head, M6x1x22mm, 316/304 Stainless
21	1	05132253	Piston Assembly, Hydraulic
22	12	10069904	Heavy Hex Nut, 7/8-9
23	2	05049812	Mounting Stem
25	8	05079652	Cap Screw, Socket head, M10 x 1.5 x 85mm, Grade 12.6
26	8	05061486	Washer, Lock, High Collar, M10, Stainless
27	2	10074409	O-ring
28	2	05144183	Spacer, Proximity Switch
29	2	05081872	Gasket, Drip Pan, Upper
30	*	10148674	Special Tool, HP Seal Removal (Not Shown)
31	*	05066139	Special Tool, Wrench, HP Cylinder (Not Shown)
32	*	05004924	Special Tool, Plunger Removal

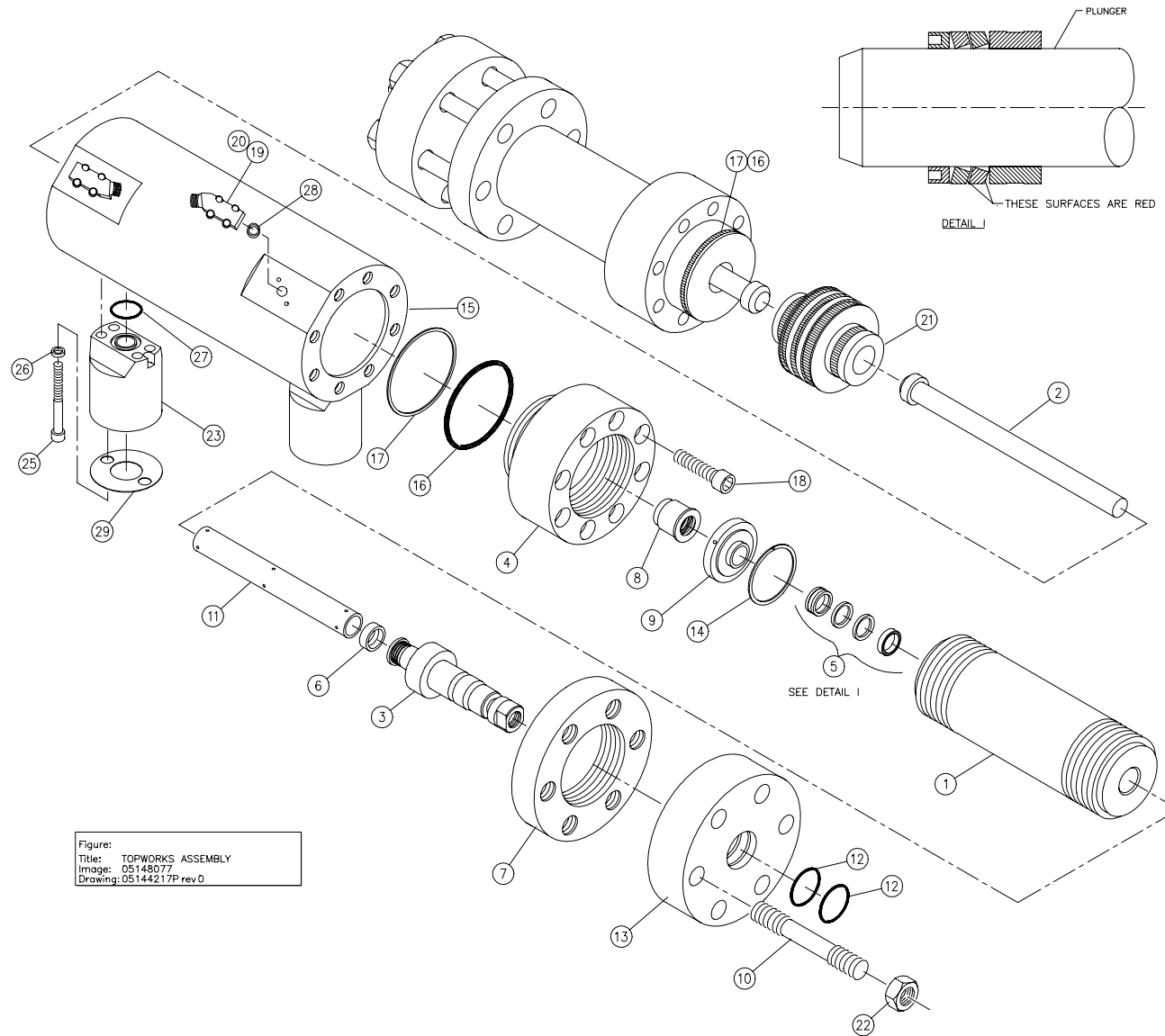

Figure:
Title: TOPWORKS ASSEMBLY
Image: 05148077
Drawing: 05144217P rev 0

Figure 12-3. SEALING HEAD ASSEMBLY 05144688

ITEM No.	QTY	PART No.	DESCRIPTION
1	1	05144357	Body, Sealing Head
2	1	05144662	Poppet, Inlet, Cutting Water
3	1	05116777	Gland, HP, Sealing Head
4	1	05112768	Seat, HP, Sealing Head
5	1	05116561	Poppet, Valve, HP Check
6	1	05144670	Retainer, Poppet
7	1	05147863	Spring, Compression
8	1	49884562	Spring, Compression
9	1	05116751	Pin, Guide

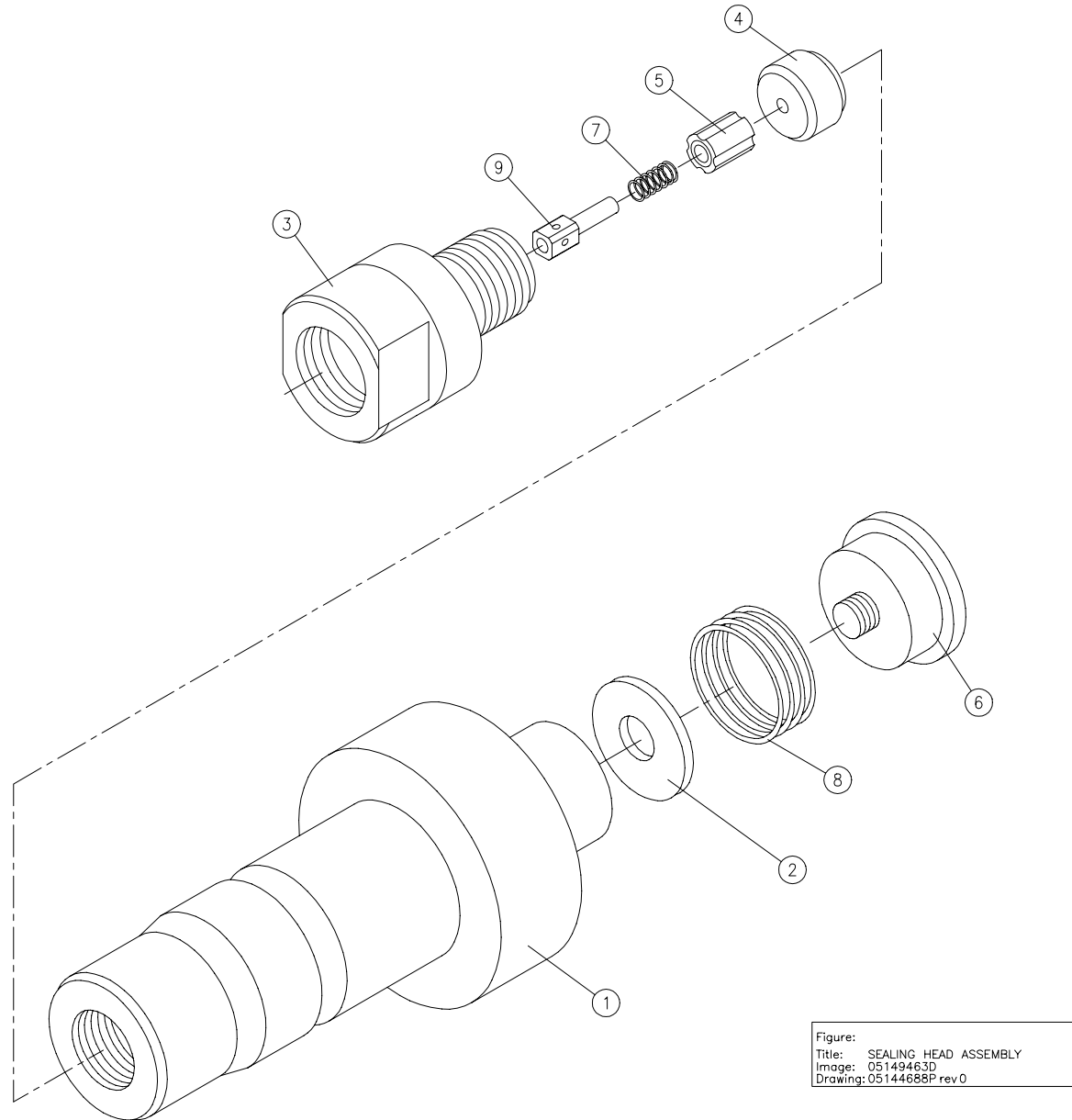

Figure:
Title: SEALING HEAD ASSEMBLY
Image: 05149463D
Drawing: 05144688P rev 0

Figure 12-4 HYDRAULIC PISTON ASSEMBLY 05132253

ITEM No.	QTY	PART No.	DESCRIPTION
1	1	05132261	Body, Hydraulic Piston
2	12	05074380	Pin, Clevis
3	2	05049887	Screw, Set, Socket, with Through Hole
4	2	10148757	Valve, Check, Cartridge, with O-ring
5	--	49877509	Adhesive, Thread Locker
6	2	05088364	Ring, Snap, Flat Wire
7	2	05049994	Ring, Backup
8	2	05087713	O-ring
9	1	05117965	Seal Assembly, Hydraulic Piston
10	2	05117940	Bearing, Hydraulic Piston

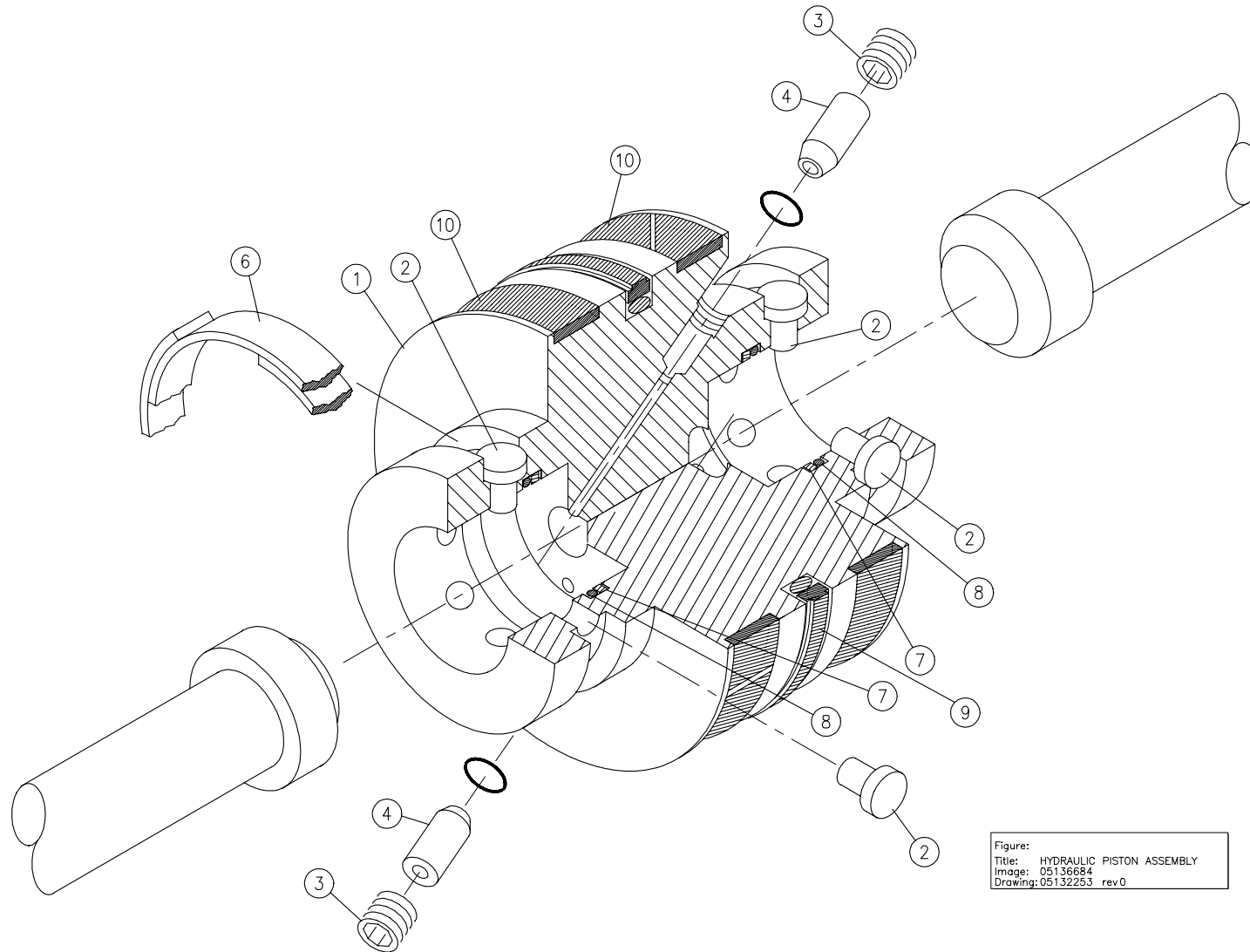

Figure 12-5 HYDRAULIC CARTRIDGE SEAL ASSEMBLY 05130091

ITEM No.	QTY	PART No.	DESCRIPTION
1	1	05130109	Body, Seal, Cartridge
2	2	05015060	Seal, U-Cup, with O-ring
3	1	10193522	O-ring
4	1	05050760	Ring, Backup
5	1	05129481	O-ring
6	1	05013024	O-ring
7	1	05129515	Back-up Ring
8	1	05027255	Seal, U-Cup
Ref 1	0	05015136	Tool, Seal Smoothing
Ref 2	0	05009048	Tool, Seal Installation

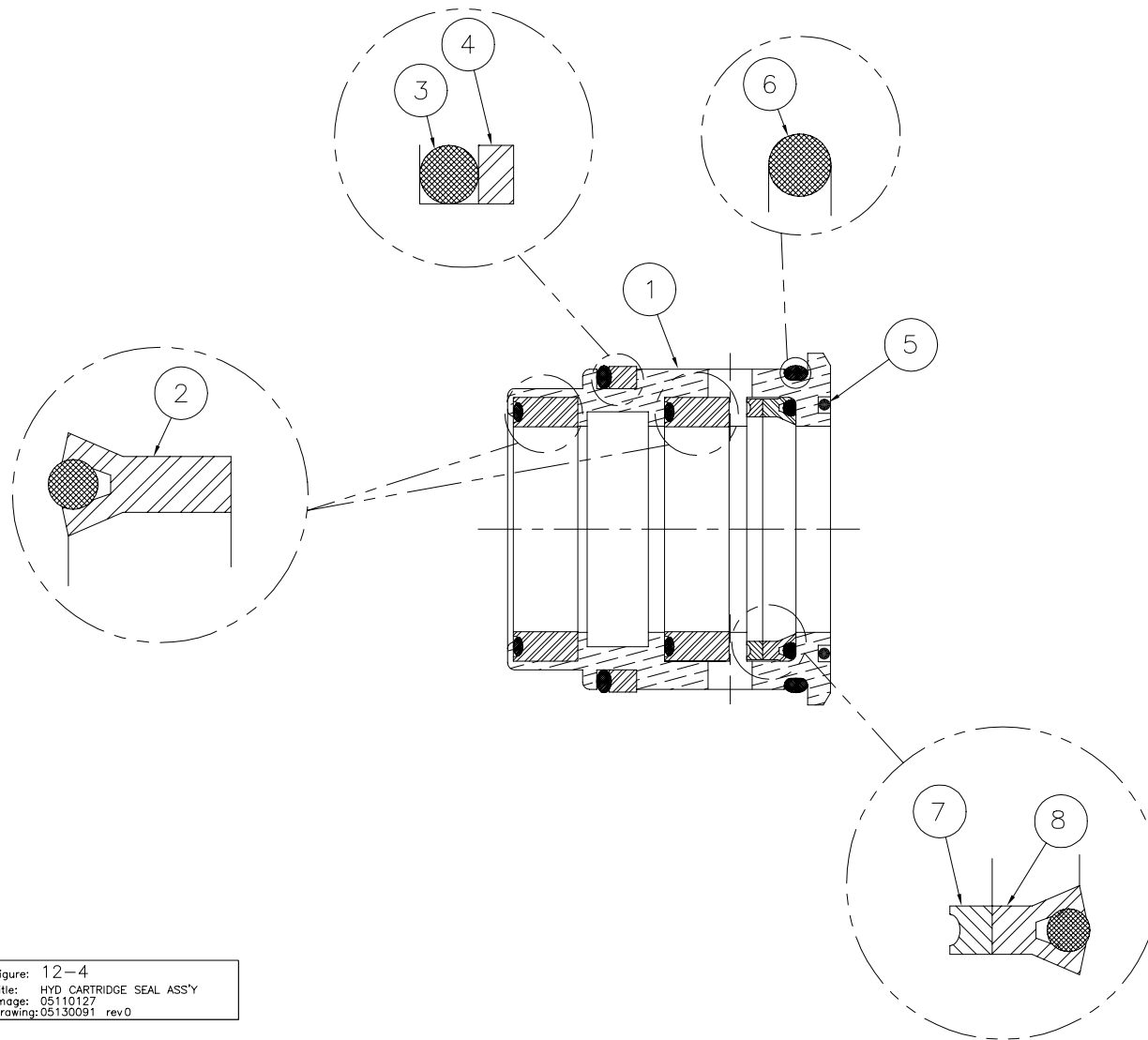

Figure: 12-4
Title: HYD CARTRIDGE SEAL ASS'Y
Image: 05110127
Drawing: 05130091 rev.0

FIGURE 12-6 HYDRAULIC PLUMBING 80073000

ITEM No	QTY	PART No.	DESCRIPTION
1	1	05106950	Hose Assembly, Hydraulic, .75" ID, -12 JIC Swivel, Both Ends, 19"
2	1	05106968	Hose Assembly, Hydraulic, 1.00" ID, 1.25 JIC Swivel, Both Ends
3	1	80074099	Hose Assembly, Hydraulic, 1.00" ID, -16 JIC Swivel, Both Ends
4	2	10083517	Hose Clamp
5	6.3"	10179018	Radiator Hose, 2.00"
6	1	05048780	Split Flange Kit, 2.00"
7	1	05048806	Split Flange Elbow,
8	11	05112750	Hose Assembly, Hydraulic, .25" ID, -4 JIC Swivel, Both Ends, 26.25"
9	1	05051214	Hose Assembly, Hydraulic, .25" ID, -4 JIC Swivel, Both Ends, 39"
10	2	05049713	Hose Assembly, Hydraulic, .75" ID, -12 JIC Swivel, Both Ends, 27"
11	2	05071105	Hose Assembly, Hydraulic, .75-in. ID, -12 JIC 90-deg x -12 JIC Swivel
12	1	05071121	Hose Assembly, Hydraulic, .25" ID, -4 JIC Swivel, Both Ends, 18"
13	2	05052493	Elbow, 45 Degree, -12 JIC x -10 SAE O-ring, Steel
14	2	95702619	Adapter, Straight, -12 JIC x -12 SAE O-ring, Steel
15	3	10142644	Adapter, 90-deg, -4 JIC x -4 SAE O-ring, Steel
16	1	10144749	Adapter, 45-deg, -4 JIC x -4 SAE O-ring, Steel
17	1	05071113	Adapter, Straight, -12 JIC x -12 SAE O-ring, Long, Steel
18	1	05050331	Elbow, 90 Degree, -12 JIC x -10 SAE O-ring, Steel
19	1	10153831	Adapter, Straight, -16 JIC x -16 SAE O-ring, Steel
20	1	49876089	Adapter, 45-deg, M/F, -4 JIC x -4 SAE O-ring, Steel

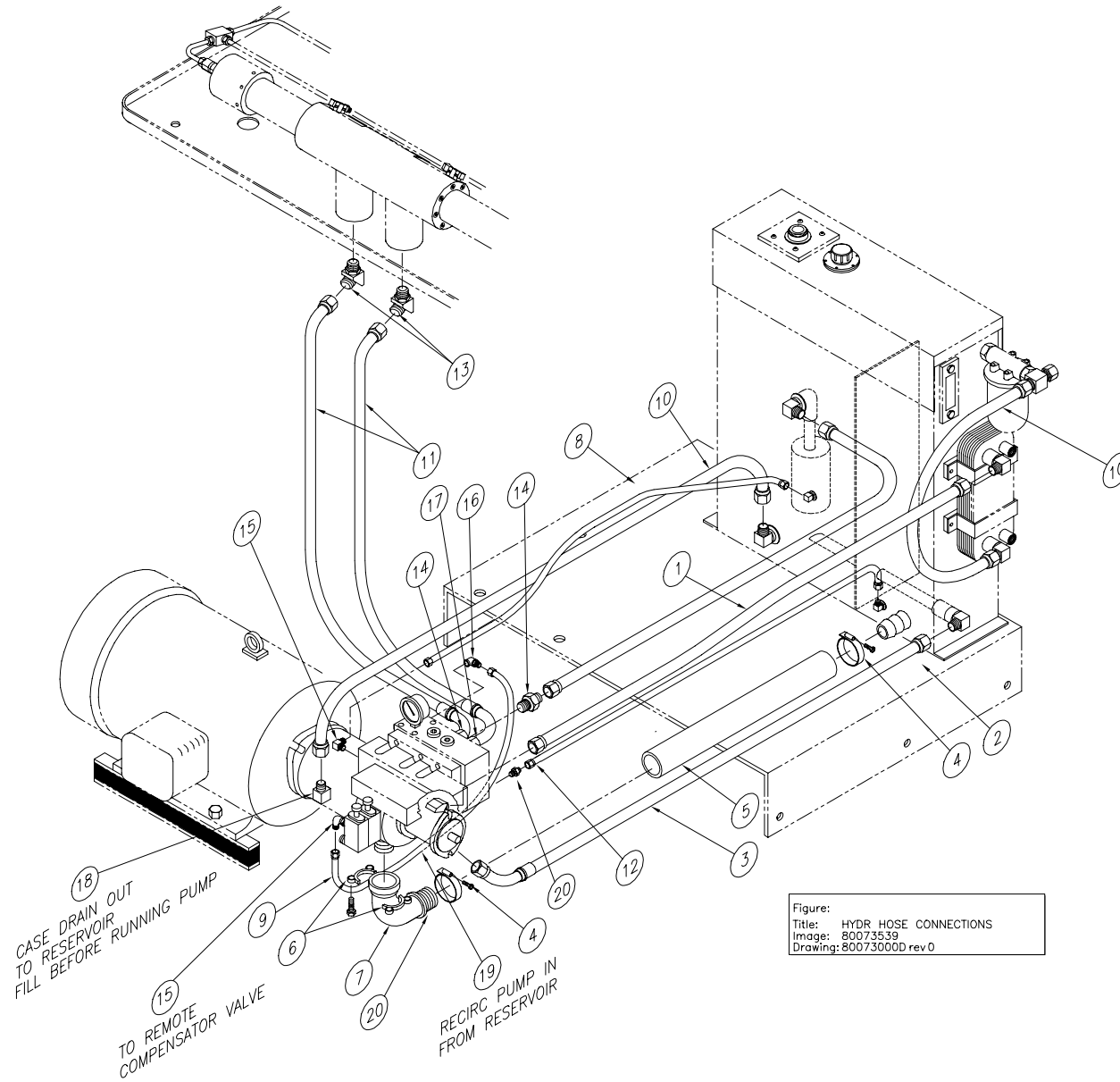

Figure:
Title: HYDR HOSE CONNECTIONS
Image: 80073539
Drawing: 80073000D rev 0

FIGURE 12-7. HIGH PRESSURE PIPING 80072655

ITEM No	QTY	PART No.	DESCRIPTION
1	2	49830599	Tee, .38-in. HP Tube, 60 ksi, Stainless
2	1	05148846	Tube, Bent, .38-in. HP, 60 ksi, Stainless
3	1	10078590	Tee, .38-in. HP Tube, 60 ksi, Stainless
4	1	05148853	Tube, Bent, .38-in. HP, 60 ksi, Stainless
5	1	05148861	Tube, Bent, .38-in. HP, 60 ksi, Stainless
6	2	10078772	Plug-HP, .56
8	1	05144217	Intensifier Assembly, SL-IVK
9	1	05040696	Accumulator, HP, .96 liter (56 cu. in.), 4,200 bar, TUV
10	1	10184760	Pneumatic Valve Assembly
11	1	10079580	Adapter, HP, 9-4, M/F
12	2	10078913	Gland, .38-in. HP Tube, 60 ksi, Stainless
13	2	10078715	Collar, .38-in. HP Tube, 60 ksi, Stainless
14	2	10079465	Tee, HP, .56, 60ksi, Stainless
15	1	05106794	Tube, .56-in. HP, x 9.81 Lg.
16	1	10079705	Bulkhead Coupling, .56
17	3	10078525	Elbow, HP, .56, 60ksi, Stainless
18	1	05109939	Tube, .56-in. HP, x 10.69 Lg.
19	20"	05086905	Conduit, Extra Flexible, .63-in. ID
20	6	05131347	Ferrule, .50
21	1	05112552	Tube, .25-in. HP, x 34.00 Lg.
22	2	10069326	Tube, .56-in. HP, x 4.00 Lg.
23	1	10094704	Tube, .38-in. HP, x 3.00 Lg.
24	12	10083897	Ferrule, .25
25	80"	10186153	Conduit, Extra Flexible, .38-in. ID
26	4	05144837	Spacer-Accumulator
27	8	95383790	Cap Screw, Socket Head, ½ - 13 x 1-in., Stainless
28	8	95413696	Washer, Lock, ½-ID
29	2	05090717	Nut, Retaining, HP Accumulator
30	1	10077030	Elbow, Poly, 90 degree, .25
31	1	05145297	Tube, .56-in. HP, x 4.18 Lg.
32	2	10078129	Gland, .38-in. HP Tube, 60 ksi, Stainless

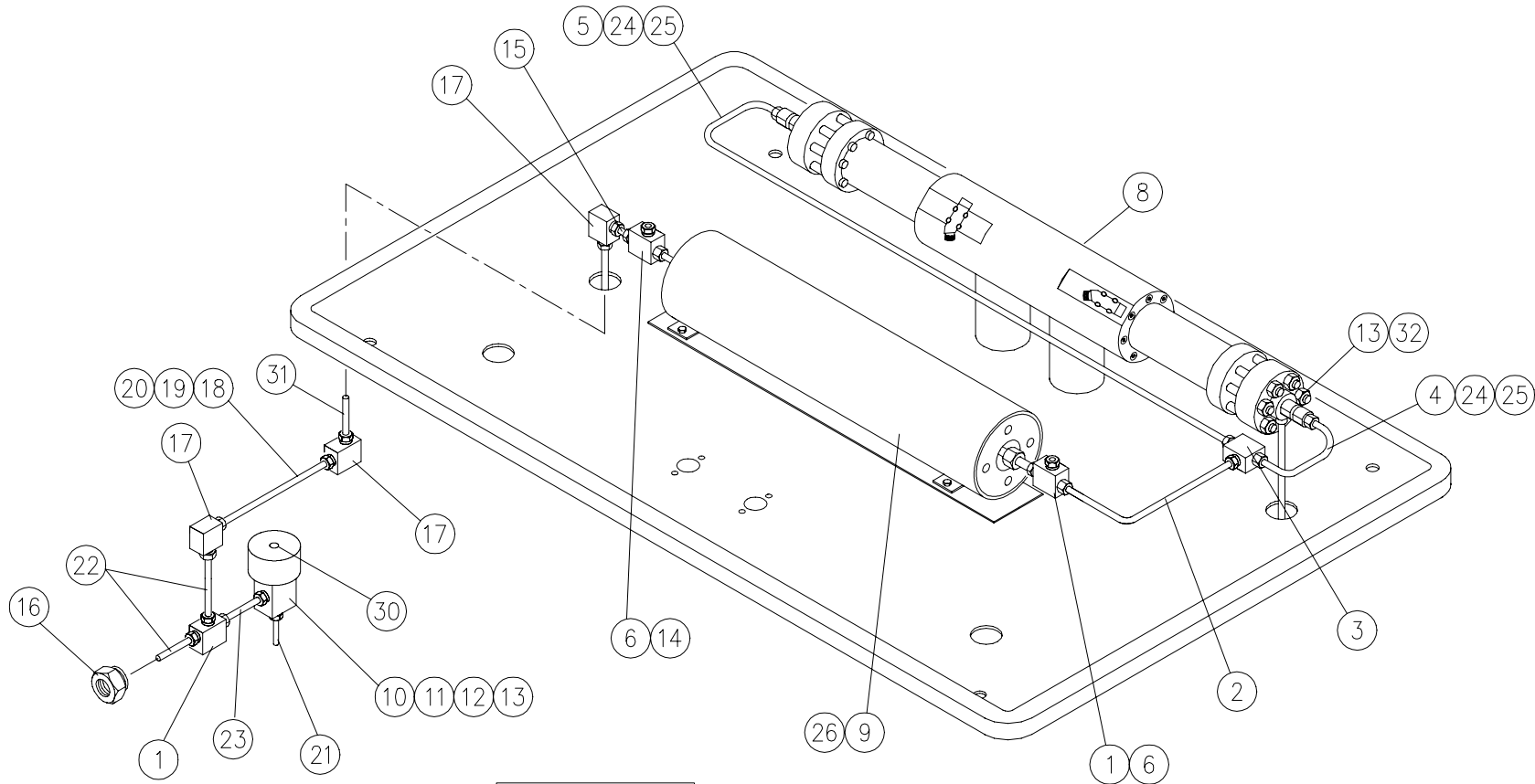

Figure:
Title: HP WATER ASSEMBLY
Image: 80073547
Drawing: 80072655D rev 0

Figure 12-8. HYDRAULIC MANIFOLD ASSEMBLY 05071766

ITEM No.	QTY.	PART No.	DESCRIPTION
1	1	05044144	Block, Manifold, Hydraulic
2	3	05071055	Plug, -12 SAE O-ring, Hex Socket, Steel
3	1	05071717	Valve, Relief, Hydraulic, 234 bar (3,400 psi), Non-adjustable, TUV
4	2	05055017	Plug, -2 SAE O-ring, Hex Socket, Steel
5	1	10185585	Valve, Solenoid, Hydraulic, 24 – VDC, Normally – Closed, 2-Way/2-Position
6	1	05045497	Gage, Pressure, Hydraulic, 0 – 5,000 psig, -4 SAE O-ring, Bottom-Mount
7	1	10187052	Valve, Relief, Hydraulic, 100 – 3,000 psi Range, Knob-Adjustable
8	1	10187060	Valve, Relief, Hydraulic, 25 – 800 psi Range, Adjustable
9	1	10074953	O-ring
10	1	49889744	Retainer, Valve, Cartridge, 1-in.
11	1	49889736	Valve, Check, Hydraulic, Cartridge
12	1	49889769	Plug, -.25 SAE O-ring, Hex Socket, Steel
13	1	10189595	Kit, O-ring, 4-way Valve (6 each O-ring)

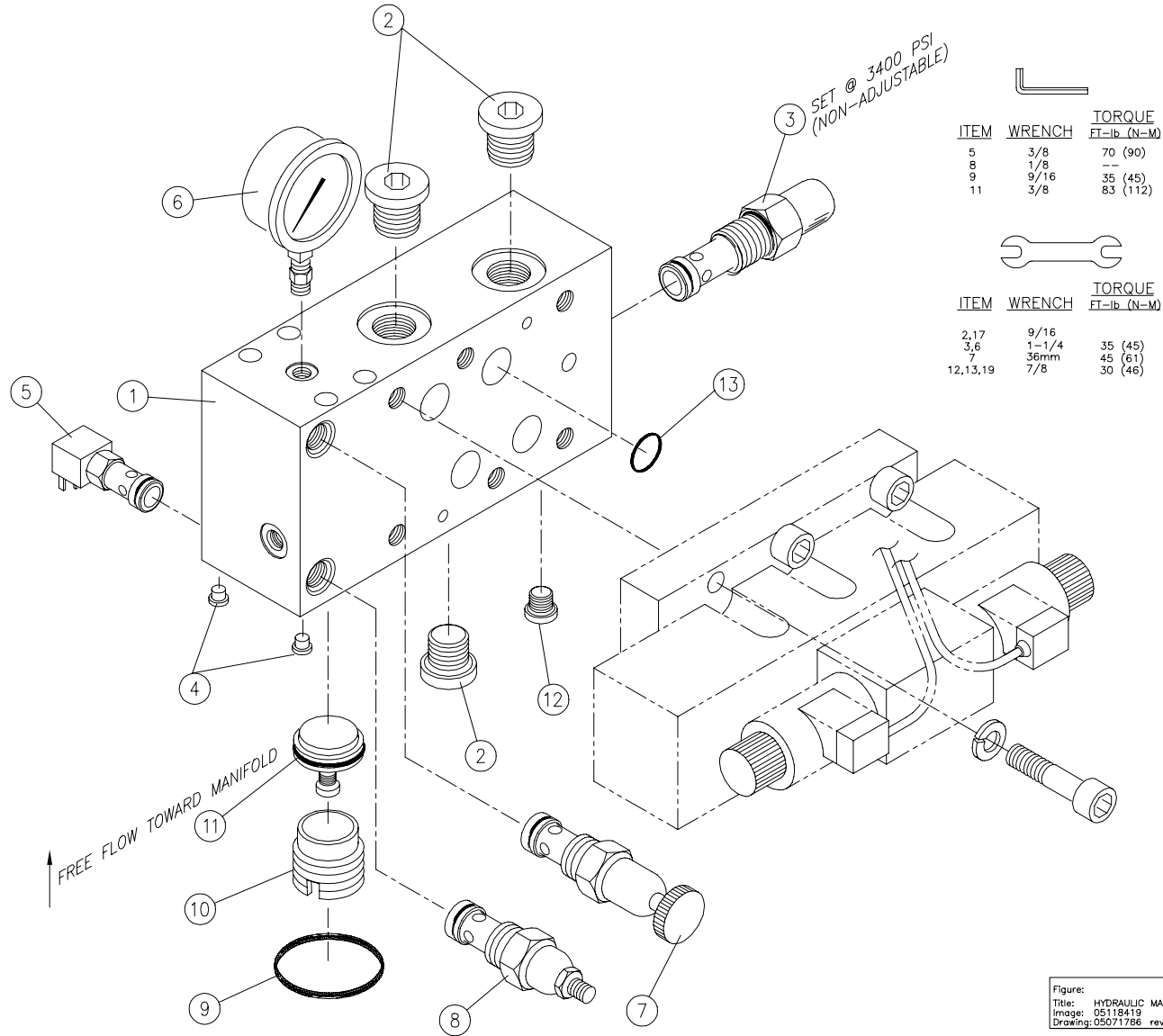

Figure:
Title: HYDRAULIC MANIFOLD ASS'Y
Images: 05118413
Drawing: 05071786 rev 9

Figure 12-9. BULKHEAD PIPING ASSEMBLY 80073661

ITEM No	QTY	PART No.	DESCRIPTION
1	2	10147460	Elbow, 90 Deg, ½ - NPT x -8
2	1	10091866	Water Modulating Valve
3	1	05060207	Nipple, ½ - NPT x 5-in
4	1	10192425	Barb Insert, .50
5	1	49890239	Solenoid Vlv, 24-VDC , .50 NPT
6	4	49886922	Adapter, Bulkhead, ½ - NPT
7	-	10127348	Hose, Push-On, .50-in. ID
8	1	49888035	Solenoid Vlv, 24-VDC , .13 NPT
9	4	10070092	Nut, Jam, Hex, 1 -14 UNC
10	1	10073823	Tee, Male Run, ½-NPT
11	2	05061643	Cap Plug, 1.50
12	1	05149810	Filter Assembly, LP
13	1	49834328	Adapter, .25 OD Tube x ½-NPT,
14	2	05061312	Seal, Hole, 2.20-in. Conduit
15	1	10078335	Reducing Nipple, .25 x .125
16	1	10077055	Adapter, Bulkhead, 4-15, Brass
17	1	10078095	Coupling, Poly, .25
			22 1 49830581 Bulkhead Coupling, .38 x .56
			24 5 10189025 Adapter-Hose/JIC, -8 x -8
			25 2 05111398 Quad Stem
			26 4 49832959 Screw-Hex Head, 5/8-11 x 1.75
			27 4 49833072 Lock Washer, .63
			29 1 10084523 Nipple, ½-in. NPT x4-in.,
			30 24" 10079903 Tube, Polyethylene, .25-in.
			32 1 49834310 Adapter-Tube/Pipe,.50
			33 1 49834302 Adapter-Tube/Pipe,.50, Stub
			34 2 05111380 Quad Body
			36 2 05111406 Adapter-Straight, .25 NPT x -8
			37 2 49886989 Adapter-Pipe/JIC, Str, -6 x-8
			38 2 10079713 Barb, .50 ID Hose x ½-NPT,
			39 3 10173805 Barb, .50 ID Hose x -8 JIC Swvl
			40 4 05113964 Grommet
			42 2 10173805 Barb, .50 ID Hose x -8 JIIC
			43 1 95157418 Adapter-Pipe/JIC, 8

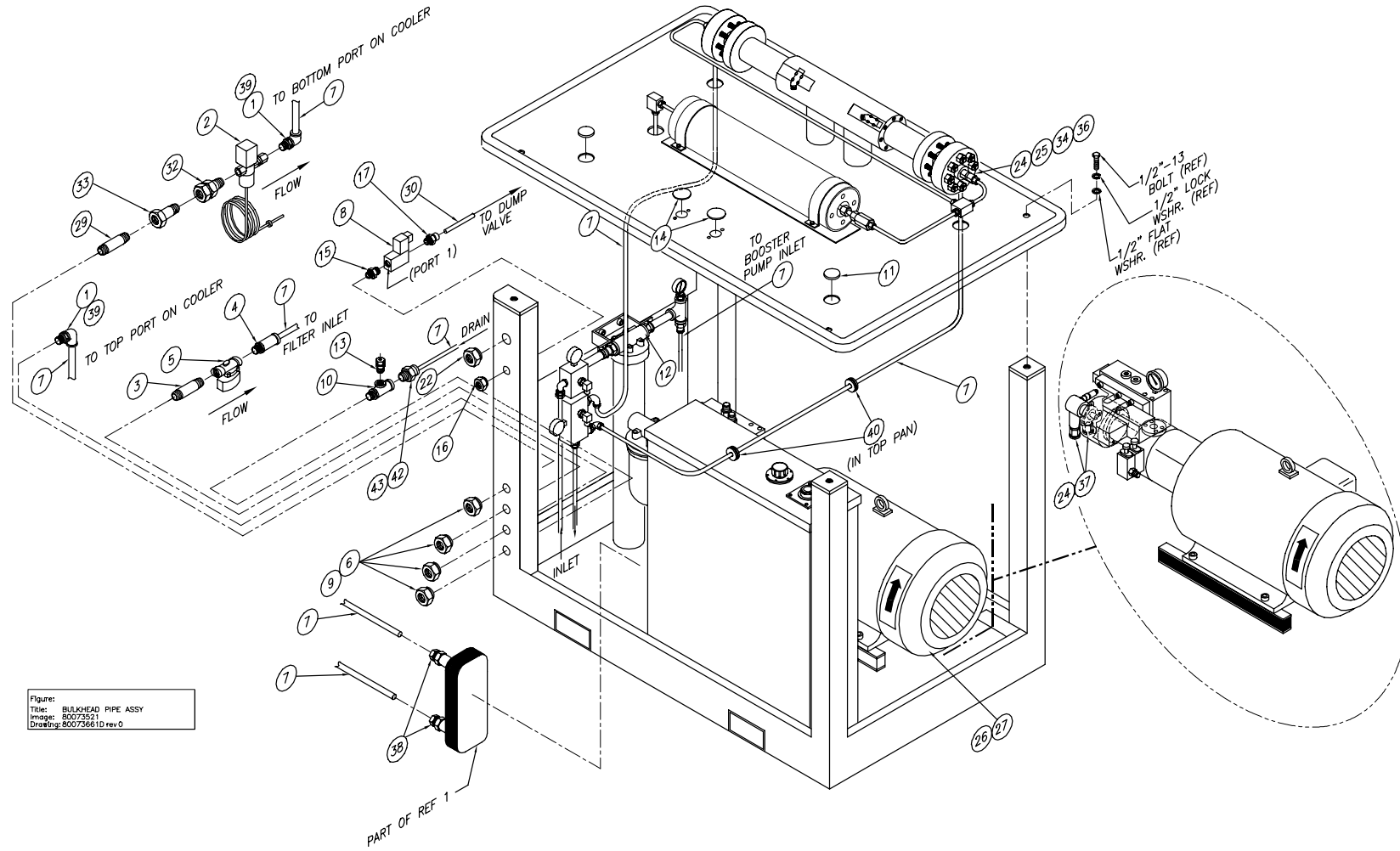

Figure:
Title: BULKHEAD PIPE ASSY
Image: 80073521
Drawing: 80073561 D rev 0

Figure 12-10 LOW PRESSURE WATER FILTER ASSEMBLY 05149810

ITEM No.	QTY.	PART No.	DESCRIPTION
1	1	05044052	Gage, Pressure, 0-200 psig, ¼ NPT, Stainless, Bottom-Mount
2	3	10100428	Adapter, Bushing, ½ x ¼ NPT, Stainless
3	1	05070982	Valve, Relief, 50 - 150 psi, ½ NPT
4	2	05074067	Nipple, ½ NPT x 3-in., Stainless
5	2	10078111	Adapter, Bushing, ¾ x ½ - NPT, Stainless
6	1	49836729	Low Pressure Manifold
7	2	05135629	Low Pressure Manifold
8	2	05135660	Elbow, JIC/O-ring, 90 Degree, -8 x 2
9	2	05135645	Adapter-Pipe/Hose Barb, -8NPT x -8 Hose
10	1	05038690	Body, Filter, Water, ¾ - NPT
11	3	05135652	Check Valve
12	4	10192425	Barb Insert
13	2	05105440	Gage, 0 - 100 psig, Dual Scale, ¼ - NPT, 2.5-in. Diameter
14	2	10106722	Element, Filter, LP Water, Polypropylene, 10 Micron
15	1	10189025	Adapter-Hose/JIC, .50 x .50
16	2	10114023	U-Bolt, ¼ - 20, Stainless
17	1	10113983	Tee, ½ - NPT, Stainless
18	1	05140751	Pressure Switch
19	1	95416335	Nut, Hex, ¼ - 20
20	1	95838314	Washer, Lock, .25
21	1	95391322	Washer, Flat, .25
22	1	05142062	Pressure Switch
23	1	49868813	Temperature Sensor

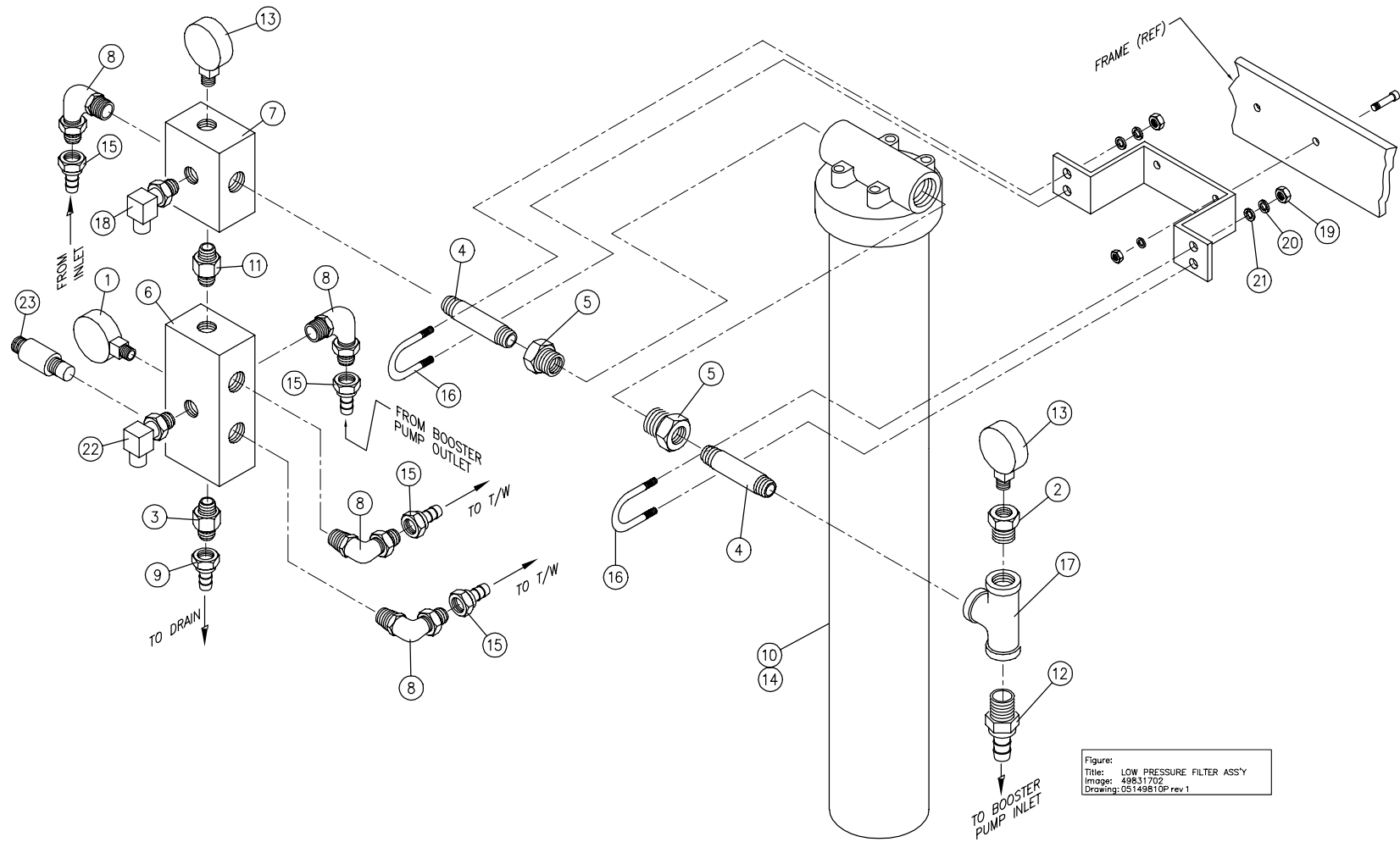

Figure:
Title: LOW PRESSURE FILTER ASS'Y
Image: 49831702
Drawing: 05149810P rev 1

Figure 12-11. HYDRAULIC POWER UNIT 80072978

ITEM No	QTY	PART No.	DESCRIPTION
1	1	80072846	Motor/Pump Assembly
2	1	05049168	Water Pump Adapter
3	3	95572897	Hex Head Screw, 1/4-20 x 5/8
4	3	95838314	Lock Washer, 1/4
5	1	49887094	Vane Water Pump
6	4	05123591	Stud, .63
7	4	80073190	Spacer Block
8	4	49884216	Heavy Hex Nut, 5/8-11
9	4	95416350	Hex Head Screw, 3/8-16 x 1-1/4
10	4	95688719	Lock Washer, .63
11	4	10117372	Washer, .38
12	1	10092302	Shaft Coupling
13	2	10116952	Cap Plug
14	2	95750394	Lock Washer, 3/8
15	2	95416319	Hex Head Screw, 3/8-16 x 1
16	1	10091510	Decal
17	4	95013744	Socket Head Screw, 5/8-11 x 3
18	1	05092523	Directional Control Valve
19	6	95055026	Socket Head Screw, 1/2-13 x 1 3/4
20	6	95688750	High Collar Lock Washer, 1/2
21	2	10069714	Washer, 3/8
22	2	80073190	Spacer Block

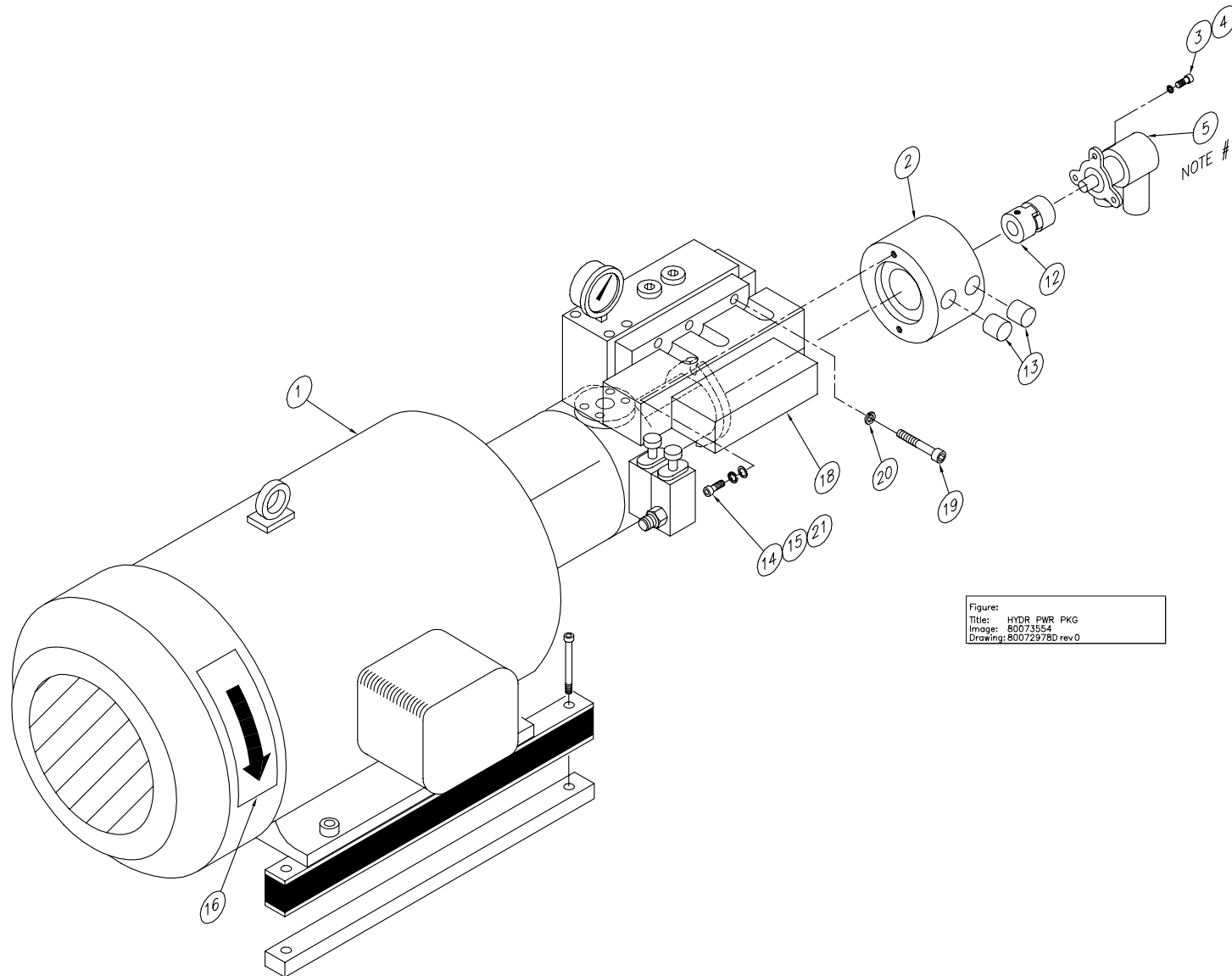

Figure 12-12. MOTOR/PUMP ASSEMBLY 80072846

ITEM No.	QTY	PART No.	DESCRIPTION
1	1	80072820	Shaft Coupling
2	1	80072838	Shaft Coupling
3	2	80072937	Vibration Isolation, Motor Base
4	1	05045513	Motor, Electric, 60hp
5	1	80072937	Flexible Coupling Insert
6	1	80072853	Flange-Motor/Pump
7	1	05045505	Piston Pump, Axial, Variable-Displacement, Pressure-Compensated, 71 cc/rev
8	2	05037593	Socket Head Screw, M10 x 1.50 x 25mm
9	2	10069714	Flat Washer, 3/8
10	1	05071766	Manifold Assembly
11	1	05047451	Adapter, JIC/O-ring, 90 Degrees, 12-12
12	1	05045364	Gear Pump, Double Shaft
16	4	05091756	Socket Head Screw, 7/16 - 14 x 6
17	4	05050356	High Collar Lock Washer, .44
18	1	10074953	O-ring
20	12	05089792	Flat Washer, 7/16
21	4	95876975	Hex Head Screw, 5/8-11 x 2
22	4	95688719	Lock Washer, .63

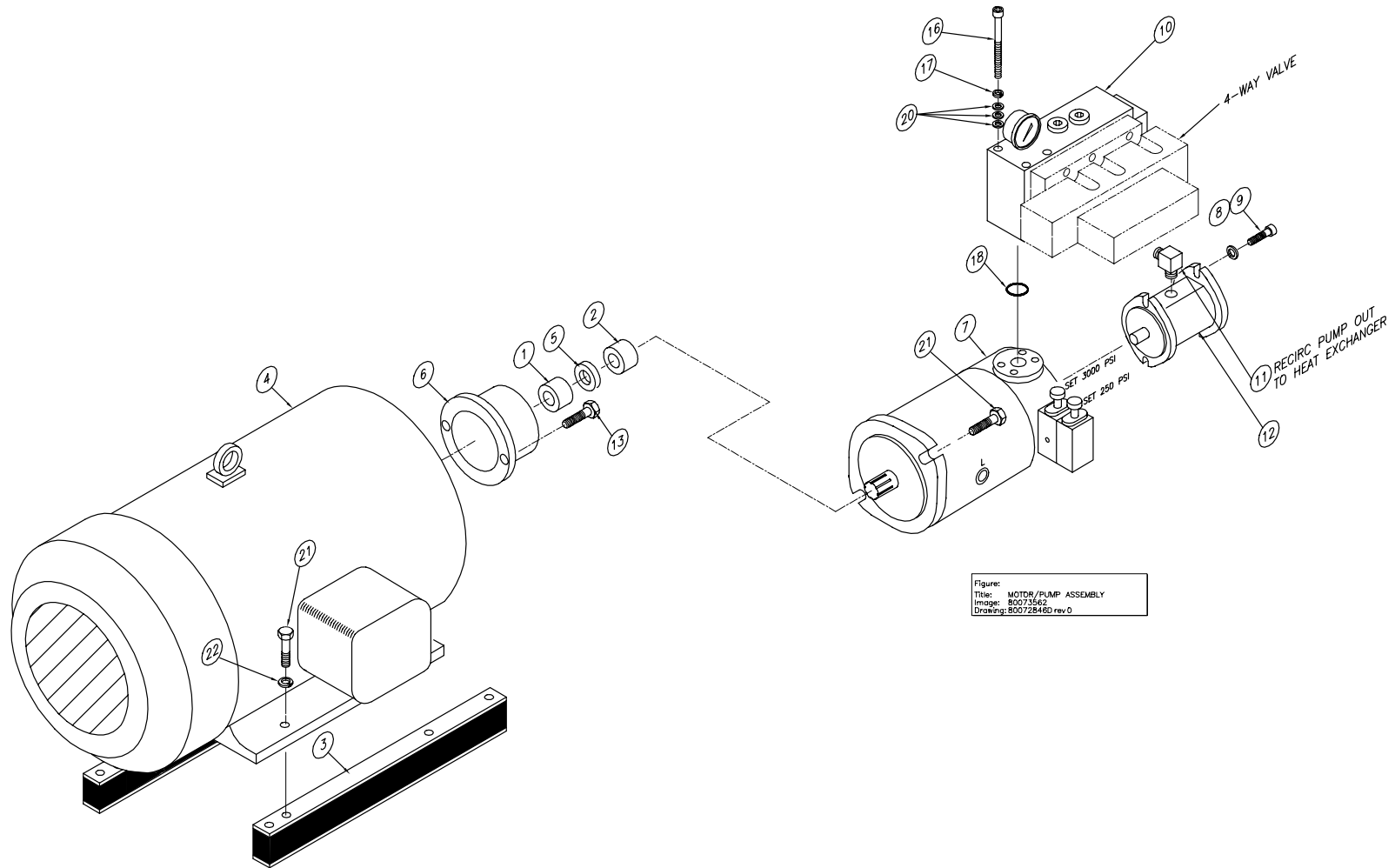

Figure 12-13 RESERVOIR ASSEMBLY 80074073

ITEM No.	QTY	PART No.	DESCRIPTION
1	1	80074040	Weldment, Reservoir
2	1	05104179	Gasket, Cover, Reservoir
3	1	05050026	Switch, Temperature / Level, Hyd, Cartridge- Type, 149 deg F
4	1	05092739	Breather, Air
5	1	10168862	Gage, Dual Scale, Level/Temperature, Oil
6	1	05103809	Housing, Filter, Hyd Oil, w/Gage
7	1	05104187	Element, Filter, Hyd Oil, Spin-on
8	1	05049655	Adapter, 90-Deg, 1" NPTx-12 JIC,
9	1	05069976	Cap, 3/4 NPT Hex, Steel
10	1	05071063	Tee, Male Branch, O-ring/JIC,-12,
11	1	05049713	Hose Assy, Hydraulic
12	1	05145941	Heat Exchanger
13	1	05060777	Adapter-JIC, 45 Degrees, M/F 12-12
14	1	95830766	Lock Washer, .31
15	1	10091858	Bulb Well, .75
16	2	95829248	Hex Head Screw, 5/16-18 x 1.00
17	1	05104195	Bushing-Straight Thread, 1.0 SAE M x .75 SAE F O-Ring Boss
18	1	05104203	Elbow-90 Deg, 1.25 Male NPT x 1.25 Male JIC
19	1	05079967	Gasket, Sensor, Hyd Oil, 0.06"
20	1	10170645	Adapter, Pipe/O-ring, Straight, 12-16
21	1	05079371	Adapter, Straight Swivel, -12 JIC x -12 BSPP
22	1	05006291	Diffuser, Return Line, Hyd Oil
23	2	10099901	Elbow, 90-Deg, 1/4 NPT x -4 JIC,
24	1	10080901	Valve, Shutoff, Manual, 1/2 NPT,
25	2	10091163	Adapter-JIC, 90 Degrees, 12-12
26	1	95033619	Plug, .50
27	2	05145966	Heat Exchanger Bracket

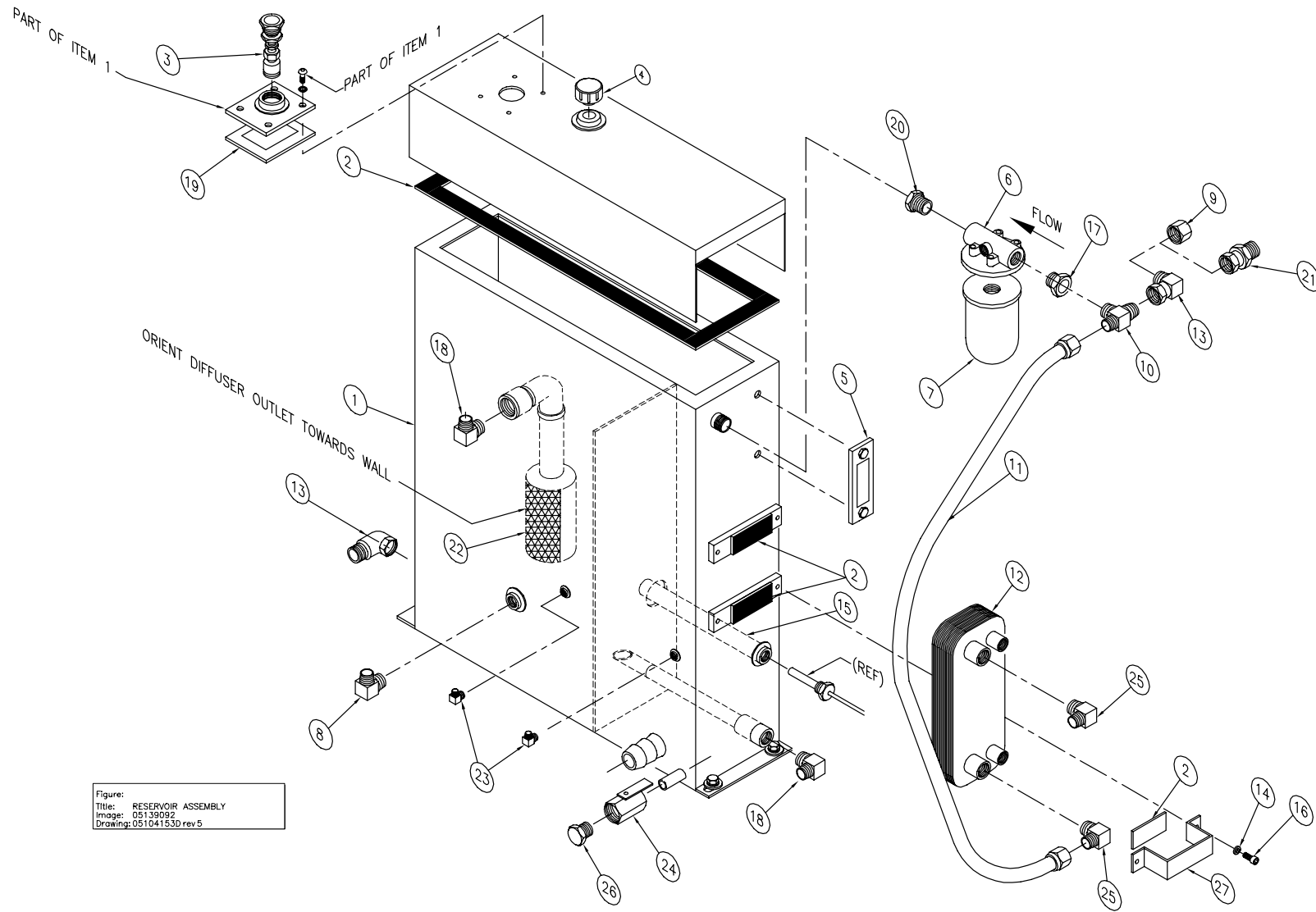

Figure:
Title: RESERVOIR ASSEMBLY
Image: 05139092
Drawing: 05104153D rev 5

Figure 12-14 ELECTRICAL ASSEMBLY 49831498

ITEM No.	QTY	PART No.	DESCRIPTION
1	1	05148531	Harness, Cable, Sensor/Solenoid
2	1	10080661	Flexible Conduit Connector
3	3	80073059	Terminal Ring
4	18"	10086700	Flexible Conduit
5	1	10115830	Flexible Conduit Connector
6	1	05081377	Conduit Bushing
7	12	10159143	#8 Terminal Ring
8	4	10069763	Washer, .50
9	124"	10180768	#00 Wire, Black
10	24"	05075692	Vinyl Tape
11	6	95423653	Socket Head Screw, 1/4-20 x 1/2
12	6	95416335	Hex Nut, 1/4-20
13	6	95686721	Socket Head Screw, 1/4-20 x 1-3/4
15	4	95423695	Hex Nut, 1/2-13
16	1	10174357	#6 Terminal Ring
18	4	95716890	Lock Washer, 1/2
19	5	10125912	Cable Tie
20	1	05148523	Electrical Panel Configuration
21	2	10085405	Gasket Assembly

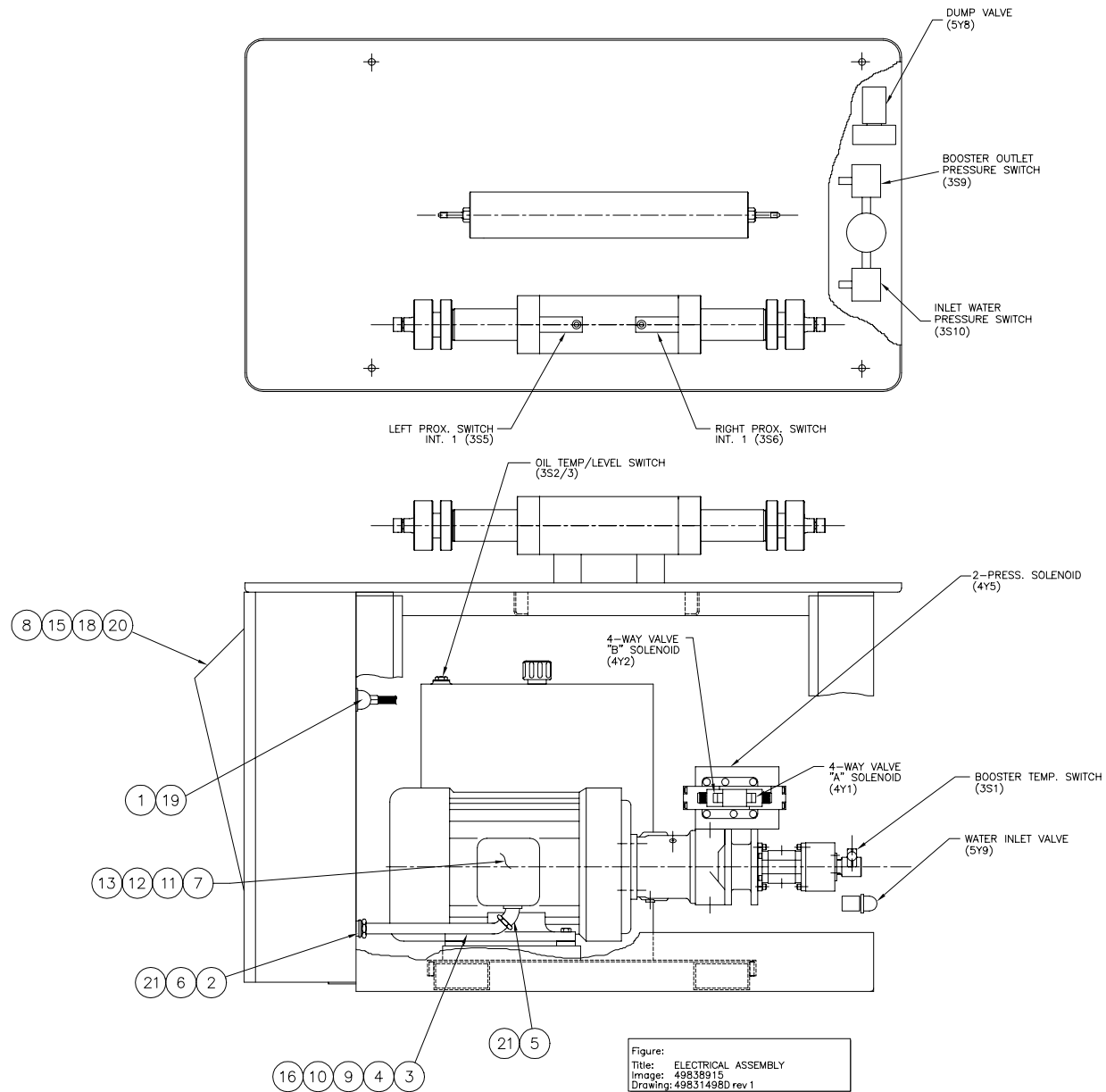
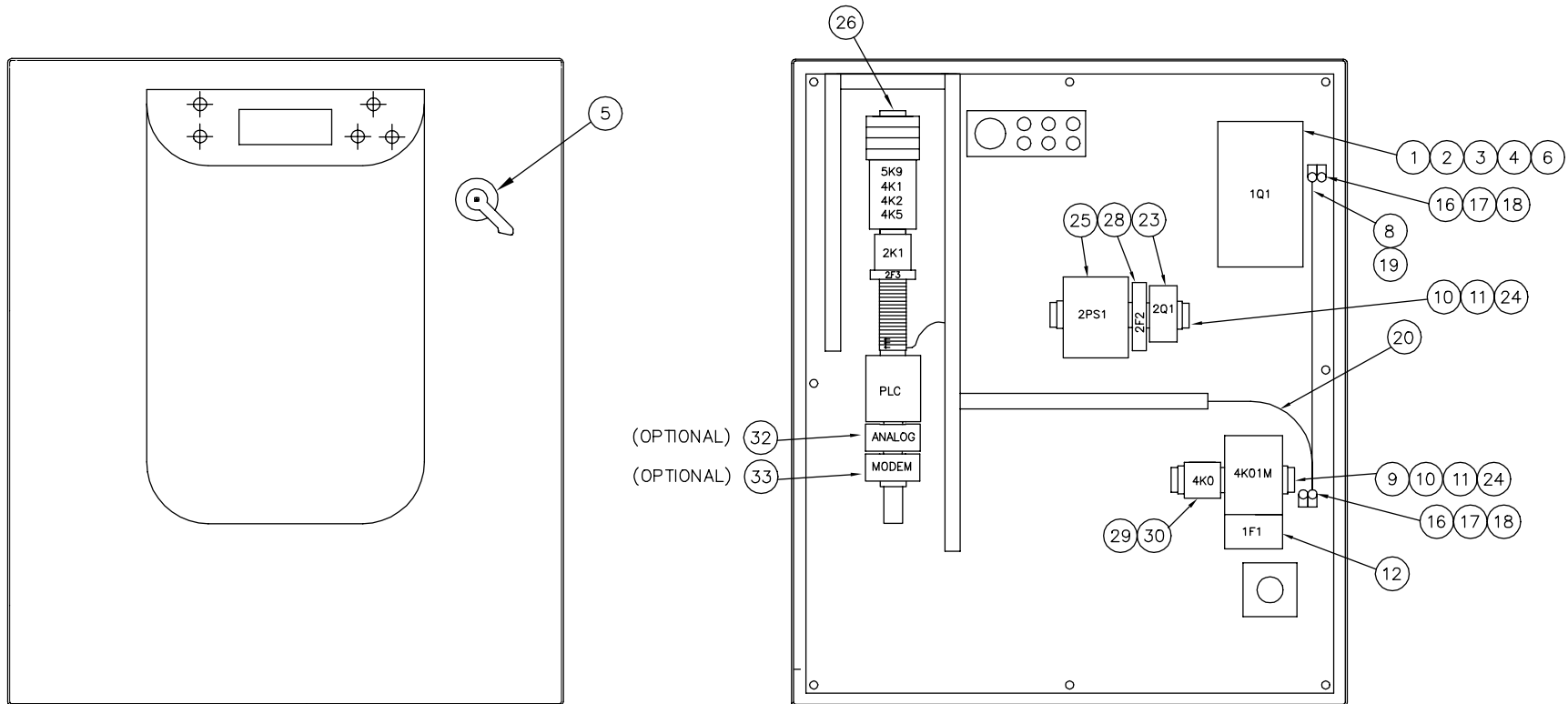

Figure 12-15 CONTROL PANEL CONFIGURATION 80073117

ITEM No.	QTY	PART No.	DESCRIPTION
1	1	05075635	Circuit Breaker, 200A
2	4	05081955	Screw, Socket Head, #8-32 x 2
3	1	05137963	Rotary Drive Mechanism
4	1	05075650	Extension, Shaft, Circuit Breaker
5	1	05075643	Handle, Open, Circuit Breaker
6	2	05106406	Terminal Cover
7	54"	10180768	#00 Wire, Black
8	8	05149778	Crimp Connector
9	1	05145537	Contactor, Non-Reversing, 185A
10	12	10157667	Screw, #10-32 x 3/4
11	15"	10103034	Din Rail
12	1	80073067	Relay Overload
13	8	10185395	Crimp Connector
14	48"	10176410	#16 Wire, Blue
15	48"	10170165	#16 Wire, Green/Yellow
16	2	95830766	Lock Washer, .31
17	2	05095609	Ground Lug
18	2	95423620	Screw-Hex Head, 5/16-18 x 3/4
19	24"	05106398	#3 Wire, Green/Yellow
20	42"	10170157	#10 Wire, Green/Yellow
21	90"	05019898	#14 Wire, Green/Yellow
22	12	05019617	Crimp Connectors
23	1	05140686	Circuit Breaker
24	3	05032362	End Anchor
25	1	05140876	Power Supply
26	1	49836620	Controls Subassembly
29	1	10098226	Relay Tube
30	1	10098242	Socket Screw Terminal Tube Base
31	60"	10181550	#16 Wire, Red
30	3	80073059	Terminal Ring



ENCLOSURE SHOWN IN THIS VIEW WITHOUT DOOR.

Figure:
Title: CTRL_PNL_CONFIG
Image: 49839020
Drawing: 80070667D rev 0

Figure 12-16 CONTROLS SUBASSEMBLY 49836620

ITEM No	QTY	PART No.	DESCRIPTION				
				32	1.2	05021944	Wiring Duct
1	--	10176410	#16 Wire, Blue	33	28	10170132	Rivet
2	--	10170165	#16 Wire, Green/Yellow	34	6	49874191	Hole Seal
3	3	05032420	Terminal Block	35	--	05140926	#16 Wire, Orange
4	--	10103034	Din Rail	36	--	10185395	Crimp Connector
5	12	10157667	Screw, #8-32 x 1/2	37	4	10069888	Lock Washer, #6
6	1	49839335	Circuit Breaker, 6a	38	1	05140082	Electrical Enclosure
7	1	49833403	Push/Pull Switch, ES	39	1	05140967	Gasket Connector
8	2	05140652	Contacto Block	40	--	10170157	#10 Wire, Green/Yellow
9	1	05049473	Legend Plate	41	3	10094712	Ring Terminal
10	20	05032438	Terminal Block	42	4	95416335	Hex Nut, 1/4-20
11	4	05032362	End Anchor	43	1	49833387	Pilot Light
12	1	05032370	End Barrier	44	1	05140975	Cap Connector
13	1	05032388	Jumper	45	--	10102242	Spiral Wrap
14	--	05112818	Marker	48	4	10069797	Washer, #6
15	--	05032412	Marker	49	1	05144316	Base Controller
16	1	10186104	Tube Base Relay	50	4	10070951	Screw, #6-32 x 3/4
17	1	10196012	Relay Base	51	1	05140157	Panelview Display
18	1	49833395	Push Button Switch	52	1	05115134	End Barrier
19	1	49833486	Contacto Block	53	1	49833411	Selector Switch
21	1	49833379	Pilot Light-Green	54	1	05114889	Legend Plate
22	14	05113634	Terminal Block	55	1	05117601	End Barrier
23	1.5	05112826	Terminal Block	56	1	10174431	Receptacle Connector
24	1	49830268	Cable Channel	57	37	10174712	Socket Contact
26	1	05049432	Legend Plate Holder	58	4	10069946	Hex Nut, #6
28	1	05140504	Sub-plate	59	1	05115704	Terminal Block
29	1	10156859	I/O Rack	60	1	05144308	I/O Rack
30	4	10146363	Single Point Module	61	1	49874233	Hole Seal
31	2	10157659	Lock Washer, .25				



REV. NO. 49835622D			
REVISIONS			
NO.	DESCRIPTION	DATE	APPROVED
1	REVISED PER JDS	5/13/03	
2	REVISED LP WATER CIRCUIT REF FOR REV02572	7/27/04	JDS
		7/27/04	JDS

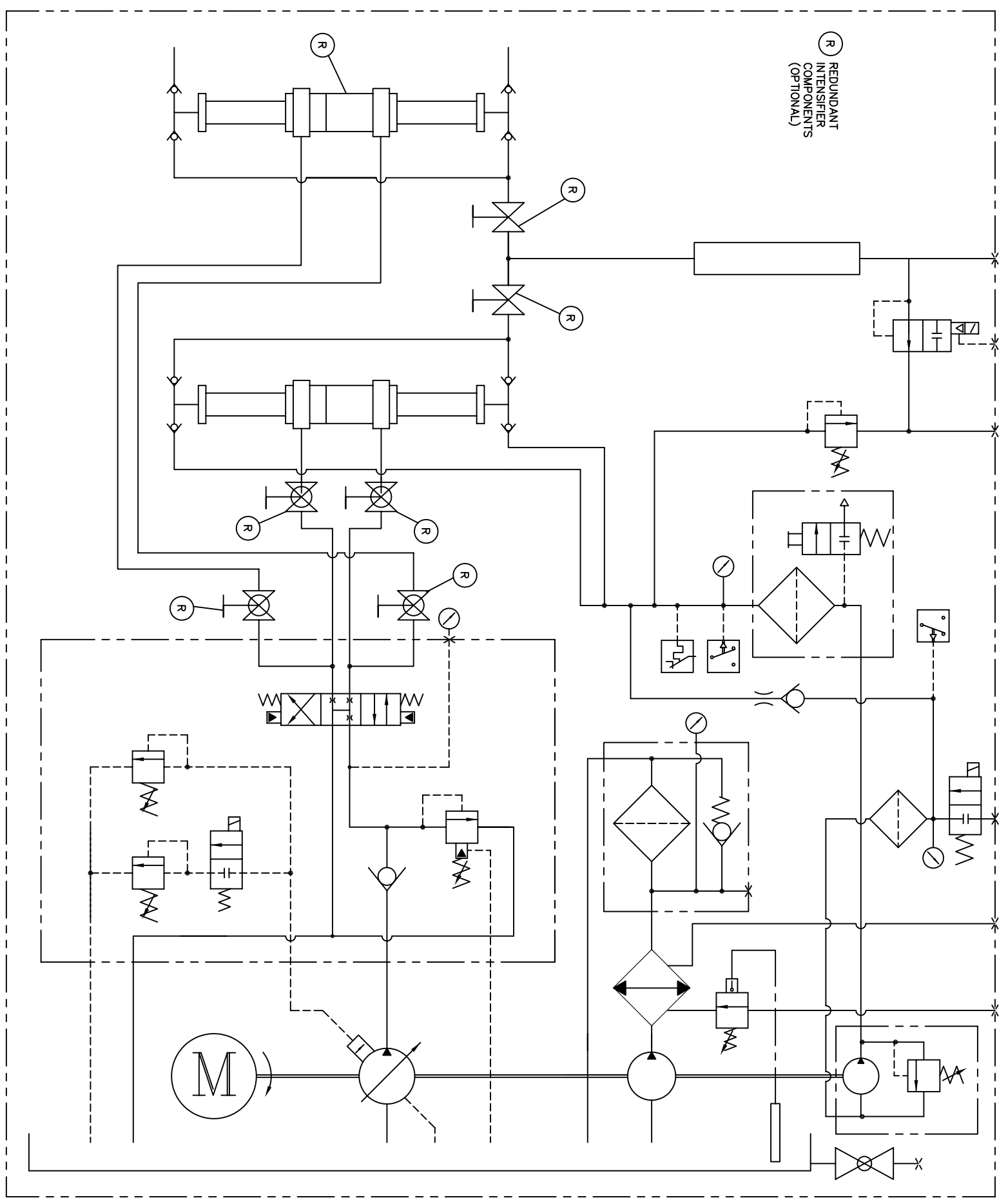

Copyright © 2003 KMT Waterjet Systems All Rights Reserved		PROPRIETARY NOTICE		STANDARD TOLERANCES UNLESS OTHERWISE NOTED: ALL DIMENSIONS ON COMMON CENTERLINE CONFORM TO 005 BREAK SHARP EDGES AND CORNERS .015 SURFACE FINISH 6.3 STANDARD TOLERANCES: X.XX = ±.003 X.XXX = ±.015 X.XXX = ±.005 ANGLE = ±2°		GD&T TO ASME Y14.5M 1994		REF. DIM. 05075510		TITLE KMT Waterjet Systems SCHEMATIC-SYSTEM SLV/SLV REDUNDANT	
WARNING ! The export or reexport of this drawing or a product produced by using the information contained herein is prohibited by the U.S. Export Administration regulations and other applicable governmental restrictions or regulations.		This document contains confidential and trade secret information and its release to the receiver in confidence. The receiver by receipt hereof agrees that, except as authorized in writing, it shall not disclose the confidential or trade secret information therein; (2) not copy the confidential or trade secret information therein; and (3) not disclose the confidential or trade secret information therein to others without the written consent of the sender. Upon demand return the document, all copies thereof, and all material copied therefrom.		ALL DIMENSIONS IN INCHES (mm)		HEAT TREAT		DESIGNED BY DATE B. Rumble 5/12/03		DRAWN BY DATE H. Shields 5/12/03	
NEXT ASSEMBLY				HARDNESS				ENR. APPROVAL & DATE		SCALE: THIRD ANGLE PROJECTION	
										TITEL BLOCK REVISION: 1 SHEET 1 OF 1	

1 2 3 4 5 6 7 8 9

REV. NO.		80070642D	3	2
NO.	DESCRIPTION	REVISIONS	DATE	APPROVED

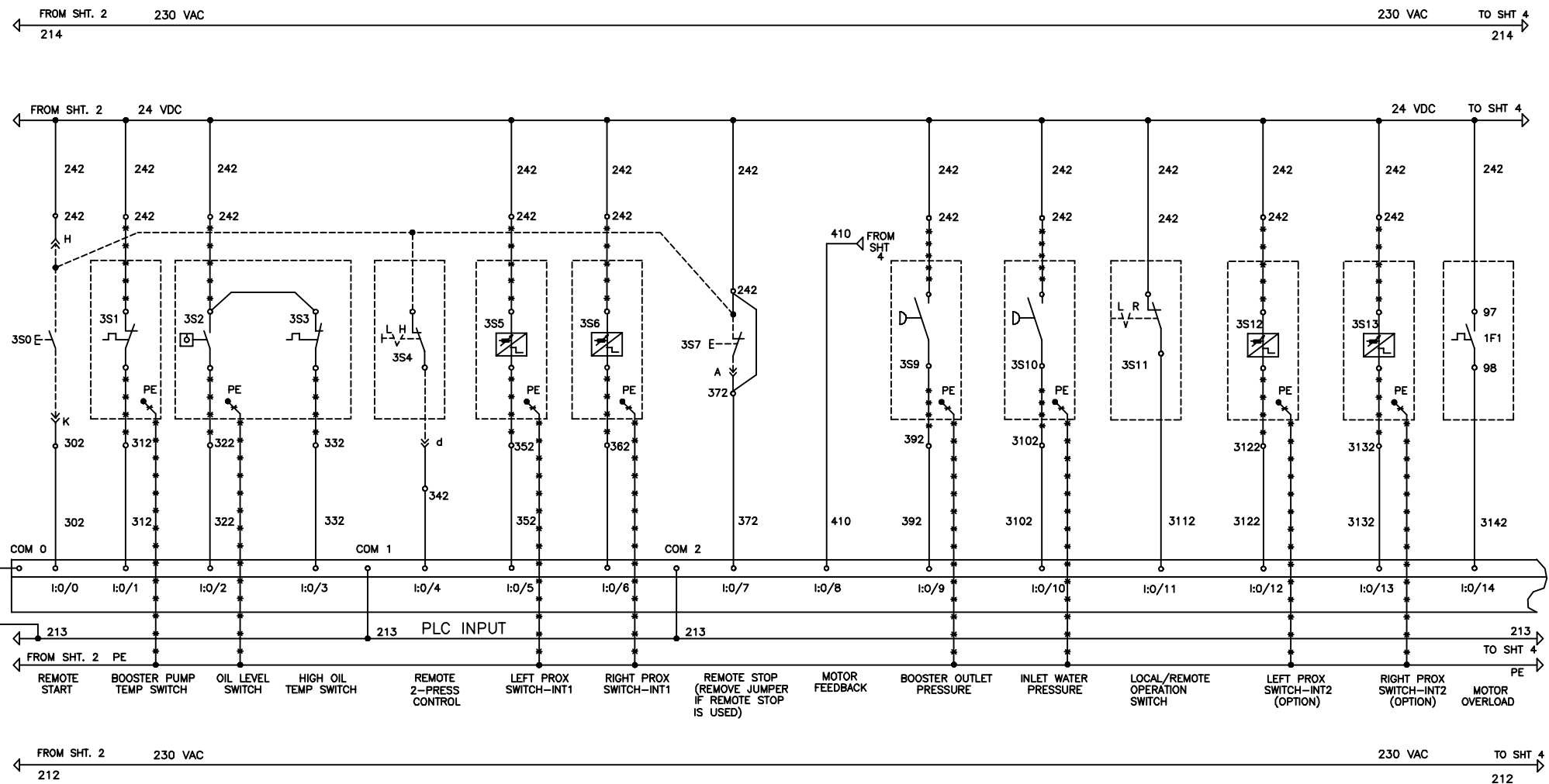

----- WIRING BY CUSTOMER IN ACCORDANCE WITH LOCAL REGULATIONS
 ----* WIRING BY I-R EXTERNAL TO PANEL
 ALL AC CONTROL VOLTAGE WIRES MUST BE RED IN COLOR

Copyright © 2001 Ingersoll-Rand Company All Rights Reserved WARNING 1 The export or re-export of this drawing or a product produced by this drawing is subject to U.S. Export Administration regulations and other applicable governmental restrictions or regulations.	PROPRIETARY NOTICE This document contains confidential and trade secret information, is the property of Ingersoll-Rand Co., and is given to the recipient in confidence. The recipient by receipt and retention of this document accepts the document in confidence and agrees that, unless authorized in writing by Ingersoll-Rand Co., it will (1) not use the document or any copy thereof or the contents of the trade secret information therein, (2) not copy the document or its contents to other personnel, (3) not disseminate or otherwise reveal to retain the document, or (4) upon completion of the document, or upon demand, or at any other time, return the document, all copies thereof, and all materials copied therefrom.	STANDARD TOLERANCES UNLESS OTHERWISE NOTED: ALL DIMENSIONS ON COMMON COORDINATING CONVAL TO 2008 SURFACE FINISH - √ STANDARD DIMENSIONS: FXX = 2.043 JXX = 2.015 KXX = 2.000 MXX = .52	GD&T TO ASME Y14.5M 1994 ALL DIMENSIONS IN INCHES (mm) SURF. FIN. - DIM. BY 8 DIT W.C.L. 9/11/01 CHECKED BY 8 DIT G.N. 9/11/01 DRK APPROVE'S DATE G.P.N. 9/11/01	REF. NO. 051421200 DRAWN BY 8 DIT W.C.L. 9/11/01 CHECKED BY 8 DIT G.N. 9/11/01 DRK APPROVE'S DATE G.P.N. 9/11/01	
	WARNING 1 The export or re-export of this drawing or a product produced by this drawing is subject to U.S. Export Administration regulations and other applicable governmental restrictions or regulations.	TITLE ELECT. SCHEMATIC, SL4K, 240V PANEL FULL VOLTAGE START	DRW. NO. 80070642D	TITLE BLOCK NUMBER 1 SHEET 3 OF 5	

1 2 3 4 5 6 7 8 9

REV. NO.		DESCRIPTION		DATE	APPROVED
1	REVISED PER REV01825			11/7/02	11/7/02

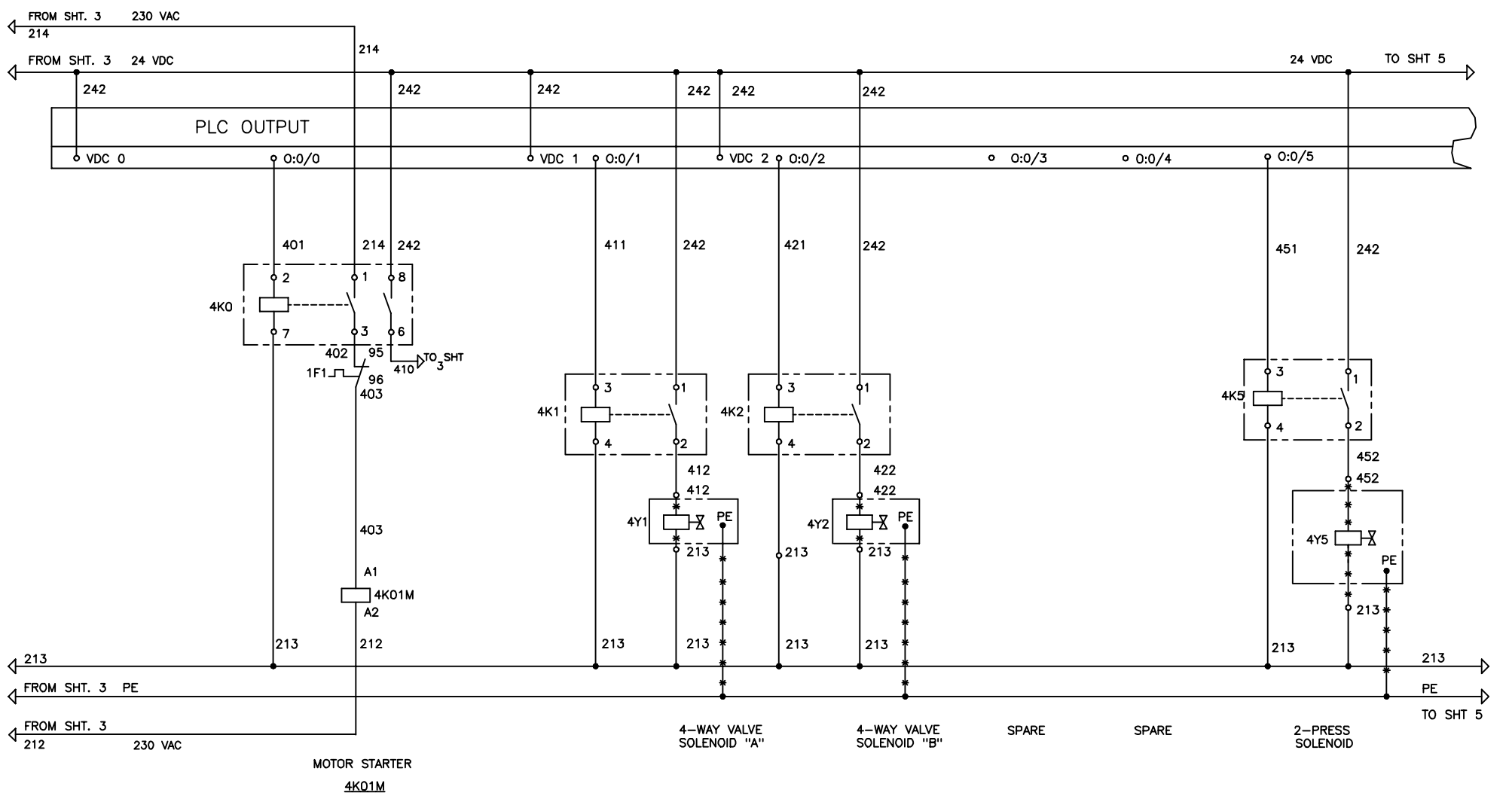

----- WIRING BY CUSTOMER IN ACCORDANCE WITH LOCAL REGULATIONS
 --*-* WIRING BY I-R EXTERNAL TO PANEL
 ALL AC CONTROL VOLTAGE WIRES MUST BE RED IN COLOR

Copyright © 2001 Ingersoll-Rand Company All Rights Reserved WARNING 1 The export or transport of this drawing or a product produced by this drawing is subject to U.S. Export Administration regulations and other applicable governmental restrictions or regulations.	PROPRIETARY NOTICE This document contains confidential and trade secret information, is the property of Ingersoll-Rand Co. and is given to the recipient in confidence. The recipient for recipient and release of this document except the document is confidential and against the interest as indicated in writing by Ingersoll-Rand Co. If an (1) is on the document or any copy thereof or the confidential or the trade secret information therein (2) is not on the document or any copy thereof, the recipient shall not disseminate, use, or otherwise make available the confidential or the trade secret information to anyone without the prior written consent of Ingersoll-Rand Co. If the recipient is a government agency, the recipient shall not disseminate, use, or otherwise make available the confidential or the trade secret information to anyone without the prior written consent of Ingersoll-Rand Co. If the recipient is a government agency, the recipient shall not disseminate, use, or otherwise make available the confidential or the trade secret information to anyone without the prior written consent of Ingersoll-Rand Co.	STANDARD TOLERANCES: UNLESS OTHERWISE NOTED: ALL DIMENSIONS ON DRAWING CONTINUE UNLESS OTHERWISE SPECIFIED TO JOB HOLE SIZE - .0005 SURFACE FINISH - ✓ STANDARD TOLERANCES: X1 = ±.003 X2 = ±.015 X3 = ±.005 ANGLE = ±.5°	GD&T TO ASME Y14.5M 1994 ALL DIMENSIONS IN INCHES (mm) UNLESS OTHERWISE SPECIFIED DIMENSIONAL TOLERANCES SURFACE FINISH DIMENSIONAL TOLERANCES SURFACE FINISH	REV. NO. 001421200 DRAWN BY: W.C.L. CHECKED BY: G.N.L. DATE: 9/11/01 DATE: 9/11/01 DATE: 9/11/01	
		TITLE: ELECT. SCHEMATIC, SL4K, 240V PANEL FULL VOLTAGE START PART NO.: 80070642D SHEET: 4 OF 5			

1 2 3 4 5 6 7 8 9

REVISONS			
ID	DESCRIPTION	DATE	APPROVED
1	REVISED PER REV01826	11/7/02 BR	11/7/02 GPA
2	A & B WERE 1 & 2, REV01831	1/21/03 BR	1/21/03 GPA

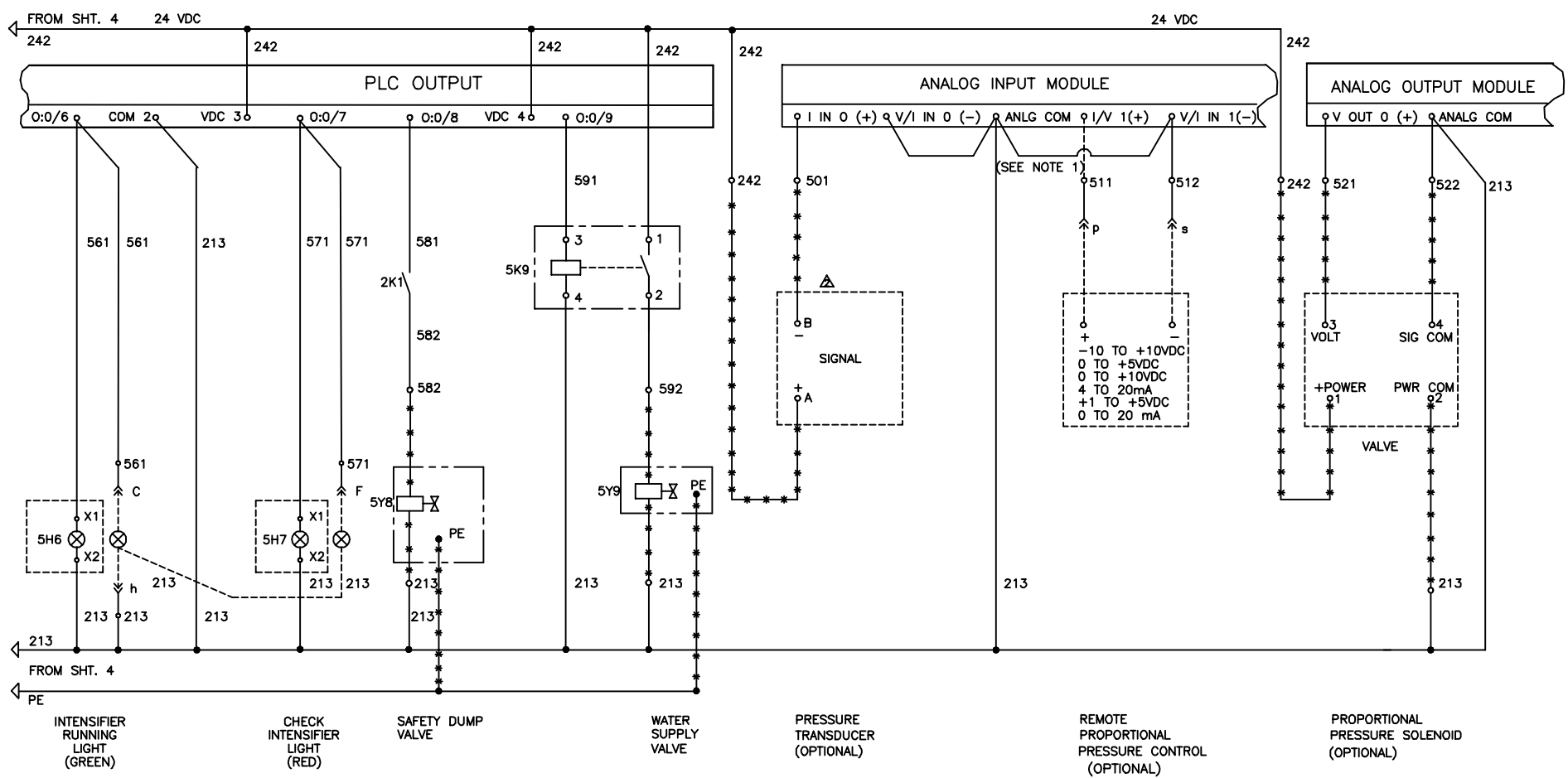

NOTE 1: VOLTAGE OR CURRENT CONTROL SPECIFIED BY CUSTOMER.
USE I IN 1(+) FOR CURRENT OR V IN 1(+) FOR
VOLTAGE CONTROL ON ANALOG MODULE.

----- WIRING BY CUSTOMER IN ACCORDANCE WITH LOCAL REGULATIONS

----* WIRING BY I-R EXTERNAL TO PANEL

ALL AC CONTROL VOLTAGE WIRES MUST BE RED IN COLOR

Copyright © 2001 Ingersoll-Rand Company All Rights Reserved WARNING ! The export or re-export of this drawing or a product produced by this drawing is subject to U.S. Export Administration regulations and other applicable governmental restrictions or regulations.	PROPRIETARY NOTICE This document contains confidential and trade secret information, is the property of Ingersoll-Rand Co., and is given to the recipient in confidence. The recipient by receipt and relation of the document accepts the document in confidence and agrees that, except as authorized in writing by Ingersoll-Rand Co., it will (1) not use the document or any copy thereof or the confidential or trade secret information therein; (2) not copy the document; and (3) upon completion of the need to review the document, or upon demand, return the document, all copies thereof, and all material copies thereof.	STANDARD TOLERANCES UNLESS OTHERWISE NOTED: ALL DIMENSIONS ON COORDINATE SYSTEMS SHALL BE CONFORM TO ASME BREAK SHARP EDGES AND CORNERS .015 SURFACE FINISH - ✓ STANDARD TOLERANCES: X.X - 0.003 X.XX - 0.010 X.XXX - 0.005 ANGLE = 32°	GD&T TO ASME Y14.5M 1994 REF. DIM = 051421200 DATE BY & DATE W.C.L. 9/11/01 CHECKED BY DATE G.N. 9/11/01 DIM. APPROVED & DATE G.P.N. 9/11/01	
	FILE ELECT. SCHEMATIC, SL4K, 240V PANEL FULL VOLTAGE START DIM. NO. 80070642D SHEET 5 OF 5			

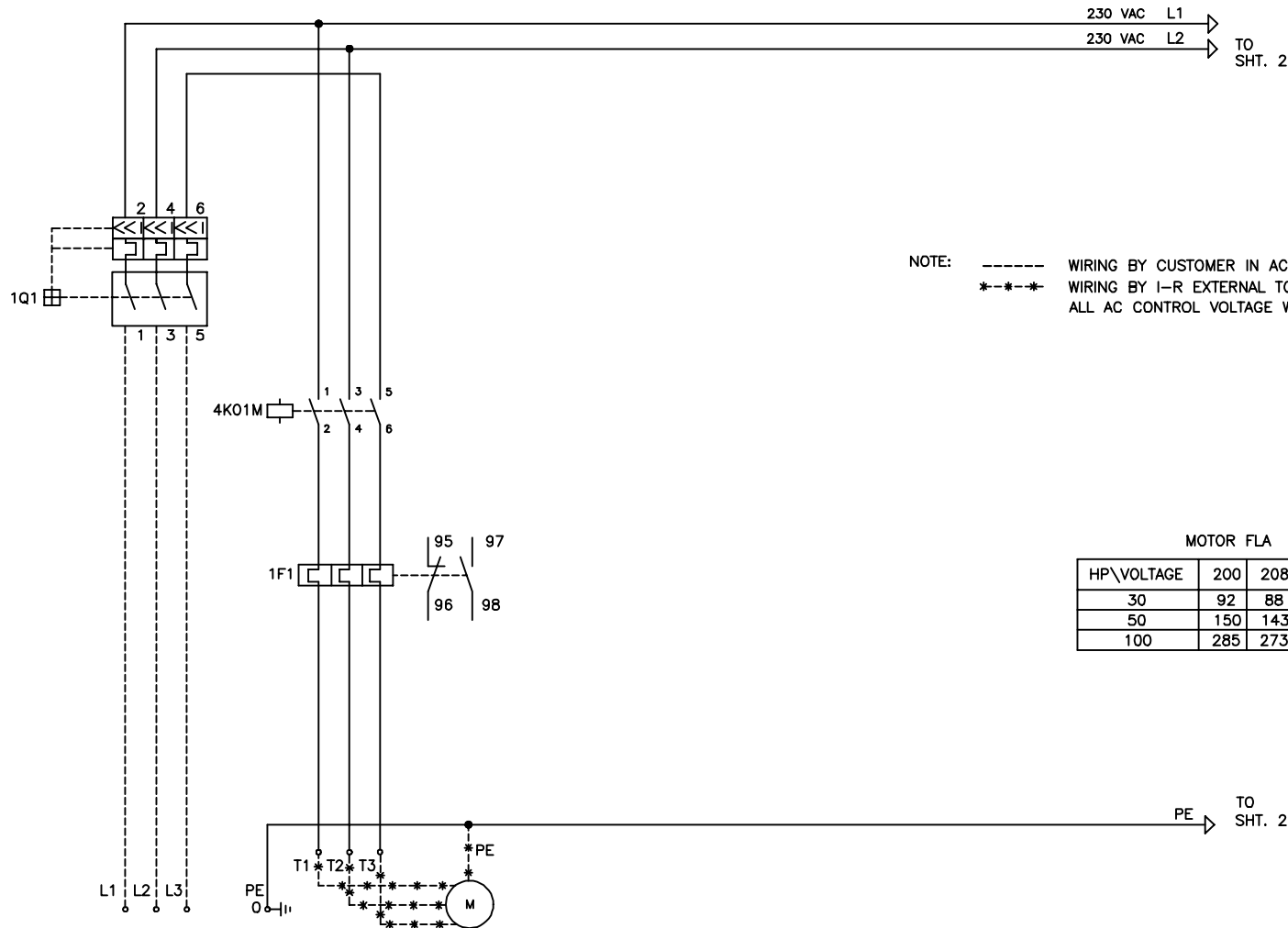

MOTOR FLA

HP\VOLTAGE	200	208	230	400	415	460	575
30	92	88	80	46	44	40	32
50	150	143	130	75	72	65	52
100	285	273	248	143	138	124	99

NOTE: ----- WIRING BY CUSTOMER IN ACCORDANCE WITH LOCAL REGULATIONS.
 --*-* WIRING BY I-R EXTERNAL TO PANEL
 ALL AC CONTROL VOLTAGE WIRES MUST BE RED IN COLOR

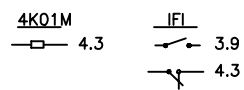

REF ASSEMBLY

Copyright © 2001 Ingersoll-Rand Company All Rights Reserved WARNING ! The report or receipt of this drawing or a product produced by this drawing is subject to U.S. Export Administration regulations and other applicable governmental restrictions or regulations.	PROPRIETARY NOTICE This document contains confidential and trade secret information, is the property of Ingersoll-Rand Co., and is given to the receiver in confidence. The receiver by receipt and retention of the document accepts the document in confidence and agrees that, except as authorized in writing by Ingersoll-Rand Co., it will not use the document or any information thereon, (2) not copy the document or any information thereon, (3) not disclose the document or any information thereon to any third party, and (4) upon completion of the need to retain the document, or upon demand, return the document, all copies thereof, and all material copied therefrom.	STANDARD TOLERANCES (UNLESS OTHERWISE NOTED) ALL DIMENSIONS ON COMMON EXPLOSIVE COPIES TO JOB BREAK SWEEP EDGES AND CORNERS 20° SURFACE FINISH - ✓ STANDARD TOLERANCES XX = ±.005 XXX = ±.015 XXXX = ±.030 ANGLE = ±.5°	GD&T TO ASME Y14.5M 1994 ALL DIMENSIONS IN INCHES (mm) DIM BY DATE W.C.L. 9/11/01 DIM BY DATE G.H. 9/11/01 DIM APPROVE DATE G.P.N. 9/11/01		REV. NO. 051421200 DATE 9/11/01 TITLE ELECT. SCHEMATIC, SL4K, 240V PANEL FULL VOLTAGE START
					TITLE BLOCK REVISION 1 SHEET 1 OF 5

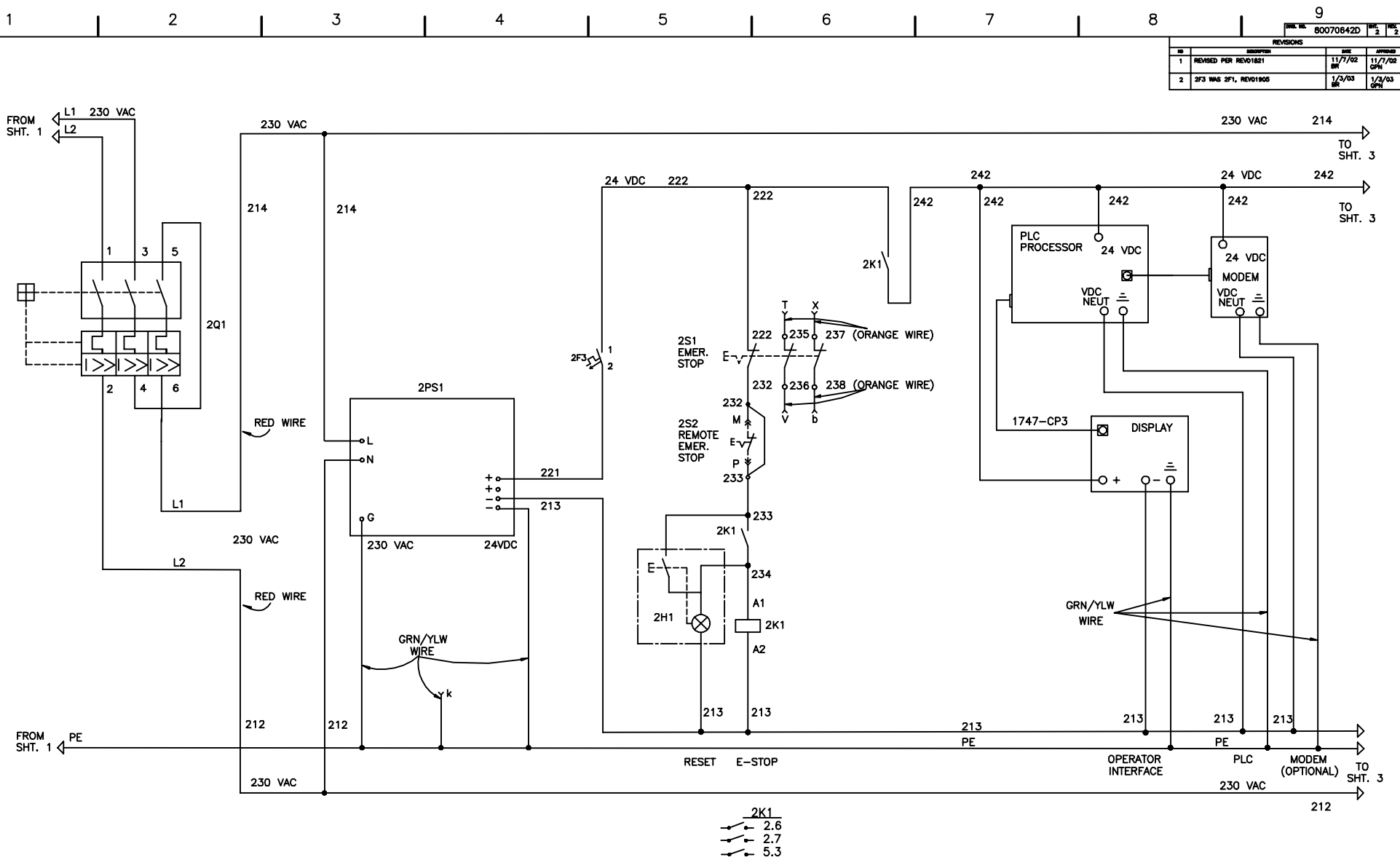

REV. NO. 80070642D			
REVISIONS			
NO.	DESCRIPTION	DATE	APPROVED
1	REVISED PER REV01821	11/7/02 BR	11/7/02 GPN
2	2F3 WAS 2F1, REV01805	1/3/03 BR	1/3/03 GPN

NOTE: ----- WIRING BY CUSTOMER IN ACCORDANCE WITH LOCAL REGULATIONS.
 ------* WIRING BY I-R EXTERNAL TO PANEL
 ALL AC CONTROL VOLTAGE WIRES MUST BE RED IN COLOR

Copyright © 2001 Ingersoll-Rand Company All Rights Reserved	PROPRIETARY NOTICE	STANDARD TOLERANCES	GD&T TO ASME Y14.5M 1994	
	This document contains confidential and trade secret information, is the property of Ingersoll-Rand Co., and is given to the recipient in confidence. The recipient is notified and retention of the document conveys the document in confidence and agrees that, except as authorized in writing by Ingersoll-Rand Co., it will (1) not use the document or any part thereof or (2) not cause the document (2) not disclose its contents to others, (3) not disseminate or trade information therefrom, and (4) upon completion of the work to return the document, or if not returned, return the document, all copies thereon, and all material copied therefrom.	UNLESS OTHERWISE NOTED: ALL DIMENSIONS ON COMMON CENTERLINE UNLESS OTHERWISE NOTED: BREAK SHARP EDGES AND CORNERS .015 SURFACE FINISH: - .7 LEADLINE TOLERANCES: .XX = ±.003 .XXX = ±.015 .XXXX = ±.005 ANGLE = ±2°	ALL DIMENSIONS IN INCHES [mm] REF. DIM. 05142120D DIM. OF A DIM. W.C.L. 9/11/01 DIMENSION OF A DIM. G.N. 9/11/01 DIM. APPROX. & DIM. G.P.N. 9/11/01	