

5th AXIS[®]

Workholding Evolved.

VOLUME **3**

VISES - FIXTURES - QUICK CHANGE SYSTEMS

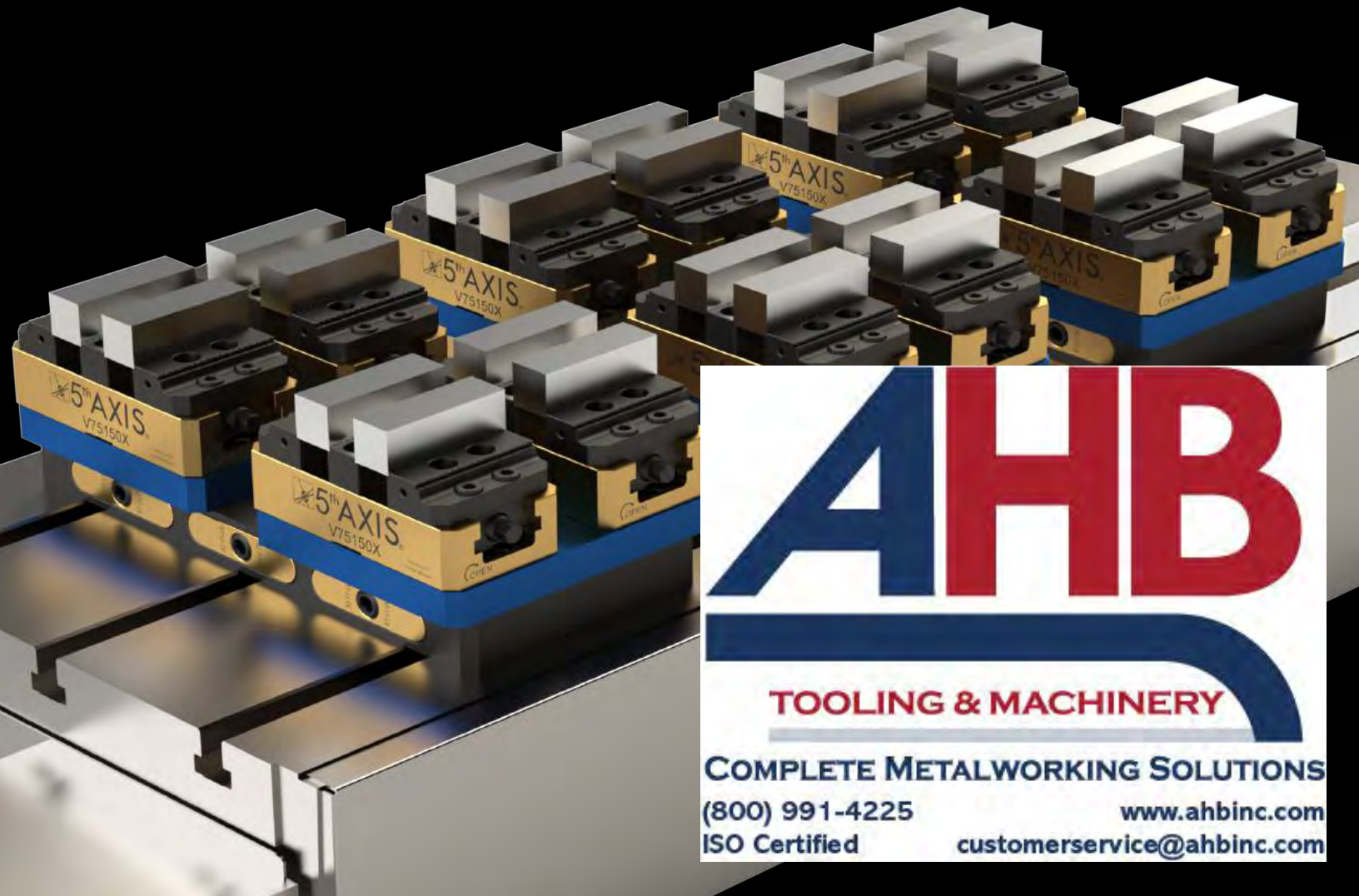

AHB

TOOLING & MACHINERY

COMPLETE METALWORKING SOLUTIONS

(800) 991-4225

www.ahbinc.com

ISO Certified

customerservice@ahbinc.com

Maximum efficiency with 52mm

ROCKLOCK™ QUICK CHANGE SYSTEM



Reduce Setup and Changeover Time



Simple Modular Design



Solutions Available for 3, 4, & 5 Axis Machines

Small Vise

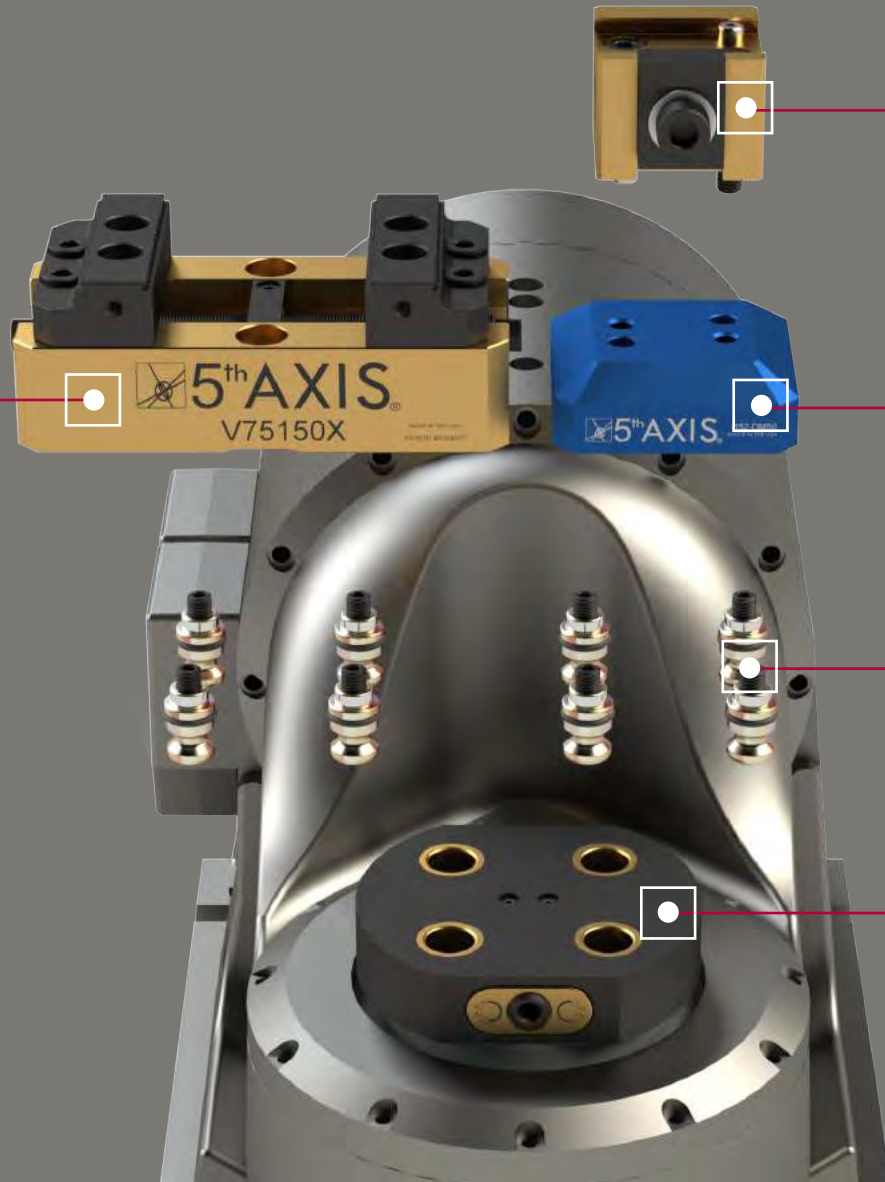

Top Tooling Fixture

Adapter

PS16F

Base



Repeatability less than .0003"



Industry standard 52mm pull stud spacing



Steel or aluminum body construction

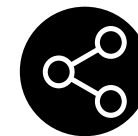

52mm Pull Stud Spacing



Robust Single Actuation Screw



Steel Locating Features

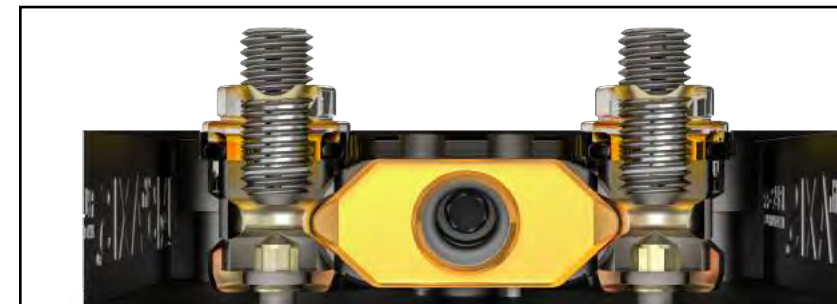

Patented free float design ensures equal force on all 4 pull studs. Compatible with other 52mm 4 pull stud systems. Simply change out the pull studs to ensure that the manufacturer's base plate and pull studs match.

Double Station Vises

Part Number	DV75150X-J1	DV75150X-J2	DV75150X-J3
			
Fixture Size	75mm x 150mm x 56mm	75mm x 150mm x 64.1mm	75mm x 150mm x 64.1mm
Jaw Width	75mm	75mm	75mm
Jaw Set	Hardened Steel 3 Piece Master Jaw Set Serrated Dovetail	6061 Aluminum Machinable Jaw Set	1018 Steel Machinable Jaw Set
Vise Type	Double Station	Double Station	Double Station
Compatible Pull Studs	4x PS16F (Sold separately)	4x PS16F (Sold separately)	4x PS16F (Sold separately)
Additional Vise Specs	See Page 39	See Page 39	See Page 39







Self-Centering Vises and Round Bar Fixture

Part Number	V75100X	V75150X	R52-CER40
			
Size	75mm x 100mm x 56mm	75mm x 150mm x 56mm	2.95" x 2.95" x 2.67"
Jaw Width	75mm	75mm	Utilizes Standard ER40 Collet Nut
Fixture	V75100X	V75150X	CER40
Overall Clamping Range	0 - 76.3mm	0 - 128.8mm	Accepts Only ER40 Size Collet
Vise Type	Self-Centering	Self-Centering	Round Bar Fixture
Compatible Pull Studs	4x PS16F (Sold separately)	4x PS16F (Sold separately)	4x PS16F (Included)
Additional Vise Specs	See Page 45	See Page 45	See Page 59

Metric Dovetail Fixtures

Part Number	R52-DM12	R52-2DM12	R52-P12DM12	R52-DM25	R52-P4DM25	R52-DM50
						
Size	75mm x 75mm x 51mm	75mm x 75mm x 51mm	125.73mm x 125.73mm x 133.5mm	75mm x 75mm x 55mm	Ø152.4mm x 64.9mm	75mm x 75mm x 63mm
Fixture	DM12	2x DM12	12x DM12	DM25	4x DM25	DM50
Stock	12mm and Above	12mm and Above	12mm and Above	25mm and Above	25mm and Above	50mm and Above
Compatible Pull Studs	4x PS16F (Included)	4x PS16F (Included)	4x PS16F (Included)	4x PS16F (Included)	4x PS16F (Included)	4x PS16F (Included)
Additional Fixture Specs	See Page 53	See Page 53	See Page 57	See Page 53	See Page 58	See Page 53

Inch Dovetail Fixtures

Part Number	R52-D05125	R52-2D05125	R52-P12D05125	R52-D115	R52-P4D115	R52-D22
						
Size	2.95" x 2.95" x 2"	2.95" x 2.95" x 2"	4.95" x 4.95" x 5.26"	2.95" x 2.95" x 2.175"	Ø6" x 2.55"	2.95" x 2.95" x 2.5"
Fixture	D05125	2x D05125	12x D05125	D115	4x D115	D22
Stock Width	.5" and Above	.5" and Above	.5" and Above	1" and Above	1" and Above	2" and Above
Compatible Pull Studs	4x PS16F (Included)	4x PS16F (Included)	4x PS16F (Included)	4x PS16F (Included)	4x PS16F (Included)	4x PS16F (Included)
Additional Fixture Specs	See Page 54	See Page 54	See Page 57	See Page 54	See Page 58	See Page 55

Low Profile Adapters

Part Number	RL52A-4 RL52S-4	RL52A-4-96 RL52S-4-96	RL52A-4-TRT100
Size	Ø116mm x 25mm	Ø116mm x 25mm	Ø116mm x 25mm
Subcategory	Low Profile Adapter	Low Profile Adapter	Low Profile Adapter
Materials	Aluminum (RL52A-4) or Steel (RL52S-4)	Aluminum (RL52A-4-96) or Steel (RL52S-4-96)	Aluminum (RL52A-4-TRT100)
Mounting	Drill Your Own @ 50mm-100mm*	2x M10 or 3/8" SHCS @ 96mm	HAAS TRT 100
Additional RockLock Specs	See Page 6	See Page 6	See Page 6

Low Profile Adapters and Integrated Tombstone

Part Number	RL52A-44 RL52S-44	RL52A-4560 RL52S-4560	RL52A-A96	RL52A-T31
Size	103.5mm x 103.5mm x 25mm	122.0mm x 102.1mm x 25mm	124.0mm x 124.0mm x 25mm	Ø160mm x 167mm
Subcategory	Low Profile Adapter	Low Profile Adapter	96mm to 52mm Adapter	52mm Integrated Tombstone 96mm Base
Materials	Aluminum (RL52A-44) or Steel (RL52S-44)	Aluminum (RL52A-4560) or Steel (RL52S-4560)	Aluminum (RL52A-A96)	Aluminum (RL52A-T31)
Mounting	2x SB1210 (Included) and 2x M12 or 1/2" @ Ø82mm 90°	4x M10 or 3/8" @ Ø116mm 60°	96mm Spacing and Includes 4x PS20F	96mm Spacing and Includes 4x PS20F
Additional RockLock Specs	See Page 7	See Page 7	See Page 8	See Page 8

RL52A-4 / RL52S-4



Size: Ø116mm x 25mm
Bolt Pattern: Drill Your Own Custom @ 50mm-100mm
Material Construction: Aluminum (RL52A-4) Steel (RL52S-4)

This circular RockLock adapter is built for small and medium sized rotaries and trunnions with 50mm to 100mm bolt circle.

Repeatability of +/- 0.0003".

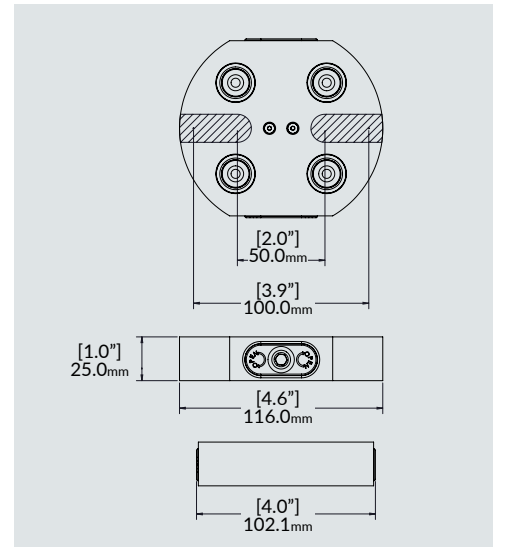

RL52A-4-96 / RL52S-4-96



Size: Ø116mm x 25mm
Bolt Pattern: 2x M10 or 3/8" SHCS @ 96mm
Material Construction: Aluminum (RL52A-4-96) Steel (RL52S-4-96)

This circular RockLock adapter is built for small and medium sized rotaries and trunnions with 96mm bolt circle.

Repeatability of +/- 0.0003".

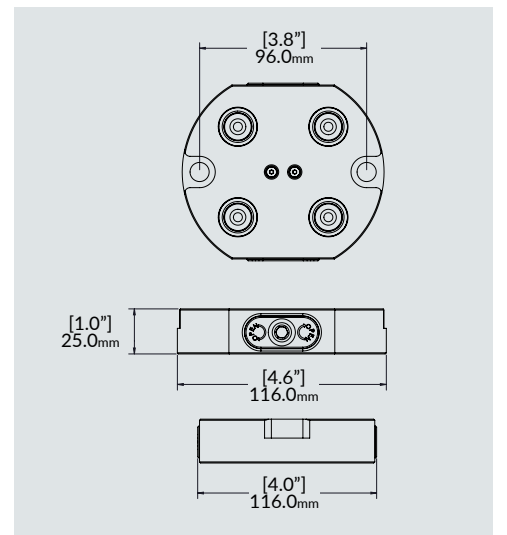

RL52A-4-TRT100



Size: Ø116mm x 25mm
Bolt Pattern: 2x 5/16" @ 82.98mm
Material Construction: Aluminum (RL52A-4-TRT100)

This circular RockLock adapter is built for the Haas TRT100 trunnion.

Repeatability of +/- 0.0003".

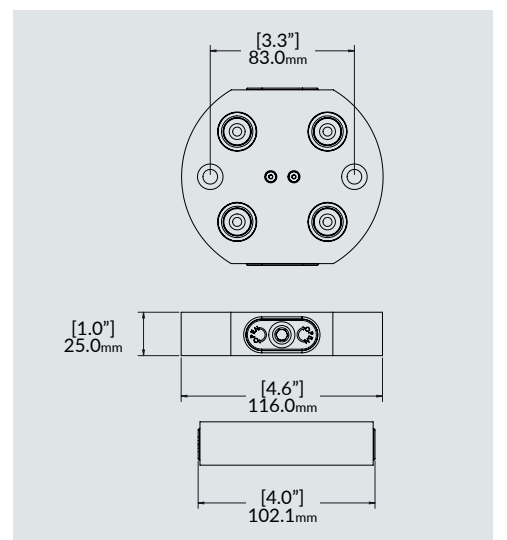

52mm RockLock

52mm RockLock

**RL52A-44 /
RL52S-44**



Size: 103.5mm x 103.5mm x 25mm
Spacing: 2x SB1210 (Included) and 2x M12 or 1/2" @ Ø82mm 90°. Through hole Ø12.02mm
Material Construction:
 Aluminum (RL52A-44)
 Steel (RL52S-44)

This square low profile adapter is built for custom tombstones.

Ships with 2x shoulder bolts (SB1210) for locating.

Repeatability of +/- 0.0003".

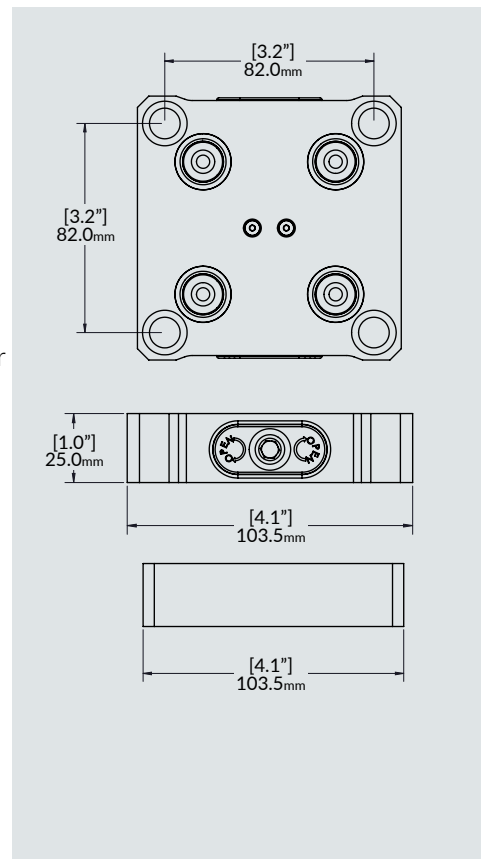

**RL52A-4560 /
RL52S-4560**



Size: 122.0mm x 102.1mm x 25.0mm
Spacing: 4x M10 or 3/8" @ Ø116mm
Material Construction:
 Aluminum (RL52A-4560)
 Steel (RL52S-4560)

This rectangular low profile adapter is built for small and medium sized rotaries with 60-degree T-slot spacing.

Ships with 2x rounded T-Slot nuts (14mm x M10) for maximum bolt circle capability.

Repeatability of +/- 0.0003".

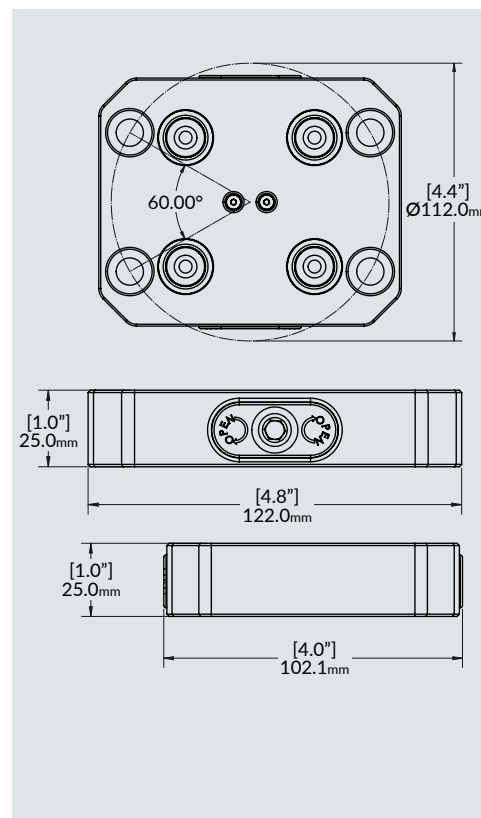

RL52A-A96



Size: 124.0mm x 124.0mm x 25.0mm
Bolt Pattern: 96mm Spacing and Includes 4x PS20F
Material Construction:
 Aluminum (RL52A-A96)

The RL52A-A96 allows for the quick and easy conversion between the 96mm system and the 52mm system.

96mm spacing on the bottom of the unit and the integrated 52mm system on the top quickly adapts 52mm top tooling to the 96mm risers and adapters.

The unit includes 4x PS20F and 96mm RockLock pattern on the bottom for mounting to any RL96 base.

Repeatability of +/- 0.0003".

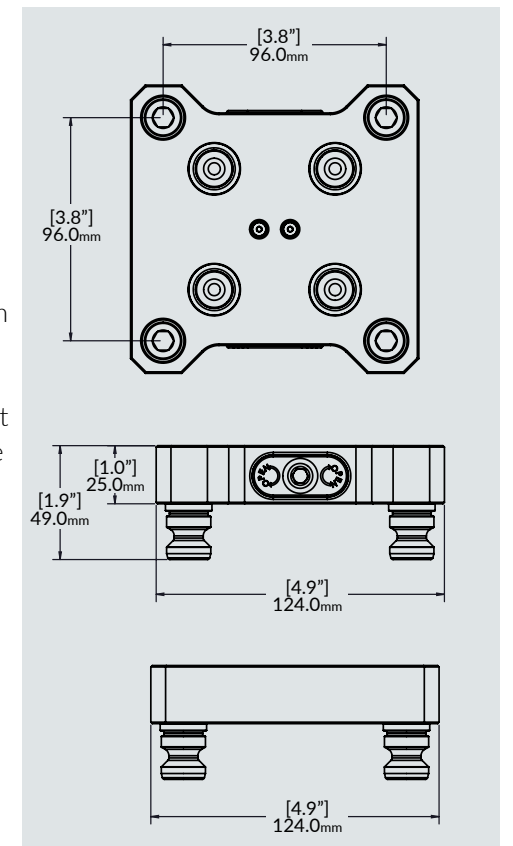

RL52A-T31



Size: Ø160mm X 167.0mm
Spacing: Includes 4x PS20F
Material Construction:
 Aluminum (RL52A-T31)

This 3-sided integrated RockLock tombstone can be mounted onto any RL96 base.

52mm spacing on the 3 faces of the tombstone. 96mm spacing on the bottom of the tombstone.

4x PS20F are included.

Repeatability of +/- 0.0003".

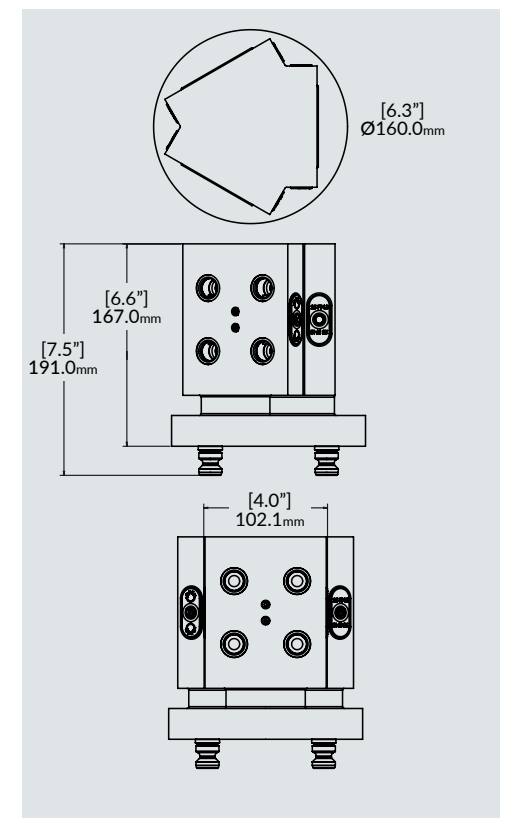

PS16F

PULL STUD

Size: 52mm Pull Studs

Material Construction: S7 Tool Steel



The PS16F is necessary to use any 5th Axis 52mm base. The 52mm spacing on 5th Axis vises and adapters allow for compatibility with other competitive systems.

*Please note that pull studs must stay with the corresponding company's base plate. If you are using a 5th Axis 52mm RockLock base plate you will need 5th Axis pull studs (PS16F). The spacing and thread allows for the top tooling to be interchangeable between the competitive systems.

PS16F-PY

SINGLE PULL STUD WITH POKA-YOKE INSERT

Size: 52mm Pull Studs

Material Construction: S7 Tool Steel



Poka-yoke is a Japanese term that means "mistake-proofing". The PS16F-PY is a single modified pull stud with aluminum ring. The ring is placed inside one of the locating holes in the RockLock base, allowing for only the single poka-yoke pull stud to fit inside the locating hole with the corresponding ring. This will prevent operators from changing the orientation and misloading a part.

PS16F-4PY

PULL STUDS WITH POKA-YOKE INSERT

Size: 52mm Pull Studs

Material Construction: S7 Tool Steel



3x Standard PS16F Pull Studs and one Poka-Yoke (PS16F-PY).



R52-BLANK

Size: 52mm Pull Studs

Material Construction: 6061 Aluminum

Blank 6061 aluminum block with 4x PS16F pull studs included. Quickly build your own fixture / subplate with the R52-Blank.

R52-HTS

Size: 52mm Pull Studs

Material Construction: 6061 Aluminum



Quick change adapter for the Renishaw OTS Tool Setter. Accurately remove and relocate the tool probe when its not in use. The part number includes the adapter plate + 4x PS16F pull studs.

*Requires any 52mm RockLock base unit.
**Tool setter sold separately.

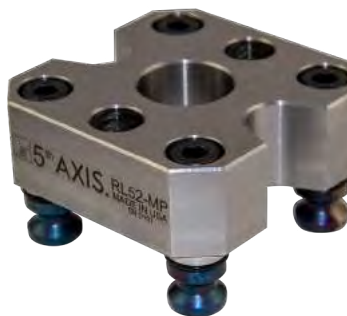

RL52-MP

52mm Master Pallet

Size: 52mm Pull Studs

Material Construction: 4140 Steel

Mount the RockLock base onto the machine, drop in the master pallet, dial in your setup, and torque your mounting bolts once you have reached the desired location. This is the fastest, most accurate way to set up the RockLock system. Use the bore to find center and the edge to set rotation.

See page 33 for more info.

Maximum efficiency with 96mm

ROCKLOCK™ QUICK CHANGE SYSTEM



96mm RockLock

Reduce Setup and Changeover Time

Simple Modular Design

Solutions Available for 3, 4, & 5 Axis Machines

Vise



PS20F



Base



ROCKLOCK™ QUICK CHANGE SYSTEM

■ Repeatability less than .0003"

■ Industry standard 96mm pull stud spacing

■ Steel or aluminum body construction

96mm RockLock



96mm Pull Stud Spacing



Robust Single Actuation Screw



Steel Locating Features

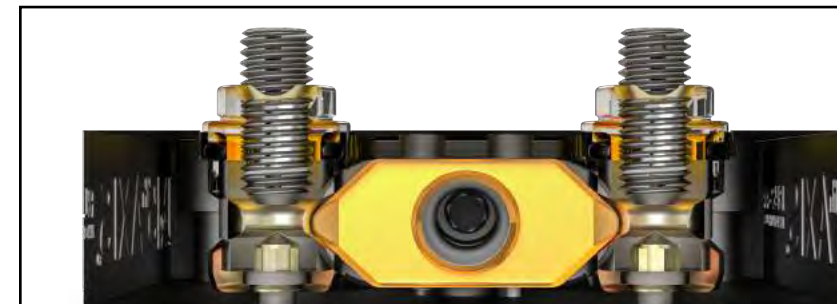

Patented free float design ensures equal force on all 4 pull studs. Compatible with other 96mm 4 pull stud systems. Simply change out the pull studs to ensure that the manufacturer's base plate and pull studs match.

RockLock 96mm Compatible Self-Centering Vises

Part Number	V552	V552M	V562	V562M	V510M	V6105	V6105M
Size	4.95" x 5.0" x 2.90"	125.7mm x 127mm x 73.6mm	4.95" x 6.0" x 2.90"	125.7mm x 152.4mm x 73.6mm	126mm x 152mm x 74mm	5.9" x 10.2" x 3.7"	150mm x 250mm x 94.1mm
Compatible Pull Studs	4x PS20F (Sold seperately)	4x PS20F (Sold seperately)	4x PS20F (Sold seperately)	4x PS20F (Sold seperately)	4x PS20F (Sold seperately)	4x PS20F (Sold seperately)	4x PS20F (Sold seperately)
Overall Clamping Range	0 - 5.16"	0 - 56.9mm	0 - 3.61"	0 - 153.6mm	0 - 254.8mm	0 - 10"	0 - 243.3mm
Additional Vise Specs	See Page 46	See Page 46	See Page 47	See Page 47	See Page 48	See Page 48	See Page 49

Part Number	R96-V75100X	R96-2V75100X	R96-V75150X	R96-2V75150X	R96-V75100T4	R96-V75XT4
Size	125mm x 125.73mm x 87.88mm	150mm x 176.53mm x 78.2mm	125.73mm x 151.13mm x 87.88mm	150mm x 176.53mm x 78.2mm	125.7mm x 125.7mm x 266.7mm	125.7mm x 125.7mm x 199.5mm
Vise	V75100X	2x V75100X	V75150X	2x V75150X	Compatible with V75100X (Vises Sold Separately)	Compatible with V75100X, V75150X, & DV75150X (Vises Sold Separately)
Vise Overall Clamping Range	0 - 76.3mm	N/A	0 - 128.8mm	N/A	N/A	N/A
Compatible Pull Studs	4x PS20F (Included)	4x PS20F (Included)	4x PS20F (Included)	4x PS20F (Included)	4x PS20F (Included)	4x PS20F (Included)
Vise Type	Self-Centering	Self-Centering	Self-Centering	Self-Centering	Self-Centering	Self-Centering or Double Station
Additional Vise Specs	See Page 45	See Page 45	See Page 45	See Page 45	See Page 26	See Page 26

RockLock 96mm Double Station Vises

Part Number	R96-DV75150X-J1	R96-2DV75150X-J1	DV56-J1	DV510-J1	DV510-J4
Size	125.73mm x 151.13mm x 87.88mm	150mm x 176.53mm x 78.2mm	125.7mm x 152.4mm x 72.9mm	125.7mm x 258.3mm x 73.4mm	125.7mm x 258.3mm x 73.4mm
Vise	DV75150X-J1	2x DV75150-J1	DV56-J1	DV510-J1	DV510-J4
Jaw Set	Hardened Steel 3 Piece Master Jaw Set	Hardened Steel 3 Piece Master Jaw Set	Hardened Steel 3 Piece Master Jaw Set	Hardened Steel 3 Piece Master Jaw Set with 2" Center	Hardened Steel 3 Piece Master Jaw Set with 1 inch center
Compatible Pull Studs	4x PS20F (Included)	4x PS20F (Included)	4x PS20F (Sold seperately)	4x PS20F (Sold seperately)	4x PS20F (Sold seperately)
Vise Type	Double Station	Double Station	Fixed Jaw / Double Station	Fixed Jaw / Double Station	Fixed Jaw / Double Station
Additional Vise Specs	See Page 39	See Page 39	See Page 40	See Page 41	See Page 41

Part Number	R96-DV75150X-J2	R96-2DV75150X-J2	DV56-J2	DV510-J2	R96-DV75150X-J3	R96-2DV75150X-J3	DV56-J3	DV510-J3
Size	125.73mm x 151.13mm x 87.88mm	150mm x 176.53mm x 78.2mm	125.7mm x 152.4mm x 89mm	125.7mm x 258.3mm x 88.5mm	125.73mm x 151.13mm x 87.88mm	150mm x 176.53mm x 78.2mm	125.7mm x 152.4mm x 89mm	125.7mm x 258.3mm x 88.5mm
Vise	DV75150-J2	2x DV75150-J2	DV56-J2	DV510-J2	DV75150-J3	2x DV75150-J3	DV56-J3	DV510-J3
Jaw Set	6061 Aluminum Soft Jaw Set	6061 Aluminum Soft Jaw Set	6061 Aluminum Soft Jaw Set	6061 Aluminum Soft Jaw Set	1018 Steel Machinable Jaws	1018 Steel Machinable Jaws	1018 Steel Machinable Jaws	1018 Steel Machinable Jaws
Compatible Pull Studs	4x PS20F (Included)	4x PS20F (Included)	4x PS20F (Sold seperately)	4x PS20F (Sold seperately)	4x PS20F (Included)	4x PS20F (Included)	4x PS20F (Sold seperately)	4x PS20F (Sold seperately)
Vise Type	Double Station	Double Station	Double Station	Double Station	Double Station	Double Station	Double Station	Double Station
Additional Vise Specs	See Page 39	See Page 39	See Page 40	See Page 41	See Page 39	See Page 39	See Page 40	See Page 41

Metric Dovetail Fixtures

Part Number	R96-DM12	R96-2DM12	R96-P12DM12	R96-DM25	R96-P4DM25	R96-DM50
Size	125.73mm x 125.73mm x 67.4mm	125.73mm x 125.73mm x 67.4mm	125.73mm x 125.73mm x 133.5mm	125.73mm x 125.73mm x 75.4mm	Ø152.4mm x 64.9mm	125.73mm x 125.73mm x 76.4mm
Fixture	DM12	2x DM12	12x DM12	DM25	4x DM25	DM50
Stock Width	Under 25mm	Under 25mm	Under 25mm	Under 75mm	Under 75mm	50mm and Above
Compatible Pull Studs	4x PS20F (Included)	4x PS20F (Included)	4x PS20F (Included)	4x PS20F (Included)	4x PS20F (Included)	4x PS20F (Included)
Additional Fixture Specs	See Page 53	See Page 53	See Page 57	See Page 53	See Page 58	See Page 53

Inch Dovetail Fixtures and Round Bar Fixture

Part Number	R96-D05125	R96-2D05125	R96-P12D05125	R96-D115	R96-3D115	R96-D115T41
Size	4.95" x 4.95" x 2.625"	4.95" x 4.95" x 2.625"	4.95" x 4.95" x 5.26"	4.95" x 4.95" x 3"	4.95" x 4.95" x 3"	4.95" x 4.95" x 4.2"
Fixture	D05125	2x D05125	12x D05125	D115	3x D115	4x D115
Stock Width	Under 1"	Under 1"	Under 1"	Under 3"	Under 3"	Under 3"
Compatible Pull Studs	4x PS20F (Included)	4x PS20F (Included)	4x PS20F (Included)	4x PS20F (Included)	4x PS20F (Included)	4x PS20F (Included)
Additional Fixture Specs	See Page 54	See Page 54	See Page 57	See Page 54	See Page 54	See Page 27

Part Number	R96-P4D115	R96-D115P	R96-3D115P	R96-D22	R96-D362	R96-CER40
Size	Ø6" x 2.55"	4.95" x 4.95" x 3"	4.95" x 4.95" x 3"	4.95" x 4.95" x 3"	4.95" x 4.95" x 2.225"	4.95" x 4.95" x 3.2"
Fixture	4x D115	D115P	3x D115P	D22	D362	CER40
Stock Width	Under 3"	Picatinny	Picatinny	2" and Above	3" and Above	Utilizes Standard ER40 Collet Nut
Compatible Pull Studs	4x PS20F (Included)	4x PS20F (Included)	4x PS20F (Included)	4x PS20F (Included)	4x PS20F (Included)	4x PS20F (Included)
Additional Fixture Specs	See Page 58	See Page 54	See Page 54	See Page 55	See Page 55	See Page 59

Low Profile Bases

Part Number	RL96A-56 RL96S-56	RL96A-6760 RL96S-6760	RL96A-6790 RL96S-6790	RL96A-67 RL96S-67	RL96S-67M	RL96A-MAM72 RL96S-MAM72	RL96A-DDR RL96S-DDR
Size	158mm x 126mm x 30mm	174mm x 158mm x 30mm	156mm x 158mm x 30mm	158mm x 176mm x 30mm	158mm x 176mm x 30mm	158mm x 126mm x 30mm	150mm x 158mm x 34.5mm
Subcategory	Low Profile Adapter	Low Profile Adapter	Low Profile Adapter	Low Profile Adapter	Low Profile Adapter	Low Profile Adapter	Low Profile Adapter
Materials	Aluminum (RL96A-56) or Steel (RL96S-56)	Aluminum (RL96A-6760) or Steel (RL96S-6760)	Aluminum (RL96A-6790) or Steel (RL96S-6790)	Aluminum (RL96A-67) or Steel (RL96S-67)	Steel (RL96S-67M)	Aluminum (RL96A-MAM72) or Steel (RL96S-MAM72)	Aluminum (RL96A-DDR) or Steel (RL96S-DDR)
Mounting	2x M12 or 1/2" SHCS @ 100mm - 101.6mm (4")	4x M12 or 1/2" @ Ø170.0mm 60°	4x M10 or 5/8" @ Ø184.5mm 90°	4x 1/2" SB @ 6.0" x 4.0"	4x M12 SB @ 150mm x 100mm	Matsuura MAM72	Fanuc DDR
Additional RockLock Specs	See Page 18	See Page 18	See Page 19	See Page 19	See Page 19	See Page 20	See Page 20

Risers

Part Number	RL96A-38	RL96A-411	RL96A-3915	RL96A-4816
Size	Ø 201.9mm x 75.0mm	Ø 276mm x 100mm	381mm x 230mm x 80mm	400mm x 200mm x 100mm
Subcategory	Single Position Riser	Single Position Riser	Multi-Position Riser	Multi-Position Riser
Materials	Aluminum (RL96A-38)	Aluminum (RL96A-411)	Aluminum (RL96A-3915)	Aluminum (RL96A-4816)
Mounting	4x 1/2-13 or M12 bolts @ 90° on Ø 178.0mm or 3x 1/2-13 or M12 bolts @ 120° on Ø 178.0mm	4x 1/2-13 or M12 bolts @ 90° on Ø 9.92"	4x 5/8-11 or M16 bolts @ 200mm square	4x @ 320mm x 160mm rectangle (80mm T-slots) or 4x @ 360mm x 126mm rectangle (63mm T-slots)
Additional RockLock Specs	See Page 21	See Page 21	See Page 22	See Page 22

Multi-Position Plates

Part Number	RL96A-3613S1	RL96A-3613S2	RL96A-3613S3
Size	158mm x 338mm x 30mm	158mm x 338mm x 30mm	158mm x 338mm x 30mm
Subcategory	Multi-Position Horizontal Plate	Multi-Position Horizontal Plate	Multi-Position Horizontal Plate
Materials	Aluminum (RL96A-3613S1)	Aluminum (RL96A-3613S2)	Aluminum (RL96A-3613S3)
Mounting	2x M12 or 1/2" SHCS @ 96mm or 250mm	4x M12 or 1/2" SHCS Equally Spaced @ 80mm	4x M12 or 1/2" SHCS Equally Spaced @ 100mm
Additional RockLock Specs	See Page 23	See Page 23	See Page 23

RL96A-56 / RL96S-56



Size: 158mm x 126mm x 30mm
Spacing: 2x M12 or 1/2" SHCS @ 100mm - 101.6mm (4")
Material Construction:
 Aluminum (RL96A-56)
 Steel (RL96S-56)

The adapter has two enlarged counterbores to allow mounting from 100mm to 101.6mm for M12 or 1/2-13 SHCS for simple mounting to T-slots.

Repeatability of +/- 0.0003".

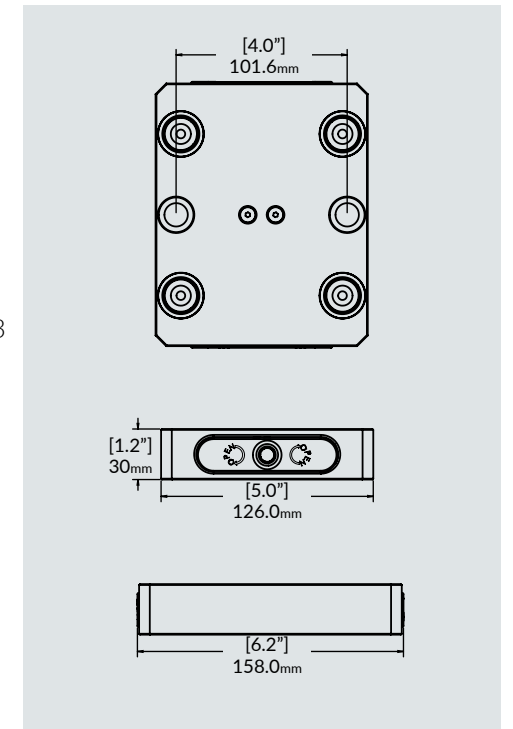

Tombstones, Right Angle Plate, and Single Position Riser

Part Number	RL96A-3002 RL96S-3002	RL96A-3003 RL96S-3003	RL96A-90DEG*	RL96A-356* RL96S-356*
Size	300mm x 300mm x 400mm	300mm x 300mm x 400mm	149.4mm x 158mm x 200mm	158mm x 126mm x 75mm
Subcategory	96mm Integrated Tombstone	96mm Integrated Tombstone	Right Angle Plate	Single Position Riser
Materials	Aluminum (RL96A-3002) or 1018 Steel (RL96S-3002)	Aluminum (RL96A-3003) or 1018 Steel (RL96S-3003)	Aluminum (RL96A-90DEG)	Aluminum (RL96A-356) or Steel (RL96S-356)
Mounting	Machine Specific*	Machine Specific*	4x PS20F (Included) or 2x M12 or 1/2" SHCS @ 100mm - 101.6mm (4")	4x PS20F (Included)
Additional RockLock Specs	See Page 24	See Page 24	See Page 25	See Page 26

RL96A-6760 / RL96S-6760



Size: 174mm x 158mm x 30mm
Spacing: 4x M12 or 1/2" @ Ø170.0mm 60°
Material Construction:
 Aluminum (RL96A-6760)
 Steel (RL96S-6760)

The RL96-6760 quick change adapter was built for the Haas TR-210 series rotaries, Hurco VMX30 series rotaries, and any other rotary with 60 degree radial T-slots.

A quick turn of the wrench actuates the cam mechanism to lock and release your fixtures and vises for fast changeover.

Repeatability of +/- 0.0003".

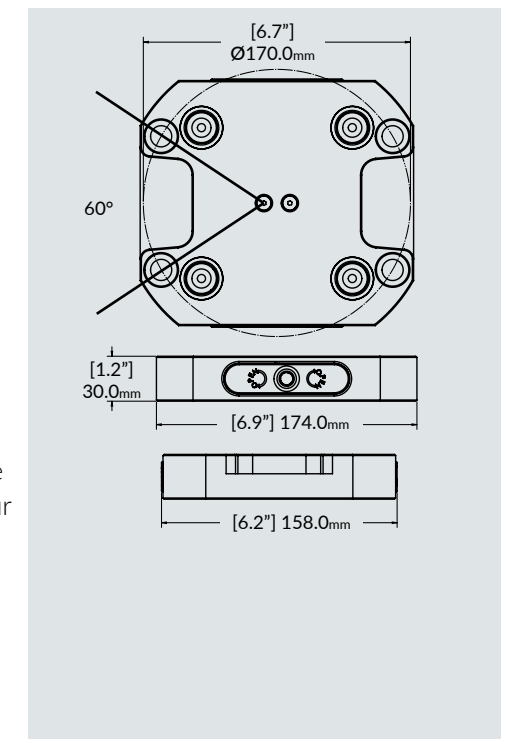

**RL96A-6790 /
RL96S-6790**



Size: 156mm x 158mm x 30mm
Spacing: 4x M10 or 5/8" @ Ø184.5mm
Material Construction:
 Aluminum (RL96A-6790)
 Steel (RL96S-6790)

The RL96-6790 quick change adapter was built for any rotary with 90 degree radial T-slots.

A quick turn of the wrench actuates the cam mechanism to lock and release your fixtures and vises for fast changeover.

Repeatability of +/- 0.0003".

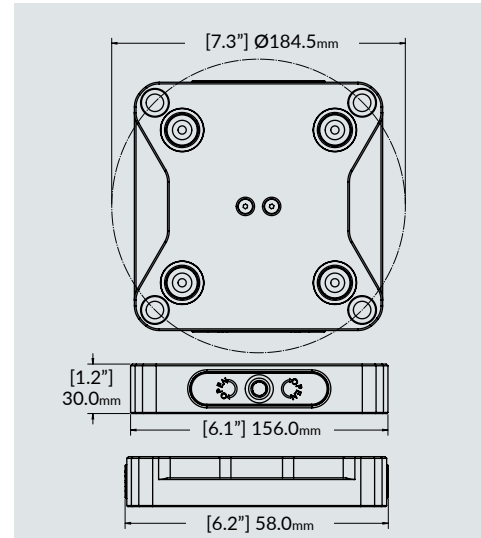

**RL96A-67 /
RL96S-67**



Size: 158.0mm x 176.0mm x 30mm
Spacing: 4x 1/2" SB @ 6.0" x 4.0".
 Through hole Ø0.501"
Material Construction:
 Aluminum (RL96A-67)
 Steel (RL96S-67)

The RL96-67 was built specifically for horizontal machining centers.

Bolt pattern 6.0" x 4.0" allows for easy mounting to most standard tombstone grid pattern spacing.

Repeatability of +/- 0.0003".

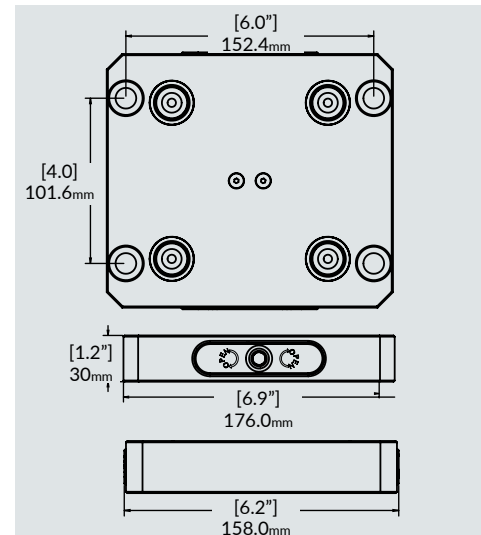

RL96S-67M



Size: 158.0mm x 176.0mm x 30mm
Spacing: 4x M12 @ 150.0mm x 100.0mm. Through hole Ø12.02mm
Material Construction:
 Steel (RL96S-67)

The RL96-67M was built specifically for tombstones on horizontal machining centers.

Bolt pattern 150mm x 100mm allows for easy mounting to most standard tombstone grid pattern spacing.

Repeatability of +/- 0.0003".

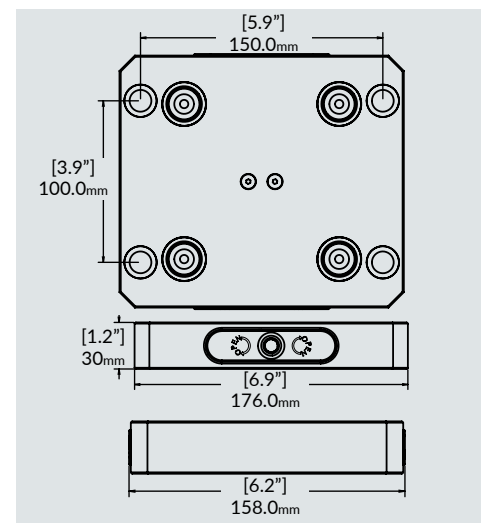

**RL96A-MAM72 /
RL96S-MAM72**



Size: 158mm x 126mm x 30mm
Spacing: Specific to MAM72
Material Construction:
 Aluminum (RL96A-MAM72)
 Steel (RL96S-MAM72)

The RL96-MAM72 quick change adapter was built for the standard Matsuura pallet and is compatible with the MAM72-25V, MAM72-35V, Cublex-25, Cublex-35, and MX-330.

Repeatability of +/- 0.0003".

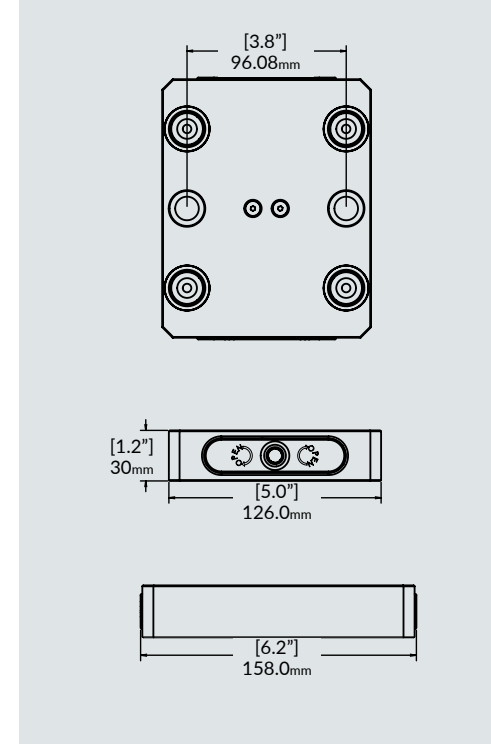

**RL96A-DDR /
RL96S-DDR**

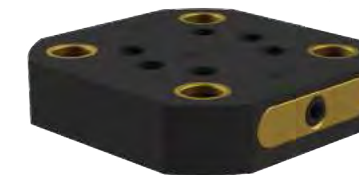

Size: 150mm x 158mm x 34.5mm
Spacing: Specific to DDR
Material Construction:
 Aluminum (RL96A-DDR)
 Steel (RL96S-DDR)

The RL96-DDR was built for the Fanuc DDR rotary table.

Repeatability of +/- 0.0003".

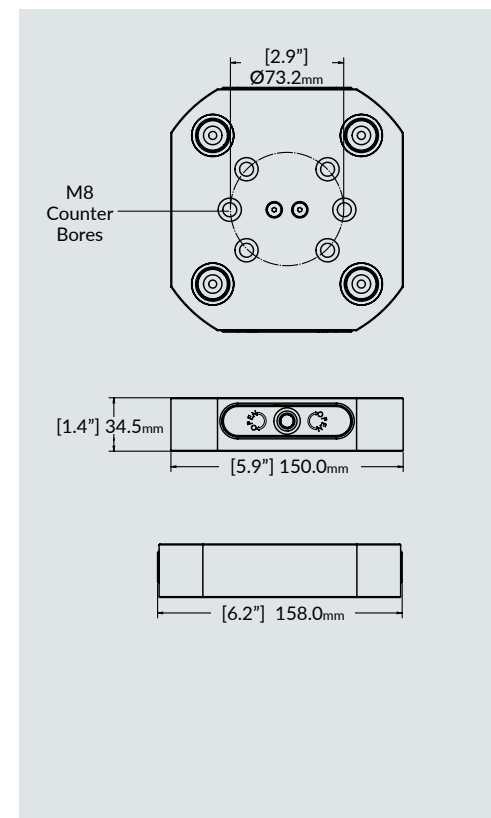

RL96A-38



Size: Ø 201.9mm x 75.0mm
Spacing:
 4x 1/2-13 or M12 bolts @ 90° on Ø 178mm or
 3x 1/2-13 or M12 bolts @ 120° on Ø 178mm
Material Construction:
 Aluminum (RL96A-38)

The RL96A-38 quick change adapter was built for medium sized rotaries and smaller 5 axis machines (~300 mm range).

With bolt patterns at 60 degrees and 90 degrees this adapter is flexible and fits on a majority of the most popular rotaries and 5 axis tables on the market.

The 3" overall height makes it ideal for those smaller parts that you want to get off the table.

Repeatability of +/- 0.0003".

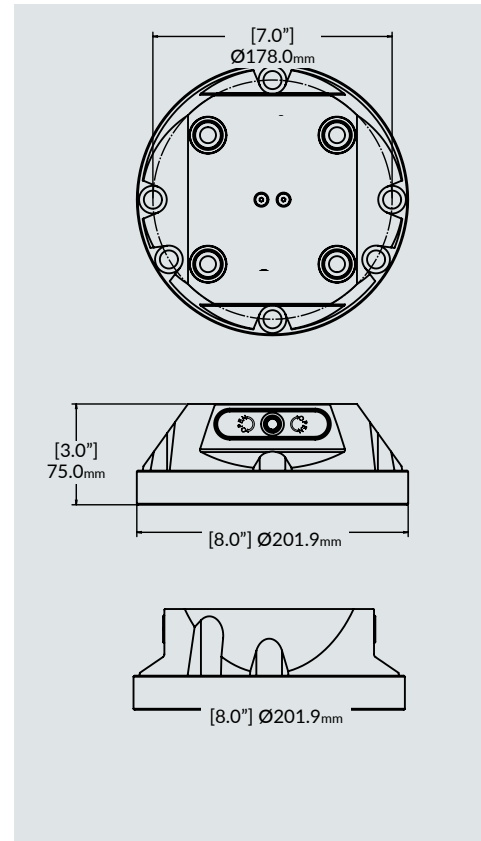

RL96A-411



Size: Ø 276mm x 100mm
Spacing:
 4x 1/2-13 or M12 bolts @ 90° on Ø 252.0mm or
 3x 1/2-13 or M12 bolts @ 120° on Ø 252mm
Material Construction:
 Aluminum (RL96A-411)

The RL96A-411 is an integrated RockLock riser built into one of our most popular adapters.

The 11" diameter adapter x 4" overall height is ideal for medium to large 5 axis machines like the DMG Mori DMU50 and DMU60 as well as the Haas UMC-750 and UMC-750SS.

Repeatability of +/- 0.0003".

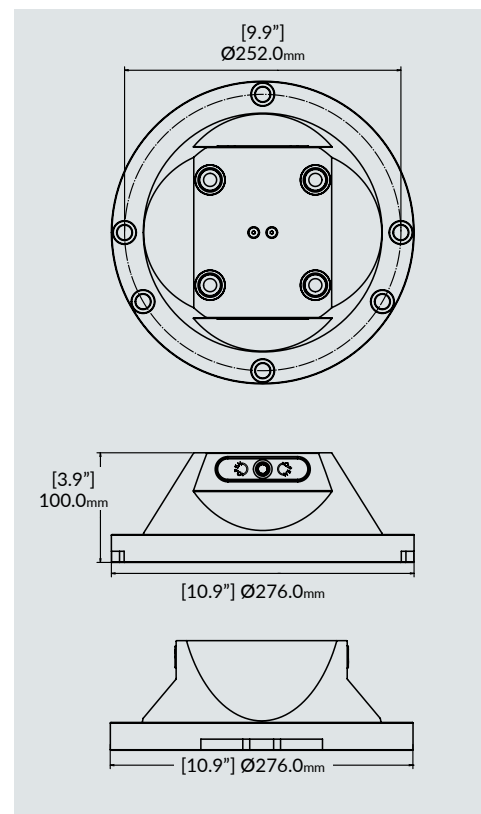

RL96A-3915



Size: 381mm x 230mm x 80mm
Spacing: 4x 5/8-11 or M16 bolts @ 200mm square
Material Construction:
 Aluminum (RL96A-3915)

The RL96A-3915 was built with larger machines in mind (400mm-500mm tables).

Utilize one singular large vise or accommodate two smaller workholding units to maximize machine efficiency and reduce changeover time.

Repeatability of +/- 0.0003".

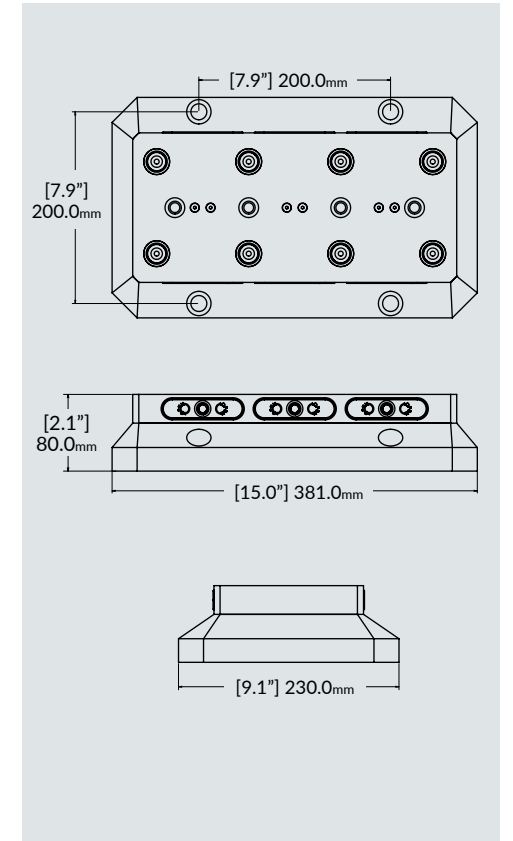

RL96A-4816



Size: 200mm x 400mm x 100mm
Spacing:
 4x @ 320mm x 160mm rectangle (80mm T-slots) or
 4x @ 360mm x 126mm rectangle (63mm T-slots)
Material Construction:
 Aluminum (RL96A-4816)

The RL96A-4816 is an integrated multi-position RockLock riser built into one unit. It is one of the largest adapters in the product line.

Utilize one large vise or accommodate two smaller vises with this riser.

Repeatability of +/- 0.0003".

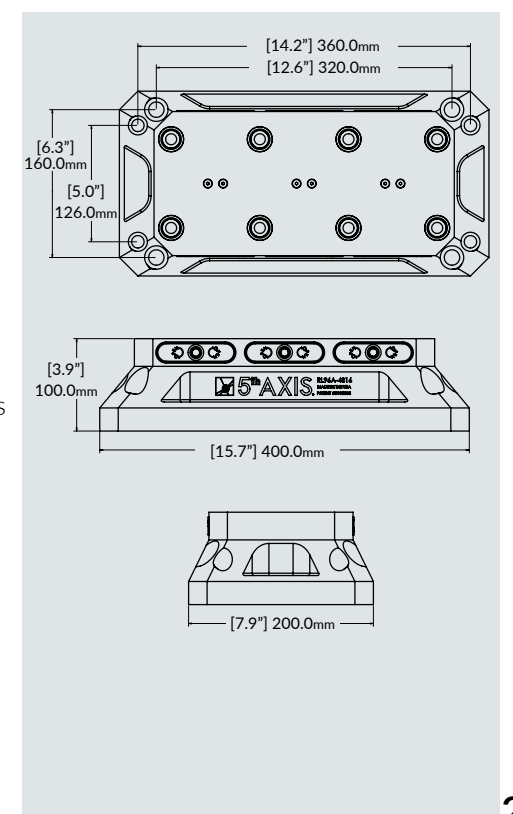

RL96A-3613S1

Size: 158mm x 338mm x 30mm
Spacing: 2x M12 or 1/2" SHCS @ 96mm or 250mm
Material Construction:
 Aluminum (RL96A-3613S1)

The RL96A-3613S1 is a multi-position RockLock plate built for maximum efficiency on small to medium vertical mills. The nested RockLock 96mm pattern allows for the operator to utilize one single large vise or two smaller vises. 125mm T-slot spacing for 3-axis mills. Repeatability of +/- 0.0003".

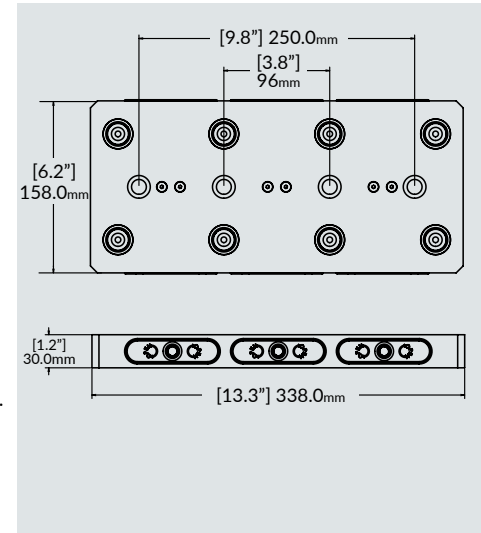

RL96A-3613S2

Size: 158mm x 338mm x 30mm
Spacing: 4x M12 or 1/2" SHCS Equally Spaced @ 80mm
Material Construction:
 Aluminum (RL96A-3613S2)

The RL96A-3613S2 is a multi-position RockLock plate built for maximum efficiency on small to medium vertical mills. The nested RockLock 96mm pattern allows for the operator to utilize one single large vise or two smaller vises. 80mm T-slot spacing for 3 axis mills. Repeatability of +/- 0.0003".

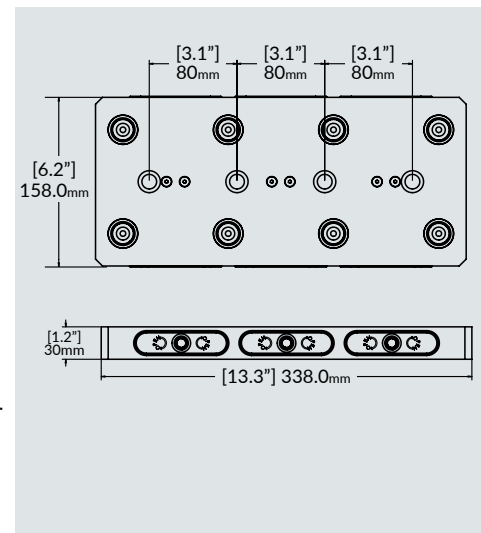

RL96A-3613S3

Size: 158mm x 338mm x 30mm
Spacing: 4x M12 or 1/2" SHCS Equally Spaced @ 100mm
Material Construction:
 Aluminum (RL96A-3613S3)

The RL96A-3613S3 is a multi-position RockLock plate built for maximum efficiency on small to medium vertical mills. The nested RockLock 96mm pattern allows for the operator to utilize one single large vise or two smaller vises. 100mm T-slot spacing for 3 axis mills. Repeatability of +/- 0.0003".

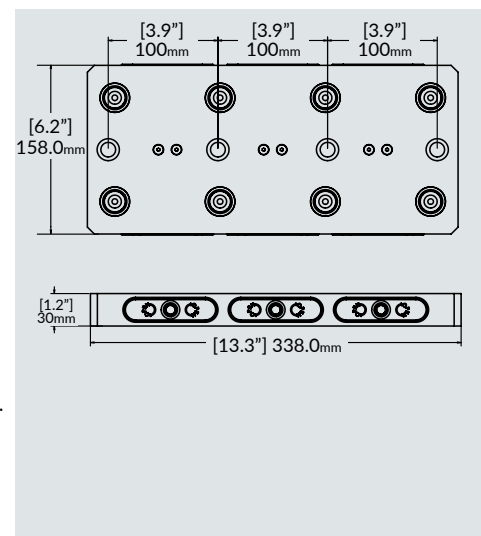

More Parts Per Cycle = More Profit Profitability Through Efficiency

3 Parts Per Cycle

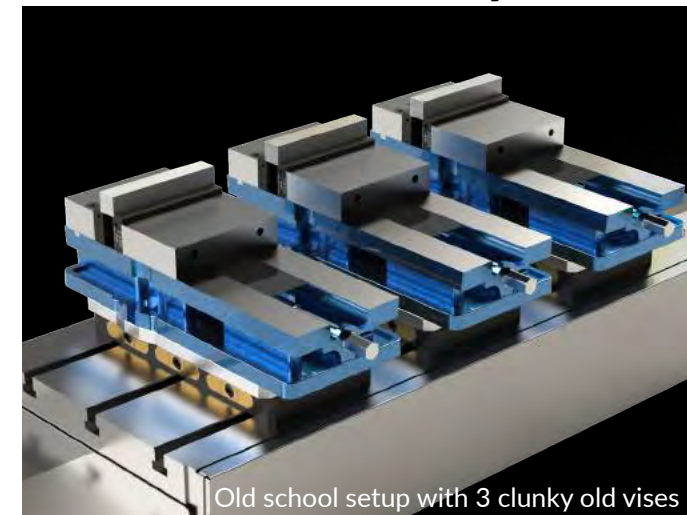

6 Parts Per Cycle

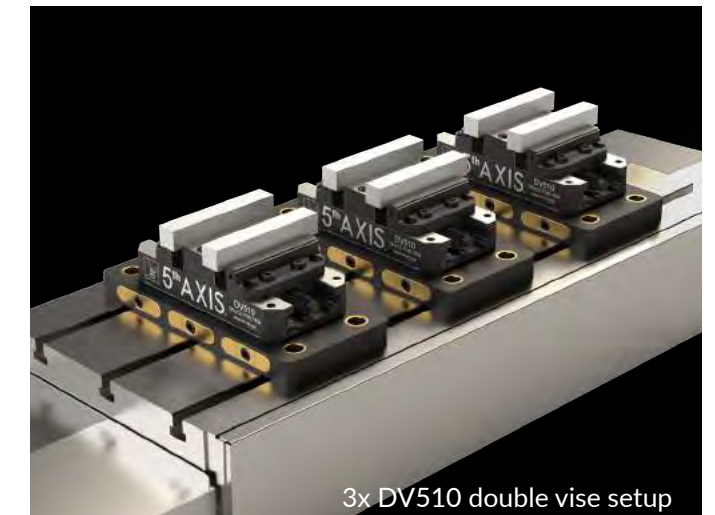

12 Parts Per Cycle

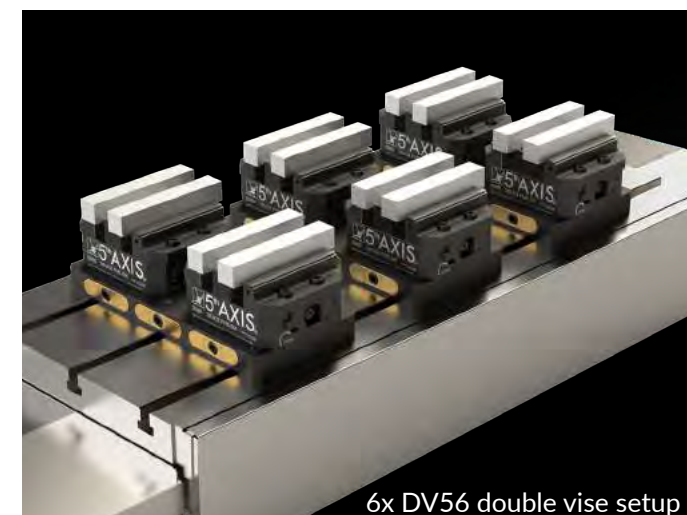

24 Parts Per Cycle

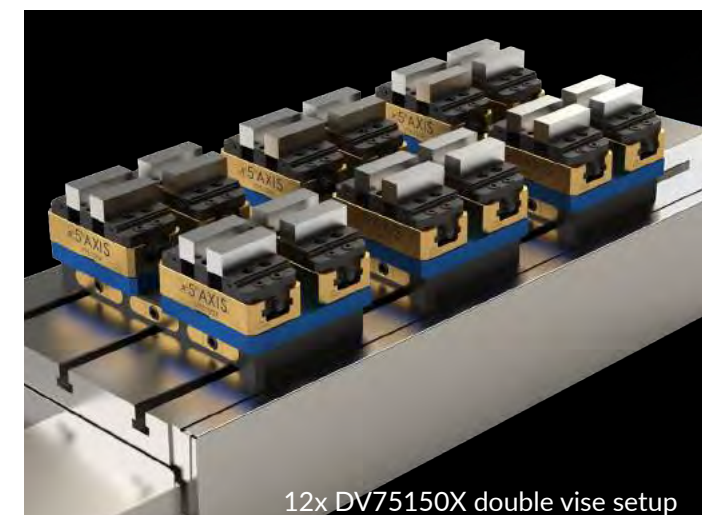

96mm RockLock

96mm RockLock

RL96A-3002 / RL96S-3002

Size: 300mm x 300mm x 400mm
Spacing: Custom
Material Construction:
 Aluminum (RL96A-3002)
 1018 Steel (RL96S-3002)

This two sided 300mm tombstone integrates the RockLock 96mm quick change system. This tombstone is perfect for mid-sized 5 Axis machines. It is also a perfect fit for 300mm horizontal machining centers offered by Kitamura and Kitagawa.

Tombstones can be ordered in aluminum or 1018 steel construction. All units feature hardened steel internals and locating features. All tombstones are built to order, and the base plate is customized to your machine table or pallet specs. 400mm and 500mm base versions are also available. Repeatability of +/- 0.0003".

Send us your table drawing for custom base.

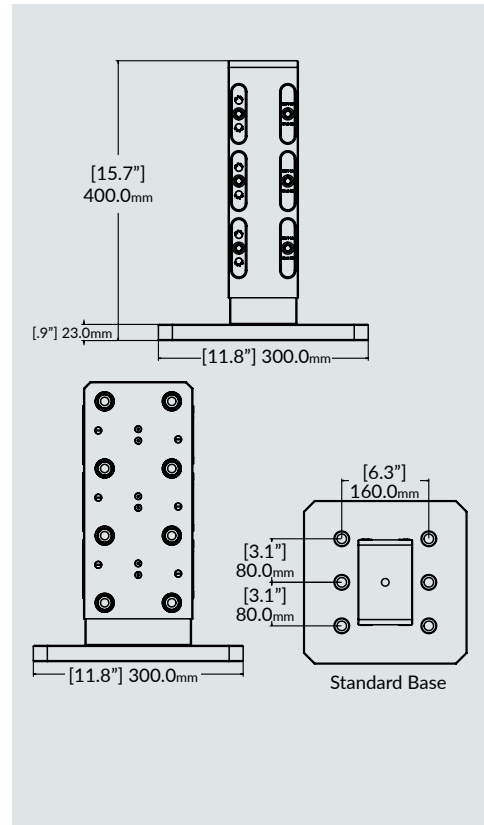

RL96A-3003 / RL96S-3003

Size: 300mm x 300mm x 400mm
Spacing: Custom
Material Construction:
 Aluminum (RL96A-3003)
 1018 Steel (RL96S-3003)

This three sided 300mm tombstone integrates the RockLock 96mm quick change system. This tombstone is perfect for mid-sized 5 Axis machines. It is also a perfect fit for 300mm horizontal machining centers offered by Kitamura and Kitagawa.

Tombstones can be ordered in aluminum or 1018 steel construction. All units feature hardened steel internals and locating features. All tombstones are built to order, and the base plate is customized to your machine table or pallet specs. 400mm and 500mm base versions are also available. Repeatability of +/- 0.0003".

Send us your table drawing for custom base.

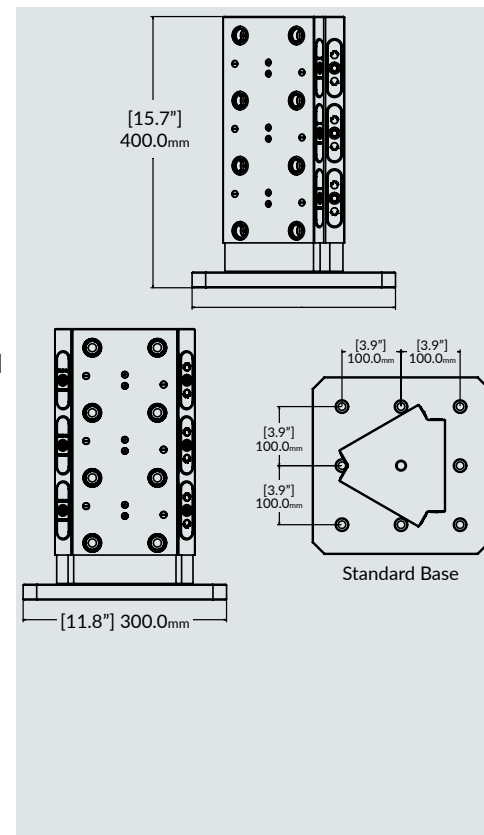

RL96A-90DEG

Size: 149.4mm x 158mm x 200mm
Spacing: RockLock PS20F or 2x M12 or 1/2" SHCS @ 100mm - 101.6mm (4")
Material Construction:
 Aluminum (RL96A-90DEG)

The 90° right angle RockLock plate is the perfect low cost solution for multi-side machining. **Machine 5 sides of a part without a 5 axis machine.** The unit features pull studs on the bottom so that it can be mounted onto any 96mm RockLock plate. It also has 2 counter bores for traditional mounting to machine T-slots at 4" or 100mm.

Simply machine your material, unlock the system, rotate the material, lock the system and continue machining.

Includes 4x PS20F.
 Repeatability of +/- 0.0003".



RL96A-356 / RL96S-356

Size: 158mm x 126mm x 75mm
Spacing: RockLock PS20F 96mm
Material Construction:
 Aluminum (RL96A-356)
 Steel (RL96S-356)

Built to give extra rise from any RockLock bases.

The profile was created as small as possible to reduce any interference.

Includes 4x PS20F.

Repeatability of +/- 0.0003".

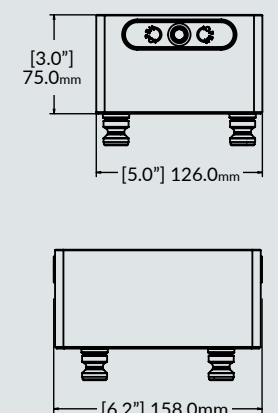
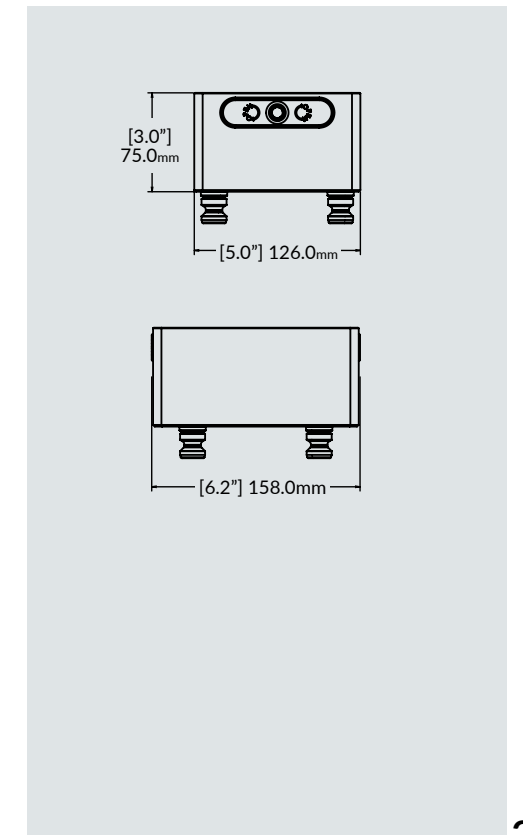
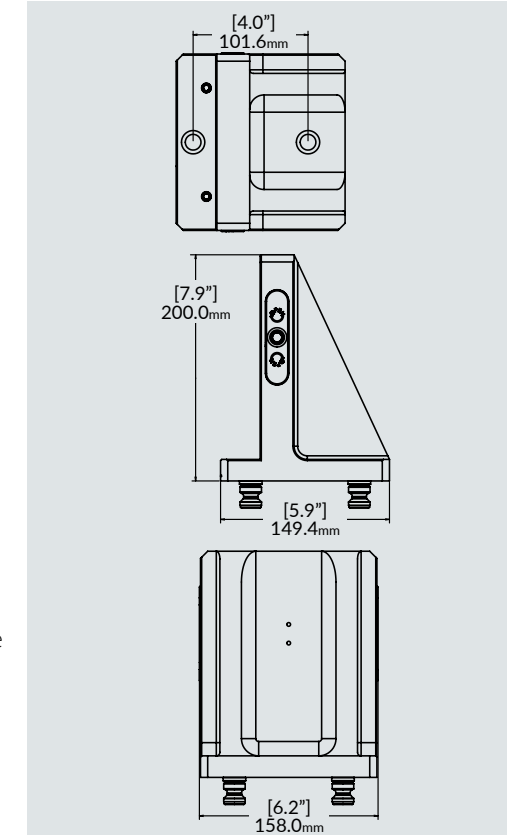
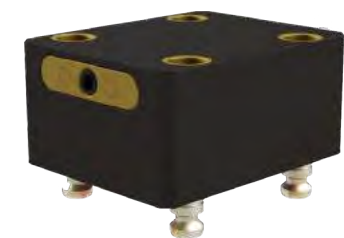

96mm RockLock

96mm RockLock

R96-V75100T4

Size: 125.7mm x 125.7mm x 266.7mm
Mounting: RockLock PS20F
Material Construction:
 Aluminum (RL96A-V75100T4)

The R96-V75100T4 is an ultra compact mini tombstone designed to work with smaller 4 and 5 Axis machines. The goal was to create a 4 sided tombstone to increase productivity while maintaining a compact footprint. The tombstone is built for the V75100X self-centering vise (see page 45). The nested bolt pattern allows for the vises to be mounted vertically or rotated horizontally. The entire tombstone will quick change onto any 96mm RockLock base plates. With a maximum of 12 vises on the tombstone, the machine can run unattended. This minimizes tool changes and frees operators up to run multiple machines. Includes 4x PS20F. Repeatability of +/- 0.0003".

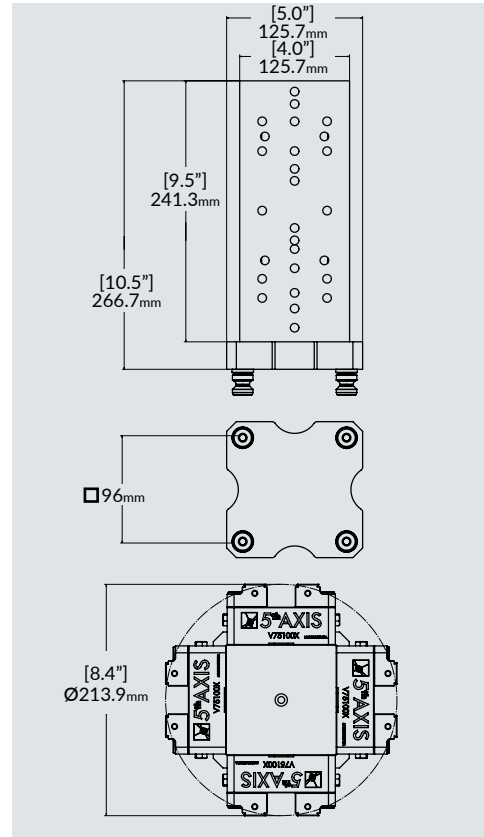

*Vises sold separately

R96-V75XT4

Size: 125.7mm x 125.7mm x 266.7mm
Mounting: RockLock PS20F
Material Construction:
 Aluminum (RL96A-V75XT4)

The R96-V75XT4 is a mini tombstone is designed to work with smaller 4 and 5 Axis machines. The goal was to create a 4 sided tombstone to increase productivity while maintaining a compact footprint. This tombstone can accommodate the following self-centering vises: V75100X and V75150X (see page 45). It will also fit the DV75150X double station vise (see page 39). The entire tombstone will quick change on any 96mm RockLock base plates. With a maximum of 8 vises on the tombstone, the machine can run unattended. This minimizes tool changes and frees operators up to run multiple machines. Includes 4x PS20F.

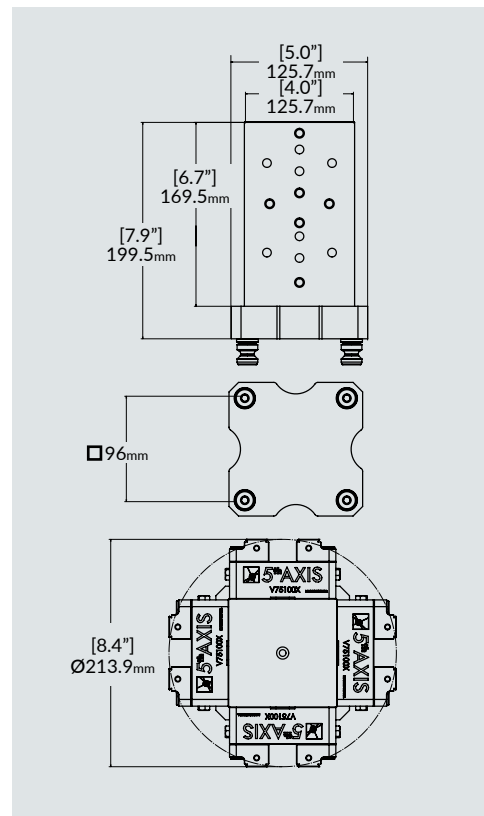

*Vises sold separately

R96-D115T41

Size: 4.95" x 4.95" x 4.2"
Spacing: RockLock PS20F

Built for small or medium rotaries. Able to utilize 4x D115 in order to maximize part density. This tombstone utilizes D115 dovetail fixtures allowing minimal interference. 4x PS20F Pull studs are included.



*Fixtures sold separately

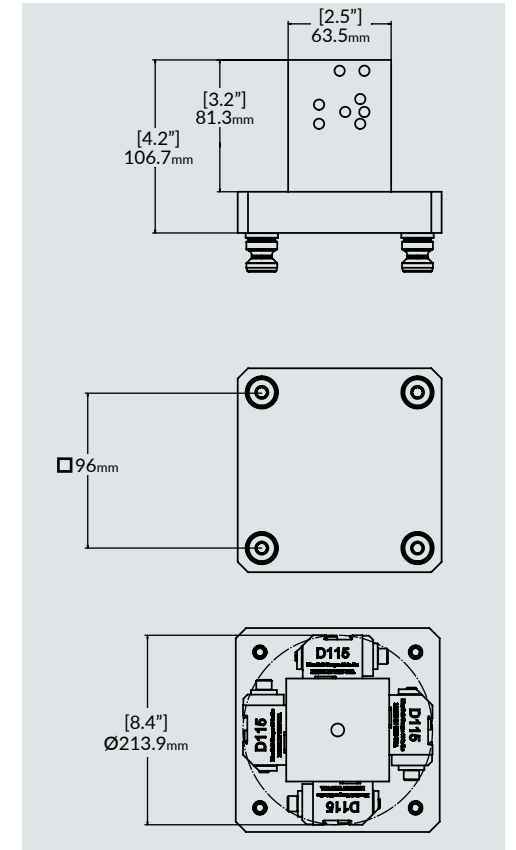

3 Sided Vise Pyramids with 3x RL96A-56

PY30RL96-56
 30° angle. For use machines with 120° or more tilt.

PY20RL96-56
 20° angle. For use with 110° or more tilt.

Pyramids are compatible with 96mm RockLock top tooling. Top tooling can be mounted in vertical or horizontal orientation. Machine make and model required when ordering to ensure correct fitment. 3x RL96A-56 are included.



96mm RockLock



PS20F

PULL STUD

Size: 96mm Pull Studs

Material Construction: S7 Tool Steel

The PS20F is required to use any 5th Axis 96mm base. The 96mm spacing allows for compatibility with other systems.

*Please note that pull studs must stay with the corresponding company's base plate. If you are using a 5th Axis 96mm RockLock base plate you will need 5th Axis pull studs (PS20F). The spacing and thread allows for the top tooling to be interchangeable between the different systems.



PS20F-PY

SINGLE PULL STUD WITH POKA-YOKE INSERT

Size: 96mm Pull Studs

Material Construction: S7 Tool Steel

Poka-yoke is a Japanese term that means "mistake-proofing". The PS20F-PY is a single modified pull stud with aluminum ring. The ring is placed inside one of the locating holes in the RockLock base, allowing for only the single poka-yoke pull stud to fit inside the locating hole with the corresponding ring. This will prevent operators from changing the orientation and misloading a part.



PS20F-4PY

PULL STUDS WITH POKA-YOKE INSERT

Size: 96mm Pull Studs

Material Construction: S7 Tool Steel

3x Standard PS20F Pull Studs and one Poka-Yoke (PS20F-PY).



R96-BLANK

Size: 96mm Pull Studs

Material Construction: 6061 Aluminum

Blank 6061 aluminum block with 4x PS20F pull studs included. Quickly build your own fixture or subplate with the R96-Blank.



RL96-MP

Size: 96mm Pull Studs

Material Construction: Steel

Mount the RockLock base onto the machine, drop in the master pallet, dial in your setup, and torque your mounting bolts once you have reached the desired location. This is the fastest, most accurate way to set up the RockLock system. See page 33 for more info.

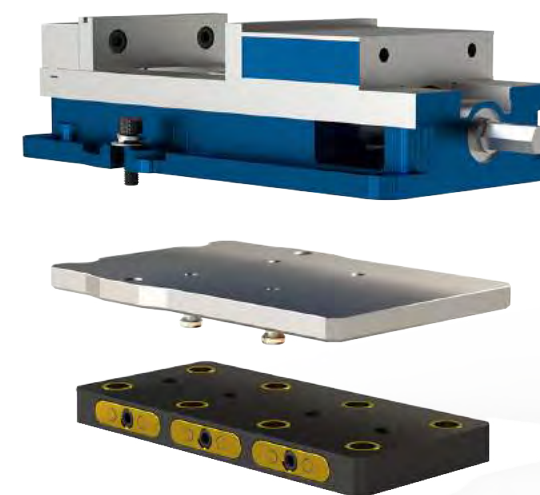

RL96-KD688 / RL96-KDX6*

Size: RL96-KD688: 13" x 8.25" x .78"

RL96-KDX6: 13" x 6.92" x .78"

Material Construction:

Aluminum (RL96-KD688)

Aluminum (RL96-KDX6)

The RL96-KD688 is built to upgrade your Kurt D-series 6" vise to the RockLock quick change system. Never indicate your Kurt vise in again! Simply bolt your Kurt vise onto the adapter and you will be off and running. Part number includes adapter + 4x PS20F pull studs.

The RL96-KDX6 is built for the newer style DX6 crossover vise. Upgrade your new Kurt DX6 to RockLock quick change system from 5th Axis. Part number includes adapter + 4x PS20F pull studs.

*Vise and RockLock base sold separately

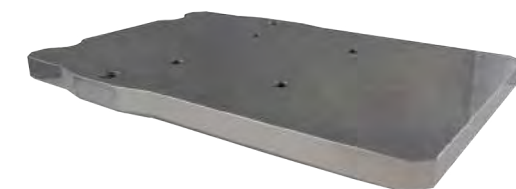

96mm RockLock



5th Axis Workholding products are designed to adapt to automated systems increasing throughput. Create profitability through efficiency.

Automation

EROWA
system solutions
SOLUTIONS

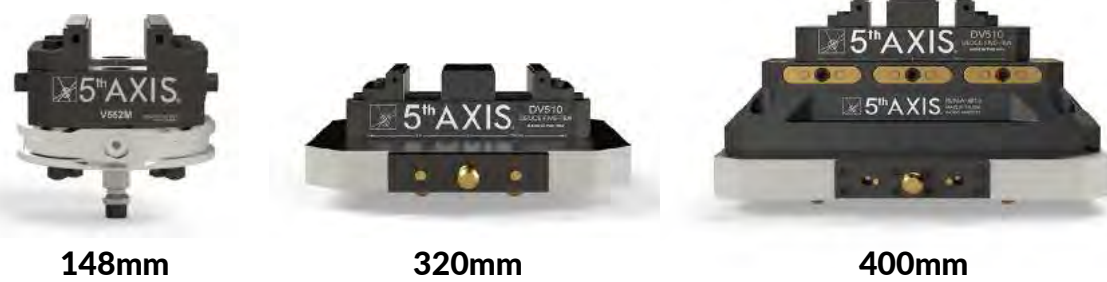

148mm

320mm

400mm

EROWA
system solutions
INTEGRATED



Integrated EROWA 52mm RockLock Available for 148mm EROWA pallets

system 3R
SOLUTIONS

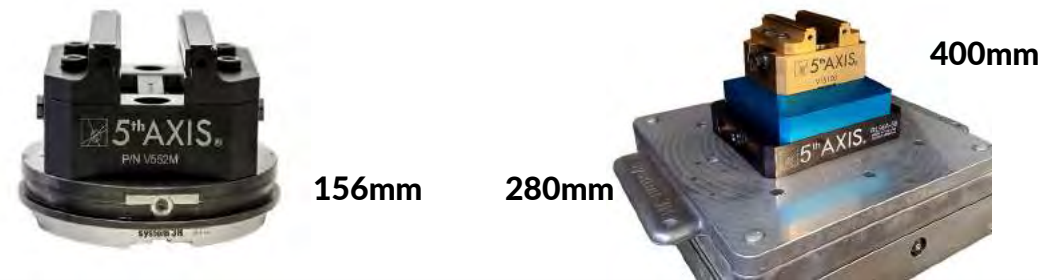

156mm

280mm

400mm

INTEGRATED SOLUTIONS FOR MATSUURA

RL96A-MAM72
RL96S-MAM72



Fits MAM72-25V/CUBLEX-25/CUBLEX-35/MAM7235V/MX-330

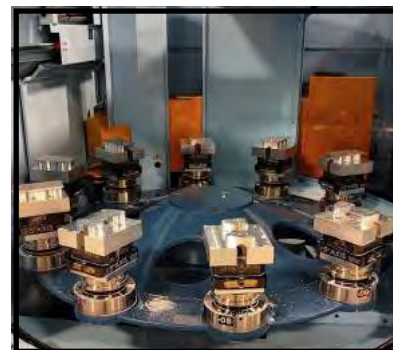

Automation Base



Available in 52mm and 96mm Pull Stud Spacing



Clamp / Unclamp Confirmation



Steel Locating Features



96mm



52mm

FAIL SAFE Air to open
Spring to Close

AUTOMATION OR MANUAL Use with robot or manual

MULTIPLE AIRPORTS Air ports located on the bottom and side of unit

Automation



Please contact us regarding the details of your automation project and we can help recommend the correct product for your application

Master Alignment Pallet



Available in 96mm and 52mm



Ensures RockLock repeatability less than .0003"



Precision milled and press fit pull studs*



One Master Pallet for all your RockLock systems

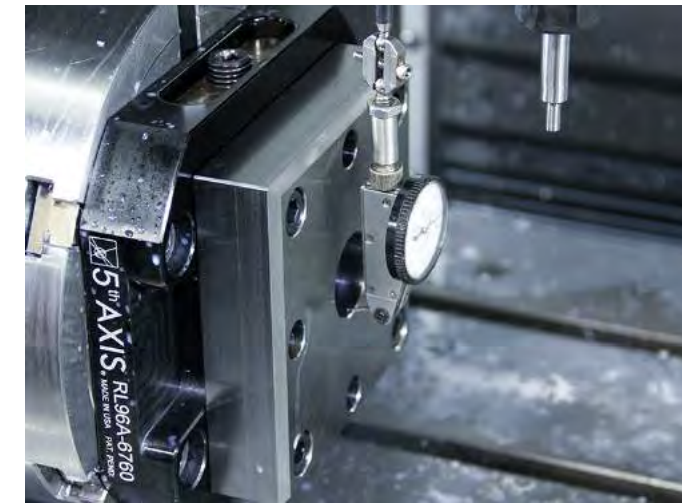

Precision center bore allows for indication of rotation.

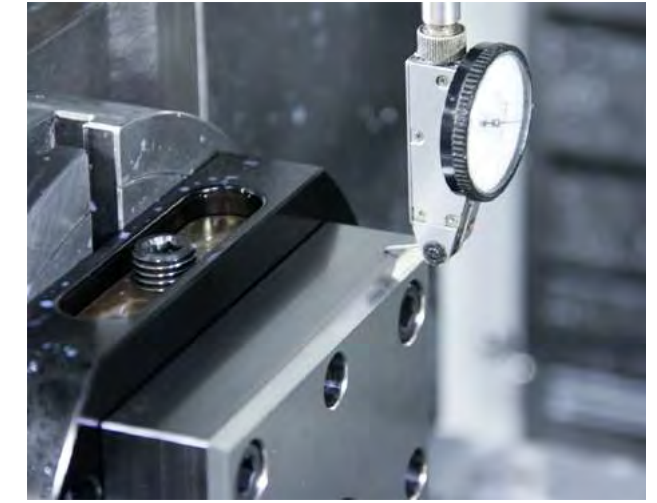

Precision milled sides allow for indication of center line.

Master Pallets

Part Number	RL52-MP	RL96-MP
Size	75mm x 75mm x 25.4mm	125.73mm x 125.73mm x 30.48mm
Mounting	RockLock PS16F Pull Studs Included	RockLock PS20F Pull Studs Included
Materials	Steel	Steel

Guarantees accuracy of the RockLock system. The Master Pallets are used to set up 52mm and 96mm RockLock systems.

Mount the RockLock base onto the machine, drop in the Master Pallet, dial in your setup, and torque your mounting bolts once you have reached the desired location.

Master Pallet will only be used on the initial setup or if you move the setup from one machine to another. This is the fastest, most accurate way to set up the RockLock system.

*Do not remove pull studs.

**Instructional video provided on our website.

***CMM report provided with purchase of Master Pallet.

Double Station Vises

BUILT FOR 3-AXIS



Convert from double station to single position fixed jaw*

Quickly change jaws / convert to soft jaws

Compact footprint maximizes table space

Not a self-centering vise

Quickly Convert From Double To Single Fixed Station*



Double Station
This configuration utilizes the center portion as the fixed position.



Independent Movement
Each jaw moves independently. This allows for stock of different sizes and ensures proper clamping.



Reversible Jaw
Jaws can quickly and easily be reversed for increased clamping range.



Removing Center Jaw
The center jaw is bolted through the base and held in position with precision bushings.



Shoulder Bolts Lock Back Jaw
The vise base has two precision bores that allow for shoulder bolts to lock the back jaw when switching to a single station.



Fixed Jaw*
In this configuration the vise operates like any traditional machine vise.
*DV56 and DV510 only

Maximize Your Table Space



Double Station



Single Station Fixed Jaw



Machinable Jaws

*Only applies to DV56 and DV510

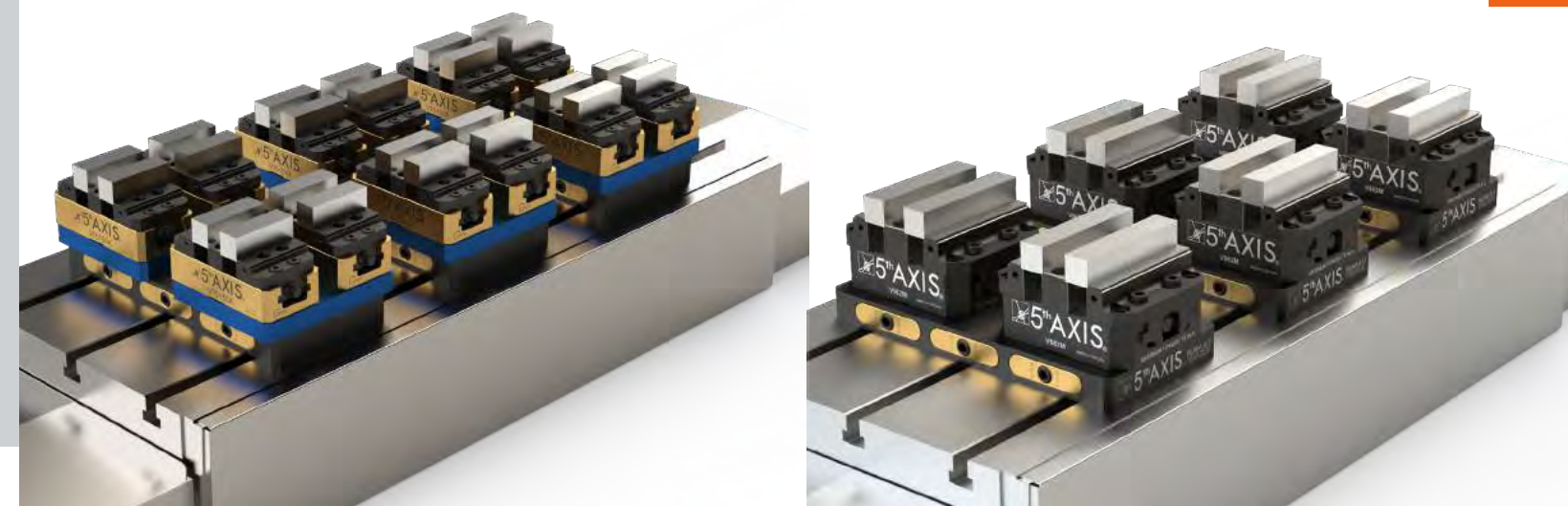





*Only applies to DV56 and DV510

Double Station

Double Station



Master Hard Jaws

Part Number	DV75150X-J1	DV56-J1	DV510-J1	DV510-J4
				
Size	75mm x 150mm x 56mm	125.7mm x 152.4mm x 72.9mm	125.7mm x 258.3mm x 73.4mm	125.7mm x 258.3mm x 73.4mm
Jaw Type	Hardened Steel 3 Piece Master Jaw Set with 2" Center Serrated / 45° Dovetail	Hardened Steel 3 Piece Master Jaw Set with 2" Center Serrated / 45° Dovetail	Hardened Steel 3 Piece Master Jaw Set with 2" Center Serrated / 45° Dovetail	Hardened Steel 3 Piece Master Jaw Set with 1" Center Serrated / 45° Dovetail
Jaw Width	75mm	125.7mm	125.7mm	125.7mm
Clamping Force	13.5 kN @ 60 Nm	20.0 kN @ 75 Nm	20.0 kN @ 75 Nm	20.0 kN @ 75 Nm
Max Torque	60 Nm	75 Nm	75 Nm	75 Nm
Forward Clamping Range	0 - 37.02mm	0 - 28.5mm	0 - 66.7mm	0 - 79.4mm
Reverse Clamping Range	17.26mm - 55.02mm	31.0mm - 64.2mm	30.9mm - 102.3mm	30.9mm - 115.0mm
Single Station Forward Clamping Range	N/A	0 - 75.9mm	0 - 177.5mm	0 - 177.5mm
Single Station Reverse Clamping Range	N/A	56.8mm - 147.3mm	56.8mm - 248.7mm	56.8mm - 248.7mm

Aluminum Jaws

Part Number	DV75150X-J2	DV56-J2	DV510-J2
			
Size	75mm x 150mm x 64.1mm	125.7mm x 152.4mm x 89mm	125.7mm x 258.3mm x 88.5mm
Jaw Type	6061 Aluminum Machinable Jaw Set	6061 Aluminum Machinable Jaw Set	6061 Aluminum Machinable Jaw Set
Jaw Width	75mm	125.7mm	125.7mm
Clamping Force	13.5 kN @ 60 Nm	20.0 kN @ 75 Nm	20.0 kN @ 75 Nm
Max Torque	60 Nm	75 Nm	75 Nm

Steel Jaws

Part Number	DV75150X-J3	DV56-J3	DV510-J3
			
Size	75mm x 150mm x 64.1mm	125.7mm x 152.4mm x 89mm	125.7mm x 258.3mm x 88.5mm
Jaw Type	1018 Steel Machinable Jaw Set	1018 Steel Machinable Jaw Set	1018 Steel Machinable Jaw Set
Jaw Width	75mm	125.7mm	125.7mm
Clamping Force	13.5 kN @ 60 Nm	20.0 kN @ 75 Nm	20.0 kN @ 75 Nm
Max Torque	60 Nm	75 Nm	75 Nm

Double Station

Double Station

DV75150X-J1 Master Hard Jaws



Size: 75mm x 150mm x 56.1mm
Jaw Set Material:
 Hardened Steel 3 Piece Master Jaw Set with Serrated / 45° Dovetail
Jaw Width: 75mm
Clamping Force: 13.5 kN @ 60 Nm
Max Torque: 60 Nm
Forward Clamping Range: 0-37.02mm
Reverse Clamping Range: 17.23 - 55.02mm

Double station vise with serrated and dovetail master jaws. Perfect for making parts that are less than 55mm x 75mm.

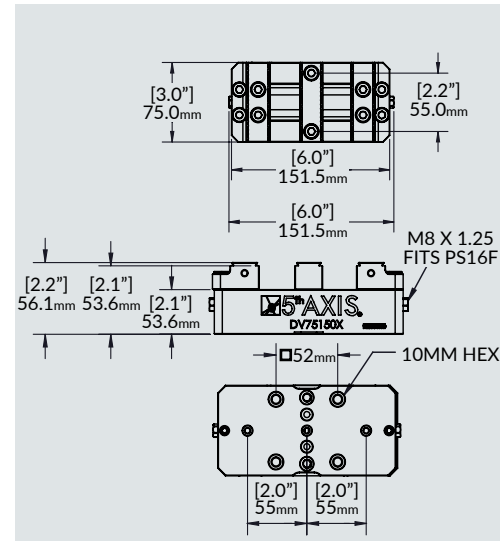

DV75150X-J2 Aluminum Jaws

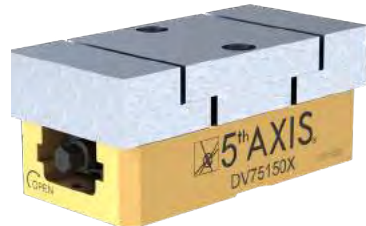

Size: 75mm x 150mm x 56.1mm
Jaw Set Material:
 6061 Aluminum Machinable Jaw Set
Jaw Width: 75mm
Clamping Force: 13.5 kN @ 60 Nm
Max Torque: 60 Nm

Double station vise with 6061 aluminum machinable jaws. Perfect for secondary operation work.

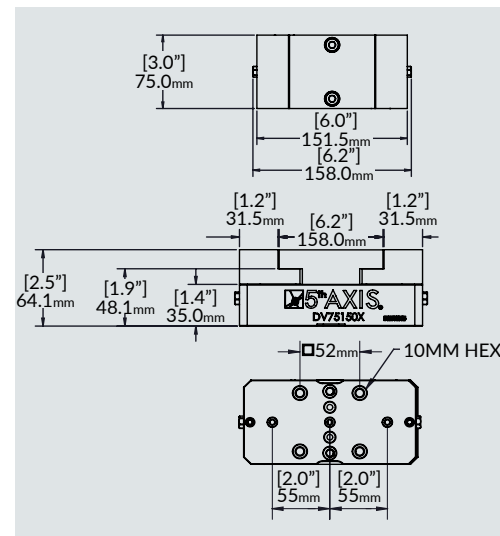

DV75150X-J3 Steel Jaws



Size: 75mm x 150mm x 56.1mm
Jaw Set Material:
 1018 Steel Machinable Jaw Set
Jaw Width: 75mm
Clamping Force: 13.5 kN @ 60 Nm
Max Torque: 60 Nm

Double station vise with 1018 steel machinable jaws. Perfect for secondary operation work.

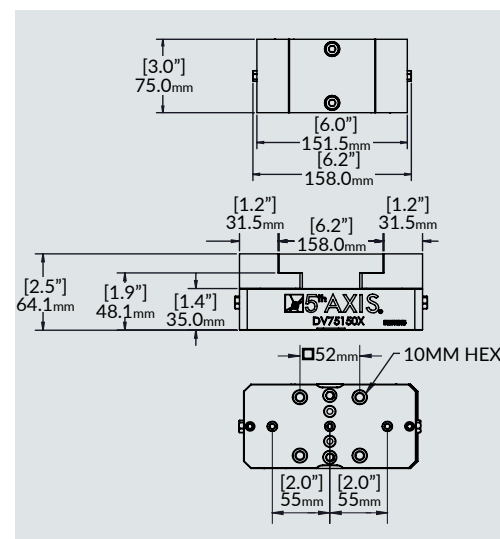

DV56-J1 Master Hard Jaws



Size: 125.7mm x 152.4mm x 72.9mm
Jaw Set Material:
 Hardened Steel 3 Piece Master Jaw Set with Serrated / 45° Dovetail
Jaw Width: 75mm
Max Torque: 75 Nm
Forward Clamping Range: 0 - 28.5mm
Reverse Clamping Range: 31mm - 64.2mm
Fixed Jaw Forward Clamping Range:
 0 - 75.9mm
Fixed Jaw Reverse Clamping Range:
 56.8 - 147.3mm

Quickly convert the DV56-J1 from a double station to a fixed single jaw vise. Perfect for parts smaller than 64.2mm x 125.7mm.

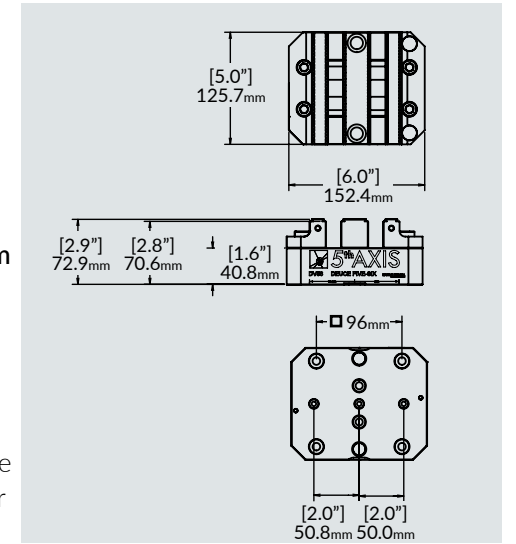

DV56-J2 Aluminum Jaws



Size: 125.7mm x 152.4mm x 89mm
Jaw Set Material:
 6061 Aluminum Machinable Jaw Set
Jaw Width: 75mm
Max Torque: 75 Nm

Double station vise with 6061 aluminum machinable jaws. Perfect for secondary operation work.

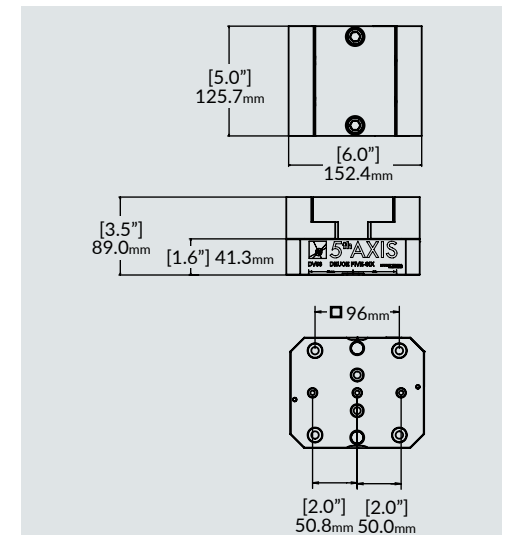

DV56-J3 Steel Jaws



Size: 125.7mm x 152.4mm x 89mm
Jaw Set Material:
 1018 Steel Machinable Jaw Set
Jaw Width: 75mm
Max Torque: 75 Nm

Double station vise with 1018 steel machinable jaws. Perfect for secondary operation work.

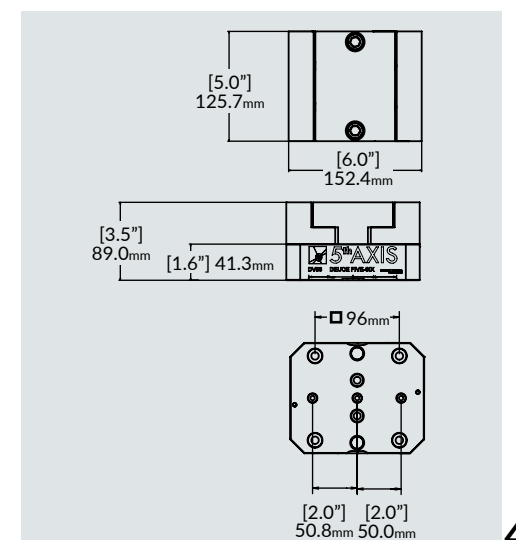

DV510-J1 Master Hard Jaws



Size: 125.7mm x 258.3mm x 73.4mm
Jaw Set Material:
 Hardened Steel 3 Piece Master Jaw Set with 2" Center and Serrated / 45° Dovetail Jaws
Jaw Width: 125.7mm
Max Torque: 75 Nm
Forward Clamping Range: 0 - 66.7mm
Reverse Clamping Range: 30.9mm - 102.3mm
Fixed Jaw Forward Clamping Range: 0 - 177.5mm
Fixed Jaw Reverse Clamping Range: 56.8mm - 248.7mm

Double station vise that converts to a fixed jaw vise. 3 piece hard jaw set with a 2" center, serrations, and 45° dovetail master jaw.

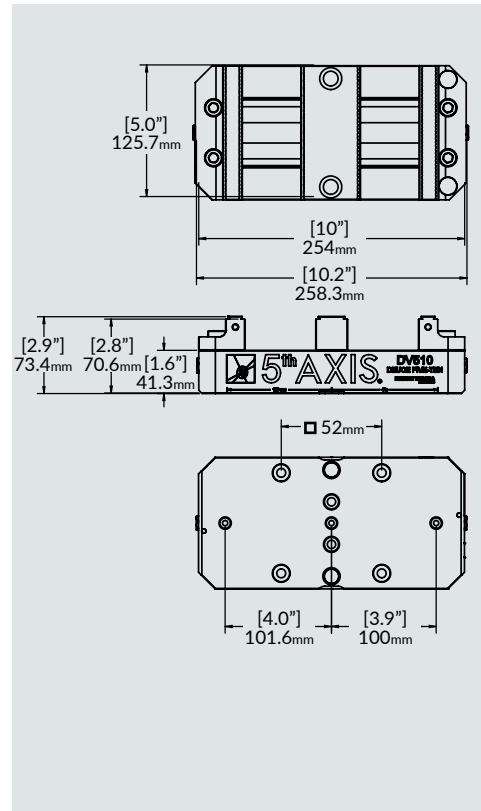

DV510-J2 Aluminum Jaws



Size: 125.7mm x 258.3mm x 88.5mm
Jaw Set Material:
 6061 Aluminum Machinable Jaw Set
Jaw Width: 125.7mm
Max Torque: 75 Nm

Double station vise with 6061 aluminum machinable jaws. Perfect for secondary operation work.

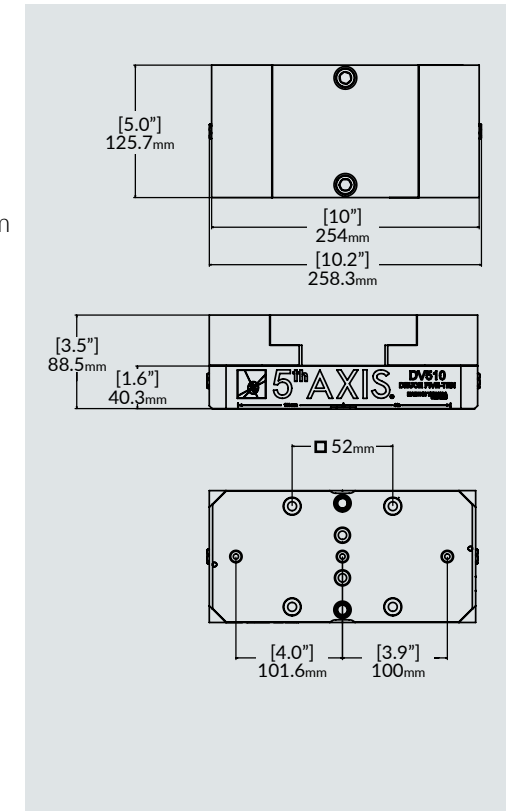

DV510-J4 Master Hard Jaws



Size: 125.7mm x 258.3mm x 73.4mm
Jaw Set Material:
 Hardened Steel 3 Piece Master Jaw Set with 1" Center and Serrated / 45° Dovetail Jaws
Jaw Width: 125.7mm
Max Torque: 75 Nm
Forward Clamping Range: 0 - 79.4mm
Reverse Clamping Range: 30.9mm - 115mm
Fixed Jaw Forward Clamping Range: 0 - 177.5mm
Fixed Jaw Reverse Clamping Range: 56.8mm - 248.7mm

Double station vise that converts to a fixed jaw vise. 3 piece hard jaw set with a 1" center, serrations, and 45° dovetail master jaw.

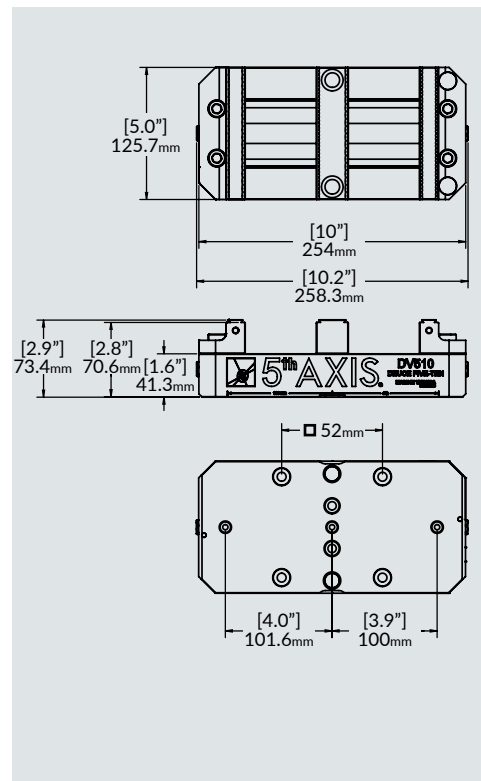

DV510-J3 Steel Jaws



Size: 125.7mm x 258.3mm x 88.5mm
Jaw Set Material:
 1018 Steel Machinable Jaw Set
Jaw Width: 125.7mm
Max Torque: 75 Nm

Double station vise with 1018 steel machinable jaws. Perfect for secondary operation work.

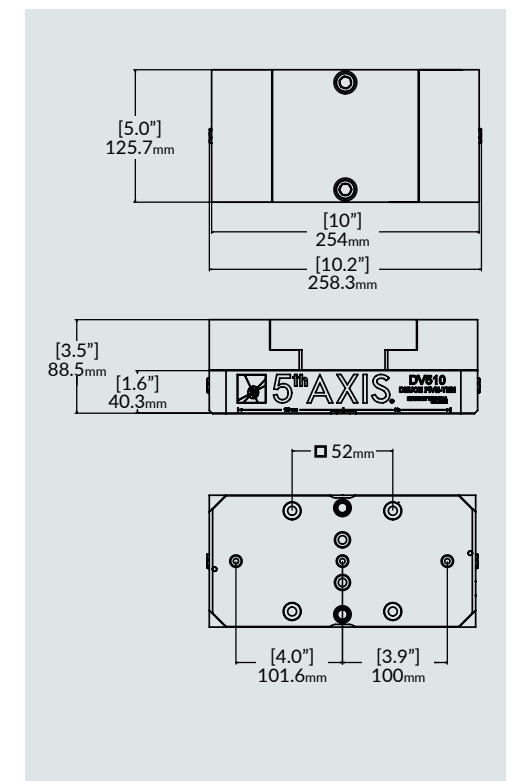

Double Station

Double Station

Self-Centering Vises



Built in 45° dovetail can be utilized for increased clamping force

Serrated gripper teeth for superior bite into soft material

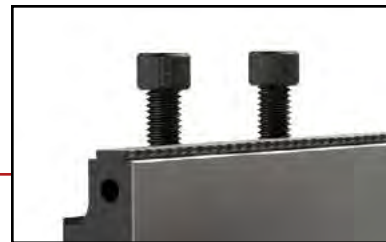
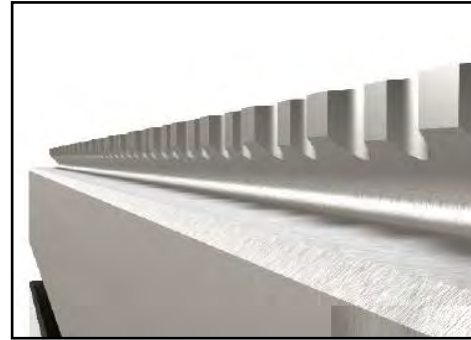

Quick change jaws without disassembling vise



Pre-drilled for pull studs

Hardened steel

+/- 0.0005" on center

Large leadscrew

Jaws are easy to remove

Easy mounting to machine

Part Number	V75100X	V75150X	V552	V552M
Size	75mm x 100mm x 56mm	75mm x 150mm x 56mm	5" x 5" x 2.9"	125.7mm x 127mm x 73.6mm
Jaw Width	75mm	75mm	4.95"	125.7mm
Clamping Force	13.5 kN @ 60 Nm	13.5 kN @ 60 Nm	4400 lbs @ 55 ft lbs	20.0 kN @ 75 Nm
Max Torque	60 Nm	60 Nm	55 ft lbs	75 Nm
Forward Clamping Range	0 - 40.3mm	0 - 92.8mm	0 - 2.60"	0 - 56.9mm
Reverse Clamping Range	38.5mm - 76.3mm	38.5mm - 128.8mm	2.69" - 5.16"	77.8mm - 128.3mm

Part Number	V562	V562M	V510M	V6105	V6105M
Size	5" x 6" x 2.9"	125.7mm x 152.4mm x 73.6mm	126mm x 152mm x 74mm	6" x 10.2" x 3.7"	150mm x 250mm x 94.1mm
Jaw Width	4.95"	125.7mm	126mm	5.9"	150mm
Clamping Force	4400 lbs @ 55 ft lbs	20.0 kN @ 75 Nm	20.0 kN @ 75 Nm	6000 lbs @ 75 ft lbs	26.7 kN @ 100 Nm
Max Torque	55 ft lbs	75 Nm	75 Nm	75 ft lbs	100 Nm
Forward Clamping Range	0 - 3.61"	0 - 82.3mm	0 - 183.9mm	0 - 6.53"	0 - 155.4mm
Reverse Clamping Range	2.89" - 6.17"	77.7mm - 153.6mm	72.6mm - 254.8mm	3.3" - 10.0"	93.6mm - 243.3mm

V75100X

Metric



Size: 75mm x 100mm x 56mm
Jaw Width: 75mm
Forward Jaws Clamping Range: 0 - 40.3mm
Reverse Jaws Clamping Range: 38.5mm - 76.3mm
Clamping Force: 13.5 kN @ 60 Nm
Torque Vise Assembly: 60 Nm

The V75100X is the most recent revision of our V75100 vise. Now equipped with 4 bolt jaw mounting to reduce jaw lift providing robust clamping and sharper teeth for a better bite.

This small compact 5 axis vise was created to be used on very small office type mills and micro pallet changers. We took the technology in the V552 and V562 and shrunk it down to create what is now the V75100X.

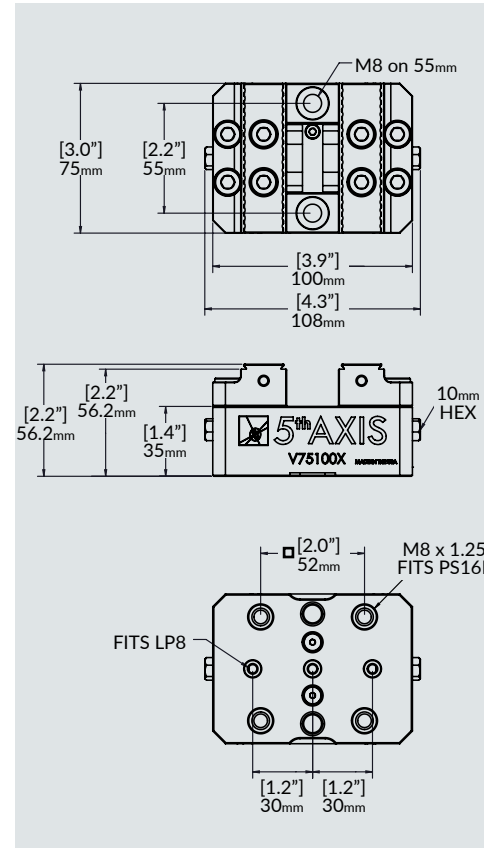

V552

Inch



Size: 5" x 5" x 2.8"
Jaw Width: 4.95"
Forward Jaws Clamping Range: 0 - 2.60"
Reverse Jaws Clamping Range: 2.69" - 5.16"
Clamping Force: 4400 lbs @ 55 ft lbs
Torque Vise Assembly: 55 ft lbs

The V552 is a 5" x 5" self-centering vise. It was created with the goal of fitting a self-centering vise on a small pallet for robotic loading cells. It has quickly become a favorite vise for shops utilizing smaller palletized systems as well as smaller rotary tables where clearance is a major concern.

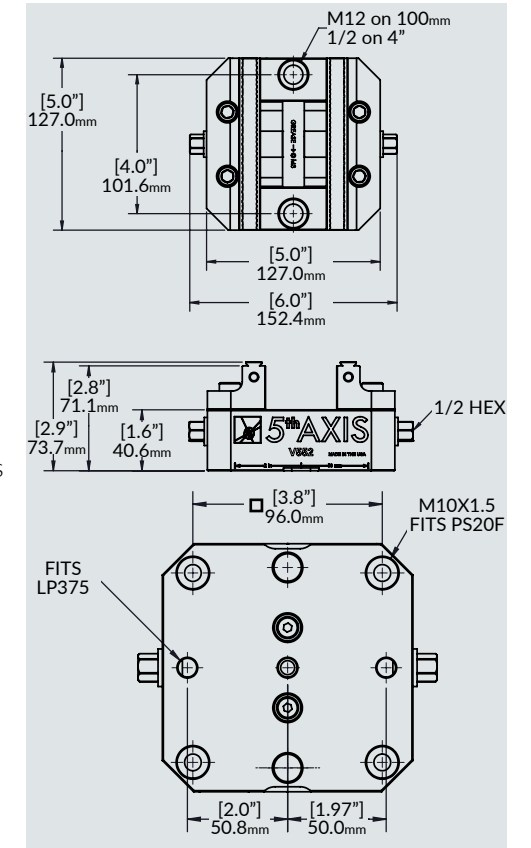

V75150X

Metric



Size: 75mm x 150mm x 56mm
Jaw Width: 75mm
Forward Jaws Clamping Range: 0 - 92.8mm
Reverse Jaws Clamping Range: 38.5mm - 128.8mm
Clamping Force: 13.5 kN @ 60 Nm
Torque Vise Assembly: 60 Nm

The V75150X was created out of customer demand for a small self-centering vise with an increased clamping range over the popular V75100X vise. The base is 50mm longer than the standard V75100X, allowing the max workpiece size to increase from 76mm to 128mm. The V75150X maintains the same 75mm jaw width for maximum tool clearance. The new 4 bolt jaw mounting design reduces jaw lift and the sharper teeth provide a superior bite in raw material.

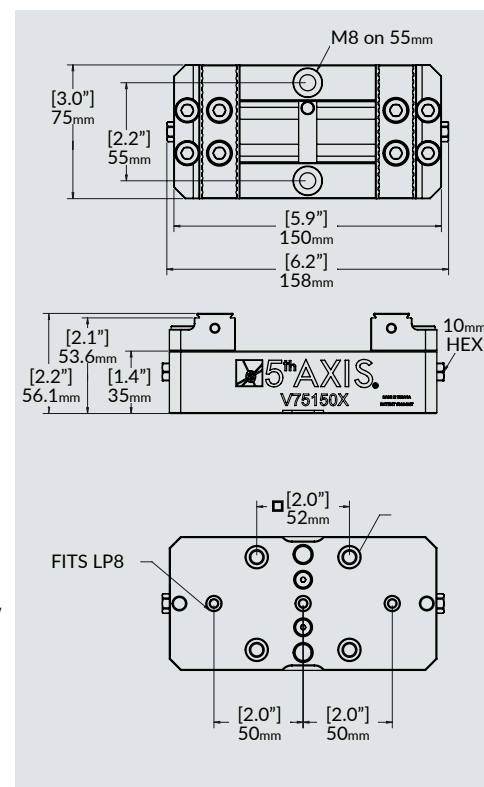

V552M

Metric



Size: 125.7mm x 127mm x 73.6mm
Jaw Width: 125.7mm
Forward Jaws Clamping Range: 0 - 56.9mm
Reverse Jaws Clamping Range: 77.8mm - 128.3mm
Clamping Force: 20.0 kN @ 75 Nm
Torque Vise Assembly: 75 Nm

The V552M is a 125mm x 125mm vise. It was created with the goal of fitting a self-centering vise on a small pallet for robotic loading cells. It has quickly become a favorite vise for shops utilizing smaller palletized systems as well as smaller rotary tables where clearance is a major concern.

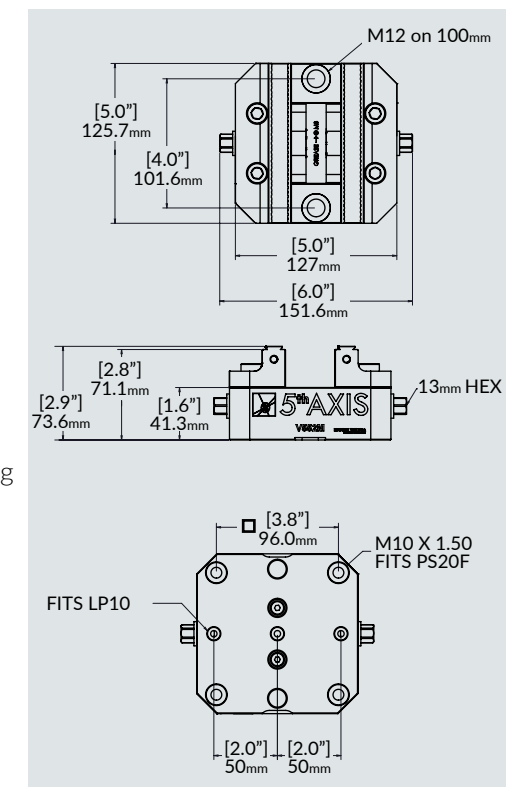

V562 Inch



Size: 5" x 6.0" x 2.9"
Material Construction:
Jaw Width: 4.95"
Forward Jaws Clamping Range:
 0 - 3.61"
Reverse Jaws Clamping Range:
 2.89" - 6.17"
Clamping Force: 4400 lbs @ 55 ft lbs
Torque Vise Assembly: 55 ft lbs

The V562 is the best selling self-centering vise in our product line. Its compact foot print and low profile design has made it the most popular choice for machine shops across the world. The V562 is built from heat treated 4100 series steel and is precision ground and hard milled to ensure accuracy and repeatability.

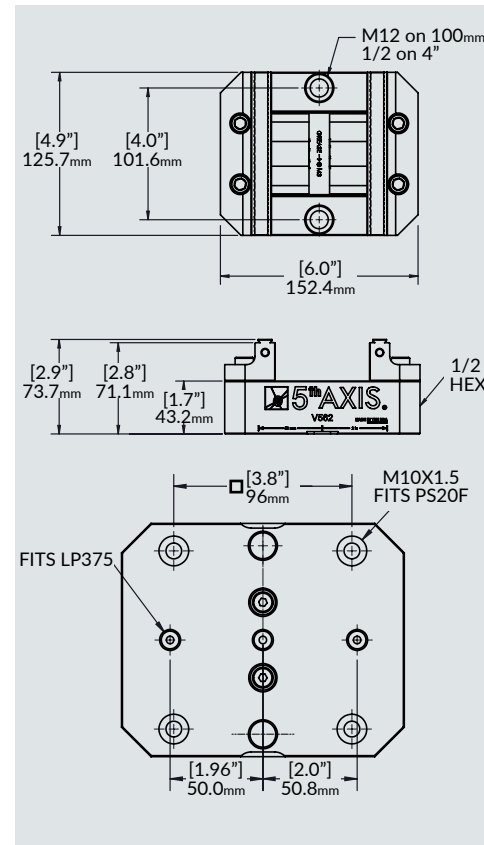

V510M Metric



Size: 126mm x 152.4mm x 73.6mm
Jaw Width: 126mm
Forward Jaws Clamping Range:
 0 - 183.9mm
Reverse Jaws Clamping Range:
 72.6mm - 254.8mm
Clamping Force: 20.0 kN @ 100 Nm
Torque Vise Assembly: 100 Nm

The V510M has all of the robust features of the V562M with the added an increased clamping range. With 254mm of clamping range, the V510M is a perfect fit for shops looking for a small footprint vise with a larger clamping range. The V510M is built from hardened and ground 4100 series steel to ensure accuracy and repeatability.

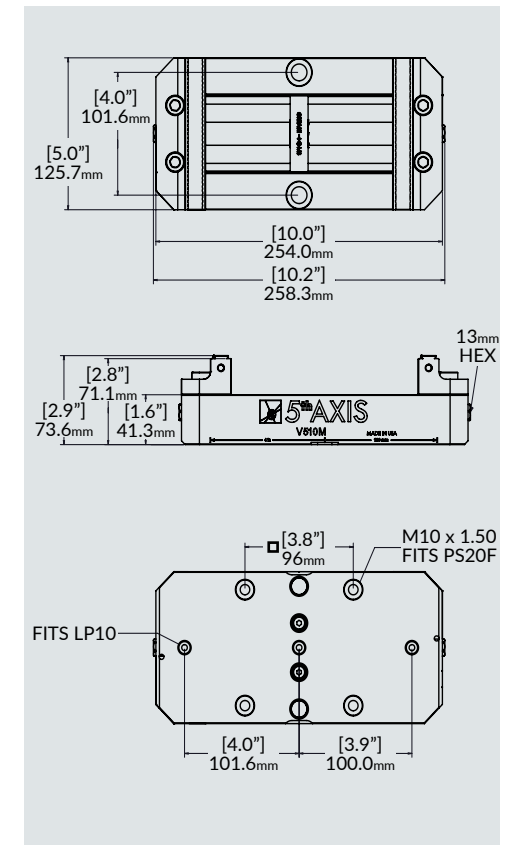

V562M Metric



Size: 125.7mm x 152.4mm x 73.6mm
Jaw Width: 125.7mm
Forward Jaws Clamping Range:
 0 - 82.3mm
Reverse Jaws Clamping Range:
 77.7mm - 153.6mm
Clamping Force: 20.0 kN @ 75 Nm
Torque Vise Assembly: 75 Nm

The V562M is the best selling self-centering vise in our product line. Its compact foot print and low-profile design has made it the most popular choice for machine shops across the world. The V562M is built from heat treated 4100 series steel and is precision ground and hard milled to ensure accuracy and repeatability.

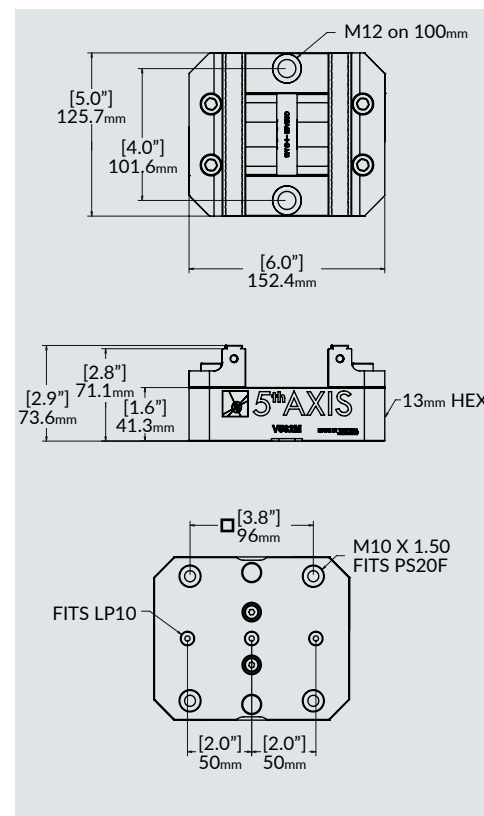

V6105 Inch



Size: 6" x 10.0" x 3.7"
Jaw Width: 5.9"
Forward Jaws Clamping Range:
 0 - 6.53"
Reverse Jaws Clamping Range:
 3.3" - 10.0"
Clamping Force: 6000 lbs @ 75 ft lbs
Torque Vise Assembly: 75 ft lbs

The V6105 is the largest 5 axis self-centering vise in our product line. Its compact foot print and low-profile design has made it a popular choice for machine shops across the world. The V6105 is built from heat treated 4100 series steel and is precision ground and hard milled to ensure accuracy and repeatability.

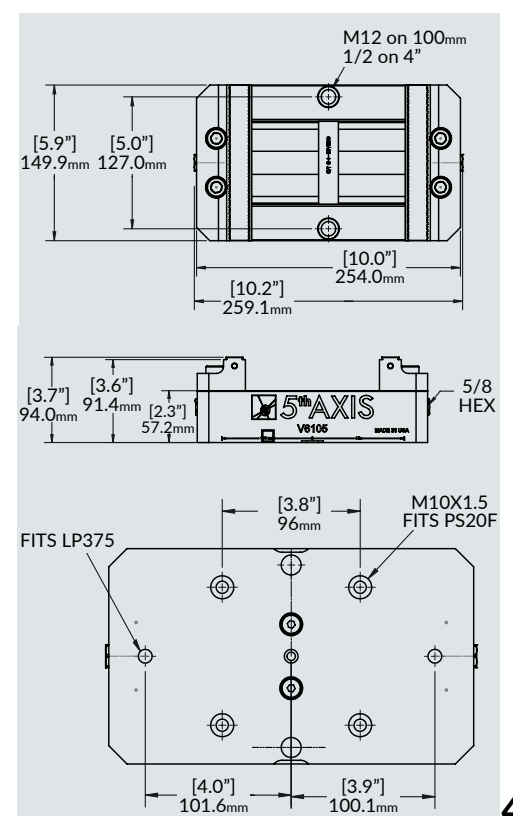

V6105M Metric



Size: 150mm x 250mm x 94.1mm
Jaw Width: 150mm
Forward Jaws Clamping Range:
 0 - 155.4mm
Reverse Jaws Clamping Range:
 93.6mm - 243.3mm
Clamping Force: 26.7 kN @ 100 Nm
Torque Vise Assembly: 100 Nm



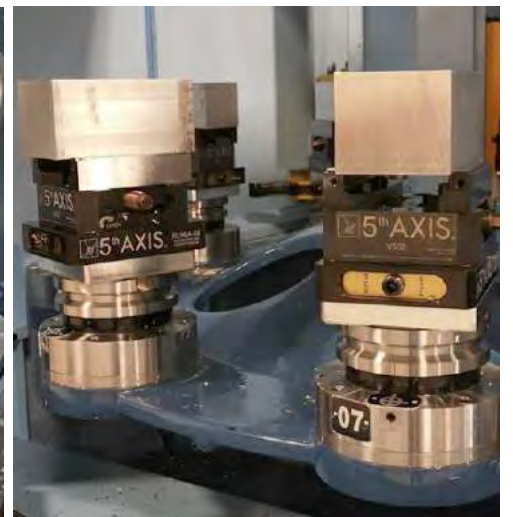
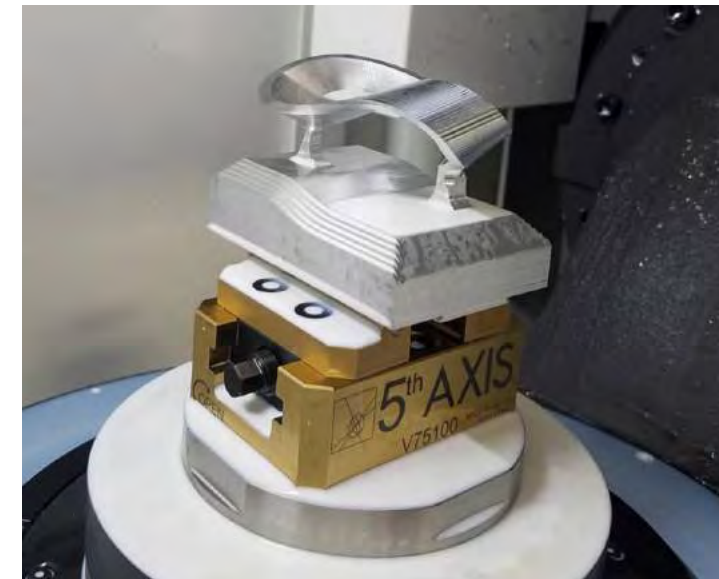
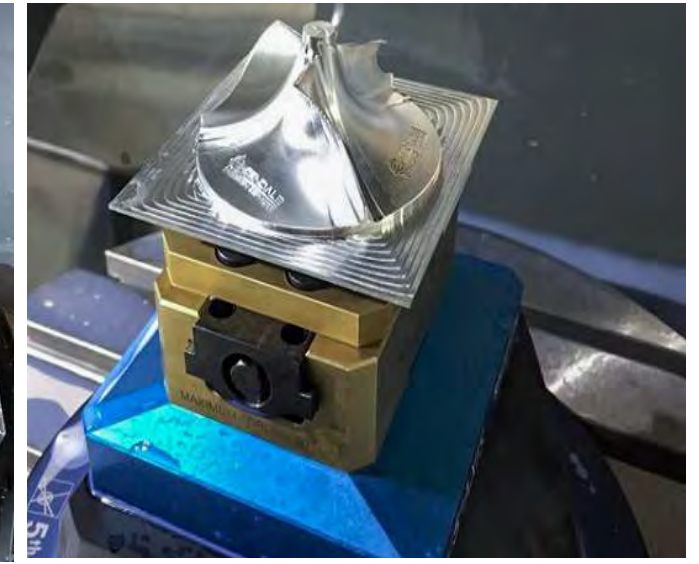
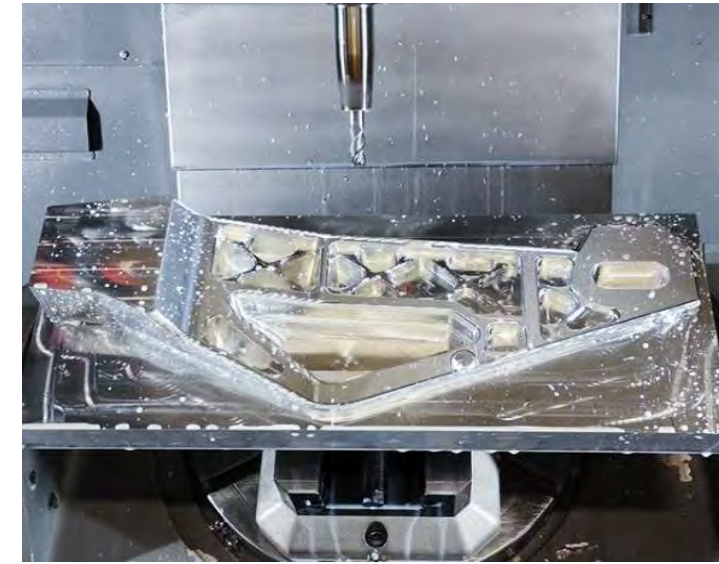
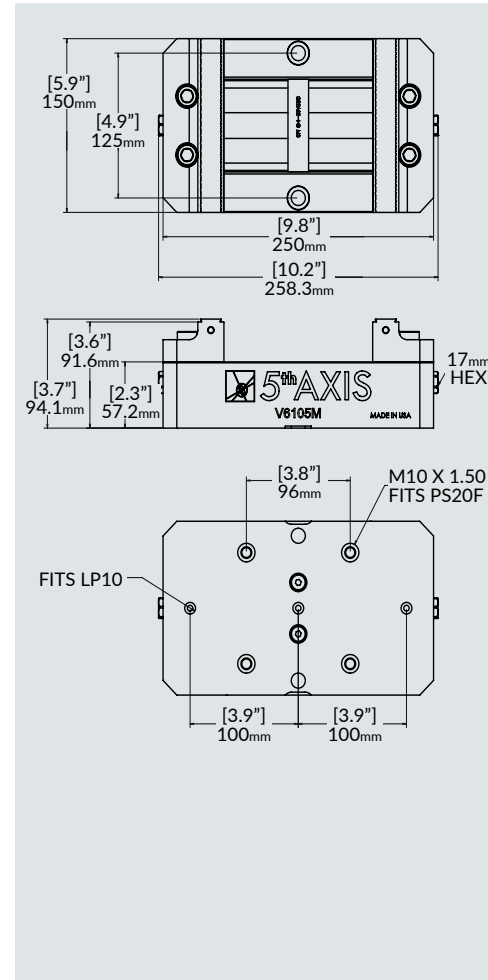

The V6105M is the largest 5 axis self-centering vise in our product line. Its compact foot print and low profile design has made it a popular choice for machine shops across the world. The V6105M is built from heat treated 4100 series steel and is precision ground and hard milled to ensure accuracy and repeatability.

The "Master Jaws" on the V6105M self-centering vise are manufactured from hardened 4100 series steel. The jaws feature: 45 degree dovetail, 2.50mm step, and serrated gripper teeth for clamping aluminum and soft steel.

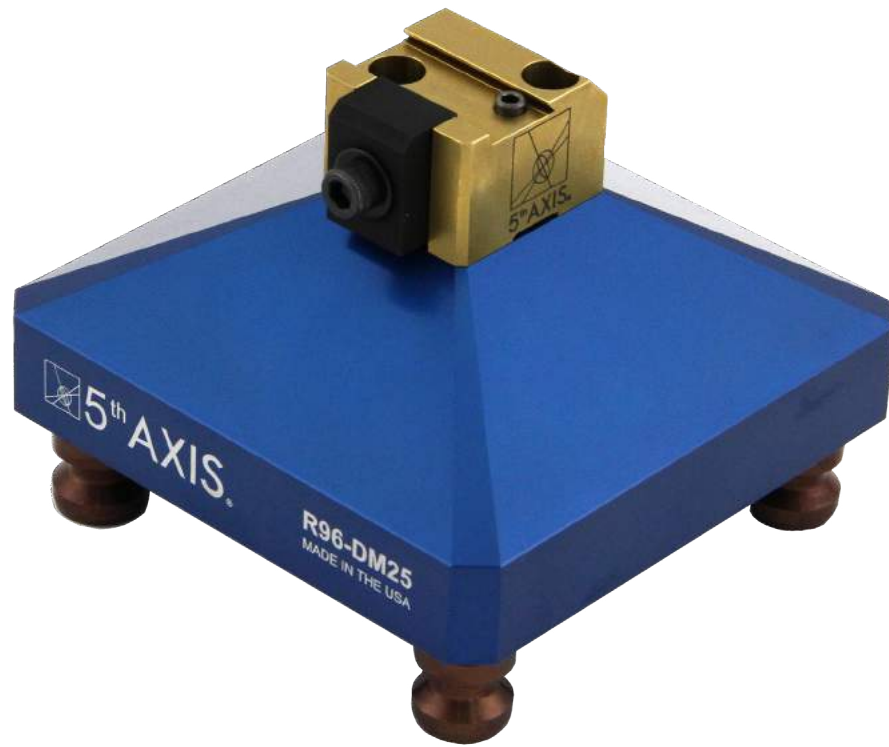



Dovetail Fixtures





-  45° dovetail for increased clamping force
-  Locating pins for precise repeatability
-  Low profile design
-  Hardened steel clamp and body



Small footprint	Steel construction
Removable locating pins	Single actuation
Unsurpassed clamping force	Easy mounting to machine

Metric Dovetail Fixtures

Part Number	DM12	DM25	DM50
			
Size	21mm x 32mm x 19mm	37mm x 41mm x 27mm	50mm x 50mm x 38mm
Stock Size	12mm - 25mm	25mm - 75mm	50mm and Above
Dovetail Depth	2.54mm	2.54mm	5.08mm

Inch Dovetail Fixtures

Part Number	D05125	D115	D115P
			
Size	1.23" x 1.31" x .75"	1.5" x 2.3" x 1.5"	1.6" x 2.5" x 1.5"
Stock Size	0.5" - 1"	1" - 3"	Picatinny
Dovetail Depth	.100"	.100"	Picatinny

Part Number	D22	D362
		
Size	2" x 2" x 1.5"	6" x 3" x 1.3"
Stock Size	2" and Above	3" and Above
Dovetail Depth	.200"	.200"

CAD models available for download at fifthaxis.com/downloads

DM12 Metric



Size: 21mm x 32mm x 19mm
Material: 4100 Series Steel
Stock Size: 12mm - 25mm
Dovetail Depth Required: 2.54mm

The DM12 is the smallest dovetail fixture in the 5th Axis workholding line. The DM12 features a wedge style clamp for superior gripping force and a low-profile design that optimizes tool clearance. This micro dovetail fixture is the perfect choice for multi-axis work on smaller parts.

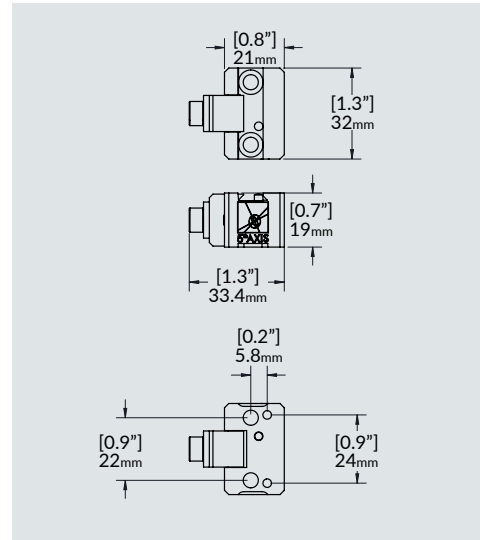

D05125 Inch



Size: 1.23" x 1.31" x .75"
Material: 4100 Series Steel
Stock Size: 0.5" - 1"
Dovetail Depth Required: 0.80"

The D05125 is the smallest dovetail fixture in the 5th Axis workholding line. It is a simple and robust dovetail fixture built for stock under 1". The D05125 features a wedge style clamp for superior gripping force and a low profile design that optimizes tool clearance. This micro dovetail fixture is the perfect choice for multi-axis work on smaller parts.

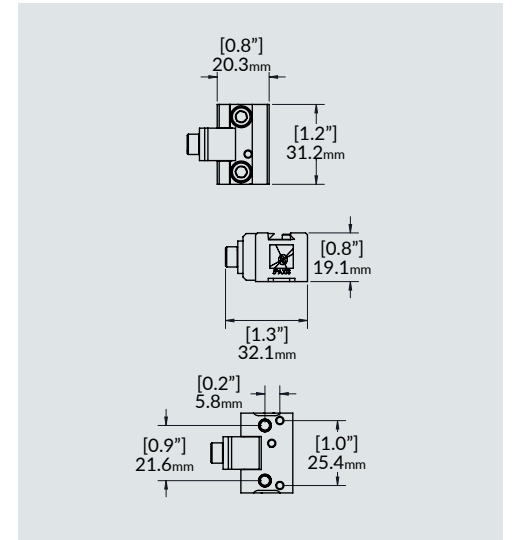

DM25 Metric



Size: 37mm x 41mm x 27mm
Material: 4100 Series Steel
Stock Size: 25mm - 75mm
Dovetail Depth Required: 2.54mm

The DM25 is the most versatile dovetail fixture in the 5th Axis workholding line. It is a simple and robust dovetail fixture built for stock under 75mm. The DM25 features a robust clamp for superior gripping force and a low-profile design that optimizes tool clearance. This dovetail fixture is the perfect choice for multi-axis work on small to medium sized parts.

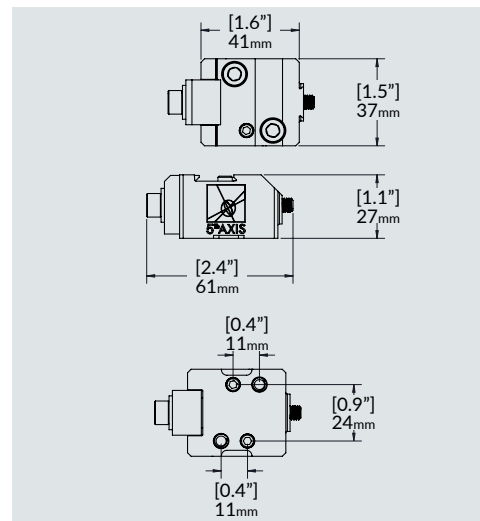

D115 Inch



Size: 1.5" x 2.3" x 1.5"
Material: 4100 Series Steel
Stock Size: 1" - 3"
Dovetail Depth Required: 0.80"

The D115 is the most versatile dovetail fixture in the 5th Axis workholding line. It is a simple and robust dovetail fixture built for stock under 3". The D115 features a robust clamp for superior gripping force and a low profile design that optimizes tool clearance. This dovetail fixture is the perfect choice for multi axis work on small to medium sized parts.

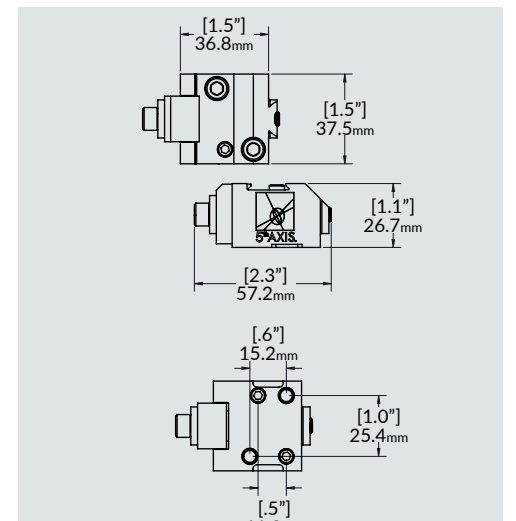

DM50 Metric



Size: 50mm x 50mm x 38mm
Material: 4100 Series Steel
Stock Size: 50mm+
Dovetail Depth Required: 5.08mm

The DM50 is a 50mm x 38mm dovetail fixture in the 5th Axis workholding line. The DM50 is a simple and robust dovetail fixture built for stock 50mm and above, features a wedge style clamp for superior gripping force, and a low-profile design that optimizes tool clearance.

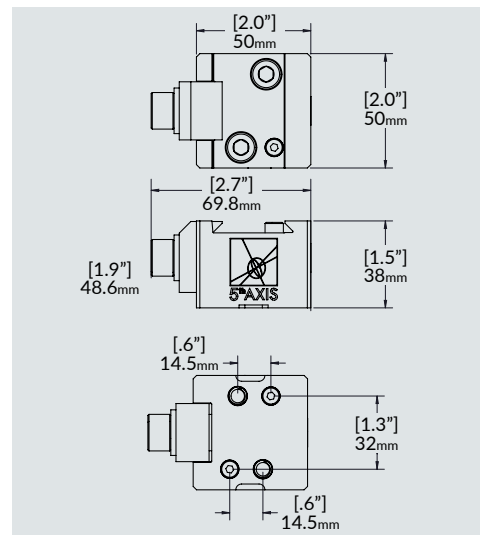

D115P Inch



Size: 1.6" x 2.5" x 1.5"
Material: 4100 Series Steel
Min Stock Size: 1.0"
Dovetail Depth Required: 0.80"

The D115P is built to hold picatinny rails. The D115P features a robust clamp for superior gripping force and a low profile design that optimizes tool clearance.

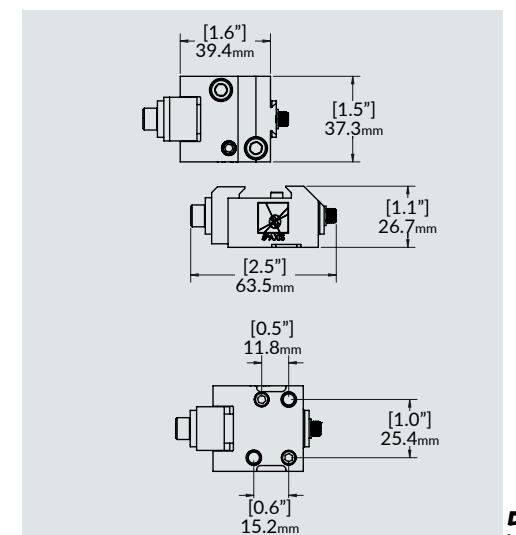

D22 Inch



Size: 2" x 2" x 1.5"
Material: 4100 Series Steel
Stock Size: 2"+
Dovetail Depth Required: 0.150"

The D22 is a 2" x 2" dovetail fixture built for stock 2" and above. The D22 features a wedge style clamp for superior gripping force and a low profile design that optimizes tool clearance.

The D22 was designed with a modular footprint in mind. This fixture features removable locating pins top and bottom which allow for flexible mounting options. The D22 can be used as a stand alone unit, on a gang plate, or mounted on a pyramid with multiple other units.

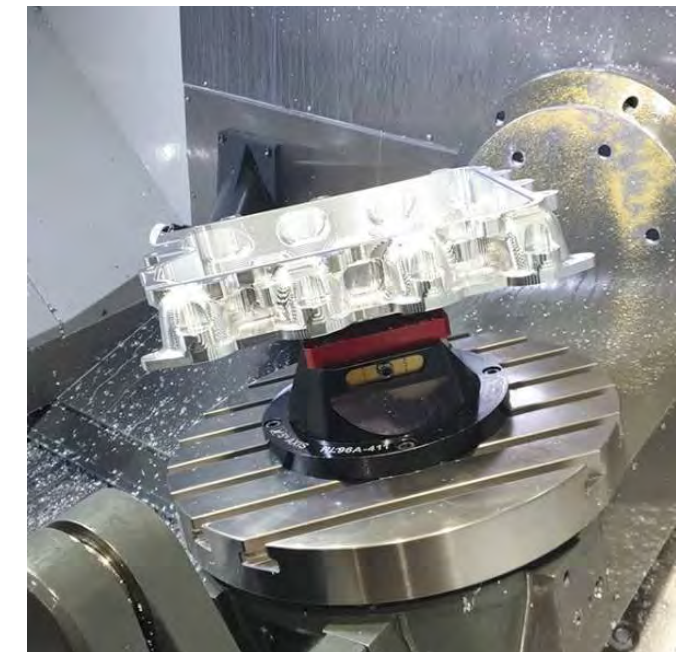
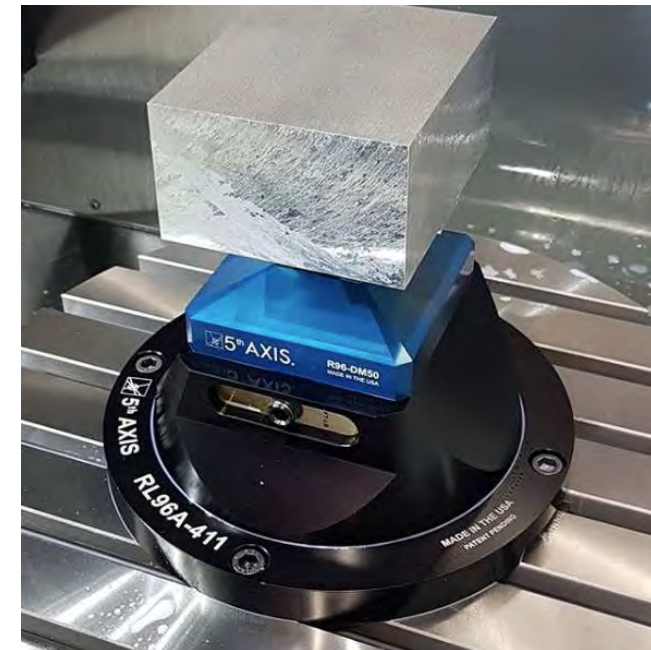
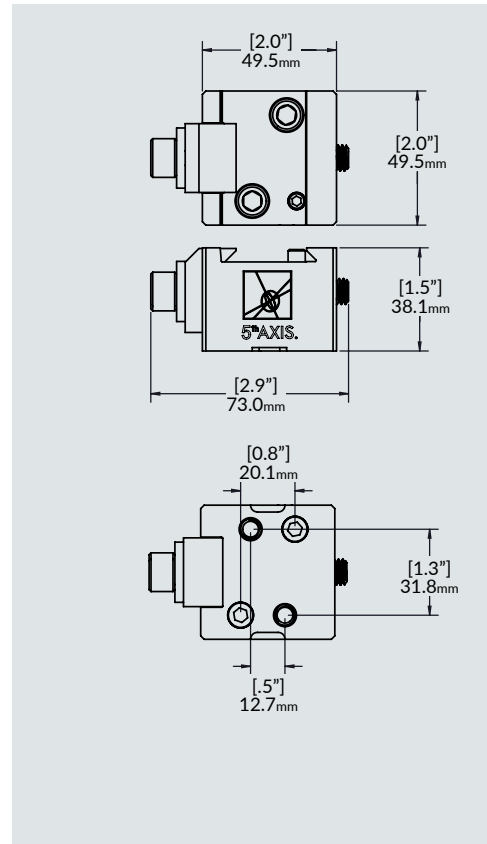

D362 Inch



Size: 6" x 3" x 1.3"
Material: 4100 Series Steel
Stock Size: 3"+
Dovetail Depth Required: 0.150"

The D362 is the largest dovetail fixture in the 5th Axis workholding line. It is built for stock 3" and above. The D362 features two wedge style clamps for superior gripping force and a low profile design that optimizes tool clearance. This dovetail fixture is the perfect choice for multi axis work on larger workpieces.

The D362 was designed with a modular footprint in mind. This fixture features removable locating pins top and bottom which allow for flexible mounting options. The D362 can be used as a stand alone unit, on a gang plate, or mounted pyramid with multiple other units.

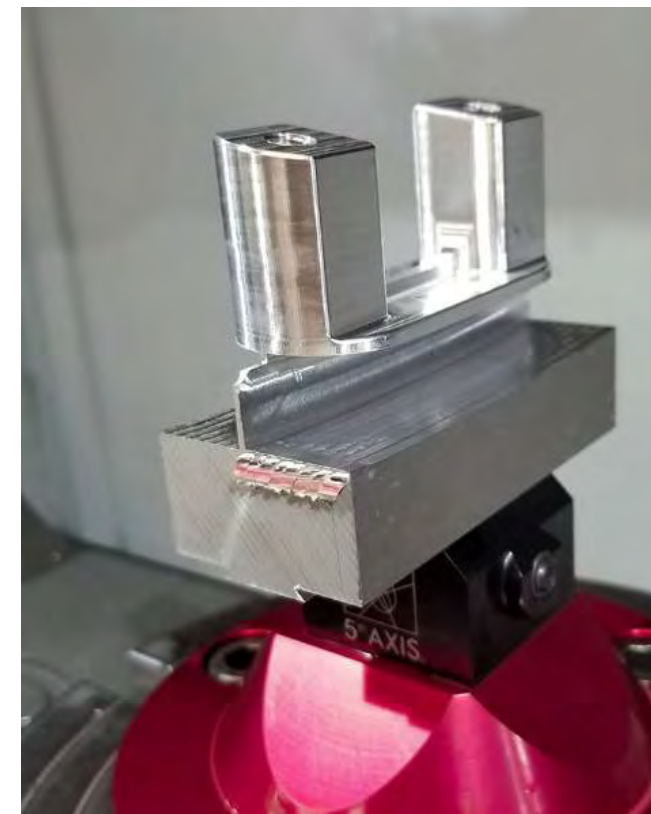
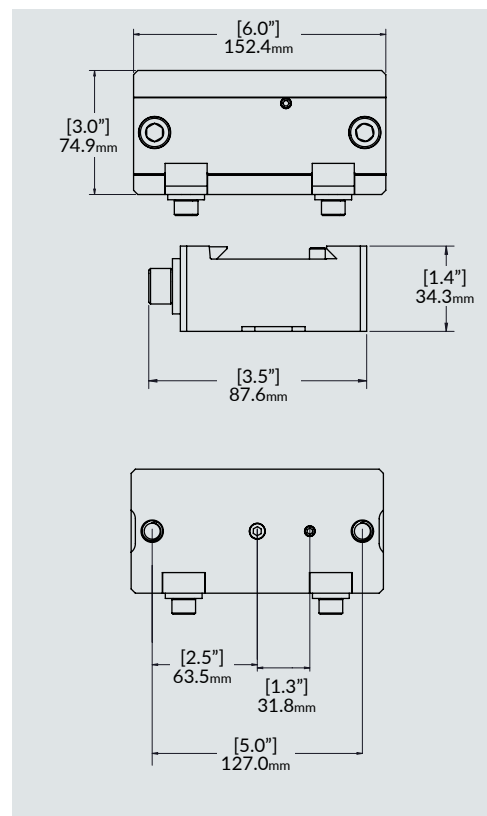

R52-P12DM12

Metric

Spacing: 125.73mm x 125.73mm x 133.5mm
Material Construction: 6061 Aluminum

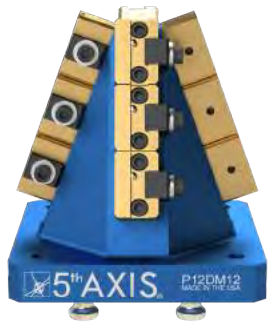

Built for our 52mm RockLock Quick Change System, the R52-P12DM12 provides maximum amount of flexibility. This 4 sided pyramid utilizes twelve DM12 dovetail fixtures for stock under 25mm. The orientation of the fixtures on the pyramid ensures optimal tool clearance for multiple parts. Machine up to 12 parts on this compact unit. The modular design allows for fixtures to be added or removed depending on the length of the workpiece.

R96-P12DM12

Metric

Spacing: 125.73mm x 125.73mm x 133.5mm
Material Construction: 6061 Aluminum

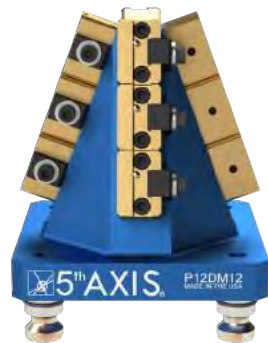

Built for our 96mm RockLock Quick Change System, the R96-P12DM12 provides maximum amount of flexibility. This 4 sided pyramid utilizes twelve DM12 dovetail fixtures for stock under 25mm. The orientation of the fixtures on the pyramid ensures optimal tool clearance for multiple parts. Machine up to 12 parts on this compact unit. The modular design allows for fixtures to be added or removed depending on the length of the workpiece.

R52-P12D05125

Inch

Spacing: 4.95" x 4.95" x 5.26"
Material Construction: 6061 Aluminum



Built for our 52mm RockLock Quick Change System, the R52-P12D05125 provides maximum amount of flexibility. This 4 sided pyramid utilizes twelve D05125 dovetail fixtures for stock under 25mm. The orientation of the fixtures on the pyramid ensures optimal tool clearance for multiple parts. Machine up to 12 parts on this compact unit. The modular design allows for fixtures to be added or removed depending on the length of the workpiece.

R96-P12D05125

Inch

Spacing: 4.95" x 4.95" x 5.26"
Material Construction: 6061 Aluminum



Built for our 96mm RockLock Quick Change System, the R96-P12D05125 provides maximum amount of flexibility. This 4 sided pyramid utilizes twelve D05125 dovetail fixtures for stock under 25mm. The orientation of the fixtures on the pyramid ensures optimal tool clearance for multiple parts. Machine up to 12 parts on this compact unit. The modular design allows for fixtures to be added or removed depending on the length of the workpiece.

R52-P4DM25

Metric

Spacing: Ø152.4mm x 64.9mm
Material Construction: 6061 Aluminum



This compact pyramid utilizes four DM25 dovetail fixtures. The small foot print ensures no space is wasted allowing simultaneous machining of four parts. Run more parts per cycle and minimize pallet and tool changes. This versatile fixture can be mounted on trunnions, pallets, and machine tables using our 52mm RockLock Quick Change System.

R96-P4DM25

Metric

Spacing: Ø152.4mm x 64.9mm
Material Construction: 6061 Aluminum



This compact pyramid utilizes four DM25 dovetail fixtures. The small foot print ensures no space is wasted allowing simultaneous machining of four parts. Run more parts per cycle and minimize pallet and tool changes. This versatile fixture can be mounted on trunnions, pallets, and machine tables using our 96mm RockLock Quick Change System.

R52-P4D115

Inch

Size: Ø6" x 2.55"
Material Construction: 6061 Aluminum



This compact pyramid utilizes four D115 dovetail fixtures. The small foot print ensures no space is wasted allowing simultaneous machining of four parts. Run more parts per cycle and minimize pallet and tool changes. This versatile fixture can be mounted on trunnions, pallets, and machine tables using our 52mm RockLock Quick Change System.

R96-P4D115

Inch

Size: Ø6" x 2.55"
Material Construction: 6061 Aluminum



This compact pyramid utilizes four D115 dovetail fixtures. The small foot print ensures no space is wasted allowing simultaneous machining of four parts. Run more parts per cycle and minimize pallet and tool changes. This versatile fixture can be mounted on trunnions, pallets, and machine tables using our 96mm RockLock Quick Change System.

CER40



The CER40 is a quick and efficient fixture for holding round stock. The collet utilizes your existing set of standard ER40 collets allowing you to clamp different diameters of stock. The body is manufactured from hardened alloy steel.

Part Number	R52-CER40	R96-CER40
		
Size	2.95" x 2.95" x 2.67"	4.95" x 4.95" x 3.2"
Mounting	Includes PS16F	Includes PS20F
Stock Size	ER40 Collet	ER40 Collet



Dovetail Cutters

DC1750-45*
45° Indexable Dovetail Cutter, 1" shank
All of our fixtures feature a 45° dovetail.

DC1750-60*
60° Indexable Dovetail Cutter, 1" shank
Compatible with other 60° dovetail systems.

DC1750-M
45° Indexable Dovetail Cutter, 25mm shank
All of our fixtures feature a 45° dovetail.

DC1750-B
Inserts for Dovetail Cutter
Compatible with all 5th Axis dovetail cutters.



Thumb Screws

Replacement Thumbscrews:
TS10 - Used on V75100X, V75150X, DV75150X
TS12 - Used on V552, V562
TS13 - Used on DV56, DV510, V552M, V562M, and V510M
TS17 - Used on V6105M
TS58 - Used on V6105

Thumb screws are included with every vise. Fits standard 3/8" drives.

Threaded Locating Pins



Replacement Locating Pins:
LP6 - 6mm OD
LP8 - 8mm OD
LP10 - 10mm OD
LP250 - 0.250" OD
LP375 - 0.375" OD

Locating pins are included with every vise.

*Inserts sold separately.
CAD models available for download at fifthaxis.com/downloads



Machinable 6061 Aluminum Jaws

INCH

VAJ52 - 4.95" X 1.95" X 1.35" (Compatible with V552 / V562)

VAJ610 - 5.95" X 3.00" X 1.85" (Compatible with V6105)

METRIC

VAJ75X - 75mm x 45mm x 25mm (Compatible with V75100 / V75100X)

VAJ52M - 125mm x 50mm x 34mm (Compatible with V552M / V562M / V510M)

VAJ610M - 151mm x 78mm x 47mm (Compatible with V6105M)



Machinable 1018 Steel Jaws

INCH

VSJ52 - 4.95" X 1.95" X 1.35" (Compatible with V552 / V562)

VSJ610 - 4.95" X 1.95" X 1.35" (Compatible with V6105)

METRIC

VSJ75X - 75mm x 45mm x 25mm (Compatible with V75100 / V75100X)

VSJ52M - 125mm x 50mm x 34mm (Compatible with V552M / V562M / V510M)

VSJ610M - 151mm x 78mm x 47mm (Compatible with V6105M)



DJ6 Gripper Jaws

DJ6 - Compatible with standard 6" Kurt Vise.

The DJ6 gripper jaws with built-in 45° dovetails are the perfect accessory for your 6" machine vise. Jaws are heat treated and precision ground for superior repeatability and longevity. The jaws are 55 HRC, TiN coated and 25mm step depth.



Narrow Jaws

NT5-S - Compatible with V552 / V562

NT5-M - Compatible with V552M / V562M / V510M

Our 76.2mm Narrow Jaws are perfect when requiring a little bit more clearance than the standard 125.73mm jaws.

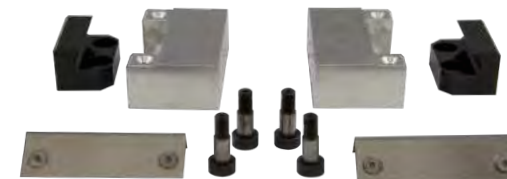

Anti-Lift Jaws

AL75A - Anti-Lift Aluminum Machinable Jaws, Starter Set. Includes steel cleats, aluminum machinable jaws, and brackets. (Compatible with V75100, V75100X, V75150X)

AL75-2A - Set of 2, Replacement Anti-Lift Machinable Aluminum Jaws. (Compatible with V75100, V75100X, V75150X)

AL75S - Anti-Lift Steel Machinable Jaws, Starter Set. Includes steel cleats, steel machinable jaws, and brackets. (Compatible with V75100, V75100X, V75150X)

AL75-2S - Set of 2, Replacement Anti-Lift Machinable Jaws, Steel. (Compatible with V75100, V75100X, V75150X)

AL52A - Anti-Lift Aluminum Machinable Jaws, Starter Set. Includes steel cleats, aluminum machinable jaws, and brackets. (Compatible with V552 / V562)

AL52MA - Anti-Lift Aluminum Machinable Jaws, Starter Set. Includes steel cleats, aluminum machinable jaws, and brackets. (Compatible with V552M / V562M / V510M)

AL52-2A - Set of 2, Replacement Anti-Lift Machinable Aluminum Jaws. (Compatible with V552 / V562 / V552M / V562M / V510M)

AL52S - Anti-Lift Steel Machinable Jaws, Starter Set. Includes steel cleats, aluminum machinable jaws, and brackets. (Compatible with V552 / V562)

AL52MS - Anti-Lift Steel Machinable Jaws, Starter Set. Includes steel cleats, aluminum machinable jaws, and brackets. (Compatible with V552M / V562M / V510M)

AL52-2S - Set of 2, Replacement Anti-Lift Machinable Jaws, Steel. (Compatible with V552 / V562 / V552M / V562M / V510M)

Our Anti-Lift Jaws use a cleat and angled soft jaw to pull the jaw in and down when torque is applied to the lead screw. This design decreases jaw lift and jaw deflection commonly seen in self-centering vises.

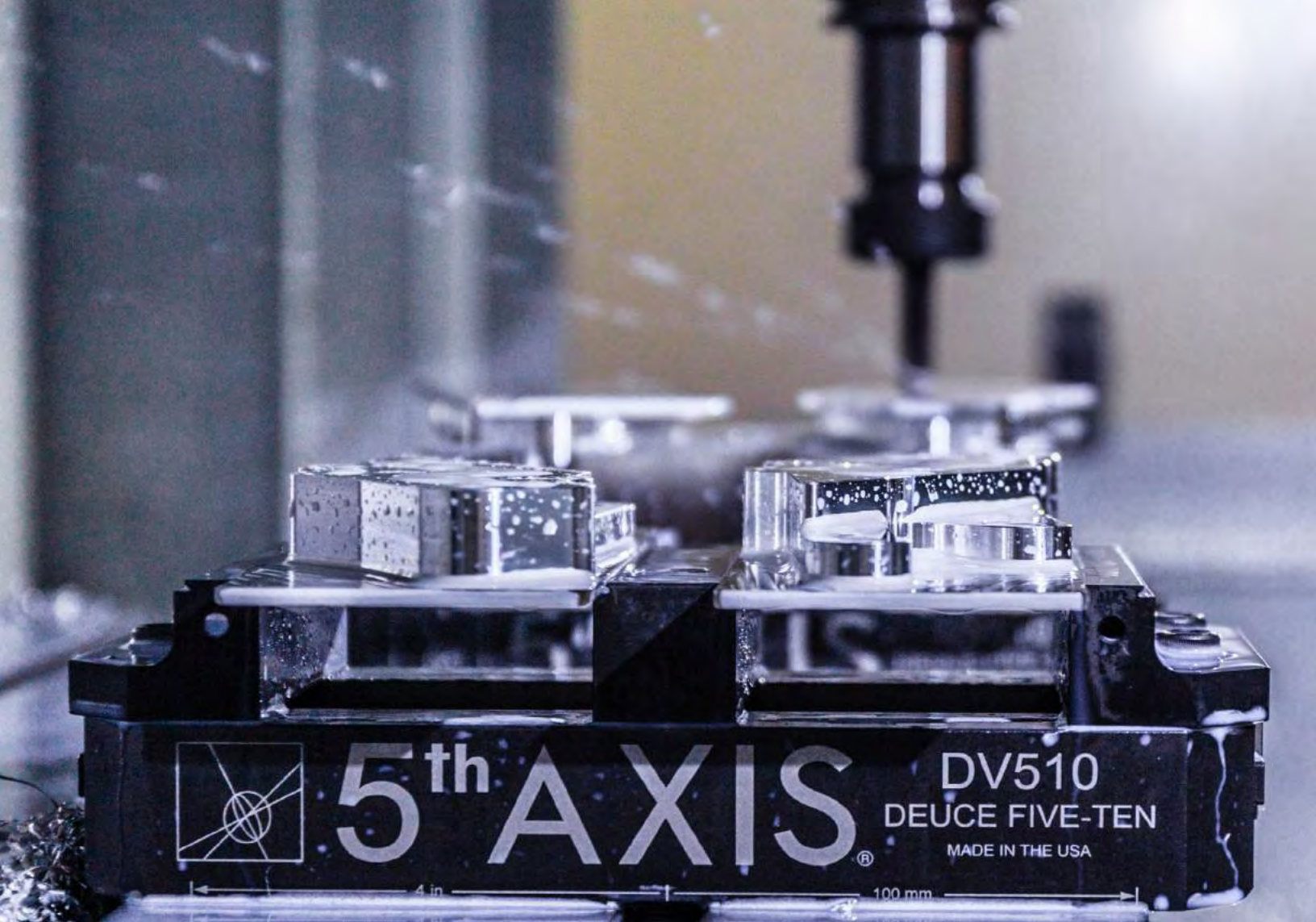

COMPLETE METALWORKING SOLUTIONS
(800) 991-4225 www.ahbinc.com
ISO Certified customerservice@ahbinc.com



Made in USA



7140 Engineer Rd.
San Diego, CA 92111
p: 858-505-0432
f: 858-505-9344
e: workholding@5thaxis.com
5thaxis.com

